



CERTIFICATE

By Authority Of
THE UNITED STATES OF AMERICA
Legally Binding Document

By the Authority Vested By Part 5 of the United States Code § 552(a) and Part 1 of the Code of Regulations § 51 the attached document has been duly INCORPORATED BY REFERENCE and shall be considered legally binding upon all citizens and residents of the United States of America. *HEED THIS NOTICE:* Criminal penalties may apply for noncompliance.



Document Name: API 5L: Specification for Line Pipe

CFR Section(s): 49 CFR 192.113

Standards Body: American Petroleum Institute



Official Incorporator:

THE EXECUTIVE DIRECTOR
OFFICE OF THE FEDERAL REGISTER
WASHINGTON, D.C.

Specification for Line Pipe

Upstream Segment

API SPECIFICATION 5L
FORTY-THIRD EDITION, MARCH 2004
EFFECTIVE DATE: OCTOBER 2004
ERRATA DECEMBER 2004



**Helping You
Get The Job
Done Right.SM**

SPECIAL NOTES

API publications necessarily address problems of a general nature. With respect to particular circumstances, local, state, and federal laws and regulations should be reviewed.

API is not undertaking to meet the duties of employers, manufacturers, or suppliers to warn and properly train and equip their employees, and others exposed, concerning health and safety risks and precautions, nor undertaking their obligations under local, state, or federal laws.

Information concerning safety and health risks and proper precautions with respect to particular materials and conditions should be obtained from the employer, the manufacturer or supplier of that material, or the material safety data sheet.

Nothing contained in any API publication is to be construed as granting any right, by implication or otherwise, for the manufacture, sale, or use of any method, apparatus, or product covered by letters patent. Neither should anything contained in the publication be construed as insuring anyone against liability for infringement of letters patent.

Generally, API standards are reviewed and revised, reaffirmed, or withdrawn at least every five years. Sometimes a one-time extension of up to two years will be added to this review cycle. This publication will no longer be in effect five years after its publication date as an operative API standard or, where an extension has been granted, upon republication. Status of the publication can be ascertained from the API Standards department telephone (202) 682-8000. A catalog of API publications, programs and services is published annually and updated biannually by API, and available through Global Engineering Documents, 15 Inverness Way East, M/S C303B, Englewood, CO 80112-5776.

This document was produced under API standardization procedures that ensure appropriate notification and participation in the developmental process and is designated as an API standard. Questions concerning the interpretation of the content of this standard or comments and questions concerning the procedures under which this standard was developed should be directed in writing to the Director of the Standards department, American Petroleum Institute, 1220 L Street, N.W., Washington, D.C. 20005. Requests for permission to reproduce or translate all or any part of the material published herein should be addressed to the Director, Business Services.

API standards are published to facilitate the broad availability of proven, sound engineering and operating practices. These standards are not intended to obviate the need for applying sound engineering judgment regarding when and where these standards should be utilized. The formulation and publication of API standards is not intended in any way to inhibit anyone from using any other practices.

Any manufacturer marking equipment or materials in conformance with the marking requirements of an API standard is solely responsible for complying with all the applicable requirements of that standard. API does not represent, warrant, or guarantee that such products do in fact conform to the applicable API standard.

All rights reserved. No part of this work may be reproduced, stored in a retrieval system, or transmitted by any means, electronic, mechanical, photocopying, recording, or otherwise, without prior written permission from the publisher. Contact the Publisher, API Publishing Services, 1220 L Street, N.W., Washington, D.C. 20005.

FOREWORD

API publications may be used by anyone desiring to do so. Every effort has been made by the Institute to assure the accuracy and reliability of the data contained in them; however, the Institute makes no representation, warranty, or guarantee in connection with this publication and hereby expressly disclaims any liability or responsibility for loss or damage resulting from its use or for the violation of any federal, state, or municipal regulation with which this publication may conflict.

Suggested revisions are invited and should be submitted to API, Standards department, 1220 L Street, NW, Washington, DC 20005.

CONTENTS

	Page	
1 SCOPE	1	
1.1 Purpose and Coverage	1	
1.2 Product Specification Level (PSL)	1	
1.3 Grades	1	
1.4 Dimensions	1	
1.5 Units	1	
2 REFERENCES	1	
3 DEFINITIONS	2	04
4 INFORMATION TO BE SUPPLIED BY THE PURCHASER	3	
5 PROCESS OF MANUFACTURE AND MATERIAL	6	
5.1 Process of Manufacture	6	
5.2 Cold Expansion	8	
5.3 Material	8	
5.4 Heat Treatment	8	04
5.5 Skelp End Welds in Helical Seam Pipe	8	
5.6 Traceability	8	
6 MATERIAL REQUIREMENTS	8	
6.1 Chemical Properties	8	
6.2 Mechanical Properties	9	04
7 DIMENSIONS, WEIGHTS, LENGTHS, DEFECTS, AND END FINISHES	10	
7.1 Specified Dimensions	10	
7.2 Diameter	10	
7.3 Wall Thickness	11	
7.4 Weight	11	
7.5 Length	11	
7.6 Straightness	12	
7.7 Joints	12	
7.8 Workmanship and Defects	12	04
7.9 Pipe Ends	14	
8 COUPLINGS (PSL 1 ONLY)	15	
8.1 Material	15	
8.2 Tensile Tests	15	
8.3 Dimensions	15	
8.4 Inspection	15	
9 INSPECTION AND TESTING	15	
9.1 Test Equipment	15	
9.2 Testing of Chemical Composition	15	
9.3 Testing of Mechanical Properties	15	04
9.4 Hydrostatic Tests	17	
9.5 Dimensional Testing	18	
9.6 Surface Inspection	18	

	Page		
9.7	Visual Inspection	18	04
9.8	Nondestructive Inspection	18	
9.9	Disposition of Pipe Containing Defects	22	04
9.10	Test Methods	22	
9.11	Invalidation of Tests	23	04
9.12	Retests	23	
9.13	Reprocessing	24	
10	MARKING	24	
10.1	General	24	
10.2	Location of Markings	25	
10.3	Sequence of Markings	25	
10.4	Bundle Identification	26	
10.5	Length	26	
10.6	Couplings	26	
10.7	Die Stamping	26	
10.8	Thread Identification	27	
10.9	Thread Certification	27	
10.10	Pipe Processor Markings	27	
11	COATING AND PROTECTION	27	
11.1	Coatings	27	
11.2	Thread Protectors	27	
12	DOCUMENTS	27	
12.1	Certification	27	
12.2	Retention of Records	28	
13	PIPE LOADING	28	
APPENDIX A	SPECIFICATION FOR WELDED JOINTERS (NORMATIVE)	79	
APPENDIX B	REPAIR OF DEFECTS BY WELDING (NORMATIVE)	81	04
APPENDIX C	REPAIR WELDING PROCEDURE (NORMATIVE)	83	
APPENDIX D	ELONGATION TABLE (NORMATIVE)	89	
APPENDIX E	DIMENSIONS, WEIGHTS, AND TEST PRESSURES —SI UNITS (NORMATIVE)	93	
APPENDIX F	SUPPLEMENTARY REQUIREMENTS (NORMATIVE)	121	04
APPENDIX G	GUIDED-BEND TEST JIG DIMENSIONS (NORMATIVE)	131	
APPENDIX H	PURCHASER INSPECTION (NORMATIVE)	143	
APPENDIX I	MARKING INSTRUCTIONS FOR API LICENSEES (NORMATIVE)	145	
APPENDIX J	SUMMARY OF DIFFERENCES BETWEEN PSL 1 AND PSL 2 (INFORMATIVE)	149	04
APPENDIX K	END LOAD COMPENSATION FOR HYDROSTATIC TEST PRESSURES IN EXCESS OF 90% OF SPECIFIED MINIMUM YIELD STRENGTH (NORMATIVE)	151	
APPENDIX M	CONVERSION PROCEDURES	153	

Figures

1	Belled End for Bell and Spigot Joint	28	
2	Line Pipe and Couplings	28	
3	Orientation of Tensile Test Specimens	29	
4	Tensile Test Specimens	30	
5	Flattening Tests	31	04
6	API Standard penetrometer	31	
7	Examples of Maximum Distribution Patterns of Indicated Circular Slag-inclusion and Gas-pocket-type Discontinuities	32	
8	Examples of Maximum Distribution Patterns of Indicated Elongated Slag-inclusion-type Discontinuities	33	
9	Guided-bend Test Specimen	33	
10	Jig for Guided-bend Test	34	04
B-1	Resultant Cavity for Undercut Repair (PSL 2 Only)	82	
C-1	Transverse Tensile Test Specimen	85	
C-2	Guided-bend Test Specimen	85	
C-3	Jig for Guided-bend Test	86	
C-4	Nick-break Test Specimen	87	
F-1	Impact Test Specimen Tapered End Allowance	126	04
F-2	Charpy V-notch and Drop-weight Tear Test Specimen Locations	127	

Tables

1	Process of Manufacture and Product Specification Level (PSL)	35	
2A	PSL 1 Chemical Requirements for heat and Product Analyses by Percentage of Weight	36	
2B	PSL 2 Chemical Requirements for Heat and Product Analyses by Percentage of Weight	36	04
3A	Tensile Requirements for PSL 1	37	
3B	Tensile Requirements for PSL 2	37	
4	Standard-wall Threaded line Pipe Dimensions, Weights, and Test Pressures (U.S. Customary and SI Units)	38	
5	Heavy-wall Threaded Line Pipe Dimensions, Weights, and Test Pressures (U.S. Customary and SI Units)	39	
6A	Plain-end Line Pipe Dimensions, Weights per Unit Length, and Test Pressures for Sizes 0.405 through 1.900 (U.S. Customary Units)	40	
6B	Plain-end Line Pipe Dimensions, Weights per Unit Length, and Test Pressures for Sizes 2 ³ / ₈ through 5 ⁹ / ₁₆ (U.S. Customary Units)	41	
6C	Plain-end Line Pipe Dimensions, Weights per Unit Length, and Test Pressures for Sizes 6 ⁵ / ₈ through 80 (U.S. Customary Units)	44	
7	Tolerances for Diameter of Pipe Body	68	
8	Tolerance for Diameter at Pipe Ends	68	
9	Tolerances for Wall Thickness	68	
10	Tolerances for Weight	69	
11	Tolerances on Lengths	69	
12	Coupling Dimensions, Weights, and Tolerances	70	
13	Maximum Inspection Lot Size for Tensile Testing	71	
14	Relationship between Pipe Dimensions and Required Charpy Specimens	71	04
14A	Relationship between Pipe Dimensions and Transverse Tensile Specimens	72	
15	ASTM Hole-type IQI for Fluoroscopic Inspection	72	
16	ASTM Hole-type IQI for Radiographic Inspection	73	
17	ISO Wire-type IQI for Fluoroscopic Inspection	73	
18	ISO Wire-type IQI for Radiographic Inspection	73	

	Page	
19	ASTM Wire-type IQI for Fluoroscopic Inspection	74
20	ASTM Wire-type IQI for Radiographic Inspection	74
21	Elongated Slag-inclusion-type Discontinuities	74
22	Circular Slag-inclusion-type and Gas-pocket-type Discontinuities.	75
23	Acceptance Limits.	75
24	Pipe Weld Seam Nondestructive Inspection Methods	75
25	Pipe Body Nondestructive Inspection Methods—Seamless	76
26	Reference Indicators	76
27	Retention of Records.	77
C-1	Guided-bend Test Jig Dimensions	87
D-1	Elongation Table (U.S. Customary Units)	89
D-2	Elongation Table (SI Units).	91
E-6A	Plain-end Line Pipe Dimensions, Weights per Unit Length, and Test Pressures for Sizes 0.405 Through 1.900 (SI Units)	93
E-6B	Plain-end Line Pipe Dimensions, Weights per Unit Length, and test Pressures for Sizes 2 ³ / ₈ through 5 ⁹ / ₁₆ (SI Units)	94
E-6C	Plain-end Line Pipe Dimensions, Weights per Unit Length, and Test Pressures for Sizes 6 ⁵ / ₈ through 80 (SI Units).	97
F-1	Minimum Wall Thickness to Obtain Transverse Charpy V-notch Test Specimens	127
F-2	Dimensions, Weights per Unit Length, and Test Pressures for TFL Pipe	128
F-3	Minimum All-heat Average Absorbed Energy Requirements for Stress Fractor <i>f</i> of 0.72	128
G-1	Guided-bend Test Jig Dimensions	131

| 04

| 04

| 04

Specification for Line Pipe

1 Scope

1.1 PURPOSE AND COVERAGE

The purpose of this specification is to provide standards for pipe suitable for use in conveying gas, water, and oil in both the oil and natural gas industries.

This specification covers seamless and welded steel line pipe. It includes plain-end, threaded-end, and belled-end pipe, as well as through-the-flowline (TFL) pipe and pipe with ends prepared for use with special couplings.

Although the plain-end line pipe meeting this specification is primarily intended for field makeup by circumferential welding, the manufacturer will not assume responsibility for field welding.

1.2 PRODUCT SPECIFICATION LEVEL (PSL)

This specification establishes requirements for two product specification levels (PSL 1 and PSL 2). These two PSL designations define different levels of standard technical requirements. PSL 2 has mandatory requirements for carbon equivalent, notch toughness, maximum yield strength, and maximum tensile strength. These and other differences are summarized in Appendix J.

Requirements that apply to only PSL 1 or only PSL 2 are so designated. Requirements that are not designated to a specific PSL apply to both PSL 1 and PSL 2.

The purchaser may add requirements to purchase orders for either PSL 1 or PSL 2, as provided by the supplementary requirements (Appendix F) and other options (4.2 and 4.3).

1.3 GRADES

The grades (see the note) covered by this specification are the standard Grades A25, A, B, X42, X46, X52, X56, X60, X65, X70 and X80; and any intermediate grades (grades that are higher than X42, intermediate to two sequential standard grades, and agreed upon by the purchaser and manufacturer).

PSL 1 pipe can be supplied in Grades A25 through X70.

PSL 2 pipe can be supplied in Grades B through X80.

Class II (CI II) steel is rephosphorized and probably has better threading properties than Class I (CI I). Because Class II (CI II) has higher phosphorus content than Class I (CI I), it may be somewhat more difficult to bend.

Pipe manufactured as Grade X60 or higher shall not be substituted for pipe ordered as Grade X52 or lower without purchaser approval.

Note: The grade designations are dimensionless. Grades A and B do not include reference to the specified minimum yield strength; however, other grade designations are composed of the letter A or X, followed by the first two digits of the specified minimum yield strength in U.S. Customary units.

1.4 DIMENSIONS

The sizes used herein are dimensionless designations, which are derived from the specified outside diameter as measured in U.S. Customary units, and provide a convenient method of referencing pipe size within the text and tables (but not for order descriptions). Pipe sizes 23/8 and larger are expressed as integers and fractions; pipe sizes smaller than 23/8 are expressed to three decimal places. These sizes replace the "size designation" and the "nominal size designation" used in the previous edition of this specification. Users of this specification who are accustomed to specifying nominal sizes rather than OD sizes are advised to familiarize themselves with these new size designations used in this specification, especially the usage in Tables 4, 5, and 6A.

PSL 1 pipe can be supplied in sizes ranging from 0.405 through 80.

PSL 2 pipe can be supplied in sizes ranging from 4^{1/2} through 80.

Dimensional requirements on threads and thread gages, stipulations on gaging practice, gage specifications and certification, as well as instruments and methods for inspection of threads are given in API Standard 5B and are applicable to threaded products covered by this specification.

1.5 UNITS

U.S. Customary units are used in this specification; SI (metric) units are shown in parentheses in the text and in many tables. The values stated in either U.S. Customary units or SI units are to be regarded separately as standard. The values stated are not necessarily exact equivalents; therefore, each system is to be used independently of the other, without combining values for any specific order item.

See Appendix M for specific information about rounding procedures and conversion factors.

2 References

2.1 This specification includes by reference, either in total or in part, the latest editions of the following API and industry standards:

API	
RP 5A3	<i>Thread Compounds for Casing, Tubing, and Line Pipe</i>
Spec 5B	<i>Specification for Threading, Gauging, and Thread Inspection of Casing, Tubing, and Line Pipe Threads</i>
RP 5L1	<i>Recommended Practice for Railroad Transportation of Line Pipe</i>
RP 5L3	<i>Recommended Practice for Conducting Drop-Weight Tear Tests on Line Pipe</i>

RP 5LW	<i>Recommended Practice for Transportation of Line Pipe on Barges and Marine Vessels</i>
Std 1104	<i>Welding of Pipelines and Related Facilities</i>
AAR ¹	
Section 1	<i>General Rules Governing the Loading of Commodities on Open Top Cars</i>
Section 2	<i>Rules Governing the Loading of Steel Products Including Pipe on Open Top Cars</i>
ASME ²	
	<i>ASME Boiler and Pressure Vessel Code, Section IX, Welding & Brazing Qualifications</i>
	<i>ASME Code for Pressure Piping B31.8, Gas Transmission and Distribution Piping Systems</i>
ASNT ³	
04 SNT-TC-1A	<i>Recommended Practice No. SNT-TC-1A</i>
ASTM ⁴	
A 370	<i>Methods and Definitions for Mechanical Testing of Steel Products</i>
A 751	<i>Test Methods, Practices, and Definitions for Chemical Analysis of Steel Products</i>
E 4	<i>Practices for Force Verification of Testing Machines</i>
E 8	<i>Test Methods for Tension Testing of Metallic Materials</i>
E 29	<i>Practice for Using Significant Digits in Test Data to Determine Conformance with Specifications</i>
E 83	<i>Practice for Verification and Classification of Extensometers</i>
E 94	<i>Standard Guide for Radiographic Examination</i>
E 165	<i>Standard Test Method for Liquid Penetrant Examination</i>
E 213	<i>Standard Practice for Ultrasonic Examination of Metal Pipe and Tubing</i>
E 273	<i>Standard Practice for Ultrasonic Examination of the Welded Zone of Welded Pipe and Tubing</i>

¹American Association of Railroads, Operations and Maintenance Department, Mechanical Division, 50 F Street, N.W. Washington, D.C. 20001.

²ASME International, 3 Park Avenue, New York, New York 10016-5990.

³American Society for Nondestructive Testing, Inc., 1711 Arlington Lane, P.O. Box 28518, Columbus, Ohio 43228-0518.

⁴American Society for Testing and Materials, 100 Barr Harbor Drive, West Conshohocken, Pennsylvania 19428-2959.

E 309	<i>Standard Practice for Eddy-Current Examination of Steel Tubular Products Using Magnetic Saturation</i>
E 570	<i>Standard Practice for Flux Leakage Examination of Ferromagnetic Steel Tubular Products</i>
E 709	<i>Standard Guide for Magnetic Particle Examination</i>

2.2 Requirements of standards included by reference in this specification are essential to the safety and interchangeability of the equipment produced.

2.3 Standards referenced in this specification may be replaced by other international or national standards that can be shown to meet the requirements of the referenced standard. Manufacturers who use other standards in lieu of standards referenced herein are responsible for documenting the equivalency of the standards.

3 Definitions

For the purposes of this specification, the following definitions apply:

3.1 calibration: The adjustment of instruments to a known basic reference, often traceable to the National Institute of Standards and Technology or an equivalent organization.

3.2 carload: The quantity of pipe loaded on a rail car for shipment from the pipe-making facilities.

3.3 cold expanded pipe: Pipe that, while at ambient mill temperature, has received a permanent increase in outside diameter or circumference of at least 0.3%, throughout its length, by internal hydrostatic pressure in closed dies or by an internal expanding mechanical device.

3.4 defect: An imperfection of sufficient magnitude to warrant rejection of the product based on the stipulations of this specification.

3.5 heat: The metal produced by a single cycle of a batch melting process.

3.6 heat analysis: The chemical analysis representative of a heat as reported by the metal producer.

3.7 imperfection: A discontinuity or irregularity in the product detected by methods outlined in this specification.

3.8 inspection lot: A definite quantity of product manufactured under conditions that are considered uniform for the attribute to be inspected.

3.9 manufacturer: A firm, company, or corporation responsible for marking the product to warrant that it conforms to this specification. The manufacturer may be, as applicable, a pipe mill or processor; a maker of couplings; or

a threader. The manufacturer is responsible for compliance with all of the applicable provisions of this specification.

3.10 may: Used as a verb to indicate that a provision is optional.

3.11 pipe mill: A firm, company, or corporation that operates pipe-making facilities.

3.12 processor: A firm, company, or corporation that operates facilities capable of heat treating pipe made by a pipe mill.

3.13 product analysis: A chemical analysis of the pipe, plate, or skelp.

3.14 PSL: Abbreviation for product specification level.

3.15 shall: Used to indicate that a provision is mandatory.

3.16 should: Used to indicate that a provision is not mandatory but is recommended as good practice.

3.17 special processes: Final operations performed during pipe manufacturing that affect attribute compliance required in this specification (except chemistry and dimensions). The applicable special processes are as follows:

Manufacturing Condition	Special Processes
a. Seamless:	
1. As-rolled (nonexpanded)	Final reheating and hot sizing or stretch reduction. Cold finishing, if applied, and repair welding. Nondestructive inspection
2. As-rolled (expanded)	Cold expansion, nondestructive inspection, and repair welding.
3. Heat treated	Heat treatment, nondestructive inspection, and repair welding.
b. Welded without filler metal:	
1. As-rolled (nonexpanded)	Seam welding, nondestructive inspection and sizing. If applicable, seam heat treatment and repair welding.
2. As-rolled (cold expanded)	Seam welding, cold expansion, and nondestructive inspection. If applicable, seam heat treatment, and repair welding.
3. Heat treated	Seam welding, full body heat treatment, and nondestructive inspection. If applicable, repair welding.
c. Welded with filler metal:	
1. As-rolled (nonexpanded)	Pipe forming, seam welding, nondestructive inspection, and repair welding.
2. As-rolled (expanded)	Seam welding, expansion, nondestructive inspection, and repair welding.
3. Heat treated	Seam welding, nondestructive inspection, repair welding, and full body heat treatment.

04

04

3.18 standardization: The adjustment of a nondestructive inspection instrument to an arbitrary reference value.

3.19 undercut: A groove melted into the parent metal adjacent to the weld toe and left unfilled by the deposited weld metal.

4 Information to be Supplied by the Purchaser (See Note 1)

4.1 In placing orders for line pipe to be manufactured in accordance with API Spec 5L, the purchaser should specify the following on the purchase order:

4.2 The purchaser should also state on the purchase order his requirements concerning the following stipulations, which are optional with the purchaser:

Information	Reference
Certificate of compliance, general	Paragraph 12.1
Certificate of compliance, with test results	Paragraph 12.1 and SR 15
Cold expanded or nonexpanded pipe	Paragraph 5.2
High carbon equivalent pipe	Paragraph 6.1.3.2
Optional fracture toughness: test type, temperature, and Charpy energy value	Paragraph 6.2.5 and SR5, SR6, and SR19
Acceptance and maximum percent of jointers	Paragraph 7.7
Jointers for threaded pipe	Paragraph 7.7
Thread compound	Paragraph 7.9.2
Reduced negative tolerance for wall thickness	Tables 9 and 10
Power-tight makeup	Paragraph 7.9.2
Specific edition of Spec 5L for pipe and couplings	Paragraph 7.9.2
Alternative bevel or end preparation, plain-end pipe	Paragraph 7.9.3

04

04

	Information	Reference
	Alternative minimum hydrostatic test pressure	Paragraph 9.4.3
	Hydrostatic test pressure, maximum	Paragraph 9.4.3
04	Special inspection of electric welded seams	Paragraph 9.8.3 and SR17
	Alternative inspection of laser welded seams	Paragraph 9.8.3 and SR17
	Type of penetrometer for radiological inspection	Paragraph 9.8.4.2
	Bare pipe; temporary and special coatings	Paragraph 11.1
	Special nondestructive inspection for laminations	Paragraph 7.8.10
04	Demonstration of capability of magnetic particle inspection method	Paragraph 9.8.6.3
	Through-the-Flowline (TFL) Pipe	SR7
04	Length tolerance and jointer allowance for TFL pipe	Paragraph SR7.3
	Marking Requirements	
	Alternative length units	Paragraph 10.5 and 1.5
	Additional markings for compatible standards	Paragraph 10.1.3 and 1.1.3
	Marking location and sequence for welded pipe, size 16 and larger	Paragraph 1.2c and 1.2.3
	Die stamping of pipe or plate	Paragraphs 10.7 and 1.7
	Method of welding jointers	Paragraph A.1
04	Purchaser inspection	Appendix H
	Inspection location	Paragraph H.2
	Monogram marking (see Note 2)	Paragraph I.1

4.3 The following stipulations are subject to agreement between the purchaser and the manufacturer:

	Information	Reference
	Alternative heat treatment for electric weld seams	Paragraph 5.1.3.3
	Alternative heat treatment for laser weld seams	Paragraph 5.1.3.4
	Quenching and tempering of Grade B pipe	Paragraph 5.4
	Skelp end welds at pipe ends	Paragraph 5.5
	Chemical composition	Paragraph 6.1.1
	Intermediate grade	Paragraphs 6.1.1 and 6.2.1
	Carbon equivalent limit (PSL 2)	
	Grade X80	Paragraph 6.1.3.2
	Seamless with wall thickness > 0.800 in (20.3 mm)	Paragraph 6.1.3.2
	High carbon equivalent pipe	Paragraph 6.1.3.2
	Charpy specimen size for optional fracture toughness	Paragraph SR5.3
	Type of notch for drop weight tear test specimens	SR6.3
	Internal diameter tolerance	Paragraph 7.2
	Intermediate diameter	Paragraph 7.1
	Intermediate wall thickness	Paragraph 7.1
	Skelp end welds at jointer welds	Paragraph 7.7
	Hydrostatic test for threaded and coupled pipe	Paragraph 9.4.1
	Higher hydrostatic test pressure	Paragraph 9.4.3
	End load compensation for hydrotest producing stress > 90% SMYS	Paragraph 9.4.3 and Appendix K
	Supplementary hydrostatic test	Paragraph 9.4.4
	Diameter tolerance for nonstandard hydrotest	Table 7
04	Alternative penetrometer for radiological inspection	Paragraph 9.8.4.2
	Alternative reinspection method for gas-metal-arc welds	Paragraph 9.8.5.4
	Technique for nondestructive inspection of electric welds and laser welds	Paragraph SR17.2
	Length tolerances applied to carloads	Table 11
	Nonstandard length and length tolerances	Paragraph 7.5
	Welded couplings	Paragraph 8.1
	NDT for repair of pipe body by welding	Paragraph B.1.1
04	Repair of weld seams of electric welded pipe	Paragraphs 9.8.5.6 and B.1.2
	Repair of weld seams of laser welded pipe	Paragraphs 9.8.5.6 and B.1.2
	Repair of heat-treated pipe by welding	Paragraph B.1.3

Information	Reference
Reprocessing by heat-treatment	Paragraphs 9.13 and SR5.5
Disposition of product rejected by purchaser	Paragraph H.4
Marking requirements	
Marking of couplings without die stamping	Paragraphs 10.1.2 and I.1.2
Marking on interior instead of exterior (welded pipe < size 16, and seamless pipe)	Paragraphs 10.2b and I.2.2
Color code marking for grade	Paragraphs 10.3.5 and I.3.5; SR3
Nonstandard units of length	Paragraphs 10.5 and I.5
Location for length markings	Paragraphs 10.5a and I.5a
Use of cold die stamping	Paragraphs 10.7 and I.7

Note:

1. Nothing in this specification should be interpreted as indicating a preference by the committee for any material or process or as indicating equality between the various materials or processes. In the selection of materials and processes, the purchaser has to be guided by experience and by the service for which the pipe is intended.

2. Users of this specification should note that there is no longer a requirement for marking a product with the API monogram. The American Petroleum Institute continues to license use of the monogram on products covered by this specification, but it is administered by the staff of the Institute separately from the specification. The policy describing use of the monogram is contained in Appendix I. No other use of the monogram is permitted. Licensees mark products in accordance with Appendix I or Section 10, and nonlicensees mark products in accordance with Section 10.

5 Process of Manufacture and Material

5.1 PROCESS OF MANUFACTURE

Pipe furnished to this specification shall be either seamless or welded as defined in 5.1.1, 5.1.2, and 5.1.3 and shall be limited to the product specification levels, grades, types of pipe, and size limitations specified in Table 1.

5.1.1 Seamless Process

The seamless process is a process of hot working steel to form a tubular product without a welded seam. If necessary, the hot worked tubular product may be subsequently cold finished to produce the desired shape, dimensions, and properties.

5.1.2 Welding Processes

5.1.2.1 Without Filler Metal

5.1.2.1.1 Continuous Welding

Continuous welding is a process of forming a seam by heating the skelp in a furnace and mechanically pressing the formed edges together wherein successive coils of skelp have been joined together to provide a continuous flow of steel for the welding mill. (This process is a type of butt-welding.)

5.1.2.1.2 Electric Welding

Electric welding is a process of forming a seam by electric-resistance or electric-induction welding wherein the edges to be welded are mechanically pressed together and the heat for welding is generated by the resistance to flow of the electric current.

5.1.2.1.3 Laser Welding

Laser welding is a welding process that uses a laser beam and a keyholing technique to produce melting and coalescence of the edges to be welded. The edges may be preheated. Shielding is obtained entirely from an externally supplied gas or gas mixture.

5.1.2.2 With Filler Metal

5.1.2.2.1 Submerged-Arc Welding

Submerged-arc welding is a welding process that produces coalescence of metals by heating them with an arc or arcs between a bare metal consumable electrode or electrodes and the work. The arc and molten metal are shielded by a blanket of granular, fusible material on the work. Pressure is not used, and part or all of the filler metal is obtained from the electrodes.

5.1.2.2.2 Gas Metal-Arc Welding

Gas metal-arc welding is a welding process that produces coalescence of metals by heating them with an arc or arcs between a continuous consumable electrode and the work. Shielding is obtained entirely from an externally supplied gas or gas mixture. Pressure is not used, and the filler metal is obtained from the electrode.

5.1.3 Types of Pipe

5.1.3.1 Seamless Pipe

Seamless pipe is produced by the seamless process defined in 5.1.1.

5.1.3.2 Continuous Welded Pipe

Continuous welded pipe is defined as pipe that has one longitudinal seam produced by the continuous welding process defined in 5.1.2.1.1. (This is a type of butt-welded pipe.)

5.1.3.3 Electric Welded Pipe

Electric welded pipe is defined as pipe that has one longitudinal seam produced by the electric welding process defined in 5.1.2.1.2.

5.1.3.3.1 PSL 1 Electric Welded Pipe

For grades higher than X42, the weld seam and the entire heat affected zone shall be heat treated so as to simulate a normalizing heat treatment (see note), except that by agreement between the purchaser and the manufacturer alternative heat treatments or combinations of heat treatment and chemical composition may be substituted. Where such substitutions are made, the manufacturer shall demonstrate the effectiveness of the method selected using a procedure that is mutually agreed upon. This procedure may include, but is not necessarily limited to, hardness testing, microstructural evaluation, or mechanical testing. For grades X42 and lower, the weld seam shall be similarly heat treated, or the pipe shall be processed in such a manner that no untempered martensite remains.

Note: During the manufacture of electric welded pipe, the product is in motion through the surrounding air. Normalizing is usually defined with "cooling in still air;" hence the phrase "to simulate a normalizing heat treatment" is used here.

5.1.3.3.2 PSL 2 Electric Welded Pipe

Electric welding shall be performed with a minimum welder frequency of 100 kHz.

For all grades, the weld seam and the entire heat affected zone shall be heat treated so as to simulate a normalizing heat treatment (see note in 5.1.3.3.1), except that by agreement between the purchaser and the manufacturer alternative heat treatments or combinations of heat treatment and chemical

composition may be substituted. Where such substitutions are made, the manufacturer shall demonstrate the effectiveness of the method selected using a procedure that is mutually agreed upon. This procedure may include, but is not necessarily limited to, hardness testing, microstructural evaluation, or mechanical testing.

5.1.3.4 Laser Welded Pipe

Laser welded pipe is defined as pipe that has one longitudinal seam produced by the laser welding process defined in 5.1.2.1.3.

The weld seam and the entire heat affected zone of laser welded pipe shall be heat treated so as to simulate a normalizing heat treatment, except that by agreement between the purchaser and manufacturer, an alternative process may be substituted. Where such substitution is made, the manufacturer shall demonstrate the effectiveness of the method selected, using a procedure that is mutually agreed upon. This procedure may include, but is not necessarily limited to, hardness testing, microstructural evaluation, or mechanical testing.

Note: During the manufacture of laser welded pipe, the product is in motion through the surrounding air. Normalizing is usually defined with "cooling in still air;" hence the phrase "to simulate a normalizing heat treatment" is used here.

5.1.3.5 Longitudinal Seam Submerged-Arc Welded Pipe

Longitudinal seam submerged-arc welded pipe is defined as pipe that has one longitudinal seam produced by the automatic submerged-arc welding process defined in 5.1.2.2.1. At least one pass shall be on the inside and at least one pass shall be on the outside. (This type of pipe is also known as submerged-arc welded pipe.)

5.1.3.6 Gas Metal-Arc Welded Pipe

Gas metal-arc welded pipe is defined as pipe that has one longitudinal seam produced by the continuous gas metal-arc welding process defined in 5.1.2.2.2. At least one pass shall be on the inside and at least one pass shall be on the outside.

5.1.3.7 Combination Gas Metal-Arc and Submerged-Arc Welded Pipe

Combination gas metal-arc and submerged-arc welded pipe is defined as pipe that has one longitudinal seam produced by a combination of the welding processes defined in 5.1.2.2.1 and 5.1.2.2.2. The gas metal-arc welding process shall be continuous and first, and followed by the automatic submerged-arc welding process with at least one pass on the inside and at least one pass on the outside.

5.1.3.8 Double Seam Submerged-Arc Welded Pipe

Double seam submerged-arc welded pipe is defined as pipe that has two longitudinal seams produced by the automatic submerged-arc welding process defined in 5.1.2.2.1. The seams shall be approximately 180° apart. For each seam, at least one pass shall be on the inside and at least one pass shall be on the outside. All weld tests shall be performed after forming and welding.

5.1.3.9 Double Seam Gas Metal-Arc Welded Pipe

Double seam gas metal-arc welded pipe is defined as pipe that has two longitudinal seams produced by the gas metal-arc welding process defined in 5.1.2.2.2. The seams shall be approximately 180° apart. For each seam, at least one pass shall be on the inside and at least one pass shall be on the outside. All weld tests shall be performed after forming and welding.

5.1.3.10 Double Seam Combination Gas Metal-Arc and Submerged-Arc Welded Pipe

Double seam combination gas metal-arc and submerged-arc welded pipe is defined as pipe that has two longitudinal seams produced by a combination of the welding processes defined in 5.1.2.2.1 and 5.1.2.2.2. The seams shall be approximately 180° apart. For each seam, the gas metal-arc welding shall be continuous and first, and followed by the automatic submerged-arc welding process with at least one pass on the inside and at least one pass on the outside. All weld tests shall be performed after forming and welding.

5.1.3.11 Helical Seam Submerged-Arc Welded Pipe

Helical seam submerged-arc welded pipe is defined as pipe that has one helical seam produced by the automatic submerged-arc welding process defined in 5.1.2.2.1. At least one pass shall be on the inside and at least one pass shall be on the outside. (This type of pipe is also known as spiral weld pipe.)

5.1.4 Types of Seam Welds

5.1.4.1 Electric Weld

An electric weld is a longitudinal seam weld produced by the electric welding process defined in 5.1.2.1.2.

5.1.4.2 Laser Weld

A laser weld is a longitudinal seam weld produced by the laser welding process defined in 5.1.2.1.3.

5.1.4.3 Submerged-arc Weld

A submerged-arc weld is a longitudinal or helical seam weld produced by the submerged-arc welding process defined in 5.1.2.2.1.

5.1.4.4 Gas Metal-arc Weld

A gas metal-arc weld is a longitudinal seam weld produced in whole or in part by the continuous gas metal-arc welding process defined in 5.1.2.2.2.

5.1.4.5 Skelp End Weld

A skelp end weld is a seam weld that joins plate or skelp ends together in helical seam pipe.

5.1.4.6 Jointer Weld

A jointer weld is a circumferential seam weld that joins two pieces of pipe together.

5.1.4.7 Tack Weld

A tack weld is a seam weld used to align the abutting edges until the final seam welds are produced. Tack welds shall be made by the following: (a) manual or semi-automatic submerged-arc welding, (b) electric welding, (c) gas metal-arc welding, (d) flux cored arc welding, or (e) shielded metal-arc welding using low hydrogen electrodes. Tack welds shall be removed by machining or remelting during subsequent welding of the seam.

5.2 COLD EXPANSION

Pipe furnished to this specification, except continuous welded, shall be either nonexpanded or cold expanded (see 3.3) at the option of the manufacturer, unless otherwise specified on the purchase order. Suitable provision shall be incorporated to protect the weld from contact with the internal expanding mechanical device during mechanical expansion.

5.3 MATERIAL

5.3.1 Plate and Skelp for Helical Seam Pipe

The width of plate or skelp used to manufacture helical seam pipe shall not be less than 0.8 or more than 3.0 times the outside diameter of the pipe.

5.3.2 Repairs by Welding of Plate or Skelp (PSL 2 Only)

The plate or skelp used for PSL 2 pipe shall not contain any repair welds.

5.4 HEAT TREATMENT

The heat treating process shall be performed in accordance with a documented procedure. Pipe furnished to this specification may be as-rolled, normalized, normalized and

tempered, subcritically stress relieved, or subcritically age hardened; and X Grades may be quenched and tempered. Grade B pipe that is quenched and tempered shall be seamless and shall be by agreement between the purchaser and the manufacturer. See Section 10 for applicable marking requirements.

5.5 SKELP END WELDS IN HELICAL SEAM PIPE

Junctions of skelp end welds and helical seam welds in finished pipe shall be permitted only at distances greater than 12 in. (305 mm) from the pipe ends. By agreement between the purchaser and the manufacturer, skelp end welds shall be permitted at the pipe ends, provided there is a circumferential separation of at least 6 in. (152 mm) between the skelp end weld and the helical seam weld at the applicable pipe ends. Skelp end welds in finished pipe shall be properly prepared for welding and shall be made by automatic submerged-arc welding, automatic gas metal-arc welding, or a combination of both processes.

5.6 TRACEABILITY

5.6.1 PSL 1 Traceability Requirements

The manufacturer shall establish and follow procedures for maintaining heat and/or lot identity until all required heat and/or lot tests are performed and conformance with specification requirements is shown.

5.6.2 PSL 2 Heat and Lot Traceability Requirements

The manufacturer shall comply with SR 15.2.

6 Material Requirements

6.1 CHEMICAL PROPERTIES

6.1.1 Chemical Composition

The composition of steel used for the manufacture of pipe furnished to this specification shall conform to the chemical requirements given in Table 2A (for PSL 1) or Table 2B (for PSL 2). The composition of intermediate grades (higher than X42) shall conform to the chemical requirements of the next higher standard grade. For Grades X42 and higher, by agreement between the purchaser and the manufacturer, elements other those listed in Tables 2A and 2B (which include columbium [niobium], vanadium, and titanium via the notes to the tables) may be used; however, care should be exercised in determining the alloying content for any given size and wall thickness of pipe, because the addition of such otherwise desirable elements may affect the weldability of the pipe.

6.1.2 Elements Analyzed

As a minimum, each required analysis shall include the following elements:

- Carbon, manganese, phosphorus, sulfur, chromium, columbium [niobium], copper, molybdenum, nickel, silicon, titanium, and vanadium.
- Boron. (But if the heat analysis indicates a boron content less than 0.001%, then no boron determination is required for the product analysis.)
- Any other alloying element added during steelmaking for a purpose other than deoxidation.

6.1.3 Carbon Equivalent (PSL 2 only)

6.1.3.1 Calculation of Carbon Equivalent

For PSL 2 pipe, carbon equivalent (CE) calculations shall be based on the product analyses and shall be calculated as follows. All carbon equivalent results shall be reported:

- When the carbon content is less than or equal to 0.12%, the carbon equivalent shall be calculated using the following formula for $CE(Pcm)$ [see Note 1]:

$$CE(Pcm) = C + \frac{Si}{30} + \frac{Mn}{20} + \frac{Cu}{20} + \frac{Ni}{60} + \frac{Cr}{20} + \frac{Mo}{15} + \frac{V}{10} + 5B$$

If the heat analysis indicates a boron content less than 0.001%, then the product analysis need not include boron, and the boron content can be considered as zero for the $CE(Pcm)$ calculation.

- When the carbon content is greater than 0.12%, the carbon equivalent shall be calculated using the following formula for $CE(IIW)$ [see Note 2]:

$$CE(IIW) = C + \frac{Mn}{6} + \frac{(Cr + Mo + V)}{5} + \frac{(Ni + Cu)}{15}$$

6.1.3.2 Maximum Carbon Equivalent

The carbon equivalent shall not exceed the following:

- For Grade X80 pipe, for all grades of seamless pipe having a specified wall thickness greater than 0.800 in. (20.3 mm), and for pipe designated by the purchaser as high carbon equivalent pipe, the value agreed upon between the purchaser and the manufacturer.
- For pipe not covered in Item a above, a $CE(Pcm)$ of 0.25% or a $CE(IIW)$ of 0.43%, whichever is applicable.

Note 1: The $CE(Pcm)$ formula for low carbon steel is commonly called the Ito-Bessyo formula. $CE(Pcm)$ is in fact the chemical portion of the full formula. Reference: Y. Ito & K. Bessyo, "Weldability Formula of High Strength Steels Related to Heat Affected Zone Cracking," *Journal of Japanese Welding Society*, 1968, 37, (9), 938.

Note 2: The $CE(IIW)$ formula is commonly called the *IIW* [International Institute of Welding] formula. Reference: Technical Report, 1967, IIW doc. IX-535-67.

6.2 MECHANICAL PROPERTIES

6.2.1 Tensile Properties

PSL 1 Grades A25, A, B, X42, X46, X52, X56, X60, X65, and X70 shall conform to the tensile requirements specified in Table 3A.

PSL 2 Grades B, X42, X46, X52, X56, X60, X65, X70, and X80 shall conform to the tensile requirements specified in Table 3B.

Other grades intermediate to the listed grades between X42 and X80 shall conform to tensile requirements agreed upon between the purchaser and the manufacturer, and the requirements shall be consistent with those specified in Table 3A (for PSL 1 pipe) or Table 3B (for PSL2 pipe).

For cold expanded pipe, the ratio of body yield strength and body ultimate tensile strength of each test pipe on which body yield strength and body ultimate tensile strength are determined, shall not exceed 0.93. The yield strength shall be the tensile stress required to produce a total elongation of 0.5% of the gage length as determined by an extensometer. When elongation is recorded or reported, the record or report shall show the nominal width of the test specimen when strip specimens are used and the diameter and gage length when round bar specimens are used, or shall state when full section specimens are used. For Grade A25 pipe, the manufacturer may certify that the material furnished has been tested and meets the mechanical requirements of Grade A25.

6.2.2 Flattening Test Acceptance Criteria

Acceptance criteria for flattening tests shall be as follows:

- For electric welded pipe in grades higher than A25, and laser welded pipe smaller than 12³/₄.
 - For Grade X60 and higher pipe with a specified wall thickness equal to or greater than to 0.500 in. (12.7mm), flatten to two-thirds of the original outside diameter without weld opening. For all other combinations of pipe grade and specified wall thickness, flatten to one-half of the original outside diameter without weld opening.
 - For pipe with a D/t greater than 10, continue flattening to one-third of the original OD without cracks or breaks other than in the weld.
 - For all pipe D/t , continue flattening until opposite walls of the pipe meet; no evidence of lamination or burnt metal shall develop during the entire test.
- For grade A25 welded pipe, flatten to three-fourths of the original OD without weld fracture. Continue flattening to 60% of the original OD without cracks or breaks other than in the weld.

Note 1: For all flattening tests, the weld extends to a distance on each side of the weld line of $\frac{1}{4}$ in (6.4mm) for pipe smaller than size $2\frac{3}{8}$, and $\frac{1}{2}$ in (12.7mm) for pipe size $2\frac{3}{8}$ or larger.

Note 2: For electric welded pipe that is processed through a hot stretch mill and is flattened prior to such treatment, the original outside diameter is as designated by the manufacturer; for all other cases, the original outside diameter is the specified outside diameter.

6.2.3 Bend Tests

Welded Grade A25 pipe of size $2\frac{3}{8}$ and smaller shall be tested according to 9.3.3. No cracks shall occur in any portion of the pipe, and no opening shall occur in the weld.

Note: For all bend tests, the weld extends to a distance on each side of the weld line of $\frac{1}{4}$ in (6.4mm) for pipe smaller than size $2\frac{3}{8}$, and $\frac{1}{2}$ in (12.7mm) for pipe of size $2\frac{3}{8}$.

6.2.4 Manipulation Tests for Submerged-arc, Gas Metal-arc, and Laser Welds

Submerged-arc and gas metal-arc welds in pipe of all sizes, and laser welds in pipe of sizes $1\frac{3}{4}$ and larger, shall be tested by the guided-bend test (see 9.3.4).

6.2.5 Fracture Toughness Tests

6.2.5.1 Charpy Impact Tests for PSL 1

For PSL 1 pipe, Charpy impact testing is not required.

6.2.5.2 Charpy Impact Tests for PSL 2

For pipe in the size and wall thickness combinations given in Table 14, Charpy V-notch tests shall be conducted in accordance with the requirements of 9.10.4 and the following:

- a. The test temperature shall be $+32^{\circ}\text{F}$ (0°C); however, pipe tested at a lower temperature is also acceptable if it meets all other applicable fracture toughness requirements below.
- b. For all grades, the required minimum average (set of three specimens) absorbed energy for each heat based on full size specimens shall be 20 ft-lb (27 J) for transverse specimens or 30 ft-lb (41 J) for longitudinal specimens, whichever is applicable per Table 14.
- c. For all grades, the shear area of each specimen shall be reported for each heat.
- d. For X80 only, the required minimum all-heat average absorbed energy for the entire order item, based on full size Charpy specimens shall be 50 ft-lb (68 J) for transverse specimens; or 75 ft-lb (101 J) for longitudinal specimens, whichever is applicable per Table 14. If the all-heat average of the order does not meet the applicable requirement, the manufacturer shall be responsible for the replacement of heats to bring the average up to the required level.
- e. For X80 only, the required minimum shear area shall be either 40% for each heat and 70% for the all-heat average of the order based on the Charpy test, or 40% for each heat and

60% for the all-heat average based on the drop-weight tear test. The drop-weight tear test option only applies for welded pipe in sizes 20 or larger. If the all-heat average of the order does not meet the required percentage of shear area, the manufacturer shall be responsible for the replacement of heats as necessary to bring the average up to the required level.

6.2.5.3 Supplementary Fracture Toughness Tests

In addition to the requirements in 6.2.6.1 and 6.2.6.2, when so specified on the purchase order, the manufacturer shall conduct fracture toughness tests in accordance with Supplementary Requirement 5 and/or 6 (see SR5 and SR6 of Appendix F) or any combination of these, and shall furnish a report of results showing compliance with the supplementary requirements specified. The purchaser shall specify on the purchase order the testing temperature for SR5 and SR6 and the Charpy V-notch absorbed energy for SR5B.

6.2.6 Metallographic Examination

For PSL 1 electric welded pipe in grades higher than X42, for PSL 2 electric welded pipe in all grades, and for laser welded pipe in all grades, full body normalized pipe excluded, compliance with the requirement in 5.1.3.3 and 5.1.3.4 to heat treat the entire heat affected zone shall be demonstrated by metallographic examination of a weld cross section. Such examinations shall be performed at least once per operating shift (12 hours maximum) and whenever changes of grade, diameter, or wall thickness are made and whenever significant excursions from operating heat treatment conditions are encountered.

7 Dimensions, Weights, Lengths, Defects, and End Finishes

7.1 SPECIFIED DIMENSIONS

Line pipe shall be furnished in the outside diameters and wall thicknesses specified on the purchase order; such dimensions shall be in accordance with one of the following:

- a. As given in Table 4, 5, 6A, 6B, 6C, E-6A, E-6B, or E-6C, whichever is applicable.
- b. By agreement between the purchaser and the manufacturer, intermediate to the values given in Table 6A, 6B, 6C, E-6A, E-6B, or E-6C, whichever is applicable.

7.2 DIAMETER

The outside diameter shall be within the tolerances specified in Tables 7 and 8. For threaded pipe, the outside diameter at the threaded ends shall be such that the thread length, L_4 , and the number of full-crest threads in that length are within the applicable dimensions and tolerances specified in API Standard 5B.

Pipe of sizes 20 and smaller shall permit the passage over the ends, for a distance of 4 in. (101.6 mm), of a ring gage that has a bore diameter not larger than the pipe's specified outside diameter plus the applicable plus tolerance shown in Table 8. For submerged-arc welded pipe, ring gages may be slotted or notched to permit passage of the gage over the weld reinforcement. Ring gage measurements shall be made at least once per 4 hours per operating shift.

Diameter measurements of pipe larger than size 20 shall be made with a diameter tape. Diameter measurements of pipe sizes 20 and smaller shall be made with a snap gage, caliper, or other device that measures actual diameter across a single plane, except that the manufacturer shall have the option of using a diameter tape. Diameter measurements shall be made at least once per 4 hours per operating shift.

Any pipe found to be out of tolerance is cause for individual diameter measurement of all pipe back to the last, and up to the next, two sequential pipes measured and found to be within tolerance.

By agreement between the purchaser and the manufacturer, the tolerances on the outside diameter at the pipe ends may be applied instead to the inside diameter at the pipe ends.

7.3 WALL THICKNESS

Each length of pipe shall be measured for conformance to the specified wall thickness requirements. The wall thickness at any location shall be within the tolerances specified in Table 9, except that the weld area shall not be limited by the plus tolerance. Wall thickness measurements shall be made with a mechanical caliper or with a properly calibrated non-destructive inspection device of appropriate accuracy. In case of dispute, the measurement determined by use of the mechanical caliper shall govern. The mechanical caliper shall be fitted with contact pins having circular cross sections of $1/4$ in. (6.4 mm) diameter. The end of the pin contacting the inside surface of the pipe shall be rounded to a maximum radius of $1\ 1/2$ in. (38.1 mm) for pipe of size $6\ 5/8$ or larger, and to a maximum radius of $d/4$ for pipe smaller than size $6\ 5/8$, with a minimum radius of $1/8$ in. (3.2 mm). The end of the pin contacting the outside surface of the pipe shall be either flat or rounded to a radius of not less than $1\ 1/2$ in. (38.1 mm).

7.4 WEIGHT

Each length of pipe of size $5\ 9/16$ or larger shall be weighed separately; lengths of pipe smaller than size $5\ 9/16$ shall be weighed either individually or in convenient groups, at the option of the manufacturer. For all sizes of pipe, the order item weights and, where applicable, the carload weights shall be determined. Threaded-and-coupled pipe shall be weighed with the couplings screwed on but without thread protectors, except for carload determinations for which proper allowance shall be made for the weight of the thread protectors. Threaded-and-coupled pipe may be weighed before the couplings are attached, provided that allowance is made for the weight of the couplings.

plings are attached, provided that allowance is made for the weight of the couplings.

For plain-end pipe, the weights determined as described above shall conform to the calculated weights, within the tolerances specified in Table 10. For threaded-and-coupled pipe, the weights determined as described above shall conform to the calculated weights or adjusted calculated weights, within the tolerances specified in Table 10.

Full-length calculated weights shall be determined in accordance with the following equation:

$$W_L = (W_{pe} \times L) + e_w$$

where

W_L = calculated weight of a piece of pipe of length L , lb (kg),

w_{pe} = plain-end weight per unit length rounded to the nearest 0.01 lb/ft (0.01 kg/m),

L = length of pipe, including end finish, as defined in 7.5, ft (m),

e_w = weight gain or loss due to end finish, lb (kg).

For plain-end pipe, e_w equals 0.

The plain-end weight per unit length, w_{pe} , shall be calculated using the following equation and rounded to the nearest 0.01 lb/ft (0.01 kg/m):

U.S. Customary unit equation (lb/ft) = $w_{pe} = 10.69 (D - t)t$

SI unit equation (kg/m) = $w_{pe} = 0.024\ 66 (D - t)t$

where

D = specified outside diameter, in. (mm),

t = specified wall thickness, in. (mm).

7.5 LENGTH

Unless otherwise agreed between the purchaser and the manufacturer, pipe shall be furnished in the nominal lengths and within the length tolerances shown in Table 11, as specified on the purchase order. For threaded-and-coupled pipe, the length shall be measured to the outer face of the coupling. The length of threaded-and-coupled pipe may be determined before the couplings are attached, provided that proper allowance is made for the length of the couplings. Each length of pipe shall be measured, except that pipe made in lengths that are uniform within 0.1 ft (0.03 m) need not be individually measured, provided that the accuracy of the length is verified at least once per 4 hours per operating shift. Any pipe found to be out of tolerance is cause for individual measurement of all pipe back to the last, and up to the next, two sequential pipes measured and found to be within tolerance.

The accuracy of length measuring devices for lengths of pipe less than 100 ft (30 m) shall be ± 0.1 ft (0.03 m).

7.6 STRAIGHTNESS

Pipe smaller than size 4 $\frac{1}{2}$ in Grades A25, A, and B shall be reasonably straight. All other pipe shall be randomly checked for straightness; deviation from a straight line shall not exceed 0.2% of the length. Measurement may be made using a taut string or wire from end to end along the side of the pipe, measuring the greatest deviation.

7.7 JOINTERS

When specified on the purchase order, jointers (two lengths of pipe coupled together by the manufacturer or two lengths of pipe welded together by the manufacturer in accordance with the requirements of Appendix A) may be furnished; however, no length used in making a jointer shall be less than 5.0 ft (1.52 m).

For helical seam submerged-arc welded pipe, the junctions of skelp end welds and helical seam welds shall be permitted only at distances greater than 12 in. (304.8 mm) from jointer welds. By agreement between the purchaser and the manufacturer, skelp end welds in finished pipe shall be permitted at jointer welds, provided that there is a circumferential separation of at least 6 in. (152.4 mm) between the junction of the skelp end weld and the jointer weld and the junction of the helical seam and the jointer weld.

Double joints are not within the purview of API Specification 5L. Double joints are defined as lengths of pipe welded together by parties other than the manufacturer or lengths welded together by the manufacturer in accordance with requirements other than those in Appendix A.

7.8 WORKMANSHIP AND DEFECTS

Imperfections of the types described in 7.8.1–7.8.14 that exceed the specified criteria shall be considered defects. The manufacturer shall take all reasonable precautions to minimize recurring imperfections, damage, and defects.

7.8.1 Dents

The pipe shall contain no dents greater than $\frac{1}{4}$ in. (6.4 mm), measured as the gap between the lowest point of the dent and a prolongation of the original contour of the pipe. The length of the dent in any direction shall not exceed one-half the diameter of the pipe. All cold-formed dents deeper than $\frac{1}{8}$ in. (3.2 mm) with a sharp bottom gouge shall be considered a defect. The gouge may be removed by grinding.

7.8.2 Offset of Plate Edges

For pipe with filler metal welds having specified wall thicknesses of 0.500 in. (12.7 mm) and less, the radial offset

(misalignment) of plate edges in the weld seams shall not be greater than $\frac{1}{16}$ in. (1.6 mm). For pipe with filler metal welds having specified wall thicknesses over 0.500 in. (12.7 mm), the radial offset shall not be greater than $0.125 t$ or $\frac{1}{8}$ in. (3.2 mm), whichever is smaller. For electric welded pipe, the radial offset of plate edges plus flash trim shall be no greater than 0.060 in. (1.5 mm). For laser welded pipe, the radial offset of plate edges plus weld reinforcement trim shall be no greater than 0.060 in. (1.5 mm).

7.8.3 Out-of-line Weld Bead for Pipe with Filler Metal Welds

Out-of-line weld bead (off-seam weld) shall not be cause for rejection, provided that complete penetration and complete fusion have been achieved, as indicated by nondestructive inspection.

7.8.4 Height of Outside and Inside Weld Beads—Submerged-arc Welds

The weld bead shall not extend above the prolongation of the original surface of the pipe by more than the following:

Specified Wall Thickness	Maximum Height of Weld Bead
$\frac{1}{2}$ in. (12.7 mm) and under	$\frac{1}{8}$ in. (3.2 mm)
Over $\frac{1}{2}$ in. (12.7 mm)	$\frac{3}{16}$ in. (4.8 mm)

Weld beads higher than permitted by the requirements of this paragraph may be ground to acceptable limits at the option of the manufacturer.

The height of the weld bead shall in no case come below a prolongation of the surface of the pipe (outside or inside the weld bead) except that contouring by grinding, otherwise covered in this specification, shall be permitted.

7.8.5 Height of Flash of Electric Welded Pipe

The outside flash of electric welded pipe shall be trimmed to an essentially flush condition.

The inside flash of electric welded pipe shall not extend above the prolongation of the original inside surface of the pipe more than 0.060 in. (1.5 mm).

7.8.6 Height of Weld Reinforcement of Laser Welded Pipe

The outside weld reinforcement of laser welded pipe shall be trimmed to an essentially flush condition. The inside weld reinforcement of laser welded pipe shall not extend above the prolongation of the original inside surface of the pipe more than 0.060 in. (1.5 mm). Laser welds may have underfills, which are acceptable within the limits of 7.8.13.

7.8.7 Trim of Inside Flash of Electric Welded Pipe and Trim of Inside Weld Reinforcement of Laser Welded Pipe

The depth of groove resulting from removal of the internal flash of electric welded pipe or removal of the internal weld reinforcement of laser welded pipe shall not be greater than that listed below for the various wall thicknesses. Depth of groove is defined as the difference between the wall thickness measured approximately 1 in. (25.4 mm) from the weld line and the remaining wall under the groove.

Specified Wall Thickness (<i>t</i>)	Maximum Depth of Trim
≤ 0.150 in. (3.8 mm)	0.10 <i>t</i>
> 0.150 in. (3.8 mm) and < 0.301 in. (7.6 mm)	0.015 in. (0.4 mm)
≥ 0.301 in. (7.6 mm) and greater	0.05 <i>t</i>

7.8.8 Hard Spots

Any hard spot having a minimum dimension greater than 2 in. (50.8 mm) in any direction and a hardness greater than or equal to 35 HRC (327 HB) shall be rejected. The section of pipe containing the hard spot shall be removed as a cylinder.

The surface of cold-formed welded pipe shall be examined visually to detect irregularities in the curvature of the pipe. When this examination fails to disclose mechanical damage as the cause of the irregular surface but indicates that the irregular surface may be attributed to a hard spot, the hardness and dimensions of the area shall be determined. If hardness and dimensions exceed the aforementioned rejection criteria, the hard spot shall be removed.

7.8.9 Cracks, Sweats, and Leaks

All cracks, sweats, and leaks shall be considered defects.

7.8.10 Laminations (See Note)

Any lamination or inclusion extending into the face or bevel of the pipe and having a visually determined transverse dimension exceeding 1/4 in. (6.4 mm) is considered a defect. Pipe containing such defects shall be cut back until no lamination or inclusion is greater than 1/4 in. (6.4 mm).

Any lamination in the body of the pipe exceeding both of the following is considered a defect:

- a. Greater than or equal to 3/4 in. (19.0 mm) in the minor dimension.
- b. Greater than or equal to 12 in.² (7742 mm²) in area.

Disposition of such defects shall be in accordance with 9.9, Item c or d. No specific inspection by the manufacturer is required unless the purchaser specifies special nondestructive inspection on the purchase order.

Note: A lamination is an internal metal separation creating layers generally parallel to the surface.

7.8.11 Arc Burns

Arc burns are localized points of surface melting caused by arcing between electrode or ground and pipe surface and shall be considered defects (see note).

Disposition of pipe containing arc burns shall be in accordance with 9.7.6, except that removal of defects by grinding shall be subject to the following additional condition. Arc burns may be removed by grinding, chipping, or machining. The resultant cavity shall be thoroughly cleaned and checked for complete removal of damaged material by etching with a 10% solution of ammonium persulfate or a 5% solution of nitral.

Note: Contact marks, defined as intermittent marks adjacent to the weld line, resulting from the electrical contact between the electrodes supplying the welding current and the pipe surface, are not defects.

7.8.12 Undercuts

Undercutting can best be located visually.

a. Minor undercutting on either the inside or the outside of the pipe is defined as follows and is acceptable without repair or grinding:

- 1. Maximum depth of 1/32 in. (0.8 mm) and not exceeding 12.5% of the specified wall thickness with a maximum length of one-half the specified wall thickness and not more than two such undercuts in any 1 ft (0.3 m) of the weld length.
- 2. Maximum depth of 1/64 in. (0.4 mm) any length.

b. Undercutting not classified as minor shall be considered a defect. Disposition shall be as follows:

- 1. Undercut defects not exceeding 1/32 in. (0.8mm) in depth and not exceeding 12.5% of the specified wall thickness shall be removed by grinding in accordance with 9.9, Item a.
- 2. Disposition of undercuts greater in depth than 1/32 in. (0.8mm) or 12.5% of the specified wall thickness shall be in accordance with 9.9, Item b, c, or d.

7.8.13 Underfills

Underfill of laser welded pipe is a depression on the weld face or root surface extending below the adjacent surface of the base metal. Underfills can best be located visually.

a. Underfills on the inside of the pipe shall be considered a defect.

b. Minor underfills on the outside of the pipe are defined as follows and are acceptable without repair or grinding.

- 1. Maximum depth not exceeding 5% of the specified wall thickness with a maximum length of two times the specified wall thickness, with a remaining wall thickness of 87.5% of

| 04
| 04

the specified wall thickness, and not more than two such underfills in any 1 ft (0.3 m) of weld length. Furthermore, the coincident combination of underfills, other imperfections, grinds, and weld trim on the outside and inside surfaces of laser welded pipe shall not reduce the remaining wall thickness to less than that permitted in Table 9.

2. Maximum depth of $1/64$ in. (0.4 mm), any length.

c. Disposition of external underfills that are not classified as minor shall be in accordance with 9.9 except that the length of grind to remove underfills shall not exceed 6 in. (152.4 mm) in any 1 ft (0.30 m) of weld length or 12 in. (0.30 m) in any 5 ft (1.52 m) of weld length. Disposition of internal underfills shall be in accordance with 9.9, Items b, c, or d.

7.8.14 Other Defects

Any OD or ID surface imperfection that has a depth greater than 12.5% of the specified wall thickness shall be considered a defect.

7.9 PIPE ENDS

7.9.1 General

The pipe ends shall be plain, threaded, belled, or prepared for special couplings, as specified on the purchase order. Helical seam pipe shall not be threaded. The inside and outside edges of the ends of all pipe shall be free of burrs.

7.9.2 Threaded Ends (PSL 1 only)

Threaded ends shall conform to the threading, thread inspection, and gaging requirements specified in API Standard 5B. One end of each length of threaded pipe shall be provided with a coupling conforming to the requirements of Section 8, in effect at the date of manufacture of each coupling (see Note 1), and the other end with thread protection conforming to the requirements of 11.2. Couplings shall be screwed onto the pipe handling-tight (see Note 2), except that they shall be applied power-tight if so specified on the purchase order. A thread compound shall be applied to cover the full surface of either the coupling or pipe engaged thread before making up the joint. All exposed threads shall be coated with this thread compound. Unless otherwise specified on the purchase order, the manufacturer may use any thread compound that meets the performance objectives set forth in API RP 5A3. A storage compound of distinct color may be substituted for this thread compound on all exposed threads. Whichever compound is used shall be applied to a surface that is clean and reasonably free of moisture and cutting fluids.

Notes:

1. Unless otherwise specified on the purchase order, it is not mandatory that both the pipe and coupling of each threaded and coupled product be manufactured to the same edition of this specification.

2. Handling-tight shall be defined as sufficiently tight that the coupling cannot be removed except by using a wrench. The purpose of making up couplings handling-tight is to facilitate removal of the couplings for cleaning and inspecting threads and applying fresh thread compound before laying the pipe. This procedure has been found necessary to prevent thread leakage, especially in gas lines, because manufacturer-applied couplings made up power-tight, although leak-proof at the time of makeup, may not always remain so after transportation, handling, and laying.

7.9.3 Plain Ends

Unless otherwise specified on the purchase order, plain-end pipe shall be furnished with ends beveled to an angle of 30 degrees (+ 5 degrees, - 0 degrees) measured from a line drawn perpendicular to the axis of the pipe, and with a root face of $1/16$ in. $\pm 1/32$ in. (1.6 ± 0.8 mm) (see Note). For seamless pipe where internal machining is required to maintain the root face tolerance, the angle of the internal taper, measured from the longitudinal axis, shall be no larger than the following:

Specified Wall Thickness, in. (mm)	Maximum Angle of Taper (degrees)
Less than 0.418 (10.6)	7
0.418 through 0.555 (10.6 through 14.1)	9 $1/2$
0.556 through 0.666 (Greater than 14.1 through 16.9)	11
Over 0.666 (16.9)	14

For the removal of an internal burr on welded pipe larger than size 4 $1/2$, the internal taper, measured from the longitudinal axis, shall be no larger than 7°.

For pipe sizes 2 $3/8$ and larger, the pipe ends shall be cut square within $1/16$ in. (1.6 mm). Pipe ends from each end-finishing machine shall be checked for compliance at least once per 4 hours per operating shift.

Both ends of pipe with filler metal welds shall have the inside reinforcement removed for a distance of approximately 4 in. (101.6 mm) from the end of the pipe.

Note: The purchaser is directed to the applicable code for the recommended angle of pipe bevel.

7.9.4 Belled Ends (PSL 1 only)

When so specified on the purchase order, pipe with specified wall thickness 0.141 in. (3.6 mm) and less shall be furnished with one end belled for bell and spigot joints in accordance with Figure 1. The belled end shall be visually inspected for workmanship and defects.

7.9.5 Ends Prepared for Special Couplings (PSL 1 only)

When so specified on the purchase order, pipe shall be furnished with ends suitable for use with special couplings such as Dresser, Victaulic, or other equivalent special couplings. Such pipe shall be sufficiently free from indentations, projections, or roll marks for a distance of 8 in. (203 mm) from the end of the pipe to permit proper makeup of coupling.

8 Couplings (PSL 1 only)

8.1 MATERIAL

Couplings for Grades A and B pipe shall be seamless and shall be made of a grade of material at least equal in mechanical properties to that of the pipe. Couplings for Grade A25 pipe shall be seamless or welded and shall be made of steel. By agreement between the purchaser and the manufacturer, welded couplings may be supplied on pipe of sizes 14 and larger, if the couplings are properly marked.

8.2 TENSILE TESTS

A tensile test shall be made on each heat of steel from which couplings are produced, and the coupling manufacturer shall maintain a record of such tests. This record shall be open to inspection by the purchaser. If such a test is made on finished couplings, either round specimens proportioned as specified in ASTM E 8, Test Methods for Tension Testing of Metallic Materials, or strip specimens shall be used at the option of the manufacturer.

8.3 DIMENSIONS

Couplings shall conform to the dimensions and tolerances shown in Table 12 (see note) and Figure 2.

Note: Couplings given in Table 12 are suitable for pipe having dimensions as given in Tables 4 and 5.

8.4 INSPECTION

Couplings shall be free from blisters, pits, cinder marks, and other defects that would impair the efficiency of the coupling or break the continuity of the thread.

9 Inspection and Testing

9.1 TEST EQUIPMENT

If test equipment, whose calibration or verification is required under the provisions of the specification, is subjected to unusual or severe conditions sufficient to make its accuracy questionable, recalibration or reverification shall be performed prior to further use of the equipment.

9.2 TESTING OF CHEMICAL COMPOSITION

9.2.1 Heat Analyses

The steel manufacturer shall determine the analysis of each heat of steel used in the manufacture of pipe specified on the purchase order. The analysis so determined shall conform to the requirements of 6.1.1.

For Grade X80, heat analysis limits have not been defined, only product analysis limits.

9.2.2 Product Analyses

9.2.2.1 Sampling Frequency

The manufacturer shall determine the analysis of two samples representing each heat of steel used for the production of pipe under this specification.

9.2.2.2 Sampling Methods

9.2.2.2.1 Seamless Pipe

At the option of the manufacturer, samples used for product analyses shall be taken either from tensile test specimens or from the finished pipe.

9.2.2.2.2 Welded Pipe

At the option of the manufacturer, samples used for product analyses shall be taken from either finished pipe, plate, skelp, tensile test specimens, or flattening test specimens. The location of the samples shall be a minimum of 90° from the weld of longitudinally welded pipe. For helical seam pipe, the sample location shall be at a position not less than one quarter of the distance between adjacent weld convolutions as measured from either edge of the weld. For pipe manufactured from plate or skelp, the product analyses may be made by the supplier of the plate or skelp providing the analyses are made in accordance with the frequency requirement of this specification.

9.2.3 Test Reports

9.2.3.1 When required by the purchaser, for Grade A25, the manufacturer shall certify that the pipe furnished was produced in conformance with the requirements for chemical properties and tests of API Specification 5L.

9.2.3.2 Chemical analyses required by this specification shall be reported to the purchaser when SR15 or PSL 2 is specified.

9.3 TESTING OF MECHANICAL PROPERTIES

9.3.1 Tensile Tests

9.3.1.1 Tensile Test Specimens

As shown in Figure 3, tensile test orientation shall be in the longitudinal direction for all sizes of hot worked or heat treated

seamless pipe and all welded pipe less than size 8⁵/₈. For seamless pipe, a transverse round bar or ring expansion specimen may be substituted for the longitudinal specimen by agreement between the purchaser and manufacturer. For weld pipe and cold expanded seamless pipe size 8⁵/₈ and larger, tensile test orientation shall be in the transverse direction. At the option of the manufacturer, the specimen may be either full section, strip specimen, or round bar specimens as specified in 9.3.1.3, 9.3.1.4, and Figure 4. The type, size, and orientation of the specimens shall be reported. Testing of strip specimens shall be with suitable curved-face testing grips, or flat-face testing grips if the grip areas of the specimens have been machined to reduce the curvature or have been flattened without heating. For strip specimens, the specified width in the gage length shall be either 1¹/₂ in. (38.1 mm) or ³/₄ in. (19.0 mm) for pipe of size 3¹/₂ or smaller; either 1¹/₂ in. (38.1 mm) or 1 in. (25.4 mm) for pipe of size larger than 3¹/₂ up to size 6⁵/₈, inclusive; and 1¹/₂ in. (38.1 mm) for pipe larger than size 6⁵/₈.

Note: Conventionally produced seamless line pipe has been demonstrated to exhibit isotropic behavior with similar mechanical properties in the longitudinal and transverse directions (see API SC5 Agenda Item 4191, Task Group on Line Pipe Minutes, June 2003). However, transverse test results on an individual pipe may exhibit yield and tensile properties different from the longitudinal values. Be aware that flattening of seamless strip tensile specimens will affect the transverse test results and will not reflect the actual transverse properties. The purchaser should determine at the time of purchase whether additional testing in the transverse direction is necessary to meet the design requirements for the specific pipeline design in question.

9.3.1.2 Tensile Testing Frequency

Tensile tests shall be made at the frequency of one test per inspection lot as shown in Table 13.

9.3.1.3 Longitudinal Tensile Tests

At the option of the manufacturer, longitudinal tests may utilize a full section specimen (see Figure 4, Subfigure B), a strip specimen (see Figure 4, Subfigure C), or for pipe with wall thickness greater than 0.750 in. (19.1 mm) a 0.500-in. (12.7-mm) diameter round bar specimen (see Figure 4, Subfigure D). The strip specimen shall be tested without flattening.

9.3.1.4 Transverse Tensile Tests

The transverse tensile properties shall be determined, at the option of the manufacturer, by one of the following methods:

- a. The yield strength, ultimate tensile strength, and elongation values shall be determined on either a flattened rectangular specimen (see Figure 4, Subfigure E) or on a round bar specimen (see Figure 4, Subfigure G).
- b. The yield strength shall be determined by the ring expansion method (see Figure 4, Subfigure A) with the ultimate

strength and elongation values determined from a flattened rectangular specimen.

The same method of testing shall be employed for all lots in an order item. All transverse tensile specimens shall be as shown in Figure 4. All specimens shall represent the full wall thickness of the pipe from which the specimen was cut, except for round bar tensile specimens.

Transverse round bar specimens are to be secured from nonflattened pipe sections. The test specimen size shall be as given in Table 14A, unless the next larger test specimen size is used or unless the manufacturer and purchaser agree to the use of the next smaller test specimen size. For pipe sizes too small to obtain a 0.250 in. (6.4 mm) specimen, round bar tensile test specimens shall not be used.

9.3.1.5 Weld Tensile Tests

Weld tensile test specimens shall be taken at 90° to the weld with the weld at the center as shown in Figures 3 and 4 and shall represent the full wall thickness of the pipe from which the specimen was cut. Weld reinforcement may be removed at the manufacturer's option. Weld tensile tests need not include determination of yield strength and elongation.

9.3.2 Flattening Tests

Flattening tests shall be performed for electric welded, continuous welded, and laser welded pipe. Test specimens shall be at least 2¹/₂ in. (63.5mm) long. Frequency of testing, sample location, test orientation, and applicable pipe sizes shall be as shown in Figure 5. For electric welded pipe that is to be processed through a hot stretch mill, the flattening test specimens shall be obtained either prior to or after such treatment, at the option of the manufacturer.

9.3.3 Bend Tests

One full section specimen of appropriate length, cut from a length of pipe from each lot of 25 tons (22.7 Mg), or fraction thereof, for pipe of nominal size 1.900 and smaller, and from each lot of 50 tons (45.5 Mg), or fraction thereof, for pipe of size 2³/₈ shall be bent cold through 90°, around a mandrel having a diameter not greater than twelve times the outside diameter of the pipe being tested, with the weld located approximately 45° from the point of contact of the specimen with the mandrel.

9.3.4 Guided-Bend Tests

The test specimens shall be taken from the helical or each longitudinal seam weld in a length of pipe from each lot of 50 lengths or less of each combination of specified outside diameter, specified wall thickness, and grade; and from a skelp end weld in a length of pipe from each lot of 50 lengths or less of each combination of specified outside diameter, specified

wall thickness, and grade of finished helical seam pipe containing skelp end welds. The test specimens shall not contain repair welds.

9.3.5 Fracture Toughness Tests

9.3.5.1 Charpy Test Specimens

The Charpy test specimens shall be prepared in accordance with ASTM A 370, Methods and Definitions for Mechanical Testing of Steel Products. The specimen size and orientation shall be as given in Table 14, except that it shall be permissible to use $2/3$ or $1/2$ size test specimens as required when the absorbed energy is expected to exceed 80% of the full scale capacity of the testing machine. The Charpy specimens shall be taken from the body of the pipe. For welded pipe, the location shall be 90° from the weld seam. Notch orientation shall be through the wall thickness as shown in Figure F-3 of Appendix F.

9.3.5.2 Charpy Testing Frequency

The minimum test frequency shall be one test per heat per combination of pipe size and specified wall thickness. An impact test shall consist of three specimens; the reported results shall be the three individual specimen values and the average of the three specimens.

9.3.5.3 Drop-Weight Tear Test Specimen and Test Frequency

When the drop-weight tear test option is selected (see 6.2.5.3), refer to SR6.

9.4 HYDROSTATIC TESTS

9.4.1 Hydrostatic Test Requirements

Each length of pipe shall withstand, without leakage, an inspection hydrostatic test to at least the pressure specified in 9.4.3. Test pressures for all sizes of seamless pipe and for welded pipe in sizes 18 and smaller, shall be held for not less than 5 seconds. Test pressures for welded pipe in sizes 20 and larger shall be held for not less than 10 seconds. For threaded-and-coupled pipe, the test shall be applied with the couplings made up power-tight if power-tight makeup is specified on the purchase order, except that pipe sizes larger than $12^{3/4}$ may be tested in the plain-end condition. For threaded pipe furnished with couplings made up handling-tight, the hydrostatic test shall be made on the pipe in the plain-end or threads-only condition or with couplings applied, unless otherwise agreed by the purchaser and the manufacturer.

9.4.2 Verification of Hydrostatic Test

In order to ensure that every length of pipe is tested to the required test pressure, each tester (except those on which continuous welded pipe is tested) shall be equipped with a recording gage that will record the test pressure and duration of time the pressure is applied to each length of pipe, or shall be equipped with some positive and automatic or interlocking device to prevent pipe from being classified as tested until the test requirements (pressure and time) have been complied with. Such records or charts shall be available for examination at the manufacturer's facility by the purchaser's inspectors. The test pressure measuring device shall be calibrated by means of a dead weight tester, or equivalent, within the 4 months prior to each use. Retention of calibration records shall be as specified in 12.2.

9.4.3 Test Pressures

The minimum test pressure shall be the standard test pressure given in Tables 4, 5, 6A, 6B, 6C, E-6A, E-6B, or E-6C; the alternative test pressure given in Tables 6A, 6B, 6C, E-6A, E-6B, or E-6C if so specified in the purchase order; a pressure higher than standard, at the discretion of the manufacturer unless specifically limited by the purchaser; or a pressure higher than standard, as agreed between the purchaser and the manufacturer (see Note 1). The minimum test pressures for grades, outside diameters, and specified wall thicknesses not listed shall be computed by the equation given in Note 2 below. For all sizes of Grade A25 pipe smaller than $5^{9/16}$ and all sizes of Grade A and B pipe smaller than $2^{3/8}$, the test pressure has been arbitrarily assigned. Where the unlisted wall thickness is intermediate to wall thicknesses whose test pressures have been arbitrarily assigned, the test pressure for the intermediate wall thickness shall be equal to the test pressure specified for the next heavier wall thickness. When computed pressures are not an exact multiple of 10 psi (100 kPa), they shall be rounded to the nearest 10 psi (100 kPa).

When the purchase order specifies a hydrostatic test pressure that will produce a hoop stress greater than 90% of the specified minimum yield strength, by agreement between the purchaser and the manufacturer, the hydrostatic test pressure shall be determined in accordance with Appendix K.

Note 1: The hydrostatic test pressures given herein are inspection test pressures, are not intended as a basis for design, and do not necessarily have any direct relationship to working pressures.

Note 2: The test pressures given in Tables 4, 5, 6A, 6B, 6C, E-6A, E-6B, and E-6C were computed by the following equations (see Footnotes a through d) and rounded to the nearest 10 psi (100 kPa):

U.S. Customary Unit Equation SI Unit Equation

$$P = \frac{2St}{D} \qquad P = \frac{2000St}{D}$$

where

P = hydrostatic test pressure in psi (kPa),

S = fiber stress in psi (MPa), equal to a percentage of the specified minimum yield strength for the various sizes as shown in the tabulation below,

t = specified wall thickness, in. (mm),

D = specified outside diameter, in. (mm).

Grade	Size	Percent of Specified Minimum Yield Strength	
		Standard Test Pressure	Alternative Test Pressure
A25	5 ⁹ /16 ^a	60	—
A	≥ 2 ³ /8 ^b	60	75
B	≥ 2 ³ /8 ^b	60	75
X42 through X80	≤ 5 ⁹ /16	60 ^c	75 ^d
	> 5 ⁹ /16 and ≤ 8 ⁵ /8	60 ^c	75 ^d
	> 8 ⁵ /8 and < 20	85 ^c	85 ^d
	≥ 20	90 ^c	90 ^d

^aTest pressures were limited to 2,800 psi (19 300 kPa). Test pressures for other sizes were established arbitrarily.

^bTest pressures were limited to 2,500 psi (17 200 kPa) for 3¹/₂ and smaller, and to 2,800 psi (19 300 kPa) for sizes larger than 3¹/₂. Test pressures for other sizes were established arbitrarily.

^cTest pressures for Grades X42 through X80 were limited to 3,000 psi (20 700 kPa) to accommodate hydrostatic tester limitations.

^dTest pressures for Grades X42 through X80 were limited to 7,260 psi (50 000 kPa) for sizes < 16 and 3,630 psi (25 000 kPa) for sizes ≥ 16.

9.4.4 Supplementary Hydrostatic Tests

By agreement between the purchaser and the manufacturer, for Grade X42 and higher, the manufacturer shall make additional internal pressure tests, which may involve one or more of the following methods. In all supplementary hydrostatic tests, the formula shown in 9.4.3 shall be used for stress calculations. The conditions of testing shall be as agreed upon.

- Hydrostatic destructive tests in which the minimum length of the specimen is ten times the outside diameter of the pipe, but need not exceed 40 ft (12.2 m).
- Full-length destructive tests made by the hydrostatic pressure water column method.
- Hydrostatic transverse yield strength tests using accurate strain gages (see note).

Note: Acceptable gages are the roller-chain ring-expansion gage, the metallic bonded resistance strain gage, or other suitable gages of similar accuracy.

9.5 DIMENSIONAL TESTING

The accuracy of all measuring instruments used for acceptance or rejection, except ring and plug thread gages and weighing devices, shall be verified at least once per operating shift (12 hours maximum).

Verifying the accuracy of measuring devices such as snap gages and drift mandrels shall consist of inspection for wear and conformance to specified dimensions. Verifying the accuracy of rules, length measuring tapes, and other nonadjustable measuring devices shall consist of a visual check for legibility of markings and general wear of fixed reference points. The adjustable and nonadjustable designation of measuring devices utilized by the manufacturer shall be documented.

The verification procedure for working ring and plug thread gages shall be documented. The accuracy of all weighing devices shall be verified at periods not to exceed those required by the manufacturer's documented procedure in accordance with National Institute of Standards and Technology (NIST) standards or equivalent regulations in the country of manufacture of products made to this specification.

If measuring equipment, whose calibration or verification is required under the provisions of the specification, is subjected to unusual or severe conditions sufficient to make its accuracy questionable, recalibration or reverification shall be performed before using the equipment.

9.6 SURFACE INSPECTION

Except as allowed by 9.6.2, each pipe shall be visually inspected to detect surface defects (see 7.8). Such inspection shall be over the entire external surface. Visual inspection shall cover as much of the internal surface as is practical.

Note: Typically, the entire inside surface of large diameter welded pipe with filler metal is visually inspected from inside the pipe.

9.6.1 It shall be permissible for visual inspection to be replaced by other inspection methods that have a demonstrated capability of detecting surface defects.

9.7 VISUAL INSPECTION

Visual inspection shall be conducted by personnel who are trained to detect and evaluate surface imperfections, and have visual acuity that meets the applicable requirements of ASNT SNT-TC-1A, or equivalent.

9.8 NONDESTRUCTIVE INSPECTION

9.8.1 Qualification of Personnel

As a minimum, ASNT SNT-TC-1A, or equivalent, shall be the basis of qualification for NDT personnel (excluding the

visual method). Personnel shall be requalified for any method previously qualified, if they have not performed NDT in that method for a period exceeding 12 months. NDT shall be conducted by Level I, II, or III personnel.

Evaluation of indications shall be performed by Level I personnel under the supervision of Level II or III personnel, or by Level II or III personnel.

9.8.2 Standard Practices for Inspection

Except as allowed in Table 26, for other than surface inspection (see 9.6) and wall thickness verification, the required inspections shall be performed in accordance with the applicable ASTM standards, or equivalent, as follows:

a. Electromagnetic (flux leakage)	E 570
b. Electromagnetic (eddy-current)	E 309
c. Ultrasonic	E 213
d. Ultrasonic (weld seam)	E 273
e. Magnetic Particle	E 709
f. Radiographic	E 94
g. Liquid Penetrant	E 165

9.8.3 Methods of Inspection

Except for Grade A25 pipe, the weld seams of welded pipe of sizes 2³/₈ and larger shall be nondestructively inspected full length (100%) for the entire thickness, in accordance with the applicable methods given in Table 24. In addition, the skelp end weld in finished helical seam pipe shall be nondestructively inspected in accordance with the applicable methods given in Table 24.

All PSL 2 seamless pipe and PSL 1 Grade B quenched and tempered seamless pipe (see 5.4) shall be nondestructively inspected full length (100%) in accordance with the applicable methods given in Table 25. When specified on the purchase order, other PSL 1 seamless pipe shall be nondestructively inspected in accordance with the applicable methods given in Table 25.

By agreement between the purchaser and the manufacturer and when specified on the purchase order, electric welds and laser welds shall be nondestructively inspected in accordance with SR17 (see Appendix F).

The location of equipment in the manufacturer's facility shall be at the discretion of the manufacturer, except that

- a. required nondestructive inspection of weld seams of cold expanded pipe shall be performed after cold expansion; and
- b. required nondestructive inspection of seamless pipe shall take place after all heat treating and cold expansion operations, if performed, but may take place before cropping, beveling, and end sizing.

9.8.3.1 Pipe End Weld Inspection

When an automated ultrasonic or electromagnetic inspection system (combined equipment, operating procedures, and personnel) is applied to meet the requirements of 9.8.3, the weld at the end of the pipe that is not covered by the automated inspection system shall be inspected for defects by ultrasonic angle beam or radiographic methods as appropriate.

For submerged-arc welded pipe and gas metal-arc welded pipe, the weld at each pipe end for a minimum distance of 8 in. (200 mm) shall be inspected by radiographic methods. The results of such radiographic inspection shall be recorded on either film or another imaging medium.

9.8.3.2 Pipe End Inspection—Seamless

When an automated ultrasonic or electromagnetic inspection system (combined equipment, operating procedures, and personnel) is applied to meet the requirements of 9.8.3, the end of the pipe that is not covered by the automated inspection system shall be inspected for defects either by ultrasonic angle beam or magnetic particle methods, at the option of the manufacturer.

9.8.4 Radiological Inspection—Weld Seams

9.8.4.1 Radiological Inspection Equipment

The homogeneity of weld seams examined by radiological methods shall be determined by means of X-rays directed through the weld material in order to create a suitable image on a radiographic film, a fluorescent screen, or another X-ray imaging medium, provided that the required sensitivity is demonstrated.

9.8.4.2 Radiological Sensitivity Reference Standard

Unless otherwise specified on the purchase order, the reference standard shall be the ASTM hole-type image quality indicator (IQI) described in 9.8.4.3, the ASTM wire-type image quality indicator described in 9.8.4.4, or the ISO wire-type image quality indicator described in 9.8.4.4. By agreement between the purchaser and the manufacturer, other standard image quality indicators may be used, provided that an equivalent or better sensitivity is achieved.

9.8.4.3 ASTM Hole-type Image Quality Indicator

When ASTM hole-type image quality indicators are used, they shall be in accordance with ASTM Standard E 1025. The image quality indicator shall be placed parallel and adjacent to the weld, on shim material that is radiologically similar to the pipe material and is sufficiently thick to be capable of providing a film density at the IQI location that approximates the film density at the adjacent weld seam location. For fluoro-

scopic inspection, the thickness of the image quality indicator used shall be as given in Table 15 for the applicable weld thickness. For radiographic inspection, the thickness of the image quality indicator used shall be as given in Table 16 for the applicable weld thickness.

9.8.4.4 Wire-type Image Quality Indicators

When ISO wire-type image quality indicators are used, they shall be Fe 1/7, Fe 6/12, or Fe 10/16, in accordance with ISO Standard 1027, and the essential wire diameters shall be as given in Tables 17 and 18 for the applicable weld and wall thicknesses. When ASTM wire-type image quality indicators are used, they shall be in accordance with ASTM Standard E 747, and the essential wire diameters shall be as given in Tables 19 and 20 for the applicable weld and wall thicknesses. The image quality indicator used shall be placed across the weld at a location representative of full weld reinforcement and shall contain both essential wire diameters; alternatively, two image quality indicators shall be used, one placed across the weld and the other placed on the base metal.

9.8.4.5 Verification of Standardization

For dynamic methods at operational speeds, an image quality indicator shall be used to check the sensitivity and adequacy of the technique on one pipe in every lot of 50 pipe, but at least once per 4 hours per operating shift. For initial adjustment of the technique using the image quality indicator, the pipe may be held in a stationary position. For film radiographic methods, an image quality indicator shall appear on each exposure.

For hole-type IQIs, proper definition and sensitivity is attained when the essential hole is clearly visible to the operator. For wire-type IQIs, proper definition and sensitivity is attained when the essential wire diameters of the image quality indicator used are clearly visible to the operator in the applicable area (weld or pipe body).

9.8.4.6 Acceptance Limits for Radiological Inspection

Radiological inspection shall be capable of detecting weld imperfections and defects as described in 9.8.4.7 and 9.8.4.8.

9.8.4.7 Imperfections Observed During Radiological Inspection

The maximum acceptable size and distribution of slag inclusion and/or gas pocket imperfections are given in Tables 21 and 22 and Figures 7 and 8 (see note).

The important factors to be considered in determining if imperfections are acceptable are the size and spacing of the imperfections and the sum of their diameters in an established distance. For simplicity, the distance is established as any 6-in. (150-mm) length. Imperfections of this type usually occur

in an aligned pattern, but no distinction is made between aligned and scattered patterns. Also, the distribution pattern may be of assorted sizes.

Note: Unless the imperfections are elongated, it cannot be determined with assurance whether the radiological indications represent slag inclusions or gas pockets. Therefore, the same limits apply to all circular-type imperfections.

9.8.4.8 Defects Observed During Radiological Inspection

Cracks, lack of complete penetration, lack of complete fusion, and imperfections greater in size and/or distribution than shown in Tables 21 and 22 and Figures 7 and 8, as indicated by radiological inspection, shall be considered defects.

Pipe containing such defects shall be given any of the dispositions specified in 9.9.

9.8.4.9 Traceability of Film Radiographs

Radiographs shall be traceable to the pipe identity.

9.8.5 Ultrasonic and Electromagnetic Inspection

9.8.5.1 Equipment

Equipment utilizing ultrasonic or electromagnetic principles and capable of continuous and uninterrupted inspection of the weld seam of welded pipe or the outside and/or inside surfaces of seamless pipe shall be used, as appropriate. The equipment shall be standardized with an applicable reference standard as described in 9.8.5.2 at least once per 8 hours per operating shift to demonstrate its effectiveness and the inspection procedures. The equipment shall be adjusted to produce well-defined indications when the reference standard is inspected in accordance with 9.8.5.2.

For welded pipe, the equipment shall be capable of inspecting through the entire thickness of the weld seam as follows:

- for electric welded pipe and laser welded pipe, the weld line plus $1/16$ inch (1.6 mm) of adjacent parent metal on each side of the weld line.
- for pipe welded with filler metal, the weld metal plus $1/16$ in. (1.6 mm) of adjacent parent metal on each side of the weld metal.

Note: Restrictions on residual magnetism in pipe are given in 9.8.7.

9.8.5.2 Ultrasonic and Electromagnetic Inspection Reference Standards

Each reference standard shall have its outside diameter and wall thickness within the tolerances specified for the production pipe to be inspected and may be of any convenient length as determined by the manufacturer.

Reference standards shall contain one or more machined notches or one or more radially drilled holes as specified in Table 26.

Reference indicators shall be separated by a distance sufficient to produce separate and distinguishable signals.

Reference standards shall be identified. The dimensions and type of reference indicators shall be verified by a documented procedure.

The manufacturer shall use a documented procedure to establish the reject threshold for ultrasonic or electromagnetic inspection. The applicable reference indicators given in Table 26 shall be capable of being detected under normal operating conditions. Such capability shall be demonstrated dynamically, either on-line or off-line at the option of the manufacturer, using a speed of movement between the pipe and the transducer that simulates the inspection to be used for the production pipe.

When a drilled hole is used to establish the reject threshold for electromagnetic inspection of sizes $2\frac{3}{8}$ and larger where the intended application is

- a. the inspection of the weld seam of welded pipe; or
- b. the concurrent inspection of the OD and ID surfaces of seamless pipe.

It shall additionally be verified that the equipment as so standardized produces indications, from both ID and OD notches in the reference standard, that are equal to or greater than the reject threshold established using the drilled hole.

9.8.5.3 Records Verifying System Ability

Inspection system records shall be maintained to document the verification of the system abilities in detecting reference indicators as stated in 9.8.5.2. These records shall include standardization and operating procedures, equipment description, personnel qualifications, and dynamic test data demonstrating the system abilities for detecting the reference indicators.

9.8.5.4 Acceptance Limits

Table 23 gives the height of acceptance limit signals produced by reference indicators.

For welded pipe, any imperfection that produces a signal greater than the applicable acceptance limit signal given in Table 23 shall be considered a defect unless the imperfection causing the indication is a surface imperfection that is not a defect as described in 7.8.

For seamless pipe, any surface imperfection that produces a signal greater than the applicable acceptance limit signal given in Table 23 shall be considered a defect unless the imperfection causing the indication is not a defect as described in 7.8.

In addition, for gas metal-arc welds, any continuous indication greater than 1 in. (25 mm) in length, regardless of sig-

nal height, but greater than the background noise shall be reinspected by radiographic methods in accordance with 9.8.4.1 through 9.8.4.8 or by other techniques as agreed upon between the purchaser and the manufacturer.

9.8.5.5 Disposition of Defects Observed During Ultrasonic and Electromagnetic Inspection

Pipe containing defects shall be given any of the dispositions specified in 9.9.

9.8.5.6 Weld Repair

Defects in weld seams made with filler metal found by ultrasonic methods of inspection may be repaired by welding and reinspected nondestructively in accordance with Appendix B.

For PSL 1 pipe, defects in weld seams made without filler metal found by ultrasonic or electromagnetic methods of inspection may be repaired by welding and reexamined nondestructively in accordance with Appendix B, only by agreement between the purchaser and the manufacturer.

For PSL 2 pipe, defects in weld seams made without filler metal shall not be repaired by welding.

9.8.6 Magnetic Particle Inspection

9.8.6.1 Magnetic Particle Inspection of Seamless Pipe

When magnetic particle inspection is employed to inspect for longitudinal defects, the entire outside surface shall be inspected. The depth of all imperfections revealed by magnetic particle inspection shall be determined; and when found to be greater than 12.5% of the specified wall thickness, shall be considered a defect. Pipe containing defects shall be given any of the dispositions specified in 9.9.

9.8.6.2 Equipment

The equipment used for magnetic particle inspection shall produce a magnetic field of sufficient intensity to indicate imperfections of the following character in the external surface of the pipe: cracks, seams, and slivers.

9.8.6.3 Magnetic Particle Inspection Reference Standard

If requested by the purchaser, arrangements shall be made by the manufacturer to perform a demonstration for the purchaser's representative during production of the purchaser's order. Such demonstration shall be based on pipe in process or sample lengths of similar pipe retained by the manufacturer for that purpose that exhibit natural or artificially produced defects of the character stated in 9.8.6.2.

9.8.6.4 Acceptance Limits

The manufacturer shall mark each magnetic particle indication and subsequently explore each indication with respect to the depth of the imperfection. Imperfections that require grinding or chipping to determine their depth shall be completely removed by grinding, or by cutting off, or may be repaired by welding and reinspected nondestructively in accordance with Appendix B.

9.8.7 Residual Magnetism Measurement Requirements

The requirements of this paragraph apply only to testing within the pipe manufacturing facility. Measurements of residual magnetism on pipe, subsequent to leaving the pipe manufacturing facility, may be affected by procedures and conditions imposed on the pipe during and after shipment.

- a. The longitudinal magnetic field shall be measured on plain-end pipe of sizes 6⁵/₈ and larger, and all smaller plain-end pipe that is inspected full length by magnetic methods or is handled by magnetic equipment prior to loading. Such measurements shall be taken on the root face or square cut face of finished plain-end pipe.
- b. Measurements shall be made using a Hall-effect gaussmeter or other type of calibrated instrument. However, in case of dispute, measurements made with a Hall-effect gaussmeter shall govern. The gaussmeter shall be operated in accordance with written instructions demonstrated to produce accurate results.
- c. Measurements shall be made on each end of a pipe to be selected at least once per 4 hours per operating shift.
- d. Pipe magnetism shall be measured subsequent to any inspection that utilizes a magnetic field, prior to loading for shipment from the manufacturer's facility. For pipe handled with electromagnetic equipment after measurement of magnetism, such handling shall be performed in a manner demonstrated not to cause residual magnetism in excess of the levels stipulated in Item e.
- e. As a minimum, four readings shall be taken approximately 90° apart around the circumference of each end of the pipe. The average of the four readings shall not exceed 30 gauss (3.0 mT), and no one reading shall exceed 35 gauss (3.5 mT) when measured with a Hall-effect gaussmeter, or equivalent values when measured with other types of instruments.
- f. Any pipe that does not meet the requirements of Item e, shall be considered defective. In addition, all pipe produced between the defective pipe and the last acceptable pipe shall be individually measured. Alternatively, if the pipe production sequence is documented, pipe may be measured in reverse sequence beginning with the pipe produced prior to the defective pipe until at least three consecutively produced pipes meet the requirements; pipe produced prior to the three acceptable pipes need not be measured.

Pipe produced after the defective pipe shall be measured individually until at least three consecutive pipes meet the requirements.

Measurements made on pipe in stacks or bundles are not considered valid.

All defective pipe shall be demagnetized full length, and remeasured until at least three consecutive pipes meet the requirements.

9.9 DISPOSITION OF PIPE CONTAINING DEFECTS

Pipe containing a defect shall be given one of the following dispositions:

- a. The defect shall be removed by grinding in such a way that the ground area blends in smoothly with the contour of the pipe. Complete removal of the defect shall be verified, and the wall thickness in the ground area shall be as specified in 7.3. (For arc burns, see also 7.8.11.)
- b. The defective area shall be repaired by welding in accordance with Appendix B, except that, for PSL 2 pipe, defects in pipe body or in seam welds made without filler metal shall not be repaired by welding.
- c. The section of pipe containing the defect shall be cut off within the limits of requirements on length.
- d. The entire pipe shall be rejected.

9.10 TEST METHODS

9.10.1 Methods of Chemical Analysis

Methods and practices relating to chemical analysis shall be performed in accordance with ASTM A 751, Methods, Practices, and Definitions for Chemical Analysis of Steel Products. Calibrations performed shall be traceable to established standards.

9.10.2 Tensile Test

9.10.2.1 Test Method

The tensile testing procedure shall conform to the requirements of ASTM A 370, Methods and Definitions for Mechanical Testing of Steel Products. All tensile tests, except transverse weld and ring tests, shall include yield strength, ultimate tensile strength, and elongation determinations and shall be performed with the specimens at room temperature. The strain rate shall be in accordance with the requirements of ASTM A 370.

9.10.2.2 Equipment

Tensile test machines shall have been calibrated within 15 months preceding any test in accordance with the procedures of ASTM E 4, Practices for Load Verification of Testing Machines. Where yield strength is determined by the use of

extensometers, such extensometers shall be calibrated within the preceding 15 months in accordance with the procedures of ASTM E 83, Method of Verification and Classification of Extensometers.

9.10.3 Guided-Bend Test

One face-bend and one root-bend specimen, both conforming to Figure 9, shall be bent approximately 180° in a jig substantially in accordance with Figure 11. For any combination of specified outside diameter, specified wall thickness, and grade, the maximum value for jig dimension A in Figure 10 may be calculated using the equation shown. The manufacturer shall use a jig based on this dimension, or a smaller dimension at his option; however, to minimize the number of jigs required, standard values for dimension A have been selected for pipe sizes 12³/₄ and larger. These values are listed for each size, specified wall thickness, and grade in Appendix G. For intermediate grades or specified wall thicknesses, the next smaller standard value for dimension A shall be used. When dimension A is greater than 9 in. (228.6 mm), the length of the specimen required to contact the male die need not exceed 9 in. (228.6 mm). For pipe with wall thickness over 0.750 in. (19.1 mm), a reduced wall specimen as shown in Figure 10 may be used at the option of the manufacturer. Reduced wall specimens shall be tested in a jig with the A dimension calculated for 0.750 in. (19.1 mm) wall pipe of the appropriate size and grade. The specimens (a) shall not fracture completely; (b) shall not reveal any cracks or ruptures in the weld metal greater than 1/8 in. (3.2 mm) in length regardless of depth; and (c) shall not reveal any cracks or ruptures in the parent metal, heat affected zone, or fusion line longer than 1/8 in. (3.2 mm) and deeper than 12.5% of the specified wall thickness; except cracks that occur at the edges of the specimen and are less than 1/4 in. (6.4 mm) long shall not be cause for rejection in (b) or (c) above regardless of depth.

9.10.4 Charpy Test

Charpy tests shall be conducted in accordance with ASTM A 370, except that the individual absorbed energy test value (actual for full-size specimens, and converted for subsize specimens) is required to be not less than three-fourths of the required minimum average absorbed energy value specified for full-size specimens.

For purposes of determining conformance with these Charpy V-notch fracture toughness requirements, observed and calculated values shall be rounded to the nearest whole number in accordance with the rounding method of ASTM E 29, Practice for Using Significant Digits in Test Data to Determine Conformance with Specifications. Observed values that are rounded will be referred to as individual readings.

For tests using subsize specimens to determine absorbed energy, the observed individual readings and the calculated average of the three individual readings per test shall be con-

verted to full-size equivalent values by dividing such readings by the ratio of the specimen width tested to the full-size specimen width. For acceptance, full-size equivalent values shall meet the applicable requirements specified for full-size specimens (see 6.2.5.2, 6.2.5.3, and the first paragraph above).

9.11 INVALIDATION OF TESTS

9.11.1 If the elongation of any tensile test specimen is less than that specified and any part of the fracture takes place outside of the middle half of the gage length or in a punched or scribed mark within the reduced section, the test is considered invalid and a replacement test shall be allowed.

9.11.2 For any of the mechanical tests in Section 6, any test specimen that shows defective preparation or material imperfections unrelated to the intent of the particular mechanical test, whether observed before or after testing, may be discarded and replaced by another specimen from the same length of pipe.

9.12 RETESTS

9.12.1 Recheck Analyses

If the product analyses of both samples representing the heat fail to conform to the specified requirements, at the manufacturer's option either the heat shall be rejected or the remainder of the heat shall be tested individually for conformance to the specified requirements. If the product analysis of only one of the samples representing the heat fails to conform to the specified requirements, at the manufacturer's option either the heat shall be rejected or two recheck analyses shall be made using two additional samples from the heat. If both recheck analyses conform to the specified requirements, the heat shall be accepted, except for the pipe, plate, or skelp from which the initial sample that failed was taken. If one or both recheck analyses fail to conform to the specified requirements, at the manufacturer's option either the heat shall be rejected or the remainder of the heat shall be tested individually for conformance to the specified requirements.

For such individual testing, analyses for only the rejecting element or elements need be determined.

Samples for recheck analyses shall be taken in the same location as specified for product analysis samples.

9.12.2 Retests

If the tensile test specimen representing a lot of pipe fails to conform to the specified requirements, the manufacturer may elect to retest two additional lengths from the same lot. If both retested specimens conform to the specified requirements, all the lengths in a lot shall be accepted, except the length from which the initial specimen was taken. If one or both of the retested specimens fail to conform to the specified requirements, the manufacturer may elect to individually test

the remaining lengths in the lot, in which case determinations are required only for the particular requirements with which the specimens failed to comply in the preceding tests. Specimens for retest shall be taken in the same manner as the specimen that failed to meet the minimum requirements.

9.12.3 Flattening Retest

Flattening retest provisions are as follows:

- a. Nonexpanded electric welded pipe in grades higher than A25 and nonexpanded laser welded pipe smaller than 12³/₄, produced in single lengths—The manufacturer may elect to retest any failed end until the requirements are met, providing the finished pipe is not less than 80% of its length after initial cropping.
- b. Nonexpanded electric welded pipe produced in grades higher than A25 and nonexpanded laser-welded pipe smaller than 12³/₄, produced in multiple lengths—The manufacturer may elect to retest each end of each individual length if any test fails. The retests for each end of each individual length shall be made with the weld alternately at 0° and 90°.
- c. Cold-expanded electric welded pipe in grades higher than A25; all welded Grade A25 in sizes 27/8 and larger; and cold-expanded laser welded pipe smaller than size 12³/₄—The manufacturer may elect to retest one end from each of two additional lengths of the same lot. If both retests are acceptable, all lengths in the lot shall be accepted, except the original failed length. If one or both retests fail, the manufacturer may elect to repeat the test on specimens cut from one end of each of the remaining individual lengths in the lot.

9.12.4 Bend Retest

If the specimen fails to conform to the specified requirements, the manufacturer may elect to make retests on specimens cut from two additional lengths from the same lot. If all retest specimens conform to the specified requirements, all lengths in the lot shall be accepted, except the length from which the initial specimen was taken. If one or more of the retest specimens fail to conform to the specified requirements, the manufacturer may elect to repeat the test on specimens cut from the individual lengths remaining in the lot.

9.12.5 Guided-Bend Retest

If one or both of the guided-bend specimens fail to conform to the specified requirements, the manufacturer may elect to repeat the tests on specimens cut from two additional lengths of pipe from the same lot. If such specimens conform to the specified requirements, all lengths in the lot shall be accepted, except the length initially selected for test. If any of the retested specimens fail to pass the specified requirements, the manufacturer may elect to test specimens cut from the individual lengths remaining in the lot. The manufacturer

may also elect to retest any length that has failed to pass the test by cropping back and cutting two additional specimens from the same end. If the requirements of the original test are met by both of these additional tests, that length shall be acceptable. No further cropping and retesting is permitted. Specimens for retests shall be taken in the same manner as specified in 9.10.3.

9.12.6 Charpy Retests

In the event that a set of Charpy test specimens fails to meet the acceptance criteria, the manufacturer may elect to replace the lot of material involved or alternatively to test two more lengths from that lot. If both of the new tests meet the acceptance criteria, then all pipe in that heat, with the exception of the original selected length, shall be considered to meet the requirement. Failure of either of the two additional tests shall require testing of each length in the lot for acceptance.

9.13 REPROCESSING

If any mechanical property test result for a lot of pipe, as defined in 9.3, fails to conform to the applicable requirements, the manufacturer may elect to heat treat the lot of pipe in accordance with the requirements of 5.4, consider it a new lot, test it in accordance with all requirements of 6.2 and 9.3, SR5, and SR6 that are applicable to the order item, and proceed in accordance with the applicable requirements of this specification. After one reprocessing heat treatment, any additional reprocessing heat treatment shall be subject to agreement with the purchaser.

For non-heat treated pipe, any reprocessing heat treatment shall be subject to agreement with the purchaser. For heat treated pipe, any reprocessing with a different type of heat treatment (see 5.4) shall be subject to agreement with the purchaser.

10 Marking

10.1 GENERAL

Pipe and pipe couplings manufactured in conformance with this specification shall be marked by the manufacturer as specified herein (see note).

Note: Users of this specification should note that there is no longer a requirement for marking a product with the API monogram. API continues to license use of the monogram on products covered by this specification, but it is administered by the staff of the Institute separately from the specification. The policy describing use of the monogram is contained in Appendix I. No other use of the monogram is permitted. Licensees mark products in conformance with Section 10 or Appendix I and nonlicensees mark products in conformance with Section 10.

10.1.1 The required marking on pipe shall be as specified hereinafter.

10.1.2 The required marking on couplings shall be die stamped unless otherwise agreed between the purchaser and the manufacturer, in which case it shall be paint stenciled.

10.1.3 Additional markings including those for compatible standards following the specification marking are allowed and may be applied as desired by the manufacturer or as requested by the purchaser.

10.2 LOCATION OF MARKINGS

The location of identification markings shall be as follows:

- a. Size 1.900 or smaller—Die stamped on a metal tag fixed to the bundle or may be printed on the straps or banding clips used to tie the bundle.
- b. Seamless pipe in all other sizes and welded pipe smaller than size 16—Paint stencil on the outside surface starting at a point between 18 in. and 30 in. (457.2 mm and 762 mm) from the end of the pipe in the sequence shown in 10.3, except when agreed between the purchaser and the manufacturer some or all of the markings may be placed on the inside surface in a sequence convenient to the manufacturer.
- c. Welded pipe size 16 or larger—Paint stencil on the inside surface starting at a point no less than 6 in. (152.4 mm) from the end of the pipe in a sequence convenient to the manufacturer, unless otherwise specified by the purchaser.

10.3 SEQUENCE OF MARKINGS

The sequence of identification markings shall be as specified in 10.3.1 through 10.3.10.

10.3.1 Manufacturer

Manufacturer's name or mark shall be the first identifying mark.

10.3.2 Specification

"Spec 5L" shall be marked when the product is in complete compliance with this specification.

10.3.3 Compatible Standards

Products in compliance with multiple compatible standards may be marked with the name of each standard.

10.3.4 Specified Dimensions

The specified outside diameter and the specified wall thickness shall be marked, except that, for the specified outside diameter, any ending zero digits to the right of the decimal need not be included in such markings.

10.3.5 Grade and Class

The symbols to be used are as follows:

Grade (see Note)	Symbol
A25, Class I	A25
A25, Class II	A25R
A	A
B	B
X42	X42
X46	X46
X52	X52
X56	X56
X60	X60
X65	X65
X70	X70
X80	X80

For grades intermediate to X42 and X80, the symbol shall be X followed by the first two digits of the specified minimum yield strength in U.S. Customary units.

By agreement between the purchaser and the manufacturer and when so specified on the purchase order, the grade shall be identified by color in accordance with SR3 (see Appendix F).

Note: See 1.3 for limitations on downgrading.

10.3.6 Product Specification Level

The symbols to be used are as follows:

- a. PSL 1 PSL1
- b. PSL 2 PSL2

The PSL marking shall be placed immediately after the grade symbol.

10.3.7 Process of Manufacture

The symbols to be used are as follows:

- a. Seamless pipe S
- b. Welded pipe, except continuous E
- c. Welded and laser welded
- d. Continuous welded pipe F
- e. Laser welded pipe L

10.3.8 Heat Treatment

The symbols to be used are as follows:

- a. Normalized or normalized and tempered HN
- b. Subcritical stress relieved HS
- c. Subcritical age hardened HA
- d. Quench and tempered HQ

10.3.9 Test Pressure

When the specified hydrostatic test pressure is higher than the tabulated pressure (Tables 4, 5, 6A, 6B, 6C, E-6A, E-6B, or E-6C, whichever is applicable), the word "TESTED" shall be marked, immediately followed by the specified test pres-

sure (in pounds per square inch for pipe ordered in U.S. Customary units, or in hundreds of kilopascals for pipe ordered in SI units).

10.3.10 Supplementary Requirements

See Appendix F for supplementary requirements.

10.3.11 Examples

a. Size 14, 0.375 in. (9.5 mm) specified wall thickness, Grade B, PSL 2, seamless, plain-end pipe should be paint stenciled as follows, using the values that are appropriate for the pipe dimensions specified on the purchase order:

AB CO Spec 5L 14 0.375 B PSL2 S

or

AB CO Spec 5L 355.6 9.5 B PSL2 S

b. Size 6⁵/₈, 0.280 in. (7.1 mm) specified wall thickness, Grade B, PSL 1, electric welded, plain-end pipe should be paint stenciled as follows, using the values that are appropriate for the pipe dimensions specified on the purchase order:

AB CO Spec 5L 6.625 0.280 B PSL1 E

or

AB CO Spec 5L 168.3 7.1 B PSL1 E

c. Size 4¹/₂, 0.237 in. (6.0 mm) specified wall thickness, Grade A25, Class I, continuous welded, threaded-end pipe should be paint stenciled as follows, using the values that are appropriate for the pipe dimensions specified on the purchase order:

AB CO Spec 5L 4.5 0.237 A25 PSL1 F

or

AB CO Spec 5L 114.3 6.0 A25 PSL1 F

d. Size 14, 0.375 in. (9.5 mm) specified wall thickness, Grade X70, PSL 2, seamless, quenched and tempered, plain-end pipe should be paint stenciled as follows, using the values that are appropriate for the pipe dimensions specified on the purchase order:

AB CO Spec 5L 14 0.375 X70 PSL2 S HQ

or

AB CO Spec 5L 355.6 9.5 X70 PSL2 S HQ

e. Size 12³/₄, 0.330 in. (8.4 mm) specified wall thickness, Grade X42, PSL 1, seamless plain-end pipe should be paint stenciled as follows, using the values that are appropriate for the pipe dimensions specified on the purchase order:

AB CO Spec 5L 12.75 0.330 X42 PSL1 S

or

AB CO Spec 5L 323.9 8.4 X42 PSL1 S

f. Size 6⁵/₈, 0.216 in. (5.5 mm) specified wall thickness, Grade X42, PSL 1, laser welded, plain-end pipe should be paint stenciled as follows, using the values that are appropriate for the pipe dimensions specified on the purchase order:

AB CO Spec 5L 6.625 0.216 X42 PSL1 L

or

AB CO Spec 5L 168.3 5.5 X42 PSL1 L
g. Size 24, 0.406 in. (10.3 mm) specified wall thickness, Grade X42, PSL 2 helical seam submerged-arc welded plain-end pipe should be paint stenciled as follows, using the values that are appropriate for the pipe dimensions specified on the purchase order:

AB CO Spec 5L 24 0.406 X42 PSL2 E

or

AB CO Spec 5L 610 10.3 X42 PSL2 E

10.4 BUNDLE IDENTIFICATION

For pipe of size 1.900 or smaller, the identification markings specified in 10.3 shall be placed on the tag, strap, or clip used to tie the bundle. For example, size 1.900, 0.145 in. (3.7 mm) specified wall thickness, Grade B, electric welded, plain-end pipe should have the following marking, using the values that are appropriate for the pipe dimensions specified on the purchase order:

AB CO Spec 5L 1.9 0.145 B PSL1 E

or

AB CO Spec 5L 48.3 3.7 B PSL1 E

10.5 LENGTH

In addition to the identification markings stipulated in 10.2, 10.3, and 10.4, the length shall be marked as follows, using feet and tenths of a foot for pipe ordered in U.S. Customary units, or meters to two decimal places for pipe ordered in SI units, unless a different measuring and marking format has been agreed upon by the purchaser and the manufacturer:

a. For pipe larger than size 1.900, the length, as measured on the finished pipe, shall be paint stenciled on the outside surface at a location convenient to the manufacturer, or by agreement between the purchaser and the manufacturer, on the inside surface at a convenient location.

b. For pipe of size 1.900 or smaller, the total length of pipe in the bundle shall be marked on the tag, band, or clip.

10.6 COUPLINGS

All couplings in sizes 2³/₈ and larger shall be identified with the manufacturer's name or mark and "Spec 5L".

10.7 DIE STAMPING

Cold die stamping is prohibited on all pipe with specified wall thickness of 0.156 in. (4.0 mm) or less and all pipe of grades higher than A25 and not subsequently heat treated, except by agreement between the purchaser and the manufacturer and when so specified on the purchase order, pipe or plate may be cold die stamped. The manufacturer at his option may hot die stamp [200°F (93°C) or higher] plate or pipe, cold die stamp plate or pipe if it is subsequently heat treated, and cold die stamp couplings. Cold die stamping

shall be done with rounded or blunt dies. All die stamping shall be at least 1 in. (25.4 mm) from the weld for all grades except Grade A25.

10.8 THREAD IDENTIFICATION

At the manufacturer's option, threaded-end pipe may be identified by stamping or stenciling the pipe adjacent to the threaded ends, with the manufacturer's name or mark, "Spec 5B" (to indicate the applicable threading specification), the specified outside diameter of the pipe, and the letters "LP" (to indicate the type of thread). The thread marking may be applied to products that do or do not bear the API monogram. For example, size 6⁵/₈ threaded-end pipe may be marked as follows, using the value that is appropriate for the pipe outside diameter specified on the purchase order:

AB CO Spec 5B 6.625 LP

or

AB CO Spec 5B 168.3 LP

If the product is clearly marked elsewhere with the manufacturer's identification, his name or mark, as above, may be omitted.

10.9 THREAD CERTIFICATION

The use of the letters "Spec 5B" as provided in 10.8 shall constitute a certification by the manufacturer that the threads so marked comply with the requirements in API Standard 5B but should not be construed by the purchaser as a representation that the product so marked is, in its entirety, in accordance with any API specification. Manufacturers who use the letters "Spec 5B" for thread identification are required to have access to properly certified API master pipe gages.

10.10 PIPE PROCESSOR MARKINGS

Pipe heat treated by a processor other than the original pipe manufacturer shall be marked as stipulated in 10.1, 10.2, 10.3, 10.4, 10.5, 10.6, and 10.7. The processor shall remove any marking that does not indicate the new condition of the product as a result of heat treating (such as prior grade identity and original pipe manufacturer's name or logo).

11 Coating and Protection

11.1 COATINGS

Unless otherwise specified in the purchase order, pipe shall be supplied either uncoated (bare) or with a temporary external coating to minimize rusting in transit, at the option of the manufacturer. Temporary coatings should be hard to the touch and smooth, with minimum sags.

If the purchaser requires pipe to be uncoated, or to have a temporary or special coating, the purchase order should so state.

For special coatings, the purchase order should state whether the coating is to be applied full length, or with a specified cutback (uncoated distance at each pipe end). Unless otherwise specified, the manufacturer has the option to leave the pipe ends either coated or uncoated, and the option to apply a temporary coating to the pipe ends.

11.2 THREAD PROTECTORS

On pipe smaller than size 2³/₈, the thread protectors shall be suitable fabric wrappings or suitable metal, fiber, or plastic protectors. On pipe of sizes 2³/₈ and larger, the thread protectors shall be of such design, material, and mechanical strength to protect the thread and end of the pipe from damage under normal handling and transportation conditions. The thread protectors shall cover the full length of the thread on the pipe and exclude water and dirt from the thread during transportation and the period of normal storage. The normal storage period shall be considered approximately one year. The thread forms in protectors shall be such that the pipe threads are not damaged by the protectors. Protector material shall contain no compounds capable of causing corrosion or promoting adherence of the protectors to the threads and shall be suitable for service temperatures of -50°F to +150°F (-46°C to +66°C).

12 Documents

12.1 CERTIFICATION

12.1.1 PSL 1 Certification Requirements

The manufacturer shall, upon request by the purchaser, furnish to the purchaser a certificate of compliance stating that the material has been manufactured, sampled, tested, and inspected in accordance with this specification and has been found to meet the requirements.

A Material Test Report, Certificate of Compliance or similar document printed from or used in electronic form from an electronic data interchange (EDI) transmission shall be regarded as having the same validity as a counterpart printed in the certifier's facility. The content of the EDI transmitted document must meet the requirements of this specification and conform to any existing EDI agreement between the purchaser and supplier.

Where additional information is required, including the results of mechanical testing, SR15 shall be specified on the purchase order (see Appendix F).

12.1.2 PSL 2 Certification Requirements

The manufacturer shall provide to the purchaser certificates of compliance and test results in compliance with SR15.1 (see Appendix F).

12.2 RETENTION OF RECORDS

Tests and inspections requiring retention of records in this specification are shown in Table 27. Such records shall be retained by the manufacturer and shall be made available to the purchaser upon request for a 3-year period after the date of purchase from the manufacturer.

13 Pipe Loading

When the manufacturer is responsible for the shipment of pipe, the manufacturer shall prepare and follow loading diagrams which detail how the pipe is arranged, protected, and secured on trucks, railcars, barges or oceangoing vessels, as applicable. The loading shall be designed to prevent end dam-

age, abrasion, peening, and fatigue cracking. The loading shall comply with any rules, codes, standards, or recommended practices which are applicable. Examples of these may include but are not limited to:

American Association of Railroads—*General Rules Governing the Loading of Commodities on Open Top Cars*

American Association of American Railroads—*Rules Governing the Loading of Steel Products Including Pipe on Open Top Cars*

API RP 5L1—*Recommended Practice for Railroad Transportation of Line Pipe*

API RP 5LW—*Recommended Practice for Transportation of Line Pipe on Barges and Marine Vessels*

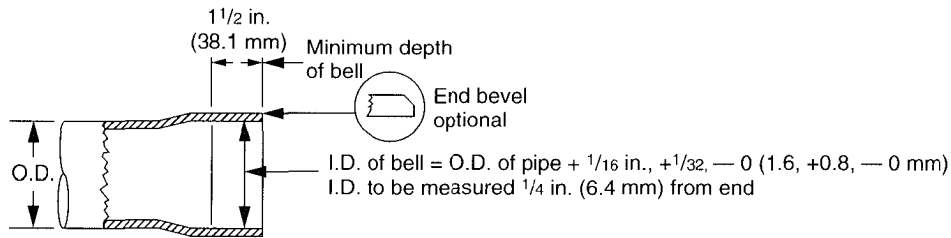
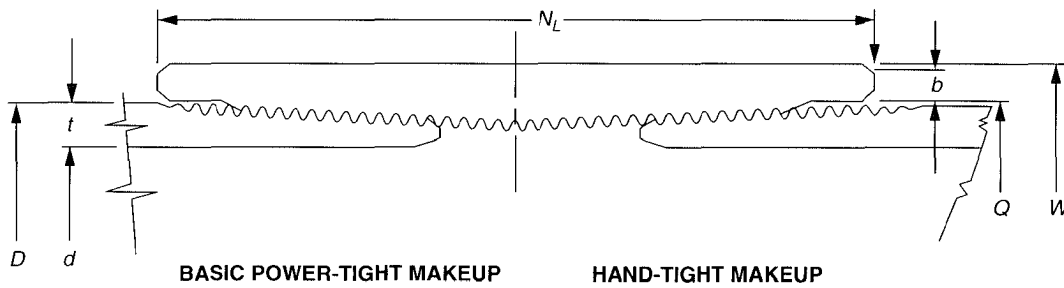
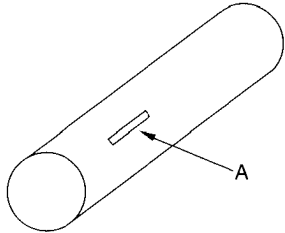
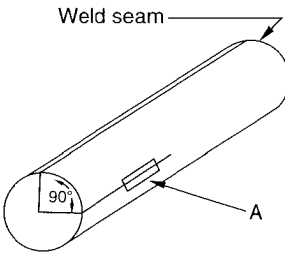
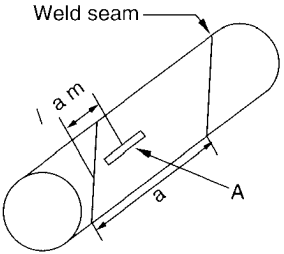
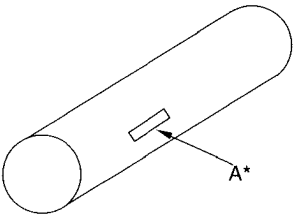
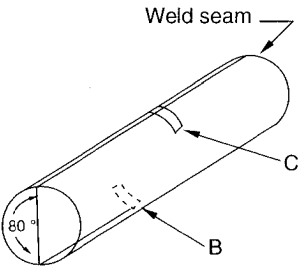
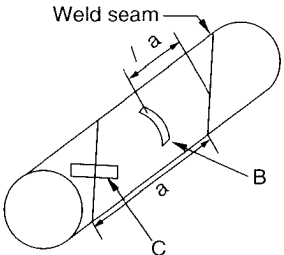

Figure 1—Belled End for Bell and Spigot Joint



Note: See Tables 4 and 5 for pipe dimensions, Table 12 for coupling dimensions, and API Std 5B for thread details.

Figure 2—Line Pipe and Couplings

SIZE	SEAMLESS PIPE	WELDED PIPE	
		Longitudinal Seam	Helical Seam
$< 8^{5/8}$			
$\geq 8^{5/8}$			

Notes:

A = Longitudinal specimen (any circumferential location for seamless).

B = Transverse specimen. For double seam pipe, the specimen shall be taken from a location midway between the welds.

C = Transverse weld specimen.

* For cold expanded seamless pipe size $8^{5/8}$ and larger, all tensile tests shall be in the transverse direction.

Figure 3—Orientation of Tensile Test Specimens

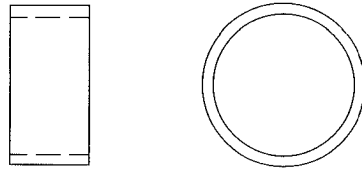

A — Ring Expansion Specimen

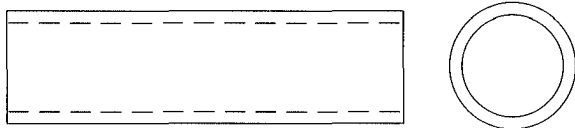

B — Full Section Specimen

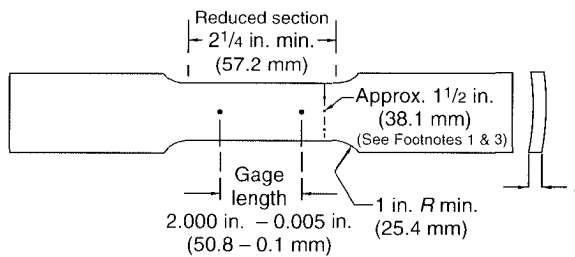

C — Strip Specimen

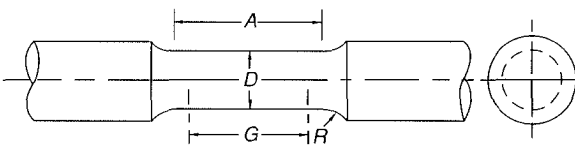

		in.	mm
G	Gage length	2.000 - 0.005	50.8 - 0.1
D	Diameter	0.500 - 0.010	12.7 - 0.2
R	Radius of fillet, min.	3/8	10
A	Length of reduced section, min.	2 1/4	60

D — Round Bar Specimen

For pipe with wall thickness of 0.750 in. (19.1 mm) or greater

LONGITUDINAL SPECIMENS

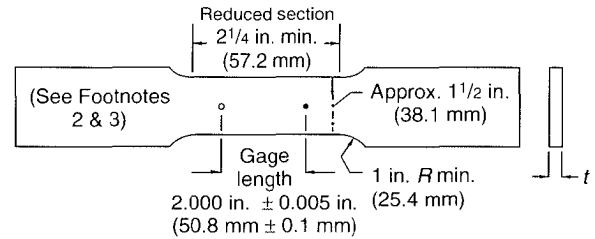

E — Strip Specimen, Base Metal

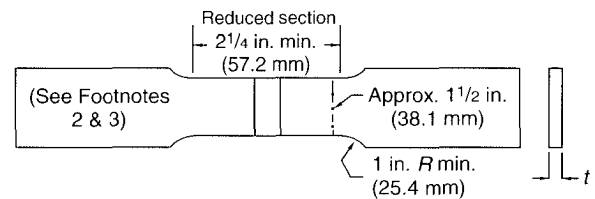

F — Strip Specimen, Weld

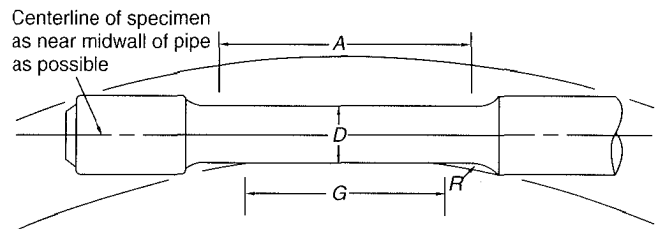

		0.250-in. (6.4-mm) Specimen		0.500-in. (12.7-mm) Specimen		0.350-in. (8.9-mm) Specimen	
		in.	mm	in.	mm	in.	mm
G	Gage length	1.000 - 0.005	25.4 - 0.1	2.000 - 0.005	50.8 - 0.1	1.400 - 0.005	35.6 - 0.1
D	Diameter	0.250 - 0.005	6.4 - 0.1	0.500 - 0.010	12.7 - 0.2	0.350 - 0.007	8.9 - 0.2
R	Radius of fillet, min.	3/16	4.8	3/8	10	1/4	6
A	Length of reduced Section, min.	1 1/4	31.8	2 1/4	60	1 3/4	45

G — Round Bar Specimen

TRANSVERSE SPECIMENS

Notes:

1. See 9.3.1.1 for alternative gage width.
2. Flattening of transverse and weld specimens shall be performed at room temperature.
3. Hot flattening, artificial aging, or heat treatment of tensile specimens is not permitted.

Figure 4—Tensile Test Specimens

ELECTRIC WELDED PIPE GRADES HIGHER THAN A25 AND LASER WELDED PIPE SMALLER THAN SIZE 12³/₄ NONEXPANDED IN MULTIPLE LENGTHS

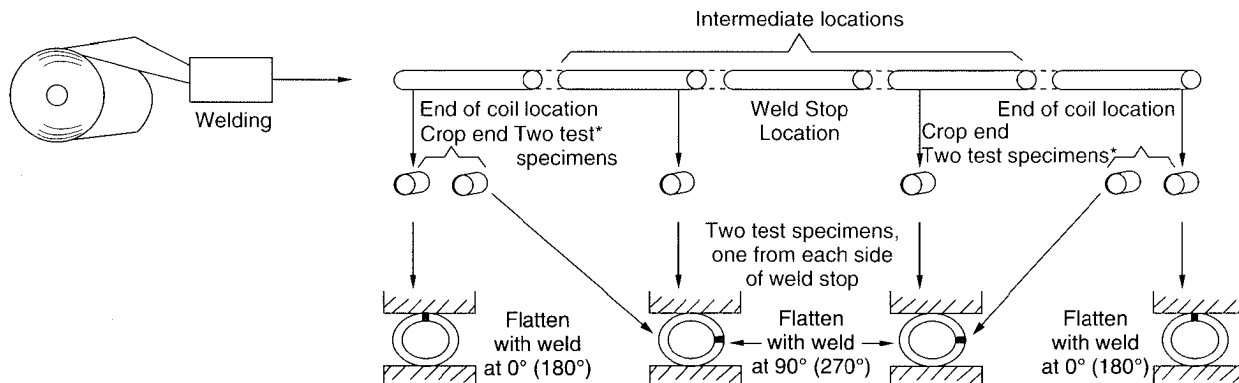

*For 0° (180°) orientation tests, intermediate locations may be substituted for coil end locations.

ELECTRIC WELDED PIPE IN GRADES HIGHER THAN A25 NONEXPANDED PRODUCED IN SINGLE LENGTHS

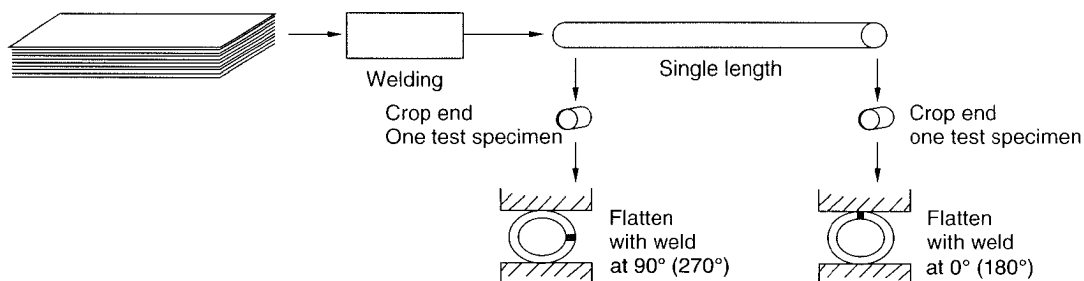

GRADE A25 WELDED PIPE SIZE 2⁷/₈ AND LARGER

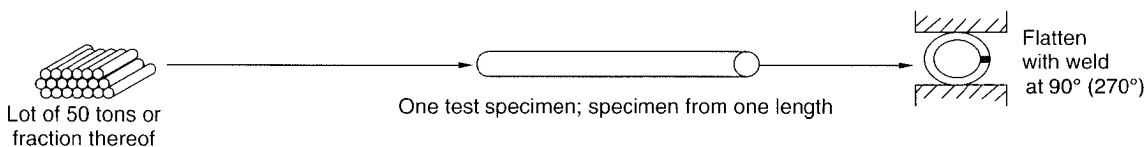

ELECTRIC WELDED PIPE IN GRADES HIGHER THAN A25 AND LASER WELDED PIPE SMALLER THAN SIZE 12³/₄ COLD EXPANDED

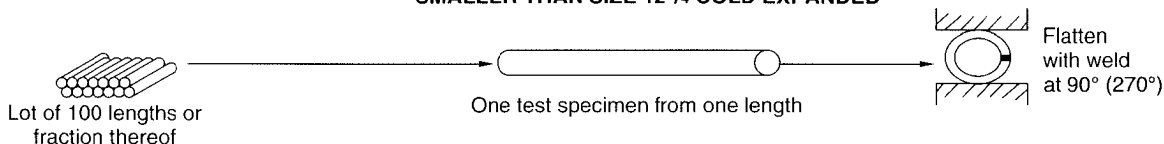

Note: See 9.3.2

04

Figure 5—Flattening Tests

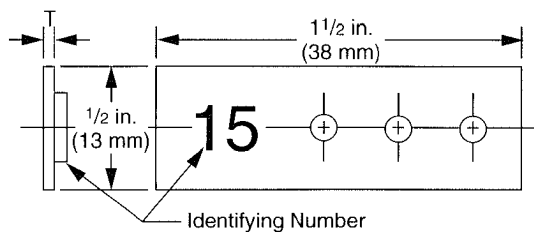

Notes: □

- 1. The diameter of each hole shall be 1/16 in. (1.6 mm). □
- 2. Holes shall be round and drilled perpendicular to the surface. □
- 3. Holes shall be free of burrs, but edges shall not be chamfered. □
- 4. Each penetrator shall carry a lead identification number as given in Tables 14 and 15. □

Figure 6—API Standard Penetrator



Example 1: Two 1/8 in. (3.2 mm) discontinuities

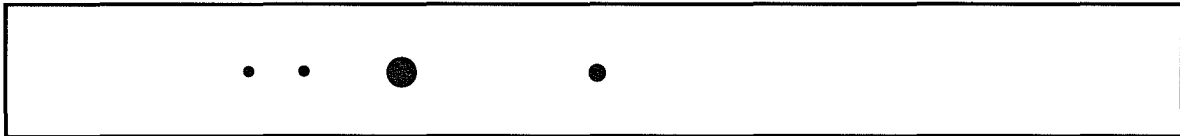

Example 2: One 1/8 in. (3.2 mm), one 1/16 in. (1.6 mm), two 1/32 in. (0.8 mm) discontinuities

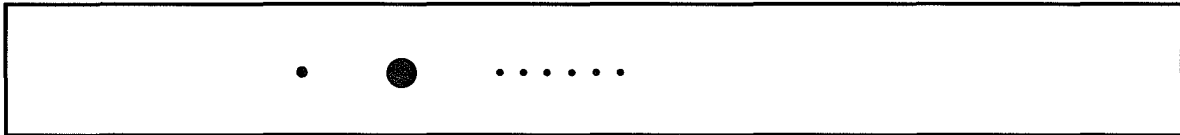

Example 3: One 1/8 in. (3.2 mm), one 1/32 in. (0.8 mm), six 1/64 in. (0.4 mm) discontinuities



Example 4: Four 1/16 in. (1.6 mm) discontinuities

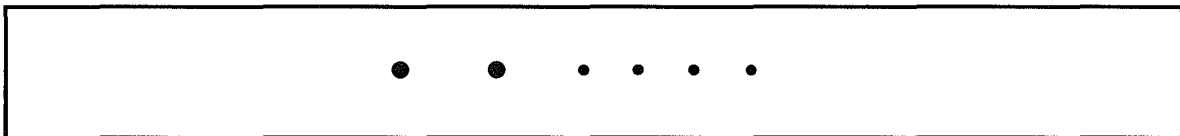

Example 5: Two 1/16 in. (1.6 mm), four 1/32 in. (0.8 mm) discontinuities

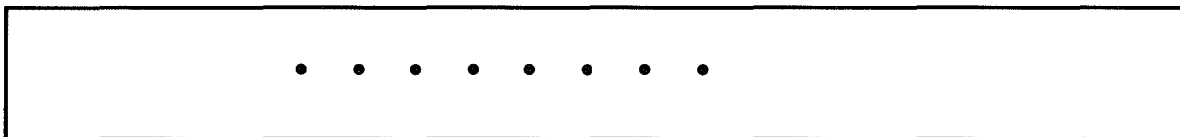

Example 6: Eight 1/32 in. (0.8 mm) discontinuities

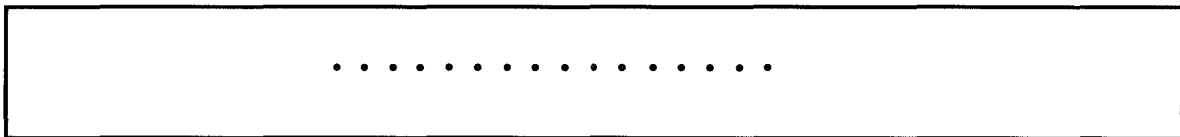

Example 7: Sixteen 1/64 in. (0.4 mm) discontinuities

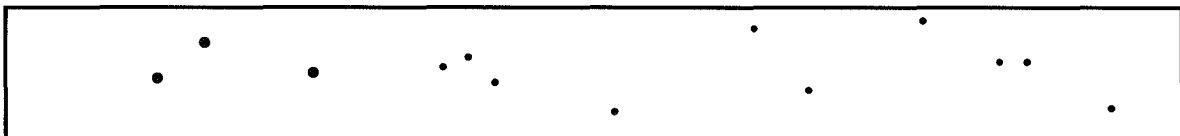

Example 8: Scattered, three 1/32 in. (0.8 mm), ten 1/64 in. (0.4 mm) discontinuities

Figure 7—Examples of Maximum Distribution Patterns of Indicated Circular Slag-inclusion and Gas-pocket-type Discontinuities

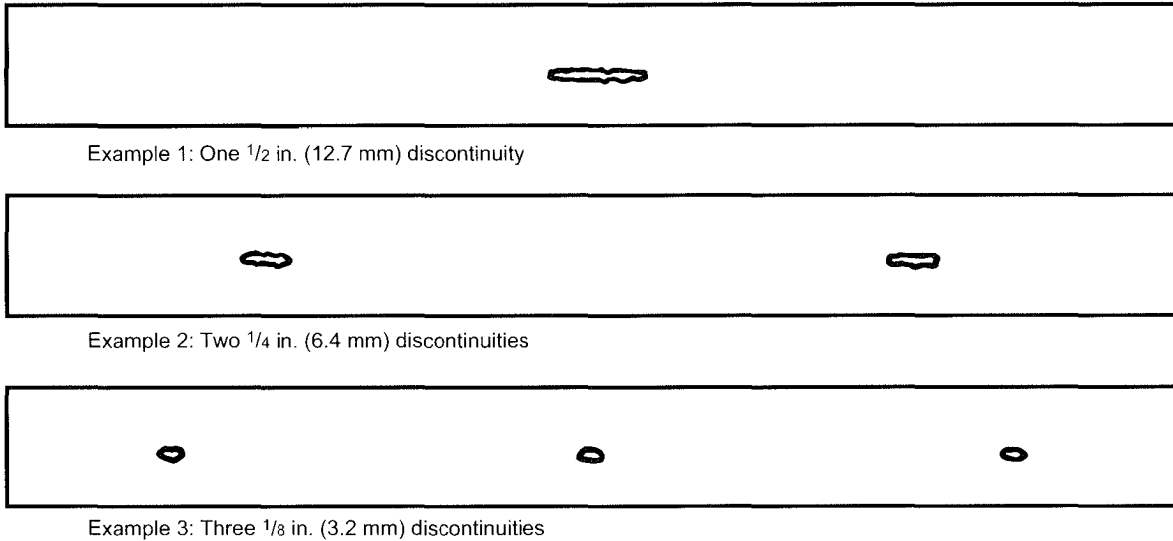
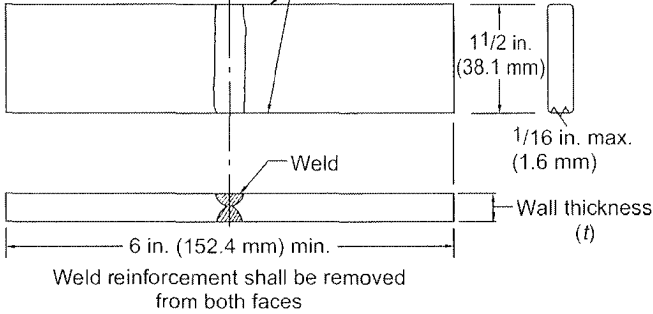

Figure 8—Examples of Maximum Distribution Patterns of Indicated Elongated Slag-inclusion-type Discontinuities

SUBMERGED-ARC AND GAS METAL-ARC WELDED PIPE

LASER WELDED PIPE 12³/₄ AND LARGER

Specimen edges may be oxygen cut and may also be machined



Specimen edges may be oxygen cut and may also be machined

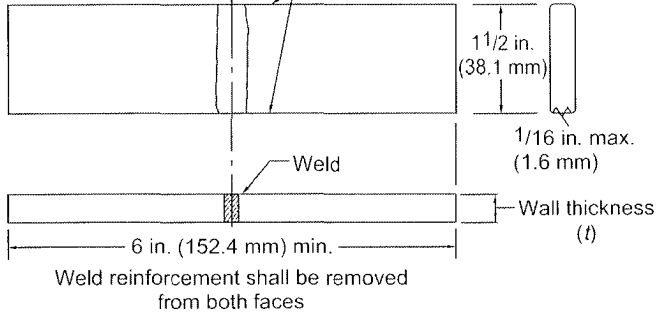

**Reduced Wall Specimens
Optional for Wall Thickness Over 0.750 in. (19.1 mm)**

**Reduced Wall Specimens
Optional for Wall Thickness Over 0.750 in. (19.1 mm)**

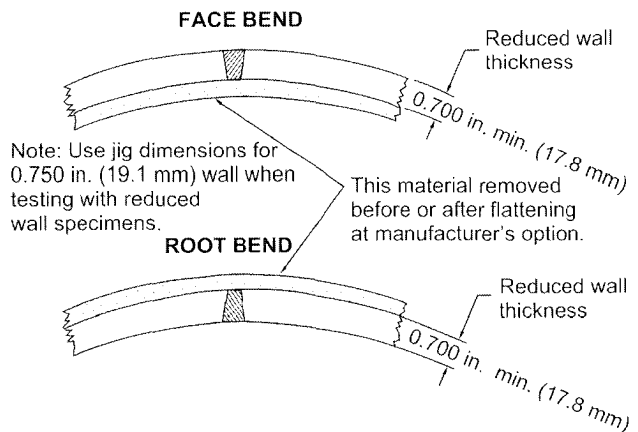
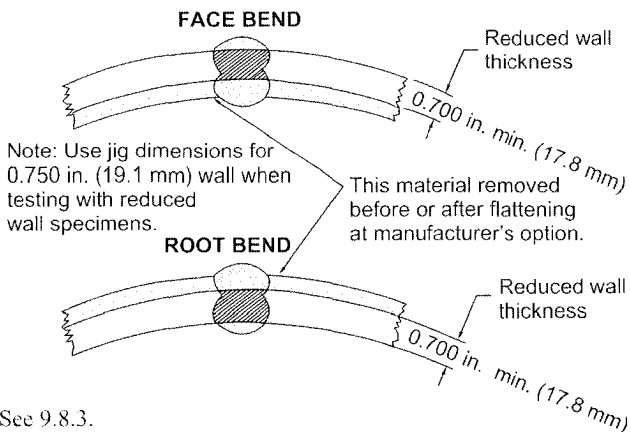

See 9.8.3.

Figure 9—Guided-bend Test Specimen

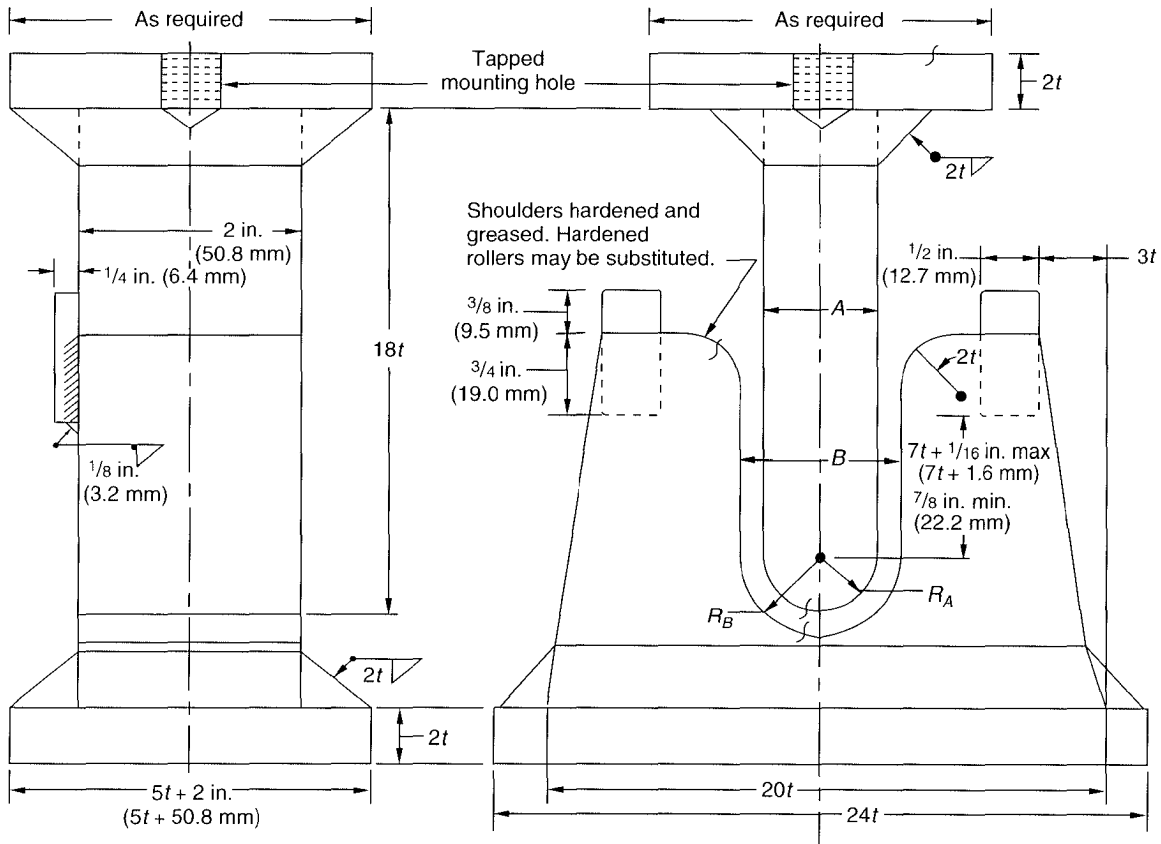

$$A = \frac{1.15(D - 2t) - t}{\left(e \frac{D}{t} - 2e - 1\right)}$$

where

- 1.15 = Peaking factor,
- D = Specified OD, in. (mm),
- t = Specified wall thickness of pipe,
- e = Strain.

	in./in. (mm/mm)
for Grade A =	0.1675
for Grade B =	0.1375
for Grade X42 =	0.1375
for Grade X46 =	0.1325
for Grade X52 =	0.1250
for Grade X56 =	0.1175
for Grade X60 =	0.1125
for Grade X65 =	0.1100
for Grade X70 =	0.1025
for Grade X80 =	0.0900

$$R_A = \frac{1}{2} A$$

$$B \text{ (in.)} = A + 2t + 0.125 \text{ in.}$$

$$B \text{ (mm)} = A + 2t + 3.2 \text{ mm}$$

$$R_B = \frac{1}{2} B$$

Alternate Jigs

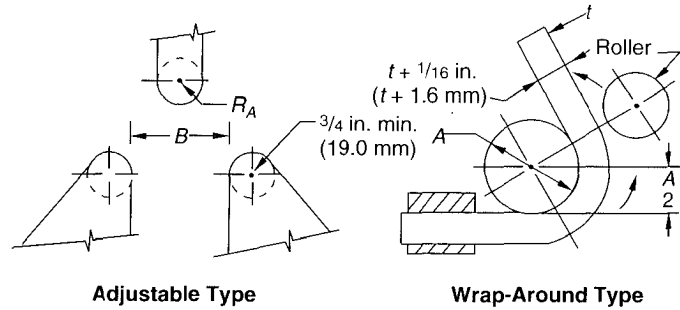

04

04

Note: See 9.10.3

Figure 10—Jig for Guided-bend Test

Table 1—Process of Manufacture and Product Specification Level (PSL)

Process of Manufacture	PSL 1 ^a			PSL 2 ^b
	Grade			Grade
	A25 ^c	A & B	X42 through X70	B through X80
Type of Pipe				
Seamless	X	X	X	X
Welded without Filler Metal				
Continuous welded ^c	X			
Electric welded	X	X	X	X
Laser welded	X	X	X	
Welded with Filler Metal				
Longitudinal seam submerged-arc welded		X	X	X
Gas metal-arc welded		X	X	X
Combination gas metal-arc welded and sub-arc welded		X	X	X
Double seam submerged-arc welded ^d		X	X	X
Double seam gas metal-arc welded ^d		X	X	X
Double seam combination gas metal-arc welded and submerged-arc welded ^d		X	X	X
Helical seam submerged-arc welded ^e		X	X	X
Type of Pipe End				
Belled end ^f	X	X	X	
Plain end	X	X	X	X
Plain end for special coupling	X	X	X	
Threaded end ^g	X	X		

^aPSL 1 is limited to sizes from 0.405 through 80.

^bPSL 2 is limited to sizes from 4¹/₂ through 80.

^cGrade A25, and thus continuous welded pipe (which is limited to A25), is limited to sizes 5⁹/₁₆ and smaller.

^dDouble seam pipe is limited to sizes 36 and larger.

^eHelical seam pipe is limited to sizes 4¹/₂ and larger.

^fBelled end pipe is limited to wall thicknesses of 0.141 in. (3.6 mm) and less; sizes are limited to 8⁵/₈ and smaller.

^gThreaded pipe and couplings are limited to sizes 20 and smaller; helical seam pipe is excluded.

Table 2A—PSL 1 Chemical Requirements for Heat and Product Analyses by Percentage of Weight

(1)	(2)	(3)	(4)		(5)	(6)	(7)
Grade & Class	Carbon, Maximum ^a	Manganese, Maximum ^a	Phosphorus		Sulfur, Maximum	Titanium, Maximum	Other
			Minimum	Maximum			
Seamless							
A25, Cl I	0.21	0.60		0.030	0.030		
A25, Cl II	0.21	0.60	0.045	0.080	0.030		
A	0.22	0.90		0.030	0.030		
B	0.28	1.20		0.030	0.030	0.04	b, c, d
X42	0.28	1.30		0.030	0.030	0.04	c, d
X46, X52, X56	0.28	1.40		0.030	0.030	0.04	c, d
X60 ^f	0.28	1.40		0.030	0.030	0.04	c, d
X65 ^f , X70 ^f	0.28	1.40		0.030	0.030	0.06	c, d
Welded							
A25, Cl I	0.21	0.60		0.030	0.030		
A25, Cl II	0.21	0.60	0.045	0.080	0.030		
A	0.22	0.90		0.030	0.030		
B	0.26	1.20		0.030	0.030	0.04	b, c, d
X42	0.26	1.30		0.030	0.030	0.04	c, d
X46, X52, X56	0.26	1.40		0.030	0.030	0.04	c, d
X60 ^f	0.26	1.40		0.030	0.030	0.04	c, d
X65 ^f	0.26	1.45		0.030	0.030	0.06	c, d
X70 ^f	0.26	1.65		0.030	0.030	0.06	c, d

Table 2B—PSL 2 Chemical Requirements for Heat and Product Analyses by Percentage of Weight

(1)	(2)	(3)	(4)	(5)	(6)	(7)
Grade	Carbon, Maximum ^a	Manganese, Maximum ^a	Phosphorus, Maximum	Sulfur, Maximum	Titanium, Maximum	Other
Seamless						
B	0.24	1.20	0.025	0.015	0.04	c, d, e
X42	0.24	1.30	0.025	0.015	0.04	c, d
X46, X52, X56, X60 ^f	0.24	1.40	0.025	0.015	0.04	c, d
X65 ^f , X70 ^f , X80 ^f	0.24	1.40	0.025	0.015	0.06	c, d
Welded						
B	0.22	1.20	0.025	0.015	0.04	c, d, e
X42	0.22	1.30	0.025	0.015	0.04	c, d
X46, X52, X56	0.22	1.40	0.025	0.015	0.04	c, d
X60 ^f	0.22	1.40	0.025	0.015	0.04	c, d
X65 ^f	0.22	1.45	0.025	0.015	0.06	c, d
X70 ^f	0.22	1.65	0.025	0.015	0.06	c, d
X80 ^f	0.22	1.85	0.025	0.015	0.06	c, d

Footnotes to Tables 2A and 2B:

^aFor each reduction of 0.01% below the specified maximum carbon content, an increase of 0.05% above the specified maximum manganese content is permissible, up to a maximum of 1.50% for Grades X42 through X52, up to a maximum of 1.65% for grades higher than X52 but less than X70, and up to 2.00% for Grades X70 and higher.

^bThe sum of columbium [niobium] and vanadium contents shall not exceed 0.03%, except that, by agreement between the purchaser and the manufacturer, an alternative maximum may be established.

^cColumbium [niobium], vanadium, or combinations thereof may be used at the discretion of the manufacturer.

^dThe sum of the columbium [niobium], vanadium, and titanium contents shall not exceed 0.15%.

^eThe sum of the columbium [niobium], and vanadium contents shall not exceed 0.06% except that, by agreement between the purchaser and the manufacturer, an alternative maximum may be established.

^fOther chemical compositions may be furnished by agreement between purchaser and manufacturer, providing that the limits of footnote d, and the tabular limits for phosphorus and sulfur are met.

Table 3A—Tensile Requirements for PSL 1

(1) Grade	(2)		(3)		(4) Elongation in 2 in. (50.8 mm), Minimum, Percent
	Yield Strength, Minimum		Ultimate Tensile Strength, Minimum		
	psi	MPa	psi	MPa	
A25	25,000	(172)	45,000	(310)	a
A	30,000	(207)	48,000	(331)	a
B	35,000	(241)	60,000	(414)	a
X42	42,000	(290)	60,000	(414)	a
X46	46,000	(317)	63,000	(434)	a
X52	52,000	(359)	66,000	(455)	a
X56	56,000	(386)	71,000	(490)	a
X60	60,000	(414)	75,000	(517)	a
X65	65,000	(448)	77,000	(531)	a
X70	70,000	(483)	82,000	(565)	a

Table 3B—Tensile Requirements for PSL 2

(1) Grade	(2)		(3)		(4)		(5)		(6) Elongation in 2 in. (50.8 mm), Minimum, Percent
	Yield Strength, Minimum		Yield Strength, Maximum ^b		Ultimate Tensile Strength, Minimum		Ultimate Tensile Strength, Maximum ^c		
	psi	MPa	psi	MPa	psi	MPa	psi	MPa	
B	35,000	(241)	65,000 ^d	(448)	60,000	(414)	110,000	(758)	a
X42	42,000	(290)	72,000	(496)	60,000	(414)	110,000	(758)	a
X46	46,000	(317)	76,000	(524)	63,000	(434)	110,000	(758)	a
X52	52,000	(359)	77,000	(531)	66,000	(455)	110,000	(758)	a
X56	56,000	(386)	79,000	(544)	71,000	(490)	110,000	(758)	a
X60	60,000	(414)	82,000	(565)	75,000	(517)	110,000	(758)	a
X65	65,000	(448)	87,000	(600)	77,000	(531)	110,000	(758)	a
X70	70,000	(483)	90,000	(621)	82,000	(565)	110,000	(758)	a
X80	80,000	(552)	100,000 ^e	(690)	90,000	(621)	120,000	(827)	a

Footnotes to Tables 3A and 3B:

^aThe minimum elongation in 2 in. (50.8 mm) shall be that determined by the following equation:

U.S. Customary Unit Equation

$$e = 625,000 \frac{A^{0.2}}{U^{0.9}}$$

SI Unit Equation

$$e = 1,944 \frac{A^{0.2}}{U^{0.9}}$$

where

e = minimum elongation in 2 in. (50.8 mm) in percent rounded to the nearest percent.

A = applicable tensile test specimen area, as follows:

a. For round bar specimens:

— 0.20 in.² (130 mm²) for the 0.500 in. and 0.350 in. specimens,

— 0.10 in.² (65 mm²) for the 0.250 in. specimen.

b. For full section specimens, the smaller of (i) 0.75 in.² (485 mm²) and (ii) the cross-sectional area of the test specimen, calculated using the specified outside diameter of the pipe and the specified wall thickness of the pipe, rounded to the nearest 0.01 in.² (10 mm²);

c. For strip specimens, the smaller of (i) 0.75 in.² (485 mm²) and (ii) the cross-sectional area of the test specimen, calculated using the specified width of the test specimen and the specified wall thickness of the pipe, rounded to the nearest 0.01 in.² (10 mm²).

U = specified minimum ultimate tensile strength in psi (MPa).

See Appendix D for the specified minimum elongation values for various tensile specimen sizes and grades.

^bMaximum yield strength for an intermediate grade shall be the maximum for the next higher listed grade.

^cAll intermediate grades have a maximum ultimate tensile strength of 110,000 psi (758 MPa).

^dMaximum yield strength for Grade B pipe in sizes subject to longitudinal testing is 72,000 psi (496 MPa).

^eFor wall thickness greater than 0.984 in. (25.0 mm), the maximum yield strength shall be determined by agreement between the purchaser and the manufacturer.

Table 4—Standard-wall Threaded Line Pipe Dimensions, Weights, and Test Pressures
(U.S. Customary and SI Units)

(1)	(2)		(3)		(4)		(5)		(6)		(7)		(8)		(9)	
Size	Specified Outside Diameter D		Specified Wall Thickness t		Calculated Weight				Calculated Inside Diameter ^b d		Minimum Test Pressure					
	in.	mm	in.	mm	Plain-end Weight per Unit Length w_{pe}		Threads and Couplings ^d e_w		in.	mm	Grade A25		Grade A		Grade B	
					lb/ft	kg/m	lb	kg			psi	100 kPa ^c	psi	100 kPa ^c	psi	100 kPa ^c
0.405	0.405	10.3	0.068	1.7	0.24	0.36	0.20	0.09	0.269	6.9	700	48	700	48	700	48
0.540	0.540	13.7	0.088	2.2	0.43	0.62	0.20	0.09	0.364	9.3	700	48	700	48	700	48
0.675	0.675	17.1	0.091	2.3	0.57	0.84	0.20	0.09	0.493	12.5	700	48	700	48	700	48
0.840	0.840	21.3	0.109	2.8	0.85	1.28	0.20	0.09	0.622	15.7	700	48	700	48	700	48
1.050	1.050	26.7	0.113	2.9	1.13	1.70	0.20	0.09	0.824	20.9	700	48	700	48	700	48
1.315	1.315	33.4	0.133	3.4	1.68	2.52	0.20	0.09	1.049	26.6	700	48	700	48	700	48
1.660	1.660	42.2	0.140	3.6	2.27	3.43	0.60	0.27	1.380	35.0	1000	69	1000	69	1100	76
1.900	1.900	48.3	0.145	3.7	2.72	4.07	0.40	0.18	1.610	40.9	1000	69	1000	69	1100	76
2 ³ / ₈	2.375	60.3	0.154	3.9	3.66	5.42	1.20	0.54	2.067	52.5	1000	69	1000	69	1100	76
2 ⁷ / ₈	2.875	73.0	0.203	5.2	5.80	8.69	1.80	0.82	2.469	62.6	1000	69	1000	69	1100	76
3 ¹ / ₂	3.500	88.9	0.216	5.5	7.58	11.31	1.80	0.82	3.068	77.9	1000	69	1000	69	1100	76
4	4.000	101.6	0.226	5.7	9.12	13.48	3.20	1.45	3.548	90.2	1200	83	1200	83	1300	90
4 ¹ / ₂	4.500	114.3	0.237	6.0	10.80	16.02	4.40	2.00	4.026	102.3	1200	83	1200	83	1300	90
5 ⁹ / ₁₆	5.563	141.3	0.258	6.6	14.63	21.92	5.60	2.54	5.047	128.1	1200	83	1200	83	1300	90
6 ⁵ / ₈	6.625	168.3	0.280	7.1	18.99	28.22	7.20	3.27	6.065	154.1	—	—	1200	83	1300	90
8 ⁵ / ₈	8.625	219.1	0.277	7.0	24.72	36.61	14.80	6.72	8.071	205.1	—	—	1160	79	1350	92
8 ⁵ / ₈	8.625	219.1	0.322	8.2	28.58	42.65	14.00	6.36	7.981	202.7	—	—	1340	93	1570	108
10 ³ / ₄	10.750	273.1	0.279	7.1	31.23	46.57	20.00	9.08	10.192	258.9	—	—	930	65	1090	75
10 ³ / ₄	10.750	273.1	0.307	7.8	34.27	51.03	19.20	8.72	10.136	257.5	—	—	1030	71	1200	83
10 ³ / ₄	10.750	273.1	0.365	9.3	40.52	60.50	17.40	7.90	10.020	254.5	—	—	1220	85	1430	98
12 ³ / ₄	12.750	323.9	0.330	8.4	43.81	65.35	32.60	14.80	12.090	307.1	—	—	930	64	1090	75
12 ³ / ₄	12.750	323.9	0.375	9.5	49.61	73.65	30.80	13.98	12.000	304.9	—	—	1060	73	1240	85
14	14.000	355.6	0.375	9.5	54.62	81.08	24.60	11.17	13.250	336.6	—	—	960	66	1130	77
16	16.000	406.4	0.375	9.5	62.64	92.98	30.00	13.62	15.250	387.4	—	—	840	58	980	68
18	18.000	457.0	0.375	9.5	70.65	104.84	35.60	16.16	17.250	438.0	—	—	750	52	880	60
20	20.000	508.0	0.375	9.5	78.67	116.78	42.00	19.07	19.250	489.0	—	—	680	46	790	54

Note: See Figure 2.

^aWeight gain due to end finishing. See 7.4.

^bThe calculated inside diameters are given here for information (see 7.2).

^c100 kPa = 1 bar

Table 5—Heavy-wall Threaded Line Pipe Dimensions, Weights, and Test Pressures
(U.S. Customary and SI Units)

(1) Size	(2) Specified Outside Diameter <i>D</i>		(3) Specified Wall Thickness <i>t</i>		(4) Calculated Weight				(6) Calculated Inside Diameter ^b <i>d</i>		(7) Minimum Test Pressure					
	in.	mm	in.	mm	(4) Plain-End Weight per Unit Length <i>w_{pe}</i>		(5) Threads and Coupling ^a <i>e_w</i>		in.	mm	(7) Grade A25		(8) Grade A		(9) Grade B	
					lb/ft	kg/m	lb	kg			psi	100 kPa ^c	psi	100 kPa ^c	psi	100 kPa ^c
0.405	0.405	10.3	0.095	2.4	0.31	0.47	0.02	0.01	0.215	5.5	850	59	850	59	850	59
0.540	0.540	13.7	0.119	3.0	0.54	0.79	0.05	0.02	0.302	7.7	850	59	850	59	850	59
0.675	0.675	17.1	0.126	3.2	0.74	1.10	0.07	0.03	0.423	10.7	850	59	850	59	850	59
0.840	0.840	21.3	0.147	3.7	1.09	1.61	0.12	0.05	0.546	13.9	850	59	850	59	850	59
1.050	1.050	26.7	0.154	3.9	1.48	2.19	0.18	0.08	0.742	18.9	850	59	850	59	850	59
1.315	1.315	33.4	0.179	4.5	2.17	3.21	0.23	0.10	0.957	24.4	850	59	850	59	850	59
1.660	1.660	42.2	0.191	4.9	3.00	4.51	0.58	0.56	1.278	32.4	1300	90	1500	103	1600	110
1.900	1.900	48.3	0.200	5.1	3.63	5.43	0.36	0.16	1.500	38.1	1300	90	1500	103	1600	110
2 ³ / ₈	2.375	60.3	0.218	5.5	5.03	7.43	1.09	0.50	1.939	49.3	1300	90	2500	172	2500	172
2 ⁷ / ₈	2.875	73.0	0.276	7.0	7.67	11.39	1.57	0.71	2.323	59.0	1300	90	2500	172	2500	172
3 ¹ / ₂	3.500	88.9	0.300	7.6	10.26	15.24	1.76	0.80	2.900	73.7	1300	90	2500	172	2500	172
4	4.000	101.6	0.318	8.1	12.52	18.68	3.00	1.36	3.364	85.4	1700	117	2800	193	2800	193
4 ¹ / ₂	4.500	114.3	0.337	8.6	15.00	22.42	3.99	1.81	3.826	97.1	1700	117	2700	187	2800	193
5 ⁹ / ₁₆	5.563	141.3	0.375	9.5	20.80	30.88	4.94	2.24	4.813	122.3	1700	117	2430	167	2800	193
6 ⁵ / ₈	6.625	168.3	0.432	11.0	28.60	42.67	5.65	2.56	5.761	146.3	—	—	2350	162	2740	189
8 ⁵ / ₈	8.625	219.1	0.500	12.7	43.43	64.64	11.47	5.20	7.625	193.7	—	—	2090	144	2430	168
10 ³ / ₄	10.750	273.1	0.500	12.7	54.79	81.55	15.32	6.95	9.750	247.7	—	—	1670	116	1950	134
12 ³ / ₄	12.750	323.9	0.500	12.7	65.48	97.46	28.74	13.04	11.750	298.5	—	—	1410	97	1650	113

^aWeight gain due to end finishing (see 7.4).

^bThe calculated inside diameters are given here for information (see 7.2).

^c100 kPa = 1 bar

Table 6A—Plain-end Line Pipe Dimensions, Weights per Unit Length, and Test Pressures for Sizes 0.405 Through 1.900 (U.S. Customary Units)

(1) Size	(2) Specified Outside Diameter <i>D</i> (in.)	(3) Specified Wall Thickness <i>t</i> (in.)	(4) Plain-end Weight per Unit Length <i>w_{pe}</i> (lb/ft)	(5) Calculated Inside Diameter ^a <i>d</i> (in.)	(6) Grade A25	(7)–(10) Minimum Test Pressure (psi) ^b			
						Grade A		Grade B	
						Std.	Alt.	Std.	Alt.
0.405	0.405	0.068	0.24	0.269	700	700	—	700	—
0.405	0.405	0.095	0.31	0.215	850	850	—	850	—
0.540	0.540	0.088	0.43	0.364	700	700	—	700	—
0.540	0.540	0.119	0.54	0.302	850	850	—	850	—
0.675	0.675	0.091	0.57	0.493	700	700	—	700	—
0.675	0.675	0.126	0.74	0.423	850	850	—	850	—
0.840	0.840	0.109	0.85	0.622	700	700	—	700	—
0.840	0.840	0.147	1.09	0.546	850	850	—	850	—
0.840	0.840	0.294	1.72	0.252	1000	1000	—	1000	—
1.050	1.050	0.113	1.13	0.824	700	700	—	700	—
1.050	1.050	0.154	1.48	0.742	850	850	—	850	—
1.050	1.050	0.308	2.44	0.434	1000	1000	—	1000	—
1.315	1.315	0.133	1.68	1.049	700	700	—	700	—
1.315	1.315	0.179	2.17	0.957	850	850	—	850	—
1.315	1.315	0.358	3.66	0.599	1000	1000	—	1000	—
1.660	1.660	0.140	2.27	1.380	1000	1200	—	1300	—
1.660	1.660	0.191	3.00	1.278	1300	1800	—	1900	—
1.660	1.660	0.382	5.22	0.896	1400	2200	—	2300	—
1.900	1.900	0.145	2.72	1.610	1000	1200	—	1300	—
1.900	1.900	0.200	3.63	1.500	1300	1800	—	1900	—
1.900	1.900	0.400	6.41	1.100	1400	2200	—	2300	—

Note: See Table E-6A for SI unit values corresponding to the U.S. Customary unit values given in this table.

^aThe calculated inside diameters are given here for information (see 7.2).

^bThe test pressures given in Tables 6A, 6B, and 6C apply to Grades A25, A, B, X42, X46, X52, X56, X60, X65, X70, and X80 only. See 9.4.3 for pressures applicable to other grades.

Table 6B — Plain-end Line Pipe Dimensions, Weights per Unit Length, and Test Pressures for Sizes 2³/₈ through 5⁹/₁₆ (U.S. Customary Units)

(1) Size	(2) Specified Outside Diameter <i>D</i> (in.)	(3) Specified Wall Thickness <i>t</i> (in.)	(4) Plain-end Weight per Unit Length <i>w_{pe}</i> (lb/ft)	(5) Calculated Inside Diameter ^a <i>d</i> (in.)	(6) through (16) Minimum Test Pressure (psi) ^b											
					Grade A25	Grade A	Grade B	Grade X42	Grade X46	Grade X52	Grade X56	Grade X60	Grade X65	Grade X70	Grade X80	
					Std.	Alt.	Std.	Alt.	Std.	Alt.	Std.	Alt.	Std.	Alt.	Std.	Alt.
2 ³ / ₈ ^c	2.375	0.083	2.03	2.209	Std.	600	1260	1470	1760	1930	2180	2350	2520	2730	2940	—
					Alt.	—	1570	1830	2200	2410	2730	2940	3150	3410	3670	—
2 ³ / ₈ ^c	2.375	0.109	2.64	2.157	Std.	800	1650	1930	2310	2530	2860	3000	3000	3000	3000	—
					Alt.	—	2070	2410	2890	3170	3580	3860	4130	4470	4820	—
2 ³ / ₈ ^c	2.375	0.125	3.01	2.125	Std.	1000	1890	2210	2650	2910	3000	3000	3000	3000	3000	—
					Alt.	—	2370	2500	3320	3630	4110	4420	4740	5130	5530	—
2 ³ / ₈ ^c	2.375	0.141	3.37	2.093	Std.	1000	2140	2490	2990	3000	3000	3000	3000	3000	3000	—
					Alt.	—	2500	2500	3740	4100	4630	4990	5340	5790	6230	—
2 ³ / ₈	2.375	0.154	3.66	2.067	Std.	1000	2330	2500	3000	3000	3000	3000	3000	3000	3000	—
					Alt.	—	2500	2500	4090	4470	5060	5450	5840	6320	6810	—
2 ³ / ₈	2.375	0.172	4.05	2.031	Std.	1100	2500	2500	3000	3000	3000	3000	3000	3000	3000	—
					Alt.	—	2500	2500	4560	5000	5650	6080	6520	7060	7260	—
2 ³ / ₈	2.375	0.188	4.40	1.999	Std.	1200	2500	2500	3000	3000	3000	3000	3000	3000	3000	—
					Alt.	—	2500	2500	4990	5460	6170	6650	7120	7260	7260	—
2 ³ / ₈	2.375	0.218	5.03	1.939	Std.	1300	2500	2500	3000	3000	3000	3000	3000	3000	3000	—
					Alt.	—	2500	2500	5780	6330	7160	7260	7260	7260	7260	—
2 ³ / ₈	2.375	0.250	5.68	1.875	Std.	1400	2500	2500	3000	3000	3000	3000	3000	3000	3000	—
					Alt.	—	2500	2500	6630	7260	7260	7260	7260	7260	7260	—
2 ³ / ₈	2.375	0.281	6.29	1.813	Std.	1400	2500	2500	3000	3000	3000	3000	3000	3000	3000	—
					Alt.	—	2500	2500	7260	7260	7260	7260	7260	7260	7260	—
2 ³ / ₈	2.375	0.436	9.04	1.503	Std.	1400	2500	2500	3000	3000	3000	3000	3000	3000	3000	—
					Alt.	—	2500	2500	7260	7260	7260	7260	7260	7260	7260	—
2 ⁷ / ₈ ^c	2.875	0.083	2.48	2.709	Std.	600	1040	1210	1460	1590	1800	1940	2080	2250	2430	—
					Alt.	—	1300	1520	1820	1990	2250	2430	2600	2810	3030	—
2 ⁷ / ₈ ^c	2.875	0.109	3.22	2.657	Std.	800	1360	1590	1910	2090	2370	2550	2730	2960	3000	—
					Alt.	—	1710	1990	2390	2620	2960	3180	3410	3700	3980	—
2 ⁷ / ₈ ^c	2.875	0.125	3.67	2.625	Std.	1000	1570	1830	2190	2400	2710	2920	3000	3000	3000	—
					Alt.	—	1960	2280	2740	3000	3390	3650	3910	4240	4570	—
2 ⁷ / ₈ ^c	2.875	0.141	4.12	2.593	Std.	1000	1770	2060	2470	2710	3000	3000	3000	3000	3000	—
					Alt.	—	2210	2500	3090	3380	3830	4120	4410	4780	5150	—
2 ⁷ / ₈	2.875	0.156	4.53	2.563	Std.	1000	1950	2280	2730	3000	3000	3000	3000	3000	3000	—
					Alt.	—	2440	2500	3420	3740	4230	4560	4880	5290	5700	—
2 ⁷ / ₈	2.875	0.172	4.97	2.531	Std.	1000	2150	2500	3000	3000	3000	3000	3000	3000	3000	—
					Alt.	—	2500	2500	3770	4130	4670	5030	5380	5830	6280	—
2 ⁷ / ₈	2.875	0.188	5.40	2.499	Std.	1000	2350	2500	3000	3000	3000	3000	3000	3000	3000	—
					Alt.	—	2500	2500	4120	4510	5100	5490	5890	6380	6870	—
2 ⁷ / ₈	2.875	0.203	5.80	2.469	Std.	1000	2500	2500	3000	3000	3000	3000	3000	3000	3000	—
					Alt.	—	2500	2500	4450	4870	5510	5930	6350	6880	7260	—
2 ⁷ / ₈	2.875	0.216	6.14	2.443	Std.	1100	2500	2500	3000	3000	3000	3000	3000	3000	3000	—
					Alt.	—	2500	2500	4730	5180	5860	6310	6760	7260	7260	—
2 ⁷ / ₈	2.875	0.250	7.02	2.375	Std.	1200	2500	2500	3000	3000	3000	3000	3000	3000	3000	—
					Alt.	—	2500	2500	5480	6000	6780	7260	7260	7260	7260	—
2 ⁷ / ₈	2.875	0.276	7.67	2.323	Std.	1300	2500	2500	3000	3000	3000	3000	3000	3000	3000	—
					Alt.	—	2500	2500	6050	6620	7260	7260	7260	7260	7260	—
2 ⁷ / ₈	2.875	0.552	13.71	1.771	Std.	1400	2500	2500	3000	3000	3000	3000	3000	3000	3000	—
					Alt.	—	2500	2500	7260	7260	7260	7260	7260	7260	7260	—
3 ¹ / ₂ ^c	3.500	0.083	3.03	3.334	Std.	600	850	1000	1200	1310	1480	1590	1710	1850	1990	—
					Alt.	—	1070	1250	1490	1640	1850	1990	2130	2310	2490	—
3 ¹ / ₂ ^c	3.500	0.109	3.95	3.282	Std.	800	1120	1310	1570	1720	1940	2090	2240	2430	2620	—
					Alt.	—	1400	1640	1960	2150	2430	2620	2800	3040	3270	—

Table 6B (Continued)—Plain-end Line Pipe Dimensions, Weights per Unit Length, and Test Pressures for Sizes 2³/₈ through 5⁹/₁₆ (U.S. Customary Units)

(1)	(2)	(3)	(4)	(5)	(6)	(7)	(8)	(9)	(10)	(11)	(12)	(13)	(14)	(15)	(16)	
Size	Specified Outside Diameter <i>D</i> (in.)	Specified Wall Thickness <i>t</i> (in.)	Plain-end Weight per Unit Length <i>w_{pe}</i> (lb/ft)	Calculated Inside Diameter ^a <i>d</i> (in.)	Minimum Test Pressure (psi) ^b											
					Grade A25	Grade A	Grade B	Grade X42	Grade X46	Grade X52	Grade X56	Grade X60	Grade X65	Grade X70	Grade X80	
3 ¹ / ₂ ^c	3.500	0.125	4.51	3.250	Std.	1000	1290	1500	1800	1970	2230	2400	2570	2790	3000	—
					Alt.	—	1610	1880	2250	2460	2790	3000	3210	3480	3750	—
3 ¹ / ₂ ^c	3.500	0.141	5.06	3.218	Std.	1000	1450	1690	2030	2220	2510	2710	2900	3000	3000	—
					Alt.	—	1810	2120	2540	2780	3140	3380	3630	3930	4230	—
3 ¹ / ₂ ^c	3.500	0.156	5.58	3.188	Std.	1000	1600	1870	2250	2460	2780	3000	3000	3000	3000	—
					Alt.	—	2010	2340	2810	3080	3480	3740	4010	4350	4680	—
3 ¹ / ₂	3.500	0.172	6.12	3.156	Std.	1000	1770	2060	2480	2710	3000	3000	3000	3000	3000	—
					Alt.	—	2210	2500	3100	3390	3830	4130	4420	4790	5160	—
3 ¹ / ₂	3.500	0.188	6.66	3.124	Std.	1000	1930	2260	2710	2970	3000	3000	3000	3000	3000	—
					Alt.	—	2420	2500	3380	3710	4190	4510	4830	5240	5640	—
3 ¹ / ₂	3.500	0.216	7.58	3.068	Std.	1000	2220	2500	3000	3000	3000	3000	3000	3000	3000	—
					Alt.	—	2500	2500	3890	4260	4810	5180	5550	6020	6480	—
3 ¹ / ₂	3.500	0.250	8.69	3.000	Std.	—	2500	2500	3000	3000	3000	3000	3000	3000	3000	—
					Alt.	—	2500	2500	4500	4930	5570	6000	6430	6960	7260	—
3 ¹ / ₂	3.500	0.281	9.67	2.938	Std.	—	2500	2500	3000	3000	3000	3000	3000	3000	3000	—
					Alt.	—	2500	2500	5060	5540	6260	6740	7230	7260	7260	—
3 ¹ / ₂	3.500	0.300	10.26	2.900	Std.	1300	2500	2500	3000	3000	3000	3000	3000	3000	3000	—
					Alt.	—	2500	2500	5400	5910	6690	7200	7260	7260	7260	—
3 ¹ / ₂	3.500	0.600	18.60	2.300	Std.	—	2500	2500	3000	3000	3000	3000	3000	3000	3000	—
					Alt.	—	2500	2500	7260	7260	7260	7260	7260	7260	7260	—
4 ^c	4.000	0.083	3.48	3.834	Std.	—	750	870	1050	1150	1290	1390	1490	1620	1740	—
					Alt.	—	930	1090	1310	1430	1620	1740	1870	2020	2180	—
4 ^c	4.000	0.109	4.53	3.782	Std.	600	980	1140	1370	1500	1700	1830	1960	2130	2290	—
					Alt.	—	1230	1430	1720	1880	2130	2290	2450	2660	2860	—
4 ^c	4.000	0.125	5.18	3.750	Std.	—	1130	1310	1580	1730	1950	2100	2250	2440	2630	—
					Alt.	—	1410	1640	1970	2160	2440	2630	2810	3050	3280	—
4 ^c	4.000	0.141	5.82	3.718	Std.	800	1270	1480	1780	1950	2200	2370	2540	2750	2960	—
					Alt.	—	1590	1850	2220	2430	2750	2960	3170	3440	3700	—
4 ^c	4.000	0.156	6.41	3.688	Std.	—	1400	1640	1970	2150	2430	2620	2810	3000	3000	—
					Alt.	—	1760	2050	2460	2690	3040	3280	3510	3800	4100	—
4	4.000	0.172	7.04	3.656	Std.	1000	1550	1810	2170	2370	2680	2890	3000	3000	3000	—
					Alt.	—	1940	2260	2710	2970	3350	3610	3870	4190	4520	—
4	4.000	0.188	7.66	3.624	Std.	1200	1690	1970	2370	2590	2930	3000	3000	3000	3000	—
					Alt.	—	2120	2470	2960	3240	3670	3950	4230	4580	4940	—
4	4.000	0.226	9.12	3.548	Std.	1200	2030	2370	2850	3000	3000	3000	3000	3000	3000	—
					Alt.	—	2540	2800	3560	3900	4410	4750	5090	5510	5930	—
4	4.000	0.250	10.02	3.500	Std.	—	2250	2630	3000	3000	3000	3000	3000	3000	3000	—
					Alt.	—	2800	2800	3940	4310	4880	5250	5630	6090	6560	—
4	4.000	0.281	11.17	3.438	Std.	—	2530	2800	3000	3000	3000	3000	3000	3000	3000	—
					Alt.	—	2800	2800	4430	4850	5480	5900	6320	6850	7260	—
4	4.000	0.318	12.52	3.364	Std.	1700	2800	2800	3000	3000	3000	3000	3000	3000	3000	—
					Alt.	—	2800	2800	5010	5490	6200	6680	7160	7260	7260	—
4 ¹ / ₂ ^c	4.500	0.083	3.92	4.334	Std.	—	660	770	930	1020	1150	1240	1330	1440	1550	1770
					Alt.	—	830	970	1160	1270	1440	1550	1660	1800	1940	2210
4 ¹ / ₂ ^c	4.500	0.125	5.85	4.250	Std.	800	1000	1170	1400	1530	1730	1870	2000	2170	2330	2670
					Alt.	—	1250	1460	1750	1920	2170	2330	2500	2710	2920	3330
4 ¹ / ₂ ^c	4.500	0.141	6.57	4.218	Std.	—	1130	1320	1580	1730	1960	2110	2260	2440	2630	3000
					Alt.	—	1410	1650	1970	2160	2440	2630	2820	3060	3290	3760
4 ¹ / ₂ ^c	4.500	0.156	7.24	4.188	Std.	1000	1250	1460	1750	1910	2160	2330	2500	2700	2910	3000
					Alt.	—	1560	1820	2180	2390	2700	2910	3120	3380	3640	4160

Table 6B (Continued)—Plain-end Line Pipe Dimensions, Weights per Unit Length, and Test Pressures for Sizes 2³/₈ through 5⁹/₁₆ (U.S. Customary Units)

(1)	(2)	(3)	(4)	(5)	(6)	(7)	(8)	(9)	(10)	(11)	(12)	(13)	(14)	(15)	(16)
Size	Specified Outside Diameter	Specified Wall Thickness	Plain-end Weight per Unit Length	Calculated Inside Diameter ^a	Minimum Test Pressure (psi) ^b										
	<i>D</i> (in.)	<i>t</i> (in.)	<i>w_{pe}</i> (lb/ft)	<i>d</i> (in.)	Grade A25	Grade A	Grade B	Grade X42	Grade X46	Grade X52	Grade X56	Grade X60	Grade X65	Grade X70	Grade X80
5 ⁹ / ₁₆	5.563	0.750	38.59	4.063	Std.	2800	2800	2800	3000	3000	3000	3000	3000	3000	3000
					Alt.	—	2800	2800	7260	7260	7260	7260	7260	7260	7260

Note: See Table E-6B for SI unit values corresponding to the U.S. Customary unit values given in this table.

^aThe calculated inside diameters are given here for information (see 7.2).

^bThe test pressures given in Tables 6A, 6B, and 6C apply to Grades A25, A, B, X42, X46, X52, X56, X60, X65, X70, and X80 only. See 9.4.3 for pressures applicable to other grades.

^cPipe that has this combination of specified outside diameter and specified wall thickness is special plain-end pipe; other combinations given in this table are regular plain-end pipe. Pipe that has a combination of specified outside diameter and specified wall thickness that is intermediate to the tabulated values is considered to be special plain-end pipe if the next lower tabulated value is for special plain-end pipe; other intermediate combinations are considered to be regular plain-end pipe. (See Table 10 for the applicable weight tolerances.)

Table 6C —Plain-end Line Pipe Dimensions, Weights per Unit Length, and Test Pressures for Sizes 6⁵/₈ through 80 (U.S. Customary Units)

(1)	(2)	(3)	(4)	(5)	(6)	(7)	(8)	(9)	(10)	(11)	(12)	(13)	(14)	(15)
Size	Specified Outside Diameter	Specified Wall Thickness	Plain-end Weight per Unit Length	Calculated Inside Diameter ^a	Minimum Test Pressure (psi) ^b									
	<i>D</i> (in.)	<i>t</i> (in.)	<i>w_{pe}</i> (lb/ft)	<i>d</i> (in.)	Grade A	Grade B	Grade X42	Grade X46	Grade X52	Grade X56	Grade X60	Grade X65	Grade X70	Grade X80
6 ⁵ / ₈ ^c	6.625	0.083	5.80	6.459	Std.	450	530	790	860	980	1050	1130	1320	1500
					Alt.	560	660	790	860	980	1050	1130	1220	1320
6 ⁵ / ₈ ^c	6.625	0.109	7.59	6.407	Std.	590	690	1040	1140	1280	1380	1480	1600	1730
					Alt.	740	860	1040	1140	1280	1380	1480	1600	1730
6 ⁵ / ₈ ^c	6.625	0.125	8.69	6.375	Std.	680	790	1190	1300	1470	1580	1700	1840	1980
					Alt.	850	990	1190	1300	1470	1580	1700	1840	1980
6 ⁵ / ₈ ^c	6.625	0.141	9.77	6.343	Std.	770	890	1340	1470	1660	1790	1920	2080	2230
					Alt.	960	1120	1340	1470	1660	1790	1920	2080	2230
6 ⁵ / ₈ ^c	6.625	0.156	10.79	6.313	Std.	850	990	1480	1620	1840	1980	2120	2300	2470
					Alt.	1060	1240	1480	1620	1840	1980	2120	2300	2470
6 ⁵ / ₈	6.625	0.172	11.87	6.281	Std.	930	1090	1640	1790	2030	2180	2340	2530	2730
					Alt.	1170	1360	1640	1790	2030	2180	2340	2530	2730
6 ⁵ / ₈	6.625	0.188	12.94	6.249	Std.	1020	1190	1790	1960	2210	2380	2550	2770	2980
					Alt.	1280	1490	1790	1960	2210	2380	2550	2770	2980
6 ⁵ / ₈	6.625	0.203	13.94	6.219	Std.	1100	1290	1930	2110	2390	2570	2760	2990	3000
					Alt.	1380	1610	1930	2110	2390	2570	2760	2990	3220
6 ⁵ / ₈	6.625	0.219	15.00	6.187	Std.	1190	1390	2080	2280	2580	2780	2980	3000	3000
					Alt.	1490	1740	2080	2280	2580	2780	2980	3220	3470
6 ⁵ / ₈	6.625	0.250	17.04	6.125	Std.	1360	1580	2380	2600	2940	3000	3000	3000	3000
					Alt.	1700	1980	2380	2600	2940	3170	3400	3680	3960
6 ⁵ / ₈	6.625	0.280	18.99	6.065	Std.	1520	1780	2660	2920	3000	3000	3000	3000	3000
					Alt.	1900	2220	2660	2920	3300	3550	3800	4120	4440
6 ⁵ / ₈	6.625	0.312	21.06	6.001	Std.	1700	1980	2970	3000	3000	3000	3000	3000	3000
					Alt.	2120	2470	2970	3250	3670	3960	4240	4590	4940
6 ⁵ / ₈	6.625	0.344	23.10	5.937	Std.	1870	2180	3000	3000	3000	3000	3000	3000	3000
					Alt.	2340	2730	3270	3580	4050	4360	4670	5060	5450
6 ⁵ / ₈	6.625	0.375	25.05	5.875	Std.	2040	2380	3000	3000	3000	3000	3000	3000	3000
					Alt.	2550	2800	3570	3910	4420	4750	5090	5520	5940
6 ⁵ / ₈	6.625	0.432	28.60	5.761	Std.	2350	2740	3000	3000	3000	3000	3000	3000	3000
					Alt.	2800	2800	4110	4500	5090	5480	5870	6360	6850
6 ⁵ / ₈	6.625	0.500	32.74	5.625	Std.	2720	2800	3000	3000	3000	3000	3000	3000	3000
					Alt.	2800	2800	4750	5210	5890	6340	6790	7260	7260

Table 6C (Continued)—Plain-end Line Pipe Dimensions, Weights per Unit Length, and Test Pressures for Sizes 6⁵/₈ through 80 (U.S. Customary Units)

(1)	(2)	(3)	(4)	(5)	(6)	(7)	(8)	(9)	(10)	(11)	(12)	(13)	(14)	(15)
Size	Specified Outside Diameter <i>D</i> (in.)	Specified Wall Thickness <i>t</i> (in.)	Plain-end Weight per Unit Length <i>w_{pe}</i> (lb/ft)	Calculated Inside Diameter ^a <i>d</i> (in.)	Minimum Test Pressure (psi) ^b									
					Grade A	Grade B	Grade X42	Grade X46	Grade X52	Grade X56	Grade X60	Grade X65	Grade X70	Grade X80
8 ⁵ / ₈	8.625	1.000	81.51	6.625	Std.	2800	2800	3000	3000	3000	3000	3000	3000	3000
					Alt.	2800	2800	7260	7260	7260	7260	7260	7260	7260
10 ³ / ₄ ^c	10.750	0.156	17.67	10.438	Std.	520	610	1040	1130	1280	1380	1480	1600	1730
					Alt.	650	760	1040	1130	1280	1380	1480	1600	1730
10 ³ / ₄ ^c	10.750	0.188	21.23	10.374	Std.	630	730	1250	1370	1550	1660	1780	1930	2080
					Alt.	790	920	1250	1370	1550	1660	1780	1930	2080
10 ³ / ₄ ^c	10.750	0.203	22.89	10.344	Std.	680	790	1350	1480	1670	1800	1930	2090	2250
					Alt.	850	990	1350	1480	1670	1800	1930	2090	2250
10 ³ / ₄	10.750	0.219	24.65	10.312	Std.	730	860	1450	1590	1800	1940	2080	2250	2420
					Alt.	920	1070	1450	1590	1800	1940	2080	2250	2420
10 ³ / ₄	10.750	0.250	28.06	10.250	Std.	840	980	1660	1820	2060	2210	2370	2570	2770
					Alt.	1050	1220	1660	1820	2060	2210	2370	2570	2770
10 ³ / ₄	10.750	0.279	31.23	10.192	Std.	930	1090	1850	2030	2290	2470	2650	2870	3000
					Alt.	1170	1360	1850	2030	2290	2470	2650	2870	3090
10 ³ / ₄	10.750	0.307	34.27	10.136	Std.	1030	1200	2040	2230	2520	2720	2910	3000	3000
					Alt.	1290	1500	2040	2230	2520	2720	2910	3160	3400
10 ³ / ₄	10.750	0.344	38.27	10.062	Std.	1150	1340	2280	2500	2830	3000	3000	3000	3000
					Alt.	1440	1680	2280	2500	2830	3050	3260	3540	3810
10 ³ / ₄	10.750	0.365	40.52	10.020	Std.	1220	1430	2420	2660	3000	3000	3000	3000	3000
					Alt.	1530	1780	2420	2660	3000	3230	3460	3750	4040
10 ³ / ₄	10.750	0.438	48.28	9.874	Std.	1470	1710	2910	3000	3000	3000	3000	3000	3000
					Alt.	1830	2140	2910	3190	3600	3880	4160	4500	4850
10 ³ / ₄	10.750	0.500	54.79	9.750	Std.	1670	1950	3000	3000	3000	3000	3000	3000	3000
					Alt.	2090	2440	3320	3640	4110	4430	4740	5140	5530
10 ³ / ₄	10.750	0.562	61.21	9.626	Std.	1880	2200	3000	3000	3000	3000	3000	3000	3000
					Alt.	2350	2740	3730	4090	4620	4980	5330	5780	6220
10 ³ / ₄	10.750	0.625	67.65	9.500	Std.	2090	2440	3000	3000	3000	3000	3000	3000	3000
					Alt.	2620	2800	4150	4550	5140	5530	5930	6420	6920
10 ³ / ₄	10.750	0.719	77.10	9.312	Std.	2410	2800	3000	3000	3000	3000	3000	3000	3000
					Alt.	2800	2800	4780	5230	5910	6370	6820	7260	7260
10 ³ / ₄	10.750	0.812	86.26	9.126	Std.	2720	2800	3000	3000	3000	3000	3000	3000	3000
					Alt.	2800	2800	5390	5910	6680	7190	7260	7260	7260
10 ³ / ₄	10.750	0.875	92.37	9.000	Std.	2800	2800	3000	3000	3000	3000	3000	3000	3000
					Alt.	2800	2800	5810	6370	7200	7260	7260	7260	7260
10 ³ / ₄	10.750	0.938	98.39	8.874	Std.	2800	2800	3000	3000	3000	3000	3000	3000	3000
					Alt.	2800	2800	6230	6820	7260	7260	7260	7260	7260
10 ³ / ₄	10.750	1.000	104.23	8.750	Std.	2800	2800	3000	3000	3000	3000	3000	3000	3000
					Alt.	2800	2800	6640	7260	7260	7260	7260	7260	7260
10 ³ / ₄	10.750	1.250	126.94	8.250	Std.	2800	2800	3000	3000	3000	3000	3000	3000	3000
					Alt.	2800	2800	7260	7260	7260	7260	7260	7260	7260
12 ³ / ₄ ^c	12.750	0.172	23.13	12.406	Std.	490	570	960	1050	1190	1280	1380	1490	
					Alt.	610	710	960	1050	1190	1280	1380	1490	1610
12 ³ / ₄ ^c	12.750	0.188	25.25	12.374	Std.	530	620	1050	1150	1300	1400	1500	1630	
					Alt.	660	770	1050	1150	1300	1400	1500	1630	1750
12 ³ / ₄ ^c	12.750	0.203	27.23	12.344	Std.	570	670	1140	1250	1410	1520	1620	1760	
					Alt.	720	840	1140	1250	1410	1520	1620	1760	1890
12 ³ / ₄ ^c	12.750	0.219	29.34	12.312	Std.	620	720	1230	1340	1520	1640	1750	1900	
					Alt.	770	900	1230	1340	1520	1640	1750	1900	2040
12 ³ / ₄	12.750	0.250	33.41	12.250	Std.	710	820	1400	1530	1730	1870	2000	2170	
					Alt.	880	1030	1400	1530	1730	1870	2000	2170	2330

Table 6C (Continued)—Plain-end Line Pipe Dimensions, Weights per Unit Length, and Test Pressures for Sizes 6⁵/₈ through 80 (U.S. Customary Units)

(1)	(2)	(3)	(4)	(5)	(6)	(7)	(8)	(9)	(10)	(11)	(12)	(13)	(14)	(15)	
Size	Specified Outside Diameter <i>D</i> (in.)	Specified Wall Thickness <i>t</i> (in.)	Plain-end Weight per Unit Length <i>w_{pe}</i> (lb/ft)	Calculated Inside Diameter ^a <i>d</i> (in.)	Minimum Test Pressure (psi) ^b										
					Grade A	Grade B	Grade X42	Grade X46	Grade X52	Grade X56	Grade X60	Grade X65	Grade X70	Grade X80	
12 ³ / ₄	12.750	0.281	37.46	12.188	Std.	790	930	1570	1720	1950	2100	2250	2440	2620	3000
					Alt.	990	1160	1570	1720	1950	2100	2250	2440	2620	3000
12 ³ / ₄	12.750	0.312	41.48	12.126	Std.	880	1030	1750	1910	2160	2330	2500	2700	2910	3000
					Alt.	1100	1280	1750	1910	2160	2330	2500	2700	2910	3330
12 ³ / ₄	12.750	0.330	43.81	12.090	Std.	930	1090	1850	2020	2290	2460	2640	2860	3000	3000
					Alt.	1160	1360	1850	2020	2290	2460	2640	2860	3080	3520
12 ³ / ₄	12.750	0.344	45.62	12.062	Std.	970	1130	1930	2110	2390	2570	2750	2980	3000	3000
					Alt.	1210	1420	1930	2110	2390	2570	2750	2980	3210	3670
12 ³ / ₄	12.750	0.375	49.61	12.000	Std.	1060	1240	2100	2300	2600	2800	3000	3000	3000	3000
					Alt.	1320	1540	2100	2300	2600	2800	3000	3000	3250	3500
12 ³ / ₄	12.750	0.406	53.57	11.938	Std.	1150	1340	2270	2490	2810	3000	3000	3000	3000	3000
					Alt.	1430	1670	2270	2490	2810	3030	3250	3520	3790	4330
12 ³ / ₄	12.750	0.438	57.65	11.874	Std.	1240	1440	2450	2690	3000	3000	3000	3000	3000	3000
					Alt.	1550	1800	2450	2690	3040	3270	3500	3800	4090	4670
12 ³ / ₄	12.750	0.500	65.48	11.750	Std.	1410	1650	2800	3000	3000	3000	3000	3000	3000	3000
					Alt.	1760	2060	2800	3070	3470	3730	4000	4330	4670	5330
12 ³ / ₄	12.750	0.562	73.22	11.626	Std.	1590	1850	3000	3000	3000	3000	3000	3000	3000	3000
					Alt.	1980	2310	3150	3450	3900	4200	4500	4870	5250	5990
12 ³ / ₄	12.750	0.625	81.01	11.500	Std.	1760	2060	3000	3000	3000	3000	3000	3000	3000	3000
					Alt.	2210	2570	3500	3830	4330	4670	5000	5420	5830	6670
12 ³ / ₄	12.750	0.688	88.71	11.374	Std.	1940	2270	3000	3000	3000	3000	3000	3000	3000	3000
					Alt.	2430	2800	3850	4220	4770	5140	5500	5960	6420	7260
12 ³ / ₄	12.750	0.750	96.21	11.250	Std.	2120	2470	3000	3000	3000	3000	3000	3000	3000	3000
					Alt.	2650	2800	4200	4600	5200	5600	6000	6500	7000	7260
12 ³ / ₄	12.750	0.812	103.63	11.126	Std.	2290	2670	3000	3000	3000	3000	3000	3000	3000	3000
					Alt.	2800	2800	4550	4980	5630	6060	6500	7040	7260	7260
12 ³ / ₄	12.750	0.875	111.08	11.000	Std.	2470	2800	3000	3000	3000	3000	3000	3000	3000	3000
					Alt.	2800	2800	4900	5370	6070	6530	7000	7260	7260	7260
12 ³ / ₄	12.750	0.938	118.44	10.874	Std.	2650	2800	3000	3000	3000	3000	3000	3000	3000	3000
					Alt.	2800	2800	5250	5750	6500	7000	7260	7260	7260	7260
12 ³ / ₄	12.750	1.000	125.61	10.750	Std.	2800	2800	3000	3000	3000	3000	3000	3000	3000	3000
					Alt.	2800	2800	5600	6130	6930	7260	7260	7260	7260	7260
12 ³ / ₄	12.750	1.062	132.69	10.626	Std.	2800	2800	3000	3000	3000	3000	3000	3000	3000	3000
					Alt.	2800	2800	5950	6510	7260	7260	7260	7260	7260	7260
12 ³ / ₄	12.750	1.125	139.81	10.500	Std.	2800	2800	3000	3000	3000	3000	3000	3000	3000	3000
					Alt.	2800	2800	6300	6900	7260	7260	7260	7260	7260	7260
12 ³ / ₄	12.750	1.250	153.67	10.250	Std.	2800	2800	3000	3000	3000	3000	3000	3000	3000	3000
					Alt.	2800	2800	7000	7260	7260	7260	7260	7260	7260	7260
14 ^c	14.000	0.188	27.76	13.624	Std.	480	560	960	1050	1190	1280	1370	1480	1600	1830
					Alt.	600	710	960	1050	1190	1280	1370	1480	1600	1830
14 ^c	14.000	0.203	29.94	13.594	Std.	520	610	1040	1130	1280	1380	1480	1600	1730	1970
					Alt.	650	760	1040	1130	1280	1380	1480	1600	1730	1970
14 ^c	14.000	0.210	30.96	13.580	Std.	540	630	1070	1170	1330	1430	1530	1660	1790	2040
					Alt.	680	790	1070	1170	1330	1430	1530	1660	1790	2040
14 ^c	14.000	0.219	32.26	13.562	Std.	560	660	1120	1220	1380	1490	1600	1730	1860	2130
					Alt.	700	820	1120	1220	1380	1490	1600	1730	1860	2130
14 ^c	14.000	0.250	36.75	13.500	Std.	640	750	1280	1400	1580	1700	1820	1970	2130	2430
					Alt.	800	940	1280	1400	1580	1700	1820	1970	2130	2430
14 ^c	14.000	0.281	41.21	13.438	Std.	720	840	1430	1570	1770	1910	2050	2220	2390	2730
					Alt.	900	1050	1430	1570	1770	1910	2050	2220	2390	2730

Table 6C (Continued)—Plain-end Line Pipe Dimensions, Weights per Unit Length, and Test Pressures for Sizes 6⁵/₈ through 80 (U.S. Customary Units)

(1)	(2)	(3)	(4)	(5)	(6)	(7)	(8)	(9)	(10)	(11)	(12)	(13)	(14)	(15)	
Size	Specified Outside Diameter <i>D</i> (in.)	Specified Wall Thickness <i>t</i> (in.)	Plain-end Weight per Unit Length <i>w_{pe}</i> (lb/ft)	Calculated Inside Diameter ^a <i>d</i> (in.)	Minimum Test Pressure (psi) ^b										
					Grade A	Grade B	Grade X42	Grade X46	Grade X52	Grade X56	Grade X60	Grade X65	Grade X70	Grade X80	
14	14.000	0.312	45.65	13.376	Std.	800	940	1590	1740	1970	2120	2270	2460	2650	3000
					Alt.	1000	1170	1590	1740	1970	2120	2270	2460	2650	3030
14	14.000	0.344	50.22	13.312	Std.	880	1030	1750	1920	2170	2340	2510	2720	2920	3000
					Alt.	1110	1290	1750	1920	2170	2340	2510	2720	2920	3340
14	14.000	0.375	54.62	13.250	Std.	960	1130	1910	2090	2370	2550	2730	2960	3000	3000
					Alt.	1210	1410	1910	2090	2370	2550	2730	2960	3190	3640
14	14.000	0.406	59.00	13.188	Std.	1040	1220	2070	2270	2560	2760	2960	3000	3000	3000
					Alt.	1310	1520	2070	2270	2560	2760	2960	3200	3450	3940
14	14.000	0.438	63.50	13.124	Std.	1130	1310	2230	2450	2770	2980	3000	3000	3000	3000
					Alt.	1410	1640	2230	2450	2770	2980	3190	3460	3720	4250
14	14.000	0.469	67.84	13.062	Std.	1210	1410	2390	2620	2960	3000	3000	3000	3000	3000
					Alt.	1510	1760	2390	2620	2960	3190	3420	3700	3990	4560
14	14.000	0.500	72.16	13.000	Std.	1290	1500	2550	2790	3000	3000	3000	3000	3000	3000
					Alt.	1610	1880	2550	2790	3160	3400	3640	3950	4250	4860
14	14.000	0.562	80.73	12.876	Std.	1450	1690	2870	3000	3000	3000	3000	3000	3000	3000
					Alt.	1810	2110	2870	3140	3550	3820	4090	4440	4780	5460
14	14.000	0.625	89.36	12.750	Std.	1610	1880	3000	3000	3000	3000	3000	3000	3000	3000
					Alt.	2010	2340	3190	3490	3950	4250	4550	4930	5310	6070
14	14.000	0.688	97.91	12.624	Std.	1770	2060	3000	3000	3000	3000	3000	3000	3000	3000
					Alt.	2210	2580	3510	3840	4340	4680	5010	5430	5850	6680
14	14.000	0.750	106.23	12.500	Std.	1930	2250	3000	3000	3000	3000	3000	3000	3000	3000
					Alt.	2410	2800	3830	4190	4740	5100	5460	5920	6380	7260
14	14.000	0.812	114.48	12.376	Std.	2090	2440	3000	3000	3000	3000	3000	3000	3000	3000
					Alt.	2610	2800	4140	4540	5130	5520	5920	6410	6900	7260
14	14.000	0.875	122.77	12.250	Std.	2250	2630	3000	3000	3000	3000	3000	3000	3000	3000
					Alt.	2800	2800	4460	4890	5530	5950	6380	6910	7260	7260
14	14.000	0.938	130.98	12.124	Std.	2410	2800	3000	3000	3000	3000	3000	3000	3000	3000
					Alt.	2800	2800	4780	5240	5920	6380	6830	7260	7260	7260
14	14.000	1.000	138.97	12.000	Std.	2570	2800	3000	3000	3000	3000	3000	3000	3000	3000
					Alt.	2800	2800	5100	5590	6310	6800	7260	7260	7260	7260
14	14.000	1.062	146.88	11.876	Std.	2730	2800	3000	3000	3000	3000	3000	3000	3000	3000
					Alt.	2800	2800	5420	5930	6710	7220	7260	7260	7260	7260
14	14.000	1.125	154.84	11.750	Std.	2800	2800	3000	3000	3000	3000	3000	3000	3000	3000
					Alt.	2800	2800	5740	6280	7100	7260	7260	7260	7260	7260
14	14.000	1.250	170.37	11.500	Std.	2800	2800	3000	3000	3000	3000	3000	3000	3000	3000
					Alt.	2800	2800	6380	6980	7260	7260	7260	7260	7260	7260
16 ^c	16.000	0.188	31.78	15.624	Std.	420	490	840	920	1040	1120	1200	1300	1400	1600
					Alt.	530	620	840	920	1040	1120	1200	1300	1400	1600
16 ^c	16.000	0.203	34.28	15.594	Std.	460	530	910	990	1120	1210	1290	1400	1510	1730
					Alt.	570	670	910	990	1120	1210	1290	1400	1510	1730
16 ^c	16.000	0.219	36.95	15.562	Std.	490	570	980	1070	1210	1300	1400	1510	1630	1860
					Alt.	620	720	980	1070	1210	1300	1400	1510	1630	1860
16 ^c	16.000	0.250	42.09	15.500	Std.	560	660	1120	1220	1380	1490	1590	1730	1860	2130
					Alt.	700	820	1120	1220	1380	1490	1590	1730	1860	2130
16 ^c	16.000	0.281	47.22	15.438	Std.	630	740	1250	1370	1550	1670	1790	1940	2090	2390
					Alt.	790	920	1250	1370	1550	1670	1790	1940	2090	2390
16	16.000	0.312	52.32	15.376	Std.	700	820	1390	1520	1720	1860	1990	2150	2320	2650
					Alt.	880	1020	1390	1520	1720	1860	1990	2150	2320	2650
16	16.000	0.344	57.57	15.312	Std.	770	900	1540	1680	1900	2050	2190	2380	2560	2920
					Alt.	970	1130	1540	1680	1900	2050	2190	2380	2560	2920

Table 6C (Continued)—Plain-end Line Pipe Dimensions, Weights per Unit Length, and Test Pressures for Sizes 6⁵/₈ through 80 (U.S. Customary Units)

(1)	(2)	(3)	(4)	(5)	(6)	(7)	(8)	(9)	(10)	(11)	(12)	(13)	(14)	(15)	
Size	Specified Outside Diameter <i>D</i> (in.)	Specified Wall Thickness <i>t</i> (in.)	Plain-end Weight per Unit Length <i>w_{pe}</i> (lb/ft)	Calculated Inside Diameter ^d <i>d</i> (in.)	Minimum Test Pressure (psi) ^b										
					Grade A	Grade B	Grade X42	Grade X46	Grade X52	Grade X56	Grade X60	Grade X65	Grade X70	Grade X80	
16	16.000	0.375	62.64	15.250	Std.	840	980	1670	1830	2070	2230	2390	2590	2790	3000
					Alt.	1050	1230	1670	1830	2070	2230	2390	2590	2790	3190
16	16.000	0.406	67.68	15.188	Std.	910	1070	1810	1980	2240	2420	2590	2800	3000	3000
					Alt.	1140	1330	1810	1980	2240	2420	2590	2800	3020	3450
16	16.000	0.438	72.86	15.124	Std.	990	1150	1950	2140	2420	2610	2790	3000	3000	3000
					Alt.	1230	1440	1950	2140	2420	2610	2790	3020	3260	3630
16	16.000	0.469	77.87	15.062	Std.	1060	1230	2090	2290	2590	2790	2990	3000	3000	3000
					Alt.	1320	1540	2090	2290	2590	2790	2990	3240	3490	3630
16	16.000	0.500	82.85	15.000	Std.	1130	1310	2230	2440	2760	2980	3000	3000	3000	3000
					Alt.	1410	1640	2230	2440	2760	2980	3190	3450	3630	3630
16	16.000	0.562	92.75	14.876	Std.	1260	1480	2510	2750	3000	3000	3000	3000	3000	3000
					Alt.	1580	1840	2510	2750	3110	3340	3580	3630	3630	3630
16	16.000	0.625	102.72	14.750	Std.	1410	1640	2790	3000	3000	3000	3000	3000	3000	3000
					Alt.	1760	2050	2790	3050	3450	3630	3630	3630	3630	3630
16	16.000	0.688	112.62	14.624	Std.	1550	1810	3000	3000	3000	3000	3000	3000	3000	3000
					Alt.	1940	2260	3070	3360	3630	3630	3630	3630	3630	3630
16	16.000	0.750	122.27	14.500	Std.	1690	1970	3000	3000	3000	3000	3000	3000	3000	3000
					Alt.	2110	2460	3350	3630	3630	3630	3630	3630	3630	3630
16	16.000	0.812	131.84	14.376	Std.	1830	2130	3000	3000	3000	3000	3000	3000	3000	3000
					Alt.	2280	2660	3620	3630	3630	3630	3630	3630	3630	3630
16	16.000	0.875	141.48	14.250	Std.	1970	2300	3000	3000	3000	3000	3000	3000	3000	3000
					Alt.	2460	2800	3630	3630	3630	3630	3630	3630	3630	3630
16	16.000	0.938	151.03	14.124	Std.	2110	2460	3000	3000	3000	3000	3000	3000	3000	3000
					Alt.	2640	2800	3630	3630	3630	3630	3630	3630	3630	3630
16	16.000	1.000	160.35	14.000	Std.	2250	2630	3000	3000	3000	3000	3000	3000	3000	3000
					Alt.	2800	2800	3630	3630	3630	3630	3630	3630	3630	3630
16	16.000	1.062	169.59	13.876	Std.	2390	2790	3000	3000	3000	3000	3000	3000	3000	3000
					Alt.	2800	2800	3630	3630	3630	3630	3630	3630	3630	3630
16	16.000	1.125	178.89	13.750	Std.	2530	2800	3000	3000	3000	3000	3000	3000	3000	3000
					Alt.	2800	2800	3630	3630	3630	3630	3630	3630	3630	3630
16	16.000	1.188	188.11	13.624	Std.	2670	2800	3000	3000	3000	3000	3000	3000	3000	3000
					Alt.	2800	2800	3630	3630	3630	3630	3630	3630	3630	3630
16	16.000	1.250	197.10	13.500	Std.	2800	2800	3000	3000	3000	3000	3000	3000	3000	3000
					Alt.	2800	2800	3630	3630	3630	3630	3630	3630	3630	3630
18 ^c	18.000	0.188	35.80	17.624	Std.	380	440	750	820	920	990	1070	1150	1240	1420
					Alt.	470	550	750	820	920	990	1070	1150	1240	1420
18 ^c	18.000	0.219	41.63	17.562	Std.	440	510	870	950	1080	1160	1240	1340	1450	1650
					Alt.	550	640	870	950	1080	1160	1240	1340	1450	1650
18 ^c	18.000	0.250	47.44	17.500	Std.	500	580	990	1090	1230	1320	1420	1530	1650	1890
					Alt.	630	730	990	1090	1230	1320	1420	1530	1650	1890
18 ^c	18.000	0.281	53.23	17.438	Std.	560	660	1110	1220	1380	1490	1590	1730	1860	2120
					Alt.	700	820	1110	1220	1380	1490	1590	1730	1860	2120
18	18.000	0.312	58.99	17.376	Std.	620	730	1240	1360	1530	1650	1770	1920	2060	2360
					Alt.	780	910	1240	1360	1530	1650	1770	1920	2060	2360
18	18.000	0.344	64.93	17.312	Std.	690	800	1360	1490	1690	1820	1950	2110	2270	2600
					Alt.	860	1000	1360	1490	1690	1820	1950	2110	2270	2600
18	18.000	0.375	70.65	17.250	Std.	750	880	1490	1630	1840	1980	2130	2300	2480	2830
					Alt.	940	1090	1490	1630	1840	1980	2130	2300	2480	2830
18	18.000	0.406	76.36	17.188	Std.	810	950	1610	1760	1990	2150	2300	2490	2680	3000
					Alt.	1020	1180	1610	1760	1990	2150	2300	2490	2680	3070

Table 6C (Continued)—Plain-end Line Pipe Dimensions, Weights per Unit Length, and Test Pressures for Sizes 6⁵/₈ through 80 (U.S. Customary Units)

(1) Size	(2) Specified Outside Diameter <i>D</i> (in.)	(3) Specified Wall Thickness <i>t</i> (in.)	(4) Plain-end Weight per Unit Length <i>w_{pe}</i> (lb/ft)	(5) Calculated Inside Diameter ^a <i>d</i> (in.)	(6) through (15) Minimum Test Pressure (psi) ^b										
					Grade										
					A	B	X42	X46	X52	X56	X60	X65	X70	X80	
18	18.000	0.438	82.23	17.124	Std.	880	1020	1740	1900	2150	2320	2480	2690	2900	3000
					Alt.	1100	1280	1740	1900	2150	2320	2480	2690	2900	3310
18	18.000	0.469	87.89	17.062	Std.	940	1090	1860	2040	2300	2480	2660	2880	3000	3000
					Alt.	1170	1370	1860	2040	2300	2480	2660	2880	3100	3540
18	18.000	0.500	93.54	17.000	Std.	1000	1170	1980	2170	2460	2640	2830	3000	3000	3000
					Alt.	1250	1460	1980	2170	2460	2640	2830	3070	3310	3630
18	18.000	0.562	104.76	16.876	Std.	1120	1310	2230	2440	2760	2970	3000	3000	3000	3000
					Alt.	1410	1640	2230	2440	2760	2970	3180	3450	3630	3630
18	18.000	0.625	116.09	16.750	Std.	1250	1460	2480	2720	3000	3000	3000	3000	3000	3000
					Alt.	1560	1820	2480	2720	3070	3310	3540	3630	3630	3630
18	18.000	0.688	127.32	16.624	Std.	1380	1610	2730	2990	3000	3000	3000	3000	3000	3000
					Alt.	1720	2010	2730	2990	3380	3630	3630	3630	3630	3630
18	18.000	0.750	138.30	16.500	Std.	1500	1750	2980	3000	3000	3000	3000	3000	3000	3000
					Alt.	1880	2190	2980	3260	3630	3630	3630	3630	3630	3630
18	18.000	0.812	149.20	16.376	Std.	1620	1890	3000	3000	3000	3000	3000	3000	3000	3000
					Alt.	2030	2370	3220	3530	3630	3630	3630	3630	3630	3630
18	18.000	0.875	160.18	16.250	Std.	1750	2040	3000	3000	3000	3000	3000	3000	3000	3000
					Alt.	2190	2550	3470	3630	3630	3630	3630	3630	3630	3630
18	18.000	0.938	171.08	16.124	Std.	1880	2190	3000	3000	3000	3000	3000	3000	3000	3000
					Alt.	2350	2740	3630	3630	3630	3630	3630	3630	3630	3630
18	18.000	1.000	181.73	16.000	Std.	2000	2330	3000	3000	3000	3000	3000	3000	3000	3000
					Alt.	2500	2800	3630	3630	3630	3630	3630	3630	3630	3630
18	18.000	1.062	192.29	15.876	Std.	2120	2480	3000	3000	3000	3000	3000	3000	3000	3000
					Alt.	2660	2800	3630	3630	3630	3630	3630	3630	3630	3630
18	18.000	1.125	202.94	15.750	Std.	2250	2630	3000	3000	3000	3000	3000	3000	3000	3000
					Alt.	2800	2800	3630	3630	3630	3630	3630	3630	3630	3630
18	18.000	1.188	213.51	15.624	Std.	2380	2770	3000	3000	3000	3000	3000	3000	3000	3000
					Alt.	2800	2800	3630	3630	3630	3630	3630	3630	3630	3630
18	18.000	1.250	223.82	15.500	Std.	2500	2800	3000	3000	3000	3000	3000	3000	3000	3000
					Alt.	2800	2800	3630	3630	3630	3630	3630	3630	3630	3630
20 ^c	20.000	0.219	46.31	19.562	Std.	390	460	830	910	1020	1100	1180	1280	1380	1580
					Alt.	490	570	830	910	1020	1100	1180	1280	1380	1580
20 ^c	20.000	0.250	52.78	19.500	Std.	450	530	950	1040	1170	1260	1350	1460	1580	1800
					Alt.	560	660	950	1040	1170	1260	1350	1460	1580	1800
20 ^c	20.000	0.281	59.23	19.438	Std.	510	590	1060	1160	1320	1420	1520	1640	1770	2020
					Alt.	630	740	1060	1160	1320	1420	1520	1640	1770	2020
20	20.000	0.312	65.66	19.376	Std.	560	660	1180	1290	1460	1570	1680	1830	1970	2250
					Alt.	700	820	1180	1290	1460	1570	1680	1830	1970	2250
20	20.000	0.344	72.28	19.312	Std.	620	720	1300	1420	1610	1730	1860	2010	2170	2480
					Alt.	770	900	1300	1420	1610	1730	1860	2010	2170	2480
20	20.000	0.375	78.67	19.250	Std.	680	790	1420	1550	1760	1890	2030	2190	2360	2700
					Alt.	840	980	1420	1550	1760	1890	2030	2190	2360	2700
20	20.000	0.406	85.04	19.188	Std.	730	850	1530	1680	1900	2050	2190	2380	2560	2920
					Alt.	910	1070	1530	1680	1900	2050	2190	2380	2560	2920
20	20.000	0.438	91.59	19.124	Std.	790	920	1660	1810	2050	2210	2370	2560	2760	3000
					Alt.	990	1150	1660	1810	2050	2210	2370	2560	2760	3150
20	20.000	0.469	97.92	19.062	Std.	840	980	1770	1940	2190	2360	2530	2740	2950	3000
					Alt.	1060	1230	1770	1940	2190	2360	2530	2740	2950	3380
20	20.000	0.500	104.23	19.000	Std.	900	1050	1890	2070	2340	2520	2700	2930	3000	3000
					Alt.	1130	1310	1890	2070	2340	2520	2700	2930	3150	3600

Table 6C (Continued)—Plain-end Line Pipe Dimensions, Weights per Unit Length, and Test Pressures for Sizes 6⁵/₈ through 80 (U.S. Customary Units)

(1)	(2)	(3)	(4)	(5)	(6) (7) (8) (9) (10) (11) (12) (13) (14) (15)										
Size	Specified Outside Diameter <i>D</i> (in.)	Specified Wall Thickness <i>t</i> (in.)	Plain-end Weight per Unit Length <i>w_{pe}</i> (lb/ft)	Calculated Inside Diameter ^a <i>d</i> (in.)	Minimum Test Pressure (psi) ^b										
					Grade A	Grade B	Grade X42	Grade X46	Grade X52	Grade X56	Grade X60	Grade X65	Grade X70	Grade X80	
20	20.000	0.562	116.78	18.876	Std.	1010	1180	2120	2330	2630	2830	3000	3000	3000	3000
					Alt.	1260	1480	2120	2330	2630	2830	3000	3030	3290	3540
20	20.000	0.625	129.45	18.750	Std.	1130	1310	2360	2590	2930	3000	3000	3000	3000	3000
					Alt.	1410	1640	2360	2590	2930	3150	3380	3630	3630	3630
20	20.000	0.688	142.03	18.624	Std.	1240	1440	2600	2850	3000	3000	3000	3000	3000	3000
					Alt.	1550	1810	2600	2850	3220	3630	3630	3630	3630	3630
20	20.000	0.750	154.34	18.500	Std.	1350	1580	2840	3000	3000	3000	3000	3000	3000	3000
					Alt.	1690	1970	2840	3110	3510	3630	3630	3630	3630	3630
20	20.000	0.812	166.56	18.376	Std.	1460	1710	3000	3000	3000	3000	3000	3000	3000	3000
					Alt.	1830	2130	3070	3360	3630	3630	3630	3630	3630	3630
20	20.000	0.875	178.89	18.250	Std.	1580	1840	3000	3000	3000	3000	3000	3000	3000	3000
					Alt.	1970	2300	3310	3620	3630	3630	3630	3630	3630	3630
20	20.000	0.938	191.14	18.124	Std.	1690	1970	3000	3000	3000	3000	3000	3000	3000	3000
					Alt.	2110	2460	3550	3630	3630	3630	3630	3630	3630	3630
20	20.000	1.000	203.11	18.000	Std.	1800	2100	3000	3000	3000	3000	3000	3000	3000	3000
					Alt.	2250	2630	3630	3630	3630	3630	3630	3630	3630	3630
20	20.000	1.062	215.00	17.876	Std.	1910	2230	3000	3000	3000	3000	3000	3000	3000	3000
					Alt.	2390	2790	3630	3630	3630	3630	3630	3630	3630	3630
20	20.000	1.125	227.00	17.750	Std.	2030	2360	3000	3000	3000	3000	3000	3000	3000	3000
					Alt.	2530	2800	3630	3630	3630	3630	3630	3630	3630	3630
20	20.000	1.188	238.91	17.624	Std.	2140	2490	3000	3000	3000	3000	3000	3000	3000	3000
					Alt.	2670	2800	3630	3630	3630	3630	3630	3630	3630	3630
20	20.000	1.250	250.55	17.500	Std.	2250	2630	3000	3000	3000	3000	3000	3000	3000	3000
					Alt.	2800	2800	3630	3630	3630	3630	3630	3630	3630	3630
20	20.000	1.312	262.10	17.376	Std.	2360	2760	3000	3000	3000	3000	3000	3000	3000	3000
					Alt.	2800	2800	3630	3630	3630	3630	3630	3630	3630	3630
20	20.000	1.375	273.76	17.250	Std.	2480	2800	3000	3000	3000	3000	3000	3000	3000	3000
					Alt.	2800	2800	3630	3630	3630	3630	3630	3630	3630	3630
22 ^c	22.000	0.219	50.99	21.562	Std.	360	420	750	820	930	1000	1080	1160	1250	1430
					Alt.	450	520	750	820	930	1000	1080	1160	1250	1430
22 ^c	22.000	0.250	58.13	21.500	Std.	410	480	860	940	1060	1150	1230	1330	1430	1640
					Alt.	510	600	860	940	1060	1150	1230	1330	1430	1640
22 ^c	22.000	0.281	65.24	21.438	Std.	460	540	970	1060	1200	1290	1380	1490	1610	1840
					Alt.	570	670	970	1060	1200	1290	1380	1490	1610	1840
22	22.000	0.312	72.34	21.376	Std.	510	600	1070	1170	1330	1430	1530	1660	1790	2040
					Alt.	640	740	1070	1170	1330	1430	1530	1660	1790	2040
22	22.000	0.344	79.64	21.312	Std.	560	660	1180	1290	1460	1580	1690	1830	1970	2250
					Alt.	700	820	1180	1290	1460	1580	1690	1830	1970	2250
22	22.000	0.375	86.69	21.250	Std.	610	720	1290	1410	1600	1720	1840	1990	2150	2450
					Alt.	770	890	1290	1410	1600	1720	1840	1990	2150	2450
22	22.000	0.406	93.72	21.188	Std.	660	780	1400	1530	1730	1860	1990	2160	2330	2660
					Alt.	830	970	1400	1530	1730	1860	1990	2160	2330	2660
22	22.000	0.438	100.96	21.124	Std.	720	840	1510	1650	1860	2010	2150	2330	2510	2870
					Alt.	900	1050	1510	1650	1860	2010	2150	2330	2510	2870
22	22.000	0.469	107.95	21.062	Std.	770	900	1610	1770	2000	2150	2300	2490	2690	3000
					Alt.	960	1120	1610	1770	2000	2150	2300	2490	2690	3070
22	22.000	0.500	114.92	21.000	Std.	820	950	1720	1880	2130	2290	2450	2660	2860	3000
					Alt.	1020	1190	1720	1880	2130	2290	2450	2660	2860	3270
22	22.000	0.562	128.79	20.876	Std.	920	1070	1930	2120	2390	2570	2760	2990	3000	3000
					Alt.	1150	1340	1930	2120	2390	2570	2760	2990	3220	3630

Table 6C (Continued)—Plain-end Line Pipe Dimensions, Weights per Unit Length, and Test Pressures for Sizes 6⁵/₈ through 80 (U.S. Customary Units)

(1) Size	(2) Specified Outside Diameter <i>D</i> (in.)	(3) Specified Wall Thickness <i>t</i> (in.)	(4) Plain-end Weight per Unit Length <i>w_{pe}</i> (lb/ft)	(5) Calculated Inside Diameter ^a <i>d</i> (in.)	(6) through (15) Minimum Test Pressure (psi) ^b										
					Grade A	Grade B	Grade X42	Grade X46	Grade X52	Grade X56	Grade X60	Grade X65	Grade X70	Grade X80	
22	22.000	0.625	142.81	20.750	Std.	1020	1190	2150	2350	2660	2860	3000	3000	3000	3000
					Alt.	1280	1490	2150	2350	2660	2860	3070	3320	3580	3630
22	22.000	0.688	156.74	20.624	Std.	1130	1310	2360	2590	2930	3000	3000	3000	3000	3000
					Alt.	1410	1640	2360	2590	2930	3150	3380	3630	3630	3630
22	22.000	0.750	170.37	20.500	Std.	1230	1430	2580	2820	3000	3000	3000	3000	3000	3000
					Alt.	1530	1790	2580	2820	3190	3630	3630	3630	3630	3630
22	22.000	0.812	183.92	20.376	Std.	1330	1550	2790	3000	3000	3000	3000	3000	3000	3000
					Alt.	1660	1940	2790	3060	3450	3630	3630	3630	3630	3630
22	22.000	0.875	197.60	20.250	Std.	1430	1670	3000	3000	3000	3000	3000	3000	3000	3000
					Alt.	1790	2090	3010	3290	3630	3630	3630	3630	3630	3630
22	22.000	0.938	211.19	20.124	Std.	1530	1790	3000	3000	3000	3000	3000	3000	3000	3000
					Alt.	1920	2240	3220	3530	3630	3630	3630	3630	3630	3630
22	22.000	1.000	224.49	20.000	Std.	1640	1910	3000	3000	3000	3000	3000	3000	3000	3000
					Alt.	2050	2390	3440	3630	3630	3630	3630	3630	3630	3630
22	22.000	1.062	237.70	19.876	Std.	1740	2030	3000	3000	3000	3000	3000	3000	3000	3000
					Alt.	2170	2530	3630	3630	3630	3630	3630	3630	3630	3630
22	22.000	1.125	251.05	19.750	Std.	1840	2150	3000	3000	3000	3000	3000	3000	3000	3000
					Alt.	2300	2680	3630	3630	3630	3630	3630	3630	3630	3630
22	22.000	1.188	264.31	19.624	Std.	1940	2270	3000	3000	3000	3000	3000	3000	3000	3000
					Alt.	2430	2800	3630	3630	3630	3630	3630	3630	3630	3630
22	22.000	1.250	277.27	19.500	Std.	2050	2390	3000	3000	3000	3000	3000	3000	3000	3000
					Alt.	2560	2800	3630	3630	3630	3630	3630	3630	3630	3630
22	22.000	1.312	290.15	19.376	Std.	2150	2500	3000	3000	3000	3000	3000	3000	3000	3000
					Alt.	2680	2800	3630	3630	3630	3630	3630	3630	3630	3630
22	22.000	1.375	303.16	19.250	Std.	2250	2630	3000	3000	3000	3000	3000	3000	3000	3000
					Alt.	2800	2800	3630	3630	3630	3630	3630	3630	3630	3630
22	22.000	1.438	316.08	19.124	Std.	2350	2750	3000	3000	3000	3000	3000	3000	3000	3000
					Alt.	2800	2800	3630	3630	3630	3630	3630	3630	3630	3630
22	22.000	1.500	328.72	19.000	Std.	2450	2800	3000	3000	3000	3000	3000	3000	3000	3000
					Alt.	2800	2800	3630	3630	3630	3630	3630	3630	3630	3630
24 ^c	24.000	0.250	63.47	23.500	Std.	380	440	790	860	980	1050	1130	1220	1310	1500
					Alt.	470	550	790	860	980	1050	1130	1220	1310	1500
24 ^c	24.000	0.281	71.25	23.438	Std.	420	490	890	970	1100	1180	1260	1370	1480	1690
					Alt.	530	610	890	970	1100	1180	1260	1370	1480	1690
24	24.000	0.312	79.01	23.376	Std.	470	550	980	1080	1220	1310	1400	1520	1640	1870
					Alt.	590	680	980	1080	1220	1310	1400	1520	1640	1870
24	24.000	0.344	86.99	23.312	Std.	520	600	1080	1190	1340	1440	1550	1680	1810	2060
					Alt.	650	750	1080	1190	1340	1440	1550	1680	1810	2060
24	24.000	0.375	94.71	23.250	Std.	560	660	1180	1290	1460	1580	1690	1830	1970	2250
					Alt.	700	820	1180	1290	1460	1580	1690	1830	1970	2250
24	24.000	0.406	102.40	23.188	Std.	610	710	1280	1400	1580	1710	1830	1980	2130	2440
					Alt.	760	890	1280	1400	1580	1710	1830	1980	2130	2440
24	24.000	0.438	110.32	23.124	Std.	660	770	1380	1510	1710	1840	1970	2140	2300	2630
					Alt.	820	960	1380	1510	1710	1840	1970	2140	2300	2630
24	24.000	0.469	117.98	23.062	Std.	700	820	1480	1620	1830	1970	2110	2290	2460	2810
					Alt.	880	1030	1480	1620	1830	1970	2110	2290	2460	2810
24	24.000	0.500	125.61	23.000	Std.	750	880	1580	1730	1950	2100	2250	2440	2630	3000
					Alt.	940	1090	1580	1730	1950	2100	2250	2440	2630	3000
24	24.000	0.562	140.81	22.876	Std.	840	980	1770	1940	2190	2360	2530	2740	2950	3000
					Alt.	1050	1230	1770	1940	2190	2360	2530	2740	2950	3370

Table 6C (Continued)—Plain-end Line Pipe Dimensions, Weights per Unit Length, and Test Pressures for Sizes 6⁵/₈ through 80 (U.S. Customary Units)

(1)	(2)	(3)	(4)	(5)	(6)	(7)	(8)	(9)	(10)	(11)	(12)	(13)	(14)	(15)	
Size	Specified Outside Diameter <i>D</i> (in.)	Specified Wall Thickness <i>t</i> (in.)	Plain-end Weight per Unit Length <i>w_{pe}</i> (lb/ft)	Calculated Inside Diameter ^a <i>d</i> (in.)	Minimum Test Pressure (psi) ^b										
					Grade A	Grade B	Grade X42	Grade X46	Grade X52	Grade X56	Grade X60	Grade X65	Grade X70	Grade X80	
24	24.000	0.625	156.17	22.750	Std.	940	1090	1970	2160	2440	2630	2810	3000	3000	3000
					Alt.	1170	1370	1970	2160	2440	2630	2810	3050	3280	3630
24	24.000	0.688	171.45	22.624	Std.	1030	1200	2170	2370	2680	2890	3000	3000	3000	3000
					Alt.	1290	1510	2170	2370	2680	2890	3100	3350	3610	3630
24	24.000	0.750	186.41	22.500	Std.	1130	1310	2360	2590	2930	3000	3000	3000	3000	3000
					Alt.	1410	1640	2360	2590	2930	3150	3380	3630	3630	3630
24	24.000	0.812	201.28	22.376	Std.	1220	1420	2560	2800	3000	3000	3000	3000	3000	3000
					Alt.	1520	1780	2560	2800	3170	3630	3630	3630	3630	3630
24	24.000	0.875	216.31	22.250	Std.	1310	1530	2760	3000	3000	3000	3000	3000	3000	3000
					Alt.	1640	1910	2760	3020	3410	3630	3630	3630	3630	3630
24	24.000	0.938	231.25	22.124	Std.	1410	1640	2950	3000	3000	3000	3000	3000	3000	3000
					Alt.	1760	2050	2950	3240	3630	3630	3630	3630	3630	3630
24	24.000	1.000	245.87	22.000	Std.	1500	1750	3000	3000	3000	3000	3000	3000	3000	3000
					Alt.	1880	2190	3150	3450	3630	3630	3630	3630	3630	3630
24	24.000	1.062	260.41	21.876	Std.	1590	1860	3000	3000	3000	3000	3000	3000	3000	3000
					Alt.	1990	2320	3350	3630	3630	3630	3630	3630	3630	3630
24	24.000	1.125	275.10	21.750	Std.	1690	1970	3000	3000	3000	3000	3000	3000	3000	3000
					Alt.	2110	2460	3540	3630	3630	3630	3630	3630	3630	3630
24	24.000	1.188	289.71	21.624	Std.	1780	2080	3000	3000	3000	3000	3000	3000	3000	3000
					Alt.	2230	2600	3630	3630	3630	3630	3630	3630	3630	3630
24	24.000	1.250	304.00	21.500	Std.	1880	2190	3000	3000	3000	3000	3000	3000	3000	3000
					Alt.	2340	2730	3630	3630	3630	3630	3630	3630	3630	3630
24	24.000	1.312	318.21	21.376	Std.	1970	2300	3000	3000	3000	3000	3000	3000	3000	3000
					Alt.	2460	2800	3630	3630	3630	3630	3630	3630	3630	3630
24	24.000	1.375	332.56	21.250	Std.	2060	2410	3000	3000	3000	3000	3000	3000	3000	3000
					Alt.	2580	2800	3630	3630	3630	3630	3630	3630	3630	3630
24	24.000	1.438	346.83	21.124	Std.	2160	2520	3000	3000	3000	3000	3000	3000	3000	3000
					Alt.	2700	2800	3630	3630	3630	3630	3630	3630	3630	3630
24	24.000	1.500	360.79	21.000	Std.	2250	2630	3000	3000	3000	3000	3000	3000	3000	3000
					Alt.	2800	2800	3630	3630	3630	3630	3630	3630	3630	3630
24	24.000	1.562	374.66	20.876	Std.	2340	2730	3000	3000	3000	3000	3000	3000	3000	3000
					Alt.	2800	2800	3630	3630	3630	3630	3630	3630	3630	3630
26 ^c	26.000	0.250	68.82	25.500	Std.	350	400	730	800	900	970	1040	1130	1210	1380
					Alt.	430	500	730	800	900	970	1040	1130	1210	1380
26 ^c	26.000	0.281	77.26	25.438	Std.	390	450	820	890	1010	1090	1170	1260	1360	1560
					Alt.	490	570	820	890	1010	1090	1170	1260	1360	1560
26	26.000	0.312	85.68	25.376	Std.	430	500	910	990	1120	1210	1300	1400	1510	1730
					Alt.	540	630	910	990	1120	1210	1300	1400	1510	1730
26	26.000	0.344	94.35	25.312	Std.	480	560	1000	1100	1240	1330	1430	1550	1670	1910
					Alt.	600	690	1000	1100	1240	1330	1430	1550	1670	1910
26	26.000	0.375	102.72	25.250	Std.	520	610	1090	1190	1350	1450	1560	1690	1820	2080
					Alt.	650	760	1090	1190	1350	1450	1560	1690	1820	2080
26	26.000	0.406	111.08	25.188	Std.	560	660	1180	1290	1460	1570	1690	1830	1970	2250
					Alt.	700	820	1180	1290	1460	1570	1690	1830	1970	2250
26	26.000	0.438	119.69	25.124	Std.	610	710	1270	1390	1580	1700	1820	1970	2120	2430
					Alt.	760	880	1270	1390	1580	1700	1820	1970	2120	2430
26	26.000	0.469	128.00	25.062	Std.	650	760	1360	1490	1690	1820	1950	2110	2270	2600
					Alt.	810	950	1360	1490	1690	1820	1950	2110	2270	2600
26	26.000	0.500	136.30	25.000	Std.	690	810	1450	1590	1800	1940	2080	2250	2420	2770
					Alt.	870	1010	1450	1590	1800	1940	2080	2250	2420	2770

Table 6C (Continued)—Plain-end Line Pipe Dimensions, Weights per Unit Length, and Test Pressures for Sizes 6⁵/₈ through 80 (U.S. Customary Units)

(1)	(2)	(3)	(4)	(5)	(6)	(7)	(8)	(9)	(10)	(11)	(12)	(13)	(14)	(15)	
Size	Specified Outside Diameter <i>D</i> (in.)	Specified Wall Thickness <i>t</i> (in.)	Plain-end Weight per Unit Length <i>w_{pe}</i> (lb/ft)	Calculated Inside Diameter ^a <i>d</i> (in.)	Minimum Test Pressure (psi) ^b										
					Grade A	Grade B	Grade X42	Grade X46	Grade X52	Grade X56	Grade X60	Grade X65	Grade X70	Grade X80	
26	26.000	0.562	152.83	24.876	Std.	780	910	1630	1790	2020	2180	2330	2530	2720	3000
					Alt.	970	1130	1630	1790	2020	2180	2330	2530	2720	3110
26	26.000	0.625	169.54	24.750	Std.	870	1010	1820	1990	2250	2420	2600	2810	3000	3000
					Alt.	1080	1260	1820	1990	2250	2420	2600	2810	3030	3460
26	26.000	0.688	186.16	24.624	Std.	950	1110	2000	2190	2480	2670	2860	3000	3000	3000
					Alt.	1190	1390	2000	2190	2480	2670	2860	3100	3330	3630
26	26.000	0.750	202.44	24.500	Std.	1040	1210	2180	2390	2700	2910	3000	3000	3000	3000
					Alt.	1300	1510	2180	2390	2700	2910	3120	3380	3630	3630
26	26.000	0.812	218.64	24.376	Std.	1120	1310	2360	2590	2920	3000	3000	3000	3000	3000
					Alt.	1410	1640	2360	2590	2920	3150	3370	3630	3630	3630
26	26.000	0.875	235.01	24.250	Std.	1210	1410	2540	2790	3000	3000	3000	3000	3000	3000
					Alt.	1510	1770	2540	2790	3150	3630	3630	3630	3630	3630
26	26.000	0.938	251.30	24.124	Std.	1300	1520	2730	2990	3000	3000	3000	3000	3000	3000
					Alt.	1620	1890	2730	2990	3380	3630	3630	3630	3630	3630
26	26.000	1.000	267.25	24.000	Std.	1380	1620	2910	3000	3000	3000	3000	3000	3000	3000
					Alt.	1730	2020	2910	3180	3600	3630	3630	3630	3630	3630
28 ^c	28.000	0.250	74.16	27.500	Std.	320	380	680	740	840	900	960	1040	1130	1290
					Alt.	400	470	680	740	840	900	960	1040	1130	1290
28 ^c	28.000	0.281	83.26	27.438	Std.	360	420	760	830	940	1010	1080	1170	1260	1450
					Alt.	450	530	760	830	940	1010	1080	1170	1260	1450
28	28.000	0.312	92.35	27.376	Std.	400	470	840	920	1040	1120	1200	1300	1400	1600
					Alt.	500	590	840	920	1040	1120	1200	1300	1400	1600
28	28.000	0.344	101.70	27.312	Std.	440	520	930	1020	1150	1240	1330	1440	1550	1770
					Alt.	550	650	930	1020	1150	1240	1330	1440	1550	1770
28	28.000	0.375	110.74	27.250	Std.	480	560	1010	1110	1250	1350	1450	1570	1690	1930
					Alt.	600	700	1010	1110	1250	1350	1450	1570	1690	1930
28	28.000	0.406	119.76	27.188	Std.	520	610	1100	1200	1360	1460	1570	1700	1830	2090
					Alt.	650	760	1100	1200	1360	1460	1570	1700	1830	2090
28	28.000	0.438	129.05	27.124	Std.	560	660	1180	1300	1460	1580	1690	1830	1970	2250
					Alt.	700	820	1180	1300	1460	1580	1690	1830	1970	2250
28	28.000	0.469	138.03	27.062	Std.	600	700	1270	1390	1570	1690	1810	1960	2110	2410
					Alt.	750	880	1270	1390	1570	1690	1810	1960	2110	2410
28	28.000	0.500	146.99	27.000	Std.	640	750	1350	1480	1670	1800	1930	2090	2250	2570
					Alt.	800	940	1350	1480	1670	1800	1930	2090	2250	2570
28	28.000	0.562	164.84	26.876	Std.	720	840	1520	1660	1880	2020	2170	2350	2530	2890
					Alt.	900	1050	1520	1660	1880	2020	2170	2350	2530	2890
28	28.000	0.625	182.90	26.750	Std.	800	940	1690	1850	2090	2250	2410	2610	2810	3000
					Alt.	1000	1170	1690	1850	2090	2250	2410	2610	2810	3210
28	28.000	0.688	200.87	26.624	Std.	880	1030	1860	2030	2300	2480	2650	2870	3000	3000
					Alt.	1110	1290	1860	2030	2300	2480	2650	2870	3100	3540
28	28.000	0.750	218.48	26.500	Std.	960	1130	2030	2220	2510	2700	2890	3000	3000	3000
					Alt.	1210	1410	2030	2220	2510	2700	2890	3130	3380	3630
28	28.000	0.812	236.00	26.376	Std.	1040	1220	2190	2400	2710	2920	3000	3000	3000	3000
					Alt.	1310	1520	2190	2400	2710	2920	3130	3390	3630	3630
28	28.000	0.875	253.72	26.250	Std.	1130	1310	2360	2590	2930	3000	3000	3000	3000	3000
					Alt.	1410	1640	2360	2590	2930	3150	3380	3630	3630	3630
28	28.000	0.938	271.36	26.124	Std.	1210	1410	2530	2770	3000	3000	3000	3000	3000	3000
					Alt.	1510	1760	2530	2770	3140	3630	3620	3630	3630	3630
28	28.000	1.000	288.63	26.000	Std.	1290	1500	2700	2960	3000	3000	3000	3000	3000	3000
					Alt.	1610	1880	2700	2960	3340	3630	3630	3630	3630	3630

Table 6C (Continued)—Plain-end Line Pipe Dimensions, Weights per Unit Length, and Test Pressures for Sizes 6⁵/₈ through 80 (U.S. Customary Units)

(1)	(2)	(3)	(4)	(5)	(6)	(7)	(8)	(9)	(10)	(11)	(12)	(13)	(14)	(15)	
Size	Specified Outside Diameter <i>D</i> (in.)	Specified Wall Thickness <i>t</i> (in.)	Plain-end Weight per Unit Length <i>w_{pe}</i> (lb/ft)	Calculated Inside Diameter ^a <i>d</i> (in.)	Minimum Test Pressure (psi) ^b										
					Grade A	Grade B	Grade X42	Grade X46	Grade X52	Grade X56	Grade X60	Grade X65	Grade X70	Grade X80	
30 ^c	30.000	0.250	79.51	29.500	Std.	300	350	630	690	780	840	900	980	1050	1200
					Alt.	380	440	630	690	780	840	900	980	1050	1200
30 ^c	30.000	0.281	89.27	29.438	Std.	340	390	710	780	880	940	1010	1100	1180	1350
					Alt.	420	490	710	780	880	940	1010	1100	1180	1350
30	30.000	0.312	99.02	29.376	Std.	370	440	790	860	970	1050	1120	1220	1310	1500
					Alt.	470	550	790	860	970	1050	1120	1220	1310	1500
30	30.000	0.344	109.06	29.312	Std.	410	480	870	950	1070	1160	1240	1340	1440	1650
					Alt.	520	600	870	950	1070	1160	1240	1340	1440	1650
30	30.000	0.375	118.76	29.250	Std.	450	530	950	1040	1170	1260	1350	1460	1580	1800
					Alt.	560	660	950	1040	1170	1260	1350	1460	1580	1800
30	30.000	0.406	128.44	29.188	Std.	490	570	1020	1120	1270	1360	1460	1580	1710	1950
					Alt.	610	710	1020	1120	1270	1360	1460	1580	1710	1950
30	30.000	0.438	138.42	29.124	Std.	530	610	1100	1210	1370	1470	1580	1710	1840	2100
					Alt.	660	770	1100	1210	1370	1470	1580	1710	1840	2100
30	30.000	0.469	148.06	29.062	Std.	560	660	1180	1290	1460	1580	1690	1830	1970	2250
					Alt.	700	820	1180	1290	1460	1580	1690	1830	1970	2250
30	30.000	0.500	157.68	29.000	Std.	600	700	1260	1380	1560	1680	1800	1950	2100	2400
					Alt.	750	880	1260	1380	1560	1680	1800	1950	2100	2400
30	30.000	0.562	176.86	28.876	Std.	670	790	1420	1550	1750	1890	2020	2190	2360	2700
					Alt.	840	980	1420	1550	1750	1890	2020	2190	2360	2700
30	30.000	0.625	196.26	28.750	Std.	750	880	1580	1730	1950	2100	2250	2440	2630	3000
					Alt.	940	1090	1580	1730	1950	2100	2250	2440	2630	3000
30	30.000	0.688	215.58	28.624	Std.	830	960	1730	1900	2150	2310	2480	2680	2890	3000
					Alt.	1030	1200	1730	1900	2150	2310	2480	2680	2890	3300
30	30.000	0.750	234.51	28.500	Std.	900	1050	1890	2070	2340	2520	2700	2930	3000	3600
					Alt.	1130	1310	1890	2070	2340	2520	2700	2930	3150	3600
30	30.000	0.812	253.36	28.376	Std.	970	1140	2050	2240	2530	2730	2920	3000	3000	3000
					Alt.	1220	1420	2050	2240	2530	2730	2920	3170	3410	3630
30	30.000	0.875	272.43	28.250	Std.	1050	1230	2210	2420	2730	2940	3000	3000	3000	3000
					Alt.	1310	1530	2210	2420	2730	2940	3150	3410	3630	3630
30	30.000	0.938	291.41	28.124	Std.	1130	1310	2360	2590	2930	3000	3000	3000	3000	3000
					Alt.	1410	1640	2360	2590	2930	3150	3380	3630	3630	3630
30	30.000	1.000	310.01	28.000	Std.	1200	1400	2520	2760	3000	3000	3000	3000	3000	3000
					Alt.	1500	1750	2520	2760	3120	3360	3600	3630	3630	3630
30	30.000	1.062	328.53	27.876	Std.	1270	1490	2680	2930	3000	3000	3000	3000	3000	3000
					Alt.	1590	1860	2680	2930	3310	3630	3630	3630	3630	3630
30	30.000	1.125	347.26	27.750	Std.	1350	1580	2840	3000	3000	3000	3000	3000	3000	3000
					Alt.	1690	1970	2840	3110	3510	3630	3630	3630	3630	3630
30	30.000	1.188	365.90	27.624	Std.	1430	1660	2990	3000	3000	3000	3000	3000	3000	3000
					Alt.	1780	2080	2990	3280	3630	3630	3630	3630	3630	3630
30	30.000	1.250	384.17	27.500	Std.	1500	1750	3000	3000	3000	3000	3000	3000	3000	3000
					Alt.	1880	2190	3150	3450	3630	3630	3630	3630	3630	3630
32 ^c	32.000	0.250	84.85	31.500	Std.	280	330	590	650	730	790	840	910	980	1130
					Alt.	350	410	590	650	730	790	840	910	980	1130
32 ^c	32.000	0.281	95.28	31.438	Std.	320	370	660	730	820	890	950	1030	1110	1260
					Alt.	400	460	660	730	820	890	950	1030	1110	1260
32	32.000	0.312	105.69	31.376	Std.	350	410	740	810	910	980	1050	1140	1230	1400
					Alt.	440	510	740	810	910	980	1050	1140	1230	1400
32	32.000	0.344	116.41	31.312	Std.	390	450	810	890	1010	1080	1160	1260	1350	1550
					Alt.	480	560	810	890	1010	1080	1160	1260	1350	1550

Table 6C (Continued)—Plain-end Line Pipe Dimensions, Weights per Unit Length, and Test Pressures for Sizes 6⁵/₈ through 80 (U.S. Customary Units)

(1) Size	(2) Specified Outside Diameter <i>D</i> (in.)	(3) Specified Wall Thickness <i>t</i> (in.)	(4) Plain-end Weight per Unit Length <i>w_{pe}</i> (lb/ft)	(5) Calculated Inside Diameter ^a <i>d</i> (in.)	(6) through (15) Minimum Test Pressure (psi) ^b										
					Grade										
					A	B	X42	X46	X52	X56	X60	X65	X70	X80	
32	32.000	0.375	126.78	31.250	Std.	420	490	890	970	1100	1180	1270	1370	1480	1690
					Alt.	530	620	890	970	1100	1180	1270	1370	1480	1690
32	32.000	0.406	137.12	31.188	Std.	460	530	960	1050	1190	1280	1370	1480	1600	1830
					Alt.	570	670	960	1050	1190	1280	1370	1480	1600	1830
32	32.000	0.438	147.78	31.124	Std.	490	570	1030	1130	1280	1380	1480	1600	1720	1970
					Alt.	620	720	1030	1130	1280	1380	1480	1600	1720	1970
32	32.000	0.469	158.08	31.062	Std.	530	620	1110	1210	1370	1480	1580	1710	1850	2110
					Alt.	660	770	1110	1210	1370	1480	1580	1710	1850	2110
32	32.000	0.500	168.37	31.000	Std.	560	660	1180	1290	1460	1580	1690	1830	1970	2250
					Alt.	700	820	1180	1290	1460	1580	1690	1830	1970	2250
32	32.000	0.562	188.87	30.876	Std.	630	740	1330	1450	1640	1770	1900	2050	2210	2530
					Alt.	790	920	1330	1450	1640	1770	1900	2050	2210	2530
32	32.000	0.625	209.62	30.750	Std.	700	820	1480	1620	1830	1970	2110	2290	2460	2810
					Alt.	880	1030	1480	1620	1830	1970	2110	2290	2460	2810
32	32.000	0.688	230.29	30.624	Std.	770	900	1630	1780	2010	2170	2320	2520	2710	3000
					Alt.	970	1130	1630	1780	2010	2170	2320	2520	2710	3100
32	32.000	0.750	250.55	30.500	Std.	840	980	1770	1940	2190	2360	2530	2740	2950	3000
					Alt.	1050	1230	1770	1940	2190	2360	2530	2740	2950	3380
32	32.000	0.812	270.72	30.376	Std.	910	1070	1920	2100	2380	2560	2740	2970	3000	3000
					Alt.	1140	1330	1920	2100	2380	2560	2740	2970	3200	3630
32	32.000	0.875	291.14	30.250	Std.	980	1150	2070	2260	2560	2760	2950	3000	3000	3000
					Alt.	1230	1440	2070	2260	2560	2760	2950	3200	3450	3630
32	32.000	0.938	311.47	30.124	Std.	1060	1230	2220	2430	2740	2950	3000	3000	3000	3000
					Alt.	1320	1540	2220	2430	2740	2950	3170	3430	3630	3630
32	32.000	1.000	331.39	30.000	Std.	1130	1310	2360	2590	2930	3000	3000	3000	3000	3000
					Alt.	1410	1640	2360	2590	2930	3150	3380	3630	3630	3630
32	32.000	1.062	351.23	29.876	Std.	1190	1390	2510	2750	3000	3000	3000	3000	3000	3000
					Alt.	1490	1740	2510	2750	3110	3350	3580	3630	3630	3630
32	32.000	1.125	371.31	29.750	Std.	1270	1480	2660	2910	3000	3000	3000	3000	3000	3000
					Alt.	1580	1850	2660	2910	3290	3540	3630	3630	3630	3630
32	32.000	1.188	391.30	29.624	Std.	1340	1560	2810	3000	3000	3000	3000	3000	3000	3000
					Alt.	1670	1950	2810	3070	3470	3630	3630	3630	3630	3630
32	32.000	1.250	410.90	29.500	Std.	1410	1640	2950	3000	3000	3000	3000	3000	3000	3000
					Alt.	1760	2050	2950	3230	3630	3630	3630	3630	3630	3630
34 ^c	34.000	0.250	90.20	33.500	Std.	260	310	560	610	690	740	790	860	930	1060
					Alt.	330	390	560	610	690	740	790	860	930	1060
34 ^c	34.000	0.281	101.29	33.438	Std.	300	350	620	680	770	830	890	970	1040	1190
					Alt.	370	430	620	680	770	830	890	970	1040	1190
34	34.000	0.312	112.36	33.376	Std.	330	390	690	760	860	920	990	1070	1160	1320
					Alt.	410	480	690	760	860	920	990	1070	1160	1320
34	34.000	0.344	123.77	33.312	Std.	360	420	760	840	950	1020	1090	1180	1270	1460
					Alt.	460	530	760	840	950	1020	1090	1180	1270	1460
34	34.000	0.375	134.79	33.250	Std.	400	460	830	910	1030	1110	1190	1290	1390	1590
					Alt.	500	580	830	910	1030	1110	1190	1290	1390	1590
34	34.000	0.406	145.80	33.188	Std.	430	500	900	990	1120	1200	1290	1400	1500	1720
					Alt.	540	630	900	990	1120	1200	1290	1400	1500	1720
34	34.000	0.438	157.14	33.124	Std.	460	540	970	1070	1210	1300	1390	1510	1620	1860
					Alt.	580	680	970	1070	1210	1300	1390	1510	1620	1860
34	34.000	0.469	168.11	33.062	Std.	500	580	1040	1140	1290	1390	1490	1610	1740	1990
					Alt.	620	720	1040	1140	1290	1390	1490	1610	1740	1990

Table 6C (Continued)—Plain-end Line Pipe Dimensions, Weights per Unit Length, and Test Pressures for Sizes 6⁵/₈ through 80 (U.S. Customary Units)

(1)	(2)	(3)	(4)	(5)	(6)	(7)	(8)	(9)	(10)	(11)	(12)	(13)	(14)	(15)	
Size	Specified Outside Diameter <i>D</i> (in.)	Specified Wall Thickness <i>t</i> (in.)	Plain-end Weight per Unit Length <i>w_{pe}</i> (lb/ft)	Calculated Inside Diameter ^d <i>d</i> (in.)	Minimum Test Pressure (psi) ^b										
					Grade A	Grade B	Grade X42	Grade X46	Grade X52	Grade X56	Grade X60	Grade X65	Grade X70	Grade X80	
34	34.000	0.500	179.06	33.000	Std.	530	620	1110	1220	1380	1480	1590	1720	1850	2120
					Alt.	660	770	1110	1220	1380	1480	1590	1720	1850	2120
34	34.000	0.562	200.89	32.876	Std.	600	690	1250	1370	1550	1670	1790	1930	2080	2380
					Alt.	740	870	1250	1370	1550	1670	1790	1930	2080	2380
34	34.000	0.625	222.99	32.750	Std.	660	770	1390	1520	1720	1850	1990	2150	2320	2650
					Alt.	830	970	1390	1520	1720	1850	1990	2150	2320	2650
34	34.000	0.688	245.00	32.624	Std.	730	850	1530	1680	1890	2040	2190	2370	2550	2910
					Alt.	910	1060	1530	1680	1890	2040	2190	2370	2550	2910
34	34.000	0.750	266.58	32.500	Std.	790	930	1670	1830	2060	2220	2380	2580	2780	3000
					Alt.	990	1160	1670	1830	2060	2220	2380	2580	2780	3180
34	34.000	0.812	288.08	32.376	Std.	860	1000	1810	1980	2240	2410	2580	2790	3000	3000
					Alt.	1070	1250	1810	1980	2240	2410	2580	2790	3010	3440
34	34.000	0.875	309.84	32.250	Std.	930	1080	1950	2130	2410	2590	2780	3000	3000	3000
					Alt.	1160	1350	1950	2130	2410	2590	2780	3010	3240	3630
34	34.000	0.938	331.52	32.124	Std.	990	1160	2090	2280	2580	2780	2980	3000	3000	3000
					Alt.	1240	1450	2090	2280	2580	2780	2980	3230	3480	3630
34	34.000	1.000	352.77	32.000	Std.	1060	1240	2220	2440	2750	2960	3000	3000	3000	3000
					Alt.	1320	1540	2220	2440	2750	2960	3180	3440	3630	3630
34	34.000	1.062	373.94	31.876	Std.	1120	1310	2360	2590	2920	3000	3000	3000	3000	3000
					Alt.	1410	1640	2360	2590	2920	3150	3370	3630	3630	3630
34	34.000	1.125	395.36	31.750	Std.	1190	1390	2500	2740	3000	3000	3000	3000	3000	3000
					Alt.	1490	1740	2500	2740	3100	3340	3570	3630	3630	3630
34	34.000	1.188	416.70	31.624	Std.	1260	1470	2640	2890	3000	3000	3000	3000	3000	3000
					Alt.	1570	1830	2640	2890	3270	3520	3630	3630	3630	3630
34	34.000	1.250	437.62	31.500	Std.	1320	1540	2780	3000	3000	3000	3000	3000	3000	3000
					Alt.	1650	1930	2780	3040	3440	3630	3630	3630	3630	3630
36 ^c	36.000	0.250	95.54	35.500	Std.	250	290	530	580	650	700	750	810	880	1000
					Alt.	310	360	530	580	650	700	750	810	880	1000
36 ^c	36.000	0.281	107.30	35.438	Std.	280	330	590	650	730	790	840	910	980	1120
					Alt.	350	410	590	650	730	790	840	910	980	1120
36	36.000	0.312	119.03	35.376	Std.	310	360	660	720	810	870	940	1010	1090	1250
					Alt.	390	460	660	720	810	870	940	1010	1090	1250
36	36.000	0.344	131.12	35.312	Std.	340	400	720	790	890	960	1030	1120	1200	1380
					Alt.	430	500	720	790	890	960	1030	1120	1200	1380
36	36.000	0.375	142.81	35.250	Std.	380	440	790	860	980	1050	1130	1220	1310	1500
					Alt.	470	550	790	860	980	1050	1130	1220	1310	1500
36	36.000	0.406	154.48	35.188	Std.	410	470	850	930	1060	1140	1220	1320	1420	1620
					Alt.	510	590	850	930	1060	1140	1220	1320	1420	1620
36	36.000	0.438	166.51	35.124	Std.	440	510	920	1010	1140	1230	1310	1420	1530	1750
					Alt.	550	640	920	1010	1140	1230	1310	1420	1530	1750
36	36.000	0.469	178.14	35.062	Std.	470	550	980	1080	1220	1310	1410	1520	1640	1880
					Alt.	590	680	980	1080	1220	1310	1410	1520	1640	1880
36	36.000	0.500	189.75	35.000	Std.	500	580	1050	1150	1300	1400	1500	1630	1750	2000
					Alt.	630	730	1050	1150	1300	1400	1500	1630	1750	2000
36	36.000	0.562	212.90	34.876	Std.	560	660	1180	1290	1460	1570	1690	1830	1970	2250
					Alt.	700	820	1180	1290	1460	1570	1690	1830	1970	2250
36	36.000	0.625	236.35	34.750	Std.	630	730	1310	1440	1630	1750	1880	2030	2190	2500
					Alt.	780	910	1310	1440	1630	1750	1880	2030	2190	2500
36	36.000	0.688	259.71	34.624	Std.	690	800	1440	1580	1790	1930	2060	2240	2410	2750
					Alt.	860	1000	1440	1580	1790	1930	2060	2240	2410	2750

Table 6C (Continued)—Plain-end Line Pipe Dimensions, Weights per Unit Length, and Test Pressures for Sizes 6⁵/₈ through 80 (U.S. Customary Units)

(1)	(2)	(3)	(4)	(5)	(6)	(7)	(8)	(9)	(10)	(11)	(12)	(13)	(14)	(15)	
Size	Specified Outside Diameter <i>D</i> (in.)	Specified Wall Thickness <i>t</i> (in.)	Plain-end Weight per Unit Length <i>w_{pe}</i> (lb/ft)	Calculated Inside Diameter ^a <i>d</i> (in.)	Minimum Test Pressure (psi) ^b										
					Grade A	Grade B	Grade X42	Grade X46	Grade X52	Grade X56	Grade X60	Grade X65	Grade X70	Grade X80	
36	36.000	0.750	282.62	34.500	Std.	750	880	1580	1730	1950	2100	2250	2440	2630	3000
					Alt.	940	1090	1580	1730	1950	2100	2250	2440	2630	3000
36	36.000	0.812	305.44	34.376	Std.	810	950	1710	1870	2110	2270	2440	2640	2840	3000
					Alt.	1020	1180	1710	1870	2110	2270	2440	2640	2840	3250
36	36.000	0.875	328.55	34.250	Std.	880	1020	1840	2010	2280	2450	2630	2840	3000	3000
					Alt.	1090	1280	1840	2010	2280	2450	2630	2840	3060	3500
36	36.000	0.938	351.57	34.124	Std.	940	1090	1970	2160	2440	2630	2810	3000	3000	3000
					Alt.	1170	1370	1970	2160	2440	2630	2810	3050	3280	3630
36	36.000	1.000	374.15	34.000	Std.	1000	1170	2100	2300	2600	2800	3000	3000	3000	3000
					Alt.	1250	1460	2100	2300	2600	2800	3000	3250	3500	3630
36	36.000	1.062	396.64	33.876	Std.	1060	1240	2230	2440	2760	2970	3000	3000	3000	3000
					Alt.	1330	1550	2230	2440	2760	2970	3190	3450	3630	3630
36	36.000	1.125	419.42	33.750	Std.	1130	1310	2360	2590	2930	3000	3000	3000	3000	3000
					Alt.	1410	1640	2360	2590	2930	3150	3380	3630	3630	3630
36	36.000	1.188	442.10	33.624	Std.	1190	1390	2490	2730	3000	3000	3000	3000	3000	3000
					Alt.	1490	1730	2490	2730	3090	3330	3560	3630	3630	3630
36	36.000	1.250	464.35	33.500	Std.	1250	1460	2630	2880	3000	3000	3000	3000	3000	3000
					Alt.	1560	1820	2630	2880	3250	3500	3630	3630	3630	3630
38	38.000	0.312	125.70	37.376	Std.	300	340	620	680	770	830	890	960	1030	1180
					Alt.	370	430	620	680	770	830	890	960	1030	1180
38	38.000	0.344	138.47	37.312	Std.	330	380	680	750	850	910	980	1060	1140	1300
					Alt.	410	480	680	750	850	910	980	1060	1140	1300
38	38.000	0.375	150.83	37.250	Std.	360	410	750	820	920	990	1070	1150	1240	1420
					Alt.	440	520	750	820	920	990	1070	1150	1240	1420
38	38.000	0.406	163.16	37.188	Std.	380	450	810	880	1000	1080	1150	1250	1350	1540
					Alt.	480	560	810	880	1000	1080	1150	1250	1350	1540
38	38.000	0.438	175.87	37.124	Std.	410	480	870	950	1080	1160	1240	1350	1450	1660
					Alt.	520	610	870	950	1080	1160	1240	1350	1450	1660
38	38.000	0.469	188.17	37.062	Std.	440	520	930	1020	1160	1240	1330	1440	1560	1780
					Alt.	560	650	930	1020	1160	1240	1330	1440	1560	1780
38	38.000	0.500	200.44	37.000	Std.	470	550	990	1090	1230	1330	1420	1540	1660	1890
					Alt.	590	690	990	1090	1230	1330	1420	1540	1660	1890
38	38.000	0.562	224.92	36.876	Std.	530	620	1120	1220	1380	1490	1600	1730	1860	2130
					Alt.	670	780	1120	1220	1380	1490	1600	1730	1860	2130
38	38.000	0.625	249.71	36.750	Std.	590	690	1240	1360	1540	1660	1780	1920	2070	2370
					Alt.	740	860	1240	1360	1540	1660	1780	1920	2070	2370
38	38.000	0.688	274.42	36.624	Std.	650	760	1370	1500	1690	1830	1960	2120	2280	2610
					Alt.	810	950	1370	1500	1690	1830	1960	2120	2280	2610
38	38.000	0.750	298.65	36.500	Std.	710	830	1490	1630	1850	1990	2130	2310	2490	2840
					Alt.	890	1040	1490	1630	1850	1990	2130	2310	2490	2840
38	38.000	0.812	322.80	36.376	Std.	770	900	1620	1770	2000	2150	2310	2500	2690	3000
					Alt.	960	1120	1620	1770	2000	2150	2310	2500	2690	3080
38	38.000	0.875	347.26	36.250	Std.	830	970	1740	1910	2160	2320	2490	2690	2900	3000
					Alt.	1040	1210	1740	1910	2160	2320	2490	2690	2900	3320
38	38.000	0.938	371.63	36.124	Std.	890	1040	1870	2040	2310	2490	2670	2890	3000	3000
					Alt.	1110	1300	1870	2040	2310	2490	2670	2890	3110	3550
38	38.000	1.000	395.53	36.000	Std.	950	1110	1990	2180	2460	2650	2840	3000	3000	3000
					Alt.	1180	1380	1990	2180	2460	2650	2840	3080	3320	3630
38	38.000	1.062	419.35	35.876	Std.	1010	1170	2110	2310	2620	2820	3000	3000	3000	3000
					Alt.	1260	1470	2110	2310	2620	2820	3020	3270	3520	3630

Table 6C (Continued)—Plain-end Line Pipe Dimensions, Weights per Unit Length, and Test Pressures for Sizes 6⁵/₈ through 80 (U.S. Customary Units)

(1)	(2)	(3)	(4)	(5)	(6) (7) (8) (9) (10) (11) (12) (13) (14) (15)										
Size	Specified Outside Diameter <i>D</i> (in.)	Specified Wall Thickness <i>t</i> (in.)	Plain-end Weight per Unit Length <i>w_{pe}</i> (lb/ft)	Calculated Inside Diameter ^a <i>d</i> (in.)	Minimum Test Pressure (psi) ^b										
					Grade A	Grade B	Grade X42	Grade X46	Grade X52	Grade X56	Grade X60	Grade X65	Grade X70	Grade X80	
38	38.000	1.125	443.47	35.750	Std.	1070	1240	2240	2450	2770	2980	3000	3000	3000	3000
					Alt.	1330	1550	2240	2450	2770	2980	3200	3460	3630	3630
38	38.000	1.188	467.50	35.624	Std.	1130	1310	2360	2590	2930	3000	3000	3000	3000	3000
					Alt.	1410	1640	2360	2590	2930	3150	3380	3630	3630	3630
38	38.000	1.250	491.07	35.500	Std.	1180	1380	2490	2720	3000	3000	3000	3000	3000	3000
					Alt.	1480	1730	2490	2720	3080	3320	3550	3630	3630	3630
40	40.000	0.312	132.37	39.376	Std.	280	330	590	650	730	790	840	910	980	1120
					Alt.	350	410	590	650	730	790	840	910	980	1120
40	40.000	0.344	145.83	39.312	Std.	310	360	650	710	800	870	930	1010	1080	1240
					Alt.	390	450	650	710	800	870	930	1010	1080	1240
40	40.000	0.375	158.85	39.250	Std.	340	390	710	780	880	950	1010	1100	1180	1350
					Alt.	420	490	710	780	880	950	1010	1100	1180	1350
40	40.000	0.406	171.84	39.188	Std.	370	430	770	840	950	1020	1100	1190	1280	1460
					Alt.	460	530	770	840	950	1020	1100	1190	1280	1460
40	40.000	0.438	185.24	39.124	Std.	390	460	830	910	1020	1100	1180	1280	1380	1580
					Alt.	490	570	830	910	1020	1100	1180	1280	1380	1580
40	40.000	0.469	198.19	39.062	Std.	420	490	890	970	1100	1180	1270	1370	1480	1690
					Alt.	530	620	890	970	1100	1180	1270	1370	1480	1690
40	40.000	0.500	211.13	39.000	Std.	450	530	950	1040	1170	1260	1350	1460	1580	1800
					Alt.	560	660	950	1040	1170	1260	1350	1460	1580	1800
40	40.000	0.562	236.93	38.876	Std.	510	590	1060	1160	1320	1420	1520	1640	1770	2020
					Alt.	630	740	1060	1160	1320	1420	1520	1640	1770	2020
40	40.000	0.625	263.07	38.750	Std.	560	660	1180	1290	1460	1580	1690	1830	1970	2250
					Alt.	700	820	1180	1290	1460	1580	1690	1830	1970	2250
40	40.000	0.688	289.13	38.624	Std.	620	720	1300	1420	1610	1730	1860	2010	2170	2480
					Alt.	770	900	1300	1420	1610	1730	1860	2010	2170	2480
40	40.000	0.750	314.69	38.500	Std.	680	790	1420	1550	1760	1890	2030	2190	2360	2700
					Alt.	840	980	1420	1550	1760	1890	2030	2190	2360	2700
40	40.000	0.812	340.16	38.376	Std.	730	850	1530	1680	1900	2050	2190	2380	2560	2920
					Alt.	910	1070	1530	1680	1900	2050	2190	2380	2560	2920
40	40.000	0.875	365.97	38.250	Std.	790	920	1650	1810	2050	2210	2360	2560	2760	3000
					Alt.	980	1150	1650	1810	2050	2210	2360	2560	2760	3150
40	40.000	0.938	391.68	38.124	Std.	840	980	1770	1940	2190	2360	2530	2740	2950	3000
					Alt.	1060	1230	1770	1940	2190	2360	2530	2740	2950	3380
40	40.000	1.000	416.91	38.000	Std.	900	1050	1890	2070	2340	2520	2700	2930	3000	3000
					Alt.	1130	1310	1890	2070	2340	2520	2700	2930	3150	3600
40	40.000	1.062	442.05	37.876	Std.	960	1120	2010	2200	2490	2680	2870	3000	3000	3000
					Alt.	1190	1390	2010	2200	2490	2680	2870	3110	3350	3630
40	40.000	1.125	467.52	37.750	Std.	1010	1180	2130	2330	2630	2840	3000	3000	3000	3000
					Alt.	1270	1480	2130	2330	2630	2840	3040	3290	3540	3630
40	40.000	1.188	492.90	37.624	Std.	1070	1250	2250	2460	2780	2990	3000	3000	3000	3000
					Alt.	1340	1560	2250	2460	2780	2990	3210	3470	3630	3630
40	40.000	1.250	517.80	37.500	Std.	1130	1310	2360	2590	2930	3000	3000	3000	3000	3000
					Alt.	1410	1640	2360	2590	2930	3150	3380	3630	3630	3630
42	42.000	0.344	153.18	41.312	Std.	290	340	620	680	770	830	880	960	1030	1180
					Alt.	370	430	620	680	770	830	880	960	1030	1180
42	42.000	0.375	166.86	41.250	Std.	320	380	680	740	840	900	960	1040	1130	1290
					Alt.	400	470	680	740	840	900	960	1040	1130	1290
42	42.000	0.406	180.52	41.188	Std.	350	410	730	800	900	970	1040	1130	1220	1390
					Alt.	440	510	730	800	900	970	1040	1130	1220	1390

Table 6C (Continued)—Plain-end Line Pipe Dimensions, Weights per Unit Length, and Test Pressures for Sizes 6⁵/₈ through 80 (U.S. Customary Units)

(1) Size	(2) Specified Outside Diameter <i>D</i> (in.)	(3) Specified Wall Thickness <i>t</i> (in.)	(4) Plain-end Weight per Unit Length <i>w_{pe}</i> (lb/ft)	(5) Calculated Inside Diameter ^a <i>d</i> (in.)	(6) through (15) Minimum Test Pressure (psi) ^b										
					Grade										
					A	B	X42	X46	X52	X56	X60	X65	X70	X80	
42	42.000	0.438	194.60	41.124	Std.	380	440	790	860	980	1050	1130	1220	1310	1500
					Alt.	470	550	790	860	980	1050	1130	1220	1310	1500
42	42.000	0.469	208.22	41.062	Std.	400	470	840	920	1050	1130	1210	1310	1410	1610
					Alt.	500	590	840	920	1050	1130	1210	1310	1410	1610
42	42.000	0.500	221.82	41.000	Std.	430	500	900	990	1110	1200	1290	1390	1500	1710
					Alt.	540	630	900	990	1110	1200	1290	1390	1500	1710
42	42.000	0.562	248.95	40.876	Std.	480	560	1010	1110	1250	1350	1450	1570	1690	1930
					Alt.	600	700	1010	1110	1250	1350	1450	1570	1690	1930
42	42.000	0.625	276.44	40.750	Std.	540	630	1130	1230	1390	1500	1610	1740	1880	2140
					Alt.	670	780	1130	1230	1390	1500	1610	1740	1880	2140
42	42.000	0.688	303.84	40.624	Std.	590	690	1240	1360	1530	1650	1770	1920	2060	2360
					Alt.	740	860	1240	1360	1530	1650	1770	1920	2060	2360
42	42.000	0.750	330.72	40.500	Std.	640	750	1350	1480	1670	1800	1930	2090	2250	2570
					Alt.	800	940	1350	1480	1670	1800	1930	2090	2250	2570
42	42.000	0.812	357.52	40.376	Std.	700	810	1460	1600	1810	1950	2090	2260	2440	2780
					Alt.	870	1020	1460	1600	1810	1950	2090	2260	2440	2780
42	42.000	0.875	384.67	40.250	Std.	750	880	1580	1730	1950	2100	2250	2440	2630	3000
					Alt.	940	1090	1580	1730	1950	2100	2250	2440	2630	3000
42	42.000	0.938	411.74	40.124	Std.	800	940	1690	1850	2090	2250	2410	2610	2810	3000
					Alt.	1010	1170	1690	1850	2090	2250	2410	2610	2810	3220
42	42.000	1.000	438.29	40.000	Std.	860	1000	1800	1970	2230	2400	2570	2790	3000	3000
					Alt.	1070	1250	1800	1970	2230	2400	2570	2790	3000	3430
42	42.000	1.062	464.76	39.876	Std.	910	1060	1910	2090	2370	2550	2730	2960	3000	3000
					Alt.	1140	1330	1910	2090	2370	2550	2730	2960	3190	3630
42	42.000	1.125	491.57	39.750	Std.	960	1130	2030	2220	2510	2700	2890	3000	3000	3000
					Alt.	1210	1410	2030	2220	2510	2700	2890	3130	3380	3630
42	42.000	1.188	518.30	39.624	Std.	1020	1190	2140	2340	2650	2850	3000	3000	3000	3000
					Alt.	1270	1490	2140	2340	2650	2850	3050	3310	3560	3630
42	42.000	1.250	544.52	39.500	Std.	1070	1250	2250	2460	2790	3000	3000	3000	3000	3000
					Alt.	1340	1560	2250	2460	2790	3000	3210	3480	3630	3630
44	44.000	0.344	160.54	43.312	Std.	280	330	590	650	730	790	840	910	990	1130
					Alt.	350	410	590	650	730	790	840	910	990	1130
44	44.000	0.375	174.88	43.250	Std.	310	360	640	710	800	860	920	1000	1070	1230
					Alt.	380	450	640	710	800	860	920	1000	1070	1230
44	44.000	0.406	189.20	43.188	Std.	330	390	700	760	860	930	1000	1080	1160	1330
					Alt.	420	480	700	760	860	930	1000	1080	1160	1330
44	44.000	0.438	203.97	43.124	Std.	360	420	750	820	930	1000	1080	1160	1250	1430
					Alt.	450	520	750	820	930	1000	1080	1160	1250	1430
44	44.000	0.469	218.25	43.062	Std.	380	450	810	880	1000	1070	1150	1250	1340	1530
					Alt.	480	560	810	880	1000	1070	1150	1250	1340	1530
44	44.000	0.500	232.51	43.000	Std.	410	480	860	940	1060	1150	1230	1330	1430	1640
					Alt.	510	600	860	940	1060	1150	1230	1330	1430	1640
44	44.000	0.562	260.97	42.876	Std.	460	540	970	1060	1200	1290	1380	1490	1610	1840
					Alt.	570	670	970	1060	1200	1290	1380	1490	1610	1840
44	44.000	0.625	289.80	42.750	Std.	510	600	1070	1180	1330	1430	1530	1660	1790	2050
					Alt.	640	750	1070	1180	1330	1430	1530	1660	1790	2050
44	44.000	0.688	318.55	42.624	Std.	560	660	1180	1290	1460	1580	1690	1830	1970	2250
					Alt.	700	820	1180	1290	1460	1580	1690	1830	1970	2250
44	44.000	0.750	346.76	42.500	Std.	610	720	1290	1410	1600	1720	1840	1990	2150	2450
					Alt.	770	890	1290	1410	1600	1720	1840	1990	2150	2450

Table 6C (Continued)—Plain-end Line Pipe Dimensions, Weights per Unit Length, and Test Pressures for Sizes 6⁵/₈ through 80 (U.S. Customary Units)

(1)	(2)	(3)	(4)	(5)	(6)	(7)	(8)	(9)	(10)	(11)	(12)	(13)	(14)	(15)	
Size	Specified Outside Diameter <i>D</i> (in.)	Specified Wall Thickness <i>t</i> (in.)	Plain-end Weight per Unit Length <i>w_{pe}</i> (lb/ft)	Calculated Inside Diameter ^a <i>d</i> (in.)	Minimum Test Pressure (psi) ^b										
					Grade A	Grade B	Grade X42	Grade X46	Grade X52	Grade X56	Grade X60	Grade X65	Grade X70	Grade X80	
44	44.000	0.812	374.88	42.376	Std.	660	780	1400	1530	1730	1860	1990	2160	2330	2660
					Alt.	830	970	1400	1530	1730	1860	1990	2160	2330	2660
44	44.000	0.875	403.38	42.250	Std.	720	840	1500	1650	1860	2000	2150	2330	2510	2860
					Alt.	890	1040	1500	1650	1860	2000	2150	2330	2510	2860
44	44.000	0.938	431.79	42.124	Std.	770	900	1610	1770	2000	2150	2300	2490	2690	3000
					Alt.	960	1120	1610	1770	2000	2150	2300	2490	2690	3070
44	44.000	1.000	459.67	42.000	Std.	820	950	1720	1880	2130	2290	2450	2660	2860	3000
					Alt.	1020	1190	1720	1880	2130	2290	2450	2660	2860	3270
44	44.000	1.062	487.47	41.876	Std.	870	1010	1820	2000	2260	2430	2610	2820	3000	3000
					Alt.	1090	1270	1820	2000	2260	2430	2610	2820	3040	3480
44	44.000	1.125	515.63	41.750	Std.	920	1070	1930	2120	2390	2580	2760	2990	3000	3000
					Alt.	1150	1340	1930	2120	2390	2580	2760	2990	3220	3630
44	44.000	1.188	543.70	41.624	Std.	970	1130	2040	2240	2530	2720	2920	3000	3000	3000
					Alt.	1220	1420	2040	2240	2530	2720	2920	3160	3400	3630
44	44.000	1.250	571.25	41.500	Std.	1020	1190	2150	2350	2660	2860	3000	3000	3000	3000
					Alt.	1280	1490	2150	2350	2660	2860	3070	3320	3580	3630
46	46.000	0.344	167.89	45.312	Std.	270	310	570	620	700	750	810	870	940	1080
					Alt.	340	390	570	620	700	750	810	870	940	1080
46	46.000	0.375	182.90	45.250	Std.	290	340	620	680	760	820	880	950	1030	1170
					Alt.	370	430	620	680	760	820	880	950	1030	1170
46	46.000	0.406	197.88	45.188	Std.	320	370	670	730	830	890	950	1030	1110	1270
					Alt.	400	460	670	730	830	890	950	1030	1110	1270
46	46.000	0.438	213.33	45.124	Std.	340	400	720	790	890	960	1030	1110	1200	1370
					Alt.	430	500	720	790	890	960	1030	1110	1200	1370
46	46.000	0.469	228.27	45.062	Std.	370	430	770	840	950	1030	1100	1190	1280	1470
					Alt.	460	540	770	840	950	1030	1100	1190	1280	1470
46	46.000	0.500	243.20	45.000	Std.	390	460	820	900	1020	1100	1170	1270	1370	1570
					Alt.	490	570	820	900	1020	1100	1170	1270	1370	1570
46	46.000	0.562	272.98	44.876	Std.	440	510	920	1010	1140	1230	1320	1430	1540	1760
					Alt.	550	640	920	1010	1140	1230	1320	1430	1540	1760
46	46.000	0.625	303.16	44.750	Std.	490	570	1030	1130	1270	1370	1470	1590	1710	1960
					Alt.	610	710	1030	1130	1270	1370	1470	1590	1710	1960
46	46.000	0.688	333.26	44.624	Std.	540	630	1130	1240	1400	1510	1620	1750	1880	2150
					Alt.	670	790	1130	1240	1400	1510	1620	1750	1880	2150
46	46.000	0.750	362.79	44.500	Std.	590	680	1230	1350	1530	1640	1760	1910	2050	2350
					Alt.	730	860	1230	1350	1530	1640	1760	1910	2050	2350
46	46.000	0.812	392.24	44.376	Std.	640	740	1330	1460	1650	1780	1910	2070	2220	2540
					Alt.	790	930	1330	1460	1650	1780	1910	2070	2220	2540
46	46.000	0.875	422.09	44.250	Std.	680	800	1440	1580	1780	1920	2050	2230	2400	2740
					Alt.	860	1000	1440	1580	1780	1920	2050	2230	2400	2740
46	46.000	0.938	451.85	44.124	Std.	730	860	1540	1690	1910	2060	2200	2390	2570	2940
					Alt.	920	1070	1540	1690	1910	2060	2200	2390	2570	2940
46	46.000	1.000	481.05	44.000	Std.	780	910	1640	1800	2030	2190	2350	2540	2740	3000
					Alt.	980	1140	1640	1800	2030	2190	2350	2540	2740	3130
46	46.000	1.062	510.17	43.876	Std.	830	970	1750	1910	2160	2330	2490	2700	2910	3000
					Alt.	1040	1210	1750	1910	2160	2330	2490	2700	2910	3320
46	46.000	1.125	539.68	43.750	Std.	880	1030	1850	2030	2290	2470	2640	2860	3000	3000
					Alt.	1100	1280	1850	2030	2290	2470	2640	2860	3080	3520
46	46.000	1.188	569.10	43.624	Std.	930	1080	1950	2140	2420	2600	2790	3000	3000	3000
					Alt.	1160	1360	1950	2140	2420	2600	2790	3020	3250	3630

Table 6C (Continued)—Plain-end Line Pipe Dimensions, Weights per Unit Length, and Test Pressures for Sizes 6⁵/₈ through 80 (U.S. Customary Units)

(1)	(2)	(3)	(4)	(5)	(6)	(7)	(8)	(9)	(10)	(11)	(12)	(13)	(14)	(15)	
Size	Specified Outside Diameter <i>D</i> (in.)	Specified Wall Thickness <i>t</i> (in.)	Plain-end Weight per Unit Length <i>w_{pe}</i> (lb/ft)	Calculated Inside Diameter ^a <i>d</i> (in.)	Minimum Test Pressure (psi) ^b										
					Grade A	Grade B	Grade X42	Grade X46	Grade X52	Grade X56	Grade X60	Grade X65	Grade X70	Grade X80	
46	46.000	1.250	597.97	43.500	Std.	980	1140	2050	2250	2540	2740	2930	3000	3000	3000
					Alt.	1220	1430	2050	2250	2540	2740	2930	3180	3420	3630
48	48.000	0.344	175.25	47.312	Std.	260	300	540	590	670	720	770	840	900	1030
					Alt.	320	380	540	590	670	720	770	840	900	1030
48	48.000	0.375	190.92	47.250	Std.	280	330	590	650	730	790	840	910	980	1130
					Alt.	350	410	590	650	730	790	840	910	980	1130
48	48.000	0.406	206.56	47.188	Std.	300	360	640	700	790	850	910	990	1070	1220
					Alt.	380	440	640	700	790	850	910	990	1070	1220
48	48.000	0.438	222.70	47.124	Std.	330	380	690	760	850	920	990	1070	1150	1310
					Alt.	410	480	690	760	850	920	990	1070	1150	1310
48	48.000	0.469	238.30	47.062	Std.	350	410	740	810	910	980	1060	1140	1230	1410
					Alt.	440	510	740	810	910	980	1060	1140	1230	1410
48	48.000	0.500	253.89	47.000	Std.	380	440	790	860	980	1050	1130	1220	1310	1500
					Alt.	470	550	790	860	980	1050	1130	1220	1310	1500
48	48.000	0.562	285.00	46.876	Std.	420	490	890	970	1100	1180	1260	1370	1480	1690
					Alt.	530	610	890	970	1100	1180	1260	1370	1480	1690
48	48.000	0.625	316.52	46.750	Std.	470	550	980	1080	1220	1310	1410	1520	1640	1880
					Alt.	590	680	980	1080	1220	1310	1410	1520	1640	1880
48	48.000	0.688	347.97	46.624	Std.	520	600	1080	1190	1340	1440	1550	1680	1810	2060
					Alt.	650	750	1080	1190	1340	1440	1550	1680	1810	2060
48	48.000	0.750	378.83	46.500	Std.	560	660	1180	1290	1460	1580	1690	1830	1970	2250
					Alt.	700	820	1180	1290	1460	1580	1690	1830	1970	2250
48	48.000	0.812	409.61	46.376	Std.	610	710	1280	1400	1580	1710	1830	1980	2130	2440
					Alt.	760	890	1280	1400	1580	1710	1830	1980	2130	2440
48	48.000	0.875	440.80	46.250	Std.	660	770	1380	1510	1710	1840	1970	2130	2300	2630
					Alt.	820	960	1380	1510	1710	1840	1970	2130	2300	2630
48	48.000	0.938	471.90	46.124	Std.	700	820	1480	1620	1830	1970	2110	2290	2460	2810
					Alt.	880	1030	1480	1620	1830	1970	2110	2290	2460	2810
48	48.000	1.000	502.43	46.000	Std.	750	880	1580	1730	1950	2100	2250	2440	2630	3000
					Alt.	940	1090	1580	1730	1950	2100	2250	2440	2630	3000
48	48.000	1.062	532.88	45.876	Std.	800	930	1670	1830	2070	2230	2390	2590	2790	3000
					Alt.	1000	1160	1670	1830	2070	2230	2390	2590	2790	3190
48	48.000	1.125	563.73	45.750	Std.	840	980	1770	1940	2190	2360	2530	2740	2950	3000
					Alt.	1050	1230	1770	1940	2190	2360	2530	2740	2950	3380
48	48.000	1.188	594.50	45.624	Std.	890	1040	1870	2050	2320	2490	2670	2900	3000	3000
					Alt.	1110	1300	1870	2050	2320	2490	2670	2900	3120	3560
48	48.000	1.250	624.70	45.500	Std.	940	1090	1970	2160	2440	2630	2810	3000	3000	3000
					Alt.	1170	1370	1970	2160	2440	2630	2810	3050	3280	3630
52	52.000	0.375	206.95	51.250	Std.	260	300	550	600	680	730	780	840	910	1040
					Alt.	320	380	550	600	680	730	780	840	910	1040
52	52.000	0.406	223.93	51.188	Std.	280	330	590	650	730	790	840	910	980	1120
					Alt.	350	410	590	650	730	790	840	910	980	1120
52	52.000	0.438	241.42	51.124	Std.	300	350	640	700	790	850	910	990	1060	1210
					Alt.	380	440	640	700	790	850	910	990	1060	1210
52	52.000	0.469	258.36	51.062	Std.	320	380	680	750	840	910	970	1060	1140	1300
					Alt.	410	470	680	750	840	910	970	1060	1140	1300
52	52.000	0.500	275.27	51.000	Std.	350	400	730	800	900	970	1040	1130	1210	1380
					Alt.	430	500	730	800	900	970	1040	1130	1210	1380
52	52.000	0.562	309.03	50.876	Std.	390	450	820	890	1010	1090	1170	1260	1360	1560
					Alt.	490	570	820	890	1010	1090	1170	1260	1360	1560

Table 6C (Continued)—Plain-end Line Pipe Dimensions, Weights per Unit Length, and Test Pressures for Sizes 6⁵/₈ through 80 (U.S. Customary Units)

(1)	(2)	(3)	(4)	(5)	(6)	(7)	(8)	(9)	(10)	(11)	(12)	(13)	(14)	(15)	
Size	Specified Outside Diameter <i>D</i> (in.)	Specified Wall Thickness <i>t</i> (in.)	Plain-end Weight per Unit Length <i>w_{pe}</i> (lb/ft)	Calculated Inside Diameter ^a <i>d</i> (in.)	Minimum Test Pressure (psi) ^b										
					Grade A	Grade B	Grade X42	Grade X46	Grade X52	Grade X56	Grade X60	Grade X65	Grade X70	Grade X80	
52	52.000	0.625	343.25	50.750	Std.	430	500	910	1000	1130	1210	1300	1410	1510	1730
					Alt.	540	630	910	1000	1130	1210	1300	1410	1510	1730
52	52.000	0.688	377.39	50.624	Std.	480	560	1000	1100	1240	1330	1430	1550	1670	1910
					Alt.	600	690	1000	1100	1240	1330	1430	1550	1670	1910
52	52.000	0.750	410.90	50.500	Std.	520	610	1090	1190	1350	1450	1560	1690	1820	2080
					Alt.	650	760	1090	1190	1350	1450	1560	1690	1820	2080
52	52.000	0.812	444.33	50.376	Std.	560	660	1180	1290	1460	1570	1690	1830	1970	2250
					Alt.	700	820	1180	1290	1460	1570	1690	1830	1970	2250
52	52.000	0.875	478.21	50.250	Std.	610	710	1270	1390	1580	1700	1820	1970	2120	2420
					Alt.	760	880	1270	1390	1580	1700	1820	1970	2120	2420
52	52.000	0.938	512.01	50.124	Std.	650	760	1360	1490	1690	1820	1950	2110	2270	2600
					Alt.	810	950	1360	1490	1690	1820	1950	2110	2270	2600
52	52.000	1.000	545.19	50.000	Std.	690	810	1450	1590	1800	1940	2080	2250	2420	2770
					Alt.	870	1010	1450	1590	1800	1940	2080	2250	2420	2770
52	52.000	1.062	578.29	49.876	Std.	740	860	1540	1690	1910	2060	2210	2390	2570	2940
					Alt.	920	1070	1540	1690	1910	2060	2210	2390	2570	2940
52	52.000	1.125	611.84	49.750	Std.	780	910	1640	1790	2030	2180	2340	2530	2730	3000
					Alt.	970	1140	1640	1790	2030	2180	2340	2530	2730	3120
52	52.000	1.188	645.30	49.624	Std.	820	960	1730	1890	2140	2300	2470	2670	2880	3000
					Alt.	1030	1200	1730	1890	2140	2300	2470	2670	2880	3290
52	52.000	1.250	678.15	49.500	Std.	870	1010	1820	1990	2250	2420	2600	2810	3000	3000
					Alt.	1080	1260	1820	1990	2250	2420	2600	2810	3030	3460
56	56.000	0.375	222.99	55.250	Std.	240	280	510	550	630	680	720	780	840	960
					Alt.	300	350	510	550	630	680	720	780	840	960
56	56.000	0.406	241.29	55.188	Std.	260	300	550	600	680	730	780	850	910	1040
					Alt.	330	380	550	600	680	730	780	850	910	1040
56	56.000	0.438	260.15	55.124	Std.	280	330	590	650	730	790	840	920	990	1130
					Alt.	350	410	590	650	730	790	840	920	990	1130
56	56.000	0.469	278.41	55.062	Std.	300	350	630	690	780	840	900	980	1060	1210
					Alt.	380	440	630	690	780	840	900	980	1060	1210
56	56.000	0.500	296.65	55.000	Std.	320	380	680	740	840	900	960	1040	1130	1290
					Alt.	400	470	680	740	840	900	960	1040	1130	1290
56	56.000	0.562	333.06	54.876	Std.	360	420	760	830	940	1010	1080	1170	1260	1450
					Alt.	450	530	760	830	940	1010	1080	1170	1260	1450
56	56.000	0.625	369.97	54.750	Std.	400	470	840	920	1040	1130	1210	1310	1410	1610
					Alt.	500	590	840	920	1040	1130	1210	1310	1410	1610
56	56.000	0.688	406.80	54.624	Std.	440	520	930	1020	1150	1240	1330	1440	1550	1770
					Alt.	550	650	930	1020	1150	1240	1330	1440	1550	1770
56	56.000	0.750	442.97	54.500	Std.	480	560	1010	1110	1250	1350	1450	1570	1690	1930
					Alt.	600	700	1010	1110	1250	1350	1450	1570	1690	1930
56	56.000	0.812	479.05	54.376	Std.	520	610	1100	1200	1360	1460	1570	1700	1830	2090
					Alt.	650	760	1100	1200	1360	1460	1570	1700	1830	2090
56	56.000	0.875	515.63	54.250	Std.	560	660	1180	1290	1460	1580	1690	1830	1970	2250
					Alt.	700	820	1180	1290	1460	1580	1690	1830	1970	2250
56	56.000	0.938	552.12	54.124	Std.	600	700	1270	1390	1570	1690	1810	1960	2110	2410
					Alt.	750	880	1270	1390	1570	1690	1810	1960	2110	2410
56	56.000	1.000	587.95	54.000	Std.	640	750	1350	1480	1670	1800	1930	2090	2250	2570
					Alt.	800	940	1350	1480	1670	1800	1930	2090	2250	2570
56	56.000	1.062	623.70	53.876	Std.	680	800	1430	1570	1780	1910	2050	2220	2390	2730
					Alt.	850	1000	1430	1570	1780	1910	2050	2220	2390	2730

Table 6C (Continued)—Plain-end Line Pipe Dimensions, Weights per Unit Length, and Test Pressures for Sizes 6⁵/₈ through 80 (U.S. Customary Units)

(1) Size	(2) Specified Outside Diameter <i>D</i> (in.)	(3) Specified Wall Thickness <i>t</i> (in.)	(4) Plain-end Weight per Unit Length <i>w_{pe}</i> (lb/ft)	(5) Calculated Inside Diameter ^a <i>d</i> (in.)	(6) through (15) Minimum Test Pressure (psi) ^b										
					Grade										
					A	B	X42	X46	X52	X56	X60	X65	X70	X80	
56	56.000	1.125	659.94	53.750	Std.	720	840	1520	1660	1880	2030	2170	2350	2530	2890
					Alt.	900	1050	1520	1660	1880	2030	2170	2350	2530	2890
56	56.000	1.188	696.10	53.624	Std.	760	890	1600	1760	1990	2140	2290	2480	2670	3000
					Alt.	950	1110	1600	1760	1990	2140	2290	2480	2670	3050
56	56.000	1.250	731.60	53.500	Std.	800	940	1690	1850	2090	2250	2410	2610	2810	3000
					Alt.	1000	1170	1690	1850	2090	2250	2410	2610	2810	3210
60	60.000	0.375	239.02	59.250	Std.	230	260	470	520	590	630	680	730	790	900
					Alt.	280	330	470	520	590	630	680	730	790	900
60	60.000	0.406	258.65	59.188	Std.	240	280	510	560	630	680	730	790	850	970
					Alt.	300	360	510	560	630	680	730	790	850	970
60	60.000	0.438	278.88	59.124	Std.	260	310	550	600	680	740	790	850	920	1050
					Alt.	330	380	550	600	680	740	790	850	920	1050
60	60.000	0.469	298.47	59.062	Std.	280	330	590	650	730	790	840	910	980	1130
					Alt.	350	410	590	650	730	790	840	910	980	1130
60	60.000	0.500	318.03	59.000	Std.	300	350	630	690	780	840	900	980	1050	1200
					Alt.	380	440	630	690	780	840	900	980	1050	1200
60	60.000	0.562	357.09	58.876	Std.	340	390	710	780	880	940	1010	1100	1180	1350
					Alt.	420	490	710	780	880	940	1010	1100	1180	1350
60	60.000	0.625	396.70	58.750	Std.	380	440	790	860	980	1050	1130	1220	1310	1500
					Alt.	470	550	790	860	980	1050	1130	1220	1310	1500
60	60.000	0.688	436.22	58.624	Std.	410	480	870	950	1070	1160	1240	1340	1440	1650
					Alt.	520	600	870	950	1070	1160	1240	1340	1440	1650
60	60.000	0.750	475.04	58.500	Std.	450	530	950	1040	1170	1260	1350	1460	1580	1800
					Alt.	560	660	950	1040	1170	1260	1350	1460	1580	1800
60	60.000	0.812	513.77	58.376	Std.	490	570	1020	1120	1270	1360	1460	1580	1710	1950
					Alt.	610	710	1020	1120	1270	1360	1460	1580	1710	1950
60	60.000	0.875	553.04	58.250	Std.	530	610	1100	1210	1370	1470	1580	1710	1840	2100
					Alt.	660	770	1100	1210	1370	1470	1580	1710	1840	2100
60	60.000	0.938	592.23	58.124	Std.	560	660	1180	1290	1460	1580	1690	1830	1970	2250
					Alt.	700	820	1180	1290	1460	1580	1690	1830	1970	2250
60	60.000	1.000	630.71	58.000	Std.	600	700	1260	1380	1560	1680	1800	1950	2100	2400
					Alt.	750	880	1260	1380	1560	1680	1800	1950	2100	2400
60	60.000	1.062	669.11	57.876	Std.	640	740	1340	1470	1660	1780	1910	2070	2230	2550
					Alt.	800	930	1340	1470	1660	1780	1910	2070	2230	2550
60	60.000	1.125	708.05	57.750	Std.	680	790	1420	1550	1760	1890	2030	2190	2360	2700
					Alt.	840	980	1420	1550	1760	1890	2030	2190	2360	2700
60	60.000	1.188	746.90	57.624	Std.	710	830	1500	1640	1850	2000	2140	2320	2490	2850
					Alt.	890	1040	1500	1640	1850	2000	2140	2320	2490	2850
60	60.000	1.250	785.05	57.500	Std.	750	880	1580	1730	1950	2100	2250	2440	2630	3000
					Alt.	940	1090	1580	1730	1950	2100	2250	2440	2630	3000
64	64.000	0.375	255.06	63.250	Std.	210	250	440	490	550	590	630	690	740	840
					Alt.	260	310	440	490	550	590	630	690	740	840
64	64.000	0.406	276.01	63.188	Std.	230	270	480	530	590	640	690	740	800	910
					Alt.	290	330	480	530	590	640	690	740	800	910
64	64.000	0.438	297.61	63.124	Std.	250	290	520	570	640	690	740	800	860	990
					Alt.	310	360	520	570	640	690	740	800	860	990
64	64.000	0.469	318.52	63.062	Std.	260	310	550	610	690	740	790	860	920	1060
					Alt.	330	380	550	610	690	740	790	860	920	1060
64	64.000	0.500	339.41	63.000	Std.	280	330	590	650	730	790	840	910	980	1130
					Alt.	350	410	590	650	730	790	840	910	980	1130

Table 6C (Continued)—Plain-end Line Pipe Dimensions, Weights per Unit Length, and Test Pressures for Sizes 6⁵/₈ through 80 (U.S. Customary Units)

(1)	(2)	(3)	(4)	(5)	(6)	(7)	(8)	(9)	(10)	(11)	(12)	(13)	(14)	(15)	
Size	Specified Outside Diameter <i>D</i> (in.)	Specified Wall Thickness <i>t</i> (in.)	Plain-end Weight per Unit Length <i>w_{pe}</i> (lb/ft)	Calculated Inside Diameter ^a <i>d</i> (in.)	Minimum Test Pressure (psi) ^b										
					Grade A	Grade B	Grade X42	Grade X46	Grade X52	Grade X56	Grade X60	Grade X65	Grade X70	Grade X80	
64	64.000	0.562	381.12	62.876	Std.	320	370	660	730	820	890	950	1030	1110	1260
					Alt.	400	460	660	730	820	890	950	1030	1110	1260
64	64.000	0.625	423.42	62.750	Std.	350	410	740	810	910	980	1050	1140	1230	1410
					Alt.	440	510	740	810	910	980	1050	1140	1230	1410
64	64.000	0.688	465.64	62.624	Std.	390	450	810	890	1010	1080	1160	1260	1350	1550
					Alt.	480	560	810	890	1010	1080	1160	1260	1350	1550
64	64.000	0.750	507.11	62.500	Std.	420	490	890	970	1100	1180	1270	1370	1480	1690
					Alt.	530	620	890	970	1100	1180	1270	1370	1480	1690
64	64.000	0.812	548.49	62.376	Std.	460	530	960	1050	1190	1280	1370	1480	1600	1830
					Alt.	570	670	960	1050	1190	1280	1370	1480	1600	1830
64	64.000	0.875	590.46	62.250	Std.	490	570	1030	1130	1280	1380	1480	1600	1720	1970
					Alt.	620	720	1030	1130	1280	1380	1480	1600	1720	1970
64	64.000	0.938	632.34	62.124	Std.	530	620	1110	1210	1370	1480	1580	1710	1850	2110
					Alt.	660	770	1110	1210	1370	1480	1580	1710	1850	2110
64	64.000	1.000	673.47	62.000	Std.	560	660	1180	1290	1460	1580	1690	1830	1970	2250
					Alt.	700	820	1180	1290	1460	1580	1690	1830	1970	2250
64	64.000	1.062	714.52	61.876	Std.	600	700	1250	1370	1550	1670	1790	1940	2090	2390
					Alt.	750	870	1250	1370	1550	1670	1790	1940	2090	2390
64	64.000	1.125	756.15	61.750	Std.	630	740	1330	1460	1650	1770	1900	2060	2210	2530
					Alt.	790	920	1330	1460	1650	1770	1900	2060	2210	2530
64	64.000	1.188	797.69	61.624	Std.	670	780	1400	1540	1740	1870	2000	2170	2340	2670
					Alt.	840	970	1400	1540	1740	1870	2000	2170	2340	2670
64	64.000	1.250	838.50	61.500	Std.	700	820	1480	1620	1830	1970	2110	2290	2460	2810
					Alt.	880	1030	1480	1620	1830	1970	2110	2290	2460	2810
68	68.000	0.469	338.57	67.062	Std.	250	290	520	570	650	700	740	810	870	990
					Alt.	310	360	520	570	650	700	740	810	870	990
68	68.000	0.500	360.79	67.000	Std.	260	310	560	610	690	740	790	860	930	1060
					Alt.	330	390	560	610	690	740	790	860	930	1060
68	68.000	0.562	405.15	66.876	Std.	300	350	620	680	770	830	890	970	1040	1190
					Alt.	370	430	620	680	770	830	890	970	1040	1190
68	68.000	0.625	450.15	66.750	Std.	330	390	690	760	860	930	990	1080	1160	1320
					Alt.	410	480	690	760	860	930	990	1080	1160	1320
68	68.000	0.688	495.06	66.624	Std.	360	420	760	840	950	1020	1090	1180	1270	1460
					Alt.	460	530	760	840	950	1020	1090	1180	1270	1460
68	68.000	0.750	539.18	66.500	Std.	400	460	830	910	1030	1110	1190	1290	1390	1590
					Alt.	500	580	830	910	1030	1110	1190	1290	1390	1590
68	68.000	0.812	583.21	66.376	Std.	430	500	900	990	1120	1200	1290	1400	1500	1720
					Alt.	540	630	900	990	1120	1200	1290	1400	1500	1720
68	68.000	0.875	627.87	66.250	Std.	460	540	970	1070	1200	1300	1390	1510	1620	1850
					Alt.	580	680	970	1070	1200	1300	1390	1510	1620	1850
68	68.000	0.938	672.45	66.124	Std.	500	580	1040	1140	1290	1390	1490	1610	1740	1990
					Alt.	620	720	1040	1140	1290	1390	1490	1610	1740	1990
68	68.000	1.000	716.23	66.000	Std.	530	620	1110	1220	1380	1480	1590	1720	1850	2120
					Alt.	660	770	1110	1220	1380	1480	1590	1720	1850	2120
68	68.000	1.062	759.93	65.876	Std.	560	660	1180	1290	1460	1570	1690	1830	1970	2250
					Alt.	700	820	1180	1290	1460	1570	1690	1830	1970	2250
68	68.000	1.125	804.26	65.750	Std.	600	690	1250	1370	1550	1670	1790	1940	2080	2380
					Alt.	740	870	1250	1370	1550	1670	1790	1940	2080	2380
68	68.000	1.188	848.49	65.624	Std.	630	730	1320	1450	1640	1760	1890	2040	2200	2520
					Alt.	790	920	1320	1450	1640	1760	1890	2040	2200	2520

Table 6C (Continued)—Plain-end Line Pipe Dimensions, Weights per Unit Length, and Test Pressures for Sizes 6⁵/₈ through 80 (U.S. Customary Units)

(1) Size	(2) Specified Outside Diameter <i>D</i> (in.)	(3) Specified Wall Thickness <i>t</i> (in.)	(4) Plain-end Weight per Unit Length <i>w_{pe}</i> (lb/ft)	(5) Calculated Inside Diameter ^a <i>d</i> (in.)	(6) through (15) Minimum Test Pressure (psi) ^b										
					Grade										
					A	B	X42	X46	X52	X56	X60	X65	X70	X80	
68	68.000	1.250	891.95	65.500	Std.	660	770	1390	1520	1720	1850	1990	2150	2320	2650
					Alt.	830	970	1390	1520	1720	1850	1990	2150	2320	2650
72	72.000	0.500	382.17	71.000	Std.	250	290	530	580	650	700	750	810	880	1000
					Alt.	310	360	530	580	650	700	750	810	880	1000
72	72.000	0.562	429.18	70.876	Std.	280	330	590	650	730	790	840	910	980	1120
					Alt.	350	410	590	650	730	790	840	910	980	1120
72	72.000	0.625	476.87	70.750	Std.	310	360	660	720	810	880	940	1020	1090	1250
					Alt.	390	460	660	720	810	880	940	1020	1090	1250
72	72.000	0.688	524.48	70.624	Std.	340	400	720	790	890	960	1030	1120	1200	1380
					Alt.	430	500	720	790	890	960	1030	1120	1200	1380
72	72.000	0.750	571.25	70.500	Std.	380	440	790	860	980	1050	1130	1220	1310	1500
					Alt.	470	550	790	860	980	1050	1130	1220	1310	1500
72	72.000	0.812	617.93	70.376	Std.	410	470	850	930	1060	1140	1220	1320	1420	1620
					Alt.	510	590	850	930	1060	1140	1220	1320	1420	1620
72	72.000	0.875	665.29	70.250	Std.	440	510	920	1010	1140	1230	1310	1420	1530	1750
					Alt.	550	640	920	1010	1140	1230	1310	1420	1530	1750
72	72.000	0.938	712.55	70.124	Std.	470	550	980	1080	1220	1310	1410	1520	1640	1880
					Alt.	590	680	980	1080	1220	1310	1410	1520	1640	1880
72	72.000	1.000	758.99	70.000	Std.	500	580	1050	1150	1300	1400	1500	1630	1750	2000
					Alt.	630	730	1050	1150	1300	1400	1500	1630	1750	2000
72	72.000	1.062	805.34	69.876	Std.	530	620	1120	1220	1380	1490	1590	1730	1860	2120
					Alt.	660	770	1120	1220	1380	1490	1590	1730	1860	2120
72	72.000	1.125	852.36	69.750	Std.	560	660	1180	1290	1460	1580	1690	1830	1970	2250
					Alt.	700	820	1180	1290	1460	1580	1690	1830	1970	2250
72	72.000	1.188	899.29	69.624	Std.	590	690	1250	1370	1540	1660	1780	1930	2080	2380
					Alt.	740	870	1250	1370	1540	1660	1780	1930	2080	2380
72	72.000	1.250	945.40	69.500	Std.	630	730	1310	1440	1630	1750	1880	2030	2190	2500
					Alt.	780	910	1310	1440	1630	1750	1880	2030	2190	2500
76	76.000	0.500	403.55	75.000	Std.	240	280	500	540	620	660	710	770	830	950
					Alt.	300	350	500	540	620	660	710	770	830	950
76	76.000	0.562	453.21	74.876	Std.	270	310	560	610	690	750	800	870	930	1060
					Alt.	330	390	560	610	690	750	800	870	930	1060
76	76.000	0.625	503.60	74.750	Std.	300	350	620	680	770	830	890	960	1040	1180
					Alt.	370	430	620	680	770	830	890	960	1040	1180
76	76.000	0.688	553.90	74.624	Std.	330	380	680	750	850	910	980	1060	1140	1300
					Alt.	410	480	680	750	850	910	980	1060	1140	1300
76	76.000	0.750	603.32	74.500	Std.	360	410	750	820	920	990	1070	1150	1240	1420
					Alt.	440	520	750	820	920	990	1070	1150	1240	1420
76	76.000	0.812	652.65	74.376	Std.	380	450	810	880	1000	1080	1150	1250	1350	1540
					Alt.	480	560	810	880	1000	1080	1150	1250	1350	1540
76	76.000	0.875	702.70	74.250	Std.	410	480	870	950	1080	1160	1240	1350	1450	1660
					Alt.	520	600	870	950	1080	1160	1240	1350	1450	1660
76	76.000	0.938	752.66	74.124	Std.	440	520	930	1020	1160	1240	1330	1440	1560	1780
					Alt.	560	650	930	1020	1160	1240	1330	1440	1560	1780
76	76.000	1.000	801.75	74.000	Std.	470	550	990	1090	1230	1330	1420	1540	1660	1890
					Alt.	590	690	990	1090	1230	1330	1420	1540	1660	1890
76	76.000	1.062	850.75	73.876	Std.	500	590	1060	1160	1310	1410	1510	1630	1760	2010
					Alt.	630	730	1060	1160	1310	1410	1510	1630	1760	2010
76	76.000	1.125	900.47	73.750	Std.	530	620	1120	1230	1390	1490	1600	1730	1870	2130
					Alt.	670	780	1120	1230	1390	1490	1600	1730	1870	2130

Table 6C (Continued)—Plain-end Line Pipe Dimensions, Weights per Unit Length, and Test Pressures for Sizes 6⁵/₈ through 80 (U.S. Customary Units)

(1)	(2)	(3)	(4)	(5)	(6)	(7)	(8)	(9)	(10)	(11)	(12)	(13)	(14)	(15)	
Size	Specified Outside Diameter <i>D</i> (in.)	Specified Wall Thickness <i>t</i> (in.)	Plain-end Weight per Unit Length <i>w_{pe}</i> (lb/ft)	Calculated Inside Diameter ^a <i>d</i> (in.)	Minimum Test Pressure (psi) ^b										
					Grade A	Grade B	Grade X42	Grade X46	Grade X52	Grade X56	Grade X60	Grade X65	Grade X70	Grade X80	
76	76.000	1.188	950.09	73.624	Std.	560	660	1180	1290	1460	1580	1690	1830	1970	2250
					Alt.	700	820	1180	1290	1460	1580	1690	1830	1970	2250
76	76.000	1.250	998.85	73.500	Std.	590	690	1240	1360	1540	1660	1780	1920	2070	2370
					Alt.	740	860	1240	1360	1540	1660	1780	1920	2070	2370
80	80.000	0.562	477.25	78.876	Std.	250	300	530	580	660	710	760	820	890	1010
					Alt.	320	370	530	580	660	710	760	820	890	1010
80	80.000	0.625	530.32	78.750	Std.	280	330	590	650	730	790	840	910	980	1130
					Alt.	350	410	590	650	730	790	840	910	980	1130
80	80.000	0.688	583.32	78.624	Std.	310	360	650	710	800	870	930	1010	1080	1240
					Alt.	390	450	650	710	800	870	930	1010	1080	1240
80	80.000	0.750	635.39	78.500	Std.	340	390	710	780	880	950	1010	1100	1180	1350
					Alt.	420	490	710	780	880	950	1010	1100	1180	1350
80	80.000	0.812	687.37	78.376	Std.	370	430	770	840	950	1020	1100	1190	1280	1460
					Alt.	460	530	770	840	950	1020	1100	1190	1280	1460
80	80.000	0.875	740.12	78.250	Std.	390	460	830	910	1020	1100	1180	1280	1380	1580
					Alt.	490	570	830	910	1020	1100	1180	1280	1380	1580
80	80.000	0.938	792.77	78.124	Std.	420	490	890	970	1100	1180	1270	1370	1480	1690
					Alt.	530	620	890	970	1100	1180	1270	1370	1480	1690
80	80.000	1.000	844.51	78.000	Std.	450	530	950	1040	1170	1260	1350	1460	1580	1800
					Alt.	560	660	950	1040	1170	1260	1350	1460	1580	1800
80	80.000	1.062	896.17	77.876	Std.	480	560	1000	1100	1240	1340	1430	1550	1670	1910
					Alt.	600	700	1000	1100	1240	1340	1430	1550	1670	1910
80	80.000	1.125	948.57	77.750	Std.	510	590	1060	1160	1320	1420	1520	1650	1770	2030
					Alt.	630	740	1060	1160	1320	1420	1520	1650	1770	2030
80	80.000	1.188	1000.89	77.624	Std.	530	620	1120	1230	1390	1500	1600	1740	1870	2140
					Alt.	670	780	1120	1230	1390	1500	1600	1740	1870	2140
80	80.000	1.250	1052.30	77.500	Std.	560	660	1180	1290	1460	1580	1690	1830	1970	2250
					Alt.	700	820	1180	1290	1460	1580	1690	1830	1970	2250

Note: See Table E-6C for SI unit values corresponding to the U.S. Customary unit values given in this table.

^aThe calculated inside diameters are given here for information (see 7.2).

^bThe test pressures given in Tables 6A, 6B, and 6C apply to Grades A25, A, B, X42, X46, X52, X56, X60, X65, X70, and X80 only. See 9.4.3 for pressures applicable to other grades.

^cPipe that has this combination of specified outside diameter and specified wall thickness is special plain-end pipe; other combinations given in this table are regular plain-end pipe. Pipe that has a combination of specified outside diameter and specified wall thickness that is intermediate to the tabulated values is considered to be special plain-end pipe if the next lower tabulated value is for special plain-end pipe; other intermediate combinations are considered to be regular plain-end pipe. (See Table 10 for the applicable weight tolerances.)

Table 7—Tolerances for Diameter of Pipe Body

Size	Tolerance ^a (with respect to specified outside diameter)
< 2 ³ / ₈	+ 0.016 in., - 0.031 in. (+ 0.41 mm, - 0.8 mm)
≥ 2 ³ / ₈ and ≤ 4 ¹ / ₂ , continuous welded	± 1.00%
≥ 2 ³ / ₈ and < 20	± 0.75%
≥ 20, seamless	± 1.00%
≥ 20 and ≤ 36, welded	+ 0.75%, - 0.25%
> 36, welded	+ ¹ / ₄ in., - ¹ / ₈ in. (+ 6.4 mm, - 3.2 mm)

^aIn the case of pipe hydrostatically tested to pressures in excess of standard test pressures, other tolerances may be agreed upon between the manufacturer and the purchaser.

Table 8—Tolerance for Diameter at Pipe Ends

Size	Minus Tolerance	Plus Tolerance	End-to-End Tolerance	Out-of-Roundness	
				Diameter, Axis Tolerance (Percent of Specified OD) ^a	Maximum Differential Between Minimum and Maximum Diameters (Applies only to Pipe with $D/t \leq 75$)
≤ 10 ³ / ₄	¹ / ₆₄ (0.4 mm)	¹ / ₁₆ (1.6 mm)	—	—	—
> 10 ³ / ₄ and ≤ 20	¹ / ₃₂ (0.8 mm)	³ / ₃₂ (2.4 mm)	—	—	—
> 20 and ≤ 42	¹ / ₃₂ (0.8 mm)	³ / ₃₂ (2.4 mm)	b	± 1%	≤ 0.500 in. (12.7 mm)
> 42	¹ / ₃₂ (0.8 mm)	³ / ₃₂ (2.4 mm)	b	± 1%	≤ 0.625 in. (15.9 mm)

^aOut-of-roundness tolerances apply to maximum and minimum diameters as measured with a bar gage, caliper, or device measuring actual maximum and minimum diameters.

^bThe average diameter (as measured with a diameter tape) of one end of pipe shall not differ by more than ³/₃₂ in. (2.4 mm) from that of the other end.

Table 9—Tolerances for Wall Thickness

Size	Type of Pipe	Tolerance ^a (Percent of Specified Wall Thickness)	
		Grade B or Lower	Grade X42 or Higher
≤ 2 ⁷ / ₈	All	+ 20.0, - 12.5	+ 15.0, - 12.5
> 2 ⁷ / ₈ and < 20	All	+ 15.0, - 12.5	+ 15.0, - 12.5
≥ 20	Welded	+ 17.5, - 12.5	+ 19.5, - 8.0
≥ 20	Seamless	+ 15.0, - 12.5	+ 17.5, - 10.0

^aWhere negative tolerances smaller than those listed are specified by the purchaser, the positive tolerance shall be increased to the applicable total tolerance range in percent less the wall thickness negative tolerance.

Table 10—Tolerances for Weight

Quantity	Tolerance (percent)
Single lengths, special plain-end pipe or A25 pipe	+ 10, - 5.0
Single lengths, other pipe	+ 10, - 3.5
Carloads, Grade A25, 40,000 lb (18 144 kg) or more	- 2.5
Carloads, other than Grade A25, 40,000 lb (18 144 kg) or more	- 1.75
Carloads, all grades, less than 40,000 lb (18 144 kg)	- 3.5
Order items, Grade A25, 40,000 lb (18 144 kg) or more	- 3.5
Order items, other than Grade A25, 40,000 lb (18 144 kg) or more	- 1.75
Order items, all grades, less than 40,000 lb (18 144 kg)	- 3.5

Notes:

1. Weight tolerances apply to the calculated weights for threaded-and-coupled pipe and to the tabulated or calculated weights for plain-end pipe. Where negative wall thickness tolerances smaller than those listed in Table 9 are specified by the purchaser, the plus weight tolerance for single lengths shall be increased to 22.5% less the wall thickness negative tolerance.

2. For carloads composed of pipe from more than one order item, the carload tolerances are to be applied on an individual order item basis.

3. The tolerances for order items apply to the overall quantity of pipe shipped for the order item.

Table 11—Tolerances on Lengths

Nominal Length ^a		Minimum Length		Minimum Average Length for Each Order Item ^b		Maximum Length	
ft	m	ft	m	ft	m	ft	m
Threaded-and-coupled Pipe							
20	6	16.0	4.88	17.5	5.33	22.5	6.86
40	12	22.0	6.71	35.0	10.67	45.0	13.72
Plain-end Pipe							
20	6	9.0	2.74	17.5	5.33	22.5	6.86
40	12	14.0	4.27	35.0	10.67	45.0	13.72
50	15	17.5	5.33	43.8	13.35	55.0	16.76
60	18	21.0	6.40	52.5	16.00	65.0	19.81
80	24	28.0	8.53	70.0	21.34	85.0	25.91

^aNominal lengths of 20 ft (6 m) were formerly designated "single random lengths" and those of 40 ft (12 m) "double random lengths."

^bBy agreement between the purchaser and the manufacturer, these tolerances shall apply to each carload.

Table 12—Coupling Dimensions, Weights, and Tolerances

(1) Size	(2) Specified Outside Diameter of Coupling, ^a <i>W</i>		(3) Specified Minimum Length, <i>N_L</i>		(4) Specified Diameter of Recess, <i>Q</i>		(5) Specified Width of Bearing Face, <i>b</i>		(6) Calculated Coupling Weight	
	in.	mm	in.	mm	in.	mm	in.	mm	lb	kg
0.405	0.563	14.3	1 ¹ / ₁₆	27.0	0.468	11.9	1 ¹ / ₃₂	0.8	0.04	0.02
0.540	0.719	18.3	1 ⁵ / ₈	41.3	0.603	15.3	1 ¹ / ₃₂	0.8	0.09	0.04
0.675	0.875	22.2	1 ⁵ / ₈	41.3	0.738	18.8	1 ¹ / ₃₂	0.8	0.13	0.06
0.840	1.063	27.0	2 ¹ / ₈	54.0	0.903	22.9	1 ¹ / ₁₆	1.6	0.24	0.11
1.050	1.313	33.4	2 ¹ / ₈	54.0	1.113	28.3	1 ¹ / ₁₆	1.6	0.34	0.15
1.315	1.576	40.0	2 ⁵ / ₈	66.7	1.378	35.0	3 ¹ / ₃₂	2.4	0.54	0.25
1.660	2.054	52.2	2 ³ / ₄	69.8	1.723	43.8	3 ¹ / ₃₂	2.4	1.03	0.47
1.900	2.200	55.9	2 ³ / ₄	69.8	1.963	49.9	3 ¹ / ₃₂	2.4	0.90	0.41
2 ³ / ₈	2.875	73.0	2 ⁷ / ₈	73.0	2.469	62.7	1 ¹ / ₈	3.2	1.86	0.84
2 ⁷ / ₈	3.375	85.7	4 ¹ / ₈	104.8	2.969	75.4	3 ¹ / ₁₆	4.8	3.27	1.48
3 ¹ / ₂	4.000	101.6	4 ¹ / ₄	108.0	3.594	91.3	3 ¹ / ₁₆	4.8	4.09	1.86
4	4.625	117.5	4 ³ / ₈	111.1	4.094	104.0	3 ¹ / ₁₆	4.8	5.92	2.69
4 ¹ / ₂	5.200	132.1	4 ¹ / ₂	114.3	4.594	116.7	1 ¹ / ₄	6.4	7.60	3.45
5 ⁹ / ₁₆	6.296	159.9	4 ⁵ / ₈	117.5	5.657	143.7	1 ¹ / ₄	6.4	9.99	4.53
6 ⁵ / ₈	7.390	187.7	4 ⁷ / ₈	123.8	6.719	170.7	1 ¹ / ₄	6.4	12.93	5.87
8 ⁵ / ₈	9.625	244.5	5 ¹ / ₄	133.4	8.719	221.5	1 ¹ / ₄	6.4	23.20	10.52
10 ³ / ₄	11.750	298.4	5 ³ / ₄	146.0	10.844	275.4	3 ¹ / ₈	9.5	31.58	14.32
12 ³ / ₄	14.000	355.6	6 ¹ / ₈	155.6	12.844	326.2	3 ¹ / ₈	9.5	49.32	22.37
14	15.000	381.0	6 ³ / ₈	161.9	14.094	358.0	3 ¹ / ₈	9.5	45.88	20.81
16	17.000	431.8	6 ³ / ₄	171.4	16.094	408.8	3 ¹ / ₈	9.5	55.89	23.35
18	19.000	482.6	7 ¹ / ₈	181.0	18.094	459.6	3 ¹ / ₈	9.5	66.61	30.20
20	21.000	533.4	7 ⁵ / ₈	193.7	20.094	510.4	3 ¹ / ₈	9.5	79.45	36.03

Note: See Figure 2.

^aTolerance on outside diameter, *W*, is $\pm 1\%$.

Table 13—Maximum Inspection Lot Size for Tensile Testing

(1)	(2)	(3)	(4)	(5)	(6)
Maximum Inspection Lot ^a Size					
Longitudinal or Transverse			Weld Tensile Tests		
Pipe Size	Type of Pipe	Grade	Tensile Test	Long. or Helical Seam Weld	Skelp End Weld
≤ 1.900	Welded	A25	25 tons (25 Mg)	—	—
> 1.900	Welded	A25	50 tons (50 Mg)	—	—
≤ 5 ⁹ / ₁₆	Welded	> A25	400 lengths ^b	—	—
≤ 5 ⁹ / ₁₆	Seamless	All	400 lengths ^b	—	—
> 5 ⁹ / ₁₆ and < 8 ⁵ / ₈	All	All	200 lengths per heat	—	—
≥ 8 ⁵ / ₈ through 12 ³ / ₄	All	All	200 lengths per heat per cold expansion percentage ^c	200 lengths per heat per cold expansion percentage ^{c, d}	200 lengths per cold expansion percentage ^{c, d, f}
> 12 ³ / ₄	All	All	100 lengths per heat per cold expansion percentage ^c	100 lengths per heat per cold expansion percentage ^{c, d, e}	100 lengths per cold expansion percentage ^{c, d, f}

^aInspection lots consist of pipe that are made to the same size and the same specified wall thickness by the same process and under the same manufacturing conditions.

^bIn addition, over the duration of the pipe production run, each heat of steel is to be tested at least once.

^cThe cold expansion percentage is designated by the manufacturer, and is derived using the designated before-expansion outside diameter or circumference and the designated after-expansion outside diameter or circumference. An increase or decrease in the cold expansion percentage of more than 0.2 percentage point (for example, a change from 1.0% cold expansion to < 0.8% or > 1.2%) constitutes a change in inspection lot.

^dIn addition, over the duration of the pipe production run, pipe produced by each welding machine is to be tested at least once per week.

^eFor each test of double seam pipe, both weld seams in the pipe selected to represent the inspection lot are to be tested.

^fApplies only to finished helical seam pipe containing skelp end welds.

Note: The test frequency is one test per inspection lot. (See 9.3.1.2.)

Table 14—Relationship between Pipe Dimensions and Required Charpy Specimens

Size	Specified Wall Thickness, in. (mm)				
	Full Size Transverse	2/3 Size Transverse	1/2 Size Transverse	2/3 Size Longitudinal	1/2 Size Longitudinal
≥ 4 ¹ / ₂ and < 5 ⁹ / ₁₆	≥ 0.495 (12.6)	0.429 – 0.494 (10.9 – 12.5)	0.397 – 0.428 (10.1 – 10.8)	0.312 – 0.396 (7.9 – 10.0)	0.246 – 0.311 (6.2 – 7.8)
≥ 5 ⁹ / ₁₆ and < 6 ⁵ / ₈	≥ 0.469 (11.9)	0.371 – 0.468 (9.4 – 11.8)	0.338 – 0.370 (8.6 – 9.3)	0.310 – 0.337 (7.9 – 9.2)	0.245 – 0.309 (6.2 – 7.8)
≥ 6 ⁵ / ₈ and < 8 ⁵ / ₈	≥ 0.460 (11.7)	0.334 – 0.459 (8.6 – 11.6)	0.301 – 0.333 (7.6 – 8.4)		0.244 – 0.300 (6.2 – 7.5)
≥ 8 ⁵ / ₈ and < 10 ³ / ₄	≥ 0.450 (11.4)	0.318 – 0.449 (8.1 – 11.3)	0.257 – 0.317 (6.5 – 8.0)		0.242 – 0.256 (6.1 – 6.4)
≥ 10 ³ / ₄ and < 12 ³ / ₄	≥ 0.443 (11.3)	0.311 – 0.442 (7.9 – 11.2)	0.246 – 0.310 (6.2 – 7.8)		0.241 – 0.245 (6.1)
≥ 12 ³ / ₄ and < 14	≥ 0.438 (11.1)	0.307 – 0.437 (7.8 – 11.0)	0.241 – 0.306 (6.1 – 7.7)		
≥ 14 and < 16	≥ 0.436 (11.1)	0.305 – 0.435 (7.7 – 11.0)	0.239 – 0.304 (6.1 – 7.6)		
≥ 16	≥ 0.434 (11.0)	0.304 – 0.433 (7.7 – 10.9)	0.237 – 0.303 (6.0 – 7.6)		

Notes:

1. This table provides a description of the required specimens and the relationship between pipe dimensions and acceptable specimens. The size limits for transverse specimens shown are based upon the use of nonflattened, tapered end, test specimens.
2. All specimen dimension limits include machining tolerances.
3. Pipe in size and specified wall thickness combinations not covered by this table are not required to be tested.

Table 14A—Relationship between Pipe Dimensions and Transverse Tensile Specimens

Size	Minimum Wall Thickness, in. (mm)		
	0.500 (12.7 mm) Specimen	0.350 (8.9 mm) Specimen	0.250 (6.4 mm) Specimen
$\geq 8^{5/8}$ and $< 10^{3/4}$	—	—	0.670 – 1.000 (17.0 – 25.4)
$\geq 10^{3/4}$ and $< 12^{3/4}$	—	1.031 – 1.250 (26.2 – 31.8)	0.620 – 1.030 (15.7 – 26.1)
$\geq 12^{3/4}$ and < 14	—	0.961 – 1.250 (23.7 – 31.8)	0.590 – 0.960 (15.0 – 24.3)
≥ 14 and < 16	—	0.931 – 1.250 (23.7 – 31.8)	0.580 – 0.930 (14.7 – 23.6)
≥ 16 and < 18	≥ 1.191 (30.2)	0.891 – 1.190 (22.6 – 30.2)	0.560 – 0.890 (14.2 – 22.5)
≥ 18 and < 20	≥ 1.141 (29.0)	0.871 – 1.140 (22.1 – 28.9)	0.550 – 0.870 (14.0 – 22.0)
≥ 20 and < 22	≥ 1.111 (28.2)	0.841 – 1.110 (21.4 – 28.1)	0.530 – 0.840 (13.5 – 21.3)
≥ 22 and < 24	≥ 1.081 (27.4)	0.821 – 1.080 (20.8 – 27.3)	0.530 – 0.820 (13.5 – 20.7)
≥ 24 and < 26	≥ 1.051 (26.7)	0.811 – 1.050 (20.6 – 26.6)	0.520 – 0.810 (13.2 – 20.5)
≥ 26 and < 28	≥ 1.031 (26.2)	0.791 – 1.030 (20.1 – 26.1)	0.510 – 0.790 (13.0 – 20.0)
≥ 28	≥ 1.021 (25.9)	0.781 – 1.020 (19.8 – 25.8)	0.510 – 0.780 (13.0 – 19.7)

Notes:

- Dimensions are based on a total specimen length of 5 in. (125 mm), 4 in. (100 mm) and 2.75 in. (70 mm) for the 0.500 (12.7 mm), 0.350 in. (8.9 mm), and 0.250 in. (6.4 mm) specimens, respectively.
- For pipe sizes too small to obtain a 0.250 in. (6.4 mm) specimen, round bar tensile test specimens shall not be used.

Table 15—ASTM Hole-type IQI for Fluoroscopic Inspection

(1)		(2)		(3)		(4)	(5)
Weld Thickness ^a							
Over		Through		IQI Thickness		IQI Designation	Essential Hole
in.	mm	in.	mm	in.	mm		
—	—	$5/16$	8	0.0125	0.32	12	4T
$5/16$	8	$7/16$	11	0.0150	0.38	15	4T
$7/16$	11	$9/16$	14	0.0175	0.44	17	4T
$9/16$	14	$11/16$	18	0.0200	0.51	20	4T
$11/16$	18	1	25	0.0250	0.64	25	4T
1	25	$1^{1/4}$	32	0.0300	0.76	30	4T
$1^{1/4}$	32	$1^{5/8}$	41	0.0350	0.89	35	4T

^aThe weld thickness is the sum of the specified wall thickness and the estimated thickness of weld reinforcement.

Table 16—ASTM Hole-type IQI for Radiographic Inspection

(1)		(2)		(3)		(4)	(5)
Weld Thickness ^a				IQI Thickness		IQI Designation	Essential Hole
Over		Through		in.	mm		
in.	mm	in.	mm	in.	mm		
—	—	5/16	8	0.0100	0.25	10	2T
5/16	8	7/16	11	0.0125	0.32	12	2T
7/16	11	9/16	14	0.0150	0.38	15	2T
9/16	14	11/16	18	0.0175	0.44	17	2T
11/16	18	1	25	0.0200	0.51	20	2T
1	25	1 1/4	32	0.0250	0.64	25	2T
1 1/4	32	1 5/8	41	0.0300	0.76	30	2T

^aThe weld thickness is the sum of the specified wall thickness and the estimated thickness of weld reinforcement.

Table 17—ISO Wire-type IQI for Fluoroscopic Inspection

(1)		(2)		(3)		(4)		(5)		(6)	(7)
Weld Thickness ^a				Specified Wall Thickness				Essential Wire Diameter		Fe Wire Set	Wire Number
Over		Through		Over		Through		in.	mm		
in.	mm	in.	mm	in.	mm	in.	mm	in.	mm		
—	—	5/16	8	—	—	0.312	7.9	0.013	0.32	10/16 or 10/12	11
5/16	8	7/16	11	0.312	7.9	0.438	11.1	0.016	0.40	10/16 or 10/12	10
7/16	11	9/16	14	0.438	11.1	0.562	14.3	0.020	0.50	6/12	9
9/16	14	11/16	18	0.562	14.3	0.688	17.5	0.025	0.63	6/12	8
11/16	18	1	25	0.688	17.5	1.000	25.4	0.032	0.80	6/12 or 1/7	7
1	25	1 1/4	32	1	25.4	1.250	31.8	0.040	1.00	6/12 or 1/7	6
1 1/4	32	1 5/8	41	—	—	—	—	0.050	1.25	1/7	5

^aThe weld thickness is the sum of the specified wall thickness and the estimated thickness of weld reinforcement.

Notes:

1. The essential wire diameter based on weld thickness is used to verify proper sensitivity in locations with weld reinforcement.
2. The essential wire diameter based on specified wall thickness is used to verify proper sensitivity in locations without weld reinforcement.

Table 18—ISO Wire-type IQI for Radiographic Inspection

(1)		(2)		(3)		(4)		(5)		(6)	(7)
Weld Thickness ^a				Specified Wall Thickness				Essential Wire Diameter		Fe Wire Set	Wire Number
Over		Through		Over		Through		in.	mm		
in.	mm	in.	mm	in.	mm	in.	mm	in.	mm		
—	—	5/16	8	—	—	0.312	7.9	0.006	0.16	10/16	14
5/16	8	7/16	11	0.312	7.9	0.438	11.1	0.008	0.20	10/16	13
7/16	11	9/16	14	0.438	11.1	0.562	14.3	0.010	0.25	10/16 or 6/12	12
9/16	14	11/16	18	0.562	14.3	0.688	17.5	0.013	0.32	10/16 or 6/12	11
11/16	18	1	25	0.688	17.5	1.000	25.4	0.016	0.40	10/16 or 6/12	10
1	25	1 1/4	32	1	25.4	1.250	31.8	0.020	0.50	6/12	9
1 1/4	32	1 5/8	41	—	—	—	—	0.025	0.63	6/12	8

^aThe weld thickness is the sum of the specified wall thickness and the estimated thickness of weld reinforcement.

Notes:

1. The essential wire diameter based on weld thickness is used to verify proper sensitivity in locations with weld reinforcement.
2. The essential wire diameter based on specified wall thickness is used to verify proper sensitivity in locations without weld reinforcement.

Table 19—ASTM Wire-type IQI for Fluoroscopic Inspection

(1)		(2)		(3)		(4)		(5)		(6)	(7)
Weld Thickness ^a				Specified Wall Thickness				Essential Wire Diameter		Wire Set	Wire Identity
Over		Through		Over		Through					
in.	mm	in.	mm	in.	mm	in.	mm	in.	mm		
—	—	5/16	8	—	—	0.312	7.9	0.013	0.33	B	7
5/16	8	7/16	11	0.312	7.9	0.438	11.1	0.016	0.41	B	8
7/16	11	9/16	14	0.438	11.1	0.562	14.3	0.020	0.51	B	9
9/16	14	11/16	18	0.562	14.3	0.688	17.5	0.025	0.64	B	10
11/16	18	1	25	0.688	17.5	1.000	25.4	0.032	0.81	B or C	11
1	25	1 1/4	32	1	25.4	1.250	31.8	0.040	1.02	C	12
1 1/4	32	1 5/8	41	—	—	—	—	0.050	1.27	C	13

^aThe weld thickness is the sum of the specified wall thickness and the estimated thickness of weld reinforcement.

Notes:

1. The essential wire diameter based on weld thickness is used to verify proper sensitivity in locations with weld reinforcement.
2. The essential wire diameter based on specified wall thickness is used to verify proper sensitivity in locations without weld reinforcement.

Table 20—ASTM Wire-type IQI for Radiographic Inspection

(1)		(2)		(3)		(4)		(5)		(6)	(7)
Weld Thickness ^a				Specified Wall Thickness				Essential Wire Diameter		Wire Set	Wire Identity
Over		Through		Over		Through					
in.	mm	in.	mm	in.	mm	in.	mm	in.	mm		
—	—	5/16	8	—	—	0.312	7.9	0.0063	0.16	A	4
5/16	8	7/16	11	0.312	7.9	0.438	11.1	0.008	0.20	A	5
7/16	11	9/16	14	0.438	11.1	0.562	14.3	0.010	0.25	A or B	6
9/16	14	11/16	18	0.562	14.3	0.688	17.5	0.013	0.33	B	7
11/16	18	1	25	0.688	17.5	1.000	25.4	0.016	0.41	B	8
1	25	1 1/4	32	1	25.4	1.250	31.8	0.020	0.51	B	9
1 1/4	32	1 5/8	41	—	—	—	—	0.025	0.64	B	10

^aThe weld thickness is the sum of the specified wall thickness and the estimated thickness of weld reinforcement.

Notes:

1. The essential wire diameter based on weld thickness is used to verify proper sensitivity in locations with weld reinforcement.
2. The essential wire diameter based on specified wall thickness is used to verify proper sensitivity in locations without weld reinforcement.

Table 21—Elongated Slag-inclusion-type Discontinuities^a

(1)		(2)		(3)
Maximum Dimensions		Minimum Separation		Maximum Number in any 6 in. (152.4 mm)
in.	mm	in.	mm	
1/16 × 1/2	1.6 × 12.7	6	152.4	1
1/6 × 1/4	1.6 × 6.4	3	76.2	2
1/16 × 1/8	1.6 × 3.2	2	50.8	3

Note: See Figure 8.

^aMaximum accumulated length of discontinuities in any 6 in. (152.4 mm) shall not exceed 1/2 in. (12.7 mm).

Table 22—Circular Slag-inclusion-type and Gas-pocket-type Discontinuities^a

(1)		(2)		(3)		(4)
Size		Adjacent Size		Minimum Separation		Maximum Number in any 6 in. (152.4 mm)
in.	mm	in.	mm	in.	mm	
1/8 ^b	3.2	1/8 ^b	3.2	2	50.8	2
1/8 ^b	3.2	1/16	1.6	1	25.4	Varies
1/8 ^b	3.2	1/32	0.8	1/2	12.7	Varies
1/8 ^b	3.2	1/64	0.4	3/8	9.5	Varies
1/16	1.6	1/16	1.6	1/2	12.7	4
1/16	1.6	1/32	0.8	3/8	9.5	Varies
1/16	1.6	1/64	0.4	1/4	6.4	Varies
1/32	0.8	1/32	0.8	1/4 ^c	6.4	8
1/32	0.8	1/64	0.4	3/16	4.8	Varies
1/64	0.4	1/64	0.4	1/8	3.2	16

Note: See Figure 7.

^aThe sum of the diameters of all discontinuities in any 6 in. (152.4 mm) not to exceed 1/4 in. (6.4 mm).

^bMaximum size discontinuity for 0.250 in. (6.4 mm) wall and lighter shall be 3/32 in. (2.4 mm).

^cTwo discontinuities 1/32 in. (0.8 mm) or smaller may be as close as one diameter apart provided they are separated from any other discontinuity by at least 1/2 in. (12.7 mm).

Table 23—Acceptance Limits

(1)	(2)	(3)		(4)
		Hole Size		
Item	Notch Type	in.	mm	Acceptance Limit Signal, %
Submerged-arc, gas-metal arc, laser, and repair welds	N5	1/16	1.6	100
	N10	1/8	3.2	33 1/3
Electric welds	N10	1/8	3.2	100
Seamless Pipe	N12.5	1/8	3.2	100

Table 24—Pipe Weld Seam Nondestructive Inspection Methods

(1)	(2)	(3)	(4)
Nondestructive Inspection Methods			
Weld Seam Type	EMI	UT	RT
Electric	A	A	N
Laser	N	R	N
Submerged-arc	N	RU	NU
Gas Metal-arc	N	R	N
Skelp End	N	RU	NU

Legend:

- EMI = Electromagnetic inspection
- UT = Ultrasonic inspection
- RT = Radiographic inspection
- A = One method or a combination of methods are required
- N = Not required
- R = Required
- RU = Required, unless RT has been agreed upon between the purchaser and the manufacturer
- NU = Not required, unless RT has been agreed upon between the purchaser and the manufacturer

Notes:

1. This table is applicable to welded pipe in sizes of 2 3/8 and larger, in grades higher than Grade A 25.
2. The weld seam at the pipe ends may require additional inspection. (See 9.8.3.1.)

Table 25—Pipe Body Nondestructive Inspection Methods—Seamless

(1)	(2)	(3)	(4)
Nondestructive Inspection Methods			
Item	EMI	UT	MT
PSL 2	A	A	A
PSL 1 Grade B Q&T	A	A	A
PSL 1 Other	AI	AI	AI

Legend:

EMI = Electromagnetic inspection
 UT = Ultrasonic inspection
 MT = Magnetic particle inspection, circular field
 A = One method or a combination of methods are to be used
 AI = One method or a combination of methods are to be used if non-destructive inspection is specified on the purchase order.

Table 26—Reference Indicators

(1)	(2)	(3)	(4)	(5)	(6)	(7)	(8)	(9)			
Reference Indicators ^a											
Item	Notch Location		Notch Orientation		Depth ^b	Notch Dimensions, Maximum				Diameter of Radially Drilled Through-wall Hole ^d	
	OD	ID	Long.	Trans.		Length ^c		Width ^c		in.	r
Electric weld seam	R	R	R	N	10.0	2.0	50	0.040	1	1/8	3.2
Laser weld seam	R	R	R	N	5.0 ^e	2.0	50	0.040	1	1/16 ^e	1.6 ^e
Submerged-arc weld seam ^f	R	R	R	A	5.0 ^e	2.0	50	0.040	1	1/16 ^e	1.6 ^e
Gas metal-arc weld seam ^f	R	R	R	A	5.0 ^e	2.0	50	0.040	1	1/16 ^e	1.6 ^e
Skelp end weld seam ^f	R	R	R	A	5.0 ^e	2.0	50	0.040	1	1/16 ^e	1.6 ^e
Seamless (PSL 2)	R	R	R ^g	N	12.5	2.0	50	0.040	1	1/8	3.2
Seamless (PSL 1 Grade B Q&T)	RP	RP	R ^g	N	12.5	2.0	50	0.040	1	1/8	3.2
Seamless (PSL 1 Other)	RP	N	R ^g	N	12.5	2.0	50	0.040	1	1/8	3.2

^aReference indicators need not be located in the weld.^bDepth, expressed as a percentage of the specified wall thickness, with a minimum specified notch depth of 0.012 in. (0.3 mm). The depth tolerance shall be $\pm 15\%$ of the specified notch depth or ± 0.002 in. (0.05 mm), whichever is the greater. The notch types are designated N5, N10, and N12.5.^cAt full depth.^dDrilled hole diameters are based upon standard drill bit sizes. A hole is not required if a notch is used to establish the reject threshold.^eAt the option of the manufacturer, it shall be permissible for N10 notches or 1/8-in. (3.2-mm) radially drilled holes to be used.^fAt the option of the manufacturer, for submerged-arc weld seams and gas metal-arc weld seams it shall be permissible for the reject threshold to be established using weld-edge notches or weld-edge radially drilled holes.^gAt the option of the manufacturer, it shall be permissible for the notches to be oriented at such an angle as to optimize the detection of anticipated defects.

Legend:

R = Required if a notch is used to establish the reject threshold.

RP = Required for pipe of size 2³/₈ and larger, if a notch is used to establish the reject threshold.

N = Not required.

A = Either a transverse notch or a 1/16-in. (1.6-mm) radially drilled hole is required for inspection for transverse imperfections.

Notes:

1. For weld seam inspection, this table is applicable to welded pipe in sizes 2³/₈ and larger, in a grade higher than Grade A25.

2. Notches are rectangular or U-shaped, as shown in Figure 2 of ASTM E 213.

3. For electromagnetic inspection, it may be necessary for the reference standard to contain OD notches, ID notches and drilled holes. (See 9.8.5.2.)

Table 27—Retention of Records

Requirement	Reference
Chemical Properties	
Heat Analyses	Paragraph 9.2.1
Product Analyses	Paragraph 9.2.2
Mechanical Tests	
Tensile Tests	Paragraph 9.3.1
Weld Tensile Tests	Paragraph 9.3.1.5
Guided-bend Tests	Paragraph 9.3.4
Fracture Toughness Tests	Paragraph 9.3.5, SR5, SR6, SR19
Hydrostatic Tests	
Tester Recorder Charts (Where Used)	Paragraph 9.4.2
Supplementary Hydrostatic Tests	Paragraph 9.4.4
Visual Inspection	Paragraph 9.7
Nondestructive Inspection	
Qualification of Personnel	Paragraph 9.8.1
Radiographic Images (Where Used)	Paragraph 9.8.3.1
Welded Joints	
Radiographic Images	Paragraph A.4
Repair Welding Procedure	Paragraph C.1
Transverse Tensile Test	Paragraph C.2.2.2
Transverse Guided-bend Test	Paragraph C.2.2.3
Nick-break Test	Paragraph C.2.2.4

APPENDIX A—SPECIFICATION FOR WELDED JOINTERS (NORMATIVE)

A.1 Method

Welding of any type that uses deposited filler metal and is generally recognized as sound practice shall be permitted unless the purchaser specifies a particular method. Welding procedures, welders, and welding machine operators (hereafter called operators) shall be qualified in accordance with API Standard 1104. Copies of the welding procedure specification and procedure qualification record shall be provided to the purchaser upon request.

A.2 Workmanship

The ends of the pipe to be welded together shall be prepared in accordance with the requirements of the procedure to be used. Pipe weld seams (straight, helical, or skelp end) shall be staggered between 2 in. and 8 in. (51 mm and 203 mm) unless otherwise specified by the purchaser. The completed jointers shall be straight within the limits of 7.6 of this specification. Each weld shall have a substantially uniform cross section around the entire circumference of the pipe. At no

point shall its crowned surface be below the outside surface of the parent metal nor shall it rise above the parent metal by more than $\frac{1}{8}$ in. (3.18 mm) if submerged-arc welded, or by more than $\frac{1}{16}$ in. (1.59 mm), if welded by another process.

A.3 Marking

Each jointer shall be marked using paint to identify the welder or operator.

A.4 Nondestructive Testing

The girth welds of jointers shall be 100% radiographed in accordance with the procedures and standards of acceptability in API Standard 1104 (see note). Jointer welds failing to pass this radiographic testing may be repaired and re-radiographed in accordance with the procedures and acceptance criteria of API Standard 1104. Radiographic images shall be traceable to the pipe identity.

Note: See 7.7 for length requirements on jointers.

APPENDIX B—REPAIR OF DEFECTS BY WELDING (NORMATIVE)

B.1 Types Of Pipe

B.1.1 SEAMLESS PIPE AND PARENT METAL OF WELDED PIPE

For PSL 1 pipe, the repair of defects in seamless pipe and parent metal of welded pipe is permissible except (a) when the depth of the defect exceeds $33\frac{1}{3}\%$ of the specified wall thickness of the pipe and the length of that portion of the defect in which the depth exceeds $12\frac{1}{2}\%$ is greater than 25% of the specified outside diameter of the pipe; or (b) when more than one repair is required in any length equivalent to 10 times the specified outside diameter of the pipe. Repairs shall be made in accordance with B.2. Repair welds shall be inspected by the magnetic particle method in accordance with 9.7.5.1 through 9.7.5.3; by liquid penetrant; or by other NDT methods as agreed start between purchaser and the manufacturer.

For PSL 2, seamless pipe, the parent metal (body) of welded pipe, plate, and skelp shall not be repaired by welding.

B.1.2 WELD SEAM OF WELDED PIPE

B.1.2.1 Defects in filler metal welds may be repaired at the option of the manufacturer; such repairs shall be in accordance with B.3. All repair welds shall be inspected by ultrasonic methods in accordance with 9.8.5.1, 9.8.5.2, and 9.8.5.4., except that the equipment need not be capable of continuous and uninterrupted operation and, at the option of the manufacturer, repairs made by submerged-arc welding or by shielded metal-arc welding may alternatively be inspected by radiological methods in 9.8.4.

B.1.2.2 For PSL 1 pipe, weld seams made without filler metal (electric and laser welds) may be repaired by welding only by agreement between the purchaser and the manufacturer; such repairs shall be in accordance with B.4.

B.1.2.3 For PSL 2 pipe, weld seams made without filler metal shall not be repaired by welding.

B.1.3 HEAT TREATED PIPE

When heat treated pipe has been repaired by welding, the need for and type of reheat treatment shall be based on the effect of the repair on the structure and properties of the heat treated pipe, by agreement between the purchaser and the manufacturer.

B.2 Procedure for Repair by Welding of Seamless Pipe and Parent Metal of Welded Pipe (PSL 1 Only)

The repair of defects in seamless pipe and parent metal of welded pipe shall conform to the requirements listed in B.2.1-

B.2.5. Conformance to the repair procedure is subject to approval of the purchaser's inspector.

B.2.1 The defect shall be removed completely by chipping and/or grinding. The resulting cavity shall be thoroughly cleaned and shall be inspected before welding by magnetic particle methods in accordance with 9.8.6 to ensure complete removal of the defect.

B.2.2 The minimum length of repair weld shall be 2 in. (50.8 mm). Where the orientation of the defect permits, the repair weld shall be placed in the circumferential direction.

B.2.3 The repair weld shall be made either by automatic submerged-arc welding, gas metal-arc welding, or manual shielded metal-arc welding using low-hydrogen electrodes. The metal temperature in the area to be repaired shall be a minimum of 50°F (10°C). The welding procedure and performance shall be qualified in accordance with Appendix C.

B.2.4 The repair weld shall be ground to merge smoothly into the original contour of the pipe.

B.2.5 Repaired pipe shall be tested hydrostatically after repairing, in accordance with 9.4.

B.3 Procedure for Repair of Submerged-Arc and Gas Metal-Arc Welds

The repair of submerged-arc and gas metal-arc welds shall conform to the requirements listed in B.3.1-B.3.3. Conformance is subject to approval of purchaser's inspector.

B.3.1 The defect shall be completely removed and the cavity thoroughly cleaned. Where multiple pass repairs are used, the size of the cavity shall be sufficiently large [at least 2 in. (50.8 mm) in length] to avoid coincidence of starts and stops of individual passes.

B.3.2 The minimum length of each repair weld shall be 2 in. (50.8 mm). The repair weld shall be made either by automatic submerged-arc welding, gas metal-arc welding, or manual shielded metal-arc welding using low-hydrogen electrodes. The welding procedure and performance shall be qualified in accordance with Appendix C.

B.3.3 Each length of repaired pipe shall be tested hydrostatically in accordance with 9.4.

B.4 Procedure for Repair of Electric and Laser Welds (PSL 1 Only)

The repair of electric and laser welds shall conform to the requirements in B.4.1 through B.4.6 and shall include the weld zone, which is defined for the purposes of repair as $\frac{1}{2}$ in. (12.7 mm) on each side of the fusion line. Conformance to

the repair procedure is subject to approval of the purchaser's inspector.

B.4.1 The weld zone defect shall be removed completely by chipping and/or grinding, and the resulting cavity shall be thoroughly cleaned.

B.4.2 The minimum length of repair weld shall be 2 in. (50.8 mm), and individual weld repairs shall be separated by at least 10 ft (3 m).

B.4.3 The repair weld shall be made by either automatic submerged-arc welding, gas metal-arc welding, or manual shielded metal-arc welding using low-hydrogen electrodes. The metal temperature in the area to be repaired shall be a

minimum of 50°F (10°C). The welding procedure and performance shall be qualified in accordance with Appendix C.

B.4.4 When a repair weld is made through the full wall thickness, it shall include weld passes made from both the ID and the OD of the pipe. Starts and stops of the ID and OD repair welds shall not coincide.

B.4.5 The repair shall be ground to merge smoothly into the original contour of the pipe and shall have a maximum crown of 0.06 in. (1.52 mm).

B.4.6 Repaired pipe shall be hydrostatically tested after repair in accordance with 9.4.

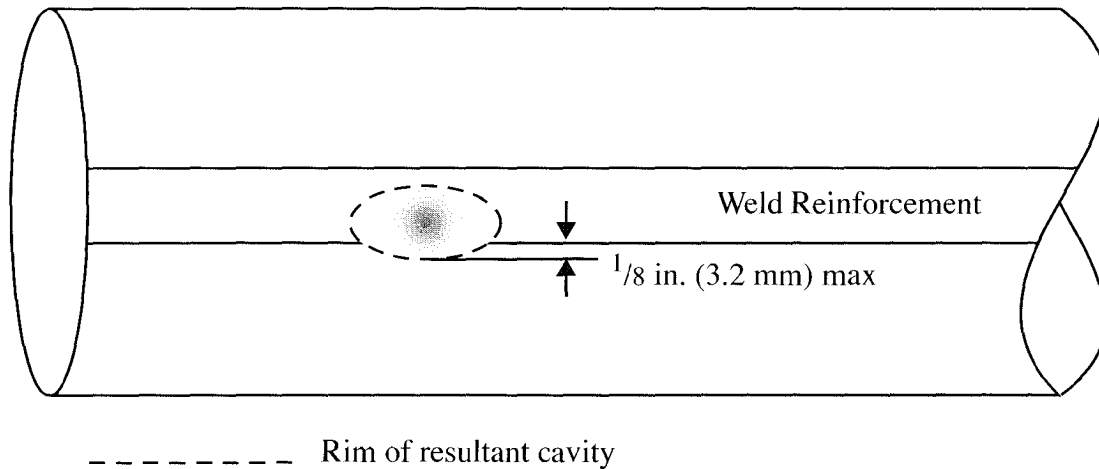

Figure B-1—Resultant Cavity for Undercut Repair (PSL 2 Only)

APPENDIX C—REPAIR WELDING PROCEDURE (NORMATIVE)

C.1 General

All repair welds shall be made in the flat position according to a qualified procedure and by a welding machine operator (hereafter called operator) or repair welder who is qualified in a flat position as specified in C.3. Repair welds may be made by one of the following methods:

- a. Automatic submerged arc.
- b. Automatic or semi-automatic gas metal arc.
- c. Manual shielded metal arc using low-hydrogen electrodes.

All welding materials shall be properly handled and stored in accordance with the manufacturer's recommendations so as to preclude moisture or other contamination. Test welds may be made on either plate stock or pipe stock at the option of the manufacturer.

The manufacturer shall maintain a record of the welding procedure and procedure qualification test results. Copies of the welding procedure specification and procedure qualification record shall be provided to the purchaser upon request.

C.2 Repair Welding Procedure Qualification

Welding procedures shall be qualified by preparing and testing welds in accordance with this appendix. At the option of the manufacturer, the tests specified in the ASME Boiler and Pressure Vessel Code, Section IX, may be substituted herein. For the purpose of this appendix, the term automatic welding includes both machine welding and automatic welding as defined in the ASME Boiler and Pressure Vessel Code, Section IX.

C.2.1 ESSENTIAL VARIABLES

An existing procedure shall not be applicable and new procedure shall be qualified when any of the following essential variables is changed beyond the stated limits:

- a. Welding process:
 1. A change in the welding process, such as submerged arc to gas metal arc.
 2. A change in the method, such as manual to semi-automatic.
- b. Pipe material:
 1. A change in grade category. When different alloying systems are used within one grade category, each alloying composition shall be separately qualified. Grade categories are as follows:
 - ≤ X42
 - > X42 and < X65
 - each grade ≥ X65

2. Within each grade category, a thicker material than the material qualified.

3. Within the grade category and thickness range, a carbon equivalent, CE (see note), based on product analysis for the material to be repaired, that is more than 0.04% greater than the CE of the material qualified.

Note:

$$CE = C + \frac{Mn}{6} + \frac{Cr + Mo + V}{5} + \frac{Ni + Cu}{15}$$

- c. Welding materials:
 1. A change in filler metal classification.
 2. A change in electrode diameter.
 3. A change of more than 5% in the composition of shielding gas.
 4. A change of more than 10% in the flow rate of shielding gas.
 5. A change in submerged-arc welding flux from one designation to another.
- d. Welding parameters:
 1. A change in the type of current (such as AC versus DC).
 2. A change in polarity.
 3. For automatic and semi-automatic welding, schedules of welding current, voltage, and speed may be established to cover ranges of wall thicknesses. Within the schedule, appropriately selected points shall be tested to qualify the entire schedule. Thereafter, a new qualification is required if there is a deviation from the qualified schedule greater than the following:
 - 10% in amperage
 - 7% in voltage
 - 10% in travel speed for automatic welding
- e. Weld bead: For manual and semi-automatic welding, a change in bead width greater than 50%.
- f. Preheat and post-weld heat treatment:
 1. Repair welding at a pipe temperature lower than the pipe temperature of the qualification test.
 2. The addition or deletion of post-weld heat treatment.

C.2.2 MECHANICAL TESTING

C.2.2.1 Number of Tests

Two specimens of each type are required from each procedure qualification test.

C.2.2.2 Transverse Tensile Test

The transverse tensile test specimens shall be approximately 1.5 in. (38.1 mm) wide and shall have the transverse

butt weld perpendicular to the longitudinal axis at the center of the test specimen (See Figure C-1 or Figure 4.) The weld reinforcement shall be removed from both faces. The ultimate tensile strength shall be at least equal to the minimum specified for the pipe grade.

C.2.2.3 Transverse Guided-Bend Test

The transverse guided-bend test specimens shall conform to Figure C-2. The weld shall be made in a groove as shown. Each specimen shall be placed on the die with the weld at mid-span and shall be bent approximately 180° in a jig in accordance with Figure C-3 and Table C-1, with the exposed surface of the weld in tension. The bend test shall be considered acceptable if no crack or other defect exceeding 1/8 in. (3.18 mm) in any direction is present in the weld metal or base metal after bending. Cracks that both originate along the edges of the specimen during testing and measure less than 1/4 in. (6.35 mm) in all directions shall not be considered.

C.2.2.4 Nick-Break Test

The nick-break specimens shall conform to Figure C-4. The weld shall be made in a groove as shown. Each specimen shall be saw-notched from both edges at the center of the weld and shall be broken by pulling or hammer blows at the center of one end. The exposed surface of the specimen shall be visually examined and shall be considered acceptable if it meets the following criteria:

- a. No gas pockets exceeding 1/16 in. (1.59 mm) in any direction.
- b. Not more than one gas pocket of any size for specified wall thicknesses of 0.250 in. (6.4 mm) and less.
- c. Not more than two gas pockets of any size for specified wall thicknesses of 0.500 in. (12.7 mm) or less but greater than 0.250 in. (6.4 mm).
- d. Not more than three gas pockets of any size for specified wall thicknesses greater than 0.500 in. (12.7 mm).
- e. Slag inclusions shall be separated by at least 1/2 in. (12.7 mm) of sound metal and shall appear no greater than 1/16 in. (1.59 mm) in width or 3/16 in. (4.76 mm) in length.

C.3 Welding Personnel Performance Qualification

C.3.1 QUALIFICATION

C.3.1.1 General

Each repair welder and operator is required to qualify. A repair welder or operator qualified on one grade category is qualified for any lower grade category provided the same welding process is used.

C.3.1.2 Testing

To qualify, a repair welder or operator shall produce welds that are acceptable in the following tests:

- a. Film radiographic examination per Section 9 of this specification.
- b. Two transverse guided-bend tests per C.2.2.3 of this appendix.
- c. Two nick-break tests per C.2.2.4 of this appendix.

C.3.1.3 Test Failures

If one or more of the tests in C.3.1.2 fail to meet the specified requirements, the welder or operator may make one additional qualification weld. If that weld fails one or more of the tests in C.3.1.2, the welder or operator is disqualified. No further retests shall be permitted until the welder has completed additional training.

C.3.2 REQUALIFICATION

Requalification in accordance with C.3.1 is required under the following circumstances:

- a. One year has elapsed since the last prior applicable qualification.
- b. The individual has not been welding using qualified procedures for a period of 3 months.
- c. There is reason to question the individual's ability.

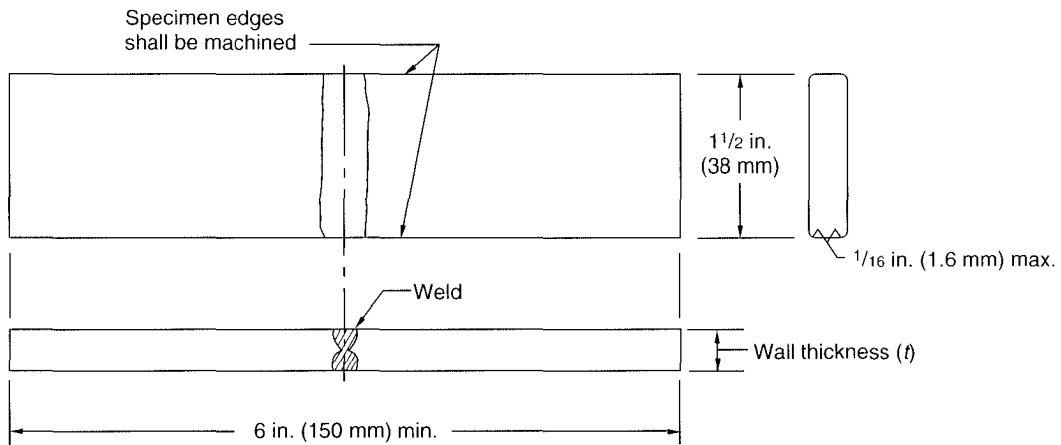

Note: Weld reinforcement shall be removed from both faces.

Figure C-1—Transverse Tensile Test Specimen

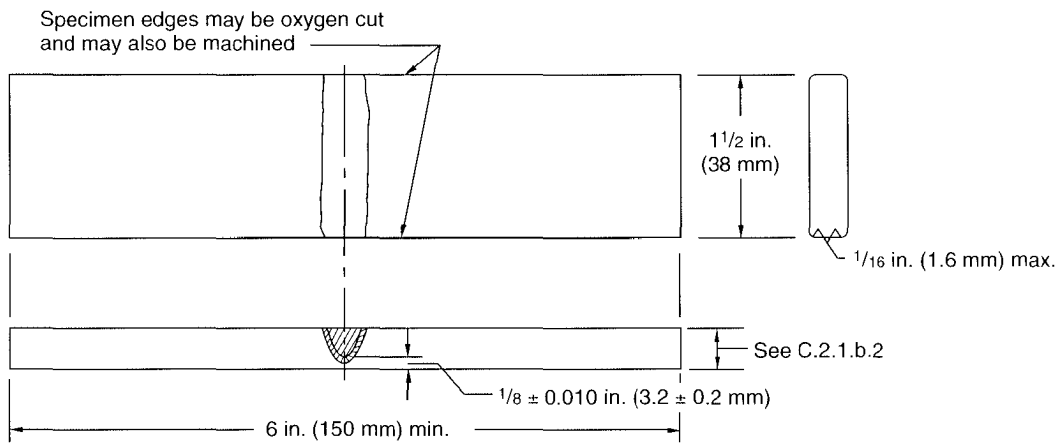

Note: Weld reinforcement shall be removed.

Figure C-2—Guided-bend Test Specimen

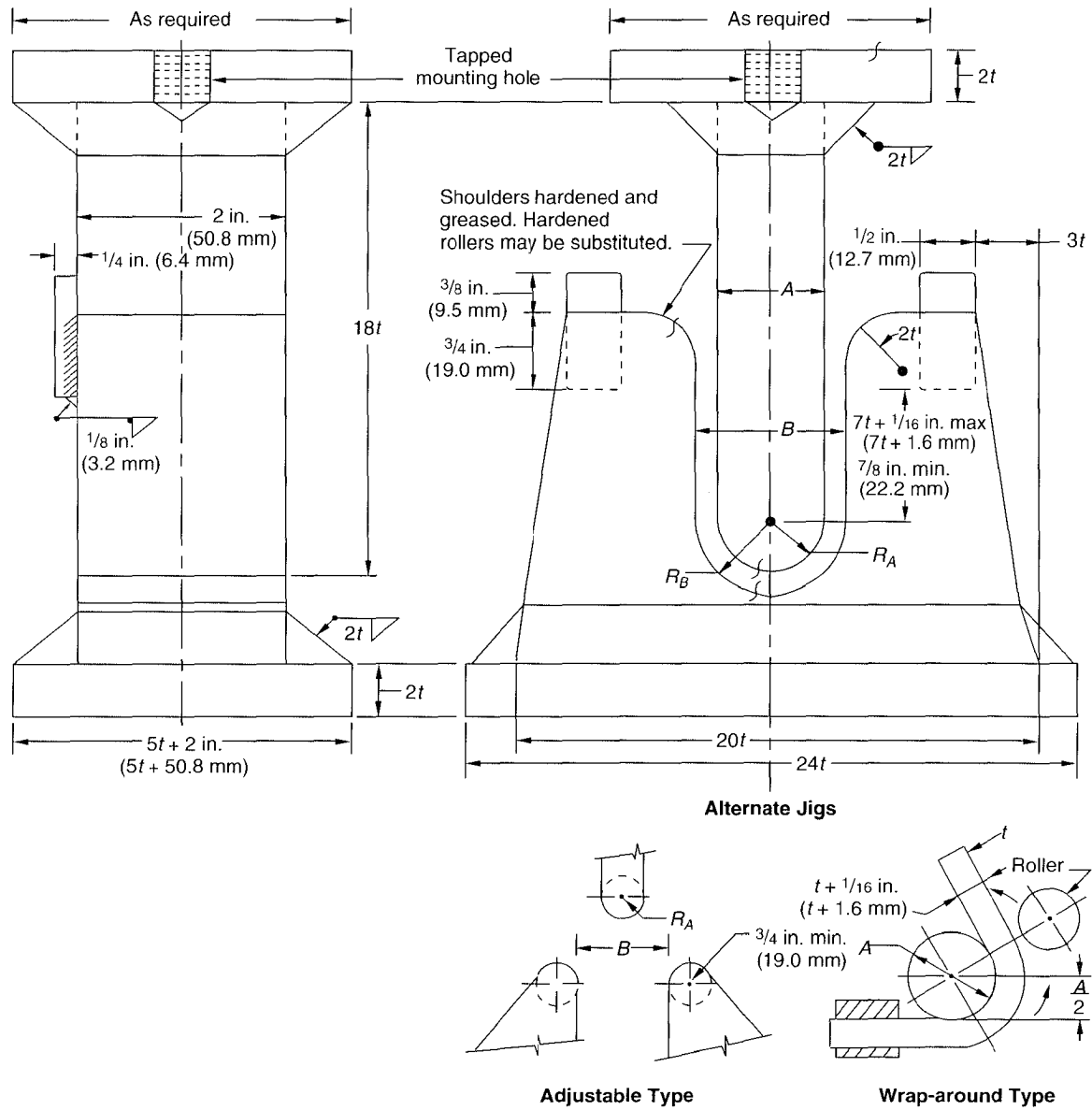

t = Specified wall thickness of pipe,

Note: See Table C-1.

Figure C-3—Jig for Guided-Bend Test

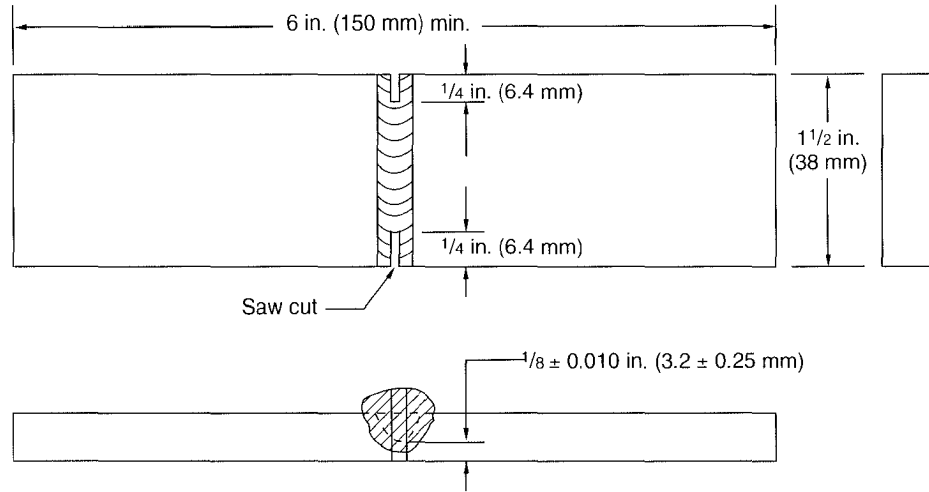

Figure C-4—Nick-Break Test Specimen

Table C-1—Guided-bend Test Jig Dimensions

(1)	(2)	(3)	(4)	(5)	(6)
	Pipe Grade ^a				
Member Dimension	A, B, & X42	X46	X52 & X56	X60 & X65	X70 & X80
Radius of male member, R_A	$3t$	$3\frac{1}{2}t$	$4t$	$4\frac{1}{2}t$	$5t$
Radius of female member, R_B	$4t + \frac{1}{16}$ in. $\frac{1}{2}t + \frac{1}{16}$ in.	$(4t + 1.6$ mm) $(4\frac{1}{2}t + 1.6$ mm)	$5t + \frac{1}{16}$ in. $(5t + 1.6$ mm)	$5\frac{1}{2}t + \frac{1}{16}$ in. $(5\frac{1}{2}t + 1.6$ mm)	$6t + \frac{1}{16}$ in. $(6t + 1.6$ mm)
Width of male member, A	$6t$	$7t$	$8t$	$9t$	$10t$
Width of groove in female member, B	$8t + \frac{1}{8}$ in. $(8t + 3.2$ mm)	$9t + \frac{1}{8}$ in. $(9t + 3.2$ mm)	$10t + \frac{1}{8}$ in. $(10t + 3.2$ mm)	$11t + \frac{1}{8}$ in. $(11t + 3.2$ mm)	$12t + \frac{1}{8}$ in. $(12t + 3.2$ mm)

Notes:

1. See Figure C-3.
2. t = specified wall thickness of the pipe.

^aFor intermediate grades of pipe, the dimensions of the bending jig shall conform to those shown for the next lower grade or shall be proportional thereto.

APPENDIX D—ELONGATION TABLE (NORMATIVE)

These minimum elongation values were calculated by the equation in Footnote a of Tables 3A and 3B.

Table D-1—Elongation Table (U.S. Customary Units)

(1)	(2)	(3)	(4)	(5)	(6)	(7)	(8)	(9)	(10)	(11)	(12)	(13)	(14)								
														Elongation in 2 in., Minimum (percent)							
														Specified Wall Thickness for Strip Specimen Testing (in.)			Grade				
														Strip Specimen Specified Width			A25	A	B & X42	X46	X52
Tensile Test Specimen Area (sq. in.)	Specified Minimum Ultimate Tensile Strength (psi)			45,000	48,000	60,000	63,000	66,000	71,000	75,000	77,000	82,000	90,000								
	³ / ₄ in.	1 in.	1 ¹ / ₂ in.																		
0.75	≥ 0.994	≥ 0.746	≥ 0.497	38	36	30	28	27	25	24	24	22	21								
0.74	.980 — .993	.735 — .745	.490 — .496	38	36	29	28	27	25	24	24	22	20								
0.73	.967 — .979	.726 — .734	.484 — .489	38	36	29	28	27	25	24	23	22	20								
0.72	.954 — .966	.715 — .725	.477 — .483	38	36	29	28	27	25	24	23	22	20								
0.71	.941 — .953	.706 — .714	.471 — .476	38	36	29	28	27	25	24	23	22	20								
0.70	.927 — .940	.695 — .705	.464 — .470	38	36	29	28	27	25	24	23	22	20								
0.69	.914 — .926	.686 — .694	.457 — .463	38	36	29	28	27	25	24	23	22	20								
0.68	.900 — .913	.675 — .685	.450 — .456	38	35	29	28	27	25	24	23	22	20								
0.67	.887 — .899	.666 — .674	.444 — .449	37	35	29	28	27	25	24	23	22	20								
0.66	.874 — .886	.655 — .665	.437 — .443	37	35	29	28	26	25	24	23	22	20								
0.65	.861 — .873	.646 — .654	.431 — .436	37	35	29	27	26	25	23	23	22	20								
0.64	.847 — .860	.635 — .645	.424 — .430	37	35	29	27	26	25	23	23	22	20								
0.63	.834 — .846	.626 — .634	.417 — .423	37	35	29	27	26	25	23	23	22	20								
0.62	.820 — .833	.615 — .625	.410 — .416	37	35	28	27	26	24	23	23	21	20								
0.61	.807 — .819	.606 — .614	.404 — .409	37	35	28	27	26	24	23	23	21	20								
0.60	.794 — .806	.595 — .605	.397 — .403	37	35	28	27	26	24	23	23	21	20								
0.59	.781 — .793	.586 — .594	.391 — .396	36	34	28	27	26	24	23	23	21	20								
0.58	.767 — .780	.575 — .585	.384 — .390	36	34	28	27	26	24	23	22	21	19								
0.57	.754 — .766	.566 — .574	.377 — .383	36	34	28	27	26	24	23	22	21	19								
0.56	.740 — .753	.555 — .565	.370 — .376	36	34	28	27	26	24	23	22	21	19								
0.55	.727 — .739	.546 — .554	.364 — .369	36	34	28	27	25	24	23	22	21	19								
0.54	.714 — .726	.535 — .545	.357 — .363	36	34	28	26	25	24	23	22	21	19								
0.53	.701 — .713	.526 — .534	.351 — .356	36	34	28	26	25	24	23	22	21	19								
0.52	.687 — .700	.515 — .525	.344 — .350	36	34	27	26	25	24	22	22	21	19								
0.51	.674 — .686	.506 — .514	.337 — .343	35	33	27	26	25	24	22	22	21	19								
0.50	.660 — .673	.495 — .505	.330 — .336	35	33	27	26	25	23	22	22	21	19								
0.49	.647 — .659	.486 — .494	.324 — .329	35	33	27	26	25	23	22	22	20	19								
0.48	.634 — .646	.475 — .485	.317 — .323	35	33	27	26	25	23	22	22	20	19								
0.47	.621 — .633	.466 — .474	.311 — .316	35	33	27	26	25	23	22	22	20	19								
0.46	.607 — .620	.455 — .465	.304 — .310	35	33	27	26	25	23	22	21	20	19								
0.45	.594 — .606	.446 — .454	.297 — .303	35	33	27	26	24	23	22	21	20	19								
0.44	.580 — .593	.435 — .445	.290 — .296	34	32	27	25	24	23	22	21	20	18								
0.43	.567 — .579	.426 — .434	.284 — .289	34	32	26	25	24	23	22	21	20	18								
0.42	.554 — .566	.415 — .425	.277 — .283	34	32	26	25	24	23	22	21	20	18								
0.41	.541 — .553	.406 — .414	.271 — .276	34	32	26	25	24	23	21	21	20	18								
0.40	.527 — .540	.395 — .405	.264 — .270	34	32	26	25	24	22	21	21	20	18								
0.39	.514 — .526	.386 — .394	.257 — .263	34	32	26	25	24	22	21	21	20	18								
0.38	.500 — .513	.375 — .385	.250 — .256	33	32	26	25	24	22	21	21	19	18								
0.37	.487 — .499	.366 — .374	.244 — .249	33	31	26	25	24	22	21	20	19	18								
0.36	.474 — .486	.355 — .365	.237 — .243	33	31	26	24	23	22	21	20	19	18								
0.35	.461 — .473	.346 — .354	.231 — .236	33	31	25	24	23	22	21	20	19	18								
0.34	.447 — .460	.335 — .345	.224 — .230	33	31	25	24	23	22	21	20	19	18								
0.33	.434 — .446	.326 — .334	.217 — .223	32	31	25	24	23	22	21	20	19	17								
0.32	.420 — .433	.315 — .325	.210 — .216	32	30	25	24	23	21	20	20	19	17								
0.31	.407 — .419	.306 — .314	.204 — .209	32	30	25	24	23	21	20	20	19	17								
0.30	.394 — .406	.295 — .305	.197 — .203	32	30	25	24	23	21	20	20	19	17								
0.29	.381 — .393	.286 — .294	.191 — .196	32	30	24	23	22	21	20	20	18	17								
0.28	.367 — .380	.275 — .285	.184 — .190	31	30	24	23	22	21	20	19	18	17								
0.27	.354 — .366	.266 — .274	.177 — .183	31	29	24	23	22	21	20	19	18	17								
0.26	.340 — .353	.255 — .265	.170 — .176	31	29	24	23	22	21	20	19	18	17								
0.25	.327 — .339	.246 — .254	.164 — .169	31	29	24	23	22	20	19	19	18	16								

04

Table D-1—Elongation Table (U.S. Customary Units) (Continued)

(1)	(2)	(3)	(4)	(5)	(6)	(7)	(8)	(9)	(10)	(11)	(12)	(13)	(14)
Elongation in 50.8 mm, Minimum (percent)													
Tensile Test Specimen Area (mm ²)	Specified Wall Thickness for Strip Specimen Testing (mm)			Grade									
	Strip Specimen Specified Width			A25	A	B & X42	X46	X52	X56	X60	X65	X70	X80
				Specified Minimum Ultimate Tensile Strength (MPa)									
	19.0 mm	25.4 mm	38.1 mm	310	331	414	434	455	490	517	531	565	621
0.24	.314 — .326	.235 — .245	.157 — .163	30	29	24	23	22	20	19	19	18	16
0.23	.301 — .313	.226 — .234	.151 — .156	30	29	23	22	21	20	19	19	18	16
0.22	.287 — .300	.215 — .225	.144 — .150	30	28	23	22	21	20	19	18	17	16
0.21	.274 — .286	.206 — .214	.137 — .143	30	28	23	22	21	20	19	18	17	16
0.20	.260 — .273	.195 — .205	.130 — .136	29	28	23	22	21	19	19	18	17	16
0.19	.247 — .259	.186 — .194	.124 — .129	29	27	22	21	21	19	18	18	17	16
0.18	.234 — .246	.175 — .185	.117 — .123	29	27	22	21	20	19	18	18	17	15
0.17	.221 — .233	.166 — .174	.111 — .116	28	27	22	21	20	19	18	18	17	15
0.16	.207 — .220	.155 — .165	.104 — .110	28	27	22	21	20	19	18	17	16	15
0.15	.194 — .206	.146 — .154	.097 — .103	28	26	21	20	20	18	18	17	16	15
0.14	.180 — .193	.135 — .145	.090 — .096	27	26	21	20	19	18	17	17	16	15
0.13	.167 — .179	.126 — .134	.084 — .089	27	25	21	20	19	18	17	17	16	14
0.12	.154 — .166	.115 — .125	.083	27	25	20	20	19	18	17	16	15	14
0.11	.141 — .153	.106 — .114	—	26	25	20	19	18	17	16	16	15	14
0.10	.127 — .140	.095 — .105	—	26	24	20	19	18	17	16	16	15	14
0.09	.114 — .126	.086 — .094	—	25	24	19	19	18	17	16	15	15	13
0.08	.100 — .113	.083 — .085	—	24	23	19	18	17	16	15	15	14	13
0.07	.087 — .099	—	—	24	22	18	18	17	16	15	15	14	13
0.06	.083 — .086	—	—	23	22	18	17	16	15	15	14	13	12

Table D-2—Elongation Table (SI Units)

(1)	(2)	(3)	(4)	(5)	(6)	(7)	(8)	(9)	(10)	(11)	(12)	(13)	(14)
Elongation in 50.8 mm, Minimum (%)													
Tensile Test Specimen Area (mm ²)	Specified Wall Thickness for Strip Specimen Testing (in.)			Grade									
				A25	A	B & X42	X46	X52	X56	X60	X65	X70	X80
	Strip Specimen Specified Width			Specified Minimum Ultimate Tensile Strength (MPa)									
19.0 mm	25.4 mm	38.1 mm	310	331	414	434	455	490	517	531	565	621	
485	—	≥ 19.1	≥ 12.7	38	36	30	28	27	25	24	24	22	21
480	—	18.7 – 19.0	12.5 – 12.6	38	36	29	28	27	25	24	24	22	20
470	—	18.3 – 18.6	12.2 – 12.4	38	36	29	28	27	25	24	23	22	20
460	—	17.9 – 18.2	11.9 – 12.1	38	36	29	28	27	25	24	23	22	20
450	—	17.5 – 17.8	11.7 – 11.8	38	36	29	28	27	25	24	23	22	20
440	—	17.1 – 17.4	11.4 – 11.6	38	35	29	28	27	25	24	23	22	20
430	—	16.7 – 17.0	11.2 – 11.3	37	35	29	28	26	25	24	23	22	20
420	—	16.3 – 16.6	10.9 – 11.1	37	35	29	28	26	25	24	23	22	20
410	—	15.9 – 16.2	10.6 – 10.8	37	35	29	27	26	25	23	23	22	20
400	—	15.6 – 15.8	10.4 – 10.5	37	35	28	27	26	24	23	23	21	20
390	—	15.2 – 15.5	10.1 – 10.3	37	35	28	27	26	24	23	23	21	20
380	—	14.8 – 15.1	9.8 – 10.0	37	34	28	27	26	24	23	22	21	20
370	—	14.4 – 14.7	9.6 – 9.7	36	34	28	27	26	24	23	22	21	19
360	—	14.0 – 14.3	9.3 – 9.5	36	34	28	27	26	24	23	22	21	19
350	—	13.6 – 13.9	9.1 – 9.2	36	34	28	27	25	24	23	22	21	19
340	—	13.2 – 13.5	8.8 – 9.0	36	34	28	26	25	24	23	22	21	19
330	—	12.8 – 13.1	8.5 – 8.7	35	33	27	26	25	24	22	22	21	19
320	—	12.4 – 12.7	8.3 – 8.4	35	33	27	26	25	23	22	22	21	19
310	—	12.0 – 12.3	8.0 – 8.2	35	33	27	26	25	23	22	22	20	19
300	—	11.6 – 11.9	7.7 – 7.9	35	33	27	26	25	23	22	21	20	19
290	15.0 – 15.2	11.2 – 11.5	7.5 – 7.6	35	33	27	26	24	23	22	21	20	19
280	14.5 – 14.9	10.8 – 11.1	7.2 – 7.4	34	32	26	25	24	23	22	21	20	18
270	13.9 – 14.4	10.4 – 10.7	7.0 – 7.1	34	32	26	25	24	23	22	21	20	18
260	13.4 – 13.8	10.0 – 10.3	6.7 – 6.9	34	32	26	25	24	22	21	21	20	18
250	12.9 – 13.3	9.6 – 9.9	6.4 – 6.6	34	32	26	25	24	22	21	21	20	18
240	12.4 – 12.8	9.3 – 9.5	6.2 – 6.3	33	31	26	25	24	22	21	21	19	18
230	11.8 – 12.3	8.9 – 9.2	5.9 – 6.1	33	31	25	24	23	22	21	20	19	18
220	11.3 – 11.7	8.5 – 8.8	5.6 – 5.8	33	31	25	24	23	22	21	20	19	18
210	10.8 – 11.2	8.1 – 8.4	5.4 – 5.5	32	31	25	24	23	21	20	20	19	17
200	10.3 – 10.7	7.7 – 8.0	5.1 – 5.3	32	30	25	24	23	21	20	20	19	17
190	9.7 – 10.2	7.3 – 7.6	4.9 – 5.0	32	30	24	23	23	21	20	20	19	17
180	9.2 – 9.6	6.9 – 7.2	4.6 – 4.8	31	30	24	23	22	21	20	19	18	17
170	8.7 – 9.1	6.5 – 6.8	4.3 – 4.5	31	29	24	23	22	21	20	19	18	17
160	8.2 – 8.6	6.1 – 6.4	4.1 – 4.2	31	29	24	23	22	20	19	19	18	16
150	7.6 – 8.1	5.7 – 6.0	3.8 – 4.0	30	29	23	22	21	20	19	19	18	16
140	7.1 – 7.5	5.3 – 5.6	3.5 – 3.7	30	28	23	22	21	20	19	18	17	16
130	6.6 – 7.0	4.9 – 5.2	3.3 – 3.4	29	28	23	22	21	20	19	18	17	16
120	6.1 – 6.5	4.5 – 4.8	3.0 – 3.2	29	27	22	21	21	19	18	18	17	16
110	5.5 – 6.0	4.1 – 4.4	2.8 – 2.9	28	27	22	21	20	19	18	18	17	15
100	5.0 – 5.4	3.7 – 4.0	2.5 – 2.7	28	26	22	21	20	19	18	17	16	15
90	4.5 – 4.9	3.3 – 3.6	2.2 – 2.4	27	26	21	20	19	18	17	17	16	15
80	3.9 – 4.4	3.0 – 3.2	2.1	27	25	21	20	19	18	17	16	16	14
70	3.4 – 3.8	2.6 – 2.9	—	26	25	20	19	18	17	16	16	15	14
60	2.9 – 3.3	2.2 – 2.5	—	25	24	19	19	18	17	16	16	15	14
50	2.4 – 2.8	2.1	—	24	23	19	18	17	16	15	15	14	13
40	2.1 – 2.3	—	—	23	22	18	17	16	15	15	14	14	12

04

04

APPENDIX E—DIMENSIONS, WEIGHTS, AND TEST PRESSURES—SI UNITS (NORMATIVE)

Tables E-6A, E-6B, and E-6C provide the SI unit values for dimensions, weights per unit length, and test pressures, corre-

sponding to the U.S. Customary unit values given in Tables 6A, 6B, and 6C.

Table E-6A—Plain-end Line Pipe Dimensions, Weights per Unit Length, and Test Pressures for Sizes 0.405 Through 1.900 (SI Units)

(1) Size	(2) Specified Outside Diameter <i>D</i> (mm)	(3) Specified Wall Thickness <i>t</i> (mm)	(4) Plain-end Weight per Unit Length <i>w_{pe}</i> (kg/m)	(5) Calculated Inside Diameter ^a <i>d</i> (mm)	(6) Grade A25	(7)–(10) Minimum Test Pressure ^b (kPa × 100) ^c			
						Grade A		Grade B	
						Std.	Alt.	Std.	Alt.
0.405	10.3	1.7	0.36	6.9	48	48	—	48	—
0.405	10.3	2.4	0.47	5.5	59	59	—	59	—
0.540	13.7	2.2	0.62	9.3	48	48	—	48	—
0.540	13.7	3.0	0.79	7.7	59	59	—	59	—
0.675	17.1	2.3	0.84	12.5	48	48	—	48	—
0.675	17.1	3.2	1.10	10.7	59	59	—	59	—
0.840	21.3	2.8	1.28	15.7	48	48	—	48	—
0.840	21.3	3.7	1.61	13.9	59	59	—	59	—
0.840	21.3	7.5	2.55	6.3	69	69	—	69	—
1.050	26.7	2.9	1.70	20.9	48	48	—	48	—
1.050	26.7	3.9	2.19	18.9	59	59	—	59	—
1.050	26.7	7.8	3.64	11.1	69	69	—	69	—
1.315	33.4	3.4	2.52	26.6	48	48	—	48	—
1.315	33.4	4.5	3.21	24.4	59	59	—	59	—
1.315	33.4	9.1	5.45	15.2	69	69	—	69	—
1.660	42.2	3.6	3.43	35.0	69	83	—	90	—
1.660	42.2	4.9	4.51	32.4	90	124	—	131	—
1.660	42.2	9.7	7.77	22.8	96	152	—	158	—
1.900	48.3	3.7	4.07	40.9	69	83	—	90	—
1.900	48.3	5.1	5.43	38.1	90	124	—	131	—
1.900	48.3	10.2	9.58	27.9	96	152	—	158	—

Note: See Table 6A for U.S. Customary unit values corresponding to the SI unit values given in this table.

^aThe calculated inside diameters are given here for information (see 7.2).

^bThe test pressures given in E-6A, E-6B, and E-6C apply to Grades A25, A, B, X42, X46, X52, X56, X60, X65, X70, and X80 only. See 9.4.3 for pressures applicable to other grades.

^c100 kPa = 1 bar.

Table E-6B—Plain-end Line Pipe Dimensions, Weights per Unit Length, and Test Pressures for Sizes $2\frac{3}{8}$ through $5\frac{9}{16}$ (SI Units)

(1) Size	(2) Specified Outside Diameter <i>D</i> (mm)	(3) Specified Wall Thickness <i>t</i> (mm)	(4) Plain-end Weight per Unit Length <i>w_{pe}</i> (kg/m)	(5) Calculated Inside Diameter ^d <i>d</i> (mm)	(6)–(16) Minimum Test Pressure ^b (kPa × 100) ^c												
					Grade												
					A25	A	B	X42	X46	X52	X56	X60	X65	X70	X80		
$2\frac{3}{8}$ ^d	60.3	2.1	3.01	56.1	Std.	41	87	101	121	132	150	161	173	187	202	207	
					Alt.	—	108	126	151	166	188	202	216	234	252	288	
$2\frac{3}{8}$ ^d	60.3	2.8	3.97	54.7	Std.	55	115	134	162	177	200	207	207	207	207	207	207
					Alt.	—	144	168	202	221	250	269	288	312	336	384	
$2\frac{3}{8}$ ^d	60.3	3.2	4.51	53.9	Std.	69	132	153	185	202	207	207	207	207	207	207	207
					Alt.	—	165	172	231	252	286	307	330	357	384	439	
$2\frac{3}{8}$ ^d	60.3	3.6	5.03	53.1	Std.	69	148	172	207	207	207	207	207	207	207	207	207
					Alt.	—	172	172	260	284	321	346	371	401	433	494	
$2\frac{3}{8}$	60.3	3.9	5.42	52.5	Std.	69	161	172	207	207	207	207	207	207	207	207	207
					Alt.	—	172	172	281	308	348	374	402	435	469	500	
$2\frac{3}{8}$	60.3	4.4	6.07	51.5	Std.	76	172	172	207	207	207	207	207	207	207	207	207
					Alt.	—	172	172	317	347	393	422	453	490	500	500	
$2\frac{3}{8}$	60.3	4.8	6.57	50.7	Std.	83	172	172	207	207	207	207	207	207	207	207	207
					Alt.	—	172	172	346	379	429	461	494	500	500	500	
$2\frac{3}{8}$	60.3	5.5	7.43	49.3	Std.	90	172	172	207	207	207	207	207	207	207	207	207
					Alt.	—	172	172	397	434	491	500	500	500	500	500	
$2\frac{3}{8}$	60.3	6.4	8.51	47.5	Std.	96	172	172	207	207	207	207	207	207	207	207	207
					Alt.	—	172	172	462	500	500	500	500	500	500	500	
$2\frac{3}{8}$	60.3	7.1	9.31	46.1	Std.	96	172	172	207	207	207	207	207	207	207	207	207
					Alt.	—	172	172	500	500	500	500	500	500	500	500	
$2\frac{3}{8}$	60.3	11.1	13.47	38.1	Std.	96	172	172	207	207	207	207	207	207	207	207	207
					Alt.	—	172	172	500	500	500	500	500	500	500	500	
$2\frac{7}{8}$ ^d	73.0	2.1	3.67	68.8	Std.	41	71	83	100	109	124	133	143	155	167	191	
					Alt.	—	89	104	125	137	155	167	179	193	208	238	
$2\frac{7}{8}$ ^d	73.0	2.8	4.85	67.4	Std.	55	95	111	133	146	165	178	191	206	207	207	
					Alt.	—	119	139	167	182	207	222	238	258	278	318	
$2\frac{7}{8}$ ^d	73.0	3.2	5.51	66.6	Std.	69	109	127	153	167	189	203	207	207	207	207	
					Alt.	—	136	158	191	208	236	254	272	295	318	363	
$2\frac{7}{8}$ ^d	73.0	3.6	6.16	65.8	Std.	69	122	143	172	188	207	207	207	207	207	207	
					Alt.	—	153	172	215	234	266	286	306	331	357	408	
$2\frac{7}{8}$	73.0	4.0	6.81	65.0	Std.	69	136	158	191	207	207	207	207	207	207	207	
					Alt.	—	170	172	238	261	295	317	340	368	397	454	
$2\frac{7}{8}$	73.0	4.4	7.44	64.2	Std.	69	150	172	207	207	207	207	207	207	207	207	
					Alt.	—	172	172	262	287	325	349	374	405	437	499	
$2\frac{7}{8}$	73.0	4.8	8.07	63.4	Std.	69	163	172	207	207	207	207	207	207	207	207	
					Alt.	—	172	172	286	313	354	381	408	442	476	500	
$2\frac{7}{8}$	73.0	5.2	8.69	62.6	Std.	69	172	172	207	207	207	207	207	207	207	207	
					Alt.	—	172	172	310	339	384	412	442	479	500	500	
$2\frac{7}{8}$	73.0	5.5	9.16	62.0	Std.	76	172	172	207	207	207	207	207	207	207	207	
					Alt.	—	172	172	328	358	406	436	468	500	500	500	
$2\frac{7}{8}$	73.0	6.4	10.51	60.2	Std.	83	172	172	207	207	207	207	207	207	207	207	
					Alt.	—	172	172	381	417	472	500	500	500	500	500	
$2\frac{7}{8}$	73.0	7.0	11.39	59.0	Std.	90	172	172	207	207	207	207	207	207	207	207	
					Alt.	—	172	172	417	456	500	500	500	500	500	500	
$2\frac{7}{8}$	73.0	14.0	20.37	45.0	Std.	96	172	172	207	207	207	207	207	207	207	207	
					Alt.	—	172	172	500	500	500	500	500	500	500	500	
$3\frac{1}{2}$ ^d	88.9	2.1	4.50	84.7	Std.	41	59	68	82	90	102	109	117	127	137	156	
					Alt.	—	73	85	103	112	127	137	147	159	171	196	
$3\frac{1}{2}$ ^d	88.9	2.8	5.95	83.3	Std.	55	78	91	110	120	136	146	156	169	183	207	
					Alt.	—	98	114	137	150	170	182	196	212	228	261	

Table E-6B—Plain-end Line Pipe Dimensions, Weights per Unit Length, and Test Pressures for Sizes 2³/₈ through 5⁹/₁₆ (SI Units) (Continued)

(1)	(2)	(3)	(4)	(5)	(6)	(7)	(8)	(9)	(10)	(11)	(12)	(13)	(14)	(15)	(16)	
Size	Specified Outside Diameter <i>D</i> (mm)	Specified Wall Thickness <i>t</i> (mm)	Plain-end Weight per Unit Length <i>w_{pe}</i> (kg/m)	Calculated Inside Diameter ^a <i>d</i> (mm)	Minimum Test Pressure ^b (kPa × 100) ^c											
					Grade A25	Grade A	Grade B	Grade X42	Grade X46	Grade X52	Grade X56	Grade X60	Grade X65	Grade X70	Grade X80	
3 ¹ / ₂ ^d	88.9	3.2	6.76	82.5	Std.	69	89	104	125	137	155	167	179	194	207	207
					Alt.	—	112	130	157	171	194	208	224	242	261	298
3 ¹ / ₂ ^d	88.9	3.6	7.57	81.7	Std.	69	101	117	141	154	174	188	201	207	207	207
					Alt.	—	126	146	176	193	218	234	251	272	293	335
3 ¹ / ₂ ^d	88.9	4.0	8.37	80.9	Std.	69	112	130	157	171	194	207	207	207	207	207
					Alt.	—	140	163	196	214	242	261	279	302	326	373
3 ¹ / ₂	88.9	4.4	9.17	80.1	Std.	69	123	143	172	188	207	207	207	207	207	207
					Alt.	—	154	172	215	235	267	287	307	333	359	410
3 ¹ / ₂	88.9	4.8	9.95	79.3	Std.	69	134	156	188	205	207	207	207	207	207	207
					Alt.	—	168	172	235	257	291	313	335	363	391	447
3 ¹ / ₂	88.9	5.5	11.31	77.9	Std.	69	154	172	207	207	207	207	207	207	207	207
					Alt.	—	172	172	269	294	333	358	384	416	448	500
3 ¹ / ₂	88.9	6.4	13.02	76.1	Std.	—	172	172	207	207	207	207	207	207	207	207
					Alt.	—	172	172	313	342	388	417	447	484	500	500
3 ¹ / ₂	88.9	7.1	14.32	74.7	Std.	—	172	172	207	207	207	207	207	207	207	207
					Alt.	—	172	172	347	380	430	462	496	500	500	500
3 ¹ / ₂	88.9	7.6	15.24	73.7	Std.	90	172	172	207	207	207	207	207	207	207	207
					Alt.	—	172	172	372	407	460	495	500	500	500	500
3 ¹ / ₂	88.9	15.2	27.63	58.5	Std.	—	172	172	207	207	207	207	207	207	207	207
					Alt.	—	172	172	500	500	500	500	500	500	500	500
4 ^d	101.6	2.1	5.15	97.4	Std.	—	51	60	72	79	89	96	103	111	120	137
					Alt.	—	64	75	90	98	111	120	128	139	150	171
4 ^d	101.6	2.8	6.82	96.0	Std.	41	68	80	96	105	119	128	137	148	160	183
					Alt.	—	86	100	120	131	148	160	171	185	200	228
4 ^d	101.6	3.2	7.76	95.2	Std.	—	78	91	110	120	136	146	156	169	183	207
					Alt.	—	98	114	137	150	170	182	196	212	228	261
4 ^d	101.6	3.6	8.70	94.4	Std.	55	88	102	123	135	153	164	176	190	205	207
					Alt.	—	110	128	154	168	191	205	220	238	257	293
4 ^d	101.6	4.0	9.63	93.6	Std.	—	98	114	137	150	170	182	196	207	207	207
					Alt.	—	122	142	171	187	212	228	244	265	285	326
4	101.6	4.4	10.55	92.8	Std.	69	108	125	151	165	187	201	207	207	207	207
					Alt.	—	134	157	188	206	233	251	269	291	314	359
4	101.6	4.8	11.46	92.0	Std.	83	117	137	164	180	204	207	207	207	207	207
					Alt.	—	147	171	206	225	254	274	293	317	342	391
4	101.6	5.7	13.48	90.2	Std.	83	139	162	195	207	207	207	207	207	207	207
					Alt.	—	174	193	244	267	302	325	348	377	406	465
4	101.6	6.4	15.02	88.8	Std.	—	156	182	207	207	207	207	207	207	207	207
					Alt.	—	193	193	274	300	339	365	391	423	456	500
4	101.6	7.1	16.55	87.4	Std.	—	174	193	207	207	207	207	207	207	207	207
					Alt.	—	193	193	304	332	376	405	434	470	500	500
4	101.6	8.1	18.68	85.4	Std.	117	193	193	207	207	207	207	207	207	207	207
					Alt.	—	193	193	347	379	429	462	495	500	500	500
4 ¹ / ₂ ^d	114.3	2.1	5.81	110.1	Std.	—	46	53	64	70	79	85	91	99	106	122
					Alt.	—	57	66	80	87	99	106	114	123	133	152
4 ¹ / ₂ ^d	114.3	3.2	8.77	107.9	Std.	55	70	81	97	106	121	130	139	151	162	185
					Alt.	—	87	101	122	133	151	162	174	188	203	232
4 ¹ / ₂ ^d	114.3	3.6	9.83	107.1	Std.	—	78	91	110	120	136	146	156	169	183	207
					Alt.	—	98	114	137	150	170	182	196	212	228	261
4 ¹ / ₂ ^d	114.3	4.0	10.88	106.3	Std.	69	87	101	122	133	151	162	174	188	203	207
					Alt.	—	109	127	152	166	188	203	217	235	254	290

Table E-6B—Plain-end Line Pipe Dimensions, Weights per Unit Length, and Test Pressures for Sizes 2³/₈ through 5⁹/₁₆ (SI Units) (Continued)

(1)	(2)	(3)	(4)	(5)	(6)	(7)	(8)	(9)	(10)	(11)	(12)	(13)	(14)	(15)	(16)
Size	Specified Outside Diameter <i>D</i> (mm)	Specified Wall Thickness <i>t</i> (mm)	Plain-end Weight per Unit Length <i>w_{pe}</i> (kg/m)	Calculated Inside Diameter ^a <i>d</i> (mm)	Minimum Test Pressure ^b (kPa × 100) ^c										
					Grade A25	Grade A	Grade B	Grade X42	Grade X46	Grade X52	Grade X56	Grade X60	Grade X65	Grade X70	Grade X80
5 ⁹ / ₁₆	141.3	19.1	57.56	103.1	Std.	193	193	193	207	207	207	207	207	207	207
					Alt.	—	193	193	500	500	500	500	500	500	500

Note: See Table 6B for U.S. Customary unit values corresponding to the SI unit values given in this table.

^aThe calculated inside diameters are given here for information (see 7.2).

^bThe test pressures given in Tables E-6A, E-6B, and E-6C apply to Grades A25, A, B, X42, X46, X52, X56, X60, X65, X70, and X80 only. See 9.4.3 for pressures applicable to other grades.

^c100 kPa = 1 bar.

^dPipe that has this combination of specified outside diameter and specified wall thickness is special plain-end pipe; other combinations given in this table are regular plain-end pipe. Pipe that has a combination of specified outside diameter and specified wall thickness that is intermediate to the tabulated values is considered to be special plain-end pipe if the next lower tabulated value is for special plain-end pipe; other intermediate combinations are considered to be regular plain-end pipe. (See Table 10 for the applicable weight tolerances.)

Table E-6C—Plain-end Line Pipe Dimensions, Weights per Unit Length, and Test Pressures for Sizes 6⁵/₈ through 80 (SI Units)

(1)	(2)	(3)	(4)	(5)	(6)	(7)	(8)	(9)	(10)	(11)	(12)	(13)	(14)	(15)	
Size	Specified Outside Diameter <i>D</i> (mm)	Specified Wall Thickness <i>t</i> (mm)	Plain-end Weight per Unit Length <i>w_{pe}</i> (kg/m)	Calculated Inside Diameter ^a <i>d</i> (mm)	Minimum Test Pressure ^b (kPa × 100) ^c										
					Grade A	Grade B	Grade X42	Grade X46	Grade X52	Grade X56	Grade X60	Grade X65	Grade X70	Grade X80	
6 ⁵ / ₈ ^d	168.3	2.1	8.61	164.1	Std.	31	36	54	59	67	72	77	84	90	103
					Alt.	39	45	54	59	67	72	77	84	90	103
6 ⁵ / ₈ ^d	168.3	2.8	11.43	162.7	Std.	41	48	72	79	90	96	103	112	121	138
					Alt.	52	60	72	79	90	96	103	112	121	138
6 ⁵ / ₈ ^d	168.3	3.2	13.03	161.9	Std.	47	55	83	90	102	110	118	128	138	157
					Alt.	59	69	83	90	102	110	118	128	138	157
6 ⁵ / ₈ ^d	168.3	3.6	14.62	161.1	Std.	53	62	93	102	115	124	133	144	155	177
					Alt.	66	77	93	102	115	124	133	144	155	177
6 ⁵ / ₈ ^d	168.3	4.0	16.21	160.3	Std.	59	69	103	113	128	138	148	160	172	197
					Alt.	74	86	103	113	128	138	148	160	172	197
6 ⁵ / ₈	168.3	4.4	17.78	159.5	Std.	65	76	114	124	141	151	162	176	189	207
					Alt.	81	95	114	124	141	151	162	176	189	216
6 ⁵ / ₈	168.3	4.8	19.35	158.7	Std.	71	82	124	136	154	165	177	192	207	207
					Alt.	89	103	124	136	154	165	177	192	207	236
6 ⁵ / ₈	168.3	5.2	20.91	157.9	Std.	77	89	134	147	166	179	192	207	207	207
					Alt.	96	112	134	147	166	179	192	208	224	256
6 ⁵ / ₈	168.3	5.6	22.47	157.1	Std.	83	96	145	158	179	193	207	207	207	207
					Alt.	103	120	145	158	179	193	207	224	241	276
6 ⁵ / ₈	168.3	6.4	25.55	155.5	Std.	94	110	165	181	205	207	207	207	207	207
					Alt.	118	137	165	181	205	220	236	256	276	315
6 ⁵ / ₈	168.3	7.1	28.22	154.1	Std.	105	122	184	201	207	207	207	207	207	207
					Alt.	131	153	184	201	227	244	262	283	306	349
6 ⁵ / ₈	168.3	7.9	31.25	152.5	Std.	117	136	204	207	207	207	207	207	207	207
					Alt.	146	170	204	223	253	272	291	315	340	389
6 ⁵ / ₈	168.3	8.7	34.24	150.9	Std.	128	149	207	207	207	207	207	207	207	207
					Alt.	161	187	225	246	278	299	321	347	375	428
6 ⁵ / ₈	168.3	9.5	37.20	149.3	Std.	140	163	207	207	207	207	207	207	207	207
					Alt.	175	193	246	268	304	327	351	379	409	467
6 ⁵ / ₈	168.3	11.0	42.67	146.3	Std.	162	189	207	207	207	207	207	207	207	207
					Alt.	193	193	284	311	352	378	406	439	474	500

Table E-6C—Plain-end Line Pipe Dimensions, Weights per Unit Length, and Test Pressures for Sizes 6⁵/₈ through 80 (SI Units) (Continued)

(1)	(2)	(3)	(4)	(5)	(6)	(7)	(8)	(9)	(10)	(11)	(12)	(13)	(14)	(15)
Size	Specified Outside Diameter <i>D</i> (mm)	Specified Wall Thickness <i>t</i> (mm)	Plain-end Weight per Unit Length <i>w_{pe}</i> (kg/m)	Calculated Inside Diameter ^a <i>d</i> (mm)	Minimum Test Pressure ^b (kPa × 100) ^c									
					Grade A	Grade B	Grade X42	Grade X46	Grade X52	Grade X56	Grade X60	Grade X65	Grade X70	Grade X80
6 ⁵ / ₈	168.3	12.7	48.73	142.9	Std.	187	193	207	207	207	207	207	207	207
					Alt.	193	193	328	359	406	437	469	500	500
6 ⁵ / ₈	168.3	14.3	54.31	139.7	Std.	193	193	207	207	207	207	207	207	207
					Alt.	193	193	370	404	458	492	500	500	500
6 ⁵ / ₈	168.3	15.9	59.76	136.5	Std.	193	193	207	207	207	207	207	207	207
					Alt.	193	193	411	449	500	500	500	500	500
6 ⁵ / ₈	168.3	18.3	67.69	131.7	Std.	193	193	207	207	207	207	207	207	207
					Alt.	193	193	473	500	500	500	500	500	500
6 ⁵ / ₈	168.3	19.1	70.27	130.1	Std.	193	193	207	207	207	207	207	207	207
					Alt.	193	193	494	500	500	500	500	500	500
6 ⁵ / ₈	168.3	21.9	79.06	124.5	Std.	193	193	207	207	207	207	207	207	207
					Alt.	193	193	500	500	500	500	500	500	500
6 ⁵ / ₈	168.3	22.2	79.98	123.9	Std.	193	193	207	207	207	207	207	207	207
					Alt.	193	193	500	500	500	500	500	500	500
8 ⁵ / ₈ ^d	219.1	3.2	17.04	212.7	Std.	36	42	64	69	79	85	91	98	106
					Alt.	45	53	64	69	79	85	91	98	106
8 ⁵ / ₈ ^d	219.1	4.0	21.22	211.1	Std.	45	53	79	87	98	106	113	123	132
					Alt.	57	66	79	87	98	106	113	123	132
8 ⁵ / ₈	219.1	4.8	25.37	209.5	Std.	54	63	95	104	118	127	136	147	159
					Alt.	68	79	95	104	118	127	136	147	159
8 ⁵ / ₈	219.1	5.2	27.43	208.7	Std.	59	69	103	113	128	137	147	159	172
					Alt.	74	86	103	113	128	137	147	159	172
8 ⁵ / ₈	219.1	5.6	29.48	207.9	Std.	63	74	111	122	138	148	159	172	185
					Alt.	79	92	111	122	138	148	159	172	185
8 ⁵ / ₈	219.1	6.4	33.57	206.3	Std.	73	84	127	139	157	169	181	196	207
					Alt.	91	106	127	139	157	169	181	196	212
8 ⁵ / ₈	219.1	7.0	36.61	205.1	Std.	79	92	139	152	172	185	198	207	207
					Alt.	99	115	139	152	172	185	198	215	231
8 ⁵ / ₈	219.1	7.9	41.14	203.3	Std.	90	104	157	171	194	207	207	207	207
					Alt.	112	130	157	171	194	209	224	242	261
8 ⁵ / ₈	219.1	8.2	42.65	202.7	Std.	93	108	163	178	202	207	207	207	207
					Alt.	116	135	163	178	202	217	232	252	271
8 ⁵ / ₈	219.1	8.7	45.14	201.7	Std.	99	115	173	189	207	207	207	207	207
					Alt.	123	144	173	189	214	230	247	267	288
8 ⁵ / ₈	219.1	9.5	49.10	200.1	Std.	108	125	189	206	207	207	207	207	207
					Alt.	135	157	189	206	233	251	269	291	314
8 ⁵ / ₈	219.1	11.1	56.94	196.9	Std.	126	147	207	207	207	207	207	207	207
					Alt.	157	183	220	241	273	293	315	340	367
8 ⁵ / ₈	219.1	12.7	64.64	193.7	Std.	144	168	207	207	207	207	207	207	207
					Alt.	180	193	252	276	312	336	360	390	420
8 ⁵ / ₈	219.1	14.3	72.22	190.5	Std.	162	189	207	207	207	207	207	207	207
					Alt.	193	193	284	310	351	378	405	439	473
8 ⁵ / ₈	219.1	15.9	79.67	187.3	Std.	180	193	207	207	207	207	207	207	207
					Alt.	193	193	316	345	391	420	451	488	500
8 ⁵ / ₈	219.1	18.3	90.62	182.5	Std.	193	193	207	207	207	207	207	207	207
					Alt.	193	193	363	397	450	484	500	500	500
8 ⁵ / ₈	219.1	19.1	94.20	180.9	Std.	193	193	207	207	207	207	207	207	207
					Alt.	193	193	379	415	469	500	500	500	500
8 ⁵ / ₈	219.1	20.6	100.84	177.9	Std.	193	193	207	207	207	207	207	207	207
					Alt.	193	193	409	447	500	500	500	500	500

Table E-6C—Plain-end Line Pipe Dimensions, Weights per Unit Length, and Test Pressures for Sizes 6⁵/₈ through 80 (SI Units) (Continued)

(1) Size	(2) Specified Outside Diameter <i>D</i> (mm)	(3) Specified Wall Thickness <i>t</i> (mm)	(4) Plain-end Weight per Unit Length <i>w_{pe}</i> (kg/m)	(5) Calculated Inside Diameter ^a <i>d</i> (mm)		(6) through (15)									
						Minimum Test Pressure ^b (kPa × 100) ^c									
						Grade A	Grade B	Grade X42	Grade X46	Grade X52	Grade X56	Grade X60	Grade X65	Grade X70	Grade X80
8 ⁵ / ₈	219.1	22.2	107.79	174.7	Std.	193	193	207	207	207	207	207	207	207	207
					Alt.	193	193	441	482	500	500	500	500	500	500
8 ⁵ / ₈	219.1	25.4	121.33	168.3	Std.	193	193	207	207	207	207	207	207	207	207
					Alt.	193	193	500	500	500	500	500	500	500	500
10 ³ / ₄ ^d	273.1	4.0	26.54	265.1	Std.	36	42	72	79	89	96	103	112	120	137
					Alt.	45	53	72	79	89	96	103	112	120	137
10 ³ / ₄ ^d	273.1	4.8	31.76	263.5	Std.	44	51	87	95	107	115	124	134	144	165
					Alt.	55	64	87	95	107	115	124	134	144	165
10 ³ / ₄ ^d	273.1	5.2	34.35	262.7	Std.	47	55	94	103	116	125	134	145	156	179
					Alt.	59	69	94	103	116	125	134	145	156	179
10 ³ / ₄	273.1	5.6	36.94	261.9	Std.	51	59	101	111	125	135	144	156	168	192
					Alt.	64	74	101	111	125	135	144	156	168	192
10 ³ / ₄	273.1	6.4	42.09	260.3	Std.	58	68	116	126	143	154	165	178	192	207
					Alt.	73	85	116	126	143	154	165	178	192	220
10 ³ / ₄	273.1	7.1	46.57	258.9	Std.	65	75	128	140	159	171	183	198	207	207
					Alt.	81	94	128	140	159	171	183	198	213	244
10 ³ / ₄	273.1	7.8	51.03	257.5	Std.	71	83	141	154	174	187	201	207	207	207
					Alt.	89	103	141	154	174	187	201	218	235	268
10 ³ / ₄	273.1	8.7	56.72	255.7	Std.	79	92	157	172	194	207	207	207	207	207
					Alt.	99	115	157	172	194	209	224	243	262	299
10 ³ / ₄	273.1	9.3	60.50	254.5	Std.	85	98	168	184	207	207	207	207	207	207
					Alt.	106	123	168	184	208	223	240	259	280	320
10 ³ / ₄	273.1	11.1	71.72	250.9	Std.	101	118	200	207	207	207	207	207	207	207
					Alt.	126	147	200	219	248	267	286	310	334	381
10 ³ / ₄	273.1	12.7	81.55	247.7	Std.	116	134	207	207	207	207	207	207	207	207
					Alt.	144	168	229	251	284	305	327	354	382	436
10 ³ / ₄	273.1	14.3	91.26	244.5	Std.	130	151	207	207	207	207	207	207	207	207
					Alt.	163	189	258	282	320	344	369	399	430	491
10 ³ / ₄	273.1	15.9	100.85	241.3	Std.	145	168	207	207	207	207	207	207	207	207
					Alt.	181	193	287	314	355	382	410	443	478	500
10 ³ / ₄	273.1	18.3	114.99	236.5	Std.	166	193	207	207	207	207	207	207	207	207
					Alt.	193	193	330	361	409	440	472	500	500	500
10 ³ / ₄	273.1	20.6	128.27	231.9	Std.	187	193	207	207	207	207	207	207	207	207
					Alt.	193	193	372	406	460	495	500	500	500	500
10 ³ / ₄	273.1	22.2	137.36	228.7	Std.	193	193	207	207	207	207	207	207	207	207
					Alt.	193	193	401	438	496	500	500	500	500	500
10 ³ / ₄	273.1	23.8	146.32	225.5	Std.	193	193	207	207	207	207	207	207	207	207
					Alt.	193	193	430	470	500	500	500	500	500	500
10 ³ / ₄	273.1	25.4	155.15	222.3	Std.	193	193	207	207	207	207	207	207	207	207
					Alt.	193	193	459	500	500	500	500	500	500	500
10 ³ / ₄	273.1	31.8	189.22	209.5	Std.	193	193	207	207	207	207	207	207	207	207
					Alt.	193	193	500	500	500	500	500	500	500	500
12 ³ / ₄ ^d	323.9	4.4	34.67	315.1	Std.	34	39	67	73	83	89	96	103	112	127
					Alt.	42	49	67	73	83	89	96	103	112	127
12 ³ / ₄ ^d	323.9	4.8	37.77	314.3	Std.	37	43	73	80	90	97	104	113	122	139
					Alt.	46	54	73	80	90	97	104	113	122	139
12 ³ / ₄ ^d	323.9	5.2	40.87	313.5	Std.	40	46	79	87	98	105	113	122	132	151
					Alt.	50	58	79	87	98	105	113	122	132	151
12 ³ / ₄ ^d	323.9	5.6	43.96	312.7	Std.	43	50	85	93	106	113	122	132	142	162
					Alt.	54	63	85	93	106	113	122	132	142	162

Table E-6C—Plain-end Line Pipe Dimensions, Weights per Unit Length, and Test Pressures for Sizes 6⁵/₈ through 80 (SI Units) (Continued)

(1)	(2)	(3)	(4)	(5)	(6)	(7)	(8)	(9)	(10)	(11)	(12)	(13)	(14)	(15)	
Size	Specified Outside Diameter <i>D</i> (mm)	Specified Wall Thickness <i>t</i> (mm)	Plain-end Weight per Unit Length <i>w_{pe}</i> (kg/m)	Calculated Inside Diameter ^a <i>d</i> (mm)	Minimum Test Pressure ^b (kPa × 100) ^c										
					Grade A	Grade B	Grade X42	Grade X46	Grade X52	Grade X56	Grade X60	Grade X65	Grade X70	Grade X80	
12 ³ / ₄	323.9	6.4	50.11	311.1	Std.	49	57	97	106	121	130	139	150	162	185
					Alt.	61	71	97	106	121	130	139	150	162	185
12 ³ / ₄	323.9	7.1	55.47	309.7	Std.	54	63	108	118	134	144	154	167	180	206
					Alt.	68	79	108	118	134	144	154	167	180	206
12 ³ / ₄	323.9	7.9	61.56	308.1	Std.	61	71	120	131	149	160	172	186	200	207
					Alt.	76	88	120	131	149	160	172	186	200	229
12 ³ / ₄	323.9	8.4	65.35	307.1	Std.	64	75	128	140	158	170	183	198	207	207
					Alt.	81	94	128	140	158	170	183	198	213	243
12 ³ / ₄	323.9	8.7	67.62	306.5	Std.	67	78	132	145	164	176	189	205	207	207
					Alt.	83	97	132	145	164	176	189	205	221	252
12 ³ / ₄	323.9	9.5	73.65	304.9	Std.	73	85	145	158	179	192	206	207	207	207
					Alt.	91	106	145	158	179	192	206	223	241	275
12 ³ / ₄	323.9	10.3	79.65	303.3	Std.	79	92	157	171	194	207	207	207	207	207
					Alt.	99	115	157	171	194	209	224	242	261	298
12 ³ / ₄	323.9	11.1	85.62	301.7	Std.	85	99	169	185	207	207	207	207	207	207
					Alt.	106	124	169	185	209	225	241	261	281	322
12 ³ / ₄	323.9	12.7	97.46	298.5	Std.	97	113	193	207	207	207	207	207	207	207
					Alt.	122	142	193	211	239	257	276	299	322	368
12 ³ / ₄	323.9	14.3	109.18	295.3	Std.	110	128	207	207	207	207	207	207	207	207
					Alt.	137	160	218	238	269	290	311	336	363	414
12 ³ / ₄	323.9	15.9	120.76	292.1	Std.	122	142	207	207	207	207	207	207	207	207
					Alt.	152	177	242	265	300	322	345	374	403	461
12 ³ / ₄	323.9	17.5	132.23	288.9	Std.	134	156	207	207	207	207	207	207	207	207
					Alt.	168	193	266	291	330	355	380	411	444	500
12 ³ / ₄	323.9	19.1	143.56	285.7	Std.	146	171	207	207	207	207	207	207	207	207
					Alt.	183	193	291	318	360	387	415	449	484	500
12 ³ / ₄	323.9	20.6	154.08	282.7	Std.	158	184	207	207	207	207	207	207	207	207
					Alt.	193	193	314	343	388	417	448	484	500	500
12 ³ / ₄	323.9	22.2	165.17	279.5	Std.	170	193	207	207	207	207	207	207	207	207
					Alt.	193	193	338	369	418	450	482	500	500	500
12 ³ / ₄	323.9	23.8	176.13	276.3	Std.	183	193	207	207	207	207	207	207	207	207
					Alt.	193	193	362	396	448	482	500	500	500	500
12 ³ / ₄	323.9	25.4	186.97	273.1	Std.	193	193	207	207	207	207	207	207	207	207
					Alt.	193	193	387	423	479	500	500	500	500	500
12 ³ / ₄	323.9	27.0	197.68	269.9	Std.	193	193	207	207	207	207	207	207	207	207
					Alt.	193	193	411	449	500	500	500	500	500	500
12 ³ / ₄	323.9	28.6	208.27	266.7	Std.	193	193	207	207	207	207	207	207	207	207
					Alt.	193	193	435	476	500	500	500	500	500	500
12 ³ / ₄	323.9	31.8	229.06	260.3	Std.	193	193	207	207	207	207	207	207	207	207
					Alt.	193	193	484	500	500	500	500	500	500	500
14 ^d	355.6	4.8	41.52	346.0	Std.	34	39	67	73	82	89	95	103	111	127
					Alt.	42	49	67	73	82	89	95	103	111	127
14 ^d	355.6	5.2	44.93	345.2	Std.	36	42	72	79	89	96	103	111	120	137
					Alt.	45	53	72	79	89	96	103	111	120	137
14 ^d	355.6	5.3	45.78	345.0	Std.	37	43	73	80	91	98	105	114	122	140
					Alt.	46	54	73	80	91	98	105	114	122	140
14 ^d	355.6	5.6	48.33	344.4	Std.	39	46	78	85	96	103	111	120	129	148
					Alt.	49	57	78	85	96	103	111	120	129	148
14 ^d	355.6	6.4	55.11	342.8	Std.	45	52	89	97	110	118	127	137	148	169
					Alt.	56	65	89	97	110	118	127	137	148	169

Table E-6C—Plain-end Line Pipe Dimensions, Weights per Unit Length, and Test Pressures for Sizes 6⁵/₈ through 80 (SI Units) (Continued)

(1) Size	(2) Specified Outside Diameter <i>D</i> (mm)	(3) Specified Wall Thickness <i>t</i> (mm)	(4) Plain-end Weight per Unit Length <i>w_{pe}</i> (kg/m)	(5) Calculated Inside Diameter ^a <i>d</i> (mm)	(6) through (15) Minimum Test Pressure ^b (kPa × 100) ^c																			
					Grade A		Grade B		Grade X42		Grade X46		Grade X52		Grade X56		Grade X60		Grade X65		Grade X70		Grade X80	
					Std.	Alt.	Std.	Alt.	Std.	Alt.	Std.	Alt.	Std.	Alt.	Std.	Alt.	Std.	Alt.	Std.	Alt.	Std.	Alt.	Std.	Alt.
14 ^d	355.6	7.1	61.02	341.4	Std.	50	58	98	108	122	131	141	152	164	187									
					Alt.	62	72	98	108	122	131	141	152	164	187									
14	355.6	7.9	67.74	339.8	Std.	55	64	110	120	136	146	156	169	182	207									
					Alt.	69	80	110	120	136	146	156	169	182	208									
14	355.6	8.7	74.42	338.2	Std.	61	71	121	132	149	161	172	186	201	207									
					Alt.	76	88	121	132	149	161	172	186	201	230									
14	355.6	9.5	81.08	336.6	Std.	66	77	132	144	163	175	188	203	207	207									
					Alt.	83	97	132	144	163	175	188	203	219	251									
14	355.6	10.3	87.71	335.0	Std.	72	84	143	156	177	190	204	207	207	207									
					Alt.	90	105	143	156	177	190	204	221	238	272									
14	355.6	11.1	94.30	333.4	Std.	78	90	154	168	191	205	207	207	207	207									
					Alt.	97	113	154	168	191	205	220	238	256	293									
14	355.6	11.9	100.86	331.8	Std.	83	97	165	180	204	207	207	207	207	207									
					Alt.	104	121	165	180	204	220	236	255	275	314									
14	355.6	12.7	107.39	330.2	Std.	89	103	176	192	207	207	207	207	207	207									
					Alt.	111	129	176	192	218	234	251	272	293	335									
14	355.6	14.3	120.36	327.0	Std.	100	116	198	207	207	207	207	207	207	207									
					Alt.	125	145	198	217	245	264	283	306	330	377									
14	355.6	15.9	133.19	323.8	Std.	111	129	207	207	207	207	207	207	207	207									
					Alt.	139	162	220	241	273	293	315	341	367	420									
14	355.6	17.5	145.91	320.6	Std.	122	142	207	207	207	207	207	207	207	207									
					Alt.	153	178	243	265	300	323	346	375	404	462									
14	355.6	19.1	158.49	317.4	Std.	133	155	207	207	207	207	207	207	207	207									
					Alt.	167	193	265	289	328	352	378	409	441	500									
14	355.6	20.6	170.18	314.4	Std.	144	168	207	207	207	207	207	207	207	207									
					Alt.	180	193	286	312	354	380	408	441	476	500									
14	355.6	22.2	182.52	311.2	Std.	155	181	207	207	207	207	207	207	207	207									
					Alt.	193	193	308	336	381	410	439	475	500	500									
14	355.6	23.8	194.74	308.0	Std.	166	193	207	207	207	207	207	207	207	207									
					Alt.	193	193	330	361	408	439	471	500	500	500									
14	355.6	25.4	206.83	304.8	Std.	177	193	207	207	207	207	207	207	207	207									
					Alt.	193	193	352	385	436	469	500	500	500	500									
14	355.6	27.0	218.79	301.6	Std.	189	193	207	207	207	207	207	207	207	207									
					Alt.	193	193	374	409	463	498	500	500	500	500									
14	355.6	28.6	230.63	298.4	Std.	193	193	207	207	207	207	207	207	207	207									
					Alt.	193	193	397	433	491	500	500	500	500	500									
14	355.6	31.8	253.92	292.0	Std.	193	193	207	207	207	207	207	207	207	207									
					Alt.	193	193	441	482	500	500	500	500	500	500									
16 ^d	406.4	4.8	47.54	396.8	Std.	29	34	58	64	72	78	83	90	97	111									
					Alt.	37	43	58	64	72	78	83	90	97	111									
16 ^d	406.4	5.2	51.45	396.0	Std.	32	37	63	69	78	84	90	97	105	120									
					Alt.	40	46	63	69	78	84	90	97	105	120									
16 ^d	406.4	5.6	55.35	395.2	Std.	34	40	68	74	84	90	97	105	113	129									
					Alt.	43	50	68	74	84	90	97	105	113	129									
16 ^d	406.4	6.4	63.13	393.6	Std.	39	46	78	85	96	103	111	120	129	148									
					Alt.	49	57	78	85	96	103	111	120	129	148									
16 ^d	406.4	7.1	69.91	392.2	Std.	43	51	86	94	107	115	123	133	143	164									
					Alt.	54	63	86	94	107	115	123	133	143	164									
16	406.4	7.9	77.63	390.6	Std.	48	56	96	105	119	128	137	148	160	182									
					Alt.	60	70	96	105	119	128	137	148	160	182									

Table E-6C—Plain-end Line Pipe Dimensions, Weights per Unit Length, and Test Pressures for Sizes 6⁵/₈ through 80 (SI Units) (Continued)

(1) Size	(2) Specified Outside Diameter <i>D</i> (mm)	(3) Specified Wall Thickness <i>t</i> (mm)	(4) Plain-end Weight per Unit Length <i>w_{pe}</i> (kg/m)	(5) Calculated Inside Diameter ^a <i>d</i> (mm)		(6)	(7)	(8)	(9)	(10)	(11)	(12)	(13)	(14)	(15)
						Minimum Test Pressure ^b (kPa × 100) ^c									
						Grade A	Grade B	Grade X42	Grade X46	Grade X52	Grade X56	Grade X60	Grade X65	Grade X70	Grade X80
16	406.4	8.7	85.32	389.0	Std.	53	62	106	115	131	140	151	163	176	201
					Alt.	66	77	106	115	131	140	151	163	176	201
16	406.4	9.5	92.98	387.4	Std.	58	68	115	126	143	153	165	178	192	207
					Alt.	73	85	115	126	143	153	165	178	192	219
16	406.4	10.3	100.61	385.8	Std.	63	73	125	137	155	166	178	193	207	207
					Alt.	79	92	125	137	155	166	178	193	208	238
16	406.4	11.1	108.20	384.2	Std.	68	79	135	147	167	179	192	207	207	207
					Alt.	85	99	135	147	167	179	192	208	224	250
16	406.4	11.9	115.77	382.6	Std.	73	85	144	158	179	192	206	207	207	207
					Alt.	91	106	144	158	179	192	206	223	240	250
16	406.4	12.7	123.30	381.0	Std.	78	90	154	168	191	205	207	207	207	207
					Alt.	97	113	154	168	191	205	220	238	250	250
16	406.4	14.3	138.27	377.8	Std.	87	102	173	190	207	207	207	207	207	207
					Alt.	109	127	173	190	215	231	248	250	250	250
16	406.4	15.9	153.11	374.6	Std.	97	113	193	207	207	207	207	207	207	207
					Alt.	121	141	193	211	239	250	250	250	250	250
16	406.4	17.5	167.83	371.4	Std.	107	125	207	207	207	207	207	207	207	207
					Alt.	134	156	212	232	250	250	250	250	250	250
16	406.4	19.1	182.42	368.2	Std.	117	136	207	207	207	207	207	207	207	207
					Alt.	146	170	232	250	250	250	250	250	250	250
16	406.4	20.6	195.98	365.2	Std.	126	147	207	207	207	207	207	207	207	207
					Alt.	157	183	250	250	250	250	250	250	250	250
16	406.4	22.2	210.33	362.0	Std.	136	158	207	207	207	207	207	207	207	207
					Alt.	170	193	250	250	250	250	250	250	250	250
16	406.4	23.8	224.55	358.8	Std.	145	169	207	207	207	207	207	207	207	207
					Alt.	182	193	250	250	250	250	250	250	250	250
16	406.4	25.4	238.64	355.6	Std.	155	181	207	207	207	207	207	207	207	207
					Alt.	193	193	250	250	250	250	250	250	250	250
16	406.4	27.0	252.61	352.4	Std.	165	192	207	207	207	207	207	207	207	207
					Alt.	193	193	250	250	250	250	250	250	250	250
16	406.4	28.6	266.45	349.2	Std.	175	193	207	207	207	207	207	207	207	207
					Alt.	193	193	250	250	250	250	250	250	250	250
16	406.4	30.2	280.17	346.0	Std.	185	193	207	207	207	207	207	207	207	207
					Alt.	193	193	250	250	250	250	250	250	250	250
16	406.4	31.8	293.76	342.8	Std.	193	193	207	207	207	207	207	207	207	207
					Alt.	193	193	250	250	250	250	250	250	250	250
18 ^d	457.0	4.8	53.53	447.4	Std.	26	30	52	57	64	69	74	80	86	99
					Alt.	33	38	52	57	64	69	74	80	86	99
18 ^d	457.0	5.6	62.34	445.8	Std.	30	35	60	66	75	80	86	93	101	115
					Alt.	38	44	60	66	75	80	86	93	101	115
18 ^d	457.0	6.4	71.12	444.2	Std.	35	41	69	75	85	92	99	107	115	131
					Alt.	43	51	69	75	85	92	99	107	115	131
18 ^d	457.0	7.1	78.77	442.8	Std.	39	45	77	84	95	102	109	118	128	146
					Alt.	48	56	77	84	95	102	109	118	128	146
18	457.0	7.9	87.49	441.2	Std.	43	50	85	93	106	113	122	132	142	162
					Alt.	54	62	85	93	106	113	122	132	142	162
18	457.0	8.7	96.18	439.6	Std.	47	55	94	103	116	125	134	145	156	179
					Alt.	59	69	94	103	116	125	134	145	156	179
18	457.0	9.5	104.84	438.0	Std.	52	60	102	112	127	136	146	158	171	195
					Alt.	65	75	102	112	127	136	146	158	171	195

Table E-6C—Plain-end Line Pipe Dimensions, Weights per Unit Length, and Test Pressures for Sizes 6⁵/₈ through 80 (SI Units) (Continued)

(1)	(2)	(3)	(4)	(5)	(6)	(7)	(8)	(9)	(10)	(11)	(12)	(13)	(14)	(15)	
Size	Specified Outside Diameter <i>D</i> (mm)	Specified Wall Thickness <i>t</i> (mm)	Plain-end Weight per Unit Length <i>w_{pe}</i> (kg/m)	Calculated Inside Diameter ^a <i>d</i> (mm)	Minimum Test Pressure ^b (kPa × 100) ^c										
					Grade A	Grade B	Grade X42	Grade X46	Grade X52	Grade X56	Grade X60	Grade X65	Grade X70	Grade X80	
18	457.0	10.3	113.46	436.4	Std.	56	65	111	121	138	148	159	172	185	207
					Alt.	70	81	111	121	138	148	159	172	185	211
18	457.0	11.1	122.05	434.8	Std.	60	70	120	131	148	159	171	185	199	207
					Alt.	75	88	120	131	148	159	171	185	199	228
18	457.0	11.9	130.62	433.2	Std.	65	75	128	140	159	171	183	198	207	207
					Alt.	81	94	128	140	159	171	183	198	214	244
18	457.0	12.7	139.15	431.6	Std.	69	80	137	150	170	182	196	207	207	207
					Alt.	86	100	137	150	170	182	196	212	228	250
18	457.0	14.3	156.11	428.4	Std.	78	90	154	169	191	205	207	207	207	207
					Alt.	97	113	154	169	191	205	220	238	250	250
18	457.0	15.9	172.95	425.2	Std.	86	101	172	187	207	207	207	207	207	207
					Alt.	108	126	172	187	212	228	245	250	250	250
18	457.0	17.5	189.67	422.0	Std.	95	111	189	206	207	207	207	207	207	207
					Alt.	119	138	189	206	234	250	250	250	250	250
18	457.0	19.1	206.25	418.8	Std.	104	121	206	207	207	207	207	207	207	207
					Alt.	130	151	206	225	250	250	250	250	250	250
18	457.0	20.6	221.69	415.8	Std.	112	130	207	207	207	207	207	207	207	207
					Alt.	140	163	222	243	250	250	250	250	250	250
18	457.0	22.2	238.03	412.6	Std.	121	140	207	207	207	207	207	207	207	207
					Alt.	151	176	239	250	250	250	250	250	250	250
18	457.0	23.8	254.25	409.4	Std.	129	151	207	207	207	207	207	207	207	207
					Alt.	162	188	250	250	250	250	250	250	250	250
18	457.0	25.4	270.34	406.2	Std.	138	161	207	207	207	207	207	207	207	207
					Alt.	173	193	250	250	250	250	250	250	250	250
18	457.0	27.0	286.30	403.0	Std.	147	171	207	207	207	207	207	207	207	207
					Alt.	183	193	250	250	250	250	250	250	250	250
18	457.0	28.6	302.14	399.8	Std.	155	181	207	207	207	207	207	207	207	207
					Alt.	193	193	250	250	250	250	250	250	250	250
18	457.0	30.2	317.85	396.6	Std.	164	191	207	207	207	207	207	207	207	207
					Alt.	193	193	250	250	250	250	250	250	250	250
18	457.0	31.8	333.44	393.4	Std.	173	193	207	207	207	207	207	207	207	207
					Alt.	193	193	250	250	250	250	250	250	250	250
20 ^d	508.0	5.6	69.38	496.8	Std.	27	32	58	63	71	77	82	89	96	110
					Alt.	34	40	58	63	71	77	82	89	96	110
20 ^d	508.0	6.4	79.16	495.2	Std.	31	36	66	72	81	88	94	102	110	125
					Alt.	39	46	66	72	81	88	94	102	110	125
20 ^d	508.0	7.1	87.70	493.8	Std.	35	40	73	80	90	97	104	113	122	139
					Alt.	43	51	73	80	90	97	104	113	122	139
20	508.0	7.9	97.43	492.2	Std.	39	45	81	89	100	108	116	125	135	155
					Alt.	48	56	81	89	100	108	116	125	135	155
20	508.0	8.7	107.12	490.6	Std.	43	50	89	98	111	119	128	138	149	170
					Alt.	53	62	89	98	111	119	128	138	149	170
20	508.0	9.5	116.78	489.0	Std.	46	54	98	107	121	130	139	151	163	186
					Alt.	58	68	98	107	121	130	139	151	163	186
20	508.0	10.3	126.41	487.4	Std.	50	59	106	116	131	141	151	164	176	201
					Alt.	63	73	106	116	131	141	151	164	176	201
20	508.0	11.1	136.01	485.8	Std.	54	63	114	125	141	152	163	176	190	207
					Alt.	68	79	114	125	141	152	163	176	190	217
20	508.0	11.9	145.58	484.2	Std.	58	68	122	134	151	163	175	189	204	207
					Alt.	73	85	122	134	151	163	175	189	204	233

Table E-6C—Plain-end Line Pipe Dimensions, Weights per Unit Length, and Test Pressures for Sizes 6⁵/₈ through 80 (SI Units) (Continued)

(1) Size	(2) Specified Outside Diameter <i>D</i> (mm)	(3) Specified Wall Thickness <i>t</i> (mm)	(4) Plain-end Weight per Unit Length <i>w_{pe}</i> (kg/m)	(5) Calculated Inside Diameter ^a <i>d</i> (mm)		(6)	(7)	(8)	(9)	(10)	(11)	(12)	(13)	(14)	(15)
						Minimum Test Pressure ^b (kPa × 100) ^c									
						Grade A	Grade B	Grade X42	Grade X46	Grade X52	Grade X56	Grade X60	Grade X65	Grade X70	Grade X80
20	508.0	12.7	155.12	482.6	Std.	62	72	131	143	162	174	186	202	207	207
					Alt.	78	90	131	143	162	174	186	202	217	248
20	508.0	14.3	174.10	479.4	Std.	70	81	147	161	182	196	207	207	207	207
					Alt.	87	102	147	161	182	196	210	227	245	250
20	508.0	15.9	192.95	476.2	Std.	78	91	163	179	202	207	207	207	207	207
					Alt.	97	113	163	179	202	217	233	250	250	250
20	508.0	17.5	216.34	472.2	Std.	88	102	184	201	207	207	207	207	207	207
					Alt.	109	127	184	201	228	245	250	250	250	250
20	508.0	19.1	230.27	469.8	Std.	93	109	196	207	207	207	207	207	207	207
					Alt.	117	136	196	215	243	250	250	250	250	250
20	508.0	20.6	247.60	466.8	Std.	101	117	207	207	207	207	207	207	207	207
					Alt.	126	147	212	231	250	250	250	250	250	250
20	508.0	22.2	265.95	463.6	Std.	109	126	207	207	207	207	207	207	207	207
					Alt.	136	158	228	249	250	250	250	250	250	250
20	508.0	23.8	284.18	460.4	Std.	116	135	207	207	207	207	207	207	207	207
					Alt.	145	169	245	250	250	250	250	250	250	250
20	508.0	25.4	302.28	457.2	Std.	124	145	207	207	207	207	207	207	207	207
					Alt.	155	181	250	250	250	250	250	250	250	250
20	508.0	27.0	320.26	454.0	Std.	132	154	207	207	207	207	207	207	207	207
					Alt.	165	192	250	250	250	250	250	250	250	250
20	508.0	28.6	338.11	450.8	Std.	140	163	207	207	207	207	207	207	207	207
					Alt.	175	193	250	250	250	250	250	250	250	250
20	508.0	30.2	355.83	447.6	Std.	148	172	207	207	207	207	207	207	207	207
					Alt.	185	193	250	250	250	250	250	250	250	250
20	508.0	31.8	373.43	444.4	Std.	155	181	207	207	207	207	207	207	207	207
					Alt.	193	193	250	250	250	250	250	250	250	250
20	508.0	33.3	389.81	441.4	Std.	163	190	207	207	207	207	207	207	207	207
					Alt.	193	193	250	250	250	250	250	250	250	250
20	508.0	34.9	407.17	438.2	Std.	171	193	207	207	207	207	207	207	207	207
					Alt.	193	193	250	250	250	250	250	250	250	250
22 ^d	559.0	5.6	76.42	547.8	Std.	25	29	52	57	65	70	75	81	87	100
					Alt.	31	36	52	57	65	70	75	81	87	100
22 ^d	559.0	6.4	87.21	546.2	Std.	28	33	60	65	74	80	85	92	100	114
					Alt.	36	41	60	65	74	80	85	92	100	114
22 ^d	559.0	7.1	96.63	544.8	Std.	32	37	66	72	82	88	95	102	110	126
					Alt.	39	46	66	72	82	88	95	102	110	126
22	559.0	7.9	107.36	543.2	Std.	35	41	74	81	91	98	105	114	123	140
					Alt.	44	51	74	81	91	98	105	114	123	140
22	559.0	8.7	118.06	541.6	Std.	39	45	81	89	101	108	116	126	135	155
					Alt.	48	56	81	89	101	108	116	126	135	155
22	559.0	9.5	128.73	540.0	Std.	42	49	89	97	110	118	127	137	148	169
					Alt.	53	61	89	97	110	118	127	137	148	169
22	559.0	10.3	139.37	538.4	Std.	46	53	96	105	119	128	137	149	160	183
					Alt.	57	67	96	105	119	128	137	149	160	183
22	559.0	11.1	149.97	536.8	Std.	49	57	104	113	128	138	148	160	173	197
					Alt.	62	72	104	113	128	138	148	160	173	197
22	559.0	11.9	160.55	535.2	Std.	53	62	111	121	138	148	159	172	185	207
					Alt.	66	77	111	121	138	148	159	172	185	212
22	559.0	12.7	171.09	533.6	Std.	56	66	119	130	147	158	169	183	198	207
					Alt.	71	82	119	130	147	158	169	183	198	226

Table E-6C—Plain-end Line Pipe Dimensions, Weights per Unit Length, and Test Pressures for Sizes 6⁵/₈ through 80 (SI Units) (Continued)

(1) Size	(2) Specified Outside Diameter <i>D</i> (mm)	(3) Specified Wall Thickness <i>t</i> (mm)	(4) Plain-end Weight per Unit Length <i>w_{pe}</i> (kg/m)	(5) Calculated Inside Diameter ^a <i>d</i> (mm)	(6) through (15)										
					Minimum Test Pressure ^b (kPa × 100) ^c										
					Grade A	Grade B	Grade X42	Grade X46	Grade X52	Grade X56	Grade X60	Grade X65	Grade X70	Grade X80	
22	559.0	14.3	192.08	530.4	Std.	64	74	134	146	165	178	191	206	207	207
					Alt.	79	92	134	146	165	178	191	206	222	250
22	559.0	15.9	212.95	527.2	Std.	71	82	148	162	184	198	207	207	207	207
					Alt.	88	103	148	162	184	198	212	229	247	250
22	559.0	17.5	233.68	524.0	Std.	78	91	163	179	202	207	207	207	207	207
					Alt.	97	113	163	179	202	218	233	250	250	250
22	559.0	19.1	254.30	520.8	Std.	85	99	178	195	207	207	207	207	207	207
					Alt.	106	124	178	195	221	237	250	250	250	250
22	559.0	20.6	273.51	517.8	Std.	92	107	192	207	207	207	207	207	207	207
					Alt.	114	133	192	210	238	250	250	250	250	250
22	559.0	22.2	293.87	514.6	Std.	99	115	207	207	207	207	207	207	207	207
					Alt.	123	144	207	227	250	250	250	250	250	250
22	559.0	23.8	314.11	511.4	Std.	106	123	207	207	207	207	207	207	207	207
					Alt.	132	154	222	243	250	250	250	250	250	250
22	559.0	25.4	334.23	508.2	Std.	113	131	207	207	207	207	207	207	207	207
					Alt.	141	164	237	250	250	250	250	250	250	250
22	559.0	27.0	354.22	505.0	Std.	120	140	207	207	207	207	207	207	207	207
					Alt.	150	175	250	250	250	250	250	250	250	250
22	559.0	28.6	374.08	501.8	Std.	127	148	207	207	207	207	207	207	207	207
					Alt.	159	185	250	250	250	250	250	250	250	250
22	559.0	30.2	393.81	498.6	Std.	134	156	207	207	207	207	207	207	207	207
					Alt.	168	193	250	250	250	250	250	250	250	250
22	559.0	31.8	413.42	495.4	Std.	141	165	207	207	207	207	207	207	207	207
					Alt.	177	193	250	250	250	250	250	250	250	250
22	559.0	33.3	431.69	492.4	Std.	148	172	207	207	207	207	207	207	207	207
					Alt.	185	193	250	250	250	250	250	250	250	250
22	559.0	34.9	451.06	489.2	Std.	155	181	207	207	207	207	207	207	207	207
					Alt.	193	193	250	250	250	250	250	250	250	250
22	559.0	36.5	470.30	486.0	Std.	162	189	207	207	207	207	207	207	207	207
					Alt.	193	193	250	250	250	250	250	250	250	250
22	559.0	38.1	489.41	482.8	Std.	169	193	207	207	207	207	207	207	207	207
					Alt.	193	193	250	250	250	250	250	250	250	250
24 ^d	610.0	6.4	95.26	597.2	Std.	26	30	55	60	68	73	78	85	91	104
					Alt.	33	38	55	60	68	73	78	85	91	104
24 ^d	610.0	7.1	105.56	595.8	Std.	29	34	61	66	75	81	87	94	101	116
					Alt.	36	42	61	66	75	81	87	94	101	116
24	610.0	7.9	117.30	594.2	Std.	32	37	68	74	84	90	97	104	113	129
					Alt.	40	47	68	74	84	90	97	104	113	129
24	610.0	8.7	129.00	592.6	Std.	35	41	74	81	92	99	106	115	124	142
					Alt.	44	52	74	81	92	99	106	115	124	142
24	610.0	9.5	140.68	591.0	Std.	39	45	81	89	101	108	116	126	135	155
					Alt.	48	56	81	89	101	108	116	126	135	155
24	610.0	10.3	152.32	589.4	Std.	42	49	88	96	109	117	126	136	147	168
					Alt.	52	61	88	96	109	117	126	136	147	168
24	610.0	11.1	163.93	587.8	Std.	45	53	95	104	118	126	136	147	158	181
					Alt.	57	66	95	104	118	126	136	147	158	181
24	610.0	11.9	175.51	586.2	Std.	48	56	102	111	126	136	145	157	170	194
					Alt.	61	71	102	111	126	136	145	157	170	194
24	610.0	12.7	187.06	584.6	Std.	52	60	109	119	135	145	155	168	181	207
					Alt.	65	75	109	119	135	145	155	168	181	207

Table E-6C—Plain-end Line Pipe Dimensions, Weights per Unit Length, and Test Pressures for Sizes 6⁵/₈ through 80 (SI Units) (Continued)

(1) Size	(2) Specified Outside Diameter <i>D</i> (mm)	(3) Specified Wall Thickness <i>t</i> (mm)	(4) Plain-end Weight per Unit Length <i>w_{pe}</i> (kg/m)	(5) Calculated Inside Diameter ^a <i>d</i> (mm)		(6)–(15) Minimum Test Pressure ^b (kPa × 100) ^c									
						Grade A	Grade B	Grade X42	Grade X46	Grade X52	Grade X56	Grade X60	Grade X65	Grade X70	Grade X80
24	610.0	14.3	210.07	581.4	Std.	58	68	122	134	151	163	175	189	204	207
					Alt.	73	85	122	134	151	163	175	189	204	233
24	610.0	15.9	232.94	578.2	Std.	65	75	136	149	168	181	194	207	207	207
					Alt.	81	94	136	149	168	181	194	210	227	250
24	610.0	17.5	255.69	575.0	Std.	71	83	150	164	185	199	207	207	207	207
					Alt.	89	104	150	164	185	199	214	231	249	250
24	610.0	19.1	278.32	571.8	Std.	78	91	163	179	202	207	207	207	207	207
					Alt.	97	113	163	179	202	218	233	250	250	250
24	610.0	20.6	299.41	568.8	Std.	84	98	176	193	207	207	207	207	207	207
					Alt.	105	122	176	193	218	235	250	250	250	250
24	610.0	22.2	321.79	565.6	Std.	90	105	190	207	207	207	207	207	207	207
					Alt.	113	132	190	208	235	250	250	250	250	250
24	610.0	23.8	344.05	562.4	Std.	97	113	204	207	207	207	207	207	207	207
					Alt.	121	141	204	223	250	250	250	250	250	250
24	610.0	25.4	366.17	559.2	Std.	103	120	207	207	207	207	207	207	207	207
					Alt.	129	151	217	238	250	250	250	250	250	250
24	610.0	27.0	388.17	556.0	Std.	110	128	207	207	207	207	207	207	207	207
					Alt.	137	160	231	250	250	250	250	250	250	250
24	610.0	28.6	410.05	552.8	Std.	116	136	207	207	207	207	207	207	207	207
					Alt.	146	169	245	250	250	250	250	250	250	250
24	610.0	30.2	431.80	549.6	Std.	123	143	207	207	207	207	207	207	207	207
					Alt.	154	179	250	250	250	250	250	250	250	250
24	610.0	31.8	453.42	546.4	Std.	129	151	207	207	207	207	207	207	207	207
					Alt.	162	188	250	250	250	250	250	250	250	250
24	610.0	33.3	473.57	543.4	Std.	136	158	207	207	207	207	207	207	207	207
					Alt.	170	193	250	250	250	250	250	250	250	250
24	610.0	34.9	494.95	540.2	Std.	142	165	207	207	207	207	207	207	207	207
					Alt.	178	193	250	250	250	250	250	250	250	250
24	610.0	36.5	516.20	537.0	Std.	149	173	207	207	207	207	207	207	207	207
					Alt.	186	193	250	250	250	250	250	250	250	250
24	610.0	38.1	537.33	533.8	Std.	155	181	207	207	207	207	207	207	207	207
					Alt.	193	193	250	250	250	250	250	250	250	250
24	610.0	39.7	558.32	530.6	Std.	162	188	207	207	207	207	207	207	207	207
					Alt.	193	193	250	250	250	250	250	250	250	250
26 ^d	660.0	6.4	103.15	647.2	Std.	24	28	51	55	63	67	72	78	84	96
					Alt.	30	35	51	55	63	67	72	78	84	96
26 ^d	660.0	7.1	114.31	645.8	Std.	27	31	56	61	70	75	80	87	94	107
					Alt.	33	39	56	61	70	75	80	87	94	107
26	660.0	7.9	127.04	644.2	Std.	30	35	62	68	77	83	89	97	104	119
					Alt.	37	43	62	68	77	83	89	97	104	119
26	660.0	8.7	139.73	642.6	Std.	33	38	69	75	85	92	98	106	115	131
					Alt.	41	48	69	75	85	92	98	106	115	131
26	660.0	9.5	152.39	641.0	Std.	36	42	75	82	93	100	107	116	125	143
					Alt.	45	52	75	82	93	100	107	116	125	143
26	660.0	10.3	165.02	639.4	Std.	39	45	81	89	101	108	116	126	136	155
					Alt.	48	56	81	89	101	108	116	126	136	155
26	660.0	11.1	177.62	637.8	Std.	42	49	88	96	109	117	125	136	146	167
					Alt.	52	61	88	96	109	117	125	136	146	167
26	660.0	11.9	190.19	636.2	Std.	45	52	94	103	117	125	134	145	157	179
					Alt.	56	65	94	103	117	125	134	145	157	179

Table E-6C—Plain-end Line Pipe Dimensions, Weights per Unit Length, and Test Pressures for Sizes 6⁵/₈ through 80 (SI Units) (Continued)

(1)	(2)	(3)	(4)	(5)	(6)	(7)	(8)	(9)	(10)	(11)	(12)	(13)	(14)	(15)	
Size	Specified Outside Diameter <i>D</i> (mm)	Specified Wall Thickness <i>t</i> (mm)	Plain-end Weight per Unit Length <i>w_{pe}</i> (kg/m)	Calculated Inside Diameter ^a <i>d</i> (mm)	Minimum Test Pressure ^b (kPa × 100) ^c										
					Grade A	Grade B	Grade X42	Grade X46	Grade X52	Grade X56	Grade X60	Grade X65	Grade X70	Grade X80	
26	660.0	12.7	202.72	634.6	Std.	48	56	100	110	124	134	143	155	167	191
					Alt.	60	70	100	110	124	134	143	155	167	191
26	660.0	14.3	227.70	631.4	Std.	54	63	113	124	140	151	161	175	188	207
					Alt.	67	78	113	124	140	151	161	175	188	215
26	660.0	15.9	252.55	628.2	Std.	60	70	126	137	156	167	180	194	207	207
					Alt.	75	87	126	137	156	167	180	194	209	239
26	660.0	17.5	277.27	625.0	Std.	66	77	138	151	171	184	198	207	207	207
					Alt.	82	96	138	151	171	184	198	214	231	250
26	660.0	19.1	301.87	621.8	Std.	72	84	151	165	187	201	207	207	207	207
					Alt.	90	105	151	165	187	201	216	233	250	250
26	660.0	20.6	324.81	618.8	Std.	78	90	163	178	202	207	207	207	207	207
					Alt.	97	113	163	178	202	217	233	250	250	250
26	660.0	22.2	349.16	615.6	Std.	84	97	176	192	207	207	207	207	207	207
					Alt.	104	122	176	192	217	234	250	250	250	250
26	660.0	23.8	373.39	612.4	Std.	90	104	188	206	207	207	207	207	207	207
					Alt.	112	130	188	206	233	250	250	250	250	250
26	660.0	25.4	397.49	609.2	Std.	96	111	201	207	207	207	207	207	207	207
					Alt.	119	139	201	220	249	250	250	250	250	250
28 ^d	711.0	6.4	111.20	698.2	Std.	22	26	47	51	58	63	67	73	78	89
					Alt.	28	33	47	51	58	63	67	73	78	89
28 ^d	711.0	7.1	123.24	696.8	Std.	25	29	52	57	65	69	74	81	87	99
					Alt.	31	36	52	57	65	69	74	81	87	99
28	711.0	7.9	136.97	695.2	Std.	28	32	58	63	72	77	83	90	97	110
					Alt.	35	40	58	63	72	77	83	90	97	110
28	711.0	8.7	150.67	693.6	Std.	30	35	64	70	79	85	91	99	106	122
					Alt.	38	44	64	70	79	85	91	99	106	122
28	711.0	9.5	164.34	692.0	Std.	33	39	70	76	86	93	100	108	116	133
					Alt.	41	48	70	76	86	93	100	108	116	133
28	711.0	10.3	177.98	690.4	Std.	36	42	76	83	94	101	108	117	126	144
					Alt.	45	52	76	83	94	101	108	117	126	144
28	711.0	11.1	191.58	688.8	Std.	39	45	81	89	101	108	116	126	136	155
					Alt.	48	56	81	89	101	108	116	126	136	155
28	711.0	11.9	205.15	687.2	Std.	42	48	87	96	108	116	125	135	146	166
					Alt.	52	61	87	96	108	116	125	135	146	166
28	711.0	12.7	218.69	685.6	Std.	44	52	93	102	115	124	133	144	155	177
					Alt.	55	65	93	102	115	124	133	144	155	177
28	711.0	14.3	245.68	682.4	Std.	50	58	105	115	130	140	150	162	175	200
					Alt.	62	73	105	115	130	140	150	162	175	200
28	711.0	15.9	272.54	679.2	Std.	56	65	117	128	145	155	167	180	194	207
					Alt.	69	81	117	128	145	155	167	180	194	222
28	711.0	17.5	299.28	676.0	Std.	61	71	128	140	159	171	183	198	207	207
					Alt.	76	89	128	140	159	171	183	198	214	245
28	711.0	19.1	325.89	672.8	Std.	67	78	140	153	174	187	200	207	207	207
					Alt.	83	97	140	153	174	187	200	217	234	250
28	711.0	20.6	350.72	669.8	Std.	72	84	151	165	187	201	207	207	207	207
					Alt.	90	105	151	165	187	201	216	234	250	250
28	711.0	22.2	377.08	666.6	Std.	78	90	163	178	202	207	207	207	207	207
					Alt.	97	113	163	178	202	217	233	250	250	250
28	711.0	23.8	403.32	663.4	Std.	83	97	175	191	207	207	207	207	207	207
					Alt.	104	121	175	191	216	233	249	250	250	250

Table E-6C—Plain-end Line Pipe Dimensions, Weights per Unit Length, and Test Pressures for Sizes 6⁵/₈ through 80 (SI Units) (Continued)

(1) Size	(2) Specified Outside Diameter <i>D</i> (mm)	(3) Specified Wall Thickness <i>t</i> (mm)	(4) Plain-end Weight per Unit Length <i>w_{pe}</i> (kg/m)	(5) Calculated Inside Diameter ^a <i>d</i> (mm)	(6) through (15) Minimum Test Pressure ^b (kPa × 100) ^c										
					Grade										
					A	B	X42	X46	X52	X56	X60	X65	X70	X80	
28	711.0	25.4	429.44	660.2	Std.	89	103	186	204	207	207	207	207	207	207
					Alt.	111	129	186	204	231	248	250	250	250	250
30 ^d	762.0	6.4	119.25	749.2	Std.	21	24	44	48	54	58	63	68	73	83
					Alt.	26	30	44	48	54	58	63	68	73	83
30 ^d	762.0	7.1	132.17	747.8	Std.	23	27	49	53	60	65	69	75	81	93
					Alt.	29	34	49	53	60	65	69	75	81	93
30	762.0	7.9	146.91	746.2	Std.	26	30	54	59	67	72	77	84	90	103
					Alt.	32	37	54	59	67	72	77	84	90	103
30	762.0	8.7	161.61	744.6	Std.	28	33	60	65	74	79	85	92	99	113
					Alt.	35	41	60	65	74	79	85	92	99	113
30	762.0	9.5	176.29	743.0	Std.	31	36	65	71	81	87	93	101	108	124
					Alt.	39	45	65	71	81	87	93	101	108	124
30	762.0	10.3	190.93	741.4	Std.	34	39	71	77	87	94	101	109	118	134
					Alt.	42	49	71	77	87	94	101	109	118	134
30	762.0	11.1	205.54	739.8	Std.	36	42	76	83	94	101	109	117	127	145
					Alt.	45	53	76	83	94	101	109	117	127	145
30	762.0	11.9	220.12	738.2	Std.	39	45	82	89	101	109	116	126	136	155
					Alt.	48	56	82	89	101	109	116	126	136	155
30	762.0	12.7	234.67	736.6	Std.	41	48	87	95	108	116	124	134	145	166
					Alt.	52	60	87	95	108	116	124	134	145	166
30	762.0	14.3	263.67	733.4	Std.	47	54	98	107	121	130	140	151	163	186
					Alt.	58	68	98	107	121	130	140	151	163	186
30	762.0	15.9	292.54	730.2	Std.	52	60	109	119	135	145	155	168	181	207
					Alt.	65	75	109	119	135	145	155	168	181	207
30	762.0	17.5	321.29	727.0	Std.	57	66	120	131	148	160	171	185	200	207
					Alt.	71	83	120	131	148	160	171	185	200	228
30	762.0	19.1	349.91	723.8	Std.	62	72	131	143	162	174	187	202	207	207
					Alt.	78	91	131	143	162	174	187	202	218	249
30	762.0	20.6	376.63	720.8	Std.	67	78	141	154	175	188	201	207	207	207
					Alt.	84	98	141	154	175	188	201	218	235	250
30	762.0	22.2	405.00	717.6	Std.	72	84	152	166	188	202	207	207	207	207
					Alt.	90	105	152	166	188	202	217	235	250	250
30	762.0	23.8	433.26	714.4	Std.	78	90	163	178	202	207	207	207	207	207
					Alt.	97	113	163	178	202	217	233	250	250	250
30	762.0	25.4	461.38	711.2	Std.	83	96	174	190	207	207	207	207	207	207
					Alt.	104	121	174	190	215	232	248	250	250	250
30	762.0	27.0	489.38	708.0	Std.	88	102	185	202	207	207	207	207	207	207
					Alt.	110	128	185	202	229	246	250	250	250	250
30	762.0	28.6	517.25	704.8	Std.	93	109	196	207	207	207	207	207	207	207
					Alt.	117	136	196	214	243	250	250	250	250	250
30	762.0	30.2	544.99	701.6	Std.	98	115	207	207	207	207	207	207	207	207
					Alt.	123	143	207	226	250	250	250	250	250	250
30	762.0	31.8	572.61	698.4	Std.	104	121	207	207	207	207	207	207	207	207
					Alt.	130	151	218	238	250	250	250	250	250	250
32 ^d	813.0	6.4	127.30	800.2	Std.	20	23	41	45	51	55	59	63	68	78
					Alt.	24	28	41	45	51	55	59	63	68	78
32 ^d	813.0	7.1	141.10	798.8	Std.	22	25	46	50	56	61	65	70	76	87
					Alt.	27	32	46	50	56	61	65	70	76	87
32	813.0	7.9	156.84	797.2	Std.	24	28	51	55	63	68	72	78	84	97
					Alt.	30	35	51	55	63	68	72	78	84	97

Table E-6C—Plain-end Line Pipe Dimensions, Weights per Unit Length, and Test Pressures for Sizes 6⁵/₈ through 80 (SI Units) (Continued)

(1)	(2)	(3)	(4)	(5)	(6)	(7)	(8)	(9)	(10)	(11)	(12)	(13)	(14)	(15)	
Size	Specified Outside Diameter <i>D</i> (mm)	Specified Wall Thickness <i>t</i> (mm)	Plain-end Weight per Unit Length <i>w_{pe}</i> (kg/m)	Calculated Inside Diameter ^a <i>d</i> (mm)	Minimum Test Pressure ^b (kPa × 100) ^c										
					Grade A	Grade B	Grade X42	Grade X46	Grade X52	Grade X56	Grade X60	Grade X65	Grade X70	Grade X80	
32	813.0	8.7	172.56	795.6	Std.	27	31	56	61	69	74	80	86	93	106
					Alt.	33	39	56	61	69	74	80	86	93	106
32	813.0	9.5	188.24	794.0	Std.	29	34	61	67	76	81	87	94	102	116
					Alt.	36	42	61	67	76	81	87	94	102	116
32	813.0	10.3	203.88	792.4	Std.	31	37	66	72	82	88	94	102	110	126
					Alt.	39	46	66	72	82	88	94	102	110	126
32	813.0	11.1	219.50	790.8	Std.	34	39	71	78	88	95	102	110	119	136
					Alt.	42	49	71	78	88	95	102	110	119	136
32	813.0	11.9	235.09	789.2	Std.	36	42	76	84	95	102	109	118	127	145
					Alt.	45	53	76	84	95	102	109	118	127	145
32	813.0	12.7	250.64	787.6	Std.	39	45	82	89	101	109	116	126	136	155
					Alt.	49	56	82	89	101	109	116	126	136	155
32	813.0	14.3	281.65	784.4	Std.	44	51	92	100	114	122	131	142	153	175
					Alt.	55	64	92	100	114	122	131	142	153	175
32	813.0	15.9	312.54	781.2	Std.	49	57	102	112	126	136	146	158	170	194
					Alt.	61	71	102	112	126	136	146	158	170	194
32	813.0	17.5	343.30	778.0	Std.	53	62	112	123	139	150	160	174	187	207
					Alt.	67	78	112	123	139	150	160	174	187	214
32	813.0	19.1	373.93	774.8	Std.	58	68	123	134	152	163	175	189	204	207
					Alt.	73	85	123	134	152	163	175	189	204	233
32	813.0	20.6	402.54	771.8	Std.	63	73	132	145	164	176	189	204	207	207
					Alt.	79	92	132	145	164	176	189	204	220	250
32	813.0	22.2	432.93	768.6	Std.	68	79	143	156	176	190	203	207	207	207
					Alt.	85	99	143	156	176	190	203	220	237	250
32	813.0	23.8	463.19	765.4	Std.	73	85	153	167	189	203	207	207	207	207
					Alt.	91	106	153	167	189	203	218	236	250	250
32	813.0	25.4	493.32	762.2	Std.	78	90	163	178	202	207	207	207	207	207
					Alt.	97	113	163	178	202	217	233	250	250	250
32	813.0	27.0	523.33	759.0	Std.	82	96	173	189	207	207	207	207	207	207
					Alt.	103	120	173	189	215	231	247	250	250	250
32	813.0	28.6	553.22	755.8	Std.	87	102	184	201	207	207	207	207	207	207
					Alt.	109	127	184	201	227	244	250	250	250	250
32	813.0	30.2	582.98	752.6	Std.	92	107	194	207	207	207	207	207	207	207
					Alt.	115	134	194	212	240	250	250	250	250	250
32	813.0	31.8	612.61	749.4	Std.	97	113	204	207	207	207	207	207	207	207
					Alt.	121	141	204	223	250	250	250	250	250	250
34 ^d	864.0	6.4	135.35	851.2	Std.	18	21	39	42	48	51	55	60	64	74
					Alt.	23	27	39	42	48	51	55	60	64	74
34 ^d	864.0	7.1	150.03	849.8	Std.	20	24	43	47	53	57	61	66	71	82
					Alt.	26	30	43	47	53	57	61	66	71	82
34	864.0	7.9	166.78	848.2	Std.	23	26	48	52	59	64	68	74	79	91
					Alt.	28	33	48	52	59	64	68	74	79	91
34	864.0	8.7	183.50	846.6	Std.	25	29	53	57	65	70	75	81	88	100
					Alt.	31	36	53	57	65	70	75	81	88	100
34	864.0	9.5	200.18	845.0	Std.	27	32	57	63	71	76	82	89	96	109
					Alt.	34	40	57	63	71	76	82	89	96	109
34	864.0	10.3	216.84	843.4	Std.	30	34	62	68	77	83	89	96	104	118
					Alt.	37	43	62	68	77	83	89	96	104	118
34	864.0	11.1	233.46	841.8	Std.	32	37	67	73	83	89	96	104	112	128
					Alt.	40	46	67	73	83	89	96	104	112	128

Table E-6C—Plain-end Line Pipe Dimensions, Weights per Unit Length, and Test Pressures for Sizes 6⁵/₈ through 80 (SI Units) (Continued)

(1) Size	(2) Specified Outside Diameter <i>D</i> (mm)	(3) Specified Wall Thickness <i>t</i> (mm)	(4) Plain-end Weight per Unit Length <i>w_{pe}</i> (kg/m)	(5) Calculated Inside Diameter ^a <i>d</i> (mm)	(6)–(15) Minimum Test Pressure ^b (kPa × 100) ^c										
					Grade										
					A	B	X42	X46	X52	X56	X60	X65	X70	X80	
34	864.0	11.9	250.05	840.2	Std.	34	40	72	79	89	96	103	111	120	137
					Alt.	43	50	72	79	89	96	103	111	120	137
34	864.0	12.7	266.61	838.6	Std.	37	43	77	84	95	102	110	119	128	146
					Alt.	46	53	77	84	95	102	110	119	128	146
34	864.0	14.3	299.64	835.4	Std.	41	48	86	94	107	115	123	133	144	164
					Alt.	51	60	86	94	107	115	123	133	144	164
34	864.0	15.9	332.53	832.2	Std.	46	53	96	105	119	128	137	148	160	183
					Alt.	57	67	96	105	119	128	137	148	160	183
34	864.0	17.5	365.31	829.0	Std.	50	59	106	116	131	141	151	163	176	201
					Alt.	63	73	106	116	131	141	151	163	176	201
34	864.0	19.1	397.95	825.8	Std.	55	64	115	126	143	154	165	178	192	207
					Alt.	69	80	115	126	143	154	165	178	192	220
34	864.0	20.6	428.44	822.8	Std.	59	69	124	136	154	166	178	192	207	207
					Alt.	74	86	124	136	154	166	178	192	207	237
34	864.0	22.2	460.85	819.6	Std.	64	74	134	147	166	179	191	207	207	207
					Alt.	80	93	134	147	166	179	191	207	223	250
34	864.0	23.8	493.12	816.4	Std.	68	80	144	157	178	191	205	207	207	207
					Alt.	86	100	144	157	178	191	205	222	239	250
34	864.0	25.4	525.27	813.2	Std.	73	85	153	168	190	204	207	207	207	207
					Alt.	91	106	153	168	190	204	219	237	250	250
34	864.0	27.0	557.29	810.0	Std.	78	90	163	178	202	207	207	207	207	207
					Alt.	97	113	163	178	202	217	233	250	250	250
34	864.0	28.6	589.19	806.8	Std.	82	96	173	189	207	207	207	207	207	207
					Alt.	103	120	173	189	214	230	247	250	250	250
34	864.0	30.2	620.96	803.6	Std.	87	101	182	199	207	207	207	207	207	207
					Alt.	109	126	182	199	226	243	250	250	250	250
34	864.0	31.8	652.60	800.4	Std.	91	106	192	207	207	207	207	207	207	207
					Alt.	114	133	192	210	238	250	250	250	250	250
36 ^d	914.0	6.4	143.24	901.2	Std.	17	20	37	40	45	49	52	56	61	70
					Alt.	22	25	37	40	45	49	52	56	61	70
36 ^d	914.0	7.1	158.79	899.8	Std.	19	22	41	44	50	54	58	63	68	77
					Alt.	24	28	41	44	50	54	58	63	68	77
36	914.0	7.9	176.52	898.2	Std.	21	25	45	49	56	60	64	70	75	86
					Alt.	27	31	45	49	56	60	64	70	75	86
36	914.0	8.7	194.22	896.6	Std.	24	28	50	54	62	66	71	77	83	95
					Alt.	30	34	50	54	62	66	71	77	83	95
36	914.0	9.5	211.90	895.0	Std.	26	30	54	59	67	72	77	84	90	103
					Alt.	32	38	54	59	67	72	77	84	90	103
36	914.0	10.3	229.54	893.4	Std.	28	33	59	64	73	78	84	91	98	112
					Alt.	35	41	59	64	73	78	84	91	98	112
36	914.0	11.1	247.15	891.8	Std.	30	35	63	69	78	84	91	98	106	121
					Alt.	38	44	63	69	78	84	91	98	106	121
36	914.0	11.9	264.72	890.2	Std.	32	38	68	74	84	90	97	105	113	129
					Alt.	40	47	68	74	84	90	97	105	113	129
36	914.0	12.7	282.27	888.6	Std.	35	40	73	79	90	97	104	112	121	138
					Alt.	43	50	73	79	90	97	104	112	121	138
36	914.0	14.3	317.27	885.4	Std.	39	45	82	89	101	109	117	126	136	155
					Alt.	49	57	82	89	101	109	117	126	136	155
36	914.0	15.9	352.14	882.2	Std.	43	50	91	99	112	121	130	140	151	173
					Alt.	54	63	91	99	112	121	130	140	151	173

Table E-6C—Plain-end Line Pipe Dimensions, Weights per Unit Length, and Test Pressures for Sizes 6⁵/₈ through 80 (SI Units) (Continued)

(1)	(2)	(3)	(4)	(5)	(6)	(7)	(8)	(9)	(10)	(11)	(12)	(13)	(14)	(15)	
Size	Specified Outside Diameter <i>D</i> (mm)	Specified Wall Thickness <i>t</i> (mm)	Plain-end Weight per Unit Length <i>w_{pe}</i> (kg/m)	Calculated Inside Diameter ^a <i>d</i> (mm)	Minimum Test Pressure ^b (kPa × 100) ^c										
					Grade A	Grade B	Grade X42	Grade X46	Grade X52	Grade X56	Grade X60	Grade X65	Grade X70	Grade X80	
36	914.0	17.5	386.88	879.0	Std.	48	55	100	109	124	133	143	154	166	190
					Alt.	59	69	100	109	124	133	143	154	166	190
36	914.0	19.1	421.50	875.8	Std.	52	60	109	119	135	145	156	169	182	207
					Alt.	65	76	109	119	135	145	156	169	182	208
36	914.0	20.6	453.84	872.8	Std.	56	65	118	129	146	157	168	182	196	207
					Alt.	70	81	118	129	146	157	168	182	196	224
36	914.0	22.2	488.22	869.6	Std.	60	70	127	139	157	169	181	196	207	207
					Alt.	75	88	127	139	157	169	181	196	211	241
36	914.0	23.8	522.47	866.4	Std.	65	75	136	149	168	181	194	207	207	207
					Alt.	81	94	136	149	168	181	194	210	226	250
36	914.0	25.4	556.59	863.2	Std.	69	80	145	159	180	193	207	207	207	207
					Alt.	86	100	145	159	180	193	207	224	242	250
36	914.0	27.0	590.58	860.0	Std.	73	85	154	169	191	205	207	207	207	207
					Alt.	92	107	154	169	191	205	220	238	250	250
36	914.0	28.6	624.45	856.8	Std.	78	90	163	179	202	207	207	207	207	207
					Alt.	97	113	163	179	202	217	233	250	250	250
36	914.0	30.2	658.19	853.6	Std.	82	96	172	189	207	207	207	207	207	207
					Alt.	103	119	172	189	214	230	246	250	250	250
36	914.0	31.8	691.81	850.4	Std.	86	101	182	199	207	207	207	207	207	207
					Alt.	108	126	182	199	225	242	250	250	250	250
38	965.0	7.9	186.46	949.2	Std.	20	24	43	47	53	57	61	66	71	81
					Alt.	25	30	43	47	53	57	61	66	71	81
38	965.0	8.7	205.17	947.6	Std.	22	26	47	51	58	63	67	73	78	90
					Alt.	28	33	47	51	58	63	67	73	78	90
38	965.0	9.5	223.84	946.0	Std.	24	28	51	56	64	68	73	79	86	98
					Alt.	31	36	51	56	64	68	73	79	86	98
38	965.0	10.3	242.49	944.4	Std.	27	31	56	61	69	74	80	86	93	106
					Alt.	33	39	56	61	69	74	80	86	93	106
38	965.0	11.1	261.11	942.8	Std.	29	33	60	66	74	80	86	93	100	114
					Alt.	36	42	60	66	74	80	86	93	100	114
38	965.0	11.9	279.69	941.2	Std.	31	36	64	70	80	86	92	99	107	123
					Alt.	38	45	64	70	80	86	92	99	107	123
38	965.0	12.7	298.24	939.6	Std.	33	38	69	75	85	91	98	106	114	131
					Alt.	41	48	69	75	85	91	98	106	114	131
38	965.0	14.3	335.25	936.4	Std.	37	43	77	85	96	103	110	119	129	147
					Alt.	46	54	77	85	96	103	110	119	129	147
38	965.0	15.9	372.14	933.2	Std.	41	48	86	94	106	114	123	133	143	164
					Alt.	51	60	86	94	106	114	123	133	143	164
38	965.0	17.5	408.89	930.0	Std.	45	52	95	103	117	126	135	146	158	180
					Alt.	56	66	95	103	117	126	135	146	158	180
38	965.0	19.1	445.52	926.8	Std.	49	57	103	113	128	138	147	160	172	197
					Alt.	61	72	103	113	128	138	147	160	172	197
38	965.0	20.6	479.75	923.8	Std.	53	62	111	122	138	148	159	172	186	207
					Alt.	66	77	111	122	138	148	159	172	186	212
38	965.0	22.2	516.14	920.6	Std.	57	67	120	131	149	160	171	186	200	207
					Alt.	71	83	120	131	149	160	171	186	200	229
38	965.0	23.8	552.40	917.4	Std.	61	71	129	141	159	171	184	199	207	207
					Alt.	77	89	129	141	159	171	184	199	214	245
38	965.0	25.4	588.53	914.2	Std.	65	76	137	150	170	183	196	207	207	207
					Alt.	82	95	137	150	170	183	196	212	229	250

Table E-6C—Plain-end Line Pipe Dimensions, Weights per Unit Length, and Test Pressures for Sizes 6⁵/₈ through 80 (SI Units) (Continued)

(1) Size	(2) Specified Outside Diameter <i>D</i> (mm)	(3) Specified Wall Thickness <i>t</i> (mm)	(4) Plain-end Weight per Unit Length <i>w_{pe}</i> (kg/m)	(5) Calculated Inside Diameter ^a <i>d</i> (mm)		(6)	(7)	(8)	(9)	(10)	(11)	(12)	(13)	(14)	(15)
						Minimum Test Pressure ^b (kPa × 100) ^c									
						Grade A	Grade B	Grade X42	Grade X46	Grade X52	Grade X56	Grade X60	Grade X65	Grade X70	Grade X80
38	965.0	27.0	624.54	911.0	Std.	70	81	146	160	181	194	207	207	207	207
					Alt.	87	101	146	160	181	194	209	226	243	250
38	965.0	28.6	660.42	907.8	Std.	74	86	155	169	192	206	207	207	207	207
					Alt.	92	107	155	169	192	206	221	239	250	250
38	965.0	30.2	696.18	904.6	Std.	78	91	163	179	202	207	207	207	207	207
					Alt.	97	113	163	179	202	217	233	250	250	250
38	965.0	31.8	731.80	901.4	Std.	82	95	172	188	207	207	207	207	207	207
					Alt.	102	119	172	188	213	229	246	250	250	250
40	1016.0	7.9	196.39	1000.2	Std.	19	22	41	44	50	54	58	63	68	77
					Alt.	24	28	41	44	50	54	58	63	68	77
40	1016.0	8.7	216.11	998.6	Std.	21	25	45	49	55	59	64	69	74	85
					Alt.	27	31	45	49	55	59	64	69	74	85
40	1016.0	9.5	235.79	997.0	Std.	23	27	49	53	60	65	70	75	81	93
					Alt.	29	34	49	53	60	65	70	75	81	93
40	1016.0	10.3	255.45	995.4	Std.	25	29	53	58	66	70	76	82	88	101
					Alt.	31	37	53	58	66	70	76	82	88	101
40	1016.0	11.1	275.07	993.8	Std.	27	32	57	62	71	76	81	88	95	109
					Alt.	34	39	57	62	71	76	81	88	95	109
40	1016.0	11.9	294.66	992.2	Std.	29	34	61	67	76	81	87	94	102	116
					Alt.	36	42	61	67	76	81	87	94	102	116
40	1016.0	12.7	314.22	990.6	Std.	31	36	65	71	81	87	93	101	109	124
					Alt.	39	45	65	71	81	87	93	101	109	124
40	1016.0	14.3	353.24	987.4	Std.	35	41	73	80	91	98	105	113	122	140
					Alt.	44	51	73	80	91	98	105	113	122	140
40	1016.0	15.9	392.13	984.2	Std.	39	45	82	89	101	109	117	126	136	155
					Alt.	49	57	82	89	101	109	117	126	136	155
40	1016.0	17.5	430.90	981.0	Std.	43	50	90	98	111	120	128	139	150	171
					Alt.	53	62	90	98	111	120	128	139	150	171
40	1016.0	19.1	469.55	977.8	Std.	47	54	98	107	121	131	140	152	163	187
					Alt.	58	68	98	107	121	131	140	152	163	187
40	1016.0	20.6	505.66	974.8	Std.	50	59	106	116	131	141	151	164	176	201
					Alt.	63	73	106	116	131	141	151	164	176	201
40	1016.0	22.2	544.06	971.6	Std.	54	63	114	125	141	152	163	176	190	207
					Alt.	68	79	114	125	141	152	163	176	190	217
40	1016.0	23.8	582.33	968.4	Std.	58	68	122	134	151	163	175	189	204	207
					Alt.	73	85	122	134	151	163	175	189	204	233
40	1016.0	25.4	620.48	965.2	Std.	62	72	131	143	162	174	186	202	207	207
					Alt.	78	90	131	143	162	174	186	202	217	248
40	1016.0	27.0	658.50	962.0	Std.	66	77	139	152	172	185	198	207	207	207
					Alt.	83	96	139	152	172	185	198	214	231	250
40	1016.0	28.6	696.39	958.8	Std.	70	81	147	161	182	196	207	207	207	207
					Alt.	87	102	147	161	182	196	210	227	245	250
40	1016.0	30.2	734.16	955.6	Std.	74	86	155	170	192	207	207	207	207	207
					Alt.	92	107	155	170	192	207	222	240	250	250
40	1016.0	31.8	771.80	952.4	Std.	78	91	163	179	202	207	207	207	207	207
					Alt.	97	113	163	179	202	217	233	250	250	250
42	1067.0	8.7	227.05	1049.6	Std.	20	24	43	47	53	57	61	66	71	81
					Alt.	25	29	43	47	53	57	61	66	71	81
42	1067.0	9.5	247.74	1048.0	Std.	22	26	46	51	58	62	66	72	77	88
					Alt.	28	32	46	51	58	62	66	72	77	88

Table E-6C—Plain-end Line Pipe Dimensions, Weights per Unit Length, and Test Pressures for Sizes 6⁵/₈ through 80 (SI Units) (Continued)

(1)	(2)	(3)	(4)	(5)	(6)	(7)	(8)	(9)	(10)	(11)	(12)	(13)	(14)	(15)	
Size	Specified Outside Diameter <i>D</i> (mm)	Specified Wall Thickness <i>t</i> (mm)	Plain-end Weight per Unit Length <i>w_{pe}</i> (kg/m)	Calculated Inside Diameter ^a <i>d</i> (mm)	Minimum Test Pressure ^b (kPa × 100) ^c										
					Grade A	Grade B	Grade X42	Grade X46	Grade X52	Grade X56	Grade X60	Grade X65	Grade X70	Grade X80	
42	1067.0	10.3	268.40	1046.4	Std.	24	28	50	55	62	67	72	78	84	96
					Alt.	30	35	50	55	62	67	72	78	84	96
42	1067.0	11.1	289.03	1044.8	Std.	26	30	54	59	67	72	78	84	90	103
					Alt.	32	38	54	59	67	72	78	84	90	103
42	1067.0	11.9	309.62	1043.2	Std.	28	32	58	64	72	77	83	90	97	111
					Alt.	35	40	58	64	72	77	83	90	97	111
42	1067.0	12.7	330.19	1041.6	Std.	30	34	62	68	77	83	89	96	103	118
					Alt.	37	43	62	68	77	83	89	96	103	118
42	1067.0	14.3	371.22	1038.4	Std.	33	39	70	76	87	93	100	108	117	133
					Alt.	42	48	70	76	87	93	100	108	117	133
42	1067.0	15.9	412.13	1035.2	Std.	37	43	78	85	96	104	111	120	130	148
					Alt.	46	54	78	85	96	104	111	120	130	148
42	1067.0	17.5	452.91	1032.0	Std.	41	47	86	94	106	114	122	132	143	163
					Alt.	51	59	86	94	106	114	122	132	143	163
42	1067.0	19.1	493.57	1028.8	Std.	44	52	93	102	116	124	133	144	156	178
					Alt.	56	65	93	102	116	124	133	144	156	178
42	1067.0	20.6	531.57	1025.8	Std.	48	56	101	110	125	134	144	156	168	192
					Alt.	60	70	101	110	125	134	144	156	168	192
42	1067.0	22.2	571.98	1022.6	Std.	52	60	109	119	134	145	155	168	181	207
					Alt.	65	75	109	119	134	145	155	168	181	207
42	1067.0	23.8	612.26	1019.4	Std.	55	65	116	127	144	155	166	180	194	207
					Alt.	69	81	116	127	144	155	166	180	194	222
42	1067.0	25.4	652.42	1016.2	Std.	59	69	124	136	154	165	177	192	207	207
					Alt.	74	86	124	136	154	165	177	192	207	237
42	1067.0	27.0	692.45	1013.0	Std.	63	73	132	144	164	176	189	204	207	207
					Alt.	79	91	132	144	164	176	189	204	220	250
42	1067.0	28.6	732.36	1009.8	Std.	67	78	140	153	173	186	200	207	207	207
					Alt.	83	97	140	153	173	186	200	216	233	250
42	1067.0	30.2	772.14	1006.6	Std.	70	82	148	162	183	197	207	207	207	207
					Alt.	88	102	148	162	183	197	211	228	246	250
42	1067.0	31.8	811.79	1003.4	Std.	74	86	156	170	193	207	207	207	207	207
					Alt.	93	108	156	170	193	207	222	240	250	250
44	1118.0	8.7	237.99	1100.6	Std.	19	23	41	44	50	54	58	63	68	77
					Alt.	24	28	41	44	50	54	58	63	68	77
44	1118.0	9.5	259.69	1099.0	Std.	21	25	44	48	55	59	63	69	74	84
					Alt.	26	31	44	48	55	59	63	69	74	84
44	1118.0	10.3	281.35	1097.4	Std.	23	27	48	53	60	64	69	74	80	92
					Alt.	29	33	48	53	60	64	69	74	80	92
44	1118.0	11.1	302.99	1095.8	Std.	25	29	52	57	64	69	74	80	86	99
					Alt.	31	36	52	57	64	69	74	80	86	99
44	1118.0	11.9	324.59	1094.2	Std.	26	31	56	61	69	74	79	86	93	106
					Alt.	33	38	56	61	69	74	79	86	93	106
44	1118.0	12.7	346.16	1092.6	Std.	28	33	59	65	73	79	85	92	99	113
					Alt.	35	41	59	65	73	79	85	92	99	113
44	1118.0	14.3	389.21	1089.4	Std.	32	37	67	73	83	89	95	103	111	127
					Alt.	40	46	67	73	83	89	95	103	111	127
44	1118.0	15.9	432.13	1086.2	Std.	35	41	74	81	92	99	106	115	124	141
					Alt.	44	51	74	81	92	99	106	115	124	141
44	1118.0	17.5	474.92	1083.0	Std.	39	45	82	89	101	109	117	126	136	156
					Alt.	49	57	82	89	101	109	117	126	136	156

Table E-6C—Plain-end Line Pipe Dimensions, Weights per Unit Length, and Test Pressures for Sizes 6⁵/₈ through 80 (SI Units) (Continued)

(1) Size	(2) Specified Outside Diameter <i>D</i> (mm)	(3) Specified Wall Thickness <i>t</i> (mm)	(4) Plain-end Weight per Unit Length <i>w_{pe}</i> (kg/m)	(5) Calculated Inside Diameter ^a <i>d</i> (mm)		(6)	(7)	(8)	(9)	(10)	(11)	(12)	(13)	(14)	(15)
						Minimum Test Pressure ^b (kPa × 100) ^c									
						Grade A	Grade B	Grade X42	Grade X46	Grade X52	Grade X56	Grade X60	Grade X65	Grade X70	Grade X80
44	1118.0	19.1	517.59	1079.8	Std.	42	49	89	97	110	119	127	138	149	170
					Alt.	53	62	89	97	110	119	127	138	149	170
44	1118.0	20.6	557.47	1076.8	Std.	46	53	96	105	119	128	137	149	160	183
					Alt.	57	67	96	105	119	128	137	149	160	183
44	1118.0	22.2	599.90	1073.6	Std.	49	57	104	113	128	138	148	160	173	197
					Alt.	62	72	104	113	128	138	148	160	173	197
44	1118.0	23.8	642.19	1070.4	Std.	53	62	111	121	138	148	159	172	185	207
					Alt.	66	77	111	121	138	148	159	172	185	212
44	1118.0	25.4	684.37	1067.2	Std.	56	66	119	130	147	158	169	183	198	207
					Alt.	71	82	119	130	147	158	169	183	198	226
44	1118.0	27.0	726.41	1064.0	Std.	60	70	126	138	156	168	180	195	207	207
					Alt.	75	87	126	138	156	168	180	195	210	240
44	1118.0	28.6	768.33	1060.8	Std.	64	74	134	146	165	178	191	206	207	207
					Alt.	79	92	134	146	165	178	191	206	222	250
44	1118.0	30.2	810.12	1057.6	Std.	67	78	141	154	175	188	201	207	207	207
					Alt.	84	98	141	154	175	188	201	218	235	250
44	1118.0	31.8	851.79	1054.4	Std.	71	82	148	162	184	198	207	207	207	207
					Alt.	88	103	148	162	184	198	212	229	247	250
46	1168.0	8.7	248.72	1150.6	Std.	19	22	39	43	48	52	56	60	65	74
					Alt.	23	27	39	43	48	52	56	60	65	74
46	1168.0	9.5	271.40	1149.0	Std.	20	24	42	46	53	57	61	66	71	81
					Alt.	25	29	42	46	53	57	61	66	71	81
46	1168.0	10.3	294.05	1147.4	Std.	22	26	46	50	57	61	66	71	77	88
					Alt.	27	32	46	50	57	61	66	71	77	88
46	1168.0	11.1	316.67	1145.8	Std.	24	27	50	54	61	66	71	77	83	94
					Alt.	30	34	50	54	61	66	71	77	83	94
46	1168.0	11.9	339.26	1144.2	Std.	25	29	53	58	66	71	76	82	89	101
					Alt.	32	37	53	58	66	71	76	82	89	101
46	1168.0	12.7	361.82	1142.6	Std.	27	31	57	62	70	76	81	88	95	108
					Alt.	34	39	57	62	70	76	81	88	95	108
46	1168.0	14.3	406.84	1139.4	Std.	30	35	64	70	79	85	91	99	106	122
					Alt.	38	44	64	70	79	85	91	99	106	122
46	1168.0	15.9	451.73	1136.2	Std.	34	39	71	78	88	95	101	110	118	135
					Alt.	42	49	71	78	88	95	101	110	118	135
46	1168.0	17.5	496.50	1133.0	Std.	37	43	78	85	97	104	112	121	130	149
					Alt.	47	54	78	85	97	104	112	121	130	149
46	1168.0	19.1	541.14	1129.8	Std.	41	47	85	93	106	114	122	132	142	162
					Alt.	51	59	85	93	106	114	122	132	142	162
46	1168.0	20.6	582.87	1126.8	Std.	44	51	92	101	114	123	131	142	153	175
					Alt.	55	64	92	101	114	123	131	142	153	175
46	1168.0	22.2	627.27	1123.6	Std.	47	55	99	108	123	132	142	153	165	189
					Alt.	59	69	99	108	123	132	142	153	165	189
46	1168.0	23.8	671.54	1120.4	Std.	51	59	106	116	132	142	152	164	177	202
					Alt.	63	74	106	116	132	142	152	164	177	202
46	1168.0	25.4	715.68	1117.2	Std.	54	63	114	124	141	151	162	175	189	207
					Alt.	68	79	114	124	141	151	162	175	189	216
46	1168.0	27.0	759.70	1114.0	Std.	57	67	121	132	149	161	172	186	201	207
					Alt.	72	84	121	132	149	161	172	186	201	230
46	1168.0	28.6	803.59	1110.8	Std.	61	71	128	140	158	170	182	197	207	207
					Alt.	76	89	128	140	158	170	182	197	213	243

Table E-6C—Plain-end Line Pipe Dimensions, Weights per Unit Length, and Test Pressures for Sizes 6⁵/₈ through 80 (SI Units) (Continued)

(1)	(2)	(3)	(4)	(5)	(6)	(7)	(8)	(9)	(10)	(11)	(12)	(13)	(14)	(15)	
Size	Specified Outside Diameter <i>D</i> (mm)	Specified Wall Thickness <i>t</i> (mm)	Plain-end Weight per Unit Length <i>w_{pe}</i> (kg/m)	Calculated Inside Diameter ^a <i>d</i> (mm)	Minimum Test Pressure ^b (kPa × 100) ^c										
					Grade A	Grade B	Grade X42	Grade X46	Grade X52	Grade X56	Grade X60	Grade X65	Grade X70	Grade X80	
56	1422.0	27.0	928.82	1368.0	Std.	47	55	99	108	123	132	141	153	165	189
					Alt.	59	69	99	108	123	132	141	153	165	189
56	1422.0	28.6	982.73	1364.8	Std.	50	58	105	115	130	140	150	162	175	200
					Alt.	62	73	105	115	130	140	150	162	175	200
56	1422.0	30.2	1036.52	1361.6	Std.	53	61	111	121	137	148	158	171	185	207
					Alt.	66	77	111	121	137	148	158	171	185	211
56	1422.0	31.8	1090.18	1358.4	Std.	56	65	117	128	145	155	167	180	194	207
					Alt.	69	81	117	128	145	155	167	180	194	222
60	1524.0	9.5	354.80	1505.0	Std.	15	18	33	36	40	43	46	50	54	62
					Alt.	19	23	33	36	40	43	46	50	54	62
60	1524.0	10.3	384.48	1503.4	Std.	17	20	35	39	44	47	50	55	59	67
					Alt.	21	24	35	39	44	47	50	55	59	67
60	1524.0	11.1	414.12	1501.8	Std.	18	21	38	42	47	51	54	59	63	72
					Alt.	23	26	38	42	47	51	54	59	63	72
60	1524.0	11.9	443.73	1500.2	Std.	19	23	41	45	50	54	58	63	68	78
					Alt.	24	28	41	45	50	54	58	63	68	78
60	1524.0	12.7	473.31	1498.6	Std.	21	24	44	48	54	58	62	67	72	83
					Alt.	26	30	44	48	54	58	62	67	72	83
60	1524.0	14.3	532.38	1495.4	Std.	23	27	49	54	61	65	70	76	82	93
					Alt.	29	34	49	54	61	65	70	76	82	93
60	1524.0	15.9	591.32	1492.2	Std.	26	30	54	60	67	72	78	84	91	104
					Alt.	32	38	54	60	67	72	78	84	91	104
60	1524.0	17.5	650.13	1489.0	Std.	29	33	60	66	74	80	86	93	100	114
					Alt.	36	42	60	66	74	80	86	93	100	114
60	1524.0	19.1	708.82	1485.8	Std.	31	36	65	72	81	87	93	101	109	125
					Alt.	39	45	65	72	81	87	93	101	109	125
60	1524.0	20.6	763.72	1482.8	Std.	34	39	71	77	87	94	101	109	118	134
					Alt.	42	49	71	77	87	94	101	109	118	134
60	1524.0	22.2	822.16	1479.6	Std.	36	42	76	83	94	101	109	117	127	145
					Alt.	45	53	76	83	94	101	109	117	127	145
60	1524.0	23.8	880.48	1476.4	Std.	39	45	82	89	101	109	116	126	136	155
					Alt.	48	56	82	89	101	109	116	126	136	155
60	1524.0	25.4	938.67	1473.2	Std.	41	48	87	95	108	116	124	134	145	166
					Alt.	52	60	87	95	108	116	124	134	145	166
60	1524.0	27.0	996.73	1470.0	Std.	44	51	92	101	114	123	132	143	154	176
					Alt.	55	64	92	101	114	123	132	143	154	176
60	1524.0	28.6	1054.67	1466.8	Std.	47	54	98	107	121	130	140	151	163	186
					Alt.	58	68	98	107	121	130	140	151	163	186
60	1524.0	30.2	1112.48	1463.6	Std.	49	57	103	113	128	138	148	160	172	197
					Alt.	62	72	103	113	128	138	148	160	172	197
60	1524.0	31.8	1170.17	1460.4	Std.	52	60	109	119	135	145	155	168	181	207
					Alt.	65	75	109	119	135	145	155	168	181	207
64	1626.0	9.5	378.70	1607.0	Std.	15	17	30	33	38	41	44	47	51	58
					Alt.	18	21	30	33	38	41	44	47	51	58
64	1626.0	10.3	410.38	1605.4	Std.	16	18	33	36	41	44	47	51	55	63
					Alt.	20	23	33	36	41	44	47	51	55	63
64	1626.0	11.1	442.04	1603.8	Std.	17	20	36	39	44	47	51	55	59	68
					Alt.	21	25	36	39	44	47	51	55	59	68
64	1626.0	11.9	473.66	1602.2	Std.	18	21	38	42	47	51	55	59	64	73
					Alt.	23	26	38	42	47	51	55	59	64	73

Table E-6C—Plain-end Line Pipe Dimensions, Weights per Unit Length, and Test Pressures for Sizes 6⁵/₈ through 80 (SI Units) (Continued)

(1) Size	(2) Specified Outside Diameter <i>D</i> (mm)	(3) Specified Wall Thickness <i>t</i> (mm)	(4) Plain-end Weight per Unit Length <i>w_{pe}</i> (kg/m)	(5) Calculated Inside Diameter ^a <i>d</i> (mm)	(6) through (15) Minimum Test Pressure ^b (kPa × 100) ^c										
					Grade										
					A	B	X42	X46	X52	X56	X60	X65	X70	X80	
64	1626.0	12.7	505.26	1600.6	Std.	19	23	41	45	50	54	58	63	68	78
					Alt.	24	28	41	45	50	54	58	63	68	78
64	1626.0	14.3	568.35	1597.4	Std.	22	25	46	50	57	61	66	71	76	87
					Alt.	27	32	46	50	57	61	66	71	76	87
64	1626.0	15.9	631.31	1594.2	Std.	24	28	51	56	63	68	73	79	85	97
					Alt.	30	35	51	56	63	68	73	79	85	97
64	1626.0	17.5	694.15	1591.0	Std.	27	31	56	61	70	75	80	87	94	107
					Alt.	33	39	56	61	70	75	80	87	94	107
64	1626.0	19.1	756.86	1587.8	Std.	29	34	61	67	76	82	88	95	102	117
					Alt.	36	42	61	67	76	82	88	95	102	117
64	1626.0	20.6	815.54	1584.8	Std.	31	37	66	72	82	88	94	102	110	126
					Alt.	39	46	66	72	82	88	94	102	110	126
64	1626.0	22.2	878.00	1581.6	Std.	34	39	71	78	88	95	102	110	119	136
					Alt.	42	49	71	78	88	95	102	110	119	136
64	1626.0	23.8	940.34	1578.4	Std.	36	42	76	84	95	102	109	118	127	145
					Alt.	45	53	76	84	95	102	109	118	127	145
64	1626.0	25.4	1002.56	1575.2	Std.	39	45	82	89	101	109	116	126	136	155
					Alt.	49	56	82	89	101	109	116	126	136	155
64	1626.0	27.0	1064.65	1572.0	Std.	41	48	87	95	107	115	124	134	144	165
					Alt.	52	60	87	95	107	115	124	134	144	165
64	1626.0	28.6	1126.61	1568.8	Std.	44	51	92	100	114	122	131	142	153	175
					Alt.	55	64	92	100	114	122	131	142	153	175
64	1626.0	30.2	1188.44	1565.6	Std.	46	54	97	106	120	129	138	150	161	185
					Alt.	58	67	97	106	120	129	138	150	161	185
64	1626.0	31.8	1250.15	1562.4	Std.	49	57	102	112	126	136	146	158	170	194
					Alt.	61	71	102	112	126	136	146	158	170	194
68	1727.0	11.9	503.30	1703.2	Std.	17	20	36	39	45	48	51	56	60	68
					Alt.	21	25	36	39	45	48	51	56	60	68
68	1727.0	12.7	536.89	1701.6	Std.	18	21	38	42	48	51	55	59	64	73
					Alt.	23	27	38	42	48	51	55	59	64	73
68	1727.0	14.3	603.96	1698.4	Std.	21	24	43	47	54	58	62	67	72	82
					Alt.	26	30	43	47	54	58	62	67	72	82
68	1727.0	15.9	670.91	1695.2	Std.	23	27	48	53	59	64	69	74	80	91
					Alt.	29	33	48	53	59	64	69	74	80	91
68	1727.0	17.5	737.73	1692.0	Std.	25	29	53	58	65	70	76	82	88	101
					Alt.	31	37	53	58	65	70	76	82	88	101
68	1727.0	19.1	804.43	1688.8	Std.	27	32	58	63	71	77	82	89	96	110
					Alt.	34	40	58	63	71	77	82	89	96	110
68	1727.0	20.6	866.84	1685.8	Std.	30	34	62	68	77	83	89	96	104	119
					Alt.	37	43	62	68	77	83	89	96	104	119
68	1727.0	22.2	933.30	1682.6	Std.	32	37	67	73	83	89	96	104	112	128
					Alt.	40	46	67	73	83	89	96	104	112	128
68	1727.0	23.8	999.62	1679.4	Std.	34	40	72	79	89	96	103	111	120	137
					Alt.	43	50	72	79	89	96	103	111	120	137
68	1727.0	25.4	1065.82	1676.2	Std.	37	43	77	84	95	102	110	119	128	146
					Alt.	46	53	77	84	95	102	110	119	128	146
68	1727.0	27.0	1131.89	1673.0	Std.	39	45	82	89	101	109	117	126	136	155
					Alt.	49	57	82	89	101	109	117	126	136	155
68	1727.0	28.6	1197.84	1669.8	Std.	41	48	86	94	107	115	123	134	144	165
					Alt.	51	60	86	94	107	115	123	134	144	165

Table E-6C—Plain-end Line Pipe Dimensions, Weights per Unit Length, and Test Pressures for Sizes 6⁵/₈ through 80 (SI Units) (Continued)

(1)	(2)	(3)	(4)	(5)	(6)	(7)	(8)	(9)	(10)	(11)	(12)	(13)	(14)	(15)	
Size	Specified Outside Diameter <i>D</i> (mm)	Specified Wall Thickness <i>t</i> (mm)	Plain-end Weight per Unit Length <i>w_{pe}</i> (kg/m)	Calculated Inside Diameter ^a <i>d</i> (mm)	Minimum Test Pressure ^b (kPa × 100) ^c										
					Grade A	Grade B	Grade X42	Grade X46	Grade X52	Grade X56	Grade X60	Grade X65	Grade X70	Grade X80	
68	1727.0	30.2	1263.66	1666.6	Std.	43	51	91	100	113	121	130	141	152	174
					Alt.	54	63	91	100	113	121	130	141	152	174
68	1727.0	31.8	1329.36	1663.4	Std.	46	53	96	105	119	128	137	148	160	183
					Alt.	57	67	96	105	119	128	137	148	160	183
72	1829.0	12.7	568.83	1803.6	Std.	17	20	36	40	45	48	52	56	60	69
					Alt.	22	25	36	40	45	48	52	56	60	69
72	1829.0	14.3	639.93	1800.4	Std.	19	23	41	45	51	54	58	63	68	78
					Alt.	24	28	41	45	51	54	58	63	68	78
72	1829.0	15.9	710.91	1797.2	Std.	22	25	45	50	56	60	65	70	76	86
					Alt.	27	31	45	50	56	60	65	70	76	86
72	1829.0	17.5	781.75	1794.0	Std.	24	28	50	55	62	66	71	77	83	95
					Alt.	30	35	50	55	62	66	71	77	83	95
72	1829.0	19.1	852.47	1790.8	Std.	26	30	55	60	67	73	78	84	91	104
					Alt.	32	38	55	60	67	73	78	84	91	104
72	1829.0	20.6	918.66	1787.8	Std.	28	33	59	64	73	78	84	91	98	112
					Alt.	35	41	59	64	73	78	84	91	98	112
72	1829.0	22.2	989.14	1784.6	Std.	30	35	63	69	78	84	90	98	106	121
					Alt.	38	44	63	69	78	84	90	98	106	121
72	1829.0	23.8	1059.49	1781.4	Std.	32	38	68	74	84	90	97	105	113	129
					Alt.	40	47	68	74	84	90	97	105	113	129
72	1829.0	25.4	1129.71	1778.2	Std.	34	40	72	79	90	96	103	112	121	138
					Alt.	43	50	72	79	90	96	103	112	121	138
72	1829.0	27.0	1199.81	1775.0	Std.	37	43	77	84	95	103	110	119	128	147
					Alt.	46	53	77	84	95	103	110	119	128	147
72	1829.0	28.6	1269.78	1771.8	Std.	39	45	82	89	101	109	117	126	136	155
					Alt.	49	57	82	89	101	109	117	126	136	155
72	1829.0	30.2	1339.62	1768.6	Std.	41	48	86	94	107	115	123	133	144	164
					Alt.	51	60	86	94	107	115	123	133	144	164
72	1829.0	31.8	1409.34	1765.4	Std.	43	50	91	99	112	121	130	140	151	173
					Alt.	54	63	91	99	112	121	130	140	151	173
76	1930.0	12.7	600.46	1904.6	Std.	16	19	34	38	43	46	49	53	57	65
					Alt.	20	24	34	38	43	46	49	53	57	65
76	1930.0	14.3	675.55	1901.4	Std.	18	21	39	42	48	51	55	60	64	74
					Alt.	23	27	39	42	48	51	55	60	64	74
76	1930.0	15.9	750.51	1898.2	Std.	20	24	43	47	53	57	61	66	72	82
					Alt.	26	30	43	47	53	57	61	66	72	82
76	1930.0	17.5	825.34	1895.0	Std.	23	26	47	52	59	63	68	73	79	90
					Alt.	28	33	47	52	59	63	68	73	79	90
76	1930.0	19.1	900.05	1891.8	Std.	25	29	52	56	64	69	74	80	86	98
					Alt.	31	36	52	56	64	69	74	80	86	98
76	1930.0	20.6	969.97	1888.8	Std.	27	31	56	61	69	74	80	86	93	106
					Alt.	33	39	56	61	69	74	80	86	93	106
76	1930.0	22.2	1044.43	1885.6	Std.	29	33	60	66	74	80	86	93	100	114
					Alt.	36	42	60	66	74	80	86	93	100	114
76	1930.0	23.8	1118.76	1882.4	Std.	31	36	64	70	80	86	92	99	107	123
					Alt.	38	45	64	70	80	86	92	99	107	123
76	1930.0	25.4	1192.97	1879.2	Std.	33	38	69	75	85	91	98	106	114	131
					Alt.	41	48	69	75	85	91	98	106	114	131
76	1930.0	27.0	1267.06	1876.0	Std.	35	40	73	80	90	97	104	113	122	139
					Alt.	43	51	73	80	90	97	104	113	122	139

Table E-6C—Plain-end Line Pipe Dimensions, Weights per Unit Length, and Test Pressures for Sizes 6⁵/₈ through 80 (SI Units) (Continued)

(1) Size	(2) Specified Outside Diameter <i>D</i> (mm)	(3) Specified Wall Thickness <i>t</i> (mm)	(4) Plain-end Weight per Unit Length <i>w_{pe}</i> (kg/m)	(5) Calculated Inside Diameter ^a <i>d</i> (mm)	(6)–(15) Minimum Test Pressure ^b (kPa × 100) ^c										
					Grade										
					A	B	X42	X46	X52	X56	X60	X65	X70	X80	
76	1930.0	28.6	1341.01	1872.8	Std.	37	43	77	85	96	103	110	119	129	147
					Alt.	46	54	77	85	96	103	110	119	129	147
76	1930.0	30.2	1414.84	1869.6	Std.	39	45	82	89	101	109	117	126	136	155
					Alt.	49	57	82	89	101	109	117	126	136	155
76	1930.0	31.8	1488.55	1866.4	Std.	41	48	86	94	106	114	123	133	143	164
					Alt.	51	60	86	94	106	114	123	133	143	164
80	2032.0	14.3	711.52	2003.4	Std.	17	20	37	40	45	49	52	57	61	70
					Alt.	22	25	37	40	45	49	52	57	61	70
80	2032.0	15.9	790.50	2000.2	Std.	19	23	41	45	51	54	58	63	68	78
					Alt.	24	28	41	45	51	54	58	63	68	78
80	2032.0	17.5	869.36	1997.0	Std.	21	25	45	49	56	60	64	69	75	86
					Alt.	27	31	45	49	56	60	64	69	75	86
80	2032.0	19.1	948.09	1993.8	Std.	23	27	49	54	61	65	70	76	82	93
					Alt.	29	34	49	54	61	65	70	76	82	93
80	2032.0	20.6	1021.78	1990.8	Std.	25	29	53	58	66	70	76	82	88	101
					Alt.	31	37	53	58	66	70	76	82	88	101
80	2032.0	22.2	1100.27	1987.6	Std.	27	32	57	62	71	76	81	88	95	109
					Alt.	34	39	57	62	71	76	81	88	95	109
80	2032.0	23.8	1178.63	1984.4	Std.	29	34	61	67	76	81	87	94	102	116
					Alt.	36	42	61	67	76	81	87	94	102	116
80	2032.0	25.4	1256.86	1981.2	Std.	31	36	65	71	81	87	93	101	109	124
					Alt.	39	45	65	71	81	87	93	101	109	124
80	2032.0	27.0	1334.97	1978.0	Std.	33	38	69	76	86	92	99	107	116	132
					Alt.	41	48	69	76	86	92	99	107	116	132
80	2032.0	28.6	1412.95	1974.8	Std.	35	41	73	80	91	98	105	113	122	140
					Alt.	44	51	73	80	91	98	105	113	122	140
80	2032.0	30.2	1490.80	1971.6	Std.	37	43	78	85	96	103	111	120	129	148
					Alt.	46	54	78	85	96	103	111	120	129	148
80	2032.0	31.8	1568.53	1968.4	Std.	39	45	82	89	101	109	117	126	136	155
					Alt.	49	57	82	89	101	109	117	126	136	155

Note: See Table 6C for U.S. Customary unit values corresponding to the SI unit values given in this table.

^aThe calculated inside diameters are given here for information (see 7.2).

^bThe test pressures given in Tables E-6A, E-6B, and E-6C apply to Grades A25, A, B, X42, X46, X52, X56, X60, X65, X70, and X80 only. See 9.4.3 for pressures applicable to other grades.

^c100 kPa = 1 bar.

^dPipe that has this combination of specified outside diameter and specified wall thickness is special plain-end pipe; other combinations given in this table are regular plain-end pipe. Pipe that has a combination of specified outside diameter and specified wall thickness that is intermediate to the tabulated values is considered to be special plain-end pipe if the next lower tabulated value is for special plain-end pipe; other intermediate combinations are considered to be regular plain-end pipe. (See Table 10 for the applicable weight tolerances.)

APPENDIX F—SUPPLEMENTARY REQUIREMENTS (NORMATIVE)

When specified on the purchase order, the following supplementary requirements (SR) shall apply.

SR3 Color Identification

SR3.1 For Grades X46 and higher of pipe sizes 4¹/₂ and larger shall be identified by color in accordance with the color code given in SR3.3.

SR3.2 The manufacturer shall apply a 2 in. (50 mm) daub of paint of the appropriate color on the inside surface at one end of each length of pipe.

SR3.3 The grade identification colors are as follows:

Grade	Color
X46	Black
X52	Green
X56	Blue
X60	Red
X65	White
X70	Purple
X80	Yellow

SR5 Fracture Toughness Testing (Charpy V-notch) for Pipe of Size 4¹/₂ or Larger

SR5.1 Charpy V-notch tests shall be conducted in accordance with ASTM A 370, except as modified herein. Either or both toughness criteria (SR5A—Shear Area or SR5B—Absorbed Energy) may be specified under this supplementary requirement.

SR5.2 The following applies to all specified limits and observed values to be used in connection with this supplementary requirement.

For purposes of determining conformance with these supplementary requirements, an observed value shall be rounded to the nearest whole number in accordance with the rounding method of ASTM E 29. Further, limiting values as specified or calculated under this supplementary requirement shall be expressed as whole numbers rounded, if necessary.

SR5.3 Except for flattened specimens, the requirements of this supplementary requirement are limited to pipe sizes and wall thicknesses from which a ¹/₂ size specimen may be secured.

The specimen shall be oriented circumferentially from a location 90° from the weld with the axis of the notch oriented through the pipe wall thickness as shown in Figure F-3.

SR5.4 Except as limited by item c below, any of the following Charpy V-notch specimens are permissible by agreement between the purchaser and the manufacturer.

a. *Full-size specimens.* Full-size specimens (10 mm by 10 mm) with or without tapered ends may be used (see note below and Figure F-2).

b. *Subsize specimens.* The largest possible subsize specimen (see Table F-1) with or without tapered ends may be used. All dimensions other than specimen width are the same as the full-size specimen. Selecting subsize specimens for pipe whose size permits full-size specimens is also permissible by agreement between the purchaser and the manufacturer.

c. *Flattened specimens.* When because of combinations of diameter and wall thickness the use of ²/₃ size tapered end specimens is not practicable (see Table F-1), flattened specimens, ¹/₂ size conventional specimens, or ¹/₂ size tapered end specimens shall be used by agreement between the purchaser and the manufacturer. Flattened specimens may be flattened at room temperature in the same manner as transverse tensile strip specimens are prepared. Hot flattening, artificial aging, or heat treatment of flattened specimens is not permitted.

The flattened specimens shall have OD and ID surfaces machined no more than sufficient to make them parallel, or the surfaces shall be wire brushed or cleaned without machining. The specimen width shall essentially represent the full wall thickness of the pipe. All dimensions other than specimen width shall be the same as full-size specimens. The user is cautioned that results of flattened specimens and full-size or subsize specimens may not be correlated or directly compared with one another.

Note: "Tapered end specimens" are designated as "tubular impact specimens containing original OD surface" in ASTM A 370. This terminology is not used here because of possible confusion with the flattened specimens permitted in this SR; flattened specimens may also contain the original OD surface (but not curvature), since machining of flattened specimens is not required by this SR.

SR5.5 If any Charpy V-notch test result for a heat of pipe fails to conform to the applicable requirements of SR5A or SR5B, the manufacturer may elect to heat treat the heat of pipe in accordance with the requirements of 5.4, consider it to be a new heat, test it in accordance with all requirements of 6.2, 9.3, SR5, and SR6 that are applicable to the order item, and proceed in accordance with the applicable requirements of this specification. After one reprocessing heat treatment, any additional reprocessing heat treatment shall be subject to agreement with the purchaser.

For non-heat treated pipe, any reprocessing heat treatment shall be subject to agreement with the purchaser. For heat treated pipe, any reprocessing with a different type of heat treatment (see 5.4) shall be subject to agreement with the purchaser.

SR5A Shear Area

SR5A.1 Three transverse specimens shall be taken from one length of pipe from each heat supplied on the order.

SR5A.2 The specimens shall be tested at 50°F (10°C) or at a lower temperature as specified by the purchaser. The average shear value of the fracture appearance of the three specimens shall not be less than 60%, and the all-heat average for each order per diameter size and grade shall not be less than 80%.

SR5A.3 If the average of the three specimens from one heat does not meet the requirement of 60% shear, the manufacturer may elect to repeat the tests on specimens cut from two additional lengths of pipe from the same heat. If such specimens conform to the specified requirements, all the lengths in the heat shall be accepted except the length initially selected for test. If any of the retest specimens fail to pass this specified retest requirement, the manufacturer may elect to test specimens cut from the individual lengths remaining in the heat.

SR5A.4 The average shear value for a heat shall be the average of the original three specimens if the average is 60% or more; the combined average of the retest specimens, provided the average of each group of three specimens is 60% or more; or, in the event individual lengths are tested, the combined average of all groups of three specimens that meet 60%. The all-heat average value is the combined average of the average shear value for each of the heats supplied for the order item.

SR5A.5 If the all-heat average of the order does not meet the requirement of 80% shear, the manufacturer shall be responsible for replacement of such heats as may be necessary to bring the average shear area up to 80%.

SR5A.6 Alternatively, the manufacturer may elect to test two or more additional lengths from one or more of the heats. In determining the new heat average, the original test values may be discarded if the pipe length represented is rejected or the three or more individual values are averaged. In any case, the new test values shall be incorporated into the value for the heat.

SR5A.7 Specimens showing material defects or defective preparation, whether observed before or after breaking, may be discarded and replacements shall be considered as original specimens.

SR5A.8 Marking. Pipe tested in accordance with the shear area requirements of this supplementary requirement shall be marked to indicate the type of test, the test temperature, and if flattened specimens are used, the type of specimen. Temperatures below zero shall be preceded by the letter M.

Example at + 32°F:	SR5A-32F
Example of flattened specimen	
at - 40°C:	SR5AF-M40C

SR5B Absorbed Energy

SR5B.1 The fracture toughness of the pipe shall be determined using Charpy V-notch impact test specimens in accordance with ASTM A 370, as modified herein, and the requirements of SR5A.1, except that test frequency shall be as indicated in SR5B.2. The purchaser shall specify, in whole numbers, both the test temperature and the minimum average absorbed energy for full-size specimens.

Specimens used for shear area determination according to SR5A may be additionally used for the determination of absorbed energy.

SR5B.2 Three transverse specimens representing one test shall be taken from one length of pipe from each inspection lot of 100 lengths per heat produced. An inspection lot shall consist of pipe that is made to the same size and same specified wall thickness by the same process and under the same manufacturing conditions.

SR5B.3 For acceptance, the average absorbed energy of the three individual specimens from a length shall not be less than the full-size value specified by the purchaser. In addition, the lowest individual reading of the three specimens shall not be less than 75% of the specified value. When subsize specimens are used, the individual readings and the average of the three readings are divided by the ratio of the specimen thickness tested to the full-size specimen thickness and compared with the full-size acceptance criteria. When flattened specimens are used, each of the three individual impact energy readings shall be multiplied by 0.3937 (10), and divided by the actual measured specimen width, in inches (millimeters). These results, and the average of the three results, shall meet the specified absorbed energy acceptance criteria for full-size specimens.

SR5B.4 Specimens showing material defects or defective preparations, whether observed before or after breaking, may be discarded and replacements shall be considered original specimens.

In the event a set of test specimens fails to meet the acceptance criteria, the manufacturer may elect to replace the lot of material involved or alternatively to test two more lengths from the same lot. If both of the new tests meet the acceptance criteria, then all pipe in that lot with the exception of the original selected length shall be considered to meet the requirement. Failure of either of the two additional tests shall require testing of each length in the lot for acceptance.

SR5B.5 Pipe complying with the absorbed energy requirements of this supplementary requirement shall be marked to indicate the type of test, the specified [full-size] minimum average absorbed energy, the test temperature, and, if flattened specimens are used, the type of specimen. Temperatures below zero shall be preceded by the letter M, and absorbed energy specified in joules shall be followed by the letter J.

Example for 20 ft-lb at +32°F: SR5B-20-32F
 Example of flattened specimens for 20 ft-lb at -40°F: SR5BF-20-M40F
 Example of flattened specimens for both SR5A and SR5B for 27 joules at 0°C: SR5ABF-27J-0C

SR6 Drop-weight Tear Testing on Welded Pipe of Size 20 or Larger, Grade X52 or Higher

SR6.1 Fracture toughness of pipe sizes 20 and larger, Grade X52 and higher, shall be determined by the manufacturer using drop-weight tear tests in accordance with the following requirements in SR6.2 through SR6.8.

SR6.2 Two transverse specimens shall be taken from one length of pipe from each heat supplied on the order. The specimens shall be oriented circumferentially from a location 90° from the weld with the axis of the notch oriented through the pipe wall thickness as shown in Figure F-3. The specimens shall be tested at 50°F (10°C) or at a lower temperature as specified by the purchaser.

SR6.3 The test specimens, testing procedure, and rating of the specimens shall be in accordance with API RP 5L3. The type of notch (pressed or chevron) shall be selected by agreement between the manufacturer and the purchaser.

SR6.4 At least 80% of the heats shall exhibit a fracture appearance shear area of 40% or more for the specified test temperature (see note).

Note: Due to manufacturing difficulties encountered with thicker materials, pipe manufacturers may not be able to offer pipe in all grades that meet this requirement.

SR6.5 In the event the average value of the two specimens from the length selected to represent the heat is less than 40%, the manufacturer may elect to establish the heat average by testing two specimens from each of two or more additional lengths of pipe in the heat. In establishing the new heat average, the manufacturer may elect (a) to employ the combined average of the three tests or more; or (b) to discard the result of the first test, reject the pipe from which it was taken, and employ the combined average of the two or more additional tests. Alternatively, the manufacturer may elect to test all the pipe in the heat, in which case 80% or more of the lengths tested and applied to the order shall exhibit an average of 40% or more shear.

SR6.6 Specimens showing material defects or defective preparation, whether observed before or after breaking, may be discarded, and replacements shall be considered as original specimens.

SR6.7 The manufacturer shall be responsible for replacement of such heats as may be necessary to meet the above requirements.

SR6.8 Pipe tested in accordance with SR6 shall be marked to indicate the type of test, the type of notch, and the testing temperature. Temperatures below zero shall be preceded by the letter M.

Example for chevron notch at 32°F: SR6C-32F
 Example for pressed notch at -10°C: SR6P-M10C

SR7 Through-the-Flowline (TFL) Pipe

SR7.1 GENERAL

TFL pipe shall comply with all requirements of this specification and the additional requirements specified in SR7.2 through SR7.6.

SR7.2 DIMENSION AND GRADES

TFL pipe shall be seamless or longitudinal seam pipe in the outside diameters, wall thicknesses, and grades listed in Table F-2.

SR7.3 LENGTH

Unless otherwise specified, TFL pipe shall be furnished only in double random lengths with no jointers (girth welds).

SR7.4 DRIFT TESTS

Each length of TFL pipe shall be tested throughout its entire length with a cylindrical drift mandrel conforming to the requirements listed below. The leading edge of the drift mandrel shall be rounded to permit easy entry into the pipe. The drift mandrel shall pass freely through the pipe with a reasonable exerted force equivalent to the weight of the mandrel being used for the test. Pipe shall not be rejected until it has been drift tested when it is free of all foreign matter and properly supported to prevent sagging.

Size	Drift Mandrel Size			
	Length		Diam., min.	
	in.	mm	in.	mm
< 3 1/2	42	1066	$d - 3/32$	$d - 2.4$
≥ 3 1/2	42	1066	$d - 1/8$	$d - 3.2$

SR7.5 HYDROSTATIC TESTS

TFL pipe shall be hydrostatically tested in accordance with the requirements of 9.4, except that the minimum test pressures shall be as shown in Table F-2. These test pressures in Table F-2 represent the lesser of 10,000 psi (68 900 kPa) and

the pressure calculated with the equation given in 9.4.3, using a fiber stress (S) equal to 80% of the specified minimum yield strength.

SR7.6 MARKING

TFL pipe manufactured in accordance with SR7 shall be marked with the letters TFL in addition to the marking required in Section 10 or Appendix I.

SR15 Test Certificates and Traceability for Line Pipe

SR15.1 The manufacturer shall provide the following data, as applicable, for each order item for which this supplementary requirement is specified on the purchase order. The manufacturer's certificate of compliance shall state the API specification and date of revision to which pipe was manufactured. A Material Test Report, Certificate of Compliance, or similar document printed from or used in electronic form from an electronic data interchange (EDI) transmission shall be regarded as having the same validity as a counterpart printed in the manufacturer's facility. The content of the EDI transmitted document must meet the requirements of this specification and conform to any existing EDI agreement between the purchaser and the manufacturer.

- a. Specified outside diameter, specified wall thickness, grade, process of manufacture, and type of heat treatment.
- b. Chemical analyses (heat, product, control, and recheck) showing the weight percent of all elements whose limits or reporting requirements are set in this specification; for PSL 2 pipe, carbon equivalent and applicable maximum allowable value. If order is for by-agreement "high carbon equivalent pipe," that designation shall be included.
- c. Test data for all tensile tests required by this specification, including yield strength, ultimate tensile strength, and elongation. The type, size, and orientation of specimens shall be shown.
- d. Fracture toughness test results (including test type and criteria and the size, location, and orientation of the specimen) where such testing is required.
- e. Minimum hydrostatic test pressure and duration.
- f. For welded pipe for which nondestructive inspection of the weld seam is required by this specification, the method of nondestructive inspection employed (radiological, ultrasonic, electromagnetic, and/or magnetic particle), and the type and size of all penetrameters and reference standards used.
- g. For seamless pipe for which nondestructive inspection is required, the method of inspection employed (ultrasonic, electromagnetic, or magnetic particle) and the type and size of the reference indicators used.
- h. For electric welded pipe and laser welded pipe, the minimum temperature for heat treatment of the weld seam. Where

such heat treatment is not performed, the words "No Seam Heat Treatment" shall be stated on the certificate.

i. Results of any supplemental testing required by the purchaser.

SR15.2 The manufacturer shall establish and follow procedures for maintaining heat and lot identity of all pipe covered by this supplementary requirement. The procedures shall provide means for tracing any length of pipe or coupling to the proper heat and lot and to all applicable chemical and mechanical test results.

SR17 Nondestructive Inspection of Welds in Electric Welded Pipe and Laser Welded Pipe

SR17.1 SUPPLEMENTARY NONDESTRUCTIVE INSPECTION

The weld in electric welded pipe shall be inspected full length for surface and subsurface defects by either ultrasonic or electromagnetic methods. The weld in laser-welded pipe shall be inspected full length for surface and subsurface defects by ultrasonic methods. The location of the equipment in the mill shall be at the discretion of the manufacturer. However, the nondestructive inspection shall take place after all heat treating, hydrostatic testing, expansion, and rotary straightening operations, if performed, but may take place before cropping, beveling, and sizing of pipe.

SR17.2 EQUIPMENT AND REFERENCE STANDARDS

The ultrasonic or electromagnetic inspection equipment requirements are given in 9.7.4.1, and the reference standards are described in 9.7.4.2. Details of the specific techniques (such as method, reference indicators, transducer properties, and sensitivity) shall be agreed upon between the purchaser and the manufacturer for the implementation of this supplementary requirement.

SR17.3 ACCEPTANCE LIMITS AND EMI INSPECTIONS

Table 21 gives the height of acceptance limit signals in percent of height of signals produced by reference standards. An imperfection that produced a signal greater than the acceptance limit signal given in Table 21 shall be classified as a defect.

SR17.4 DISPOSITION

Disposition of defects shall be in accordance with 9.9, item a, c, or d. Repair by welding is not permitted. If a defect is removed by grinding, the ground area shall be reinspected by the same method originally used.

SR17.5 MARKING

Pipe nondestructively inspected in accordance with this supplementary requirement shall be marked SR17.

SR18 Carbon Equivalent

SR18.1 For pipe grades up to Grade X70 inclusive, the carbon equivalent, CE, calculated using product analysis and the following equation shall not exceed 0.43%:

$$CE = C + \frac{Mn}{6} + \frac{Cr + Mo + V}{5} + \frac{Ni + Cu}{15}$$

SR18.2 The elements analyzed for product analysis shall include all elements contained in the carbon equivalent equation.

SR19 Additional Fracture Toughness Requirements (Transverse Charpy V-notch) for PSL 2 Pipe

SR19.1 Except as allowed by SR19.2, fracture toughness testing shall be performed in accordance with the requirements of 9.3.5.1 and 9.3.5.2, with a test temperature of 32°F (0°C) or a lower temperature as specified on the purchase order. The required minimum all-heat average full-size absorbed energy value shall be the greater of

- a. 30 ft-lb (40 J) for grades below Grade X80, 60 ft-lb (80 J) for Grade X80 pipe; and
- b. The value obtained from the following equation, using a stress factor (*F*) of 0.72 or a higher value if specified on the purchase order, and rounding the calculated value to the nearest foot-pound (joule):

U.S. Customary Unit Equation SI Unit Equation

$$CV = 0.0345(F\sigma_y)^2 \left(\frac{D}{2}\right)^{\frac{1}{2}} \quad CV = 0.000512(F\sigma_y)^2 \left(\frac{D}{2}\right)^{\frac{1}{2}}$$

where

- CV* = minimum all-heat average full-size Charpy V-notch absorbed energy requirement, ft-lb (J),
- F* = stress factor,
- σ_y = specified minimum yield strength, ksi (MPa),
- D* = specified outside diameter, in. (mm).

Notes:

1. See Table F-3 for the required minimum all heat-average absorbed energy values for pipe having a standard size and grade, and a stress factor of 0.72.
2. The above equation is one of a number of such relationships derived from full-scale burst test data for a limited number of sizes and grades (see ASME B31.8). It is also judged to be conservative for initiation conditions in pipelines.

SR19.2 Pipe tested at a lower temperature than is required in SR19.1 shall be acceptable if it meets the required absorbed energy values.

SR19.3 Pipe tested in accordance with SR19 shall be marked to indicate the specified (full-size) minimum all-heat average absorbed energy value and the specified test temperature. Temperatures below zero shall be preceded by the letter M, and the absorbed energy specified in joules shall be followed by the letter J.

- Example for 30 ft-lb at + 32°F: SR19-30-32F
- Example for 70 J at – 5°C: SR19-70J-M5C

04

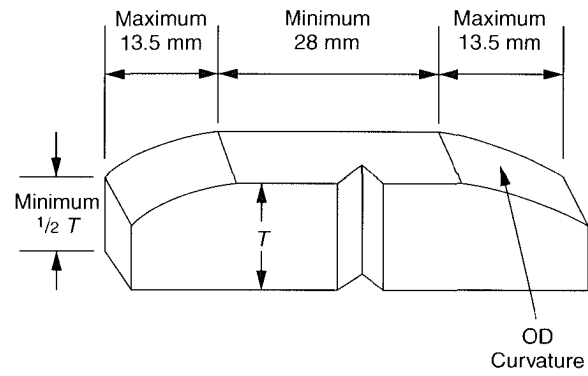

Figure F-1—Impact Test Specimen Tapered End Allowance

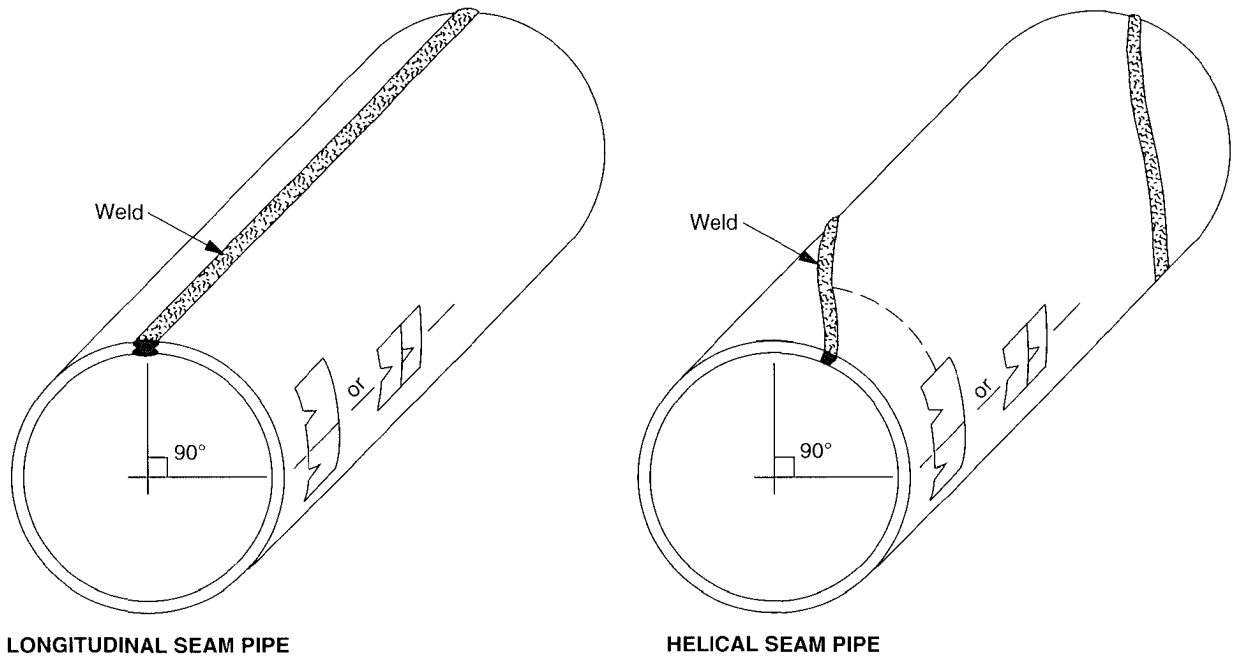

Figure F-2—Charpy V-notch and Drop-weight Tear Test Specimen Locations

Table F-1—Minimum Wall Thickness to Obtain Transverse Charpy V-notch Test Specimens^a

Size	Specified Wall Thickness, Minimum, in. (mm)		
	Full Size Specimen	² / ₃ Size Specimen	¹ / ₂ Size Specimen
≥ 4 ¹ / ₂ and < 5 ⁹ / ₁₆	0.495 (12.6)	0.429 (10.9)	0.397 (10.1)
≥ 5 ⁹ / ₁₆ and < 6 ⁵ / ₈	0.469 (11.9)	0.371 (9.4)	0.338 (8.6)
≥ 6 ⁵ / ₈ and < 8 ⁵ / ₈	0.460 (11.7)	0.334 (8.5)	0.301 (7.6)
≥ 8 ⁵ / ₈ and < 10 ³ / ₄	0.450 (11.4)	0.318 (8.1)	0.257 (6.5)
≥ 10 ³ / ₄ and < 12 ³ / ₄	0.443 (11.3)	0.311 (7.9)	0.246 (6.2)
≥ 12 ³ / ₄ and < 14	0.438 (11.1)	0.307 (7.638)	0.241 (6.1)
≥ 14 and < 16	0.436 (11.1)	0.305 (7.7)	0.239 (6.1)
≥ 16	0.434 (11.0)	0.304 (7.7)	0.237 (6.0)

^aThis table provides a description of the acceptable specimens and the relationship between pipe dimensions and acceptable specimens. The size limits shown are based upon the use of tapered end transverse specimens (see Figure F-2). These specimen dimension limits include machining tolerances.

Table F-2—Dimensions, Weights per Unit Length, and Test Pressures for TFL Pipe

(1) Size	(2) Specified Outside Diameter <i>D</i>		(3) Grade	(4) Specified Wall Thickness <i>t</i>		(5) Calculated Plain-end Weight per Unit Length <i>w_{pe}</i>		(6) Calculated Inside Diameter ^a <i>d</i>		(7) Minimum Hydrostatic Test Pressure	
	in.	mm.		in.	mm	lb/ft	kg/m	in.	mm	psi	100 kPa ^b
	2 ³ / ₈	2.375		60.3	X 56	0.188	4.8	4.40	6.57	1.999	50.7
2 ⁷ / ₈	2.875	73.0	X 56	0.438	11.1	11.41	16.94	1.999	50.8	10000	689
2 ⁷ / ₈	2.875	73.0	X 56	0.216	5.5	6.14	9.16	2.443	62.0	6730	465
3 ¹ / ₂	3.500	88.9	X 56	0.530	13.5	16.83	25.10	2.440	61.9	10000	689
4	4.000	101.6	X 60	0.750	19.1	26.06	38.86	2.500	63.4	10000	689
4	4.000	101.6	X 42	0.500	12.7	18.71	27.84	3.000	76.2	8400	579
4	4.000	101.6	X 60	0.500	12.7	18.71	27.84	3.000	76.2	10000	689
4	4.000	101.6	X 70	0.250	6.4	10.02	15.02	3.500	88.8	7000	486
4 ¹ / ₂	4.500	114.3	X 52	0.750	19.1	30.07	44.84	3.000	76.1	10000	689
4 ¹ / ₂	4.500	114.3	X 70	0.281	7.1	12.67	18.77	3.938	100.1	6990	480

^aThe calculated inside diameters are given here for information.

^b100 kPa = 1 bar.

Table F-3—Minimum All-heat Average Absorbed Energy Requirements for Stress Factor *f* of 0.72

(1)	(2)		(3)		(4)		(5)		(6)		(7)		(8)		(9)		(10)		
Size	Minimum All-heat Average Absorbed Energy, ft-lb (J)																		
	Grade																		
	B		X42		X46		X52		X56		X60		X65		X70		X80		
ft-lb	J	ft-lb	J	ft-lb	J	ft-lb	J	ft-lb	J	ft-lb	J	ft-lb	J	ft-lb	J	ft-lb	J	ft-lb	J
4 ¹ / ₂	30	40	30	40	30	40	30	40	30	40	30	40	30	40	30	40	60	80	
5 ⁹ / ₁₆	30	40	30	40	30	40	30	40	30	40	30	40	30	40	30	40	60	80	
6 ⁵ / ₈	30	40	30	40	30	40	30	40	30	40	30	40	30	40	30	40	60	80	
8 ⁵ / ₈	30	40	30	40	30	40	30	40	30	40	30	40	30	40	30	40	60	80	
10 ³ / ₄	30	40	30	40	30	40	30	40	30	40	30	40	30	40	30	40	60	80	
12 ³ / ₄	30	40	30	40	30	40	30	40	30	40	30	40	30	40	31	42	60	80	
14	30	40	30	40	30	40	30	40	30	40	30	40	30	40	33	44	60	80	
16	30	40	30	40	30	40	30	40	30	40	30	40	31	42	35	47	60	80	
18	30	40	30	40	30	40	30	40	30	40	30	40	33	45	37	50	60	80	
20	30	40	30	40	30	40	30	40	30	40	31	42	35	47	39	53	60	80	
22	30	40	30	40	30	40	30	40	30	40	32	44	37	50	41	56	60	80	
24	30	40	30	40	30	40	30	40	31	41	34	46	38	52	43	58	60	80	
26	30	40	30	40	30	40	30	40	32	43	35	48	40	54	45	60	60	80	
28	30	40	30	40	30	40	30	40	33	45	37	50	41	56	46	63	60	80	
30	30	40	30	40	30	40	31	42	34	46	38	51	43	58	48	65	60	80	
32	30	40	30	40	30	40	32	43	35	48	39	53	44	60	49	67	60	82	
34	30	40	30	40	30	40	33	44	36	49	40	55	46	62	51	69	62	84	
36	30	40	30	40	30	40	34	45	37	51	42	56	47	63	52	71	64	87	
38	30	40	30	40	30	40	34	47	39	52	43	58	48	65	54	73	66	89	
40	30	40	30	40	30	40	35	48	40	53	44	59	49	67	55	75	67	91	
42	30	40	30	40	30	41	36	49	40	55	45	61	51	69	57	77	69	94	
44	30	40	30	40	31	42	37	50	41	56	46	62	52	70	58	79	71	96	
46	30	40	30	40	32	43	38	51	42	57	47	64	53	72	59	80	72	98	
48	30	40	30	40	32	44	39	53	43	59	48	65	54	73	60	82	74	100	
52	30	40	30	40	34	45	40	55	45	61	50	68	56	76	63	85	77	104	

Table F-3 (Continued)—Minimum All-heat Average Absorbed Energy Requirements for Stress Factor f of 0.72

(1)	(2)		(3)		(4)		(5)		(6)		(7)		(8)		(9)		(10)	
Minimum All-heat Average Absorbed Energy, ft-lb (J)																		
Grade																		
Size	B		X42		X46		X52		X56		X60		X65		X70		X80	
	ft-lb	J	ft-lb	J	ft-lb	J	ft-lb	J	ft-lb	J	ft-lb	J	ft-lb	J	ft-lb	J	ft-lb	J
56	30	40	30	41	35	47	42	57	47	63	52	70	58	79	65	89	80	108
60	30	40	31	43	36	49	43	59	48	65	54	73	60	82	68	92	83	112
64	30	40	32	44	37	50	45	61	50	68	55	75	62	85	70	95	85	116
68	30	40	33	45	38	52	46	63	52	70	57	77	64	87	72	98	88	119
72	30	40	34	47	39	53	47	64	53	72	59	80	66	90	74	100	90	123
76	30	40	35	48	41	55	49	66	54	74	60	82	68	92	76	103	93	126
80	30	40	36	49	42	56	50	68	56	76	62	84	70	95	78	106	95	129

APPENDIX G—GUIDED-BEND TEST JIG DIMENSIONS (NORMATIVE)

Table G-1 contains guided-bend test jig dimensions discussed in 9.10.3.

104

Table G-1—Guided-bend Test Jig Dimensions

(1)	(2)		(3)		(4)		(5)		(6)		(7)		(8)		(9)		(10)		(11)												
																					Specified Wall Thickness <i>t</i>	Dimension A									
																						Grade									
																						A		B & X42		X46		X52		X56	
in.	mm	in.	mm	in.	mm	in.	mm	in.	mm	in.	mm	in.	mm	in.	mm	in.	mm	in.	mm												
12 ³ / ₄	0.172	4.4	1.0	25.4	1.4	35.6	1.4	35.6	1.6	40.6	1.6	40.6	1.6	40.6	1.9	48.3	1.9	48.3	2.2	55.9											
12 ³ / ₄	0.188	4.8	1.2	30.5	1.4	35.6	1.6	40.6	1.6	40.6	1.9	48.3	1.9	48.3	2.2	55.9	2.2	55.9	2.6	66.0											
12 ³ / ₄	0.203	5.2	—	—	1.6	40.6	1.6	40.6	48.3	48.3	1.9	55.9	2.2	55.9	2.2	55.9	2.2	55.9	2.6	66.0											
12 ³ / ₄	0.219	5.6	1.4	35.6	1.6	40.6	1.9	48.3	1.9	48.3	2.2	55.9	2.2	55.9	2.6	66.0	2.6	66.0	3.1	78.7											
12 ³ / ₄	0.250	6.4	1.6	40.6	2.2	55.9	2.2	55.9	2.2	55.9	2.6	66.0	2.6	66.0	3.1	78.7	3.1	78.7	3.7	94.0											
12 ³ / ₄	0.281	7.1	1.9	48.3	2.2	55.9	2.6	66.0	2.6	66.0	3.1	78.7	3.1	78.7	3.7	94.0	3.7	94.0	4.4	111.8											
12 ³ / ₄	0.312	7.9	2.2	55.9	2.6	66.0	2.6	66.0	3.1	78.7	3.1	78.7	3.7	94.0	3.7	94.0	3.7	94.0	5.2	132.1											
12 ³ / ₄	0.330	8.4	2.2	55.9	3.1	78.7	3.1	78.7	3.1	78.7	3.7	94.0	3.7	94.0	4.4	111.8	4.4	111.8	5.2	132.1											
12 ³ / ₄	0.344	8.7	2.2	55.9	3.1	78.7	3.1	78.7	3.7	94.0	3.7	94.0	4.4	111.8	4.4	111.8	5.2	132.1	5.2	132.1											
12 ³ / ₄	0.375	9.5	2.6	66.0	3.1	78.7	3.7	94.0	3.7	94.0	4.4	111.8	4.4	111.8	5.2	132.1	6.2	157.5	6.2	157.5											
12 ³ / ₄	0.406	10.3	—	—	3.7	94.0	3.7	94.0	111.8	4.4	4.4	111.8	5.2	132.1	6.2	157.5	6.2	157.5	7.4	188.0											
12 ³ / ₄	0.438	11.1	3.1	78.7	4.4	111.8	4.4	111.8	5.2	132.1	5.2	132.1	6.2	157.5	6.2	157.5	6.2	157.5	8.8	223.5											
12 ³ / ₄	0.500	12.7	—	—	5.2	132.1	5.2	132.1	6.2	157.5	6.2	157.5	7.4	188.0	7.4	188.0	8.8	223.5	10.5	266.7											
12 ³ / ₄	0.562	14.3	4.4	111.8	6.2	157.5	6.2	157.5	7.4	188.0	7.4	188.0	8.8	223.5	8.8	223.5	10.5	266.7	12.6	320.0											
12 ³ / ₄	0.625	15.9	5.2	132.1	7.4	188.0	7.4	188.0	8.8	223.5	10.5	266.7	10.5	266.7	12.6	320.0	12.6	320.0	18.1	459.7											
12 ³ / ₄	0.688	17.5	6.2	157.5	8.8	223.5	8.8	223.5	10.5	266.7	12.6	320.0	12.6	320.0	15.1	383.5	18.1	459.7	26.0	660.4											
12 ³ / ₄	0.750	19.1	7.4	188.0	10.5	266.7	10.5	266.7	12.6	320.0	15.1	383.5	15.1	383.5	18.1	459.7	21.7	551.2	31.2	792.5											
12 ³ / ₄	0.812	20.6	8.8	223.5	12.6	320.0	12.6	320.0	15.1	383.5	18.1	459.7	21.7	551.2	21.7	551.2	26.0	660.4	31.2	792.5											
12 ³ / ₄	0.875	22.2	10.5	266.7	15.1	383.5	18.1	459.7	18.1	459.7	21.7	551.2	26.0	660.4	31.2	792.5	31.2	792.5	31.2	792.5											
14	0.188	4.8	1.2	30.5	1.4	35.6	1.6	40.6	1.6	40.6	1.6	40.6	1.9	48.3	1.9	48.3	2.2	55.9	2.6	66.0											
14	0.203	5.2	1.2	30.5	1.6	40.6	—	—	—	—	—	—	—	—	—	—	—	—	2.6	66.0											
14	0.210	5.3	—	—	1.6	40.6	1.6	40.6	1.9	48.3	1.9	48.3	2.2	55.9	2.2	55.9	2.2	55.9	2.6	66.0											
14	0.219	5.6	—	—	1.6	40.6	1.9	48.3	1.9	48.3	2.2	55.9	2.2	55.9	2.2	55.9	2.6	66.0	3.1	78.7											
14	0.250	6.4	1.6	40.6	1.9	48.3	2.2	55.9	2.2	55.9	2.6	66.0	2.6	66.0	2.6	66.0	3.1	78.7	3.7	94.0											
14	0.281	7.1	1.9	48.3	2.2	55.9	2.6	66.0	2.6	66.0	2.6	66.0	3.1	78.7	3.1	78.7	3.1	78.7	4.4	111.8											
14	0.312	7.9	1.9	48.3	2.6	66.0	2.6	66.0	3.1	78.7	3.1	78.7	3.7	94.0	3.7	94.0	3.7	94.0	4.4	111.8											
14	0.344	8.7	2.2	55.9	3.1	78.7	3.1	78.7	3.1	78.7	3.7	94.0	3.7	94.0	3.7	94.0	4.4	111.8	5.2	132.1											
14	0.375	9.5	2.6	66.0	3.1	78.7	3.7	94.0	3.7	94.0	4.4	111.8	4.4	111.8	4.4	111.8	5.2	132.1	6.2	157.5											
14	0.406	10.3	—	—	3.7	94.0	3.7	94.0	4.4	111.8	4.4	111.8	5.2	132.1	5.2	132.1	5.2	132.1	7.4	188.0											
14	0.438	11.1	3.1	78.7	3.7	94.0	4.4	111.8	4.4	111.8	5.2	132.1	5.2	132.1	5.2	132.1	6.2	157.5	7.4	188.0											
14	0.469	11.9	—	—	4.4	111.8	4.4	111.8	5.2	132.1	5.2	132.1	6.2	157.5	6.2	157.5	7.4	188.0	8.8	223.5											
14	0.500	12.7	3.7	94.0	5.2	132.1	5.2	132.1	5.2	132.1	6.2	157.5	6.2	157.5	7.4	188.0	7.4	188.0	10.5	266.7											
14	0.562	14.3	4.4	111.8	6.2	157.5	6.2	157.5	6.2	157.5	7.4	188.0	8.8	223.5	8.8	223.5	8.8	223.5	12.6	320.0											
14	0.625	15.9	5.2	132.1	7.4	188.0	7.4	188.0	8.8	223.5	8.8	223.5	10.5	266.7	10.5	266.7	12.6	320.0	15.1	383.5											
14	0.688	17.5	6.2	157.5	8.8	223.5	8.8	223.5	10.5	266.7	10.5	266.7	12.6	320.0	12.6	320.0	15.1	383.5	18.1	459.7											
14	0.750	19.1	6.2	157.5	8.8	223.5	10.5	266.7	10.5	266.7	12.6	320.0	15.1	383.5	15.1	383.5	18.1	459.7	26.0	660.4											
14	0.812	20.6	7.4	188.0	10.5	266.7	—	—	—	—	—	—	—	—	—	—	—	—	—	—											
14	0.875	22.2	8.8	223.5	12.6	320.0	15.1	383.5	15.1	383.5	18.1	459.7	21.7	551.2	21.7	551.2	31.2	792.5	31.2	792.5											
14	0.938	23.8	10.5	266.7	15.1	383.5	18.1	459.7	21.7	551.2	21.7	551.2	26.0	660.4	31.2	792.5	31.2	792.5	31.2	792.5											
16	0.188	4.8	1.2	30.5	1.4	35.6	1.6	40.6	1.6	40.6	1.6	40.6	1.9	48.3	1.9	48.3	2.2	55.9	2.6	66.0											
16	0.203	5.2	1.2	30.5	1.6	40.6	1.6	40.6	1.6	40.6	1.9	48.3	1.9	48.3	1.9	48.3	2.2	55.9	2.6	66.0											
16	0.219	5.6	1.4	35.6	1.6	40.6	1.9	48.3	1.9	48.3	2.2	55.9	2.2	55.9	2.6	66.0	2.6	66.0	3.1	78.7											
16	0.250	6.4	1.6	40.6	1.9	48.3	2.2	55.9	2.2	55.9	2.2	55.9	2.6	66.0	2.6	66.0	2.6	66.0	3.1	78.7											
16	0.281	7.1	1.6	40.6	2.2	55.9	2.2	55.9	2.6	66.0	2.6	66.0	3.1	78.7	3.1	78.7	3.1	78.7	3.7	94.0											
16	0.312	7.9	1.9	48.3	2.6	66.0	2.6	66.0	3.1	78.7	3.1	78.7	3.1	78.7	3.1	78.7	3.7	94.0	4.4	111.8											
16	0.344	8.7	2.2	55.9	2.6	66.0	3.1	78.7	3.1	78.7	3.7	94.0	3.7	94.0	3.7	94.0	4.4	111.8	5.2	132.1											

Table G-1—Guided-bend Test Jig Dimensions (Continued)

(1) Size	(2) Specified Wall Thickness <i>t</i> in. mm		(3)–(11) Dimension A Grade																	
			(4) A		(5) B & X42		(6) X46		(7) X52		(8) X56		(9) X60		(10) X65		(11) X70		(12) X80	
			in.	mm	in.	mm	in.	mm	in.	mm	in.	mm	in.	mm	in.	mm	in.	mm	in.	mm
16	0.375	9.5	2.6	66.0	3.1	78.7	3.1	78.7	3.7	94.0	3.7	94.0	4.4	111.8	4.4	111.8	4.4	111.8	6.2	157.5
16	0.406	10.3	—	—	3.7	94.0	3.7	94.0	3.7	94.0	4.4	111.8	4.4	111.8	5.2	132.1	5.2	132.1	6.2	157.5
16	0.438	11.1	3.1	78.7	3.7	94.0	4.4	111.8	4.4	111.8	5.2	132.1	5.2	132.1	5.2	132.1	6.2	157.5	7.4	188.0
16	0.469	11.9	—	—	4.4	111.8	4.4	111.8	5.2	132.1	5.2	132.1	5.2	132.1	6.2	157.5	6.2	157.5	7.4	188.0
16	0.500	12.7	3.7	94.0	4.4	111.8	5.2	132.1	5.2	132.1	6.2	157.5	6.2	157.5	6.2	157.5	7.4	188.0	8.8	223.5
16	0.562	14.3	4.4	111.8	5.2	132.1	6.2	157.5	6.2	157.5	7.4	188.0	7.4	188.0	7.4	188.0	8.8	223.5	10.5	266.7
16	0.625	15.9	4.4	111.8	6.2	157.5	6.2	157.5	7.4	188.0	8.8	223.5	8.8	223.5	8.8	223.5	10.5	266.7	12.6	320.0
16	0.688	17.5	5.2	132.1	7.4	188.0	7.4	188.0	8.8	223.5	10.5	266.7	10.5	266.7	10.5	266.7	12.6	320.0	15.1	383.5
16	0.750	19.1	6.2	157.5	8.8	223.5	8.8	223.5	10.5	266.7	12.6	320.0	12.6	320.0	12.6	320.0	15.1	383.5	21.7	551.2
16	0.812	20.6	7.4	188.0	10.5	266.7	10.5	266.7	12.6	320.0	15.1	383.5	15.1	383.5	18.1	459.7	18.1	459.7	26.0	660.4
16	0.875	22.2	7.4	188.0	10.5	266.7	12.6	320.0	12.6	320.0	15.1	383.5	18.1	459.7	18.1	459.7	21.7	551.2	31.2	792.5
16	0.938	23.8	8.8	223.5	12.6	320.0	15.1	383.5	15.1	383.5	18.1	459.7	21.7	551.2	21.7	551.2	26.0	660.4	31.2	792.5
16	1.000	25.4	10.5	266.7	15.1	383.5	15.1	383.5	18.1	459.7	21.7	551.2	26.0	660.4	26.0	660.4	31.2	792.5	31.2	792.5
16	1.062	27.0	10.5	266.7	18.1	459.7	18.1	459.7	21.7	551.2	26.0	660.4	31.2	792.5	31.2	792.5	31.2	792.5	31.2	792.5
16	1.125	28.6	12.6	320.0	21.7	551.2	21.7	551.2	26.0	660.4	31.2	792.5	31.2	792.5	31.2	792.5	31.2	792.5	31.2	792.5
18	0.188	4.8	1.0	25.4	1.4	35.6	1.4	35.6	1.6	40.6	1.6	40.6	1.9	48.3	1.9	48.3	1.9	48.3	—	—
18	0.219	5.6	1.4	35.6	1.6	40.6	1.6	40.6	1.9	48.3	1.9	48.3	2.2	55.9	2.2	55.9	2.2	55.9	2.6	66.0
18	0.250	6.4	1.6	40.6	1.9	48.3	1.9	48.3	2.2	55.9	2.2	55.9	2.6	66.0	2.6	66.0	2.6	66.0	3.1	78.7
18	0.281	7.1	1.6	40.6	2.2	55.9	2.2	55.9	2.6	66.0	2.6	66.0	2.6	66.0	3.1	78.7	3.1	78.7	3.7	94.0
18	0.312	7.9	1.9	48.3	2.6	66.0	2.6	66.0	2.6	66.0	3.1	78.7	3.1	78.7	3.1	78.7	3.7	94.0	4.4	111.8
18	0.344	8.7	2.2	55.9	2.6	66.0	3.1	78.7	3.1	78.7	3.7	94.0	3.7	94.0	3.7	94.0	4.4	111.8	5.2	132.1
18	0.375	9.5	2.2	55.9	3.1	78.7	3.1	78.7	3.7	94.0	3.7	94.0	3.7	94.0	4.4	111.8	4.4	111.8	5.2	132.1
18	0.406	10.3	—	—	3.1	78.7	3.7	94.0	3.7	94.0	4.4	111.8	4.4	111.8	4.4	111.8	5.2	132.1	6.2	157.5
18	0.438	11.1	3.1	78.7	3.7	94.0	3.7	94.0	4.4	111.8	4.4	111.8	5.2	132.1	5.2	132.1	5.2	132.1	7.4	188.0
18	0.469	11.9	—	—	4.4	111.8	4.4	111.8	4.4	111.8	5.2	132.1	5.2	132.1	5.2	132.1	6.2	157.5	7.4	188.0
18	0.500	12.7	3.1	78.7	4.4	111.8	4.4	111.8	5.2	132.1	5.2	132.1	6.2	157.5	6.2	157.5	6.2	157.5	8.8	223.5
18	0.562	14.3	3.7	94.0	5.2	132.1	5.2	132.1	6.2	157.5	6.2	157.5	7.4	188.0	7.4	188.0	7.4	188.0	10.5	266.7
18	0.625	15.9	4.4	111.8	6.2	157.5	6.2	157.5	7.4	188.0	7.4	188.0	8.8	223.5	8.8	223.5	8.8	223.5	12.6	320.0
18	0.688	17.5	5.2	132.1	7.4	188.0	7.4	188.0	7.4	188.0	8.8	223.5	8.8	223.5	10.5	266.7	10.5	266.7	15.1	383.5
18	0.750	19.1	6.2	157.5	7.4	188.0	8.8	223.5	8.8	223.5	10.5	266.7	10.5	266.7	12.6	320.0	12.6	320.0	18.1	459.7
18	0.812	20.6	6.2	157.5	8.8	223.5	8.8	223.5	10.5	266.7	12.6	320.0	12.6	320.0	12.6	320.0	15.1	383.5	21.7	551.2
18	0.875	22.2	7.4	188.0	10.5	266.7	10.5	266.7	12.6	320.0	15.1	383.5	15.1	383.5	18.1	459.7	18.1	459.7	26.0	660.4
18	0.938	23.8	8.8	223.5	12.6	320.0	12.6	320.0	15.1	383.5	15.1	383.5	18.1	459.7	18.1	459.7	21.7	551.2	31.2	792.5
18	1.000	25.4	8.8	223.5	12.6	320.0	15.1	383.5	15.1	383.5	18.1	459.7	21.7	551.2	21.7	551.2	26.0	660.4	31.2	792.5
18	1.062	27.0	10.5	266.7	15.1	383.5	15.1	383.5	18.1	459.7	21.7	551.2	21.7	551.2	26.0	660.4	31.2	792.5	31.2	792.5
18	1.125	28.6	10.5	266.7	18.1	459.7	18.1	459.7	21.7	551.2	26.0	660.4	26.0	660.4	31.2	782.5	31.2	792.5	31.2	792.5
18	1.188	30.2	12.6	320.0	18.1	459.7	21.7	551.2	26.0	660.4	31.2	792.5	31.2	792.5	31.2	792.5	31.2	792.5	31.2	792.5
18	1.250	31.8	15.1	383.5	21.7	551.2	26.0	660.4	26.0	660.4	31.2	792.5	31.2	792.5	31.2	792.5	31.2	792.5	31.2	792.5
20	0.219	5.6	1.2	30.5	1.6	40.6	1.6	40.6	1.9	48.3	1.9	48.3	2.2	55.9	2.2	55.9	2.2	55.9	2.6	66.0
20	0.250	6.4	1.6	40.6	1.9	48.3	1.9	48.3	2.2	55.9	2.2	55.9	2.6	66.0	2.6	66.0	2.6	66.0	3.1	78.7
20	0.281	7.1	1.6	40.6	2.2	55.9	2.2	55.9	2.6	66.0	2.6	66.0	2.6	66.0	3.1	78.7	3.1	78.7	3.7	94.0
20	0.312	7.9	1.9	48.3	2.6	66.0	2.6	66.0	2.6	66.0	3.1	78.7	3.1	78.7	3.1	78.7	3.7	94.0	4.4	111.8
20	0.344	8.7	2.2	55.9	2.6	66.0	3.1	78.7	3.1	78.7	3.1	78.7	3.7	94.0	3.7	94.0	3.7	94.0	4.4	111.8
20	0.375	9.5	2.2	55.9	3.1	78.7	3.1	78.7	3.7	94.0	3.7	94.0	3.7	94.0	3.7	94.0	4.4	111.8	5.2	132.1
20	0.406	10.3	—	—	3.1	78.7	3.7	94.0	3.7	94.0	4.4	111.8	4.4	111.8	4.4	111.8	5.2	132.1	6.2	157.5
20	0.438	11.1	2.6	66.0	3.7	94.0	3.7	94.0	4.4	111.8	4.4	111.8	4.4	111.8	5.2	132.1	5.2	132.1	6.2	157.5
20	0.469	11.9	—	—	3.7	94.0	4.4	111.8	4.4	111.8	5.2	132.1	5.2	132.1	5.2	132.1	6.2	157.5	7.4	188.0
20	0.500	12.7	3.1	78.7	4.4	111.8	4.4	111.8	5.2	132.1	5.2	132.1	5.2	132.1	6.2	157.5	6.2	157.5	7.4	188.0
20	0.562	14.3	3.7	94.0	5.2	132.1	5.2	132.1	6.2	157.5	6.2	157.5	6.2	157.5	7.4	188.0	7.4	188.0	8.8	223.5
20	0.625	15.9	4.4	111.8	6.2	157.5	6.2	157.5	6.2	157.5	7.4	188.0	7.4	188.0	7.4	188.0	8.8	223.5	10.5	266.7
20	0.688	17.5	5.2	132.1	6.2	157.5	7.4	188.0	7.4	188.0	8.8	223.5	8.8	223.5	8.8	223.5	10.5	266.7	12.6	320.0

Table G-1—Guided-bend Test Jig Dimensions (Continued)

(1) Size	(2) Specified Wall Thickness <i>t</i>		(3)–(11) Dimension A Grade																	
			(4) A		(5) B & X42		(6) X46		(7) X52		(8) X56		(9) X60		(10) X65		(11) X70		(12) X80	
			in.	mm	in.	mm	in.	mm	in.	mm	in.	mm	in.	mm	in.	mm	in.	mm	in.	mm
20	0.750	19.1	5.2	132.1	7.4	188.0	7.4	188.0	8.8	223.5	8.8	223.5	10.5	266.7	10.5	266.7	12.6	320.0	15.1	383.5
20	0.812	20.6	6.2	157.5	8.8	223.5	8.8	223.5	10.5	266.7	10.5	266.7	12.6	320.0	12.6	320.0	15.1	383.5	18.1	459.7
20	0.875	22.2	7.4	188.0	8.8	223.5	10.5	266.7	10.5	266.7	12.6	320.0	12.6	320.0	15.1	383.5	15.1	383.5	21.7	551.2
20	0.938	23.8	7.4	188.0	10.5	266.7	10.5	266.7	12.6	320.0	15.1	383.5	15.1	383.5	18.1	459.7	18.1	459.7	26.0	660.4
20	1.000	25.4	8.8	223.5	12.6	320.0	12.6	320.0	15.1	383.5	15.1	383.5	18.1	459.7	18.1	459.7	21.7	551.2	31.2	792.5
20	1.062	27.0	8.8	223.5	12.6	320.0	15.1	383.5	15.1	383.5	18.1	459.7	21.7	551.2	21.7	551.2	26.0	660.4	31.2	792.5
20	1.125	28.6	10.5	266.7	15.1	383.5	15.1	383.5	18.1	459.7	21.7	551.2	21.7	551.2	26.0	660.4	31.2	792.5	31.2	792.5
20	1.188	30.2	10.5	266.7	18.1	459.7	18.1	459.7	21.7	551.2	26.0	660.4	26.0	660.4	26.0	660.4	31.2	792.5	31.2	792.5
20	1.250	31.8	12.6	320.0	18.1	459.7	21.7	551.2	21.7	551.2	26.0	660.4	31.2	792.5	31.2	792.5	31.2	792.5	31.2	792.5
20	1.312	33.3	12.6	320.0	21.7	551.2	21.7	551.2	26.0	660.4	31.2	792.5	31.2	792.5	31.2	792.5	31.2	792.5	31.2	792.5
20	1.375	34.9	15.1	383.5	21.7	551.2	26.0	660.4	31.2	792.5	31.2	792.5	31.2	792.5	31.2	792.5	31.2	792.5	31.2	792.5
22	0.219	5.6	1.2	30.5	1.6	40.6	1.6	40.6	1.9	48.3	1.9	48.3	2.2	55.9	2.2	55.9	2.2	55.9	2.6	66.0
22	0.250	6.4	1.4	35.6	1.9	48.3	1.9	48.3	2.2	55.9	2.2	55.9	2.6	66.0	2.6	66.0	2.6	66.0	3.1	78.7
22	0.281	7.1	1.6	40.6	2.2	55.9	2.2	55.9	2.6	66.0	2.6	66.0	2.6	66.0	2.6	66.0	3.1	78.7	3.7	94.0
22	0.312	7.9	1.9	48.3	2.6	66.0	2.6	66.0	2.6	66.0	3.1	78.7	3.1	78.7	3.1	78.7	3.7	94.0	4.4	111.8
22	0.344	8.7	2.2	55.9	2.6	66.0	2.6	66.0	3.1	78.7	3.1	78.7	3.7	94.0	3.7	94.0	3.7	94.0	4.4	111.8
22	0.375	9.5	2.2	55.9	3.1	78.7	3.1	78.7	3.1	78.7	3.7	94.0	3.7	94.0	3.7	94.0	4.4	111.8	5.2	132.1
22	0.406	10.3	—	—	3.1	78.7	3.7	94.0	3.7	94.0	3.7	94.0	4.4	111.8	4.4	111.8	4.4	111.8	6.2	157.5
22	0.438	11.1	2.6	66.0	3.7	94.0	3.7	94.0	3.7	94.0	4.4	111.8	4.4	111.8	5.2	132.1	5.2	132.1	6.2	157.5
22	0.469	11.9	—	—	3.7	94.0	4.4	111.8	4.4	111.8	4.4	111.8	5.2	132.1	5.2	132.1	6.2	157.5	7.4	188.0
22	0.500	12.7	3.1	78.7	4.4	111.8	4.4	111.8	4.4	111.8	5.2	132.1	5.2	132.1	5.2	132.1	6.2	157.5	7.4	188.0
22	0.562	14.3	3.7	94.0	5.2	132.1	5.2	132.1	5.2	132.1	6.2	157.5	6.2	157.5	6.2	157.5	7.4	188.0	8.8	223.5
22	0.625	15.9	4.4	111.8	5.2	132.1	6.2	157.5	6.2	157.5	7.4	188.0	7.4	188.0	7.4	188.0	8.8	223.5	10.5	266.7
22	0.688	17.5	5.2	132.1	6.2	157.5	6.2	157.5	7.4	188.0	7.4	188.0	8.8	223.5	8.8	223.5	10.5	266.7	12.6	320.0
22	0.750	19.1	5.2	132.1	7.4	188.0	7.4	188.0	8.8	223.5	8.8	223.5	10.5	266.7	10.5	266.7	10.5	266.7	15.1	383.5
22	0.812	20.6	6.2	157.5	7.4	188.0	8.8	223.5	8.8	223.5	10.5	266.7	10.5	266.7	10.5	266.7	12.6	320.0	15.1	383.5
22	0.875	22.2	6.2	157.5	8.8	223.5	8.8	223.5	10.5	266.7	12.6	320.0	12.6	320.0	12.6	320.0	15.1	383.5	18.1	459.7
22	0.938	23.8	7.4	188.0	10.5	266.7	10.5	266.7	12.6	320.0	12.6	320.0	15.1	383.5	15.1	383.5	18.1	459.7	21.7	551.2
22	1.000	25.4	7.4	188.0	10.5	266.7	12.6	320.0	12.6	320.0	15.1	383.5	15.1	383.5	18.1	459.7	18.1	459.7	26.0	660.4
22	1.062	27.0	8.8	223.5	12.6	320.0	12.6	320.0	15.1	383.5	15.1	383.5	18.1	459.7	18.1	459.7	21.7	551.2	31.2	792.5
22	1.125	28.6	10.5	266.7	12.6	320.0	15.1	383.5	15.1	383.5	18.1	459.7	21.7	551.2	21.7	551.2	26.0	660.4	31.2	792.5
22	1.188	30.2	10.5	266.7	15.1	383.5	15.1	383.5	18.1	459.7	21.7	551.2	21.7	551.2	26.0	660.4	31.2	792.5	31.2	792.5
22	1.250	31.8	12.6	320.0	18.1	459.7	18.1	459.7	21.7	551.2	21.7	551.2	26.0	660.4	26.0	660.4	31.2	792.5	31.2	792.5
22	1.312	33.3	12.6	320.0	18.1	459.7	21.7	551.2	21.7	551.2	26.0	660.4	31.2	792.5	31.2	792.5	31.2	792.5	31.2	792.5
22	1.375	34.9	12.6	320.0	21.7	551.2	21.7	551.2	26.0	660.4	31.2	792.5	31.2	792.5	31.2	792.5	31.2	792.5	31.2	792.5
22	1.438	36.5	15.1	383.5	21.7	551.2	26.0	660.4	31.2	792.5	31.2	792.5	31.2	792.5	31.2	792.5	31.2	792.5	31.2	792.5
22	1.500	38.1	15.1	383.5	26.0	660.4	26.0	660.4	31.2	792.5	31.2	792.5	31.2	792.5	31.2	792.5	31.2	792.5	31.2	792.5
24	0.250	6.4	1.4	35.6	1.9	48.3	1.9	48.3	2.2	55.9	2.2	55.9	2.2	55.9	2.6	66.0	2.6	66.0	3.1	78.7
24	0.281	7.1	1.6	40.6	2.2	55.9	2.2	55.9	2.2	55.9	2.6	66.0	2.6	66.0	2.6	66.0	3.1	78.7	3.7	94.0
24	0.312	7.9	1.9	48.3	2.2	55.9	2.6	66.0	2.6	66.0	3.1	78.7	3.1	78.7	3.1	78.7	3.7	94.0	4.4	111.8
24	0.344	8.7	2.2	55.9	2.6	66.0	2.6	66.0	3.1	78.7	3.1	78.7	3.7	94.0	3.7	94.0	3.7	94.0	4.4	111.8
24	0.375	9.5	2.2	55.9	3.1	78.7	3.1	78.7	3.1	78.7	3.7	94.0	3.7	94.0	3.7	94.0	4.4	111.8	5.2	132.1
24	0.406	10.3	—	—	3.1	78.7	3.1	78.7	3.7	94.0	3.7	94.0	4.4	111.8	4.4	111.8	4.4	111.8	5.2	132.1
24	0.438	11.1	2.6	66.0	3.7	94.0	3.7	94.0	3.7	94.0	4.4	111.8	4.4	111.8	4.4	111.8	5.2	132.1	6.2	157.5
24	0.469	11.9	—	—	3.7	94.0	3.7	94.0	4.4	111.8	4.4	111.8	5.2	132.1	5.2	132.1	5.2	132.1	6.2	157.5
24	0.500	12.7	3.1	78.7	4.4	111.8	4.4	111.8	4.4	111.8	5.2	132.1	5.2	132.1	5.2	132.1	6.2	157.5	7.4	188.0
24	0.562	14.3	3.7	94.0	4.4	111.8	5.2	132.1	5.2	132.1	6.2	157.5	6.2	157.5	6.5	157.5	7.4	188.0	8.8	223.5
24	0.625	15.9	4.4	111.8	5.2	132.1	6.2	157.5	6.2	157.5	7.4	188.0	7.4	188.0	8.8	223.5	8.8	223.5	10.5	266.7
24	0.688	17.5	4.4	111.8	6.2	157.5	6.2	157.5	7.4	188.0	7.4	188.0	8.8	223.5	8.8	223.5	8.8	223.5	12.6	320.0
24	0.750	19.1	5.2	132.1	7.4	188.0	7.4	188.0	8.8	223.5	8.8	223.5	10.5	266.7	10.5	266.7	10.5	266.7	15.1	383.5
24	0.812	20.6	6.2	157.5	7.4	188.0	8.8	223.5	8.8	223.5	10.5	266.7	10.5	266.7	10.5	266.7	12.6	320.0	15.1	383.5

Table G-1—Guided-bend Test Jig Dimensions (Continued)

(1)	(2)		(3)		(4)		(5)		(6)		(7)		(8)		(9)		(10)		(11)			
Size	Specified Wall Thickness <i>t</i>		Dimension A																			
			Grade																			
			A		B & X42		X46		X52		X56		X60		X65		X70		X80			
in.	mm	in.	mm	in.	mm	in.	mm	in.	mm	in.	mm	in.	mm	in.	mm	in.	mm	in.	mm			
24	0.875	22.2	6.2	157.5	8.8	223.5	8.8	223.5	10.5	266.7	10.5	266.7	12.6	320.0	12.6	320.0	12.6	320.0	15.1	383.5	21.7	551.2
24	0.938	23.8	7.4	188.0	8.8	223.5	10.5	266.7	10.5	266.7	12.6	320.0	12.6	320.0	15.1	383.5	15.1	383.5	18.1	459.7	21.7	551.2
24	1.000	25.4	7.4	188.0	10.5	266.7	10.5	266.7	12.6	320.0	12.6	320.0	15.1	383.5	15.1	383.5	18.1	459.7	18.1	459.7	26.0	660.4
24	1.062	27.0	8.8	223.5	12.6	320.0	12.6	320.0	12.6	320.0	15.1	383.5	15.1	383.5	18.1	459.7	18.1	459.7	21.7	551.2	31.2	792.5
24	1.125	28.6	8.8	223.5	12.6	320.0	12.6	320.0	15.1	383.5	18.1	459.7	18.1	459.7	18.1	459.7	21.7	551.2	21.7	551.2	31.2	792.5
24	1.188	30.2	10.5	266.7	15.1	383.5	15.1	383.5	18.1	459.7	18.1	459.7	21.7	551.2	21.7	551.2	26.0	660.4	26.0	660.4	31.2	792.5
24	1.250	31.8	10.5	266.7	15.1	383.5	15.1	383.5	18.1	459.7	21.7	551.2	21.7	551.2	26.0	660.4	26.0	660.4	26.0	660.4	31.2	792.5
24	1.312	33.3	12.6	320.0	18.1	459.7	18.1	459.7	21.7	551.2	21.7	551.2	26.0	660.4	26.0	660.4	31.2	792.5	31.2	792.5	31.2	792.5
24	1.375	34.9	12.6	320.0	18.1	459.7	21.7	551.2	21.7	551.2	26.0	660.4	31.2	792.5	31.2	792.5	31.2	792.5	31.2	792.5	31.2	792.5
24	1.438	36.5	15.1	383.5	21.7	551.2	21.7	551.2	26.0	660.4	31.2	792.5	31.2	792.5	31.2	792.5	31.2	792.5	31.2	792.5	31.2	792.5
24	1.500	38.1	15.1	383.5	21.7	551.2	26.0	660.4	26.0	660.4	31.2	792.5	31.2	792.5	31.2	792.5	31.2	792.5	31.2	792.5	31.2	792.5
24	1.562	39.7	15.1	383.5	26.0	660.4	26.0	660.4	31.2	792.5	31.2	792.5	31.2	792.5	31.2	792.5	31.2	792.5	31.2	792.5	31.2	792.5
26	0.250	6.4	1.4	35.6	1.9	48.3	1.9	48.3	2.2	55.9	2.2	55.9	2.2	55.9	2.6	66.0	2.6	66.0	3.1	78.7	3.7	94.0
26	0.281	7.1	1.6	40.6	2.2	55.9	2.2	55.9	2.2	55.9	2.6	66.0	2.6	66.0	2.6	66.0	2.6	66.0	3.1	78.7	3.7	94.0
26	0.312	7.9	1.9	48.3	2.2	55.9	2.6	66.0	2.6	66.0	3.1	78.7	3.1	78.7	3.1	78.7	3.1	78.7	3.1	78.7	3.7	94.0
26	0.344	8.7	2.2	55.9	2.6	66.0	2.6	66.0	3.1	78.7	3.1	78.7	3.7	94.0	3.7	94.0	3.7	94.0	3.7	94.0	4.4	111.8
26	0.375	9.5	2.2	55.9	3.1	78.7	3.1	78.7	3.1	78.7	3.7	94.0	3.7	94.0	3.7	94.0	3.7	94.0	4.4	111.8	5.2	132.1
26	0.406	10.3	—	—	3.1	78.7	3.1	78.7	3.7	94.0	3.7	94.0	4.4	111.8	4.4	111.8	4.4	111.8	4.4	111.8	5.2	132.1
26	0.438	11.1	2.6	66.0	3.7	94.0	3.7	94.0	3.7	94.0	4.4	111.8	4.4	111.8	4.4	111.8	4.4	111.8	5.2	132.1	6.2	157.5
26	0.469	11.9	—	—	3.7	94.0	3.7	94.0	4.4	111.8	4.4	111.8	5.2	132.1	5.2	132.1	5.2	132.1	5.2	132.1	6.2	157.5
26	0.500	12.7	3.1	78.7	3.7	94.0	4.4	111.8	4.4	111.8	5.2	132.1	5.2	132.1	5.2	132.1	5.2	132.1	6.2	157.5	7.4	188.0
26	0.562	14.3	3.7	94.0	4.4	111.8	5.1	132.1	5.2	132.1	6.2	157.5	6.2	157.5	6.2	157.5	6.2	157.5	7.4	188.0	8.8	223.5
26	0.625	15.9	4.4	111.8	5.2	132.1	5.2	132.1	6.2	157.5	6.2	157.5	7.4	188.0	7.4	188.0	7.4	188.0	7.4	188.0	10.5	266.7
26	0.688	17.5	4.4	111.8	6.2	157.5	6.2	157.5	7.4	188.0	7.4	188.0	7.4	188.0	8.8	223.5	8.8	223.5	8.8	223.5	10.5	266.7
26	0.750	19.1	5.2	132.1	6.2	157.5	7.4	188.0	7.4	188.0	8.8	223.5	8.8	223.5	8.8	223.5	8.8	223.5	10.5	266.7	12.6	320.0
26	0.812	20.6	5.2	132.1	7.4	188.0	7.4	188.0	8.8	223.5	8.8	223.5	10.5	266.7	10.5	266.7	10.5	266.7	12.6	320.0	15.1	383.5
26	0.875	22.2	6.2	157.5	8.8	223.5	8.8	223.5	8.8	223.5	10.5	266.7	10.5	266.7	12.6	320.0	12.6	320.0	12.6	320.0	15.1	383.5
26	0.938	23.8	7.4	188.0	8.8	223.5	10.5	266.7	10.5	266.7	12.6	320.0	12.6	320.0	12.6	320.0	12.6	320.0	15.1	383.5	18.1	459.7
26	1.000	25.4	7.4	188.0	10.5	266.7	10.5	266.7	12.6	320.0	12.6	320.0	15.1	383.5	15.1	383.5	15.1	383.5	15.1	383.5	21.7	551.2
28	0.250	6.4	1.4	35.6	1.9	48.3	1.9	48.3	2.2	55.9	2.2	55.9	2.2	55.9	2.2	55.9	2.6	66.0	3.1	78.7	3.7	94.0
28	0.281	7.1	1.6	40.6	2.2	55.9	2.2	55.9	2.2	55.9	2.6	66.0	2.6	66.0	2.6	66.0	2.6	66.0	3.1	78.7	3.7	94.0
28	0.312	7.9	1.9	48.3	2.2	55.9	2.6	66.0	2.6	66.0	3.1	78.7	3.1	78.7	3.1	78.7	3.1	78.7	3.1	78.7	3.7	94.0
28	0.344	8.7	—	—	2.6	66.0	2.6	66.0	3.1	78.7	3.1	78.7	3.7	94.0	3.7	94.0	3.7	94.0	3.7	94.0	4.4	111.8
28	0.375	9.5	2.2	55.9	3.1	78.7	3.1	78.7	3.1	78.7	3.7	94.0	3.7	94.0	3.7	94.0	3.7	94.0	4.4	111.8	5.2	132.1
28	0.406	10.3	—	—	3.1	78.7	3.1	78.7	3.7	94.0	3.7	94.0	3.7	94.0	4.4	111.8	4.4	111.8	4.4	111.8	5.2	132.1
28	0.438	11.1	2.6	66.0	3.7	94.0	3.7	94.0	3.7	94.0	4.4	111.8	4.4	111.8	4.4	111.8	4.4	111.8	5.2	132.1	6.2	157.5
28	0.469	11.9	—	—	3.7	94.0	3.7	94.0	4.4	111.8	4.4	111.8	4.4	111.8	5.2	132.1	5.2	132.1	5.2	132.1	6.2	157.5
28	0.500	12.7	3.1	78.7	3.7	94.0	4.4	111.8	4.4	111.8	5.2	132.1	5.2	132.1	5.2	132.1	5.2	132.1	6.2	157.5	7.4	188.0
28	0.562	14.3	3.7	94.0	4.4	111.8	5.2	132.1	5.2	132.1	6.2	157.5	6.2	157.5	6.2	157.5	6.2	157.5	6.2	157.5	8.8	223.5
28	0.625	15.9	3.7	94.0	5.2	132.1	5.2	132.1	6.2	157.5	6.2	157.5	7.4	188.0	7.4	188.0	7.4	188.0	7.4	188.0	8.8	223.5
28	0.688	17.5	4.4	111.8	6.2	157.5	6.2	157.5	7.4	188.0	7.4	188.0	7.4	188.0	8.8	223.5	8.8	223.5	8.8	223.5	10.5	266.7
28	0.750	19.1	5.2	132.1	6.2	157.5	7.4	188.0	7.4	188.0	8.8	223.5	8.8	223.5	8.8	223.5	8.8	223.5	10.5	266.7	12.6	320.0
28	0.812	20.6	5.2	132.1	7.4	188.0	7.4	188.0	8.8	223.5	8.8	223.5	10.5	266.7	10.5	266.7	10.5	266.7	10.5	266.7	12.6	320.0
28	0.875	22.2	6.2	157.5	7.4	188.0	8.8	223.5	8.8	223.5	10.5	266.7	10.5	266.7	10.5	266.7	10.5	266.7	12.6	320.0	15.1	383.5
28	0.938	23.8	6.2	157.5	8.8	223.5	8.8	223.5	10.5	266.7	10.5	266.7	12.6	320.0	12.6	320.0	12.6	320.0	15.1	383.5	18.1	459.7
28	1.000	25.4	7.4	188.0	10.5	266.7	10.5	266.7	10.5	266.7	12.6	320.0	12.6	320.0	12.6	320.0	12.6	320.0	15.1	383.5	18.1	459.7
30	0.250	6.4	1.4	35.6	1.9	48.3	1.9	48.3	2.2	55.9	2.2	55.9	2.2	55.9	2.2	55.9	2.6	66.0	3.1	78.7	3.7	94.0
30	0.281	7.1	1.6	40.6	2.2	55.9	2.2	55.9	2.2	55.9	2.6	66.0	2.6	66.0	2.6	66.0	2.6	66.0	3.1	78.7	3.7	94.0
30	0.312	7.9	1.9	48.3	2.2	55.9	2.6	66.0	2.6	66.0	3.1	78.7	3.1	78.7	3.1	78.7	3.1	78.7	3.1	78.7	3.7	94.0
30	0.344	8.7	—	—	2.6	66.0	2.6	66.0	3.1	78.7	3.1	78.7	3.7	94.0	3.7	94.0	3.7	94.0	3.7	94.0	4.4	111.8

Table G-1—Guided-bend Test Jig Dimensions (Continued)

(1)	(2)		(3)		(4)		(5)		(6)		(7)		(8)		(9)		(10)		(11)																		
																					Specified Wall Thickness <i>t</i>	Dimension A															
																						Grade															
Size			A		B & X42		X46		X52		X56		X60		X65		X70		X80																		
	in.	mm	in.	mm	in.	mm	in.	mm	in.	mm	in.	mm	in.	mm	in.	mm	in.	mm	in.	mm																	
30	0.375	9.5	2.2	55.9	2.6	66.0	3.1	78.7	3.1	78.7	3.7	94.0	3.7	94.0	3.7	94.0	4.4	111.8	5.2	132.1																	
30	0.406	10.3	-	-	3.1	78.7	3.1	78.7	3.7	94.0	3.7	94.0	3.7	94.0	4.4	111.8	4.4	111.8	5.2	132.1																	
30	0.438	11.1	2.6	66.0	3.1	78.7	3.7	94.0	3.7	94.0	4.4	111.8	4.4	111.8	4.4	111.8	5.2	132.1	6.2	157.5																	
30	0.469	11.9	-	-	3.7	94.0	3.7	94.0	4.4	111.8	4.4	111.8	4.4	111.8	5.2	132.1	5.2	132.1	6.2	157.5																	
30	0.500	12.7	3.1	78.7	3.7	94.0	4.4	111.8	4.4	111.8	5.2	132.1	5.2	132.1	5.2	132.1	6.2	157.5	7.4	188.0																	
30	0.562	14.3	3.7	94.0	4.4	111.8	4.4	111.8	5.2	132.1	5.2	132.1	6.2	157.5	6.2	157.5	6.2	157.5	7.4	188.0																	
30	0.625	15.9	3.7	94.0	5.2	132.1	5.2	132.1	6.2	157.5	6.2	157.5	6.2	157.5	7.4	188.0	7.4	188.0	8.8	223.5																	
30	0.688	17.5	4.4	111.8	6.2	157.5	6.2	157.5	6.2	157.5	7.4	188.0	7.4	188.0	7.4	188.0	8.8	223.5	10.5	266.7																	
30	0.750	19.1	5.2	132.1	6.2	157.5	6.2	157.5	7.4	188.0	7.4	188.0	8.8	223.5	8.8	223.5	10.5	266.7	12.6	320.0																	
30	0.812	20.6	5.2	132.1	7.4	188.0	7.4	188.0	8.8	223.5	8.8	223.5	8.8	223.5	10.5	266.7	10.5	266.7	12.6	320.0																	
30	0.875	22.2	6.2	157.5	7.4	188.0	8.8	223.5	8.8	223.5	10.5	266.7	10.5	266.7	10.5	266.7	12.6	320.0	15.1	383.5																	
30	0.938	23.8	6.2	157.5	8.8	223.5	8.8	223.5	10.5	266.7	10.5	266.7	12.6	320.0	12.6	320.0	12.6	320.0	18.1	459.7																	
30	1.000	25.4	7.4	188.0	8.8	223.5	10.5	266.7	10.5	266.7	12.6	320.0	12.6	320.0	12.6	320.0	15.1	383.5	18.1	459.7																	
32	0.250	6.4	1.4	35.6	1.9	48.3	1.9	48.3	2.2	55.9	2.2	55.9	2.2	55.9	2.2	55.9	2.6	66.0	3.1	78.7																	
32	0.281	7.1	1.6	40.6	2.2	55.9	2.2	55.9	2.2	55.9	2.6	66.0	2.6	66.0	2.6	66.0	3.1	78.7	3.7	94.0																	
32	0.312	7.9	1.9	48.3	2.2	55.9	2.6	66.0	2.6	66.0	2.6	66.0	3.1	78.7	3.1	78.7	3.1	78.7	3.7	94.0																	
32	0.344	8.7	-	-	2.6	66.0	2.6	66.0	3.1	78.7	3.1	78.7	3.1	78.7	3.1	78.7	3.7	94.0	4.4	111.8																	
32	0.375	9.5	2.2	55.9	2.6	66.0	3.1	78.7	3.1	78.7	3.7	94.0	3.7	94.0	3.7	94.0	3.7	94.0	5.2	132.1																	
32	0.406	10.3	-	-	3.1	78.7	3.1	78.7	3.7	94.0	3.7	94.0	3.7	94.0	4.4	111.8	4.4	111.8	5.7	144.8																	
32	0.438	11.1	2.6	66.0	3.1	78.7	3.7	94.0	3.7	94.0	4.4	111.8	4.4	111.8	4.4	111.8	5.2	132.1	6.2	157.5																	
32	0.469	11.9	-	-	3.7	94.0	3.7	94.0	4.4	111.8	4.4	111.8	4.4	111.8	5.2	132.1	5.2	132.1	6.2	157.5																	
32	0.500	12.7	3.1	78.7	3.7	94.0	4.4	111.8	4.4	111.8	4.4	111.8	5.2	132.1	5.2	132.1	5.2	132.1	6.2	157.5																	
32	0.562	14.3	3.7	94.0	4.4	111.8	4.4	111.8	5.2	132.1	5.2	132.1	6.2	157.5	6.2	157.5	6.2	157.5	7.4	188.0																	
32	0.625	15.9	3.7	94.0	5.2	132.1	5.2	132.1	6.2	157.5	6.2	157.5	6.2	157.5	6.2	157.5	7.4	188.0	8.8	223.5																	
32	0.688	17.5	4.4	111.8	5.2	132.1	6.2	157.5	6.2	157.5	7.4	188.0	7.4	188.0	7.4	188.0	8.8	223.5	10.5	266.7																	
32	0.750	19.1	5.2	132.1	6.2	157.5	6.2	157.5	7.4	188.0	7.4	188.0	8.8	223.5	8.8	223.5	8.8	223.5	10.5	266.7																	
32	0.812	20.6	5.2	132.1	7.4	188.0	7.4	188.0	7.4	188.0	8.8	223.5	8.8	223.5	8.8	223.5	10.5	266.7	12.6	320.0																	
32	0.875	22.2	6.2	157.5	7.4	188.0	8.8	223.5	8.8	223.5	8.8	223.5	10.5	266.7	10.5	266.7	12.6	320.0	15.1	383.5																	
32	0.938	23.8	6.2	157.5	8.8	223.5	8.8	223.5	10.5	266.7	10.5	266.7	10.5	266.7	12.6	320.0	12.6	320.0	15.1	383.5																	
32	1.000	25.4	7.4	188.0	8.8	223.5	10.5	266.7	10.5	266.7	12.6	320.0	12.6	320.0	12.6	320.0	15.1	383.5	18.1	459.7																	
32	1.062	27.0	7.4	188.0	10.5	266.7	10.5	266.7	10.5	266.7	12.6	320.0	12.6	320.0	15.1	383.5	15.1	383.5	18.1	459.7																	
32	1.125	28.6	8.8	223.5	10.5	266.7	10.5	266.7	12.6	320.0	15.1	383.5	15.1	383.5	15.1	383.5	18.1	459.7	21.7	551.2																	
32	1.188	30.2	8.8	223.5	12.6	320.0	12.6	320.0	12.6	320.0	15.1	383.5	15.1	383.5	18.1	459.7	18.1	459.7	26.0	660.4																	
32	1.250	31.8	8.8	223.5	12.6	320.0	12.6	320.0	15.1	383.5	15.1	383.5	18.1	459.7	18.1	459.7	21.7	551.2	26.0	660.4																	
34	0.250	6.4	1.4	35.6	1.9	48.3	1.9	48.3	1.9	48.3	2.2	55.9	2.2	55.9	2.2	55.9	2.6	66.0	3.1	78.7																	
34	0.281	7.1	1.6	40.6	2.2	55.9	2.2	55.9	2.2	55.9	2.6	66.0	2.6	66.0	2.6	66.0	3.1	78.7	3.7	94.0																	
34	0.312	7.9	1.9	48.3	2.2	55.9	2.6	66.0	2.6	66.0	2.6	66.0	3.1	78.7	3.1	78.7	3.1	78.7	3.7	94.0																	
34	0.344	8.7	-	-	2.6	66.0	2.6	66.0	3.1	78.7	3.1	78.7	3.1	78.7	3.1	78.7	3.7	94.0	4.4	111.8																	
34	0.375	9.5	2.2	55.9	2.6	66.0	3.1	78.7	3.1	78.7	3.1	78.7	3.7	94.0	3.7	94.0	3.7	94.0	4.4	111.8																	
34	0.406	10.3	-	-	3.1	78.7	3.1	78.7	3.7	94.0	3.7	94.0	3.7	94.0	3.7	94.0	4.4	111.8	5.2	132.1																	
34	0.438	11.1	2.6	66.0	3.1	78.7	3.7	94.0	3.7	94.0	3.7	94.0	4.4	111.8	4.4	111.8	5.2	132.1	5.2	132.1																	
34	0.469	11.9	-	-	3.7	94.0	3.7	94.0	3.7	94.0	4.4	111.8	4.4	111.8	4.4	111.8	5.2	132.1	6.2	157.5																	
34	0.500	12.7	3.1	78.7	3.7	94.0	4.4	111.8	4.4	111.8	4.4	111.8	5.2	132.1	5.2	132.1	5.2	132.1	6.2	157.5																	
34	0.562	14.3	3.7	94.0	4.4	111.8	4.4	111.8	5.2	132.1	5.2	132.1	6.2	157.5	6.2	157.5	6.2	157.5	7.4	188.0																	
34	0.625	15.9	3.7	94.0	5.2	132.1	5.2	132.1	5.2	132.1	6.2	157.5	6.2	157.5	6.2	157.5	7.4	188.0	8.8	223.5																	
34	0.688	17.5	4.4	111.8	5.2	132.1	6.2	157.5	6.2	157.5	7.4	188.0	7.4	188.0	7.4	188.0	8.8	223.5	10.5	266.7																	
34	0.750	19.1	5.2	132.1	6.2	157.5	6.2	157.5	7.4	188.0	7.4	188.0	8.8	223.5	8.8	223.5	8.8	223.5	10.5	266.7																	
34	0.812	20.6	5.2	132.1	7.4	188.0	7.4	188.0	7.4	188.0	8.8	223.5	8.8	223.5	8.8	223.5	10.5	266.7	15.0	381.0																	
34	0.875	22.2	6.2	157.5	7.4	188.0	7.4	188.0	8.8	223.5	8.8	223.5	10.5	266.7	10.5	266.7	10.5	266.7	15.1	383.5																	
34	0.938	23.8	6.2	157.5	8.8	223.5	8.8	223.5	8.8	223.5	10.5	266.7	10.5	266.7	10.5	266.7	12.6	320.0	15.1	383.5																	
34	1.000	25.4	7.4	188.0	8.8	223.5	8.8	223.5	10.5	266.7	10.5	266.7	12.6	320.0	12.6	320.0	15.1	383.5	18.1	459.7																	

Table G-1—Guided-bend Test Jig Dimensions (Continued)

(1) Size	(2) Specified Wall Thickness <i>t</i> in. mm		(3)–(11) Dimension A Grade																	
			(4) A		(5) B & X42		(6) X46		(7) X52		(8) X56		(9) X60		(10) X65		(11) X70		(12) X80	
			in.	mm	in.	mm	in.	mm	in.	mm	in.	mm	in.	mm	in.	mm	in.	mm	in.	mm
34	1.062	27.0	7.4	188.0	10.5	266.7	10.5	266.7	10.5	266.7	12.6	320.0	12.6	320.0	12.6	320.0	15.1	383.5	18.1	459.7
34	1.125	28.6	7.4	188.0	10.5	266.7	10.5	266.7	12.6	320.0	12.6	320.0	15.1	383.5	15.1	383.5	18.1	459.7	21.7	551.2
34	1.188	30.2	8.8	223.5	10.5	266.7	12.6	320.0	12.6	320.0	15.1	383.5	15.1	383.5	15.1	383.5	18.1	459.7	21.7	551.2
34	1.250	31.8	8.8	223.5	12.6	320.0	12.6	320.0	15.1	383.5	15.1	383.5	18.1	459.7	18.1	459.7	18.1	459.7	26.0	660.4
36	0.250	6.4	1.4	35.6	1.9	48.3	1.9	48.3	1.9	48.3	2.2	55.9	2.2	55.9	2.2	55.9	2.6	66.0	3.1	78.7
36	0.281	7.1	1.6	40.6	2.2	55.9	2.2	55.9	2.2	55.9	2.6	66.0	2.6	66.0	2.6	66.0	3.1	78.7	3.7	94.0
36	0.312	7.9	1.9	48.3	2.2	55.9	2.2	55.9	2.6	66.0	2.6	66.0	3.1	78.7	3.1	78.7	3.1	78.7	3.7	94.0
36	0.344	8.7	—	—	2.6	66.0	2.6	66.0	2.6	66.0	3.1	78.7	3.1	78.7	3.1	78.7	3.7	94.0	4.4	111.8
36	0.375	9.5	2.2	55.9	2.6	66.0	3.1	78.7	3.1	78.7	3.1	78.7	3.7	94.0	3.7	94.0	3.7	94.0	4.4	111.8
36	0.406	10.3	—	—	3.1	78.7	3.1	78.7	3.7	94.0	3.7	94.0	3.7	94.0	3.7	94.0	4.4	111.8	5.2	132.1
36	0.438	11.1	2.6	66.0	3.1	78.7	3.7	94.0	3.7	94.0	3.7	94.0	4.4	111.8	4.4	111.8	4.4	111.8	5.2	132.1
36	0.469	11.9	—	—	3.7	94.0	3.7	94.0	3.7	94.0	4.4	111.8	4.4	111.8	4.4	111.8	5.2	132.1	6.2	157.5
36	0.500	12.7	3.1	78.7	3.7	94.0	3.7	94.0	4.4	111.8	4.4	111.8	5.2	132.1	5.2	132.1	5.2	132.1	6.2	157.5
36	0.562	14.3	3.7	94.0	4.4	111.8	4.4	111.8	5.2	132.1	5.2	132.1	5.2	132.1	6.2	157.5	6.2	157.5	7.4	188.0
36	0.625	15.9	3.7	94.0	5.2	132.1	5.2	132.1	5.2	132.1	6.2	157.5	6.2	157.5	6.2	157.5	7.4	188.0	8.8	223.5
36	0.688	17.5	4.4	111.8	5.2	132.1	6.2	157.5	6.2	157.5	7.4	188.0	7.4	188.0	7.4	188.0	8.8	223.5	10.5	266.7
36	0.750	19.1	4.4	111.8	6.2	157.5	6.2	157.5	7.4	188.0	7.4	188.0	8.8	223.5	8.8	223.5	8.8	223.5	10.5	266.7
36	0.812	20.6	5.2	132.1	6.2	157.5	7.4	188.0	7.4	188.0	8.8	223.5	8.8	223.5	8.8	223.5	10.5	266.7	12.6	320.0
36	0.875	22.2	6.2	157.5	7.4	188.0	7.4	188.0	8.8	223.5	8.8	223.5	10.5	266.7	10.5	266.7	10.5	266.7	12.6	320.0
36	0.938	23.8	6.2	157.5	8.8	223.5	8.8	223.5	8.8	223.5	10.5	266.7	10.5	266.7	10.5	266.7	12.6	320.0	15.1	383.5
36	1.000	25.4	6.2	157.5	8.8	223.5	8.8	223.5	10.5	266.7	10.5	266.7	12.6	320.0	12.6	320.0	12.6	320.0	15.1	383.5
36	1.062	27.0	7.4	188.0	8.8	223.5	10.5	266.7	10.5	266.7	12.6	320.0	12.6	320.0	12.6	320.0	15.1	383.5	18.1	459.7
36	1.125	28.6	7.4	188.0	10.5	266.7	10.5	266.7	12.6	320.0	12.6	320.0	15.1	383.5	15.1	383.5	15.1	383.5	21.7	551.2
36	1.188	30.2	8.8	223.5	10.5	266.7	12.6	320.0	12.6	320.0	15.1	383.5	15.1	383.5	15.1	383.5	18.1	459.7	21.7	551.2
36	1.250	31.8	8.8	223.5	12.6	320.0	12.6	320.0	15.1	383.5	15.1	383.5	15.1	383.5	18.1	459.7	18.1	459.7	26.0	660.4
38	0.312	7.9	1.9	48.3	2.2	55.9	2.2	55.9	2.6	66.0	2.6	66.0	3.1	78.7	3.1	78.7	3.1	78.7	3.7	94.0
38	0.344	8.7	1.9	48.3	2.6	66.0	2.6	66.0	2.6	66.0	3.1	78.7	3.1	78.7	3.1	78.7	3.7	94.0	4.4	111.8
38	0.375	9.5	2.2	55.9	2.6	66.0	3.1	78.7	3.1	78.7	3.1	78.7	3.7	94.0	3.7	94.0	3.7	94.0	4.4	111.8
38	0.406	10.3	2.2	55.9	3.1	78.7	3.1	78.7	3.1	78.7	3.7	94.0	3.7	94.0	3.7	94.0	4.4	111.8	5.2	132.1
38	0.438	11.1	2.6	66.0	3.1	78.7	3.7	94.0	3.7	94.0	3.7	94.0	4.4	111.8	4.4	111.8	4.4	111.8	5.2	132.1
38	0.469	11.9	2.6	66.0	3.7	94.0	3.7	94.0	3.7	94.0	4.4	111.8	4.4	111.8	4.4	111.8	5.2	132.1	6.2	157.5
38	0.500	12.7	3.1	78.7	3.7	94.0	3.7	94.0	4.4	111.8	4.4	111.8	5.2	132.1	5.2	132.1	5.2	132.1	6.2	157.5
38	0.562	14.3	3.1	78.7	4.4	111.8	4.4	111.8	5.2	132.1	5.2	132.1	5.2	132.1	6.2	157.5	6.2	157.5	7.4	188.0
38	0.625	15.9	3.7	94.0	5.2	132.1	5.2	132.1	5.2	132.1	6.2	157.5	6.2	157.5	6.2	157.5	7.4	188.0	8.8	223.5
38	0.688	17.5	4.4	111.8	5.2	132.1	6.2	157.5	6.2	157.5	6.2	157.5	7.4	188.0	7.4	188.0	7.4	188.0	8.8	223.5
38	0.750	19.1	4.4	111.8	6.2	157.5	6.2	157.5	7.4	188.0	7.4	188.0	7.4	188.0	8.8	223.5	8.8	223.5	10.5	266.7
38	0.812	20.6	5.2	132.1	6.2	157.5	7.4	188.0	7.4	188.0	8.8	223.5	8.8	223.5	8.8	223.5	10.5	266.7	12.6	320.0
38	0.875	22.2	5.2	132.1	7.4	188.0	7.4	188.0	8.8	223.5	8.8	223.5	10.5	266.7	10.5	266.7	10.5	266.7	12.6	320.0
38	0.938	23.8	6.2	157.1	7.4	188.0	8.8	223.5	8.8	223.5	10.5	266.7	10.5	266.7	10.5	266.7	12.6	320.0	15.1	383.5
38	1.000	25.4	6.2	157.1	8.8	223.5	8.8	223.5	10.5	266.7	10.5	266.7	12.6	320.0	12.6	320.0	12.6	320.0	15.1	383.5
38	1.062	27.0	7.4	188.0	8.8	223.5	10.5	266.7	10.5	266.7	12.6	320.0	12.6	320.0	12.6	320.0	15.1	383.5	18.1	459.7
38	1.125	28.6	7.4	188.0	10.5	266.7	10.5	266.7	12.6	320.0	12.6	320.0	12.6	320.0	15.1	383.5	15.1	383.5	18.1	459.7
38	1.188	30.2	8.8	223.5	10.5	266.7	10.5	266.7	12.6	320.0	12.6	320.0	15.1	383.5	15.1	383.5	18.1	459.7	21.7	551.2
38	1.250	31.8	8.8	223.5	12.6	320.0	12.6	320.0	12.6	320.0	15.1	383.5	15.1	383.5	15.1	383.5	18.1	459.7	21.7	551.2
40	0.312	7.9	1.9	48.3	2.2	55.9	2.2	55.9	2.6	66.0	2.6	66.0	3.1	78.7	3.1	78.7	3.1	78.7	3.7	94.0
40	0.344	8.7	1.9	48.3	2.6	66.0	2.6	66.0	2.6	66.0	3.1	78.7	3.1	78.7	3.1	78.7	3.7	94.0	4.4	111.8
40	0.375	9.5	2.2	55.9	2.6	66.0	3.1	78.7	3.1	78.7	3.1	78.7	3.7	94.0	3.7	94.0	3.7	94.0	4.4	111.8
40	0.406	10.3	2.2	55.9	3.1	78.7	3.1	78.7	3.1	78.7	3.7	94.0	3.7	94.0	3.7	94.0	4.4	111.8	5.2	132.1
40	0.438	11.1	2.6	66.0	3.1	78.7	3.7	94.0	3.7	94.0	3.7	94.0	4.4	111.8	4.4	111.8	4.4	111.8	5.2	132.1

Table G-1—Guided-bend Test Jig Dimensions (Continued)

(1)	(2) Specified Wall Thickness <i>t</i>		(3)–(11) Dimension A Grade																	
			(4) A		(5) B & X42		(6) X46		(7) X52		(8) X56		(9) X60		(10) X65		(11) X70		(12) X80	
			in.	mm	in.	mm	in.	mm	in.	mm	in.	mm	in.	mm	in.	mm	in.	mm	in.	mm
40	0.469	11.9	2.6	66.0	3.7	94.0	3.7	94.0	3.7	94.0	4.4	111.8	4.4	111.8	4.4	111.8	5.2	132.1	6.2	157.5
40	0.500	12.7	3.1	78.7	3.7	94.0	3.7	94.0	4.4	111.8	4.4	111.8	5.2	132.1	5.2	132.1	5.2	132.1	6.2	157.5
40	0.562	14.3	3.1	78.7	4.4	111.8	4.4	111.8	5.2	132.1	5.2	132.1	5.2	132.1	6.2	157.5	6.2	157.5	7.4	188.0
40	0.625	15.9	3.7	94.0	5.2	132.1	5.2	132.1	5.2	132.1	6.2	157.5	6.2	157.5	6.2	157.4	7.4	188.0	8.8	223.5
40	0.688	17.5	4.4	111.8	5.2	132.1	6.2	157.5	6.2	157.5	6.2	157.5	7.4	188.0	7.4	188.0	7.4	188.0	8.8	223.5
40	0.750	19.1	4.4	111.8	6.2	157.5	6.2	157.5	7.4	188.0	7.4	188.0	7.4	188.0	7.4	188.0	8.8	223.5	10.5	266.7
40	0.812	20.6	5.2	132.1	6.2	157.5	7.4	188.0	7.4	188.0	8.8	223.5	8.8	223.5	8.8	223.5	10.5	266.7	12.6	320.0
40	0.875	22.2	5.2	132.1	7.4	188.0	7.4	188.0	8.8	223.5	8.8	223.5	8.8	223.5	10.5	266.7	10.5	266.7	12.6	320.0
40	0.938	23.8	6.2	157.5	7.4	188.0	8.8	223.5	8.8	223.5	10.5	266.7	10.5	266.7	10.5	266.7	12.6	320.0	15.1	383.5
40	1.000	25.4	6.2	157.5	8.8	223.5	8.8	223.5	10.5	266.7	10.5	266.7	10.5	266.7	12.6	320.0	12.6	320.0	15.1	383.5
40	1.062	27.0	7.4	188.0	8.8	223.5	10.5	266.7	10.5	266.7	10.5	266.7	12.6	320.0	12.6	320.0	15.1	383.5	18.1	459.7
40	1.125	28.6	7.4	188.0	10.5	266.7	10.5	266.7	10.5	266.7	12.6	320.0	12.6	320.0	12.6	320.0	15.1	383.5	18.1	459.7
40	1.188	30.2	8.8	223.5	10.5	266.7	10.5	266.7	12.6	320.0	12.6	320.0	15.1	383.5	15.1	383.5	15.1	383.5	21.7	551.2
40	1.250	31.8	8.8	223.5	10.5	266.7	12.6	320.0	12.6	320.0	15.1	383.5	15.1	383.5	15.1	383.5	18.1	459.7	21.7	551.2
42	0.344	8.7	1.9	48.3	2.6	66.0	2.6	66.0	2.6	66.0	3.1	78.7	3.1	78.7	3.1	78.7	3.7	94.0	4.4	111.8
42	0.375	9.5	2.2	55.9	2.6	66.0	3.1	78.7	3.1	78.7	3.1	78.7	3.1	78.7	3.7	94.0	3.7	94.0	3.7	94.0
42	0.406	10.3	2.2	55.9	3.1	78.7	3.1	78.7	3.1	78.7	3.7	94.0	3.7	94.0	3.7	94.0	4.4	111.8	5.2	132.1
42	0.438	11.1	2.6	66.0	3.1	78.7	3.1	78.7	3.7	94.0	3.7	94.0	4.4	111.8	4.4	111.8	4.4	111.8	5.2	132.1
42	0.469	11.9	2.6	66.0	3.7	94.0	3.7	94.0	3.7	94.0	4.4	111.8	4.4	111.8	4.4	111.8	5.2	132.1	6.2	157.5
42	0.500	12.7	3.1	78.7	3.7	94.0	3.7	94.0	4.4	111.8	4.4	111.8	5.2	132.1	5.2	132.1	5.2	132.1	6.2	157.5
42	0.562	14.3	3.1	78.7	4.4	111.8	4.4	111.8	5.2	132.1	5.2	132.1	5.2	132.1	5.2	132.1	6.2	157.5	7.4	188.0
42	0.625	15.9	3.7	94.0	5.2	132.1	5.2	132.1	5.2	132.1	6.2	157.5	6.2	157.5	6.2	157.5	7.4	188.0	8.8	223.5
42	0.688	17.5	4.4	111.8	5.2	132.1	5.2	132.1	6.2	157.5	6.2	157.5	7.4	188.0	7.4	188.0	7.4	188.0	8.8	223.5
42	0.750	19.1	4.4	111.8	6.2	157.5	6.2	157.5	6.2	157.5	7.4	188.0	7.4	188.0	7.4	188.0	8.8	223.5	10.5	266.7
42	0.812	20.6	5.2	132.1	6.2	157.5	7.4	188.0	7.4	188.0	7.4	188.0	8.8	223.5	8.8	223.5	10.5	266.7	10.5	266.7
42	0.875	22.2	5.2	132.1	7.4	188.0	7.4	188.0	8.8	223.5	8.8	223.5	8.8	223.5	10.5	266.7	10.5	266.7	12.6	320.0
42	0.938	23.8	6.2	157.5	7.4	188.0	8.8	223.5	8.8	223.5	10.5	266.7	10.5	266.7	10.5	266.7	12.6	320.0	15.1	383.5
42	1.000	25.4	6.2	157.5	8.8	223.5	8.8	223.5	10.5	266.7	10.5	266.7	10.5	266.7	10.5	266.7	12.6	320.0	15.1	383.5
42	1.062	27.0	7.4	188.0	8.8	223.5	8.8	223.5	10.5	266.7	10.5	266.7	12.6	320.0	12.6	320.0	12.6	320.0	18.1	459.7
42	1.125	28.6	7.4	188.0	10.5	266.7	10.5	266.7	10.5	266.7	12.6	320.0	12.6	320.0	12.6	320.0	15.1	383.5	18.1	459.7
42	1.188	30.2	7.4	188.0	10.5	266.7	10.5	266.7	12.6	320.0	12.6	320.0	15.1	383.5	15.1	383.5	15.1	383.5	18.1	459.7
42	1.250	31.8	8.8	223.5	10.5	266.7	12.6	320.0	12.6	320.0	15.1	383.5	15.1	383.5	15.1	383.5	18.1	459.7	21.7	551.2
44	0.344	8.7	1.9	48.3	2.6	66.0	2.6	66.0	2.6	66.0	3.1	78.7	3.1	78.7	3.1	78.7	3.7	94.0	4.4	111.8
44	0.375	9.5	2.2	55.9	2.6	66.0	3.1	78.7	3.1	78.7	3.1	78.7	3.1	78.7	3.7	94.0	3.7	94.0	3.7	94.0
44	0.406	10.3	2.2	55.9	3.1	78.7	3.1	78.7	3.1	78.7	3.7	94.0	3.7	94.0	3.7	94.0	4.4	111.8	5.2	132.1
44	0.438	11.1	2.6	66.0	3.1	78.7	3.1	78.7	3.7	94.0	3.7	94.0	4.4	111.8	4.4	111.8	4.4	111.8	5.2	132.1
44	0.469	11.9	2.6	66.0	3.7	94.0	3.7	94.0	3.7	94.0	4.4	111.8	4.4	111.8	4.4	111.8	5.2	132.1	6.2	157.5
44	0.500	12.7	3.1	78.7	3.7	94.0	3.7	94.0	4.4	111.8	4.4	111.8	5.2	132.1	5.2	132.1	5.2	132.1	6.2	157.5
44	0.562	14.3	3.1	78.7	4.4	111.8	4.4	111.8	5.2	132.1	5.2	132.1	5.2	132.1	5.2	132.1	6.2	157.5	7.4	188.0
44	0.625	15.9	3.7	94.0	5.2	132.1	5.2	132.1	5.2	132.1	6.2	157.5	6.2	157.5	6.2	157.5	7.4	188.0	8.8	223.5
44	0.688	17.5	4.4	111.8	5.2	132.1	5.2	132.1	6.2	157.5	6.2	157.5	7.4	188.0	7.4	188.0	7.4	188.0	8.8	223.5
44	0.750	19.1	4.4	111.8	6.2	157.5	6.2	157.5	6.2	157.5	7.4	188.0	7.4	188.0	7.4	188.0	8.8	223.5	10.5	266.7
44	0.812	20.6	5.2	132.1	6.2	157.5	7.4	188.0	7.4	188.0	7.4	188.0	8.8	223.5	8.8	223.5	8.8	223.5	10.5	266.7
44	0.875	22.2	5.2	132.1	7.4	188.0	7.4	188.0	7.4	188.0	8.8	223.5	8.8	223.5	8.8	223.5	10.5	266.7	12.6	320.0
44	0.938	23.8	6.2	157.5	7.4	188.0	8.8	223.5	8.8	223.5	8.8	223.5	10.5	266.7	10.5	266.7	10.5	266.7	12.6	320.0
44	1.000	25.4	6.2	157.5	8.8	223.5	8.8	223.5	8.8	223.5	10.5	266.7	10.5	266.7	10.5	266.7	12.6	320.0	15.1	408.9
44	1.062	27.0	7.4	188.0	8.8	223.5	8.8	223.5	10.5	266.7	10.5	266.7	12.6	320.0	12.6	320.0	12.6	320.0	15.1	383.5
44	1.125	28.6	7.4	188.0	10.5	266.7	10.5	266.7	10.5	266.7	12.6	320.0	12.6	320.0	12.6	320.0	15.1	383.5	18.1	459.7
44	1.188	30.2	7.4	188.0	10.5	266.7	10.5	266.7	12.6	320.0	12.6	320.0	12.6	320.0	15.1	383.5	15.1	383.5	18.1	459.7
44	1.250	31.8	8.8	223.5	10.5	266.7	12.6	320.0	12.6	320.0	15.1	383.5	15.1	383.5	15.1	383.5	18.1	489.7	21.7	551.2

Table G-1—Guided-bend Test Jig Dimensions (Continued)

(1)	(2)		(3)		(4)		(5)		(6)		(7)		(8)		(9)		(10)		(11)	
Size	Specified Wall Thickness <i>t</i>		Dimension A																	
			Grade																	
			A		B & X42		X46		X52		X56		X60		X65		X70		X80	
in.	mm	in.	mm	in.	mm	in.	mm	in.	mm	in.	mm	in.	mm	in.	mm	in.	mm	in.	mm	
46	0.344	8.7	1.9	48.3	2.6	66.0	2.6	66.0	2.6	66.0	3.1	78.7	3.1	78.7	3.1	78.7	3.7	94.0	4.4	111.8
46	0.375	9.5	2.2	55.9	2.6	66.0	2.6	66.0	3.1	78.7	3.1	78.7	3.7	94.0	3.7	94.0	3.7	94.0	4.4	111.8
46	0.406	10.3	2.2	55.9	3.1	78.7	3.1	78.7	3.1	78.7	3.7	94.0	3.7	94.0	3.7	94.0	4.4	111.8	5.2	132.1
46	0.438	11.1	2.6	66.0	3.1	78.7	3.1	78.7	3.7	94.0	3.7	94.0	4.4	111.8	4.4	111.8	4.4	111.8	5.2	132.1
46	0.469	11.9	2.6	66.0	3.7	94.0	3.7	94.0	3.7	94.0	4.4	111.8	4.4	111.8	4.4	111.8	5.2	132.1	6.2	157.5
46	0.500	12.7	3.1	78.7	3.7	94.0	3.7	94.0	4.4	111.8	4.4	111.8	4.4	111.8	5.2	132.1	5.2	132.1	6.2	157.5
46	0.562	14.3	3.1	78.7	4.4	111.8	4.4	111.8	4.4	111.8	5.2	132.1	5.2	132.1	5.2	132.1	6.2	157.5	7.4	188.0
46	0.625	15.9	3.7	94.0	4.4	111.8	5.2	132.1	5.2	132.1	6.2	157.5	6.2	157.5	6.2	157.5	7.4	188.0	8.8	223.5
46	0.688	17.5	4.4	111.8	5.2	132.1	5.2	132.1	6.2	157.5	6.2	157.5	7.4	188.0	7.4	188.0	7.4	188.0	8.8	223.5
46	0.750	19.1	4.4	111.8	6.2	157.5	6.2	157.5	6.2	157.5	7.4	188.0	7.4	188.0	7.4	188.0	8.8	223.5	10.5	266.7
46	0.812	20.6	5.2	132.1	6.2	157.5	6.2	157.5	7.4	188.0	7.4	188.0	8.8	223.5	8.8	223.5	8.8	223.5	10.5	266.7
46	0.875	22.2	5.2	132.1	7.4	188.0	7.4	188.0	7.4	188.0	8.8	223.5	8.8	223.5	8.8	223.5	10.5	266.7	12.6	320.0
46	0.938	23.8	6.2	157.5	7.4	188.0	7.4	188.0	8.8	223.5	8.8	223.5	10.5	266.7	10.5	266.7	10.5	266.7	12.6	320.0
46	1.000	25.4	6.2	157.5	8.8	223.5	8.8	223.5	8.8	223.5	10.5	266.7	10.5	266.7	10.5	266.7	12.6	320.0	15.1	383.5
46	1.062	27.0	7.4	188.0	8.8	223.5	8.8	223.5	10.5	266.7	10.5	266.7	12.6	320.0	12.6	320.0	12.6	320.0	15.1	383.5
46	1.125	28.6	7.4	188.0	8.8	223.5	10.5	266.7	10.5	266.7	12.6	320.0	12.6	320.0	12.6	320.0	15.1	383.5	18.1	459.7
46	1.188	30.2	7.4	188.0	10.5	266.7	10.5	266.7	12.6	320.0	12.6	320.0	12.6	320.0	15.1	383.5	15.1	383.5	18.1	459.7
46	1.250	31.8	8.8	223.5	10.5	266.7	12.6	320.0	12.6	320.0	12.6	320.0	15.1	383.5	15.1	383.5	18.1	459.7	21.7	551.2
48	0.344	8.7	1.9	48.3	2.6	66.0	2.6	66.0	2.6	66.0	3.1	78.7	3.1	78.7	3.1	78.7	3.7	94.0	4.4	111.8
48	0.375	9.5	2.2	55.9	2.6	66.0	2.6	66.0	3.1	78.7	3.1	78.7	3.7	94.0	3.7	94.0	3.7	94.0	4.4	111.8
48	0.406	10.3	2.2	55.9	3.1	78.7	3.1	78.7	3.1	78.7	3.7	94.0	3.7	94.0	3.7	94.0	4.4	111.8	5.2	132.1
48	0.438	11.1	2.6	66.0	3.1	78.7	3.1	78.7	3.7	94.0	3.7	94.0	4.4	111.8	4.4	111.8	4.4	111.8	5.2	132.1
48	0.469	11.9	2.6	66.0	3.7	94.0	3.7	94.0	3.7	94.0	4.4	111.8	4.4	111.8	4.4	111.8	5.2	132.1	6.2	157.5
48	0.500	12.7	3.1	78.7	3.7	94.0	3.7	94.0	4.4	111.8	4.4	111.8	4.4	111.8	5.2	132.1	5.2	132.1	6.2	157.5
48	0.562	14.3	3.1	78.7	4.4	111.8	4.4	111.8	4.4	111.8	5.2	132.1	5.2	132.1	5.2	132.1	6.2	157.5	7.4	188.0
48	0.625	15.9	3.7	94.0	4.4	111.8	5.2	132.1	5.2	132.1	6.2	157.5	6.2	157.5	6.2	157.5	7.4	188.0	8.8	223.5
48	0.688	17.5	4.4	111.8	5.2	132.1	5.2	132.1	6.2	157.5	6.2	157.5	7.4	188.0	7.4	188.0	7.4	188.0	8.8	223.5
48	0.750	19.1	4.4	111.8	6.2	157.5	6.2	157.5	6.2	157.5	7.4	188.0	7.4	188.0	7.4	188.0	8.8	223.5	10.5	266.7
48	0.812	20.6	5.2	132.1	6.2	157.5	6.2	157.5	7.4	188.0	7.4	188.0	8.8	223.5	8.8	223.5	8.8	223.5	10.5	266.7
48	0.875	22.2	5.2	132.1	7.4	188.0	7.4	188.0	7.4	188.0	8.8	223.5	8.8	223.5	8.8	223.5	10.5	266.7	12.6	320.0
48	0.938	23.8	6.2	157.5	7.4	188.0	7.4	188.0	8.8	223.5	8.8	223.5	10.5	266.7	10.5	266.7	10.3	266.7	12.6	320.0
48	1.000	25.4	6.2	157.5	8.8	223.5	8.8	223.5	8.8	223.5	10.5	266.7	10.5	266.7	10.5	266.7	12.6	320.0	15.1	383.5
48	1.062	27.0	6.2	157.5	8.8	223.5	8.8	223.5	10.5	266.7	10.5	266.7	12.6	320.0	12.6	320.0	12.6	320.0	15.1	383.5
48	1.125	28.6	7.4	188.0	8.8	223.5	10.5	266.7	10.5	266.7	12.6	320.0	12.6	320.0	12.6	320.0	15.1	383.5	18.1	459.7
48	1.188	30.2	7.4	188.0	10.5	266.7	10.5	266.7	12.6	320.0	12.6	320.0	12.6	320.0	12.6	320.0	15.1	383.5	18.1	459.7
48	1.250	31.8	8.8	223.5	10.5	266.7	10.5	266.7	12.6	320.0	12.6	320.0	15.1	383.5	15.1	383.5	15.1	383.5	21.7	551.2
52	0.375	9.5	2.2	55.9	2.6	60	2.6	66	3.1	78.7	3.1	78.7	3.7	94.0	3.7	94.0	3.7	94.0	4.4	111.8
52	0.406	10.3	2.2	55.9	3.1	78.7	3.1	78.7	3.1	78.7	3.7	94.0	3.7	94.0	3.7	94.0	4.4	111.8	5.2	132.1
52	0.438	11.1	2.6	66.0	3.1	78.7	3.1	78.7	3.7	94.0	3.4	94.0	4.4	111.8	4.4	111.8	4.4	111.8	5.2	132.1
52	0.469	11.9	2.6	66.0	3.7	94.0	3.7	94.0	3.7	94.0	4.4	111.8	4.4	111.8	4.4	111.8	5.2	132.1	6.2	157.5
52	0.500	12.7	3.1	78.7	3.7	94.0	3.7	94.0	4.4	111.8	4.4	111.8	4.4	111.8	5.2	132.1	5.2	132.1	6.2	157.5
52	0.562	14.3	3.1	78.7	4.4	111.8	4.4	111.8	4.4	111.8	5.2	132.1	5.2	132.1	5.2	132.1	6.2	157.5	7.4	188.0
52	0.625	15.9	3.7	94.0	4.4	111.8	5.2	132.1	5.2	132.1	6.2	157.5	6.2	157.5	6.2	157.5	6.2	157.5	7.4	188.0
52	0.688	17.5	4.4	111.8	5.2	132.1	5.2	132.1	6.2	157.5	6.2	157.5	6.2	157.5	7.4	188.0	7.4	188.0	8.8	223.5
52	0.750	19.1	4.4	111.8	6.2	157.5	6.2	157.5	6.2	157.5	7.4	188.0	7.4	188.0	7.4	188.0	8.8	223.5	10.5	266.7
52	0.812	20.6	5.2	132.1	6.2	157.5	6.2	157.5	7.4	188.0	7.4	188.0	8.8	223.5	8.8	223.5	8.8	223.5	10.5	266.7
52	0.875	22.2	5.2	132.1	7.4	188.0	7.4	188.0	7.4	188.0	8.8	223.5	8.8	223.5	8.8	223.5	10.5	266.7	12.6	320.0
52	0.938	23.8	6.2	157.5	7.4	188.0	7.4	188.0	8.8	223.5	8.8	223.5	10.5	266.7	10.5	266.7	10.5	266.7	12.6	320.0
52	1.000	25.4	6.2	157.5	7.4	188.0	8.8	223.5	8.8	223.5	10.5	266.7	10.5	266.7	10.5	266.7	12.6	320.0	15.1	383.5
52	1.062	27.0	6.2	157.5	8.8	223.5	8.8	223.5	10.5	266.7	10.5	266.7	12.6	320.0	12.6	320.0	12.6	320.0	15.1	383.5
52	1.125	28.6	7.4	188.0	8.8	223.5	10.5	266.7	10.5	266.7	10.5	266.7	12.6	320.0	12.6	320.0	12.6	320.0	18.1	459.7

Table G-1—Guided-bend Test Jig Dimensions (Continued)

(1)	(2) Specified Wall Thickness <i>t</i>		(3)–(11) Dimension A Grade																	
			(4) A		(5) B & X42		(6) X46		(7) X52		(8) X56		(9) X60		(10) X65		(11) X70		(12) X80	
			in.	mm	in.	mm	in.	mm	in.	mm	in.	mm	in.	mm	in.	mm	in.	mm	in.	mm
52	1.188	30.2	7.4	188.0	10.5	266.7	10.5	266.7	10.5	266.7	12.6	320.0	12.6	320.0	12.6	320.0	15.1	383.5	18.1	459.7
52	1.250	31.8	8.8	223.6	10.5	266.7	10.5	266.7	12.6	320.0	12.6	320.0	15.1	383.5	15.1	383.5	15.1	383.5	18.1	459.7
56	0.375	9.5	2.2	55.9	2.6	66.0	2.6	66.0	3.1	78.7	3.1	78.7	3.7	94.0	3.7	94.0	3.7	94.0	4.4	111.8
56	0.406	10.3	2.2	55.9	3.1	78.7	3.1	78.7	3.1	78.7	3.7	94.0	3.7	94.0	3.7	94.0	4.4	111.8	5.2	132.1
56	0.438	11.1	2.6	66.0	3.1	78.7	3.1	78.7	3.7	94.0	3.7	94.0	3.7	94.0	4.4	111.8	4.4	111.8	5.2	132.1
56	0.469	11.9	2.6	66.0	3.7	94.0	3.7	94.0	3.7	94.0	4.4	111.8	4.4	111.8	4.4	111.8	5.2	132.1	6.2	157.5
56	0.500	12.7	3.1	78.7	3.7	94.0	3.7	94.0	4.4	111.8	4.4	111.8	4.4	111.8	4.4	111.8	5.2	132.1	6.2	157.5
56	0.562	14.3	3.1	78.7	4.4	111.8	4.4	111.8	4.4	111.8	5.2	132.1	5.2	132.1	5.2	132.1	6.2	157.5	7.4	188.0
56	0.625	15.9	3.7	94.0	4.4	111.8	5.2	132.1	5.2	132.1	5.2	132.1	6.2	157.5	6.2	157.5	6.2	157.5	7.4	188.0
56	0.688	17.5	4.4	111.8	5.2	132.1	5.2	132.1	6.2	157.5	6.2	157.5	6.2	157.5	7.4	188.0	7.4	188.0	8.8	223.5
56	0.750	19.1	4.4	111.8	6.2	157.5	6.2	157.5	6.2	157.5	7.4	188.0	7.4	188.0	7.4	188.0	8.8	223.5	10.5	266.7
56	0.812	20.6	5.2	132.1	6.2	157.5	6.2	157.5	7.4	188.0	7.4	188.0	7.4	188.0	8.8	223.5	8.8	223.5	10.5	266.7
56	0.875	22.2	5.2	132.1	7.4	188.0	7.4	188.0	7.4	188.0	8.8	223.5	8.8	223.5	8.8	223.5	10.5	266.7	12.6	320.0
56	0.938	23.8	6.2	157.5	7.4	188.0	7.4	188.0	8.8	223.5	8.8	223.5	8.8	223.5	10.5	266.7	10.5	266.7	12.6	320.0
56	1.000	25.4	6.2	157.5	7.4	188.0	8.8	223.5	8.8	223.5	10.5	266.7	10.5	266.7	10.5	266.7	12.6	320.0	15.1	383.5
56	1.062	27.0	6.2	157.5	8.8	223.5	8.8	223.5	10.5	266.7	10.5	266.7	10.5	266.7	10.5	266.7	12.6	320.0	15.1	383.5
56	1.125	28.6	7.4	188.0	8.8	223.5	8.8	223.5	10.5	266.7	10.5	266.7	12.6	320.0	12.6	320.0	12.6	320.0	15.1	383.5
56	1.188	30.2	7.4	188.0	10.5	266.7	10.5	266.7	10.5	266.7	12.6	320.0	12.6	320.0	12.6	320.0	15.1	383.5	18.1	459.7
56	1.250	31.8	7.4	188.0	10.5	266.7	10.5	266.7	12.6	320.0	12.6	320.0	12.6	320.0	15.1	383.5	15.1	383.5	18.1	459.7
60	0.375	9.5	2.2	55.9	2.6	66.0	2.6	66.0	3.1	78.7	3.1	78.7	3.1	78.7	3.7	94.0	3.7	94.0	4.4	111.8
60	0.406	10.3	2.2	55.9	3.1	78.7	3.1	78.7	3.1	78.7	3.7	94.0	3.7	94.0	3.7	94.0	4.4	111.8	5.2	132.1
60	0.438	11.1	2.6	66.0	3.1	78.7	3.1	78.7	3.7	94.0	3.7	94.0	3.7	94.0	4.4	111.8	4.4	111.8	5.2	132.1
60	0.469	11.9	2.6	66.0	3.1	78.7	3.7	94.0	3.7	94.0	4.4	111.8	4.4	111.8	4.4	111.8	5.2	132.1	5.2	132.1
60	0.500	12.7	3.1	78.7	3.7	94.0	3.7	94.0	4.4	111.8	4.4	111.8	4.4	111.8	4.4	111.8	5.2	132.1	6.2	157.5
60	0.562	14.3	3.1	78.7	4.4	111.8	4.4	111.8	4.4	111.8	5.2	132.1	5.2	132.1	5.2	132.1	6.2	157.5	7.4	188.0
60	0.625	15.9	3.7	94.0	4.4	111.8	5.2	132.1	5.2	132.1	5.2	132.1	6.2	157.5	6.2	157.5	6.2	157.5	7.4	188.0
60	0.688	17.5	3.7	94.0	5.2	132.1	5.2	132.1	6.2	157.5	6.2	157.5	6.2	157.5	7.4	188.0	7.4	188.0	8.8	223.5
60	0.750	19.1	4.4	111.8	5.2	132.1	6.2	157.5	6.2	157.5	7.4	188.0	7.4	188.0	7.4	188.0	8.8	223.5	8.8	223.5
60	0.812	20.6	5.2	132.1	6.2	157.5	6.2	157.5	7.4	188.0	7.4	188.0	7.4	188.0	8.8	223.5	8.8	223.5	10.5	266.7
60	0.875	22.2	5.2	132.1	6.2	157.5	7.4	188.0	7.4	188.0	8.8	223.5	8.8	223.5	8.8	223.5	10.5	266.7	10.5	266.7
60	0.938	23.8	5.2	132.1	7.4	188.0	7.4	188.0	8.8	223.5	8.8	223.5	8.8	223.5	10.5	266.7	10.5	266.7	12.6	320.0
60	1.000	25.4	6.2	157.5	7.4	188.0	8.8	223.5	8.8	223.5	8.8	223.5	10.5	266.7	10.5	266.7	10.5	266.7	12.6	320.0
60	1.062	27.0	6.2	157.5	8.8	223.5	8.8	223.5	8.8	223.5	10.5	266.7	10.5	266.7	10.5	266.7	12.6	320.0	15.1	383.5
60	1.125	28.6	7.4	188.0	8.8	223.5	8.8	223.5	10.5	266.7	10.5	266.7	12.6	320.0	12.6	320.0	12.6	320.0	15.1	383.5
60	1.188	30.2	7.4	188.0	10.5	266.7	10.5	266.7	10.5	266.7	12.6	320.0	12.6	320.0	12.6	320.0	15.1	383.5	18.1	459.7
60	1.250	31.8	7.4	188.0	10.5	266.7	10.5	266.7	12.6	320.0	12.6	320.0	12.6	320.0	12.6	320.0	15.1	383.5	18.1	459.7
64	0.375	9.5	2.2	55.9	2.6	66.0	2.6	66.0	3.1	78.7	3.1	78.7	3.1	78.7	3.7	94.0	3.7	94.0	4.4	111.8
64	0.406	10.3	2.2	55.9	3.1	78.7	3.1	78.7	3.1	78.7	3.7	94.0	3.7	94.0	3.7	94.0	4.4	111.8	5.2	132.1
64	0.438	11.1	2.6	66.0	3.1	78.7	3.1	78.7	3.7	94.0	3.7	94.0	3.7	94.0	4.4	111.8	4.4	111.8	5.2	132.1
64	0.469	11.9	2.6	66.0	3.1	78.7	3.7	94.0	3.7	94.0	4.4	111.8	4.4	111.8	4.4	111.8	5.2	132.1	5.2	132.1
64	0.500	12.7	3.1	78.7	3.7	94.0	3.7	94.0	4.4	111.8	4.4	111.8	4.4	111.8	4.4	111.8	5.2	132.1	6.2	157.5
64	0.562	14.3	3.1	78.7	4.4	111.8	4.4	111.8	4.4	111.8	5.2	132.1	5.2	132.1	5.2	132.1	6.2	157.5	7.4	188.0
64	0.625	15.9	3.7	94.0	4.4	111.8	5.2	132.1	5.2	132.1	6.2	157.5	6.2	157.5	6.2	157.5	7.4	188.0	7.4	188.0
64	0.688	17.5	3.7	94.0	5.2	132.1	5.2	132.1	6.2	157.5	6.2	157.5	6.2	157.5	7.4	188.0	7.4	188.0	8.8	223.5
64	0.750	19.1	4.4	111.8	5.2	132.1	6.2	157.5	6.2	157.5	7.4	188.0	7.4	188.0	7.4	188.0	8.8	223.5	8.8	223.5
64	0.812	20.6	5.2	132.1	6.2	157.5	6.2	157.5	7.4	188.0	7.4	188.0	7.4	188.0	8.8	223.5	8.8	223.5	10.5	266.7
64	0.875	22.2	5.2	132.1	6.2	157.5	7.4	188.0	7.4	188.0	8.8	223.5	8.8	223.5	8.8	223.5	10.5	266.7	10.5	266.7
64	0.938	23.8	5.2	132.1	7.4	188.0	7.4	188.0	8.8	223.5	8.8	223.5	8.8	223.5	10.5	266.7	10.5	266.7	12.6	320.0
64	1.000	25.4	6.2	157.5	7.4	188.0	8.8	223.5	8.8	223.5	8.8	223.5	10.5	266.7	10.5	266.7	10.5	266.7	12.6	320.0
64	1.062	27.0	6.2	157.5	8.8	223.5	8.8	223.5	8.8	223.5	10.5	266.7	10.5	266.7	10.5	266.7	12.6	320.0	15.1	383.5

Table G-1—Guided-bend Test Jig Dimensions (Continued)

(1)	(2)		(3)		(4)		(5)		(6)		(7)		(8)		(9)		(10)		(11)																		
																					Specified Wall Thickness <i>t</i>	Dimension A															
																						Grade															
																						A		B & X42		X46		X52		X56		X60		X65		X70	
Size	in.	mm	in.	mm	in.	mm	in.	mm	in.	mm	in.	mm	in.	mm	in.	mm	in.	mm	in.	mm																	
64	1.125	28.6	7.4	188.0	8.8	223.5	8.8	223.5	10.5	266.7	10.5	266.7	10.5	266.7	12.6	320.0	12.6	320.0	15.1	383.5																	
64	1.188	30.2	7.4	188.0	8.8	223.5	10.5	266.7	10.5	266.7	12.6	320.0	12.6	320.0	12.6	320.0	15.1	383.5	18.1	459.7																	
64	1.250	31.8	7.4	188.0	10.5	266.7	10.5	266.7	10.5	266.7	12.6	320.0	12.6	320.0	12.6	320.0	15.1	383.5	18.1	459.7																	
68	0.469	11.9	2.6	66.0	3.1	78.7	3.7	94.0	3.7	94.0	4.4	111.8	4.4	111.8	4.4	111.8	4.4	111.8	5.2	132.1																	
68	0.500	12.7	2.6	66.0	3.7	94.0	3.7	94.0	3.7	94.0	4.4	111.8	4.4	111.8	4.4	111.8	5.2	132.1	6.2	157.5																	
68	0.562	14.3	3.1	78.7	4.4	111.8	4.4	111.8	4.4	111.8	5.2	132.1	5.2	132.1	5.2	132.1	6.2	157.5	7.4	188.0																	
68	0.625	15.9	3.7	94.0	4.4	111.8	5.2	132.1	5.2	132.1	5.2	132.1	6.2	157.5	6.2	157.5	6.2	157.5	7.4	188.0																	
68	0.688	17.5	3.7	94.0	5.2	132.1	5.2	132.1	6.2	157.5	6.2	157.5	6.2	157.5	7.4	188.0	7.4	188.0	8.8	223.5																	
68	0.750	19.1	4.4	111.8	5.2	132.1	6.2	157.5	6.2	157.5	6.2	157.5	7.4	188.0	7.4	188.0	7.4	188.0	8.8	223.5																	
68	0.812	20.6	5.2	132.1	6.2	157.5	6.2	157.5	7.4	188.0	7.4	188.0	7.4	188.0	7.4	188.0	8.8	223.5	10.5	266.7																	
68	0.875	22.2	5.2	132.1	6.2	157.5	7.4	188.0	7.4	188.0	7.4	188.0	8.8	223.5	8.8	223.5	8.8	223.5	10.5	266.7																	
68	0.938	23.8	5.2	132.1	7.4	188.0	7.4	188.0	7.4	188.0	8.8	223.5	8.8	223.5	8.8	223.5	10.5	266.7	12.6	320.0																	
68	1.000	25.4	6.2	157.5	7.4	188.0	7.4	188.0	8.8	223.5	8.8	223.5	10.5	266.7	10.5	266.7	10.5	266.7	12.6	320.0																	
68	1.062	27.0	6.2	157.5	8.8	223.5	8.8	223.5	8.8	223.5	10.5	266.7	10.5	266.7	10.5	266.7	12.6	320.0	15.1	383.5																	
68	1.125	28.6	7.4	188.0	8.8	223.5	8.8	223.5	10.5	266.7	10.5	266.7	10.5	266.7	12.6	320.0	12.6	320.0	15.1	383.5																	
68	1.188	30.2	7.4	188.0	8.8	223.5	10.5	266.7	10.5	266.7	10.5	266.7	12.6	320.0	12.6	320.0	12.6	320.0	15.1	383.5																	
68	1.250	31.8	7.4	188.0	10.5	266.7	10.5	266.7	10.5	266.7	12.6	320.0	12.6	320.0	12.6	320.0	15.1	383.5	18.1	459.7																	
72	0.500	12.7	2.6	66.0	3.7	94.0	3.7	94.0	3.7	94.0	4.4	111.8	4.4	111.8	4.4	111.8	5.2	132.1	6.2	157.5																	
72	0.562	14.3	3.1	78.7	4.4	111.8	4.4	111.8	4.4	111.8	5.2	132.1	5.2	132.1	5.2	132.1	6.2	157.5	6.2	157.5																	
72	0.625	15.9	3.7	94.0	4.4	111.8	4.4	111.8	5.2	132.1	5.2	132.1	6.2	157.5	6.2	157.5	6.2	157.5	7.4	188.0																	
72	0.688	17.5	3.7	94.0	5.2	132.1	5.2	132.1	5.2	132.1	6.2	157.5	6.2	157.5	6.2	157.5	7.4	188.0	8.8	223.5																	
72	0.750	19.1	4.4	111.8	5.2	132.1	6.2	157.5	6.2	157.5	6.2	157.5	7.4	188.0	7.4	188.0	7.4	188.0	8.8	223.5																	
72	0.812	20.6	4.4	111.8	6.2	157.5	6.2	157.5	7.4	188.0	7.4	188.0	7.4	188.0	7.4	188.0	8.8	223.5	10.5	266.7																	
72	0.875	22.2	5.2	132.1	6.2	157.5	7.4	188.0	7.4	188.0	7.4	188.0	8.8	223.5	8.8	223.5	8.8	223.5	10.5	266.7																	
72	0.938	23.8	5.2	132.1	7.4	188.0	7.4	188.0	7.4	188.0	8.8	223.5	8.8	223.5	8.8	223.5	10.5	266.7	12.6	320.0																	
72	1.000	25.4	6.2	157.5	7.4	188.0	7.4	188.0	8.8	223.5	8.8	223.5	10.5	266.7	10.5	266.7	10.5	266.7	12.6	320.0																	
72	1.062	27.0	6.2	157.5	8.8	223.5	8.8	223.5	8.8	223.5	10.5	266.7	10.5	266.7	10.5	266.7	12.6	320.0	15.1	383.5																	
72	1.125	28.6	7.4	188.0	8.8	223.5	8.8	223.5	10.5	266.7	10.5	266.7	10.5	266.7	12.6	320.0	12.6	320.0	15.1	383.5																	
72	1.188	30.2	7.4	188.0	8.8	223.5	10.5	266.7	10.5	266.7	10.5	266.7	12.6	320.0	12.6	320.0	12.6	320.0	15.1	383.5																	
72	1.250	31.8	7.4	188.0	10.5	266.7	10.5	266.7	10.5	266.7	12.6	320.0	12.6	320.0	12.6	320.0	15.1	383.5	18.1	459.7																	
76	0.500	12.7	2.6	66.0	3.7	94.0	3.7	94.0	3.7	94.0	4.4	111.8	4.4	111.8	4.4	111.8	5.2	132.1	6.2	157.5																	
76	0.562	14.3	3.1	78.7	4.4	111.8	4.4	111.8	4.4	111.8	5.2	132.1	5.2	132.1	5.2	132.1	6.2	157.5	6.2	157.5																	
76	0.625	15.9	3.7	94.0	4.4	111.8	4.4	111.8	5.2	132.1	5.2	132.1	6.2	157.5	6.2	157.5	6.2	157.5	7.4	188.0																	
76	0.688	17.5	3.7	94.0	5.2	132.1	5.2	132.1	5.2	132.1	6.2	157.5	6.2	157.5	6.2	157.5	7.4	188.0	8.8	223.5																	
76	0.750	19.1	4.4	111.8	5.2	132.1	6.2	157.5	6.2	157.5	6.2	157.5	7.4	188.0	7.4	188.0	7.4	188.0	8.8	223.5																	
76	0.812	20.6	4.4	111.8	6.2	157.5	6.2	157.5	6.2	157.5	7.4	188.0	7.4	188.0	7.4	188.0	8.8	223.5	10.5	266.7																	
76	0.875	22.2	5.2	132.1	6.2	157.5	7.4	188.0	7.4	188.0	7.4	188.0	8.8	223.5	8.8	223.5	8.8	223.5	10.5	266.7																	
76	0.938	23.8	5.2	132.1	7.4	188.0	7.4	188.0	7.4	188.0	8.8	223.5	8.8	223.5	8.8	223.5	10.5	266.7	12.6	320.0																	
76	1.000	25.4	6.2	157.5	7.4	188.0	7.4	188.0	8.8	223.5	8.8	223.5	10.5	266.7	10.5	266.7	10.5	266.7	12.6	320.0																	
76	1.062	27.0	6.2	157.5	8.8	223.5	8.8	223.5	8.8	223.5	10.5	266.7	10.5	266.7	10.5	266.7	12.6	320.0	15.1	383.5																	
76	1.125	28.6	7.4	188.0	8.8	223.5	8.8	223.5	10.5	266.7	10.5	266.7	10.5	266.7	12.6	320.0	12.6	320.0	15.1	383.5																	
76	1.188	30.2	7.4	188.0	8.8	223.5	10.5	266.7	10.5	266.7	10.5	266.7	12.6	320.0	12.6	320.0	12.6	320.0	15.1	383.5																	
76	1.250	31.8	7.4	188.0	10.5	266.7	10.5	266.7	10.5	266.7	12.6	320.0	12.6	320.0	12.6	320.0	15.1	383.5	18.1	459.7																	
80	0.562	14.3	3.1	78.7	3.7	94.0	4.4	111.8	4.4	111.8	5.2	132.1	5.2	132.1	5.2	132.1	6.2	157.5	6.6	167.6																	
80	0.625	15.9	3.7	94.0	4.4	111.8	4.4	111.8	5.2	132.1	5.2	132.1	6.2	157.5	6.2	157.5	6.2	157.5	7.4	188.0																	

Table G-1—Guided-bend Test Jig Dimensions (Continued)

(1)	(2)		(3)		(4)		(5)		(6)		(7)		(8)		(9)		(10)		(11)																			
																					Specified Wall Thickness <i>t</i>		Dimension A															
																							Grade															
																							A		B & X42		X46		X52		X56		X60		X65		X70	
in.	mm	in.	mm	in.	mm	in.	mm	in.	mm	in.	mm	in.	mm	in.	mm	in.	mm	in.	mm																			
80	0.688	17.5	3.7	94.0	5.2	132.1	5.2	132.1	5.2	132.1	6.2	157.5	6.2	157.5	6.2	157.5	7.4	188.0	8.8	223.5																		
80	0.750	19.1	4.4	111.8	5.2	132.1	6.2	157.5	6.2	157.5	6.2	157.5	7.4	188.0	7.4	188.0	7.4	188.0	8.8	223.5																		
80	0.812	20.6	4.4	111.8	6.2	157.5	6.2	157.5	6.2	157.5	7.4	188.0	7.4	188.0	7.4	188.0	8.8	223.5	10.5	266.7																		
80	0.875	22.2	5.2	132.1	6.2	157.5	7.4	188.0	7.4	188.0	7.4	188.0	8.8	223.5	8.8	223.5	8.8	223.5	10.5	266.7																		
80	0.938	23.8	5.2	132.1	7.4	188.0	7.4	188.0	7.4	188.0	8.8	223.5	8.8	223.5	8.8	223.5	10.5	266.7	12.6	320.0																		
80	1.000	25.4	6.2	157.5	7.4	188.0	7.4	188.0	8.8	223.5	8.8	223.5	10.5	266.7	10.5	266.7	10.5	266.7	12.6	320.0																		
80	1.062	27.0	6.2	157.5	7.4	188.0	8.8	223.5	8.8	223.5	10.5	266.7	10.5	266.7	10.5	266.7	12.6	320.0	12.6	320.0																		
80	1.125	28.6	6.2	157.5	8.8	223.5	8.8	223.5	10.5	266.7	10.5	266.7	10.5	266.7	10.5	266.7	12.6	320.0	15.1	383.5																		
80	1.188	30.2	7.4	188.0	8.8	223.5	8.8	223.5	10.5	266.7	10.5	266.7	12.6	320.0	12.6	320.0	12.6	320.0	15.1	383.5																		
80	1.250	31.8	7.4	188.0	10.5	266.7	10.5	266.7	10.5	266.7	12.6	320.0	12.6	320.0	12.6	320.0	15.1	383.5	18.1	459.7																		

APPENDIX H—PURCHASER INSPECTION (NORMATIVE)

H.1 Inspection Notice

Where the inspector representing the purchaser desires to inspect pipe or witness tests, reasonable notice shall be given of the time at which the run is to be made.

H.2 Plant Access

The inspector representing the purchaser shall have unrestricted access, at all times while work on the contract of the purchaser is being performed, to all parts of the manufacturer's works that will concern the manufacture of the pipe ordered. The manufacturer shall afford the inspector all reasonable facilities to satisfy the inspector that the pipe is being manufactured in accordance with this specification. All inspections should be made at the place of manufacture prior to shipment, unless otherwise specified on the purchase order, and shall be so conducted as not to interfere unnecessarily with the operation of the works.

H.3 Compliance

The manufacturer is responsible for complying with all of the provisions of this specification. The purchaser may make any investigation necessary to be satisfied of compliance by the manufacturer and may reject any material that does not comply with this specification.

H.4 Rejection

Unless otherwise provided, material that shows defects on inspection or subsequent to acceptance at the manufacturer's works, or material that proves defective when properly applied in service, may be rejected and the manufacturer so notified. If tests that require the destruction of material are made, any product proven not to have met the requirements of the specification shall be rejected. Disposition of rejected product shall be a matter of agreement between the manufacturer and the purchaser.

APPENDIX I—MARKING INSTRUCTIONS FOR API LICENSEES (NORMATIVE)

I.1 General

The marking requirements in this appendix apply to licensed manufacturers using the API monogram on products covered by this specification.

Pipe and pipe couplings manufactured in conformance with this specification may be marked by the licensee as specified in Appendix I or Section 10. Products to which the monogram is applied shall be marked as specified in Appendix I.

I.1.1 The required marking on pipe shall be as stipulated hereinafter.

I.1.2 The required marking on couplings shall be die stamped unless otherwise agreed between the purchaser and the manufacturer, in which case they shall be paint stenciled.

I.1.3 Additional markings, including those for compatible standards following the specification marking, are allowed and may be applied as desired by the manufacturer or as requested by the purchaser.

I.2 Location of Markings

The location of identification markings shall be as specified in I.2.1 – I.2.3.

I.2.1 SIZES 1.900 AND SMALLER

The marking is die stamped on a metal tag fixed to the bundle, or may be printed on the straps or banding clips used to tie the bundle.

I.2.2 SEAMLESS PIPE IN ALL OTHER SIZES AND WELDED PIPE SMALLER THAN SIZE 16

Paint stencil on the outside surface starting at a point between 18 in. and 30 in. (460 and 760 mm) from the end of the pipe, and in the sequence shown in I.3, except when agreed between the purchaser and the manufacturer, some or all of the markings may be placed on the inside surface in a sequence convenient to the manufacturer.

I.2.3 WELDED PIPE SIZES 16 AND LARGER

Paint stencil on the inside surface starting at a point no less than 6 in. from the end of the pipe in a sequence convenient to the manufacturer, unless otherwise specified by the purchaser.

I.3 Sequence of Markings

The sequence of identification markings shall be as specified in I.3.1 – I.3.10.

I.3.1 MANUFACTURER'S API LICENSE NUMBER

The manufacturer's API license number shall be marked. (The manufacturer's name or mark is optional.)

I.3.2 API MONOGRAM () AND DATE

The API monogram () immediately followed by the date of manufacture (defined as the month and year when the monogram is applied), shall be applied only to products complying with the requirements of the specification and only by authorized manufacturers.

I.3.3 COMPATIBLE STANDARDS

Products in compliance with multiple compatible standards may be marked with the name of each standard.

I.3.4 SPECIFIED DIMENSIONS

The specified outside diameter and the specified wall thickness shall be marked, except that, for the specified outside diameter, any ending zero digits to the right of the decimal need not be included in such markings.

I.3.5 GRADE AND CLASS

The symbols to be used are as follows:

Grade (see Note)	Symbol
Grade A25-Class I	A25
Grade A25-Class II	A25R
Grade A	A
Grade B	B
Grade X42	X42
Grade X46	X46
Grade X52	X52
Grade X56	X56
Grade X60	X60
Grade X65	X65
Grade X70	X70
Grade X80	X80

Note: See I.3 for limitations on downgrading.

For grades intermediate to X42 and X80, the symbol shall be X followed by the first two digits of the specified minimum yield strength in U.S. Customary units.

By agreement between the purchaser and the manufacturer and when so specified on the purchase order, the grade shall be identified by color in accordance with SR3.

I.3.6 PRODUCT SPECIFICATION LEVEL

The symbols to be used are as follows:

- | | |
|----------|------|
| a. PSL 1 | PSL1 |
| b. PSL 2 | PSL2 |

The PSL marking shall be placed immediately after the grade symbol.

I.3.7 PROCESS OF MANUFACTURE

The symbols to be used are as follows:

- | | |
|-----------------------------------------------------------|---|
| a. Seamless pipe | S |
| b. Welded pipe, except continuous welded and laser welded | E |
| c. Continuous welded pipe | F |
| d. Laser welded pipe | L |

I.3.8 HEAT TREATMENT

The symbols to be used are as follows:

- | | |
|------------------------------------------|----|
| a. Normalized or normalized and tempered | HN |
| b. Subcritical stress relieved | HS |
| c. Subcritical age hardened | HA |
| d. Quench and Tempered | HQ |

I.3.9 TEST PRESSURE

When the specified hydrostatic test pressure is higher than the tabulated standard pressure (Tables 4, 5, 6A, 6B, 6C, E-6A, E-6B, or E-6C, whichever is applicable), the word "TESTED" shall be marked, immediately followed by the specified test pressure (in pounds per square inch for pipe ordered in U.S. Customary units, or in hundreds of kilopascals for pipe ordered in SI units).

I.3.10 SUPPLEMENTARY REQUIREMENTS

See Appendix F for supplementary requirements.

I.3.11 EXAMPLES

a. Size 14, 0.375 in. (9.5 mm) specified wall thickness, Grade B, PSL 2, seamless, plain-end pipe should be paint stenciled as follows, using the values that are appropriate for the pipe dimensions specified on the purchase order:

5LXXXX.X Φ (MO-YR) 14 0.375 B PSL2 S
or

5LXXXX.X Φ (MO-YR) 355.6 9.5 B PSL2 S

b. Size 6⁵/₈, 0.280 in. (7.1 mm) specified wall thickness, Grade B, PSL 1, electric welded, plain-end pipe should be

paint stenciled as follows, using the values that are appropriate for the pipe dimensions specified on the purchase order:

5LXXXX.X Φ (MO-YR) 6.625 0.280 B PSL1 E
or
5LXXXX.X Φ (MO-YR) 168.3 7.1 B PSL1 E

c. Size 4¹/₂, 0.237 in. (6.0 mm) specified wall thickness, Grade A25, Class I, continuous welded, threaded-end pipe should be paint stenciled as follows, using the values that are appropriate for the pipe dimensions specified on the purchase order:

5LXXXX.X Φ (MO-YR) 4.5 0.237 A25 PSL1 F
or
5LXXXX.X Φ (MO-YR) 114.3 6.0 A25 PSL1 F

d. Size 14, 0.375 in. (9.5 mm) specified wall thickness, Grade X70, PSL 2, seamless, quenched and tempered, plain-end pipe should be paint stenciled as follows, using the values that are appropriate for the pipe dimensions specified on the purchase order:

5LXXXX.X Φ (MO-YR) 14 0.375 X70
PSL2 S HQ
or
5LXXXX.X Φ (MO-YR) 355.6 9.5 X70
PSL2 S HQ

e. Size 12³/₄, 0.330 in. (8.4 mm) specified wall thickness, Grade X42, PSL 1, seamless plain-end pipe should be paint stenciled as follows, using the values that are appropriate for the pipe dimensions specified on the purchase order:

5LXXXX.X Φ (MO-YR) 12.75 0.330 X42
PSL1 S
or
5LXXXX.X Φ (MO-YR) 323.9 8.4 X42
PSL1 S

f. Size 6⁵/₈, 0.216 in. (5.5 mm) specified wall thickness, Grade X42, PSL 1, laser welded, plain-end pipe should be paint stenciled as follows, using the values that are appropriate for the pipe dimensions specified on the purchase order:

5LXXXX.X Φ (MO-YR) 6.625 0.216 X42
PSL1 L
or
5LXXXX.X Φ (MO-YR) 168.3 5.5 X42
PSL1 L

g. Size 24, 0.406 in. (10.3 mm) specified wall thickness, Grade X42, PSL 2 helical seam submerged-arc welded plain-end pipe should be paint stenciled as follows, using the values that are appropriate for the pipe dimensions specified on the purchase order:

5LXXXX.X \diamond (MO-YR) 24 0.406 X42 PSL2 E
 or
 5LXXXX.X \diamond (MO-YR) 610 10.3 X42 PSL2 E

I.4 Bundle Identification

For pipe of size 1.900 or smaller, the identification markings specified in I.3 shall be placed on the tag, strap, or clip used to tie the bundle. For example, size 1.900, 0.145 in. (3.7 mm) specified wall thickness, Grade B, electric welded, plain-end pipe should be marked as follows, using the values that are appropriate for the pipe dimensions specified on the purchase order:

5LXXXX.X \diamond (MO-YR) 1.9 0.145 B PSL1 E
 or
 5LXXXX.X \diamond (MO-YR) 48.3 3.7 B PSL1 E

I.5 Length

In addition to the identification markings stipulated in I.2, I.3, and I.4, the length shall be marked as follows, using feet and tenths of a foot for pipe ordered in U.S. Customary units, or meters to two decimal places for pipe ordered in SI units, unless a different measuring and marking format has been agreed upon by the purchaser and manufacturer:

- For pipe larger than size 1.900, the length, as measured on the finished pipe, shall be paint stenciled on the outside surface at a location convenient to the manufacturer, or by agreement between the purchaser and the manufacturer, on the inside surface at a convenient location.
- For pipe of size 1.900 or smaller, the total length of pipe in the bundle shall be marked on the tag, band, or clip.

I.6 Couplings

All couplings in sizes $2\frac{3}{8}$ and larger shall be identified with the manufacturer's name or mark and the API monogram (\diamond), immediately followed by the date of manufacture (defined as the month and year when the monogram is applied).

I.7 Die Stamping

Cold die stamping of grades higher than A25 plate or pipe not subsequently heat treated and all pipe with wall thickness

of 0.156 in. (4.0 mm) and less is prohibited, except that by agreement between the purchaser and the manufacturer and when so specified on the purchase order, pipe or plate may be cold die stamped. The manufacturer at his option may hot die stamp [200°F (93°C) or higher] plate or pipe, cold die stamp plate or pipe if it is subsequently heat treated, and cold die stamp couplings. Cold die stamping shall be done with rounded or blunt dies. All die stamping shall be at least 1 in. (25 mm) from the weld for all grades except Grade A25.

I.8 Thread Identification

At the manufacturer's option, threaded-end pipe may be identified by stamping or stenciling the pipe adjacent to the threaded ends, with the threader's API license number, the API monogram (\diamond), immediately followed by the date of threading (defined as the month and year the monogram is applied), the specified outside diameter of the pipe, and LP to indicate the type of thread. The thread marking may be applied to products that do or do not bear the API monogram. For example, size $6\frac{5}{8}$ threaded-end pipe may be marked as follows, using the value that is appropriate for the pipe outside diameter specified on the purchase order:

5LXXXX.X \diamond (MO-YR of threading) 6.625 LP
 or
 5LXXXX.X \diamond (MO-YR of threading) 168.3 LP

If the product is clearly marked elsewhere with the manufacturer's identification, his license number, as above, may be omitted.

I.9 Thread Certification

The use of the monogram (\diamond) as provided in I.8 shall constitute a certification by the manufacturer that the threads so marked comply with the requirements stipulated in the latest edition of API Std 5B but should not be construed by the purchaser as a representation that the product so marked is, in its entirety, in accordance with any API specification. Manufacturers who use the monogram (\diamond) for thread identification are required to have access to properly certified API reference master pipe gages.

I.10 Pipe Processor Markings

Pipe heat treated by a processor other than the original pipe manufacturer shall be marked as stipulated in I.1 – I.7. The processor shall remove any identification that is not indicative of a new condition of the product as a result of heat treating (such as, prior grade and original pipe manufacturer's name or logo).

APPENDIX J— SUMMARY OF DIFFERENCES BETWEEN PSL 1 AND PSL 2 (INFORMATIVE)

Parameter	PSL 1	PSL 2	Reference
Grade range	A25 through X70	B through X80	Table 1
Size range	0.405 through 80	4 1/2 through 80	Table 1
Type of Pipe Ends	Plain-end, threaded-end; belled-end; special coupling pipe	Plain-end	Table 1
Seam welding	All methods; continuous welding limited to Grade A25	All methods except continuous and laser welding	Table 1
Electric welds: welder frequency	No minimum	100 kHz minimum	5.1.3.3.2
Heat treatment of electric welds	Required for grades > X42	Required for all grades (B through X80)	5.1.3.3.1; 5.1.3.3.2; 6.2.6
Chemistry: max C for seamless pipe	0.28% for grades ≥ B	0.24%	Tables 2A, 2B
Chemistry: max C for welded pipe	0.26% for grades ≥ B	0.22%	Tables 2A, 2B
Chemistry: max P	0.030% for grades ≥ A	0.025%	Tables 2A, 2B
Chemistry: max S	0.030%	0.015%	Tables 2A, 2B
Carbon Equivalent:	Only when purchaser specifies SR18	Maximum required for each grade	4.2; 4.3; 6.1.3; SR15.1
Yield Strength, Maximum	None	Maximum for each grade	Tables 3A, 3B
UTS, Maximum	None	Maximum for each grade	Tables 3A, 3B
Fracture Toughness	None required	Required for all grades	6.2.5; 9.3.5; 9.10.4; 9.12.6; Table 14
Repair by welding of pipe body, plate, and skelp	Permitted	Prohibited	5.3.2; 9.9; B.1; B.2
Repair by welding of weld seams without filler metal	Permitted by agreement	Prohibited	4.3; 9.8.5.6; 9.9; B.1.2; B.4
Certification	Certificates when specified per SR15	Certificates (SR15.1) mandatory	12.1
Traceability	Traceable only until all tests are passed, unless SR 15 is specified	Traceable after completion of tests (SR15.2) mandatory	5.6

04

04

04

APPENDIX K—END LOAD COMPENSATION FOR HYDROSTATIC TEST PRESSURES IN EXCESS OF 90% OF SPECIFIED MINIMUM YIELD STRENGTH (NORMATIVE)

(By agreement between the purchaser and the manufacturer, the following method may be used to determine the hydrostatic test pressure.)

K.1 As a measure to prevent distortion when testing at pressures equivalent to stresses in excess of 90% of specified minimum yield strength, the manufacturer may apply a calculation to compensate for the forces applied to the pipe end that produce a compressive longitudinal stress. The calculation in this appendix is based on Barlow's equation (see 9.4.3) modified by a factor based on the Maximum Shear Theory (see note). The calculation may be applied only when testing in excess of 90% of the specified minimum yield strength. In no case may the gage pressure for testing be less than that calculated using Barlow's equation at 90% of specified minimum yield strength.

Note: The calculation is an approximation of the effective hoop stress (SE), which is practical for application under mill pipe testing conditions. Other calculations provide closer approximations of effective hoop stress but are complex and therefore impractical for application.

K.2 The test pressure calculated shall be rounded to the nearest 10 psi (100 kPa).

K.3 The hydrostatic test pressure compensated for pipe end loading shall be calculated according to the following equation:

U.S. Customary Unit Equation:

$$P_1 = \frac{S_E - \frac{P_R A_R}{A_p}}{\frac{D}{2t} - \frac{A_1}{A_p}}$$

SI Unit Equation:

$$P_1 = 1000 \frac{S_E - \frac{P_R A_R}{A_p}}{\frac{D}{2t} - \frac{A_1}{A_p}}$$

where

A_1 = internal cross-sectional area of pipe,

A_p = cross-sectional area of pipe wall,

A_R = cross-sectional area of ram, in.² (mm²),

P_1 = hydrostatic test pressure in psi (kPa),

P_R = internal pressure on end-sealing ram, psi (kPa),

S_E = effective hoop stress in psi (MPa) equal to a percentage of the specified minimum yield strength,

D = specified outside diameter, in. (mm),

t = specified wall thickness, in. (mm).

K.4 The above equation may be manipulated algebraically to provide calculation in other terms appropriate to the manufacturer's testing facility.

K.5 Appropriate techniques for the control of effective hoop stress based on measurements of internal pipe and ram pressures vary according to hydrotester system design. The manufacturer shall provide a control technique appropriate to his installation.

APPENDIX M—CONVERSION PROCEDURES

The following procedures were used to make the soft metric conversions of U.S. Customary units to SI units in the metric conversion of API Spec 5L.

M.1 Fractions

Fractions and numbers with fractions in U.S. Customary units were converted to the full decimal equivalent in U.S. Customary units without rounding, and the full decimal equivalents in U.S. Customary units were then converted to SI values using the following formula:

$$N_m = 25.4 \cdot N$$

where

N_m = the SI equivalent of dimensions with fractions in U.S. Customary units, mm,

N = the full decimal equivalent of dimensions with fractions without rounding, in.

The SI equivalents of dimensions with fractions in U.S. Customary units were then rounded to the appropriate number of places in mm.

M.2 Outside Diameter

The U.S. Customary values for outside diameters of pipe and couplings were converted to SI values using the following formula:

$$D_m = 25.4 \cdot D$$

where

D_m = SI outside diameter, mm,

D = outside diameter, in.

The SI outside diameters of pipe and couplings smaller than size 18 were rounded to the nearest 0.1 mm. The SI outside diameters of pipe and couplings size 18 and larger were rounded to the nearest 1.0 mm.

M.3 Wall Thickness

The U.S. Customary values for wall thickness were converted to SI values using the following formula:

$$t_m = 25.4 \cdot t$$

where

t_m = SI wall thickness, mm,

t = wall thickness, in.

The SI wall thicknesses were rounded to the nearest 0.1 mm.

M.4 Inside Diameter

The SI inside diameters of pipe were calculated (not converted) using the following formula:

$$d_m = D_m - 2 \cdot t_m$$

where

d_m = SI inside diameter, mm,

D_m = SI outside diameter, mm,

t_m = SI wall thickness, mm.

The SI inside diameters were rounded to the nearest 0.1 mm.

M.5 Plain-end Mass Per Unit Length

The SI plain-end mass per unit length were calculated (not converted) using the following formula:

$$W_{pem} = 0.02466(D_m - t_m)t_m$$

where

W_{pem} = SI plain-end mass per unit length, kg/m,

D_m = SI outside diameter, mm,

t_m = SI wall thickness, mm.

The SI plain-end mass per unit length were rounded to the nearest 0.01 kg/m.

M.6 Yield Strength and Tensile Strength

The U.S. Customary values for yield strength and tensile strength were converted to SI values using the following formula:

$$y_{s_m} = 0.00689476 \cdot y_s$$

$$t_{s_m} = 0.00689476 \cdot t_s$$

where

y_{sm} = SI yield strength, MPa,

y_s = yield strength, psi,

t_{sm} = SI tensile strength, MPa,

t_s = tensile strength, psi.

The converted SI strengths were rounded to the nearest 1 MPa.

M.7 Hydrostatic Test Pressure

The U.S. Customary values for hydrostatic test pressures for all sizes of threaded pipe, all Grade A25 plain-end pipe smaller than size $5^{9/16}$, and all Grade A and Grade B plain-end pipe smaller than size $2^{3/8}$ were converted to SI values using the following formula:

$$P_m = 0.006\ 894\ 76 \cdot P$$

The converted hydrostatic test pressures were rounded to the nearest 100 kPa.

The SI hydrostatic test pressures for plain-end size $5^{9/16}$, Grade A25 and for sizes $2^{3/8}$ and larger Grades A and higher were calculated (not converted) using the following formula:

$$P_m = 2\ 000 \cdot f \cdot y_{sm} \cdot t_m / D_m$$

where

P_m = SI hydrostatic test pressure, kPa,

P = hydrostatic test pressure, psi,

f = stress factor, see table below,

y_{sm} = SI yield strength, MPa,

t_m = SI wall thickness, mm,

D_m = SI outside diameter, mm.

The calculated hydrostatic test pressure were rounded to the nearest 100 kPa, not to exceed 17 200 kPa for sizes $3^{1/2}$ and smaller or 19 300 kPa for sizes larger than $3^{1/2}$.

The calculated standard hydrostatic test pressures for Grades X42 and higher were rounded to the nearest 100 kPa, not to exceed 20 700 kPa. The calculated alternative hydrostatic test pressure for Grades X42 and higher were rounded to the nearest 100 kPa, not to exceed 50 000 kPa for pipes smaller than size 16, or 25 000 kPa for pipes sizes 16 and larger.

Grade	Size	<i>f</i> Factor	
		Standard Test Pressure	Alternative Test Pressure
A25	$5^{9/16}$	0.60	—
A & B	$\geq 2^{3/8}$	0.60	0.75
X42 & higher	$\leq 5^{9/16}$	0.60	0.75
	$> 5^{9/16}$ and $\leq 8^{5/8}$	0.75	0.75
	$> 8^{5/8}$ and < 20	0.85	0.85
	≥ 20	0.90	0.90

M.8 Temperature

The U.S. Customary values for temperatures were converted to SI values using the following formula:

$$^{\circ}\text{C} = 5/9 (^{\circ}\text{F} - 32)$$

where

$^{\circ}\text{C}$ = SI temperature, degrees Celsius,

$^{\circ}\text{F}$ = temperature, degrees Fahrenheit.

The SI temperatures were rounded to the nearest 1 $^{\circ}\text{C}$.

M.9 Charpy Impact Energy

The U.S. Customary values for impact energy were converted to SI values using the following formula:

$$E_m = 1.355\ 82 \cdot E$$

where

E_m = energy, J,

E = energy, ft-lb.

The SI energy values were rounded to the nearest 1 J.

M.10 Minimum Length of Couplings

The U.S. Customary values for the minimum lengths of couplings in inches and fractions were converted to full decimal equivalents in U.S. Customary units without rounding, and then the full decimal equivalents were converted to SI values using the following formula:

$$N_{Lm} = 25.4 \cdot N_L$$

where

N_{Lm} = SI minimum length of couplings, mm,

N_L = the full decimal equivalent, without rounding, of the minimum lengths of couplings, in.

The SI minimum lengths of coupling were rounded to the nearest 0.01 mm.

M.11 Diameter of Coupling Recess

The U.S. Customary values for diameters of the coupling recess's were converted to SI values using the following formula:

$$Q_m = 25.4 \cdot Q$$

where

Q_m = SI diameter of the coupling recess, mm,

Q = diameter of the coupling recess, in.

The SI diameter of the couplings recesses were rounded to the nearest 0.01 mm.

M.12 Width of the Coupling Bearing Face

The U.S. Customary values for widths of the bearing face of couplings were converted to SI values using the following formula:

$$b_m = 25.4 \cdot b$$

where

b_m = SI width of the coupling bearing face, mm,

b = width of the coupling bearing face, in.

The SI width of the coupling bearing face were rounded to the nearest 0.1 mm.

M.13 Coupling Weights

The U.S. Customary values for calculated coupling weights were converted to SI values using the following formula:

$$W_m = 0.453\,592\,4 \cdot w$$

where

W_m = SI calculated coupling weight, kg,

w = calculated coupling weight, lb.

The SI calculated coupling weights were rounded to the nearest 0.01 kg.

