

THE
FEDERAL REPORTER.

VOLUME 119.

CASES ARGUED AND DETERMINED

IN THE

CIRCUIT COURTS OF APPEALS AND CIRCUIT
AND DISTRICT COURTS OF THE
UNITED STATES.

PERMANENT EDITION.

FEBRUARY—MARCH, 1903.

A TABLE OF STATUTES CONSTRUED IS GIVEN
IN THE INDEX.

ST. PAUL:
WEST PUBLISHING CO.
1903.

COPYRIGHT, 1903,
BY
WEST PUBLISHING COMPANY.

FEDERAL REPORTER, VOLUME 119.

JUDGES

OF THE

**UNITED STATES CIRCUIT COURTS OF APPEALS AND THE
CIRCUIT AND DISTRICT COURTS.**

FIRST CIRCUIT.

Hon. OLIVER WENDELL HOLMES, Circuit Justice.....Washington, D. C.
Hon. LE BARON B. COLT, Circuit Judge.....Bristol, R. I.
Hon. WILLIAM L. PUTNAM, Circuit Judge.....Portland, Me.
Hon. CLARENCE HALE, District Judge, MainePortland, Me.
Hon. EDGAR ALDRICH, District Judge, New Hampshire.....Littleton, N. H.
Hon. FRANCIS C. LOWELL, District Judge, Massachusetts.....Boston, Mass.
Hon. ARTHUR L. BROWN, District Judge, Rhode Island.....Providence, R. I.

SECOND CIRCUIT.

Hon. RUFUS W. PECKHAM, Circuit Justice.....Washington, D. C.
Hon. WILLIAM J. WALLACE, Circuit Judge.....Albany, N. Y.
Hon. E. HENRY LACOMBE, Circuit Judge.....New York; N. Y.
Hon. WILLIAM K. TOWNSEND, Circuit Judge.....New Haven, Conn.
Hon. ALFRED C. COXE, Circuit JudgeUtica, N. Y.
Hon. JAMES P. PLATT, District Judge, ConnecticutHartford, Conn.
Hon. GEORGE W. RAY, District Judge, N. D. New YorkNorwich, N. Y.
Hon. GEORGE B. ADAMS, District Judge, S. D. New YorkNew York, N. Y.
Hon. EDWARD B. THOMAS, District Judge, E. D. New York....29 Liberty St., New York.
Hon. HOYT H. WHEELER, District Judge, Vermont.....Brattleboro, Vt.
Hon. JOHN R. HAZEL, District Judge, W. D. New York.....Buffalo, N. Y.

THIRD CIRCUIT.

Hon. GEORGE SHIRAS, Jr., Circuit Justice¹.....Washington, D. C.
Hon. MARCUS W. ACHESON, Circuit Judge.....Pittsburgh, Pa.
Hon. GEORGE M. DALLAS, Circuit Judge.....Philadelphia, Pa.
Hon. GEORGE GRAY, Circuit JudgeWilmington, Del.
Hon. EDWARD G. BRADFORD, District Judge, Delaware.....Wilmington, Del.
Hon. ANDREW KIRKPATRICK, District Judge, New Jersey.....Newark, N. J.
Hon. JOHN B. McPHERSON, District Judge, E. D. Pennsylvania.....Philadelphia, Pa.
Hon. ROBERT WODROW ARCHBALD, District Judge, M. D. Pennsylvania..Scranton, Pa.
Hon. JOSEPH BUFFINGTON, District Judge, W. D. Pennsylvania.....Pittsburgh, Pa.

¹ Resigned February 24, 1903.

FOURTH CIRCUIT.

Hon. MELVILLE W. FULLER, Circuit Justice.....	Washington, D. C.
Hon. NATHAN GOFF, Circuit Judge.....	Clarksburg, W. Va.
Hon. CHARLES H. SIMONTON, Circuit Judge.....	Charleston, S. C.
Hon. THOMAS J. MORRIS, District Judge, Maryland.....	Baltimore, Md.
Hon. THOMAS R. PURNELL, District Judge, E. D. North Carolina.....	Raleigh, N. C.
Hon. JAMES E. BOYD, District Judge, W. D. North Carolina.....	Greensboro, N. C.
Hon. WILLIAM H. BRAWLEY, District Judge, E. and W. D. South Car.....	Charleston, S. C.
Hon. EDMUND WADDILL, Jr., District Judge, E. D. Virginia.....	Richmond, Va.
Hon. HENRY CLAY McDOWELL, District Judge, W. D. Virginia.....	Lynchburg, Va.
Hon. JOHN J. JACKSON, District Judge, N. D. West Virginia.....	Parkersburg, W. Va.
Hon. BENJAMIN F. KELLER, District Judge, S. D. West Virginia.....	Branwell, W. Va.

FIFTH CIRCUIT.

Hon. EDWARD D. WHITE, Circuit Justice.....	Washington, D. C.
Hon. DON A. PARDEE, Circuit Judge.....	New Orleans, La.
Hon. A. P. McCORMICK, Circuit Judge.....	Dallas, Tex.
Hon. DAVID D. SHELBY, Circuit Judge.....	Huntsville, Ala.
Hon. THOMAS GOODE JONES, District Judge, M. and N. D. Alabama.....	Montgomery, Ala.
Hon. HARRY T. TOULMIN, District Judge, S. D. Alabama.....	Mobile, Ala.
Hon. CHARLES SWAYNE, District Judge, N. D. Florida.....	Pensacola, Fla.
Hon. JAMES W. LOCKE, District Judge, S. D. Florida.....	Jacksonville, Fla.
Hon. WILLIAM T. NEWMAN, District Judge, N. D. Georgia.....	Atlanta, Ga.
Hon. EMORY SPEER, District Judge, S. D. Georgia.....	Macon, Ga.
Hon. CHARLES PARLANGE, District Judge, E. D. Louisiana.....	New Orleans, La.
Hon. ALECK BOARMAN, District Judge, W. D. Louisiana.....	Shreveport, La.
Hon. HENRY C. NILES, District Judge, N. and S. D. Mississippi.....	Kosciusko, Miss.
Hon. DAVID E. BRYANT, District Judge, E. D. Texas.....	Sherman, Tex.
Hon. EDWARD R. MEEK, District Judge, N. D. Texas.....	Ft. Worth, Tex.
Hon. THOMAS S. MAXEY, District Judge, W. D. Texas.....	Austin, Tex.
Hon. WALLER T. BURNS, District Judge, S. D. Texas.....	Houston, Tex.

SIXTH CIRCUIT.

Hon. JOHN M. HARLAN, Circuit Justice.....	Washington, D. C.
Hon. HENRY F. SEVERENS, Circuit Judge.....	Kalamazoo, Mich.
Hon. HORACE H. LURTON, Circuit Judge.....	Nashville, Tenn.
Hon. WILLIAM R. DAY, Circuit Judge ²	Canton, Ohio.
Hon. ANDREW M. J. COCHRAN, District Judge, E. D. Kentucky.....	Covington, Ky.
Hon. WALTER EVANS, District Judge, W. D. Kentucky.....	Louisville, Ky.
Hon. HENRY H. SWAN, District Judge, E. D. Michigan.....	Detroit, Mich.
Hon. GEORGE P. WANTY, District Judge, W. D. Michigan.....	Grand Rapids, Mich.
Hon. AUGUSTUS J. RICKS, District Judge, N. D. Ohio.....	Cleveland, Ohio.
Hon. FRANCIS J. WING, District Judge, N. D. Ohio.....	Cleveland, Ohio.
Hon. ALBERT C. THOMPSON, District Judge, S. D. Ohio.....	Cincinnati, Ohio.
Hon. CHARLES D. CLARK, District Judge, E. and M. D. Tennessee.....	Chattanooga, Tenn.
Hon. ELI S. HAMMOND, District Judge, W. D. Tennessee.....	Memphis, Tenn.

SEVENTH CIRCUIT.

Hon. HENRY B. BROWN, Circuit Justice.....	Washington, D. C.
Hon. JAMES G. JENKINS, Circuit Judge.....	Milwaukee, Wis.
Hon. PETER S. GROSSCUP, Circuit Judge.....	Chicago, Ill.
Hon. FRANCIS E. BAKER, Circuit Judge.....	Indianapolis, Ind.
Hon. CHRISTIAN C. KOHLSAAT, District Judge, N. D. Illinois.....	Chicago, Ill.

² Appointed Associate Justice to United States Supreme Court February 25, 1903.

JUDGES OF THE COURTS.

Hon. J. OTIS HUMPHREY, District Judge, S. D. Illinois.....Springfield, Ill.
 Hon. WILLIAM H. SEAMAN, District Judge, E. D. Wisconsin.....Sheboygan, Wis.
 Hon. ROMANZO BUNN, District Judge, W. D. Wisconsin.....Madison, Wis.

EIGHTH CIRCUIT.

Hon. DAVID J. BREWER, Circuit Justice.....Washington, D. C.
 Hon. HENRY C. CALDWELL, Circuit Judge.....Little Rock, Ark.
 Hon. WALTER H. SANBORN, Circuit Judge.....St. Paul, Minn.
 Hon. AMOS M. THAYER, Circuit Judge.....St. Louis, Mo.
 Hon. JACOB TRIEBER, District Judge, E. D. Arkansas.....Little Rock, Ark.
 Hon. JOHN H. ROGERS, District Judge, W. D. Arkansas.....Ft. Smith, Ark.
 Hon. MOSES HALLETT, District Judge, Colorado.....Denver, Colo.
 Hon. OLIVER P. SHIRAS, District Judge, N. D. Iowa.....Dubuque, Iowa.
 Hon. SMITH McPHERSON, District Judge, S. D. Iowa.....Red Oak, Iowa.
 Hon. WILLIAM C. HOOK, District Judge, Kansas.....Leavenworth, Kan.
 Hon. WM. LOCHREN, District Judge, Minnesota.....Minneapolis, Minn.
 Hon. ELMER B. ADAMS, District Judge, E. D. Missouri.....St. Louis, Mo.
 Hon. JOHN F. PHILIPS, District Judge, W. D. Missouri.....Kansas City, Mo.
 Hon. W. H. MUNGER, District Judge, Nebraska.....Omaha, Neb.
 Hon. CHARLES F. AMIDON, District Judge, North Dakota.....Fargo, N. D.
 Hon. JOHN E. CARLAND, District Judge, South Dakota.....Sioux Falls, S. D.
 Hon. JOHN A. MARSHALL, District Judge, Utah.....Salt Lake City, Utah.
 Hon. JOHN A. RINER, District Judge, Wyoming.....Cheyenne, Wyo.

NINTH CIRCUIT.

Hon. JOSEPH McKENNA, Circuit Justice.....Washington, D. C.
 Hon. WM. W. MORROW, Circuit Judge.....San Francisco, Cal.
 Hon. WILLIAM B. GILBERT, Circuit Judge.....Portland, Or.
 Hon. ERSKINE M. ROSS, Circuit Judge.....Los Angeles, Cal.
 Hon. JOHN J. DE HAVEN, District Judge, N. D. California.....San Francisco, Cal.
 Hon. OLIN WELLBORN, District Judge, S. D. California.....Los Angeles, Cal.
 Hon. HIRAM KNOWLES, District Judge, Montana.....Helena, Mont.
 Hon. CORNELIUS H. HANFORD, District Judge, Washington.....Seattle, Wash.
 Hon. THOMAS P. HAWLEY, District Judge, Nevada.....Carson City, Nev.
 Hon. CHARLES B. BELLINGER, District Judge, Oregon.....Portland, Or.
 Hon. JAMES H. BEATTY, District Judge, Idaho.....Boise City, Idaho.

CASES REPORTED.

	Page		Page
Abner Doble Co. v. United States (C. C. A.)	152	Bradley Timber Co., White v. (D. C.)	989
Adair v. Askey (C. C. A.)	1018	Brown v. Northwestern Mut. Life Ins. Co., two cases (C. C. A.)	148
Adams Exp. Co., United States v. (D. C.)	240	Brown, Clark v. (C. C. A.)	130
Alaska Packers' Ass'n v. Letson (C. C.)	599	Brown, Lanyon Zinc Co. v. (C. C. A.)	918
Albro v. Manhattan Life Ins. Co. (C. C.)	629	Brown, Oregon King Min. Co. v. (C. C. A.)	48
Alexander, United States v. (C. C.)	1015	Brown, United States v. (C. C.)	482
Allan S. S. Co., Dunton v. (C. C. A.)	590	Brown's Valley Irr. Dist., People v. (C. C.)	535
Allen, Eltonhead v. (C. C. A.)	126	Buckley, Post v. (C. C.)	249
American Bell Tel. Co. v. National Tel. Mfg. Co. (C. C. A.)	893	Buenos Aires, The (D. C.)	493
American Can Co., Pistoner v. (C. C.)	496	Burger v. Lucas (C. C.)	372
American Health Food Co., Postum Cereal Co. v. (C. C. A.)	848	Burrows v. Gower (D. C.)	616
American Law Book Co., Edward Thompson Co. v. (C. C.)	217	Buston v. Pennsylvania R. Co. (C. C. A.)	808
American Locomotive Co., Dickson Mfg. Co. v. (C. C.)	488	Cady v. Associated Colonies (C. C.)	420
American Nat. Bank v. Watkins (C. C. A.)	545	Cahill, Olsen v. (D. C.)	468
American Naval Stores Co., Lewis v. (C. C.)	391	Calivada Colonization Co. v. Hays (C. C.)	202
American Raveller Co., Union Special Sewing Mach. Co. v. (C. C.)	367	Calivada Colonization Co. v. Kroegher (C. C. A.)	641
American Raveller Co., Union Special Sewing Mach. Co. v. (C. C.)	369	Callahan, Wong Him v. (C. C.)	381
American Sugar Refining Co. v. City of New Orleans (C. C. A.)	691	Campbell v. Milliken (C. C.)	981
Ammon-Stivers Min. Co. v. Great Northern Mining & Development Co. (C. C.)	377	Campbell v. Milliken (C. C.)	982
Amsinck v. Pomares (D. C.)	373	Carcaba, United States v. (C. C. A.)	1022
Andrew D. Meloy & Co. v. Donnelly (C. C.)	456	Carrroll & Bro. Co. v. Young (C. C. A.)	576
Askey, Adair v. (C. C. A.)	1018	Casserleigh v. Wood (C. C. A.)	308
Associated Colonies, Cady v. (C. C.)	420	Cassidy Fork Boom & Lumber Co. v. Roaring Creek & C. R. Co. (C. C.)	425
Atchison, T. & S. F. R. Co., Sawyer v. (C. C.)	252	Certain Land in Lawrence, In re (D. C.)	453
Atlantic Trust Co., Chapman v. (C. C. A.)	257	Champagne Mining & Milling Co., Neilson v. (C. C. A.)	123
Atlantis, The (C. C. A.)	568	Chapman v. Atlantic Trust Co. (C. C. A.)	257
Australian Knitting Co. v. Wright's Health Underwear Co. (C. C. A.)	921	Chauncey v. Dyke Bros. (C. C. A.)	1
Baber, In re (D. C.)	520	Chesapeake & O. Coal Agency Co. v. Fire Creek Coal & Coke Co. (C. C.)	942
Bailey, Rush v. (C. C. A.)	1019	Chestnut Hill Casino Co., Thompson Scenic R. Co. v. (C. C.)	35
Bailey, Rush v. (C. C. A.)	1020	Chicago, B. & Q. R. Co., Union Terminal R. Co. v. (C. C.)	21
Baldwin, In re (D. C.)	796	Chicago Hydraulic Press Brick Co., Kimbell v. (C. C. A.)	10
Baltimore & O. R. Co. v. Wabash R. Co. (C. C. A.)	678	China & Japan Trading Co. v. Davis (C. C. A.)	688
Barndall v. Boley (C. C.)	191	China & Japan Trading Co. v. Davis (C. C. A.)	1018
Bashinski v. Talbott (C. C. A.)	337	Cissna, Stockley v. (C. C. A.)	812
Bent v. Hall (C. C. A.)	342	City of Chicago v. Le Moynes (C. C. A.)	662
Bidwell, Mosle v. (C. C.)	480	City of Chicago v. Pennsylvania Co. (C. C. A.)	497
Bishop & Babcock Co. v. Levine (C. C.)	363	City of Chicago, Elkins v., two cases (C. C.)	957
Board of Com'rs of Franklin County, Ohio, v. Gardiner Sav. Inst. (C. C. A.)	36	City of New Orleans, American Sugar Refining Co. v. (C. C. A.)	691
Boker, Coates v. (C. C. A.)	358	City of New Orleans, Emsheimer v. (C. C. A.)	1019
Boley, Barnsdall v. (C. C.)	191	City of New York, Dailey v. (D. C.)	1005
Boston & M. Consol. Copper & Silver Min. Co., MacGinniss v. (C. C. A.)	96	City of New York, Fisk v. (D. C.)	256
Bouker, The John A. (D. C.)	493	City of Ottumwa, Iowa, v. City Water Supply Co. (C. C. A.)	315

	Page		Page
City of Philadelphia, McCaulley v. (C. C. A.)	580	Edward Thompson Co. v. American Law Book Co. (C. C.)	217
City Water Supply Co., City of Ottumwa, Iowa, v. (O. C. A.)	315	Egan State Bank v. Rice (C. C. A.)	107
Claffin Co. v. Furtick (C. C.)	429	E. H. Gato Cigar Co., United States v. (C. C. A.)	1022
Clark, The Joseph M. (D. C.)	459	Elizabeth City Cotton Mills v. Loeb (C. C. A.)	154
Clark v. Brown (C. C. A.)	130	Elkins v. City of Chicago, two cases (C. O.)	957
Clawson, United States v. (D. C.)	994	Elliott v. Felton (C. C. A.)	270
Cleveland Tel. Co., Illinois Commission Co. v. (C. C. A.)	301	Ellis v. John Crossley & Sons (C. C.)	779
Coates v. Boker (C. C. A.)	358	Eltonhead v. Allen (C. C. A.)	126
Cohn, George Frost Co. v. (C. C. A.)	505	Emsheimer v. City of New Orleans (C. C. A.)	1019
Coker v. Monaghan Mills (C. C.)	706	Engelhorn v. United States (C. C.)	1022
Collier v. Mutual Reserve Fund Life Ass'n (C. C.)	617	Farmers' Cotton Seed Oil Mill & Ginnery, Richmond Guano Co. v. (C. C.)	709
Commonwealth Iron Co., Salem Iron Co. v. (C. C. A.)	593	Farmers' Mfg. Co. v. Spruks Mfg. Co. (C. C.)	594
Commonwealth of Virginia v. De Hart (C. C.)	626	Farrar, Florence Oil & Refining Co. v. (C. C. A.)	150
Commonwealth Title, Ins. & Trust Co., Sprigg v. (C. C.)	434	Fayerweather v. Ritch (C. C.)	1023
Connecticut Web Co., MacWilliam v. (C. C.)	509	Federal Manufacturing & Printing Co. v. International Bank Note Co. (C. C.)	385
Consolidated Rubber Tire Co. v. Finley Rubber Tire Co. (C. C.)	705	Feil v. Wabash R. Co. (C. C.)	490
Consolidated Store-Service Co. v. Winters (C. C.)	614	Felton, Elliott v. (C. C. A.)	270
Consolidated Traction Co., Dickinson v. (C. C. A.)	871	Fenno v. Primrose (C. C. A.)	801
Coonrod v. Kelly (C. C. A.)	841	Ferguson, The William E. (C. C. A.)	1022
Countryman, In re (D. C.)	639	Field, McNally v. (C. C.)	445
Creede & Cripple Creek Min. & Mill Co., Uinta Tunnel Min. & Transp. Co. v. (C. C. A.)	164	Files v. Davis (C. C.)	1002
Crescent City Transp. Co., Townsley v. (C. C. A.)	118	Filhiol v. Torney (C. C.)	974
Crossley & Sons, Ellis v. (C. C.)	779	Finley Rubber Tire Co., Consolidated Rubber Tire Co. v. (C. C.)	705
Dailey v. City of New York (D. C.)	1005	Fire Creek Coal & Coke Co., Chesapeake & O. Coal Agency Co. v. (C. C.)	942
Daisley v. Douglass (C. C.)	485	Fischer, Ludington Novelty Co. v. (C. C.)	937
Dancel, Goodyear Shoe Machinery Co. of Portland, Me., v. (C. C. A.)	692	Fisk v. City of New York (D. C.)	256
David v. Levy (C. C.)	799	Fitchburg R. Co., Green v. (C. C. A.)	872
Davis, In re (D. C.)	950	Fitzpatrick v. Graham (C. C. A.)	353
Davis, China & Japan Trading Co. v. (C. C. A.)	688	Five Hundred and Eighty-One Diamonds v. United States (C. C. A.)	556
Davis, China & Japan Trading Co. v. (C. C. A.)	1018	Florence Oil & Refining Co. v. Farrar (C. C. A.)	150
Davis, Files v. (C. C.)	1002	Fontaine, McClintock v. (C. C.)	448
De Hart, Commonwealth of Virginia v. (C. C.)	626	Fontana, The (C. C. A.)	853
Del Norte, The (C. C. A.)	118	Francklyn v. United States (C. C.)	470
De Q. Bottle Stopper Co., Hutter v. (C. C.)	190	Fred Macey Co., Globe-Wernicke Co. v. (C. C. A.)	696
De Sola v. Pomares (D. C.)	373	French, The Jonas H. (D. C.)	462
Dickinson v. Consolidated Traction Co. (C. C. A.)	871	Friedly v. Giddings (C. C.)	438
Dickson v. Marshall (C. C. A.)	1021	Frost Co. v. Cohn (C. C. A.)	505
Dickson Mfg. Co. v. American Locomotive Co. (C. C.)	488	Furtick, H. B. Claffin Co. v. (C. C.)	429
Doble Co. v. United States (C. C. A.)	152	Gannett v. Ruppert (C. C.)	221
Dobson v. Peck Bros. & Co. (C. C.)	254	Gardiner Sav. Inst., Board of Com'rs of Franklin County, Ohio, v. (C. C. A.)	36
Dodge, Nevada Nat. Bank v. (C. C. A.)	57	Gato Cigar Co., United States v. (C. C. A.)	1022
Donnelly, Andrew D. Meloy & Co. v. (C. C.)	456	General Electric Co. v. Wise (C. C.)	922
Douglass, Daisley v. (C. C.)	485	Gentry, United States v. (C. C. A.)	70
Dressel v. North State Lumber Co. (D. C.)	531	George Carroll & Bro. Co. v. Young (C. C. A.)	576
Dunton v. Allan S. S. Co. (C. C. A.)	590	George Frost Co. v. Cohn (C. C. A.)	505
Dyke Bros., Chauncey v. (C. C. A.)	1	Giddings, Friedly v. (C. C.)	438
Edison v. Lubin (C. C.)	993	Glass, In re (D. C.)	509
Edson, In re (D. C.)	487	Glazier, United Blue-Flame Oil Stove Co. v. (C. C. A.)	157
		Globe-Wernicke Co. v. Fred Macey Co. (C. C. A.)	696
		Goodyear Shoe Machinery Co. of Portland, Me., v. Dancel (C. C. A.)	692
		Goss Printing-Press Co. v. Scott (C. C.)	941

CASES REPORTED.

ix

	Page		Page
Gower, Burrows v. (D. C.)	816	Larkin, Howe v. (C. C.)	1005
Graham, Fitzpatrick v. (C. C. A.)	353	Larkin, Masseth v. (C. C. A.)	171
Gray v. Schneider (C. C.)	474	Laverge v. United States (C. C.)	481
Great Northern Mining & Development Co., Ammon-Stivers Min. Co. v. (C. C.)	377	Lehtola, Troy White Granite Co. v. (C. C. A.)	1021
Green v. Fitchburg R. Co. (C. C. A.)	962	Le Moine, City of Chicago v. (C. C. A.)	662
Guild, Pringle v. (C. C.)	342	Leonard, Ludington Novelty Co. v. (C. C.)	937
Hall, Bent v. (C. C. A.)	186	Leslie, In re (D. C.)	406
Hall, Murjahn v. (C. C.)	468	Letson, Alaska Packers' Ass'n v. (C. C.)	599
Hallenbeck, The O. L. (D. C.)	873	Levine, Bishop & Babcock Co. v. (C. C.)	363
Hallett v. New England Roller Grate Co. (C. C. A.)	471	Levy, David v. (C. C.)	799
Hanneman, Richter v. (C. C.)	246	Lewis v. American Naval Stores Co. (C. C.)	391
Hare, In re (D. C.)	997	Lewis, Hibernia Bank & Trust Co. v. (C. C.)	391
Harrison v. Hughes (D. C.)	978	Lew Poy Dew, United States v. (D. C.)	784
Hawes v. Warren (C. C.)	202	Liberty, The (D. C.)	539
Hays, Calivada Colonization Co. v. (C. C.)	429	Lipset, In re (D. C.)	379
H. B. Clafin Co. v. Furtick (C. C.)	83	Littlejohn v. United States (C. C.)	483
Heckman v. Sutter (C. C. A.)	391	Loeb, Elizabeth City Cotton Mills v. (C. C. A.)	154
Hibernia Bank & Trust Co. v. Lewis (C. C.)	157	Lorsch v. United States (C. C.)	476
Hines v. Texas & P. R. Co. (C. C. A.)	1019	Lubin, Edison v. (C. C.)	993
Holly, Nashville, C. & St. L. R. Co. v. (C. C. A.)	1003	Lucas, Burger v. (C. C.)	372
Howe v. Larkin (C. C.)	465	Ludington Novelty Co. v. Fischer (C. C.)	937
Howell, In re (D. C.)	987	Ludington Novelty Co. v. Leonard (C. C.)	937
Hoyt, In re (D. C.)	346	McCaulley v. City of Philadelphia (C. C. A.)	580
Hudson v. Mercantile Nat. Bank (C. C. A.)	764	McClaine v. Rankin (C. C. A.)	110
Hudson v. Wood (C. C.)	1021	McClintock v. Fontaine (C. C.)	448
Hudson, Townsend v. (C. C. A.)	997	McCormick v. Shippy (D. C.)	226
Hughes, Harrison v. (D. C.)	188	McCormy, United States v. (C. C. A.)	861
Hurlbut v. United States Mailing Tube Co. (C. C.)	190	McElroy, United States v. (C. C. A.)	478
Hutter v. De Q. Bottle Stopper Co. (C. C.)	114	Macey Co., Globe-Wernicke Co. v. (C. C. A.)	696
Hy-yu-tse-mil-kin v. Smith (C. C. A.)	301	MacGinniss v. Boston & M. Consol. Copper & Silver Min. Co. (C. C. A.)	96
Illinois Commission Co. v. Cleveland Tel. Co. (C. C. A.)	385	McLeod, United States v. (C. C.)	416
International Bank Note Co., Federal Manufacturing & Printing Co. v. (C. C.)	493	McNally v. Field (C. C.)	445
John A. Bouker, The (D. C.)	779	MacWilliam v. Connecticut Web Co. (C. C.)	509
John Crossley & Sons, Ellis v. (C. C.)	885	Manhattan Life Ins. Co., Albro v. (C. C.)	629
Johnson Co. v. Toledo Traction Co. (C. C. A.)	462	Marshall, Dickson v. (C. C. A.)	1021
Jonas H. French, The (D. C.)	459	Marshall, Underwood v. (C. C. A.)	1021
Joseph M. Clark, The (D. C.)	451	Marshall, Weddington v. (C. C. A.)	1021
J. S. Ogilvie Pub. Co., Patterson v. (C. C. A.)	841	Massachusetts Mohair Plush Co., Sanford Mills v. (C. C. A.)	355
Kelly, Coonrod v. (C. C. A.)	475	Masseth v. Larkin (C. C. A.)	171
Kenny v. Knight (C. C.)	1006	Meloy & Co. v. Donnelly (C. C.)	456
Kilgore v. Norman (C. C.)	102	Mercantile Nat. Bank, Hudson v. (C. C. A.)	346
Kimbell v. Chicago Hydraulic Press Brick Co. (C. C. A.)	1016	Mercantile Trust & Deposit Co. of Baltimore, Md., Northrop v. (C. C.)	969
King v. Southern R. Co. (C. C.)	1017	Miles v. United States (C. C. A.)	1019
King v. Southern R. Co. (C. C.)	1020	Miller v. Tennant-Stribling Shoe Co. (C. C. A.)	865
King, Sullivan v. (C. C. A.)	475	Milliken, Campbell v. (C. C.)	981
Knight, Kenny v. (C. C.)	641	Milliken, Campbell v. (C. C.)	982
Kroegher v. Calivada Colonization Co. (C. C. A.)	279	Monaghan Mills, Coker v. (C. C.)	706
Krutz, Washington Irr. Co. v. (C. C. A.)	383	Mosle v. Bidwell (C. C.)	480
Kwong Chin Chong v. United States (C. C.)	588	Mullins, United States v. (C. C. A.)	334
La Compagnie Francaises Des Cables Telegraphiques, Slaughter v. (C. C. A.)	349	Murjahn v. Hall (C. C.)	186
Langenbach, Roberts v. (C. C. A.)	1022	Murray, Standard Oil Co. v. (C. C. A.)	572
Langford, The (C. C. A.)	918	Mutual Reserve Fund Life Ass'n, Collier v. (C. C.)	617
Lanyon Zinc Co. v. Brown (C. C. A.)	1019	Mutual Reserve Fund Life Ass'n, Polk v. (C. C.)	491
		Nashville, C. & St. L. R. Co. v. Holly (C. C. A.)	1019
		Nassau Electric R. Co., Thomson-Houston Electric Co. v. (C. C. A.)	354

	Page		Page
National Phonograph Co., New York Phonograph Co. v. (C. C.)	544	Rankin, McClaine v. (C. C. A.)	110
National Tel. Mfg. Co., American Bell Tel. Co. v. (C. C. A.)	893	Remington Automobile & Motor Co., In re (D. C.)	441
National Tel. News Co. v. Western Union Tel. Co. (C. C. A.)	294	Reynolds v. Ritch (C. C.)	1023
Neilson v. Champagne Mining & Milling Co. (C. C. A.)	123	Rice, Egan State Bank v. (C. C. A.)	107
Nevada Nat. Bank v. Dodge (C. C. A.)	57	Richmond Guano Co. v. Farmers' Cotton Seed Oil Mill & Ginnery (C. C.)	709
Nevada Power, Light & Water Co., Peers v. (C. C.)	400	Richter v. Hanneman (C. C.)	471
New England Roller Grate Co., Hallett v. (C. C. A.)	873	Ridenour, United States v. (D. C.)	411
New York Air Brake Co., Westinghouse Air Brake Co. v. (C. C. A.)	874	Ritch, Fayerweather v. (C. C.)	1023
New York Central No. 8, The (D. C.)	493	Ritch, Reynolds v. (C. C.)	1023
New York Phonograph Co. v. National Phonograph Co. (C. C.)	544	Roaring Creek & C. R. Co., Cassidy Fork Boom & Lumber Co. v. (C. C.)	425
Nordlinger, United States v. (C. C.)	478	Roberts v. Langenbach (C. C. A.)	349
Norman, Kilgore v. (C. C.)	1006	Roosa, In re (D. C.)	542
Northern Pac. R. Co. v. Tynan (C. C. A.)	288	Rorick v. Railway Officials' & Employees' Acc. Ass'n (C. C. A.)	63
North Pacific Lumber Co., Olsen v. (C. C. A.)	77	Rothwell, York Mfg. Co. v. (C. C. A.)	144
Northrop v. Mercantile Trust & Deposit Co. of Baltimore, Md. (C. C.)	969	Ruppert, Gannett v. (C. C.)	221
North State Lumber Co., Dressel v. (D. C.)	531	Rush v. Bailey (C. C. A.)	1019
Northwestern Mut. Life Ins. Co., Brown v., two cases (C. C. A.)	148	Rush v. Bailey (C. C. A.)	1020
Ogilvie Pub. Co., Patte-son v. (C. C.)	451	Salem Iron Co. v. Commonwealth Iron Co. (C. C. A.)	593
Olcott, Witherspoon v. (C. C. A.)	175	Sanford Mills v. Massachusetts Mohair Plush Co. (C. C. A.)	355
O. L. Hallenbeck, The (D. C.)	468	Santo Domingo, The (D. C.)	386
Olsen v. Cahill (D. C.)	468	Sawyer v. Atchison, T. & S. F. R. Co. (C. C.)	252
Olsen v. North Pacific Lumber Co. (C. C. A.)	77	Schenectady R. Co., Thompson v. (C. C.)	634
Orange County Gas & Electric Co., Westinghouse Electric & Mfg. Co. v. (C. C.)	365	Schering v. United States (C. C.)	472
Orcutt, Supreme Council American Legion of Honor v. (C. C. A.)	682	Schering, United States v. (C. C.)	473
Oregon King Min. Co. v. Brown (C. C. A.)	48	Schering, United States v. (C. C.)	1023
Otis Elevator Co. v. Portland Co. (C. C.)	928	Schneider, Gray v. (C. C.)	474
Parschen, In re (C. C.)	976	Schoenemann v. United States (C. C. A.)	584
Parvin, Wilson v. (C. C. A.)	652	Scott, Goss Printing-Press Co. v. (C. C.)	941
Patterson v. J. S. Ogilvie Pub. Co. (C. C.)	451	Seaboard, The (D. C.)	375
Peck Bros. & Co., Dobson v. (C. C.)	254	Shachter, In re (D. C.)	1010
Peers v. Nevada Power, Light & Water Co. (C. C.)	400	Sherbourne v. Wilcox & Gibbs Sewing Mach. Co. (C. C.)	371
Pennewell, In re (C. C. A.)	139	Sheridan, United States v. (C. C.)	236
Pennsylvania Co., City of Chicago v. (C. C. A.)	497	Sheriff v. Turner (C. C.)	231
Pennsylvania R. Co., Buston v. (C. C. A.)	808	Sheriff v. Turner (C. C.)	782
People v. Brown's Valley Irr. Dist. (C. C.)	535	Shippy, McCormick v. (D. C.)	226
Perez, United States v. (C. C. A.)	1022	Simpson, In re (D. C.)	620
Perkins, United States v. (C. C.)	384	Slaughter v. La Compagnie Francaises Des Cables Telegraphiques (C. C. A.)	588
Pine Forest, The (D. C.)	999	Smith, In re (D. C.)	1004
Pinstoner v. American Can Co. (C. C.)	496	Smith, Hy-yu-tse-mil-kin v. (C. C. A.)	114
Polk v. Mutual Reserve Fund Life Ass'n (C. C.)	491	Soelberg v. Thames & Mersey Marine Ins. Co. (C. C. A.)	23
Pomares, Amsinck v. (D. C.)	373	Soelberg v. Western Assur. Co. of Toronto, Can. (C. C. A.)	23
Pomares, De Sola v. (D. C.)	373	Southern R. Co., King v. (C. C.)	1016
Portland Co., Otis Elevator Co. v. (C. C.)	928	Southern R. Co., King v. (C. C.)	1017
Post v. Buckley (C. C.)	249	Sprigg v. Commonwealth Title Ins. & Trust Co. (C. C.)	434
Postum Cereal Co. v. American Health Food Co. (C. C. A.)	848	Spruks Mfg. Co., Farmers' Mfg. Co. v. (C. C.)	594
Powers v. United States (C. C. A.)	562	Standard Oil Co. v. Murray (C. C. A.)	572
Primrose, Fenno v. (C. C. A.)	801	Stanley, Wright v. (C. C. A.)	330
Pringle v. Guild (C. C.)	962	Stearns, Union Trust Co. v. (C. C.)	790
Railway Officials' & Employees' Acc. Ass'n, Rorick v. (C. C. A.)	63	Stevens, Weston Electrical Instrument Co. v. (C. C.)	181
		Stewart v. United States (C. C. A.)	89
		Stockley v. Cissna (C. C. A.)	812
		Sullivan v. King (C. C. A.)	1020
		Superior Mfg. Co., Tykeson v. (C. C. A.)	1021
		Supreme Council American Legion of Honor v. Orcutt (C. C. A.)	682
		Supreme Lodge Knights of Pythias v. Wellenvoss (C. C. A.)	671

CASES REPORTED.

	Page		Page
Sutter, Heckman v. (C. C. A.).....	83	United States v. Schering (C. C.).....	1023
Talbott, Bashinski v. (C. C. A.).....	337	United States v. Sheridan (C. C.).....	236
Taylor Gas Producer Co. v. Wood (C. C.)	966	United States, Abner Doble Co. v. (C. C. A.)	152
Tennant-Stribling Shoe Co., Miller v. (C. C. A.)	865	United States, Engelhorn v. (C. C.).....	1022
Texas & P. R. Co., Hines v. (C. C. A.)...	157	United States, 581 Diamonds v. (C. C. A.)	556
Thames & Mersey Marine Ins. Co., Soelberg v. (C. C. A.)	23	United States, Francklyn v. (C. C.).....	470
Thompson v. Schenectady R. Co. (C. C.)	634	United States, Kwong Chin Chong v. (C. C.)	383
Thompson, White v. (C. C. A.).....	868	United States, Laverge v. (C. C.).....	481
Thompson Co. v. American Law Book Co. (C. C.)	217	United States, Lorsch v. (C. C.).....	476
Thompson Scenic R. Co. v. Chestnut Hill Casino Co. (C. C.)	359	United States, Miles v. (C. C. A.).....	1019
Thomson-Houston Electric Co. v. Nassau Electric R. Co. (C. C. A.)	354	United States, Powers v. (C. C. A.).....	562
Thomson-Houston Electric Co. v. Wagner Electric Mfg. Co. (C. C.)	178	United States, Schering v. (C. C.).....	472
Toledo Traction Co., Johnson Co. v. (C. C. A.)	885	United States, Schoenemann v. (C. C. A.)	584
Torney, Filhiol v. (C. C.).....	974	United States, Stewart v. (C. C. A.).....	89
Townsend v. Hudson (C. C. A.).....	1021	United States, West v. (C. C.).....	495
Townsend v. Crescent City Transp. Co. (C. C. A.)	118	United States, Wing v. (C. C.).....	479
Trinidad Asphalt Mfg. Co. v. Trinidad Asphalt Refining Co. (C. C. A.)	134	United States, Wing Wo Chong v. (C. C.)	383
Trinidad Asphalt Refining Co., Trinidad Asphalt Mfg. Co. v. (C. C. A.)	134	United States, Yuet Sing v. (C. C.).....	383
Troy White Granite Co. v. Lehtola (C. C. A.)	1021	United States Mailing Tube Co., Huribut v. (C. C.)	188
Turner, In re (D. C.).....	231	Varick Bank of New York, In re (D. C.)..	991
Turner, Sheriff v. (C. C.).....	231	Wabash R. Co., Baltimore & O. R. Co. v. (C. C. A.)	678
Turner, Sheriff v. (C. C.).....	782	Wabash R. Co., Feil v. (C. C.).....	490
Tykeson v. Superior Mfg. Co. (C. C. A.)	1021	Wagner Electric Mfg. Co., Thomson-Houston Electric Co. v. (C. C.)	178
Tynan, Northern Pac. R. Co. v. (C. C. A.)	288	Warren, Hawes v. (C. C.).....	978
Uinta Tunnel Min. & Transp. Co. v. Creede & Cripple Creek Min. & Mill. Co. (C. C. A.)	164	Washington Irr. Co., v. Krutz (C. C. A.)	279
Underwood v. Marshall (C. C. A.).....	1021	Watkins, American Nat. Bank v. (C. C. A.)	545
Underwriter, The (D. C.).....	713	Weddington v. Marshall (C. C. A.).....	1021
Union Special Sewing Mach. Co. v. American Raveller Co. (C. C.)	367	Wellenvoss, Supreme Lodge Knights of Pythias v. (C. C. A.)	671
Union Special Sewing Mach. Co. v. American Raveller Co. (C. C.)	369	West v. United States (C. C.).....	495
Union Terminal R. Co. v. Chicago, B. & Q. R. Co. (C. C.).....	209	Western Assur. Co. of Toronto, Can., Soelberg v. (C. C. A.)	23
Union-Trust Co. v. Stearns (C. C.).....	790	Western Union Tel. Co., National Tel. News Co. v. (C. C. A.)	294
United Blue-Flame Oil Stove Co. v. Glazier (C. C. A.).....	157	Westinghouse Air Brake Co. v. New York Air Brake Co. (C. C. A.)	874
United States v. Adams Exp. Co. (D. C.)	240	Westinghouse Electric & Mfg. Co. v. Orange County Gas & Electric Co. (C. C.)	365
United States v. Alexander (C. C.).....	1015	Weston Electrical Instrument Co. v. Stevens (C. C.)	181
United States v. Brown (C. C.).....	482	White v. Bradley Timber Co. (D. C.)....	989
United States v. Brown (C. C.).....	1022	White v. Thompson (C. C. A.).....	868
United States v. Carcaba (C. C. A.).....	994	Willcox & Gibbs Sewing Mach. Co., Sherbourne v. (C. C.).....	371
United States v. Clawson (D. C.).....	994	William E. Ferguson, The (C. C. A.)....	1022
United States v. E. H. Gato Cigar Co. (C. C. A.)	1022	Wilson v. Parvin (C. C. A.).....	652
United States v. Gentry (C. C. A.).....	70	Wing v. United States (C. C.).....	479
United States v. Lew Poy Dew (D. C.)....	786	Wing Wo Chong v. United States (C. C.)	383
United States v. Littlejohn (C. C.).....	483	Winters, Consolidated Store-Service Co. v. (C. C.)	614
United States v. McCrory (C. C. A.).....	861	Wise, General Electric Co. v. (C. C.).....	922
United States v. McElroy (C. C.).....	478	Witherspoon v. Olcott (C. C. A.).....	175
United States v. McLeod (C. C.).....	416	Wong Him v. Callahan (C. C.).....	381
United States v. Mullins (C. C. A.).....	334	Wood, Casserleigh v. (C. C. A.).....	308
United States v. Nordlinger (C. C.).....	478	Wood, Hudson v. (C. C.).....	764
United States v. Perez (C. C. A.).....	1022	Wood, Taylor Gas Producer Co. v. (C. C.)	966
United States v. Perkins (D. C.).....	384	Wright v. Stanley (C. C. A.).....	330
United States v. Ridenour (D. C.).....	411	Wright's Health Underwear Co., Australian Knitting Co. v. (C. C. A.)	921
Yuet Sing v. United States (C. C.).....	383	York Mfg. Co. v. Rothwell (C. C. A.)....	144
United States v. Schering (C. C.).....	473	Young, George Carroll & Bro. Co. v. (C. C. A.)	576

CASES CITED.

Page		Page
123	Aberfoyle, The, Fed. Cas. No. 16, Abb. Adm. 242	American Net & Twine Co. v. Worthington, 141 U. S. 474, 12 Sup. Ct. 55, 35 L. Ed. 821
528	Abram, In re (D. C.) 103 Fed. 272, 4 Am. Bankr. R. 575	336
834	Academy v. Dickinson, 9 Cush. 544	American Steel Barge Co. v. Cargo of Coal (D. C.) 107 Fed. 964
147	Adams v. Bliss, 16 Vt. 42	123
195	Adams v. Medsker, 25 W. Va. 127	101
399	Adams v. Trust Co., 15 C. C. A. 1, 66 Fed. 617, 620	Amy v. City of Watertown, 130 U. S. 301, 304, 9 Sup. Ct. 530, 531, 32 L. Ed. 946
185	Adee v. Peck (C. C.) 42 Fed. 497	352
593	Etna Life Ins. Co. v. Ward, 140 U. S. 76, 11 Sup. Ct. 720, 35 L. Ed. 371	985, 986
757	Agnes Barton, The, 26 Fed. 542	294
404	Alabama Great Southern R. Co. v. Arnold, 84 Ala. 160, 169, 4 South. 359, 5 Am. St. Rep. 354	743
593	Alabama Great Southern R. Co. v. O'Brien, 16 C. C. A. 216, 69 Fed. 223	750
746	Albany, The, 4 Dill. 439-441, Fed. Cas. No. 131	719
62	Albany Co. v. Stanley, 105 U. S. 305, 26 L. Ed. 1044	893
376, 1005	Alert, The (D. C.) 40 Fed. 836, 9 C. C. A. 390, 61 Fed. 113	893, 973
725	Alexander, The, 1 Dod. 278	734
13, 14	Alexander v. Worthington, 5 Md. 471, 472	128
570	Alexander Folsom, The, 3 C. C. A. 165, 52 Fed. 403	208
616	Alfredo, The, 30 Fed. 842, 32 Fed. 240	976
735	Alfred v. Snow Charming Molly, Vice Adm. Ct. Mass. II, 86	287
789	Alice, The (D. C.) 12 Fed. 923	528
835, 836	Allegheny City v. Reed, 24 Pa. 39	80
498	Allegheny Co. v. Gibson, 90 Pa. 397, 35 Am. Rep. 670	893
556	Allen v. Bank, 20 N. J. Law, 620	138, 143
735	Allen v. Johonnot, Vice Adm. Ct. Mass. I, 26	731, 759
793, 1018	Allen v. Railroad Co., 107 Ga. 838, 33 S. E. 696; 114 U. S. 311, 5 Sup. Ct. 925, 962, 29 L. Ed. 200	625
756	Allianza, The (D. C.) 63 Fed. 726, 732	625
761	Alvira, The (D. C.) 63 Fed. 144	408
595	Ambler v. Choteau, 107 U. S. 556, 1 Sup. Ct. 556, 27 L. Ed. 322	351
188	Ambler v. Whipple, 20 Wall. 546, 22 L. Ed. 403	722
807	American Bell Tel. Co. v. Telegraph Co., 16 C. C. A. 367, 69 Fed. 666	8
985	American Bible Soc. v. Price, 110 U. S. 61, 3 Sup. Ct. 440, 28 L. Ed. 70	863
230	American Eagle, The (D. C.) 54 Fed. 1010	75
226	American Grocer Pub. Ass'n v. Publishing Co., 25 Hun, 398	272
431	American Nat. Bank v. Insurance Co., 32 C. C. A. 275, 89 Fed. 612	733
		454
		711
		314
		570
		762

	Page		Page
Austin v. Tennessee, 179 U. S. 387, 21 Sup. Ct. 132, 45 L. Ed. 224.....	244	Belote v. White, 2 Head, 705, 712.....	827
Averill v. Blackstock (1750) Vice Adm. Ct. R. I.....	735	Bement v. Harrow Co., 186 U. S. 70, 88-91, 22 Sup. Ct. 747, 46 L. Ed. 1058....	924
Avery v. Brown, 31 Conn. 398.....	556	Bemis, In re (D. C.) 104 Fed. 672.....	349
Ayers, Ex parte, 123 U. S. 443, 450, 497, 499-502, 505-507, 8 Sup. Ct. 164, 31 L. Ed. 216.....	791-795	Benefactor, The, 103 U. S. 245, 26 L. Ed. 351.....	1002
Ayres v. Polsdorfer, 45 C. C. A. 24, 105 Fed. 737.....	353	Benjamin v. Stremple, 13 Ill. 466.....	504
Bain, Ex parte, 121 U. S. 1, 7 Sup. Ct. 731, 30 L. Ed. 849.....	511	Bennecke v. Insurance Co., 105 U. S. 355, 26 L. Ed. 990.....	676
Baker v. Kingsland, 10 Paige, 366.....	788	Bennett v. Butterworth, 11 How. 669, 13 L. Ed. 859.....	695, 768
Baker v. Whiting, 1 Story, 232, 233, Fed. Cas. No. 786.....	638	Bennett v. Worthington, 24 Ark. 487, 494	13
Baker-Ricketson & Co., In re (D. C.) 4 Am. Bankr. R. 605, 97 Fed. 489.....	992	Benson Mining & Smelting Co. v. Smelting Co., 145 U. S. 428, 12 Sup. Ct. 877, 36 L. Ed. 762.....	125, 567
Ball v. Trelawny (1641) Cro. Car. 603.....	728	Benzen v. Jeffries (1697) 1 Ld. Raym. 152	729
Ballew v. U. S., 160 U. S. 187, 16 Sup. Ct. 263, 40 L. Ed. 388.....	789	Berrow v. Morris, 10 Beav. 437.....	638
Baltimore & O. R. Co. v. Baugh, 149 U. S. 368, 13 Sup. Ct. 914, 37 L. Ed. 772....	279	Bertha M. Miller, The, 24 C. C. A. 641, 79 Fed. 365, 366.....	753
Baltimore & Ohio Southwestern R. Co. v. Voight, 176 U. S. 498, 505, 20 Sup. Ct. 385, 44 L. Ed. 560.....	231	Bertonneau v. Board, 3 Woods, 177, Fed. Cas. No. 1,361.....	382
Bank of Alabama v. Dalton, 9 How. 522, 528, 13 L. Ed. 242.....	16	Berwind v. Schultz (D. C.) 25 Fed. 912....	754
Bank of the United States v. Macalester, 9 Pa. 475.....	956	Bickley v. Schlag, 46 N. J. Eq. 533, 20 Atl. 250.....	443
Banks v. Ogden, 2 Wall. 57, 17 L. Ed. 818.....	822	Bigelow, Ex parte, 113 U. S. 328, 5 Sup. Ct. 542, 28 L. Ed. 1005.....	624
Bardes v. Bank, 178 U. S. 524, 20 Sup. Ct. 1000, 44 L. Ed. 1175.....	953	Billings v. Smelting Co., 2 C. C. A. 252, 51 Fed. 338.....	311
Bardin v. Lambert (1730-1733) Prov. Cts. Rec. 135.....	736	Bininger, In re, 7 Blatchf. 262, 3 Fed. Cas. 412.....	992
Barkalow v. Totten, 53 N. J. Eq. 573, 32 Atl. 2.....	444	Bird v. Kendall, 62 S. C. 192, 40 S. E. 142.....	713
Barnes v. Underwood, 47 N. Y. 351.....	471	Black Hills Mercantile Co. v. Gardiner, 5 S. D. 246, 58 N. W. 557.....	110
Barnes v. Ward, 67 E. C. L. 392, 398.....	405	Blair, In re (D. C.) 3 Am. Bankr. R. 588, 99 Fed. 76.....	992
Barney v. Keokuk, 91 U. S. 324, 328, 24 L. Ed. 224.....	833	Blantin v. Whitaker, 11 Humph. 313.....	827
Bartlett v. Gates, 118 Fed. 69.....	984	Blease v. Garlington, 92 U. S. 1, 23 L. Ed. 521.....	509
Bartlett v. Slaters, 53 Conn. 102, 22 Atl. 678, 55 Am. Rep. 73.....	693	Bleidorn v. Mining Co., 89 Tenn. 167, 175, 15 S. W. 737.....	827, 832
Bartley v. Yates, 2 Hen. & M. 398.....	195	Blewitt v. Roberts, 1 Craig & P. 274....	693
Bassick Mining Co. v. Schoolfield, 15 Colo. 376, 24 Pac. 1049.....	270	Bloede v. Joseph Bancroft & Sons Co. (C. C.) 98 Fed. 175.....	474
Bates v. Railroad Co., 1 Black, 204, 17 L. Ed. 158.....	829	Bloomer v. Denman, 12 Ill. 240.....	966
Battle & Co. Chemists' Corp. v. U. S., 108 Fed. 216.....	473	Board of Directors of Modesto Irr. Dist. v. Tregoe, 88 Cal. 334, 26 Pac. 237....	538
Beale v. Wilson, 4 Munf. 380.....	195	Bogart v. The John Hay, 17 How. 399, 15 L. Ed. 95.....	744
Beattie v. Wilkinson (C. C.) 36 Fed. 546....	129	Bold Buccleugh, The, 7 Moore P. C. 267....	721
Becker, In re (D. C.) 106 Fed. 54.....	349	Boles v. Smith, 1 Tenn. Cas. 149.....	831
Bedsworth v. Bowman, 104 Mo. 44, 49, 15 S. W. 990.....	16	Bolles Wooden Ware Co. v. U. S., 106 U. S. 432, 1 Sup. Ct. 398, 27 L. Ed. 230....	567
Beinecke v. The Secret (D. C.) 3 Fed. 665	763	Bombay, The (D. C.) 38 Fed. 512, 863....	123, 761
Belding v. Smythe, 138 Mass. 530, 532....	314	Book v. Mining Co. (C. C.) 58 Fed. 106, 113.....	56
Beldon v. Campbell, 6 Exch. 886.....	731	Booth v. Clark, 17 How. 322, 335, 15 L. Ed. 164.....	396
Belfast, The, 7 Wall. 624, 643, 19 L. Ed. 266.....	745	Boreal v. Golden Rose, The, Bee, 131, Fed. Cas. No. 1,658.....	738
Belknap v. Freeman (1752) Vice Adm. Ct. R. I.....	735	Boson v. Sandford, 2 Salk. 440.....	730
Bell v. Allen's Adm'r, 3 Munf. 118.....	195	Boston & A. R. Co. v. City of Boston, 140 Mass. 87, 89, 2 N. E. 943.....	455
Bell v. Locke, 8 Paige, 75, 34 Am. Dec. 371.....	223	Boston & A. R. Co. v. O'Reilly, 158 U. S. 334, 337, 15 Sup. Ct. 830, 39 L. Ed. 1006.....	76
Bellaire v. Railroad Co., 146 U. S. 117, 13 Sup. Ct. 16, 36 L. Ed. 910.....	101	Bosworth v. Railroad Co., 174 U. S. 182, 19 Sup. Ct. 625, 43 L. Ed. 941.....	266
Bellis, In re, 4 Ben. 53, 3 N. B. R. 496, Fed. Cas. No. 1,275.....	511	Bouker v. Randles, 31 N. J. Law, 335....	556

	Page		Page
Boulevard v. Davis, 90 Ala. 207, 8 South. 84, 9 L. R. A. 601.....	397	Bullard v. Insurance Co., 1 Curt. 148, Fed. Cas. No. 2,122.....	29, 31
Bourne v. Crofton, 2 Moll. 318.....	472	Burk, In re, Deady, 425, 3 N. B. R. 296, Fed. Cas. No. 2,156.....	511
Bowers v. Pac. Co. (C. C.) 104 Fed. 887.....	595	Burr v. Duryee, 1 Wall. 573, 17 L. Ed. 650.....	599
Bowman v. Railroad Co., 125 U. S. 465, 8 Sup. Ct. 689, 31 L. Ed. 700.....	242	Burt v. Evory, 133 U. S. 349, 10 Sup. Ct. 394, 33 L. Ed. 647.....	162
Boyd, Ex parte, 105 U. S. 647, 656, 657, 26 L. Ed. 1200.....	769, 770	Burt v. Insurance Co., 106 Mass. 356, 8 Am. Rep. 339.....	454
Boyle v. Zacharie, 6 Pet. 658, 8 L. Ed. 527.....	772	Burt v. Rattle, 31 Ohio St. 116.....	657
Braconsfield, The, 158 U. S. 307, 15 Sup. Ct. 860, 39 L. Ed. 993.....	504	Butchers' Ass'n v. Slaughterhouse Co., 1 Woods, 50, Fed. Cas. No. 2,234.....	354
Bradley v. Railway, 14 Lea, 374.....	276	Butchers' & Drovers' Stock Yards Co. v. Railroad Co., 14 C. C. A. 290, 67 Fed. 35.....	352
Bradlie v. Insurance Co., 12 Pet. 378, 9 L. Ed. 1123.....	31	Buxton v. Snee, 1 Ves. Sr. 154.....	729
Bragdon v. Parkins Campbell Co., 30 C. C. A. 567, 87 Fed. 109.....	575	Byrd v. Badger, 4 Fed. Cas. 942; Fed. Cas. No. 2,266.....	774
Branagan v. Dulaney, 8 Colo. 408, 412, 8 Pac. 669.....	165	Byrd v. Hall, 41 N. Y. 647.....	560
Brantford City, The (D. C.) 29 Fed. 373, 384.....	741	Byrne v. Railroad Co., 9 C. C. A. 666, 677, 61 Fed. 605, 24 L. R. A. 693.....	272, 278
Branyon v. Kay, 33 S. C. 283, 11 S. E. 970.....	713	Cain, The E. L. (D. C.) 45 Fed. 370....	464
Brayton v. Almy (1733) R. I. Super. Ct. Jud.....	736	Cairo v. Zane, 149 U. S. 122, 137, 13 Sup. Ct. 803, 37 L. Ed. 673.....	15
Brent v. Thornton, 45 C. C. A. 214, 106 Fed. 35.....	999	Caldwell v. Brown, 53 Pa. 453.....	277
Brickill v. City of New York (C. C.) 55 Fed. 565, 566.....	807	Calhoun Gold Min. Co. v. Mining Co., 182 U. S. 499, 502, 503, 510, 21 Sup. Ct. 885, 45 L. Ed. 1200.....	125, 166
Bridgeman's Case (1615) Hob. 11; Moore, 918.....	727	Callaghan v. Myers, 128 U. S. 617, 666, 9 Sup. Ct. 177, 32 L. Ed. 547.....	21
Briggs v. Ice Co., 8 C. C. A. 480, 60 Fed. 87.....	358	Camp v. Dixon, 112 Ga. 882, 38 S. E. 71, 52 L. R. A. 755.....	1000
Bristol v. Wilmore, 1 Barn. & C. 514....	560	Campbell v. Campbell, 3 Head, 325.....	828
Broadman v. Thompson, 25 Iowa, 487, 499	314	Campbell v. Lambert, 36 La. Ann. 35, 51 Am. Rep. 1.....	13
Broderick's Will, In re, 21 Wall. 503, 22 L. Ed. 599.....	771	Campbell v. Milliken (C. C.) 119 Fed. 981	983
Bromhall v. The John and Benjamin, Rec. Ct. Ass'ts. Colony of Mass. Bay, 373....	724	Campbell v. Waite, 31 C. C. A. 403, 88 Fed. 102.....	233
Brown, In re, 50 C. C. A. 118, 112 Fed. 49, 7 Am. Bankr. R. 252.....	517, 518, 520	Campbellsville Lumber Co. v. Hubbert, 50 C. C. A. 435, 112 Fed. 718-725.....	216
Brown v. Barry, 3 Dall. 365, 367, 1 L. Ed. 638.....	17	Canal & Claiborne Streets R. Co. v. Hart, 114 U. S. 654, 662, 5 Sup. Ct. 1127, 1131, 29 L. Ed. 226.....	770
Brown v. Bigne, 21 Or. 260, 28 Pac. 11, 14 L. R. A. 745, 28 Am. St. Rep. 752....	314	C. A. Potts & Co. v. Creager, 155 U. S. 597, 608, 15 Sup. Ct. 194, 199, 39 L. Ed. 275, 279.....	891
Brown v. City of Corry (Pa.) 34 Atl. 854	323	Cargo ex Lady Essex, The (D. C.) 39 Fed. 765.....	562
Brown v. Franklyn, Carth. 474.....	719	Carico v. Wilmore (D. C.) 51 Fed. 196....	627
Brown v. Piper, 91 U. S. 37, 23 L. Ed. 200.....	893	Carr v. U. S., 93 U. S. 433, 25 L. Ed. 209	785
Brown v. Railroad Co., 22 N. Y. 191, 194	403	Carrington v. Pratt, 18 How. 63, 67-69, 15 L. Ed. 267.....	744, 750, 752
Brown v. Trousdale, 138 U. S. 389, 11 Sup. Ct. 308, 34 L. Ed. 987.....	101	Carroll, The, 8 Wall. 302, 19 L. Ed. 392	461
Brown v. Webster, 156 U. S. 328, 15 Sup. Ct. 377, 39 L. Ed. 440.....	237	Carstairs v. Stein, 4 Maule & S. 192....	965
Brown v. Wieland (Iowa) 89 N. W. 17....	243	Carver v. Bacigalupi (Cal.) 23 Pac. 363....	57
Brown v. Winnissimmet Co., 11 Allen, 326	711	Carver v. Astor, 4 Pet. 1, 83, 7 L. Ed. 761	825
Browne v. Turner, 176 Mass. 9, 13, 56 N. E. 969.....	456	Carver v. Jackson, 4 Pet. 1, 7 L. Ed. 761	824
Brumelkamp, In re (D. C.) 2 Am. Bankr. R. 318, 95 Fed. 814.....	517	Cary v. White, 5 Brown. Parl. Cas. 325....	731
Brush v. Ware, 15 Pet. 93, 10 L. Ed. 672	177	Case v. Brown, 2 Wall. 320, 17 L. Ed. 817	597
Bryan v. Bernheimer, 181 U. S. 188, 21 Sup. Ct. 557, 45 L. Ed. 814.....	953, 956	Case v. Hall, 36 C. C. A. 259, 94 Fed. 300, 302.....	294
Bucher v. Railroad Co., 125 U. S. 582, 8 Sup. Ct. 974, 31 L. Ed. 795.....	272	Cassell v. Williams, 12 Ill. 387.....	341
Bucklew v. Railroad Co., 64 Iowa, 603, 609, 21 N. W. 103.....	293	Casserleigh v. Wood, 14 Colo. App. 265, 59 Pac. 1024; 119 Fed. 308....	312, 313, 324
Buell, In re, 3 Dill. 116, 120, 121, Fed. Cas. No. 2,102.....	93	Catlett v. Brodie, 9 Wheat. 553, 555, 6 L. Ed. 158.....	150
Bulgaria, The (D. C.) 83 Fed. 312.....	999	Centaur Co. v. Marshall, 38 C. C. A. 413, 97 Fed. 785.....	852

	Page		Page
Central Irr. Dist., In re, 117 Cal. 382, 49 Fac. 354	538	City of Boston v. Richardson, 105 Mass. 351, 357	454
Central Irr. Dist. v. De Lappe, 79 Cal. 351, 21 Pac. 825	538	City of Brockton, The (D. C.) 37 Fed. 897	570
Central Nat. Bank v. Insurance Co., 104 U. S. 54, 26 L. Ed. 693	956	City of Chicago v. Jackson (Ill.) 63 N. E. 1013	665, 668
Central Transp. Co. v. Car Co., 139 U. S. 59, 60, 11 Sup. Ct. 478, 35 L. Ed. 55	711	City of Chicago v. Spoor, 190 Ill. 340, 60 N. E. 540	665
Central Trust Co. v. McGeorge, 151 U. S. 129, 14 Sup. Ct. 286, 38 L. Ed. 98	396	City of Cleveland, The (D. C.) 56 Fed. 729	570
Central Trust Co. v. Railroad Co., 32 C. C. A. 241, 94 Fed. 282	431	City of Cleveland v. Chisholm, 33 C. C. A. 157, 90 Fed. 431	860
Centurion, The (D. C.) 57 Fed. 412; 40 C. C. A. 634, 100 Fed. 663	1005	City of Detroit v. Dean, 106 U. S. 537, 541, 1 Sup. Ct. 560, 27 L. Ed. 300	958, 959
Chadwick v. Clark (1751) Vice Adm. Ct. R. I.	735	City of Detroit v. Railroad Co. (C. C.) 55 Fed. 569, 184 U. S. 368, 382, 22 Sup. Ct. 410, 416, 46 L. Ed. 592	807, 960
Chaffee v. Bell, 20 Wall. 219, 22 L. Ed. 259	745	City of Fergus Falls v. Water Co., 19 C. C. A. 212, 72 Fed. 873	975
Chamberlain v. Mensing (C. C.) 51 Fed. 512	973	City of Huron v. Bank, 30 C. C. A. 38, 43, 86 Fed. 272, 277, 49 L. R. A. 534	15
Champion, The, Fed. Cas. No. 2,583	726	City of Joliet v. Alexander (Ill.) 62 N. E. 861	323
Champion Min. Co. v. Mining Co., 75 Cal. 78, 16 Pac. 513	170	City of Le Mars v. Railroad Co. (C. C.) 48 Fed. 661	101
Chandler v. Siddle, 3 Dill. 477, Fed. Cas. No. 2,594	397	City of Lincoln v. Street Light Co., 8 C. C. A. 253, 59 Fed. 756	76
Chapman, The J. G. (D. C.) 62 Fed. 939	404	City of Little Rock v. U. S., 43 C. C. A. 261, 103 Fed. 418	46
Chappell v. Waterworth, 155 U. S. 102, 15 Sup. Ct. 34, 39 L. Ed. 85	976	City of New Orleans v. Benjamin, 153 U. S. 411, 424, 14 Sup. Ct. 905, 38 L. Ed. 764	960
Charles Carter, The, 4 Cranch, 328, 2 L. Ed. 636	740, 757	City of New Orleans v. U. S., 6 Pet. 662. 717, 9 L. Ed. 573	833
Chatfield v. Wilson, 28 Vt. 49	704	City of New York, In re, Fed. Cas. No. 2- 758	763
Chattanooga Electric R. Co. v. Johnson, 97 Tenn. 667, 37 S. W. 558	275	City of Norwalk, The (D. C.) 55 Fed. 98	721
Chesapeake & Ohio R. Co. v. Dixon, 179 U. S. 131-138, 21 Sup. Ct. 67, 45 L. Ed. 121	211	City of Quincy v. Steel, 120 U. S. 241, 7 Sup. Ct. 520, 30 L. Ed. 624	959
Chew Hing Lung & Co. v. Wise, 176 U. S. 156, 20 Sup. Ct. 320, 44 L. Ed. 412	484	City of St. Louis v. Rutz, 138 U. S. 226, 242, 245, 246, 250, 11 Sup. Ct. 337, 34 L. Ed. 941	822, 832-834
Chicago, M. & St. P. R. Co. v. Ross, 112 U. S. 390, 5 Sup. Ct. 184, 28 L. Ed. 787	278, 279	Clara, The, R. I. Adm. Pap. 29	724
Chicago, St. L. & N. O. R. Co. v. Pounds, 11 Lea. 127	274	Clark v. Smith, 13 Pet. 195, 10 L. Ed. 123	771
Chicago & A. R. Co. v. Ferry Co., 119 U. S. 615, 7 Sup. Ct. 398, 30 L. Ed. 519	693	Cleveland, C., C. & St. L. R. Co. v. Bal- lentine, 28 C. C. A. 572, 84 Fed. 935	575
Chicago & E. R. Co. v. Blake, 116 Ill. 163, 4 N. E. 488	668	Cleveland, C. & C. R. Co. v. Keary, 3 Ohio St. 201	278
Chicago & N. W. R. Co. v. Sayles, 97 U. S. 554, 24 L. Ed. 1053	597	Clinton v. The Hannah (1781) Bee. 419, Fed. Cas. No. 2,898	736
Chicago & N. W. R. Co. v. Schultz, 55 Ill. 421	504	Clyde v. Railroad Co. (C. C.) 59 Fed. 394, 399	21
Child v. Sands (1693) Carth. 294	725	Coal Creek Mining Co. v. Davis, 90 Tenn. 718, 18 S. W. 387	276, 278
Chinn v. Taylor, 64 Tex. 385, 390	346	Coal Creek Min. Co. v. Heck, 15 Lea, 497	831
Chisholm v. Georgia, 2 Dall. 419, 1 L. Ed. 440	790	Cobb v. Cowdery, 40 Vt. 27, 94 Am. Dec. 370	440
Choctaw, O. & G. R. Co. v. Holloway, 52 C. C. A. 263, 114 Fed. 458, 465	75	Cochran v. Wiechers, 119 N. Y. 399, 23 N. E. 803, 7 L. R. A. 553	444
Chopard v. Bayard, 4 Minn. 533 (Gil. 418)	109	Cold Blast Transp. Co. v. Bolt & Nut Co., 52 C. C. A. 25, 114 Fed. 77, 81, 57 L. R. A. 696	13
Christie v. Coke Co. (D. C.) 92 Fed. 3	1005	Colliery Engineer Co. v. Correspondence Schools Co. (C. C.) 94 Fed. 152, 153	220
Church v. Hubbard, 2 Cranch, 187, 2 L. Ed. 249	789	Collins v. Myers, 16 Ohio, 547	109
Church & Dwight Co. v. Russ (C. C.) 99 Fed. 276	223	Colorado Midland R. Co. v. Jones (C. C.) 29 Fed. 193	213
Citizens' Bank v. Farwell, 6 C. C. A. 24, 56 Fed. 570	866	Colton v. Beardsley, 38 Barb. 29, 51	129
City of Albany v. Burke, 11 Wall. 96, 107, 20 L. Ed. 155	208	Columbian, The, 41 C. C. A. 150, 100 Fed. 991	616
City of Beardstown v. Virginia, 76 Ill. 34 17	17		
City of Boston v. Inhabitants of Brookline, 156 Mass. 172, 30 N. E. 611	455		

	Page		Page
Columbia Wire Co. v. Wire Co. (C. C.)	71	Cramer v. Mack (C. C.)	12 Fed. 803, 804,
Fed. 302	924	20 Blatchf. 479	75
Columbus, The, 5 Sawy. 487, Fed. Cas. No. 3,044	761	Crane v. Morris' Lessee, 6 Pet. 598, 8 L. Ed. 514	824
Commercial Advertiser Ass'n v. Haynes, 26 App. Div. 279, 49 N. Y. Supp. 938	223	Crawford v. Neal, 144 U. S. 585, 596, 12 Sup. Ct. 759, 36 L. Ed. 552	21
Commercial & Railroad Bank v. Slocomb, 14 Pet. 60, 10 L. Ed. 354	944	Crockye v. Goods of Cruse, Sel. Pl. II, 81	721
Commissioners of Anderson Co. v. Beal, 113 U. S. 227, 240, 5 Sup. Ct. 433, 28 L. Ed. 966	15	Crommelin v. Minter, 9 Ala. 594	177
Commissioners of Freedman's Sav. & Trust Co. v. Earle, 110 U. S. 710, 4 Sup. Ct. 226, 28 L. Ed. 301	770, 776	Crow Dog, Ex parte, 109 U. S. 556, 3 Sup. Ct. 396, 27 L. Ed. 1030	10
Commonwealth v. Fleming, 130 Pa. 138, 18 Atl. 622, 5 L. R. A. 470, 17 Am. St. Rep. 763	244	Crumpton v. U. S., 138 U. S. 361, 11 Sup. Ct. 355, 34 L. Ed. 958	1015
Conley v. Nailor, 118 U. S. 127, 134, 6 Sup. Ct. 1001, 1005, 30 L. Ed. 112	206	Cuddy v. Clement, 51 C. C. A. 288, 113 Fed. 454, 462	75
Connecticut Mut. Life Ins. Co. v. Spratley, 172 U. S. 603, 19 Sup. Ct. 308, 43 L. Ed. 569	619	Cumberland, The (D. C.)	30 Fed. 449, 455
Conner v. Manachy, Vice Adm. Ct. Mass. I, 51	735	Cumberland Lumber Co. v. Mfg. Co., 57 N. J. Eq. 627, 42 Atl. 585	443
Connihan v. Thompson, 111 Mass. 270	539	Curle v. Barrel, 2 Sneed, 66	833
Conqueror, The, 166 U. S. 110, 133, 17 Sup. Ct. 510, 41 L. Ed. 937	256	Currie v. McKnight (1897) App. Cas. 97	733
Considine v. Insurance Co., 165 Mass. 462, 466, 43 N. E. 201-203	631, 633, 634	Cutter v. Pollock, 7 N. D. 631, 76 N. W. 235	270
Consolidated Rubber Tire Co. v. Finley Rubber Tire Co., 116 Fed. 629	705	Daly v. Webster, 4 C. C. A. 10, 56 Fed. 483	452
Consolidated Store Service Co. v. Herzog (C. C.) 100 Fed. 299; 45 C. C. A. 159, 105 Fed. 985	615	Dana, In re (D. C.)	68 Fed. 886
Consolidated Store Service Co. v. Seybold, 45 C. C. A. 152, 105 Fed. 978	615	D'Arcy v. Ketchum, 11 How. 165, 13 L. Ed. 648	424
Consolidated Store Service Co. v. Siegel Cooper Co. (C. C.) 103 Fed. 489; 46 C. C. A. 599, 107 Fed. 716	614, 615	Darlington v. City of New York, 31 N. Y. 164, 88 Am. Dec. 248	498
Continental Imp. Co. v. Stead, 95 U. S. 166, 24 L. Ed. 403	593	Davenport v. Hannibal, 120 Mo. 150, 25 S. W. 364	16
Continental Nat. Bank v. Weems, 69 Tex. 489, 6 S. W. 802, 5 Am. St. Rep. 85	956	Davenport Nat. Bank v. Board, 123 U. S. 85, 8 Sup. Ct. 73, 31 L. Ed. 94	61
Cook v. Ass'n, 104 Ga. 814, 30 S. E. 911	657	Davidson v. Lanier, 4 Wall. 447, 18 L. Ed. 377	354
Coomes v. Jenkinson (1675) 3 Keb. 398	728	Davidson v. Simmons, 11 Bush, 333, 773-775	775
Coop v. Development Inst. (C. C.) 47 Fed. 899, 901, 48 Fed. 239	385	Davie v. Mining Co., 93 Mich. 491, 53 N. W. 625, 24 L. R. A. 357	13
Corliss v. Pulaski (C. C. A.) 116 Fed. 289	554	Davis v. Billsland, 18 Wall. 659, 661, 21 L. Ed. 969	7
Corning v. Burden, 15 How. 252, 14 L. Ed. 683	597	Davis v. Railroad Co. (C. C.) 25 Fed. 786; 56 Hun, 372, 10 N. Y. Supp. 460; 131 Mass. 258, 41 Am. Rep. 221	410, 712, 805
Corset v. Husely, Comb. 135, Holt. 48	727	Davis v. Schwartz, 155 U. S. 631, 636, 637, 15 Sup. Ct. 237, 39 L. Ed. 289	21
Cory v. Insurance Co., 107 Mass. 140, 147, 9 Am. Rep. 14	31, 32	Davis v. Seeley, 91 Iowa, 583, 586, 60 N. W. 183, 51 Am. St. Rep. 356	404
Cossart v. Lawdley (1688) 3 Mod. 244	727	Davis v. South Carolina, 107 U. S. 597, 2 Sup. Ct. 636, 27 L. Ed. 574	627
Costello v. Burke, 63 Iowa, 361, 19 N. W. 247	825	Davis' Adm'r v. Weibbold, 139 U. S. 507, 11 Sup. Ct. 628, 35 L. Ed. 238	171
Cotting v. Stock Yards Co., 183 U. S. 79, 114, 22 Sup. Ct. 30, 46 L. Ed. 92	793	Dayton v. Borst, 31 N. Y. 435	444
Covell v. Heyman, 111 U. S. 176, 4 Sup. Ct. 355, 28 L. Ed. 390	680	Dayton, W. V. & X. Turnpike Co. v. Coy, 13 Ohio St. 84	13
Cowan v. Iron Co., 83 Va. 547, 3 S. E. 120	201	Dean v. Thatcher, 32 N. J. Law, 470	129
Cowley v. Railroad Co., 159 U. S. 569, 582, 16 Sup. Ct. 127, 131, 40 L. Ed. 263	769	Deaper v. The Black Greyhound (1578) Sel. Pl. II, 155	724
Cox v. Railroad Co., 68 Tex. 226, 4 S. W. 455	175	Decatur v. U. S., Dev. Ct. Cl. 201	388
Cradock's Case (1610) 2 Brownl. & G. 37	727, 728	Decourt v. Sproul, 66 Tex. 371, 1 S. W. 337	176
Cragin v. Lovell, 109 U. S. 194, 3 Sup. Ct. 132, 27 L. Ed. 903	695	Deen v. Wills, 21 Tex. 642	176
		Deeney v. Milling Co. (N. M.) 67 Pac. 724	57
		Deerfield v. Railroad, 144 Mass. 325, 11 N. E. 105	454
		Deery v. Cray, 5 Wall. 795, 807, 808, 18 L. Ed. 653	76, 824
		Deffebach v. Hawke, 115 U. S. 392, 6 Sup. Ct. 95, 29 L. Ed. 423	125
		Delabroche v. Barney (1589) 3 Leon. 232	728

	Page		Page
Delaware, The, 14 Wall. 579, 602, 603, 20 L. Ed. 779	374	Earl of Portsmouth v. Lord Effingham, 1 Ves. Sr. 430	638
De Lovio v. Boit, 2 Gall. 398, 470, Fed. Cas. No. 3,776	743	Easthampton v. Com'rs, 154 Mass. 424, 28 N. E. 298, 13 L. R. A. 157	455, 456
Dennick v. Railroad Co., 103 U. S. 21, 26 L. Ed. 439	273	East Tennessee, V. & G. R. Co. v. Duffield, 12 Lea, 63, 47 Am. Rep. 319	277
Dent v. Ferguson, 132 U. S. 50, 67, 10 Sup. Ct. 13, 33 L. Ed. 242	288	East Tennessee, V. & G. R. Co. v. Grayson, 119 U. S. 240, 244, 7 Sup. Ct. 190, 30 L. Ed. 382	101
Deuell, In re (D. C.) 4 Am. Bankr. R. 60, 100 Fed. 633, 634	1014	East Tennessee, V. & G. R. Co. v. Gurley, 12 Lea, 46	277
Dickinson v. Trust Co. (Sup.) 52 N. Y. Supp. 672	657	Eberly v. Moore, 24 How. 147, 158, 16 L. Ed. 612	511
Diday v. Railroad Co. (C. C.) 107 Fed. 565	213	Eclipse, The, 3 Biss. 99, Fed. Cas. No. 4-268	755
Dimmock v. Chandler, Fitzg. 197	735	Ecorse Transp. Co. v. Earhart (C. C.) 96 Fed. 925	147, 148
Dinglestedt v. U. S., 33 C. C. A. 395, 91 Fed. 112	479	Edgell v. Hart, 9 N. Y. 213, 59 Am. Dec. 532	109
Distilling & Cattle Co. v. Gottschalk Co., 13 C. C. A. 618, 66 Fed. 609	554	Edith, The, Fed. Cas. Nos. 4,282, 4,283; 94 U. S. 518, 520, 24 L. Ed. 167	541, 745
Dockery v. McLellan, 93 Wis. 381, 67 N. W. 733	314	Edwards v. Havill, 14 C. B. 107	731
Dodge v. Woolsey, 18 How. 331, 15 L. Ed. 401	959	Egypt, The (D. C.) 25 Fed. 320	376
Doe v. Mining Co., 17 C. C. A. 190, 196, 70 Fed. 455, 457, 461	57, 77	Eichhold v. Tiffany, 20 Misc. Rep. 680, 46 N. Y. Supp. 534	408
Doggett v. Railroad Co., 99 U. S. 72, 25 L. Ed. 301	17	Eilers v. Boatman, 3 Utah, 159, 2 Pac. 66	56
Donaldson v. Beckett, 2 Brown, Parl. Cas. 129	297	E. L. Cain, The (D. C.) 45 Fed. 370	464
Donaldson v. Farwell, 93 U. S. 631, 23 L. Ed. 993	559	Elder v. Burrus, 6 Humph. 358	829, 833
Donnell v. Insurance Co., 2 Sumn. 366, Fed. Cas. No. 3,987	32	Elizabeth Jones, The, 112 U. S. 514, 5 Sup. Ct. 468, 28 L. Ed. 812	572
Donohoe v. Kettell, 1 Cliff. 135, Fed. Cas. No. 3,980	123	Eliza Jane, The, 1 Spr. 152, Fed. Cas. No. 4,363	755
Dowagiac Mfg. Co. v. Plow Co. (C. A.) 118 Fed. 136	935	Ella, The (D. C.) 84 Fed. 471, 477	753, 755
Draco, The, 2 Sumn. 157, Fed. Cas. No. 4-057	57	Ellen Holgate, The (D. C.) 30 Fed. 125	763
Draper v. Davis, 102 U. S. 370, 26 L. Ed. 121	354	Elliott v. Espenhain, 54 Wis. 231, 11 N. W. 513	147
Draper v. The Black Greyhound, Sel. Pl. I, 155	721	Elliott v. Toepfuer, 23 Sup. Ct. 133, 47 L. Ed. —	1020
Draper v. The Busbye, Sel. Pl. II, p. lxx	724	Ellsworth v. Metheny, 44 C. C. A. 484, 104 Fed. 120, 51 L. R. A. 389	333
Draper v. The Fortune, Sel. Pl. II, 156	721, 724	Emery v. Dunbar, 1 Daly, 408	374
Dravo v. Fabel, 132 U. S. 487, 490, 10 Sup. Ct. 170, 171, 33 L. Ed. 421	207	Emily B. Souder, The, 17 Wall. 666, 667, 670, 671, 21 L. Ed. 683	751, 752
Drew v. Towle, 27 N. H. 412, 59 Am. Dec. 380	556	Emperor, The, Hopk. Judgm. 163, 170	738
Drinkwater v. Spartan, 1 Ware, 145, Fed. Cas. No. 4,085	123	Empire Metallic Bedstead Co., In re (D. C.) 2 Am. Bankr. R. 329; 3 Am. Bankr. R. 575; 95 Fed. 957, 39 C. C. A. 372, 98 Fed. 981	992
Dryfoos v. Wiese, 124 U. S. 37, 8 Sup. Ct. 354, 31 L. Ed. 362	599	Empire Min. Co. v. Tow-Boat Co. (C. C.) 108 Fed. 900	240
Duke v. Harper, 66 Mo. 51, 37 Am. Rep. 314, 315; 2 Mo. App. 1	312, 314, 491	Emsheimer v. City of New Orleans (C. C.) 116 Fed. 893; 186 U. S. 33, 22 Sup. Ct. 770, 46 L. Ed. 1042	1019
Dunbar v. Meyers, 94 U. S. 187, 24 L. Ed. 34	596	Enterprise Min. Co. v. Mining Co., 13 C. C. A. 390, 399, 400, 66 Fed. 200, 209, 210; 167 U. S. 108, 112, 17 Sup. Ct. 762, 42 L. Ed. 96	168
Duncan v. Landis, 45 C. C. A. 666, 106 Fed. 839	990	Ephraim v. Bank, 129 Cal. 589, 62 Pac. 177	270
Dundee, The, 1 Hagg. Adm. 110	721	Equitable B. & L. Ass'n v. Hoffman, 50 S. C. 303, 27 S. E. 692	713
Dunvegan Castle, The, 3 Hagg. Adm. 331	757	Erhardt v. Boaro, 113 U. S. 527, 536, 5 Sup. Ct. 565, 28 L. Ed. 1116	170
Du Prat v. James, 65 Cal. 555, 4 Pac. 562	56	Erie City Iron Works v. Barber, 106 Pa. 125, 51 Am. Rep. 508	436
Durant Min. Co. v. Mining Co., 35 C. C. A. 252, 254, 93 Fed. 166, 168, 169	73	Erwin v. Perego, 35 C. C. A. 482, 485, 93 Fed. 698, 611	170
E. A. Packer, The, 140 U. S. 360, 365, 11 Sup. Ct. 794, 35 L. Ed. 453	566	Espuela Land & Cattle Co. v. Bindle (Tex. Civ. App.) 32 S. W. 582	270
Earl v. Tupper, 45 Vt. 275	441	Evans v. Land Co., 92 Tenn. 355, 21 S. W. 670	828
Earles v. Wells (Wis.) 68 N. W. 964, 59 Am. St. Rep. 886	323		

	Page		Page
Evansville & T. H. R. Co. v. Terre Haute (C. C.) 106 Fed. 545.....	215	Florida R. Co. v. Smith, 21 Wall. 255, 22 L. Ed. 513.....	146
Ewer v. Jones, 6 Mod. 25.....	730	Forney v. Publishing Co. (Sup.) 10 N. Y. Supp. 814.....	223
Fairbank Co. v. Soap Co., 42 C. C. A. 376, 102 Fed. 327.....	223	Ft. Worth City Co. v. Bridge Co., 151 U. S. 294, 14 Sup. Ct. 339, 38 L. Ed. 167..	711
Falconer, In re, 49 C. C. A. 50, 110 Fed. 111.....	340	Fosdick v. Schall, 99 U. S. 235, 25 L. Ed. 339.....	268
Fallbrook Irrigation Dist. v. Bradley, 164 U. S. 112, 17 Sup. Ct. 56, 41 L. Ed. 369	538	Foster v. Gas Co., 32 C. C. A. 560, 90 Fed. 178.....	201
Farmer v. Davies, 1 Term. R. 108.....	731	Foster v. Givens, 14 C. C. A. 625, 67 Fed. 684.....	129
Farmers' Loan & Trust Co. v. Railroad Co. (C. C.) 72 Fed. 26, 31; 31 Or. 237, 48 Pac. 706, 65 Am. St. Rep. 822, 38 L. R. A. 424; 177 U. S. 51, 20 Sup. Ct. 564, 44 L. Ed. 667.....	680	Fourth Nat. Bank v. Francklyn, 120 U. S. 747, 7 Sup. Ct. 757, 30 L. Ed. 825..	444
Farmers' Nat. Bank v. Backus (Minn.) 77 N. W. 142.....	270	Fowler v. Nixon, 7 Heisk. 719, 727.....	828
Farrington v. Tennessee, 95 U. S. 683, 24 L. Ed. 558.....	973	Fowlikes v. Railroad Co., 9 Heisk. 829..	274
Fassett, In re, 142 U. S. 479, 12 Sup. Ct. 295, 35 L. Ed. 1087.....	737	Fox v. Sandford, 4 Sneed, 47, 67 Am. Dec. 587.....	277
Fay v. Cordesman, 109 U. S. 408, 417, 419, 3 Sup. Ct. 236, 27 L. Ed. 979..	163, 164	Fox v. Scard, 33 Beav. 327.....	589
Feibelman v. Packard, 108 U. S. 14, 1 Sup. Ct. 138, 27 L. Ed. 634.....	353	Franklin v. Browne, Vice Adm. Ct. Mass. I, 66.....	735
Felix v. Patrick, 145 U. S. 317, 12 Sup. Ct. 862, 36 L. Ed. 719.....	106	Frazer v. Moffitt (C. C.) 18 Fed. 584....	587
Felton v. Girardy, 43 C. C. A. 439, 104 Fed. 127.....	333	Frazer v. Marsh, 13 East. 238.....	731
Felton v. Spiro, 24 C. C. A. 321 78 Fed. 576.....	965	Frederick R. Stearns & Co. v. Russell, 29 C. C. A. 121, 85 Fed. 218.....	892
Fenn v. Holme, 21 How. 4 ^o , 16 L. Ed. 198.....	768	Freeman v. Asmus, 145 U. S. 239, 12 Sup. Ct. 939, 36 L. Ed. 685.....	160
Ferguson, In re (D. C.) 9 Fed. 429.....	989	Freeman v. Belknap (1754) R. I. Super. Ct. Jud.....	736
Filhiol v. Maurice, 185 J. S. 108, 22 Sup. Ct. 560, 46 L. Ed. 827.....	974	Freeman v. Buckingham, 18 How. 182, 15 L. Ed. 341.....	376
Fink v. U. S., 170 U. S. 584, 18 Sup. Ct. 770, 42 L. Ed. 1153.....	472	Freeman v. Craine (1747) Vice Adm. Ct. R. I.....	735
First Nat. Bank v. Morgan, 132 U. S. 141, 10 Sup. Ct. 37, 33 L. Ed. 282.....	396	Freeman v. Rawson, 5 Ohio St. 1.....	109
Fisher v. Brown, 17 C. C. A. 225, 70 Fed. 570.....	568	Frice, In re (D. C.) 96 Fed. 611, 2 Am. Bankr. R. 674.....	511
Fisk, Ex parte, 113 U. S. 713, 5 Sup. Ct. 724, 28 L. Ed. 1117.....	441	Friedman v. Insurance Co. (C. C.) 101 Fed. 535.....	425
Fisk v. Henarie, 142 U. S. 459, 12 Sup. Ct. 207, 35 L. Ed. 1080.....	10	Frith v. Barker, 2 Johns. 327.....	374
Fitch v. Creighton, 24 How. 159, 16 L. Ed. 596.....	433	Frith v. Cartland, 2 Hen. & M. 417, 420	956
Fitch v. Tudor, Vice Adm. Ct. Mass. I, 39.....	735	Frost v. Knight, L. R. 7 Exch. III.....	971
Fitts v. McGhee, 172 U. S. 516, 524, 528, 529, 530, 19 Sup. Ct. 269, 43 L. Ed. 535.....	795	Frost v. Spitley, 121 U. S. 552, 556, 7 Sup. Ct. 1129, 30 L. Ed. 1010.....	346
Fitzgerald v. Quann, 109 N. Y. 441, 445, 17 N. E. 354.....	17	Fulkerson v. Holmes, 117 U. S. 389, 6 Sup. Ct. 780, 29 L. Ed. 915.....	824
505,000 Feet of Lumber, 12 C. C. A. 628, 65 Fed. 236.....	679	Fuller v. Thorne, Sel. Pl. I, 38.....	721
Flash v. Conn, 109 U. S. 371, 3 Sup. Ct. 263, 27 L. Ed. 966.....	444	Fulton, The Robert, Fed. Cas. No. 11,890 1 Paine, 630.....	464
Fleming v. Lay, 48 C. C. A. 748, 109 Fed. 952.....	1000	Furrer v. Ferris, 145 U. S. 132, 12 Sup. Ct. 821, 36 L. Ed. 649.....	21
Fleming v. The Haddocke, Sel. Pl. II, 191.....	722	F. W. Wheeler, The, 24 C. C. A. 353, 361, 78 Fed. 824.....	855
Fletcher v. La Taile, Vice Adm. Ct. Mass. I, 17.....	735	Gage v. Barnes, 11 Vt. 195.....	440
Florida Cent. & P. R. Co. v. Bell, 176 U. S. 321, 20 Sup. Ct. 399, 44 L. Ed. 486..	976	Gage v. Herring, 107 U. S. 640, 2 Sup. Ct. 819, 27 L. Ed. 601.....	164
		Gale v. Brown, Sel. Pl. I, 55.....	721
		Gallop v. The Willing Mind, Vice Adm. Ct. Mass. I, 180.....	735
		Galveston, H. & S. A. Ry. Co. v. Garrett, 73 Tex. 262, 13 S. W. 62, 15 Am. St. Rep. 781.....	292
		Gambrell v. Steele, 55 Tex. 582.....	176
		Gamewell Fire Alarm Tel. Co. v. City of New York (C. C.) 31 Fed. 312.....	385
		Gandolfi v. U. S., 20 C. C. A. 652, 74 Fed. 549.....	153
		Gardner v. Herz, 118 U. S. 180, 6 Sup. Ct. 1027, 30 L. Ed. 158.....	596

CASES CITED.

xix

	Page		Page
Gardner v. McEwen, 19 N. Y. 123.....	109	Graham, In re, 2 Biss. 449, Fed. Cas. No. 5,660	342
Gardner v. Railroad Co., 150 U. S. 349, 361, 14 Sup. Ct. 140, 37 L. Ed. 1107....	293	Graham v. Bayne, 18 How. 60, 63, 15 L. Ed. 265	566
Gardner v. The New Jersey, 1 Pet. Adm. 223, Fed. Cas. No. 5,233.....	739	Grand Trunk R. Co. v. Ives, 144 U. S. 408, 417, 12 Sup. Ct. 679, 36 L. Ed. 485	293
Garnham v. Bennett, 2 Strange, 816.....	730	Grand Trunk R. Co. v. Richardson, 91 U. S. 454, 23 L. Ed. 356.....	979
Gaylord, In re, 50 C. C. A. 415, 112 Fed. 668, 669	409-411	Grant v. Insurance Co., 121 U. S. 105, 7 Sup. Ct. 841, 30 L. Ed. 905.....	432
Gemma, The (1899) Prob. Div. 285.....	721, 758	Grant v. Raymond, 6 Pet. 218, 241, 8 L. Ed. 376	924
General Burnside, The (C. C.) 3 Fed. 228	733, 751	Grant v. Walter, 148 U. S. 553, 13 Sup. Ct. 699, 37 L. Ed. 552.....	162
General Electric Co. v. Electric Co. (C. C.) 106 Fed. 503.....	925, 926	Grape Creek Coal Co. v. Trust Co., 12 C. C. A. 350, 353, 63 Fed. 891, 894.....	77
General Smith, The, 4 Wheat. 438, 4 L. Ed. 609	715, 741, 743-745, 747-749	Grapeshot, The, 9 Wall. 129, 136-138, 19 L. Ed. 651.....	749, 751, 753
Gentry v. U. S., 41 C. C. A. 185, 101 Fed. 51	568	Graves, In re (D. C.) 24 Fed. 550.....	511
George Dumois, The, 15 C. C. A. 675, 68 Fed. 926	760	Graves v. Corbin, 132 U. S. 571, 10 Sup. Ct. 196, 33 L. Ed. 462.....	101
George Farwell, The, 43 C. C. A. 373, 103 Fed. 882	753, 756	Gray v. Rollo, 18 Wall. 629, 21 L. Ed. 927	147
George T. Kemp, The, 2 Low. 477, 481, Fed. Cas. No. 5,341.....	739, 753	Greeley v. Winsor, 1 S. D. 117, 618, 45 N. W. 325; 48 S. W. 214; 36 Am. St. Rep. 720	110
George W. Roby, The, 49 C. C. A. 481, 495, 111 Fed. 601.....	859, 861	Green v. Inhabitants of Chelsea, 24 Pick. 71, 79	454
Gere v. Murphy, 6 Minn. 305 (Gil. 213)...	109	Green v. Railroad Co., 112 Ga. 849, 38 S. E. 81	1018
Germanic, The (D. C.) 107 Fed. 294.....	377	Green Bay & M. R. Co. v. Steamboat Co., 107 U. S. 98, 2 Sup. Ct. 221, 27 L. Ed. 413	710
Gerrish v. Ship Sarah, Vice Adm. Ct. Mass. I, 123	735	Greenberg, In re (D. C.) 5 Am. Bankr. R. 840, 106 Fed. 496.....	1014
Gibbs v. The Christiana, Vice Adm. Ct. Mass. II, 110.....	735	Greene v. Mumford, 4 R. I. 313.....	527
Gilman v. Ketcham, 84 Wis. 60, 54 N. W. 395, 23 L. R. A. 52, 36 Am. St. Rep. 89	397	Greenway v. Barker (1613) Godb. 260, 719, 725	725
Gilmer v. Higley, 110 U. S. 47, 50, 3 Sup. Ct. 471, 28 L. Ed. 62.....	76	Greenwood v. Railroad Co., 105 U. S. 13, 26 L. Ed. 961.....	959
Gird v. Oil Co. (C. C.) 60 Fed. 531.....	57	Gretson v. The Pink Expectation, Schin- chinke Owner, pp. 178, 378.....	724
Gleeson v. Mining Co., 13 Nev. 442, 462, Fed. 823	223	Griggs v. Fleckenstein, 14 Minn. 81 (Gil. 62), 100 Am. Dec. 199.....	946
Glide, The, 167 U. S. 606, 17 Sup. Ct. 930, 42 L. Ed. 296.....	757	Grimball v. Ross, T. U. P. Charit. 175.....	410
Globe Mut. Life Ins. Co. v. Wolff, 95 U. S. 326, 24 L. Ed. 387.....	675	Griswold v. Gebbie, 126 Pa. 363, 17 Atl. 673, 12 Am. St. Rep. 878.....	437
Godfrey's Case, Latch. 11.....	727	Griswold v. Sheldon, 4 N. Y. 581.....	109
Godkin v. Monahan, 27 C. C. A. 410, 83 Fed. 116	374	Griswold v. Wagner, 15 C. C. A. 525, 68 Fed. 494	893
Goggin v. Railroad Co., Thomp. Tenn. Cas. 142	276	Grosvenor v. Lane, 2 Atk. 180.....	472
Goldey v. Morning News, 156 U. S. 518, 523, 15 Sup. Ct. 559, 30 L. Ed. 517....	424	Guardian Permanent Ben. Bldg. Soc., In re. 23 Ch. Div. 440, 453.....	656, 658, 661
Gonner v. Pattyson, Sel. Pl. II, 106.....	722	Gullett v. O'Connor, 54 Tex. 408.....	176
Goodlander Mill Co. v. Oil Co., 11 C. C. A. 253, 63 Fed. 400.....	575	Gunnison Co. v. E. H. Rollins & Sons, 173 U. S. 255, 19 Sup. Ct. 390, 43 L. Ed. 689	47
Goodwin v. Thompson, 15 Lea, 209, 54 Am. Rep. 410.....	829, 833, 834	Gustafson v. Rustemeyer, 70 Conn. 132, 39 Atl. 104, 39 L. R. A. 644, 66 Am. St. Rep. 92	458
Goodyear Tire & Rubber Co. v. Wheel Co., 116 Fed. 363.....	705	Gustafson v. Wind, 62 Iowa, 281, 284, 17 N. W. 523.....	404
Gordon, Ex parte, 104 U. S. 515, 26 L. Ed. 814	737	Gustavia, The, 1 Blatchf. & H. 189, Fed. Cas. No. 5,876.....	751
Gormley v. Clark, 134 U. S. 348, 10 Sup. Ct. 554, 33 L. Ed. 909.....	768	Guthrie v. Railroad Co., 11 Lea, 372, 47 Am. Rep. 286.....	277
Governor, The, 1 Abb. Adm. 108, Fed. Cas. No. 5,645	571	Hadji, The (C. C.) 20 Fed. 875.....	376
Governor v. McMannus' Adm'rs, 11 Humph. 152	273	Hagan v. Campbell, 8 Port. 9, 33 Am. Dec. 267	834
Gowen v. Harley, 6 C. C. A. 190, 56 Fed. 973	625	Hague v. Ahrens, 3 C. C. A. 426, 53 Fed. 58	142
Gracie v. Palmer, 8 Wheat. 605, 5 L. Ed. 696	119	Hale v. Coffin (C. C.) 114 Fed. 567.....	255
Graffam v. Burgess, 117 U. S. 180, 195, 6 Sup. Ct. 686, 29 L. Ed. 839.....	511		

	Page		Page
Haley v. Railroad Co., 7 Baxt. 239-242...	275	Hembree v. Dawson, 18 Or. 474, 23 Pac.	133
Hall v. Lanning, 91 U. S. 160, 23 L. Ed.	271	264	826
Hall v. Mining Co., Morr Min. R. (3d Ed.)	424	Henderson v. Galloway, 8 Humph. 692...	826
282	168	Henderson's Distilled Spirits, 14 Wall. 44-	559, 561
Hall v. Railroad Co., Thomp. Tenn. Cas.	204	59, 20 L. Ed. 815.....	559, 561
Hall v. Woodward, 30 S. C. 564, 9 S. E.	684	Hennessey v. Budde (C. C.) 82 Fed. 541,	21
1039, 9 L. R. A. 801.....	709	542	21
Hamilton v. Insurance Co., 137 U. S. 370,	385, 11 Sup. Ct. 133, 34 L. Ed. 703.....	Hennessy v. Woolworth, 128 U. S. 438,	288
489	489	442, 9 Sup. Ct. 109, 32 L. Ed. 500.....	288
Hamlin v. Railroad Co., 24 C. C. A. 271,	658	Henrich Bjorn, The, 11 App. Cas. 270, 282	729
78 Fed. 664, 36 L. R. A. 826.....	658	Henry v. Insurance Co. (C. C.) 45 Fed.	638
Hanaw v. Bailey, 83 Mich. 24, 46 N. W.	142	303	638
Hancock v. Holbrook, 119 U. S. 586, 7	985	Herring v. Irrigation Dist., 95 Fed. 705,	538
Sup. Ct. 341, 30 L. Ed. 538.....	985	715	538
Handly v. Greene, 15 Barb. 602.....	788	Herrington v. Williams, 31 Tex. 448, 460	346
Hanger v. Abbott, 6 Wall. 532, 18 L. Ed.	939	Hersey, The, 3 Hagg. Adm. 404.....	757
939	9	Hershberger v. Blewett (C. C.) 55 Fed. 170	807
Hans v. Louisiana, 134 U. S. 1, 10 Sup.	791	Heyward v. Williams, 48 S. C. 564, 26 S.	709
Ct. 504, 33 L. Ed. 842.....	791	E. 797	709
Harbour Co. v. Xenos, 11 C. B. (N. S.) 152	971	Higgins v. Keuffel, 140 U. S. 435, 11 Sup.	220
Hardin v. Boyd, 113 U. S. 756, 764, 5 Sup.	511	Ct. 733, 35 L. Ed. 470.....	220
Ct. 771, 28 L. Ed. 1141.....	511	Higgins v. Murray, 73 N. Y. 252.....	244
Hardman v. Brett (C. C.) 37 Fed. 803, 2 L.	504	Hill, In re, 2 Ben. 136, 1 N. B. R. 275,	511
R. A. 173.....	504	Fed. Cas. No. 6,482.....	511
Harkrader v. Wadley, 172 U. S. 148, 19	679	Hill v. Ship Elizabeth, Vice Adm. Ct.	735
Sup. Ct. 119, 43 L. Ed. 399.....	679	Mass. I. 43.....	735
Harness v. Oil Co., 49 W. Va. 232, 38 S.	200	Hills v. Chicago, 60 Ill. 86.....	17
E. 662	200	Hilsendegen v. Scheich, 55 Mich. 468, 21	142
Harris v. Haynes, 34 Vt. 220.....	440	N. W. 894.....	142
Harrison v. Hughes, 110 Fed. 545.....	997	Hiram R. Dixon, The (D. C.) 33 Fed. 297	757
Harrison v. Stubbarde, Sel. Pl. I. 62.....	721	Hirsch, In re (D. C.) 96 Fed. 468, 471, 2	511
Hartford Fire Ins. Co. v. Railroad Co.,	175 U. S. 91, 98, 20 Sup. Ct. 33, 44 L.	Am. Bankr. R. 715, 718.....	511
75 U. S. 91, 98, 20 Sup. Ct. 33, 44 L.	84	Hixon, In re (D. C.) 93 Fed. 440, 1 Am.	511
84	230	Bankr. R. 610.....	511
Hartman v. Warren, 22 C. C. A. 30, 76	125	Hixson v. Burson, 54 Ohio St. 470, 43 N.	47
Fed. 157	125	E. 1000	47
Hartrant v. Wiegmann, 121 U. S. 609, 7	587	Hoadley v. Watson, 45 Vt. 289, 292, 12	441
Sup. Ct. 1240, 30 L. Ed. 1012.....	587	Am. Rep. 197.....	404, 441
Harvey v. Hackney, 35 S. C. 366, 14 S. E.	822	Hoare v. Clement (1684) 2 Show. 338.....	728
822	709	Hobbs v. Beach, 180 U. S. 383, 394, 21	185
Hastorf v. Supply Co. (D. C.) 110 Fed.	669	Sup. Ct. 409, 45 L. Ed. 586.....	971
669	1005	Hochster v. De La Tour, 2 El. & Bl. 678	971
Hatfield v. Grimstead, 29 N. C. 139.....	835	Hodge v. Palms, 15 C. C. A. 220, 68 Fed.	824
Hauswirth v. Butcher, 4 Mont. 308, 1 Pac.	714	61	824
714	56	Hodge v. Town of Bennington, 43 Vt. 450	440
Havana, The (D. C.) 54 Fed. 201, 35 C.	753, 755	Hodskins v. Sloop Argyle, Vice Adm. Ct.	724, 735
C. A. 148, 92 Fed. 1007.....	753, 755	Mass. I, 114.....	724, 735
Hawes v. Oakland, 104 U. S. 450, 26 L.	958, 959	Hogden v. Golder, 75 Me. 293.....	556
Ed. 827	958, 959	Hohmann v. City of Chicago, 140 Ill. 226,	667
Hawkins v. Massie, 62 Mo. 552, 553.....	75	29 N. E. 671.....	667
Haws v. Mining Co., 160 U. S. 303, 318, 16	56	Holberg, The, 157 U. S. 68, 15 Sup. Ct.	592
Sup. Ct. 282, 40 L. Ed. 436.....	276	480, 39 L. Ed. 620.....	592
Haynes v. Railroad, 3 Cold. 222.....	208	Holbert v. Edens, 5 Lea, 204, 208, 40 Am.	829
Hayward v. Bank, 96 U. S. 611, 618, 24 L.	753, 763	Rep. 26	829
Ed. 855	753, 763	Holland v. Challen, 110 U. S. 15, 3 Sup.	771
H. B. Foster, The, 3 Ware, 165, Fed. Cas.	138	Ct. 495, 28 L. Ed. 52.....	771
No. 6,291	138	Hollister v. Mfg. Co., 113 U. S. 59, 5 Sup.	596
H. D. Williams Cooperage Co. v. Scofield	704	Ct. 717, 28 L. Ed. 901.....	596
(C. C. A.) 115 Fed. 119, 121.....	704	Holman, In re (D. C.) 92 Fed. 512, 1 Am.	511
Heath v. Unwin, 15 Sim. 552.....	443	Bankr. R. 600, 605.....	511
Hebberd v. Cattle Co., 55 N. J. Eq. 18, 36	143, 69 Am. Dec. 308.....	Holmes v. Goldsmith, 147 U. S. 150, 13	556
Atl. 122	31	Sup. Ct. 288, 37 L. Ed. 118.....	556
Hebner v. Insurance Co., 10 Gray, 131,	464	Holston v. Iron Co., 95 Tenn. 521, 32 S.	275
143, 69 Am. Dec. 308.....	408	W. 486	275
Heidritter v. Oilcloth Co., 112 U. S. 294,	464	Hood v. McNaughton, 54 N. J. Law, 425,	444
304, 5 Sup. Ct. 135, 28 L. Ed. 729.....	408	24 Atl. 497.....	444
Heinemann v. Heard, 62 N. Y. 448.....	408	Hood v. Railroad Co., 22 Conn. 1.....	712
	408	Hoofnagle v. Anderson, 7 Wheat. 212, 5 L.	177
	408	Ed. 437	177
	408	Horn v. Lockhart, 17 Wall. 570, 21 L. Ed.	949
	408	657	949

	Page		Page
Horner v. U. S., 143 U. S. 207, 12 Sup. Ct. 407, 36 L. Ed. 126.....	93	James, In re (C. C.) 18 Fed. 853.....	93
Horton v. Williams, 21 Minn. 187, 190, 109, Ct. 834, 31 L. Ed. 759.....	110	James v. Campbell, 104 U. S. 356, 26 L. Ed. 786.....	784
Hoskins v. Fisher, 125 U. S. 221, 8 Sup. Ct. 834, 31 L. Ed. 759.....	159	Jas. A. Dumont, The (D. C.) 34 Fed. 428	999
Howe v. Jones, 66 Iowa, 156, 23 N. W. 376	270	Jefferies v. Land Co., 134 U. S. 178, 188, 10 Sup. Ct. 518, 33 L. Ed. 872.....	822, 833
Hubbard v. Godfrey, 100 Tenn. 150, 156, 161, 47 S. W. 81.....	828	Jenkins v. Freyer, 4 Paige, 51.....	472
Hudson v. Parker, 156 U. S. 277, 15 Sup. Ct. 450, 39 L. Ed. 424.....	150	Jenks' Adm'r v. Stapp, 3 C. C. A. 244, 52 Fed. 641.....	554
Huey's Appeal, 29 Pa. 219.....	342	Jennie B. Gilkey, The (C. C.) 19 Fed. 127	751
Hungerford v. Railroad Co., 41 Minn. 444, 43 N. W. 324.....	292	Jennings v. Whitaker, 4 T. B. Mon. 50....	177
Hunter v. Hallett, 1 Edw. Ch. 388.....	472	J. E. Rumbell, The, 148 U. S. 1, 11, 13 Sup. Ct. 498, 37 L. Ed. 345....	745, 751, 762
Hunter v. Hemphill, 6 Mo. 119.....	177	Jerusalem, The, 2 Gall. 345, 348-350, Fed. Cas. No. 7,294.....	740
Hunter v. U. S., 5 Pet. 173, 182, 8 L. Ed. 86.....	511	Jewel v. Neidy, 61 Iowa, 299, 300, 16 N. W. 141.....	314
Huntingdon v. Palmer, 104 U. S. 482, 26 L. Ed. 833.....	959	J. G. Chapman, The (D. C.) 62 Fed. 939....	464
Huntington v. Saunders, 120 U. S. 80, 7 Sup. Ct. 356, 30 L. Ed. 580.....	776	J. L. Mott Iron Works v. Clow, 27 C. C. A. 250, 82 Fed. 316.....	298
Hurd v. City of Elizabeth, 41 N. J. Law, 1	397	Johann Friederich, The, 1 W. Rob. Adm. 37.....	721
Hutter v. Broome, 114 Fed. 655.....	190	John, The, 3 C. Rob. Adm. 288.....	725
Hutton v. Arnett, 51 Ill. 193.....	504	John of Alen, The, Sel. Pl. I. 53.....	721
Hyde v. Stone, 20 How. 170, 175, 15 L. Ed. 874.....	423	Johns v. Simons, 2 Q. B. 425.....	731, 759
Illinois v. Fletcher (C. C.) 22 Fed. 778....	628	Johns v. Wilson, 180 U. S. 440, 21 Sup. Ct. 445, 45 L. Ed. 613.....	771
Illinois Cent. R. Co. v. Illinois, 146 U. S. 387, 13 Sup. Ct. 110, 36 L. Ed. 1018....	836	Johnson v. Eldridge, 49 Tex. 507.....	176
Illinois Cent. R. Co. v. Spence, 93 Tenn. 174, 23 S. W. 211, 42 Am. St. Rep. 907	271, 278	Johnson v. Kelly, 67 Vt. 386, 31 Ath. 849	147
India, The (D. C.) 14 Fed. 476; (C. C.) 16 Fed. 262.....	763	Johnson v. Monell, 41 N. Y. 655.....	560
Industrial Mfg. Co. v. Sewing Machine Co., 50 C. C. A. 387, 112 Fed. 535.....	371	Johnson v. Murray, 12 Lea. 109, 116.....	516
Inhabitants of Cheshire v. Reservoir Co., 119 Mass. 356, 357.....	456	Johnson v. Railroad Co., 33 N. Y. 610, 612, 88 Am. Dec. 116; 49 N. Y. 455, 462....	16, 811, 812
Inhabitants of Deerfield v. Arms, 17 Pick. 43, 28 Am. Dec. 276.....	832	Johnson v. Shippen, 2 Ld. Raym. 982....	723, 727
Inhabitants of Millbury v. Canal Co., 25 Mass. 473.....	456	Johnson v. Southern Pac. Co. (C. C. A.) 117 Fed. 462.....	13, 16-18
Inhabitants of Springfield v. Railroad Co., 4 Cush. 63.....	455	Johnson v. Towsley, 13 Wall. 78, 20 L. Ed. 485.....	117
Inland & S. Coasting Co. v. Tolson, 139 U. S. 551, 557, 11 Sup. Ct. 653, 35 L. Ed. 270.....	293	Johnston v. City of Pittsburg (C. C.) 106 Fed. 753.....	318
Insurance Co. of North America v. Trust Co., 17 C. C. A. 616, 71 Fed. 88.....	554	Joice v. Cockrill, 35 C. C. A. 38, 92 Fed. 838.....	147
International Bank v. Sherman, 101 U. S. 403, 405, 406, 25 L. Ed. 866.....	511, 953	Jones v. Littlefield, 3 Yerg. 133.....	273
Investor Pub. Co. v. Dobinson (C. C.) 82 Fed. 56.....	225	Jones v. McMasters, 20 How. 8-22, 15 L. Ed. 805.....	695
Iris, The, 40 C. C. A. 301, 100 Fed. 104....	757	Jones v. Sherman, 56 Miss. 560.....	825
Iron Chief, The, 11 C. C. A. 196, 63 Fed. 239.....	572	Jones v. Soulard, 24 How. 41, 16 L. Ed. 604.....	822
Iron Silver Min. Co. v. Campbell, 135 U. S. 286, 301, 10 Sup. Ct. 763, 34 L. Ed. 155.....	168, 170	Jones v. The Ratler, Taney, 456, Fed. Cas. No. 7,490.....	753
Isaac May, The (D. C.) 21 Fed. 687.....	755	Jones v. Yeager, 2 Dill. 64, Fed. Cas. No. 7,510.....	277
Ives v. Sargent, 119 U. S. 652, 662, 7 Sup. Ct. 436, 30 L. Ed. 544.....	160	Jonty Jenks, The (D. C.) 54 Fed. 1021....	230
Jackson v. Cooley, 8 Johns. 128.....	825	Joyce v. O'Toole, 6 Bush, 32.....	775
Jackson v. Vernon, 1 H. Bl. 114.....	732	Jupiter Min. Co. v. Mining Co. (C. C.) 11 Fed. 666, 667, 676, 7 Sawy. 96.....	56, 170
Jacksonville, M., P. R. & Nav. Co. v. Hooper, 160 U. S. 514, 16 Sup. Ct. 379, 40 L. Ed. 515.....	711	Justin v. Ballam (1702) 1 Salk. 34.....	729
Jaffray v. Raab, 72 Iowa, 335, 33 N. W. 337.....	133	Kahl v. Love, 37 N. J. Law, 5.....	575
		Kaiser, In re (D. C.) 99 Fed. 689, 3 Am. Bankr. R. 767.....	511
		Kalorama, The, 10 Wall. 204, 212, 213, 214, 19 L. Ed. 941.....	746, 755
		Kate, The, 164 U. S. 458, 465-470, 17 Sup. Ct. 135, 138, 139, 41 L. Ed. 512....	755, 760-762
		Kearney v. Cruikshank, 117 N. Y. 95, 22 N. E. 580.....	693

	Page		Page
Keller v. Ashford, 133 U. S. 610, 10 Sup. Ct. 494, 33 L. Ed. 667.....	695, 769	Lee v. Lee, 4 De Gex, M. & G. 222, 223; 9 Hare App. 91; 10 Hare App. 72.....	638
Kennedy v. Gibson, 8 Wall. 498, 506, 19 L. Ed. 476.....	10	Lee v. Stahl, 9 Colo. 208, 210, 11 Pac. 77	169
Kennedy v. Hazelton, 126 U. S. 667, 9 Sup. Ct. 202, 32 L. Ed. 576.....	187	Leffingwell v. Warren, 2 Black, 599, 17 L. Ed. 261.....	272
Kennerty v. Phosphate Co., 21 S. C. 242, 53 Am. Rep. 669.....	708	Lehew v. Brummell (Mo.) 15 S. W. 765, 11 L. R. A. 828, 23 Am. St. Rep. 895..	382
Kentucky Railroad Tax Cases, 115 U. S. 321, 6 Sup. Ct. 57, 29 L. Ed. 414.....	63	Leigh v. Burley (1610) Owen, 122.....	726
Keyser v. Farr, 105 U. S. 265, 26 L. Ed. 1025.....	354	Leisey v. Hardin, 135 U. S. 100, 10 Sup. Ct. 681, 34 L. Ed. 128.....	242
Keystone Bridge Co. v. Iron Co., 95 U. S. 274, 24 L. Ed. 344.....	884	Leland v. Medora, 2 Woodb. & M. 92, Fed. Cas. No. 8,237.....	540
Kilby v. Wilson, Ryan & M. 178.....	560	Leonard v. Wiseman, 31 Md. 201, 204....	17
Kimball, The, 3 Wall. 37, 45, 46, 18 L. Ed. 50.....	373	Lesser Cotton Co. v. Yates, 69 Ark. 396, 63 S. W. 997.....	619
Kimberly v. Arms, 129 U. S. 512, 9 Sup. Ct. 355, 32 L. Ed. 764.....	21	Levi v. Legg, 23 S. C. 283.....	973
Kimbrough v. Benton, 3 Humph. 129.....	828	Levy v. Burley, 2 Summ. 355, Fed. Cas. No. 8,300.....	789
King v. McAndrews, 50 C. C. A. 29, 32, 111 Fed. 860, 863.....	166	Lewensohn, In re (D. C.) 98 Fed. 576....	248
Kinne v. Webb, 4 C. C. A. 170, 54 Fed. 34	106	Lewis v. Orpheus, Fed. Cas. No. 8,330, 3 Ware, 143.....	464
Kirby v. Railroad Co. (C. C.) 106 Fed. 551	215	Libby v. Hopkins, 104 U. S. 303, 26 L. Ed. 769.....	956
Kirwan v. Murphy, 28 C. C. A. 348, 83 Fed. 275-280.....	785	Lillard v. Ass'n (C. C.) 87 Fed. 213.....	220
Knickerbocker v. Mining Co., 172 Ill. 535, 50 N. E. 330, 64 Am. St. Rep. 54; 67 Ill. App. 291.....	270	Lilly v. Railroad Co., 32 S. C. 142, 10 S. E. 932.....	708, 709
Knickerbocker Life Ins. Co. v. Pendleton, 115 U. S. 339, 6 Sup. Ct. 74, 29 L. Ed. 432.....	354	Lister v. Baxter (1726) 2 Strange, 695....	727
Knott v. Worsted Mills, 179 U. S. 69, 21 Sup. Ct. 30, 45 L. Ed. 90.....	377	Littleton v. James, Vice Adm. Ct. Mass. I, 10.....	724
Knowles v. Gaslight Co., 19 Wall. 58, 22 L. Ed. 70.....	424	Livingston v. Kane, 3 Johns. Ch. 224....	589
Knox Co. v. Morton, 15 C. C. A. 671, 673, 68 Fed. 787, 789.....	16	Livingston v. McDonald, 21 Iowa, 160, 89 Am. Dec. 563.....	783
Knoxville Iron Co. v. Dobson, 7 Lea, 367	277	Livingstone, The, 51 C. C. A. 560, 113 Fed. 879.....	572
Koechl v. U. S., 33 C. C. A. 363, 91 Fed. 110.....	473	Loague v. Railroad, 91 Tenn. 458, 19 S. W. 430.....	275
Kohn v. McNulta, 147 U. S. 238, 13 Sup. Ct. 298, 37 L. Ed. 150.....	292	Lochiel, The, 2 W. Rob. Adm. 45.....	759
Kountze v. Hotel Co., 107 U. S. 378, 2 Sup. Ct. 911, 27 L. Ed. 609.....	431	Lockhart v. Van Alstyne, 31 Mich. 76, 18 Am. Rep. 156.....	662
Kutcher v. Love, 19 Colo. 542, 546, 36 Pac. 152.....	312	Loeb v. Trustees, 179 U. S. 472, 488, 21 Sup. Ct. 174, 45 L. Ed. 230.....	47
Lafferty v. Jelley, 22 Ind. 471.....	314	Logan, In re, 4 Am. Bankr. R. 525, 102 Fed. 876.....	409
Lafferty v. Whitesides' Lessee, 1 Swan, 123-128.....	828	Logan v. Bodkin, Vice Adm. Ct. Mass. I, 59.....	735
Lake Co. v. Rollins, 130 U. S. 662, 670, 9 Sup. Ct. 651, 652, 32 L. Ed. 1060.....	16, 17	Long, In re, 3 N. B. R. 66, Fed. Cas. No. 8,477.....	511
Lamoille County Nat. Bank v. Hunt, 72 Vt. 357, 47 Atl. 1078.....	147	Lorillard Co. v. Peper Co., 30 C. C. A. 496, 86 Fed. 956.....	852
Lancaster Co. v. Collins, 115 U. S. 222, 6 Sup. Ct. 33, 29 L. Ed. 373.....	556	Lottawanna, The, 20 Wall. 201, 219, 22 L. Ed. 259; 21 Wall. 558, 559, 571, 572, 574, 578, 582, 593, 22 L. Ed. 654.....	755
Langley v. Ross, 55 Mich. 163, 20 N. W. 886.....	142	540, 737, 742, 745, 746, 749, 752, 755	677
Lansing v. Russel, 3 Barb. Ch. 325.....	738	Loubat v. LeRoy, 40 Hun, 546-549.....	677
Lanyon Zinc Co. v. Brown (C. C. A.) 115 Fed. 150.....	918	Louisiana v. City of New Orleans, 109 U. S. 285, 3 Sup. Ct. 211, 27 L. Ed. 936....	498
Last Chance Min. Co. v. Mining Co., 9 C. C. A. 613, 621, 623, 61 Fed. 557, 565....	170	Louisville Trust Co. v. Comingor, 184 U. S. 18, 22 Sup. Ct. 293, 46 L. Ed. 413..	953, 955
Latimer v. Investment Co. (C. C.) 81 Fed. 776.....	659	Louisville & N. R. Co. v. Bowler, 9 Heisk. 866.....	276, 277
Latting v. Latting, 4 Sandf. Ch. 31.....	472	Louisville & N. R. Co. v. Burke, 6 Cold. 45, 49.....	273
League v. Rogan, 59 Tex. 430.....	176	Louisville & N. R. Co. v. Lahr, 86 Tenn. 340, 6 S. W. 663.....	276, 278
Leary v. U. S., 14 Wall. 607, 20 L. Ed. 756.....	119, 229	Louisville & N. R. Co. v. Miller, 43 C. C. A. 436, 104 Fed. 124.....	333
		Louisville & N. R. Co. v. Wangelin, 132 U. S. 599, 10 Sup. Ct. 203, 33 L. Ed. 473.....	211

	Page		Page
Lovel Mfg. Co. v. Cary, 147 U. S. 623, 633, 13 Sup. Ct. 472, 37 L. Ed. 307...	891, 893	Marion S. Harris, The, 29 C. C. A. 428, 85 Fed. 798	755
Lucia B. Ives, The, Fed. Cas. No. 8,590...	763	Market City Market House & Hall Ass'n v. Kearns, 103 Pa. 403, 407, 408	577
Ludgate Hill, The (D. C.) 21 Fed. 431...	755	Marks v. Van Egghen, 30 C. C. A. 208, 85 Fed. 853	971
Lulu, The, 10 Wall. 192, 197, 200, 203, 19 L. Ed. 906	751, 753, 755	Martin v. Green (1665) 1 Keb. 730	719
Lys v. Lee, 4 De Gex, M. & G. 219	638	Martin v. Hunter's Lessee, 1 Wheat' 304, 335, 4 L. Ed. 97	741
McAllister v. The Sam Kirkman, Fed. Cas. No. 8658	751	Martin v. Nance, 3 Head, 649	829, 833
McAnulty v. Bingaman, 6 How. (Miss.) 382	867	Martin v. Railroad Co., 94 Cal. 326, 329, 29 Pac. 645	292
McCaffery v. Mfg. Co. (R. I.) 50 Atl. 651, 55 L. R. A. 822	575	Marx, In re, 4 Am. Bankr. R. 521, 102 Fed. 676	409
McCarty v. Railroad Co., 160 U. S. 110, 16 Sup. Ct. 240, 40 L. Ed. 358	884	Mary Morgan, The (D. C.) 28 Fed. 196	755
McCaslan v. Latimer, 17 S. C. 128	971	Mason v. Trippe, Sel. Pl. II, 117	722
McCaulley v. City of Philadelphia, 103 Fed. 661; 116 Fed. 438	580	Masterson v. Herndon, 10 Wall. 416, 19 L. Ed. 953	353
McChord v. Railroad Co., 22 Sup. Ct. 165, 170, 46 L. Ed. 239	960	Mast, Foos & Co. v. Mfg. Co., 177 U. S. 485, 20 Sup. Ct. 708, 44 L. Ed. 856	596, 892
McCormick, In re (D. C.) 3 Am. Bankr. R. 340, 97 Fed. 566, 567	1014	Matheson & Co. v. U. S., 18 C. C. A. 143, 71 Fed. 394	336
McCormick Harvesting Mach. Co. v. Ault- man, Miller & Co., 16 C. C. A. 259, 69 Fed. 371	163	Matthews, In re, 109 Fed. 603, 610	7
McDonnell v. Jordan, 178 U. S. 229, 20 Sup. Ct. 886, 44 L. Ed. 1048	10	Maud Carter, The (D. C.) 29 Fed. 156	747
McDowell v. McMurria, 107 Ga. 812, 33 S. E. 709, 73 Am. St. Rep. 155	338, 339, 341	Maury County B. & L. Ass'n v. Cowley (Tenn.) 52 S. W. 312, 313	656, 661
McGaughey v. Brown, 46 Ark. 37	16	Maxcy v. Court, 72 Ill. 207	15
McHardy v. Wadsworth, 8 Mich. 349	147	Maxwell v. State, 40 Md. 293	13, 14
McIver v. Ragan, 2 Wheat. 25, 29, 4 L. Ed. 175	16	Maxwell v. Wardroper, Mor. Dec. 6266	732
Mack v. Sloteman (C. C.) 21 Fed. 109, 117	151	Mayer, In re (D. C.) 3 Am. Bankr. R. 533, 98 Fed. 839, 841	1014
McKinley Creek Min. Co. v. Mining Co., 183 U. S. 563, 22 Sup. Ct. 84, 46 L. Ed. 331	55	Mayor, etc., of New Orleans v. U. S., 10 Pet. 662, 717, 9 L. Ed. 573	822
McKinnon v. Palen, 62 Minn. 188, 64 N. W. 387	147	Mayor, etc., of New York v. Transporta- tion Co. (C. C.) 24 Fed. 817	101
McLean v. Mayo (D. C.) 113 Fed. 106, 7 Am. Bankr. R. 115	528	Mayo's Estate, In re, 60 S. C. 401, 411, 38 S. E. 634, 54 L. R. A. 660	403
McLendon v. Railroad Co., 54 Ga. 293	1018	Meguire v. Corwine, 101 U. S. 108, 111, 25 L. Ed. 899	286
McMasters v. Burnett, 92 Ky. 358, 17 S. W. 1021	147	Mellen v. Iron Works, 131 U. S. 352, 367, 9 Sup. Ct. 781, 33 L. Ed. 178	132
McMurray's Heirs v. Erie, 59 Pa. 226	129	Memphis & L. R. R. Co. v. Cariley, 39 Ark. 246	16
Madden v. Lancaster Co., 12 C. C. A. 566, 573, 65 Fed. 188	15	Menendez v. Holt, 128 U. S. 514, 9 Sup. Ct. 143, 32 L. Ed. 526	224
Maddison v. Alderson, 52 Law J. Q. B. 737	23	Menetone v. Gibbous, 3 Term. R. 267	729
Madera Irr. Dist., In re, 92 Cal. 296, 28 Pac. 272, 675, 14 L. R. A. 755, 27 Am. St. Rep. 106	538	Merchant, The, Abb. Adm. 1, Fed. Cas. No. 9,434	721
Maggie J. Smith, The, 123 U. S. 349, 8 Sup. Ct. 159, 31 L. Ed. 175	572	Merchant Adventurers Co. v. The Eliza- beth George, Sel. Pl. II, 150	722
Magoffin v. Ass'n (Minn.) 91 N. W. 1115	619	Merchants' Mut. Ins. Co. v. Baring, 20 Wall. 159, 163, 164, 22 L. Ed. 250	751, 755
Maguire v. Card, 21 How. 248, 251, 16 L. Ed. 118	745	Merchants' Nat. Bank v. McLeod, 38 Ohio St. 174	397
Mahn v. Harwood, 112 U. S. 354, 363, 6 Sup. Ct. 451, 28 L. Ed. 665	160	Merrill v. Yeomans, 94 U. S. 568, 24 L. Ed. 235	884
Mahoney Min. Co. v. Bank, 104 U. S. 192, 26 L. Ed. 707	687	Merritt v. Steel Barge Co., 24 C. C. A. 530; 79 Fed. 228	680
Mann v. Appel (C. C.) 31 Fed. 378	770	Merryweather v. Mountford (1676) 3 Keb. 552	728
Manns v. Land Co., 153 U. S. 273, 14 Sup. Ct. 820, 38 L. Ed. 714	836	Mesaba, The (D. C.) 111 Fed. 215	570
Marcardier v. Insurance Co., 8 Cranch, 39, 48, 3 L. Ed. 481	31, 32	Metallic Extraction Co. v. Brown, 43 C. C. A. 568, 104 Fed. 345	918, 921
Mariners' Case, The, 8 Mod. 379	730	Metcalf v. Prescott (Mont.) 25 Pac. 1038	57
		Metcalf Bros. & Co. v. Barker, 23 Sup. Ct. 67, 47 L. Ed. —	770, 870, 992
		Metropolitan West Side El. R. Co. v. Stick- ney, 150 Ill. 362, 37 N. E. 1098, 26 L. R. A. 773	667, 670

	Page		Page
Mexia v. Oliver, 148 U. S. 664, 673, 13 Sup. Ct. 754, 37 L. Ed. 602.....	76	Morrow Shoe Mfg. Co. v. Shoe Co., 6 C. C. A. 515, 57 Fed. 693, 24 L. R. A. 417.....	560
Mexican Nat. R. Co. v. Davidson, 157 U. S. 201, 208, 15 Sup. Ct. 563, 39 L. Ed. 672.....	213	Moses v. U. S., 166 U. S. 571, 17 Sup. Ct. 682, 41 L. Ed. 1119.....	789
Miles v. Ass'n (C. C.) 95 Fed. 919.....	397	Moss v. Gibbs, 10 Heisk. 283.....	821, 823
Miller v. Brass Co., 104 U. S. 350, 26 L. Ed. 783.....	160	Mott v. Mott, 5 Vt. 111.....	147
Miller v. Crigler, 83 Mo. App. 395.....	147	Moyer, In re (D. C.) 93 Fed. 188.....	989
Miller v. Mfg. Co., 151 U. S. 199, 14 Sup. Ct. 310, 38 L. Ed. 121.....	931, 935	Mudd, In re (D. C.) 105 Fed. 348, 5 Am. Bankr. R. 242.....	511
Miller v. Moss, 65 Tex. 182.....	176	Mueller v. Nugent, 184 U. S. 1, 22 Sup. Ct. 269, 46 L. Ed. 405.....	953-955, 1014
Miller v. Railroad Co., 5 C. C. A. 134, 55 Fed. 366.....	556	Mugler v. Kansas, 123 U. S. 623, 8 Sup. Ct. 273, 31 L. Ed. 205.....	785
Miller v. Ratterman, 47 Ohio St. 141, 24 N. E. 496.....	658	Muller v. Tool Co., 23 C. C. A. 357, 77 Fed. 621.....	163
Milligan & Higgins Glue Co. v. Upton, 97 U. S. 3, 24 L. Ed. 985.....	595	Mulry v. Norton, 100 N. Y. 426, 3 N. E. 581, 53 Am. Rep. 206.....	831
Minchen v. Hart, 18 C. C. A. 570, 72 Fed. 294.....	554	Munhall v. Boedecker, 44 Ill. App. 131.....	657
Mississippi & M. R. Co. v. Ward, 2 Black, 485, 17 L. Ed. 311.....	318, 1016	Municipal Signal Co. v. Mfg. Co., 46 C. C. A. 270, 107 Fed. 284; 97 Fed. 810, 813.....	191
Mississippi & R. R. Boom Co. v. Patterson, 98 U. S. 403, 25 L. Ed. 206.....	213	Murray v. Insurance Co. (Sup.) 25 N. Y. Supp. 414, 416.....	33
Missouri v. Kentucky, 11 Wall. 395, 401, 20 L. Ed. 116.....	821	Murray v. Scott, 9 App. Cas. 519, 523, 656, 658, 661.....	834
Missouri, K. & T. R. Co. v. Bagley, 60 Kan. 424, 431, 56 Pac. 759.....	13	Murry v. Sermon, 8 N. C. 56.....	687
Missouri, K. & T. R. Co. v. Elliott (C. C.) 56 Fed. 773.....	433	Mutual Reserve Fund Life Ass'n v. Hamlin, 139 U. S. 297, 11 Sup. Ct. 614, 35 L. Ed. 167.....	687
Missouri, K. & T. R. Co. v. McCann, 174 U. S. 586, 19 Sup. Ct. 755, 43 L. Ed. 1093.....	272	Mutual Reserve Fund Life Ass'n v. Philips, 103 Fed. 515.....	773
Missouri Pac. R. Co. v. Railroad Co. (C. C.) 31 Fed. 862; 33 Fed. 803, 806.....	527	Myers v. Railroad Co., 91 N. W. 1076.....	214
Mitchell v. Harmony, 13 How. 115, 14 L. Ed. 75.....	784	Myers v. Spooner, 55 Cal. 257.....	57
M. Kalbfleisch, The (D. C.) 59 Fed. 198.....	999	Myers v. Sternheim, 38 C. C. A. 345, 97 Fed. 625.....	294
Modern Woodmen of America v. Jameson, 48 Kan. 718, 30 Pac. 460.....	675	Naddo v. Bardon, 2 C. C. A. 335, 51 Fed. 493.....	106
Moffatt v. The Mermaid (1752) Vice Adm. Ct. R. I.....	735	Nashville, C. & St. L. R. Co. v. Handman, 13 Lea, 423.....	276, 278
Monsoon, The, Fed. Cas. No. 9,716.....	763	Nashville, C. & St. L. R. Co. v. McConnell (C. C.) 82 Fed. 65.....	948
Montagu v. Bank (C. C.) 81 Fed. 602.....	956	Nashville & C. R. Co. v. Carroll, 6 Heisk. 347.....	276, 277
Montana Ore-Purchasing Co. v. Mining Co., 29 C. C. A. 462, 85 Fed. 867; 35 C. C. A. 1, 5, 93 Fed. 274, 279.....	533, 976	Nashville & C. R. Co. v. Elliott, 1 Cold. 611, 616, 78 Am. Dec. 506.....	276, 277
Montanye v. Montanye, 29 App. Div. 377, 51 N. Y. Supp. 538.....	694	Nashville & C. R. Co. v. Prince, 2 Heisk. 580.....	273
Moore v. Edgefield (C. C.) 32 Fed. 493.....	237	Nashville & C. R. Co. v. Smith, 9 Lea, 470-474.....	273, 274
Moore v. Robbins, 96 U. S. 530, 24 L. Ed. 848.....	117	Nashville, C. & St. L. R. Co. v. Wheless, 10 Lea, 741, 748, 43 Am. Rep. 317.....	276
Moore v. Bank, 104 U. S. 625, 630, 26 L. Ed. 870.....	76	Natchez, The, 24 C. C. A. 49, 78 Fed. 183.....	999
Moran v. Sturges, 154 U. S. 256, 274, 284, 14 Sup. Ct. 1019, 38 L. Ed. 981.....	462, 463	National Acc. Soc. v. Spiro, 37 C. C. A. 388, 94 Fed. 750.....	788
Morgan, In re (D. C.) 101 Fed. 982, 4 Am. Bankr. R. 402.....	511	National Harrow Co. v. Quick (C. C.) 67 Fed. 131.....	924
Morgan v. Des Moines, 8 C. C. A. 569, 60 Fed. 208.....	16	National Life Ins. Co. v. Board, 10 C. C. A. 637, 644, 62 Fed. 778, 784.....	15
Morgenson v. Milling Co., 11 Colo. 176, 179, 17 Pac. 513.....	169	National Masonic Acc. Ass'n v. Shryock, 20 C. C. A. 3, 11, 73 Fed. 774, 781.....	75
Morley Sewing-Mach. Co. v. Lancaster, 129 U. S. 273, 9 Sup. Ct. 299, 32 L. Ed. 715.....	931	National Telegraph News Co. v. Telegraph Co., 119 Fed. 294.....	308
Morning Light, The, 2 Wall. 550, 17 L. Ed. 862.....	858	Neagle, In re, 135 U. S. 1, 10 Sup. Ct. 658, 34 L. Ed. 55.....	234
Morris v. Dock Co., 91 Ill. App. 437.....	147	Nebraska v. Iowa, 143 U. S. 359, 361, 367, 12 Sup. Ct. 396, 36 L. Ed. 186.....	822, 823, 833, 834
Morris v. U. S., 174 U. S. 196, 236, 19 Sup. Ct. 649, 43 L. Ed. 946.....	835-837		
Morrison v. Jewell, 34 Me. 146.....	536		
Morrison v. Searight, 4 Baxt. 479.....	638		

	Page		Page
Necker v. Harvey, 49 Mich. 517, 14 N. W. 503	575	Oakes v. Hill, 31 Mass. 442	739
Neill v. The Francis (D. C.) 21 Fed. 921	763	Ocean City Ass'n v. Shriver, 64 N. J. Law, 550, 46 Atl. 690, 51 L. R. A. 425	829
Nelson, In re (D. C.) 98 Fed. 76	990	Officium Domini v. Pirate, Goods, Sel. Pl. II, 84, 91	722
Nelson v. James, Vice Adm. Ct. Mass. I, 102	735	Officium Domini v. The Eugenius, Sel. Pl. II, 99	722
Neptune, The, 3 Knapp, 94, 115	726	O'Hara v. Railroad Co., 22 C. C. A. 512, 76 Fed. 718	788
Nestor, The, 1 Sumn. 73, 75, 79, Fed. Cas. No. 10,126	752	O'Hara v. The Mary, Bee, 100 Fed. Cas. No. 10,467	738
Newcomb's Ex'rs v. Newcomb, 13 Bush. 544, 26 Am. Rep. 222	129	Ohio, The, 33 C. C. A. 667, 671, 91 Fed. 547, 551	861
Newell v. People, 7 N. Y. 9, 97	17	Ohio v. Thomas, 173 U. S. 276-284, 19 Sup. Ct. 453, 43 L. Ed. 699	235
New England Mut. Marine Ins. Co. v. Dunham, 11 Wall. 10, 20 L. Ed. 90	734	O'Keson v. Barclay, 2 Pen. & W. 531	969
New England R. Co. v. Conroy, 175 U. S. 323, 20 Sup. Ct. 85, 44 L. Ed. 181	279	Oliver v. City of Worcester, 102 Mass. 499, 3 Am. Rep. 485	454
New Hampshire Land Co. v. Tilton (C. C.) 29 Fed. 764	806	Oliver v. The Industry (1744) Vice Adm. Ct. R. I.	735
New Jersey C. R. Co. v. Mills, 113 U. S. 249, 5 Sup. Ct. 456, 28 L. Ed. 949	101	Oliver Jordan, The, Fed. Cas. No. 10,503, 2 Curt. 414	464
New Jersey Steam Nav. Co. v. Bank, 6 How. 344, 391, 422, 12 L. Ed. 465	745	Olmsted v. Keyes, 85 N. Y. 602	471
	734, 744, 745	Olsen v. Lumber Co., 40 C. C. A. 427, 100 Fed. 384	79
Newport, The (D. C.) 107 Fed. 744	753	Olympia, The, 9 C. C. A. 393, 61 Fed. 120	855
Newton v. Wooley (C. C.) 105 Fed. 541, 544	287	Omaha & R. V. R. Co. v. Brady, 39 Neb. 27, 50, 57 N. W. 767	314
New York, The, 175 U. S. 187, 270, 20 Sup. Ct. 67, 44 L. Ed. 126	461	O'Neal v. Manning, 48 Tex. 403	176
New York Air-Brake Co. v. Air-Brake Co., 16 C. C. A. 371, 69 Fed. 715	874	O'Niell v. Vermont, 144 U. S. 323, 12 Sup. Ct. 693, 36 L. Ed. 450	244
New York Ferry Co. v. Moore, 18 Abb. N. C. 106, 102 N. Y. 667, 6 N. E. 293	410	Oregon Imp. Co. v. Coal Co., 132 U. S. 215, 10 Sup. Ct. 54, 33 L. Ed. 341	159
New York Guaranty & Indemnity Co. v. Water Co., 107 U. S. 214, 2 Sup. Ct. 279, 27 L. Ed. 484	767	O'Reilly v. Edrington, 96 U. S. 724, 24 L. Ed. 659	150
New York & N. E. R. Co. v. Hyde, 5 C. C. A. 461, 56 Fed. 188	873	O'Reilly v. Morse, 15 How. 62, 119, 14 L. Ed. 601	174
New York & P. R. S. S. Co., In re, 155 U. S. 523, 15 Sup. Ct. 183, 39 L. Ed. 246	1005	Origet v. U. S., 125 U. S. 240, 8 Sup. Ct. 846, 31 L. Ed. 743	560
Niblock v. Alexander (C. C.) 44 Fed. 306	985	Osborn v. Bank, 9 Wheat. 738, 871, 6 L. Ed. 204	793
Nichols v. Steel Co., 137 N. Y. 471, 33 N. E. 561	972	Oscanyan v. Arms Co., 103 U. S. 261, 275, 26 L. Ed. 539	286
Nickerson v. Nickerson, 127 U. S. 668, 675, 8 Sup. Ct. 1355, 32 L. Ed. 314	288	Oswego Tp. v. Insurance Co., 17 C. C. A. 77, 70 Fed. 225	76
Noble v. Adams, 7 Taunt. 59	560	Otis v. Rio Grande, The, 1 Woods, 279, Fed. Cas. No. 10,613	129
Noble v. Railroad Co., 147 U. S. 165, 13 Sup. Ct. 271, 37 L. Ed. 123	127, 786	Owensboro Nat. Bank v. Owensboro, 173 U. S. 664, 19 Sup. Ct. 537, 43 L. Ed. 850	60
Nofire v. U. S., 164 U. S. 660, 17 Sup. Ct. 212, 41 L. Ed. 588	128		
Nonce v. Railroad Co. (C. C.) 33 Fed. 429	964	Pacific Bank v. Fruit & Land Co., 124 Cal. 525, 57 Pac. 462	270
Noonan v. Railroad Co. (C. C.) 68 Fed. 1	944	Paddock v. Insurance Co., 104 Mass. 521, 534	31
Norfolk Southern R. Co. v. Barnes, 104 N. C. 25, 10 S. E. 83, 5 L. R. A. 611	244	Page v. The Blessing of God, Sel. Pl. II, p. lxx	724
Norris v. Jackson, 9 Wall. 125, 19 L. Ed. 608	505, 566	Palliser, In re, 136 U. S. 257, 10 Sup. Ct. 1034, 34 L. Ed. 514	93
North v. The Eagle, Bee, 78, Fed. Cas. No. 10,309	738	Palmer v. McMahon, 133 U. S. 669, 10 Sup. Ct. 324, 33 L. Ed. 772	63
Northern Pac. R. Co. v. Paine, 119 U. S. 561, 7 Sup. Ct. 323, 30 L. Ed. 513	696	Palmer Co. v. Ferrill, 17 Pick. 58	667, 668
North Noonday Min. Co. v. Mining Co. (C. C.) 1 Fed. 522, 531, 6 Sawy. 299, 11 Fed. 125, 6 Sawy. 299, 310	56, 170	Parker v. Hulme, 1 Fish. Pat. Cas. 44, Fed. Cas. No. 10,740	704
North Pacific, The, 40 C. C. A. 510, 100 Fed. 490	755, 763	Parmenter Mfg. Co. v. Stoever, 38 C. C. A. 200, 97 Fed. 330	989, 990
Northwestern Transp. Co. v. Insurance Co. (C. C.) 24 Fed. 171, 175	29	Partington v. Attorney General, L. R. 14 H. L. 100	336
Norwegian S. S. Co. v. Washington, 6 C. C. A. 313, 57 Fed. 224	763	Patapsco, The, 13 Wall. 329, 333, 334, 20 L. Ed. 696	752
Nugent v. Ass'n, 172 Mass. 278, 52 N. E. 440	633		

	Page		Page
Patapsco Ins. Co. v. Southgate, 5 Pet. 604, 619, 8 L. Ed. 243	30	Phoenix Mut. Life Ins. Co. v. Raddin, 120 U. S. 196, 7 Sup. Ct. 500, 30 L. Ed. 644	675
Patten v. Stacy (1716) Prov. Cts. Rec. 143	736	Pickard v. Kleis, 56 Mich. 604, 23 N. W. 329	142
Patterson v. Winn, 11 Wheat. 380, 6 L. Ed. 500	177	Pierce v. Railroad Co., 173 U. S. 1, 19 Sup. Ct. 335, 43 L. Ed. 591	973
Paxson v. Cunningham, 11 C. C. A. 111, 63 Fed. 132	464, 465	Pilgren v. State, 71 Ala. 368	244
Payne v. Hook, 7 Wall. 425, 19 L. Ed. 260	773	Pillsbury v. Flour Mills Co., 12 C. C. A. 432, 64 Fed. 841	851
Peak v. Ellicott, 30 Kan. 161, 162, 1 Pac. 501, 46 Am. Rep. 90	955, 956	Pim v. Wait (C. C.) 32 Fed. 741	964
Pearson v. Chace, 10 R. I. 455	693	Pirate, The (D. C.) 32 Fed. 486	763
Pearson v. Yewdall, 95 U. S. 294, 24 L. Ed. 436	354	Pirie v. Trust Co., 182 U. S. 438, 21 Sup. Ct. 906, 45 L. Ed. 1171	534
Peck v. Heurich, 167 U. S. 624, 629, 630, 17 Sup. Ct. 927, 42 L. Ed. 302	76, 314	Pittsburgh, C. & St. L. R. Co. v. Bridge Co., 131 U. S. 385, 9 Sup. Ct. 770, 33 L. Ed. 157	711
Peck v. Tie Co., 116 Fed. 273	279	Place v. Langworthy, 13 Wis. 629, 80 Am. Dec. 758	109
Peele v. Insurance Co., 3 Mason, 27, Fed. Cas. No. 10,905	31	Pleasants v. Faut, 22 Wall. 116, 121, 22 L. Ed. 780	332, 964
Peggy, The (1752) Vice Adm. Ct. R. I.	735	Plummer v. Mining Co. (C. C.) 55 Fed. 755	964
Pemberton v. Goffe, Vice Adm. Ct. Mass. I. 63	735	Poindexter v. Greenhow, 114 U. S. 270, 5 Sup. Ct. 903, 962, 29 L. Ed. 185	793
Pemberton v. Ship Mauzsell, Vice Adm. Ct. Mass. I. 62	724	Polk v. Henderson, 9 Yerg. 312	828
Pendleton v. Hooper, 87 Ga. 108, 13 S. E. 313, 27 Am. St. Rep. 227	339, 341	Polk v. Wendal, 9 Cranch, 87, 3 L. Ed. 665	177
Pennyroy v. McConaughy, 140 U. S. 1, 11 Sup. Ct. 699, 35 L. Ed. 363	794	Pollard v. Shively, 5 Colo. 309	56
Pennyroy v. Neff, 95 U. S. 714, 24 L. Ed. 565	424	Pollard's Heirs v. Files, 3 Ala. 47	177
Pennsylvania Co., Ex parte, 137 U. S. 451, 11 Sup. Ct. 141, 34 L. Ed. 738	986	Pope Mfg. Co. v. Gormully, 144 U. S. 224, 233, 12 Sup. Ct. 632, 36 L. Ed. 414	287
Pennsylvania R. Co. v. Safety Truck Co., 110 U. S. 490, 4 Sup. Ct. 220, 28 L. Ed. 222	892	Posey v. James, 7 Lea, 98	822, 823, 829, 833
People v. Badlam, 57 Cal. 601	61	Posey v. Scoville (C. C.) 10 Fed. 140	123
People v. Gallagher, 93 N. Y. 438, 45 Am. Rep. 232	382	Post v. Ass'n, 97 Tenn. 408, 37 S. W. 216, 34 L. R. A. 201	659, 660
People v. Potter, 47 N. Y. 375	17	Potter v. The Brigantine Greyhound (1747) Vice Adm. Ct. R. I.	736
People v. School Board, 161 N. Y. 598, 56 N. E. 81, 48 L. R. A. 113	382	Potter v. Washburn, 13 Vt. 558, 37 Am. Dec. 615	825
People v. Weaver, 100 U. S. 543, 25 L. Ed. 705	60	Powers v. Railroad Co., 169 U. S. 92, 18 Sup. Ct. 264, 42 L. Ed. 673	215
People's Ferry Co. v. Beers, 20 How. 393, 401, 402, 15 L. Ed. 961	745, 751, 754	Pratt v. Reed, 19 How. 359, 361, 15 L. Ed. 660	750, 751, 754
Peoria, P. & J. R. Co. v. McIntire, 39 Ill. 298	504	Preston v. Hunter, 15 C. C. A. 148, 67 Fed. 996	57
Perkins v. Wylie (1725-1730) Prov. Cts. Rec. 338	736	Prince v. City of Quincy (Ill.) 21 N. E. 768	323
Pervanger v. Surety Co. (Miss.) 32 South. 909	619	Prince v. Crocker, 166 Mass. 347, 362, 363, 44 N. E. 446, 32 L. R. A. 610	456
Petroleum Co. v. Mfg. Co., 89 Tenn. 381, 18 S. W. 65	201	Prince v. Railroad Co. (C. C.) 98 Fed. 1-3	213
Pettibone v. U. S., 148 U. S. 197, 13 Sup. Ct. 542, 37 L. Ed. 419	419	Pritchard v. The Lady Horatio, Bee, 167, Fed. Cas. No. 11,438	738
Peyroux v. Howard, 7 Pet. 324, 341, 344, 345, 8 L. Ed. 700	744, 745, 753	Proctor v. Railroad Co., 64 S. C. 492, 42 S. E. 427	709
Phelps v. Ass'n, 50 C. C. A. 339, 112 Fed. 456	773	Proprietors of Mt. Hope Cemetery v. City of Boston, 158 Mass. 509, 519, 33 N. E. 695, 35 Am. St. Rep. 515	454
Phenix Ins. Co., Ex parte, 118 U. S. 610, 7 Sup. Ct. 25, 30 L. Ed. 274	737	Prospect, The, 3 Blatchf. 526, Fed. Cas. No. 11,443	753
Philadelphia, The, 21 C. C. A. 501, 75 Fed. 684	760	Providence Tool Co. v. Norris, 2 Wall. 45, 56, 17 L. Ed. 868	286
Philip Schneider Brewing Co. v. Machine Co., 23 C. C. A. 89, 77 Fed. 138	151	Provident Sav. Life Assur. Soc. v. Hadley, 102 Fed. 856, 860, 861	633
Phillips v. City of Detroit, 111 U. S. 604, 4 Sup. Ct. 580, 28 L. Ed. 532	595	Province v. Ass'n, 104 Tenn. 458, 58 S. W. 265	660
Phillips v. Cooper, 50 Miss. 722	867	Public Bath No. 13, The (D. C.) 61 Fed. 692	1005
Phoenix Ins. Co. v. Copelin, 9 Wall. 461, 19 L. Ed. 739	29, 566	Pullman's Palace Car Co. v. Transportation Co., 171 U. S. 138, 18 Sup. Ct. 808, 43 L. Ed. 108	807

	Page		Page
Pulsifer v. Hotchkiss, 12 Conn. 234.....	556	Rope Work Co. v. Crosses (1761) Mor. Dec. 6268	732
Pulsifer v. Walley, Vice Adm. Ct. Mass. I, 48	735	Rosser, In re, 41 C. C. A. 497, 101 Fed. 562	953
Purvine, In re, 37 C. C. A. 446, 96 Fed. 192	953, 1014	Rothschild v. U. S., 179 U. S. 468, 21 Sup. Ct. 197, 45 L. Ed. 277	1022
Radford v. Folsom, 55 Iowa, 276, 7 N. W. 604	132	Rowell v. Lindsay, 113 U. S. 97, 103, 5 Sup. Ct. 507, 28 L. Ed. 906.....	163, 599
Ragsdale v. Railroad Co., 3 Baxt. 426 ..	277	Royall, Ex parte, 117 U. S. 241, 6 Sup. Ct. 734, 29 L. Ed. 868.....	233
Rahrer, In re, 140 U. S. 545, 11 Sup. Ct. 865, 35 L. Ed. 572.....	242	Royer v. Coupe (C. C.) 29 Fed. 358, 39 O. G. 239	926
Raimond v. Terrebonne Parish, 132 U. S. 192, 194, 10 Sup. Ct. 57, 33 L. Ed. 309 ..	566	Rozo v. The Neversink, Fed. Cas. No. 12-079	763
Rainey v. Herbert, 5 C. C. A. 183, 55 Fed. 443	318	Ruberg v. Brown, 50 S. C. 398, 27 S. E. 873	709
Ramsay v. Allegre, 12 Wheat. 611, 6 L. Ed. 746	743, 744	Russell v. Place, 94 U. S. 606, 24 L. Ed. 214	372
Randall v. Chubb, 46 Mich. 311, 9 N. W. 429, 41 Am. Rep. 165.....	142	Russell v. Railroad Co., 32 Minn. 230, 233, 20 N. W. 147	292
Ransom v. Nichols, 22 N. Y. 110	471	Russell v. Winne, 37 N. Y. 591, 97 Am. Dec. 755	109
Rathbone, In re, 2 Ben. 138, 1 N. B. R. 294, Fed. Cas. No. 11,580	511	Rutledge v. Crawford, 91 Cal. 533, 27 Pac. 779, 13 L. R. A. 761, 25 Am. St. Rep. 212	59
Rawson v. Holland, 59 N. Y. 611, 615, 17 Am. Rep. 394	811	Ryder v. Hulse, 24 N. Y. 372.....	471
Ray v. Gas Co., 138 Pa. 576, 20 Atl. 1065, 12 L. R. A. 290, 21 Am. St. Rep. 922 ..	201		
Ray v. Norseworthy, 23 Wall. 128, 135, 23 L. Ed. 116	5	Sabariego v. Maverick, 124 U. S. 261, 296, 8 Sup. Ct. 461, 31 L. Ed. 430.....	829
Reagan v. Aiken, 138 U. S. 109, 113, 11 Sup. Ct. 283, 34 L. Ed. 892.....	294	Safe-Deposit Co. v. Huntington, 117 U. S. 280, 6 Sup. Ct. 733, 29 L. Ed. 898.....	100
Reagan v. Trust Co., 154 U. S. 362, 14 Sup. Ct. 1047, 38 L. Ed. 1014.....	794	Saginaw, The (D. C.) 95 Fed. 703.....	256
Reed v. U. S., 11 Wall. 591, 20 L. Ed. 220 ..	119	St. Clair v. Cox, 106 U. S. 350, 1 Sup. Ct. 354, 27 L. Ed. 222	425
Reeve v. Davis, 1 Adol. & E. 312.....	731	St. Clair Co. v. Lovingsston, 23 Wall. 46, 23 L. Ed. 59.....	822, 829
Reichman, In re (D. C.) 91 Fed. 624.....	989	Saintier v. Ferguson, 1 Mach. & G. 286 ..	589
Resolute, The, 168 U. S. 437, 18 Sup. Ct. 112, 42 L. Ed. 533	464	St. Jago de Cuba, The, 9 Wheat. 409, 416, 6 L. Ed. 122.....	743, 762
Reynes v. Dumont, 130 U. S. 354, 9 Sup. Ct. 486, 32 L. Ed. 934.....	956	St. Joseph Terminal R. Co. v. Railroad Co., 94 Mo. 536, 6 S. W. 691.....	216
Rhodes v. Iowa, 170 U. S. 412, 18 Sup. Ct. 664, 42 L. Ed. 1088.....	242	St. Lawrence, The, 1 Black, 522, 527-529, 531, 17 L. Ed. 180.....	745, 747-749
Rice v. Nolan, 33 Kan. 28, 33, 5 Pac. 437 ..	340	St. Louis, I. M. & S. R. Co. v. B'Shears, 59 Ark. 237, 244, 27 S. W. 2.....	15, 16
Rice v. U. S., 4 C. C. A. 104, 53 Fed. 910 ..	336	St. Louis, I. M. & S. R. Co. v. Hagan, 42 Ark. 122	16
Rich v. Coe, 2 Cowp. 636, 639.....	731, 732, 738	St. Louis & S. F. R. Co. v. McBride, 141 U. S. 127, 11 Sup. Ct. 982, 35 L. Ed. 659	396
Richardson v. Sanborn, 33 Vt. 75.....	556	St. Nicholas, The (D. C.) 49 Fed. 671.....	464
Richmond, The (D. C.) 114 Fed. 208.....	461	St. Paul, M. & M. R. Co. v. Burton, 111 U. S. 788, 4 Sup. Ct. 699, 28 L. Ed. 604 ..	789
Richmond v. Irons, 121 U. S. 27, 43, 47, 7 Sup. Ct. 788, 30 L. Ed. 864.....	444, 511	St. Paul, M. & M. R. Co. v. Sage, 17 C. C. A. 553, 565, 71 Fed. 40, 47.....	16
Riddle v. Gage, 37 N. H. 519, 75 Am. Dec. 151	556	Salem Iron Co. v. Iron Mines, 50 C. C. A. 213, 216, 112 Fed. 239, 241.....	593, 968, 969
Roach v. Mining Co. (C. C.) 7 Fed. 698.....	402	Salisbury v. Seventy Thousand Feet of Lumber (D. C.) 68 Fed. 916.....	1005
Roanoke, The (D. C.) 101 Fed. 298; 46 C. C. A. 618, 107 Fed. 743.....	753, 756	Salkey, In re, 21 Fed. Cas. 235, 238-240 (Nos. 12,253, 12,254)	1014
Robert Fulton, The, Fed. Cas. No. 11,890, 1 Paine, 630	464	Sanders' Adm'x v. Railroad Co., 49 C. C. A. 56, 111 Fed. 708.....	272
Roberts v. City of Boston, 5 Cush. 198.....	382	Sandwich, The, 1 Pet. Adm. 233.....	715
Roberts v. Lewis, 144 U. S. 653, 12 Sup. Ct. 781, 36 L. Ed. 579.....	351	Sanger v. Upton, 91 U. S. 56, 60, 61, 23 L. Ed. 220	444, 649
Roberts v. Railroad Co., 158 U. S. 1, 15 Sup. Ct. 756, 39 L. Ed. 873.....	1017, 1018	Sarah Starr, The, 1 Spr. 453, 455, Fed. Cas. No. 12,354	760
Roberts v. Ryer, 91 U. S. 150, 23 L. Ed. 267	893	Sargent v. Ass'n (C. C.) 35 Fed. 712.....	964
Robins v. McClure, 100 N. Y. 328, 3 N. E. 663, 53 Am. Rep. 184	471	Sarpy v. Papin, 7 Mo. 503.....	177
Robinson v. Lyall, 7 Price 592.....	731		
Rodd v. Heartt, 21 Wall. 601, 22 L. Ed. 654	734		
Roehm v. Horst, 178 U. S. 1, 20 Sup. Ct. 780, 44 L. Ed. 953.....	971, 972		
Rogers v. Vosburgh, 4 Johns. Ch. 84.....	589		
Rome Planing Mill, In re (D. C.) 96 Fed. 812	989		

	Page		Page
Saulet v. Shepherd, 4 Wall. 502, 18 L. Ed. 442	822	Shinney v. Building Co. (C. C.) 97 Fed.	397
Savannah F. & W. R. Co. v. Holland, 82 Ga. 257, 271, 10 S. E. 200, 14 Am. St. Rep. 158	403, 404	Ship Enterprise, The, Hopk. Judgm. 171	732
Savannah Real-Estate, Loan & Building Co. v. Silverberg, 108 Ga. 281, 33 S. E. 903	657	Shively v. Bowlby, 152 U. S. 1, 14 Sup. Ct. 548, 38 L. Ed. 331	88, 836
Savery v. Dyer, 1 Amb. 139	694	Shreve v. Cheeseman, 16 C. C. A. 413, 414, 69 Fed. 785, 786	15
Savings Bank v. Ward, 100 U. S. 195, 25 L. Ed. 621	575	Shrewsbury v. The Two Friends, Bee. 433, Fed. Cas. No. 12,819; Fed. Cas. No. 17-938	737, 738
Sawyer v. Kochersperger, 170 U. S. 303, 18 Sup. Ct. 946, 42 L. Ed. 1046	976	Sidway v. Live Stock Co. (C. C.) 116 Fed. 389	216
Saxlehner v. Eisner & Mendelson Co., 179 U. S. 33, 21 Sup. Ct. 7, 45 L. Ed. 60	223	Signey L. Wright, The, 5 Hughes, 474, Fed. Cas. No. 6,082a	753
Scaife v. Land Co., 33 C. C. A. 47, 90 Fed. 238, 246	294	Sillivant v. Reardon, 5 Ark. 140	147
Schering v. U. S., 119 Fed. 472	473	Simondson v. Manelli (1597) Sel. Pl. II, 185	724
Schlesinger, In re (D. C.) 3 Am. Bankr. R. 342, 97 Fed. 930, 932; 4 Am. Bankr. R. 361, 42 C. C. A. 207, 208, 102 Fed. 117	1014	Simonson, In re (D. C.) 92 Fed. 904, 1 Am. Bankr. R. 197	517
Schlitz Brewing Co. v. U. S., 181 U. S. 584, 21 Sup. Ct. 740, 45 L. Ed. 1013	496	Sims v. Cumby, 53 Ark. 421, 14 S. W. 623	16
Schneider v. Marinelli, 62 N. J. Law, 740, 42 Atl. 1077	129	Skinner v. The Dove (1675) Vice Adm. Ct. Mass. 372	724
Schollenberger, Ex parte, 96 U. S. 369, 24 L. Ed. 853	394, 396	Slawson v. Railroad Co., 107 U. S. 649, 2 Sup. Ct. 663, 27 L. Ed. 576	595
Schrieber & Sons Co. v. Grimm, 19 C. C. A. 67, 72 Fed. 671	893	Sloane v. Railroad Co., 111 Cal. 668, 685, 44 Pac. 320, 32 L. R. A. 193	404
Scollay v. Dunn, Quincy, 74	736	S. L. Watson, The (D. C.) 113 Fed. 779	722
Scott v. Donald, 165 U. S. 107, 114, 17 Sup. Ct. 262, 41 L. Ed. 648	318	Smith, In re (D. C.) 16 Fed. 465, 467	511
Scott v. Neely, 140 U. S. 106, 109, 110, 113, 11 Sup. Ct. 712, 713, 35 L. Ed. 358	432, 771, 777	Smith v. Adams, 130 U. S. 167, 9 Sup. Ct. 566, 32 L. Ed. 895	1016
Scott v. Reid, 10 Pet. 524, 9 L. Ed. 519	17	Smith v. Bourbon Co., 127 U. S. 110, 8 Sup. Ct. 1043, 32 L. Ed. 73	771, 778
Scott v. Shepherd, 2 W. Bl. 892	946	Smith v. McCall's Heirs, 2 Humph. 163	831
Scott's Adm'r v. Stockton, 18 C. C. A. 408, 72 Fed. 1	354	Smith v. Nichols, 21 Wall. 112, 119, 22 L. Ed. 566	162, 596
Scovill v. Thayer, 105 U. S. 143, 26 L. Ed. 968	649	Smith v. Railroad Co., 72 Hun. 545, 25 N. Y. Supp. 638	292
Scranton v. Wheeler, 6 C. C. A. 585, 57 Fed. 803	836	Smith v. Shoemaker, 17 Wall. 630, 639, 21 L. Ed. 717	76
Searl v. School Dist. No. 2, 124 U. S. 197, 8 Sup. Ct. 460, 31 L. Ed. 415	213	Smith v. State, 66 Md. 215, 7 Atl. 49	13, 14
Sears v. Gunter, 39 Miss. 338	867	Smith v. Tilly (1665) 1 Keb. 708	728
Second Nat. Bank v. Grand Lodge, 98 U. S. 123, 25 L. Ed. 75	695	Smith v. Woolfolk, 115 U. S. 143, 148, 5 Sup. Ct. 1177, 29 L. Ed. 357	511
Second Nat. Bank v. Hunt, 11 Wall. 391, 20 L. Ed. 190	109	Smokey v. Wack, 57 Miss. 833	867
Seward v. Vera Cruz, 10 App. Cas. 59, 70 Sewing Mach. Co.'s Case, 18 Wall. 553, 21 L. Ed. 914	985, 237	S. M. Whipple, The (D. C.) 14 Fed. 354	760, 761
Shainwald v. Davids (D. C.) 69 Fed. 704	237	Smyth v. Ames, 169 U. S. 466, 518, 18 Sup. Ct. 413, 42 L. Ed. 819	794
Shank, Ex parte, 1 Atk. 234	729	Snelling v. Darrell, 17 Ga. 141	513
Shaw v. Bank, 101 U. S. 557, 565, 25 L. Ed. 892	17	Snow v. Nelson (C. C.) 113 Fed. 353, 356	287
Shaw v. Bethune (1725-1730) Prov. Cts. Rec. 182	736	Snowden v. Noah, Hopk. Ch. 347, 14 Am. Dec. 547	223
Shaw v. Coffin, 14 C. B. (N. S.) 372	142	Social Register Ass'n v. Howard (C. C.) 60 Fed. 270	223
Shellington v. Howland, 53 N. Y. 371	445	Societe Fonciere et Agricole des Etats Unis v. Milliken, 135 U. S. 304, 10 Sup. Ct. 823, 34 L. Ed. 208	209
Shepherd v. Pepper, 133 U. S. 626, 10 Sup. Ct. 438, 33 L. Ed. 706	431	Soda Fountain Co. v. Green (C. C.) 69 Fed. 333	924
Shepley v. Cowan, 91 U. S. 330, 340, 23 L. Ed. 424	117	Solomons v. U. S., 137 U. S. 225-343, 11 Sup. Ct. 88, 34 L. Ed. 667	784
Sheppard v. Graves, 14 How. 505, 14 L. Ed. 518	350	Solveig, The, 43 C. C. A. 250, 103 Fed. 322	763
Shields v. Barrow, 17 How. 130, 144, 145, 15 L. Ed. 158	511, 949	Southern Cross Gold & Silver Min. Co. v. Mining Co., 15 Nev. 383	56
Shields v. Hunt, 45 Tex. 435	177	Southern Express Co. v. Brown, 67 Miss. 260, 265, 7 South. 318, 8 South. 425, 19 Am. St. Rep. 306	403
		Southern Pac. Co. v. Burke, 9 C. C. A. 229, 60 Fed. 704	292

	Page		Page
Southern Pac. Co. v. Seley, 152 U. S. 145, 154, 14 Sup. Ct. 530, 38 L. Ed. 391.....	292	Stroma, The (D. C.) 41 Fed. 599; 3 C. C. A. 530, 53 Fed. 281, 283, 284.....	753, 763
Southern Ry. v. Steel Co., 176 U. S. 257, 20 Sup. Ct. 347, 44 L. Ed. 458.....	397	Stuart v. Clark's Lessee, 2 Swan, 10, 58 Am. Dec. 49.....	833
Sovereign Camp of Woodmen of the World v. Jackson, 38 C. C. A. 208, 97 Fed. 382	77	Sturges v. Crowninshield, 4 Wheat. 122, 4 L. Ed. 529.....	16
Speerman v. Degrave, 2 Vern. 643.....	759	Stutsman County, In re (C. C.) 88 Fed. 337-341.....	214
Speidel v. Henrici, 120 U. S. 377, 7 Sup. Ct. 610, 30 L. Ed. 718.....	106	Styles v. Gray, 10 Tex. 503, 508.....	176
Springer v. City of Chicago, 135 Ill. 552, 26 N. E. 514, 12 L. R. A. 609.....	668	Stylov v. Insurance Co., 69 Wis. 224, 34 N. W. 151, 2 Am. St. Rep. 738.....	675
Stackwood v. Dunn, 3 Q. B. 822.....	146	Sullivan v. Nicoulin, 113 Iowa, 76, 84 N. W. 978.....	147
Stainbank v. Finning, 11 C. B. 51.....	744	Sullivan v. Railroad Co., 94 U. S. 806, 24 L. Ed. 324.....	208
Standish v. Radley, 2 Atk. 177.....	638	Sumner v. Sawtelle, 8 Minn. 309 (Gil. 272)	342
Stanley v. The Adventure, Vice Adm. Ct. Mass. 1, 105.....	735	Sun Printing & Publishing Ass'n v. Ed- wards, 51 C. C. A. 279, 113 Fed. 445...	374
Stanton v. Embrey, 93 U. S. 548, 23 L. Ed. 983.....	680	Sun Printing & Publishing Ass'n v. Moore, 183 U. S. 642, 654, 22 Sup. Ct. 240, 46 L. Ed. 366.....	229
Starry v. Korab, 65 Iowa, 267, 269, 21 N. W. 600.....	23	Supervisors v. U. S., 4 Wall. 435, 18 L. Ed. 419.....	46
State v. Carl, 43 Ark. 353, 51 Am. Rep. 565.....	244	Supreme Lodge v. Kalinski, 163 U. S. 289, 16 Sup. Ct. 1047, 41 L. Ed. 163.....	675
State v. Com'rs, 11 Ohio St. 190; 35 Ohio St. 459; 37 Ohio St. 526.....	45-47	Swain v. Schieffelin, 134 N. Y. 471, 473, 31 N. E. 1025, 18 L. R. A. 385.....	151
State v. Express Co., 70 Iowa, 271, 30 N. W. 568; 92 N. W. 66.....	244	Swan v. Newman, 3 Head, 288.....	515
State v. Flanagan, 38 W. Va. 53, 17 S. E. 792, 22 L. R. A. 430, 45 Am. St. Rep. 832.....	244	Swann v. Ass'n (C. C.) 100 Fed. 922.....	425
State v. Hanaphy (Iowa) 90 N. W. 601.....	244	Swanson v. City of Ottumwa, 91 N. W. 1048.....	323, 324
State v. McCann, 21 Ohio St. 198.....	382	Swarts v. Siegel (C. C. A.) 117 Fed. 13.....	16
State v. Pacific Guano Co., 26 S. C. 50.....	835	Swayze v. Burke, 12 Pet. 11, 9 L. Ed. 980	695
State v. Peters, 91 Me. 31, 39 Atl. 342.....	244	Sweetland v. Railroad Co., 117 Mich. 329, 334, 75 N. W. 1066, 43 L. R. A. 568...	403
State v. Refining Co., 51 La. Ann. 562, 25 South. 447.....	691	Swift v. The Albus, Fed. Cas. No. 13,694	761
State v. Simpkins, 77 Iowa, 676, 678, 42 N. W. 516.....	75	Synnott v. Ass'n (C. C. A.) 117 Fed. 379	662
State v. Waite (Iowa) 70 N. W. 596.....	234	Syracuse, The, 12 Wall. 171, 20 L. Ed. 382	230
Stead v. Anderson, 4 C. B. 806.....	704	Taft v. Railroad Co., 8 R. I. 310, 5 Am. Rep. 575.....	662
Stearns v. Lawrence, 28 C. C. A. 66, 83 Fed. 738.....	790	Tanner v. Bennett, Ryan & M. 182.....	31
Steelsmith v. Gartlan, 45 W. Va. 27, 29 S. E. 978, 44 L. R. A. 107.....	200	Tarleton v. McGawley, Peake, N. P. (Ed. 1795) p. 270.....	946
Steinat v. Deuster, 23 Wis. 136.....	109	Tasker v. Gale (1634) 1 Rolle, Abr. 583 726.....	727
Steiner v. Coxe, 4 Barr, 13.....	177	Tatum v. Sawyer, 9 N. C. 226.....	835
Stensgaard v. Smith, 43 Minn. 11, 44 N. W. 669, 19 Am. St. Rep. 205.....	13	Taylor v. Carryl, 20 How. 583, 15 L. Ed. 1028.....	464
Sternes, Ex parte, 77 Cal. 156, 19 Pac. 275, 11 Am. St. Rep. 251.....	129	Taylor v. Com., Fed. Cas. No. 13,788...	756
Stevens v. Ohio (C. C.) 93 Fed. 793.....	245	Taylor v. Dougherty, 1 Watts & S. 326...	177
Stevens v. The Sandwich, 1 Pet. Adm. 233, Fed. Cas. No. 13,409.....	741	Taylor v. Middleton, 67 Cal. 656, 8 Pac. 594.....	56
Stewart v. Emerson, 52 N. H. 301.....	560	Tennessee v. Bank, 152 U. S. 454-462, 14 Sup. Ct. 654, 657, 38 L. Ed. 511.....	214, 976
Stewart v. Harris, 9 Humph. 715.....	831	Terminal Ry. v. Lumber Co., 37 Fed. 3.....	213
Stewart v. Railroad Co., 168 U. S. 445, 449, 18 Sup. Ct. 105, 42 L. Ed. 537.....	401	Terrell, In re (C. C.) 51 Fed. 213.....	93
Stinson v. Dousman, 20 How. 461, 15 L. Ed. 966.....	318	Texas & P. R. Co. v. Archibald, 170 U. S. 665, 666, 18 Sup. Ct. 777, 42 L. Ed. 1188.....	292
Stinson's Lessee v. Russell, 2 Tenn. 40.....	828	Texas & P. R. Co. v. Cox, 145 U. S. 593, 606, 12 Sup. Ct. 905, 38 L. Ed. 829.....	293
Stirlen v. Neustadt, 50 Ill. App. 378.....	518	Texas & P. R. Co. v. Volk, 151 U. S. 73, 77, 14 Sup. Ct. 239, 38 L. Ed. 78.....	293
Stoddard v. Lum, 159 N. Y. 265-273, 53 N. E. 1108, 45 L. R. A. 551, 70 Am. St. Rep. 541.....	444, 445	Texas & P. R. Co. v. Wineland, 42 C. C. A. 588, 102 Fed. 673, 676.....	294
Stokes v. U. S., 157 U. S. 187, 15 Sup. Ct. 617, 39 L. Ed. 667.....	94	Thayer v. Wales, 5 Fish. Pat. Cas. 448, Fed. Cas. No. 13,872.....	944
Store Service Co. v. Whipple (C. C.) 75 Fed. 27.....	615	Third Nat. Bank v. Teal (C. C.) 5 Fed. 503	866
Store Service Co. v. Wilson (C. C.) 83 Fed. 201.....	615	Thomas v. Osborn, 19 How. 22, 31, 15 L. Ed. 534.....	754
Strepy v. Stark (Colo.) 5 Pac. 111, 114..	170		

	Page		Page
Thomas v. Smith, 42 Pa. 68, 73.....	577	Union Cent. Life Ins. Co. v. Champlin	
Thomas Fletcher, The (C. C.) 24 Fed. 375	751	(C. C. A.) 116 Fed. 858.....	13
Thomas P. Sheldon, The (D. C.) 113 Fed.		Union Express, The, 1 Brown, Adm. 537,	
779.....	722	Fed. Cas. Nos. 14,363, 14,364.....	756, 757
Thomlinson's Case, 12 Coke, 104; (1605)		Union Mut. Life Ins. Co. v. Hanford, 143	
12 Rep. 104.....	727, 728	U. S. 187, 12 Sup. Ct. 437, 36 L. Ed. 118	
Thompson v. Boisselier, 114 U. S. 1, 5			695, 771
Sup. Ct. 1042, 29 L. Ed. 76.....	596	Union Mut. Life Ins. Co. v. Payne, 45 C.	
Thompson v. Railroad Co., 110 Mo. 147, 19		C. A. 193, 105 Fed. 172, 176.....	294
S. W. 77; 6 Wall. 134, 18 L. Ed. 765		Union Pac. R. Co. v. Barnes, 12 C. C.	
	216, 695	A. 48, 50, 64 Fed. 80, 82.....	23
Thompson v. Spray, 72 Cal. 528, 533, 14		U. S. v. Babbitt, 1 Black, 55, 61, 17 L.	
Pac. 132.....	170	Ed. 94.....	9
Thomson v. Wooster, 114 U. S. 104, 5		U. S. v. Battle, 4 C. C. A. 249, 54 Fed. 141	473
Sup. Ct. 788, 29 L. Ed. 105.....	383	U. S. v. Bell, 111 U. S. 477, 4 Sup. Ct. 498,	
Thornton v. The Elizabeth Bonaventure,		28 L. Ed. 477.....	789
Sel. Pl. I, 131.....	721	U. S. v. Bevans, 3 Wheat, 336, 383, 388, 4	
Thouren v. Railroad Co. (C. C.) 38 Fed.		L. Ed. 404.....	736, 741
673.....	985	U. S. v. Brawner (D. C.) 7 Fed. 86.....	93
Thurber v. Miller, 14 C. C. A. 432, 67 Fed.		U. S. v. Buckley (D. C.) 31 Fed. 804.....	625
371.....	10	U. S. v. Buntin (C. C.) 10 Fed. 736.....	382
Tiernan v. Woodruff, 5 McLean, 135, Fed.		U. S. v. Burne, 12 Wall. 247, 20 L. Ed.	
Cas. No. 14,027.....	511	388.....	784
Tilgham v. Baird, 2 Sneed, 196.....	831	U. S. v. Chevalier, 46 C. C. A. 402, 107	
Tilgham v. Proctor, 125 U. S. 136, 149,		Fed. 434.....	245
8 Sup. Ct. 894, 31 L. Ed. 664.....	21	U. S. v. Clark Co., 96 U. S. 211, 24 L.	
Tilton v. Cofield, 93 U. S. 163, 166, 23		Ed. 628.....	46
L. Ed. 858.....	511	U. S. v. De Rivera (C. C.) 73 Fed. 679.....	153
Todd v. Fisher, 26 Tex. 239.....	176	U. S. v. 1150½ Pounds of Celluloid, 27	
Todd v. U. S., 158 U. S. 278, 15 Sup.		C. C. A. 231, 240, 82 Fed. 627, 560, 561, 562	
Ct. 889, 39 L. Ed. 932.....	418	U. S. v. Fisher, 2 Cranch, 358-386, 399, 2	
Tollett, In re, 46 C. C. A. 11, 106 Fed.		L. Ed. 304.....	16, 17, 864
866, 54 L. R. A. 222.....	340	U. S. v. Ft. Scott, 99 U. S. 152, 25 L. Ed.	
Tome v. King, 64 Md. 166, 21 Atl. 279.....	270	348.....	46
Topliff v. Topliff, 145 U. S. 156-170, 12		U. S. v. Freeman, 3 How. 556, 565, 11 L.	
Sup. Ct. 825, 36 L. Ed. 558.....	159	Ed. 724.....	9
Torrence v. Shedd, 144 U. S. 527, 12 Sup.		U. S. v. Godwin (C. C.) 91 Fed. 753.....	587
Ct. 726, 36 L. Ed. 528.....	101	U. S. v. Hartwell, 6 Wall. 396, 18 L. Ed.	
Towle v. Society (C. C.) 60 Fed. 131.....	397	830.....	16
Townsend, In re, 5 C. C. A. 488, 56 Fed.		U. S. v. Henderlong (C. C.) 102 Fed. 2.....	239
222.....	484	U. S. v. Huff, 13 Fed. 630.....	626
Tracy v. Railroad Co., 38 N. Y. 437, 98		U. S. v. Isham, 17 Wall. 496, 21 L. Ed.	
Am. Dec. 54.....	59	728.....	336
Trafford v. Express Co., 8 Lea, 96, 102,		U. S. v. Keane (C. C.) 84 Fed. 330.....	496
109.....	273, 274	U. S. v. Langston, 29 C. C. A. 379, 85	
Trappnall, Ex parte, 6 Ark. 9, 12, 42 Am.		Fed. 613.....	864
Dec. 676.....	14	U. S. v. Lee, 106 U. S. 196, 27 L. Ed. 171	
Tremoulin v. Sands (1697) Comb. 462.....	719		783, 793
Trist v. Child, 21 Wall. 441, 452, 22 L.		U. S. v. Legg, 45 C. C. A. 134, 105 Fed.	
Ed. 623.....	286	930.....	384
Tubbs v. U. S., 44 C. C. A. 357, 105 Fed.		U. S. v. Merck, 13 C. C. A. 432, 66 Fed.	
59.....	76	251.....	587
Tube Works Co. v. Ballou, 146 U. S. 317,		U. S. v. Mining Co. (C. C. A.) 117 Fed.	
13 Sup. Ct. 165, 36 L. Ed. 1070.....	445	481.....	73
Tucker v. Capps (1625) 2 Rolle, 492, 497		U. S. v. Mitchell, 2 Wash. C. C. 478, Fed.	
728.....	728	Cas. No. 15,791.....	789
Tulare Irrigation Dist. v. Shepherd, 185		U. S. v. Mock, 149 U. S. 273, 13 Sup. Ct.	
U. S. 1, 22 Sup. Ct. 531, 46 L. Ed. 773		848, 37 L. Ed. 732.....	567
538.....	721	U. S. v. Palmer, 128 U. S. 262, 271, 9 Sup.	
Turbill's Case, 1 Saund. 67.....		Ct. 104, 32 L. Ed. 442.....	784
Turlock Irrigation Dist. v. Williams, 76		U. S. v. Railroad Co., 164 U. S. 526, 541,	
Cal. 360, 18 Pac. 379.....	538	17 Sup. Ct. 165, 41 L. Ed. 541; 184 U.	
Turnbull v. Payson, 95 U. S. 418, 24 L.		S. 49, 56, 57, 22 Sup. Ct. 285, 46 L.	
Ed. 437.....	788	Ed. 425.....	10, 864
Tynan v. Walker, 35 Cal. 634, 95 Am.		U. S. v. Richards (C. C.) 99 Fed. 262.....	587
Dec. 152.....	13, 14	U. S. v. Sayward, 160 U. S. 493, 16 Sup.	
Underhill v. City of Manchester, 45 N. H.		Ct. 371, 40 L. Ed. 508.....	238
214.....	498	U. S. v. Schering & Glatz, 119 Fed. 473.....	1023
Union Bank v. Bank, 136 U. S. 223, 10		U. S. v. Shea, 152 U. S. 178, 14 Sup. Ct.	
Sup. Ct. 1013, 34 L. Ed. 341.....	396	519, 38 L. Ed. 403.....	119, 229
Union Bank v. Geary, 5 Pet. 114, 8 L. Ed.		U. S. v. Shriver (D. C.) 23 Fed. 134.....	245
60.....	969		

	Page		Page
U. S. v. Stowell, 133 U. S. 1, 10 Sup. Ct. 244, 33 L. Ed. 555.....	561	Washburn & Moen Mfg. Co. v. Insurance Co., 179 U. S. 1, 18, 21 Sup. Ct. 1, 45 L. Ed. 49.....	35
U. S. v. Telephone Co. (C. C.) 29 Fed. 37, 41.....	425	Washer v. Bullit Co., 110 U. S. 558, 562, 4 Sup. Ct. 249, 28 L. Ed. 249.....	75
U. S. v. 208 Bags of Kainit (D. C.) 37 Fed. 326.....	562	Washington Irving, The, Fed. Cas. No. 17,244.....	753
U. S. v. Van Winkle, 51 C. C. A. 533, 113 Fed. 903.....	568	Washington Market Co. v. Hoffman, 101 U. S. 112, 25 L. Ed. 782.....	318
U. S. v. Wigglesworth, 2 Story, 369, Fed. Cas. No. 16,690.....	336	Washington & G. R. Co. v. McDade, 135 U. S. 554, 571, 10 Sup. Ct. 1044, 34 L. Ed. 235.....	293
U. S. v. Wilson, 118 U. S. 86, 89, 6 Sup. Ct. 991, 30 L. Ed. 110.....	346	Water Meter Co. v. Desper, 101 U. S. 332, 25 L. Ed. 1024.....	164
U. S. v. Wiltberger, 5 Wheat. 76, 94, 106, 5 L. Ed. 37.....	13, 14, 213	Watkinson v. Bernardiston (1726) 2 P. Wms. 367.....	727
Upsher v. Rich, 135 U. S. 464.....	213	Watson v. Arbuckle (1711) Mor. Dec. 6262.....	732
Upton v. Larkin, 7 Mout. 449, 17 Pac. 728.....	56	Watson v. Gregg, 10 Watts, 289, 36 Am. Dec. 176.....	825
Vaccaro v. Bank, 4 Am. Bankr. R. 474, 43 C. C. A. 279, 103 Fed. 436.....	992	Watson v. Warner (1659) 2 Sid. 161.....	723, 725, 728
Vail's Ex'rs v. Runyon, 41 N. J. Law, 98.....	63	Wayne Co. v. Kennicott, 103 U. S. 554, 26 L. Ed. 486.....	566
Valencia, The, 165 U. S. 264, 270, 271, 17 Sup. Ct. 323, 325, 41 L. Ed. 710.....	755, 763	Webber v. Railroad Co., 38 C. C. A. 79, 83, 97 Fed. 140, 144.....	16
Vance v. Vance, 108 U. S. 514, 521, 27 L. Ed. 808.....	16	Webster v. Seekamp, 4 Barn. & Ald. 352.....	731
Vandegrift Case, The (C. C.) 107 Fed. 265.....	470	Weir v. Bell, 3 Exch. Div. 243.....	437
Van Gunden v. Iron Co., 3 C. C. A. 294, 296, 52 Fed. 838, 841.....	77	Welch, In re (D. C.) 100 Fed. 65.....	349
Vicksburg Waterworks Co. v. City of Vicksburg, 22 Sup. Ct. 585, 46 L. Ed. 808.....	961	Wentworth v. Goodwin, 21 Me. 150.....	556
Vicksburg & M. R. Co. v. O'Brien, 119 U. S. 99, 103, 7 Sup. Ct. 118, 30 L. Ed. 299.....	76	West v. Smith, 101 U. S. 263, 12 L. Ed. 1130.....	708
Village of Coffeen v. Huber, 78 Ill. App. 455.....	244	Westerdell v. Dale, 7 Term. R. 306.....	732
Village of Kent v. U. S., 51 C. C. A. 189, 113 Fed. 232.....	46	Western Assur. Co. v. Polk, 44 C. C. A. 104, 104 Fed. 649.....	76
Virginia Com'rs, Ex parte, 112 U. S. 177, 5 Sup. Ct. 421, 28 L. Ed. 691.....	354	Western Union Tel. Co. v. Burgess, 47 C. C. A. 168, 108 Fed. 26.....	333
Vogel v. Pekoc, 157 Ill. 339, 42 N. E. 386, 30 L. R. A. 491.....	13	Western & A. R. Co. v. Roberson, 9 C. C. A. 646, 658, 676, 61 Fed. 592.....	272
Voorhees v. Jackson, 10 Pet. 469, 9 L. Ed. 490.....	127	Westervelt v. Gregg, 12 N. Y. 202-206, 62 Am. Dec. 160.....	472
Wabash Western R. Co. v. Brow, 164 U. S. 271, 279, 17 Sup. Ct. 126, 41 L. Ed. 431.....	423, 425	Westinghouse v. Air-Brake Co. (C. C.) 59 Fed. 581; 11 C. C. A. 528, 63 Fed. 962; (C. C.) 65 Fed. 99; (C. C.) 77 Fed. 616; (C. C.) 112 Fed. 424, 170 U. S. 537, 569, 18 Sup. Ct. 707, 42 L. Ed. 1136.....	174, 874, 879
Wagner v. Stocking, 22 Ohio St. 297.....	147	Westinghouse Elec. & Mfg. Co. v. Electric Light Co., 51 C. C. A. 514, 113 Fed. 884, 887.....	185, 366
Waite, In re (D. C.) 81 Fed. 359; 31 C. C. A. 403, 83 Fed. 102.....	234	Weston v. Charleston, 2 Pet. 464, 7 L. Ed. 486.....	216
Wakefield v. Cloud, Vice Adm. Ct. Mass. II. 96.....	735	West Plains Tp. v. Sage, 16 C. C. A. 553, 566, 60 Fed. 943, 946.....	15
Walker v. Collins, 167 U. S. 57, 17 Sup. Ct. 739, 42 L. Ed. 76.....	976	West Pub. Co. v. Publishing Co., 25 C. C. A. 648, 79 Fed. 756, 35 L. R. A. 400.....	221
Walker v. Fox, 85 Tenn. 154, 2 S. W. 98.....	828	West Virginia Transp. Co. v. Oil Co. (W. Va.) 40 S. E. 591, 56 L. R. A. 804.....	947
Walkyrien, The, 11 Blatchf. 241, Fed. Cas. No. 17,092.....	751, 756	Wetherbee v. Baker, 35 N. J. Eq. 507.....	443
Ward v. Flood, 48 Cal. 36, 17 Am. Rep. 405.....	382	Wetzel v. Transfer Co., 12 C. C. A. 490, 493, 494, 65 Fed. 23.....	106
Wardell v. Railroad Co., 103 U. S. 651, 26 L. Ed. 509.....	646	Whalen v. Gordon, 37 C. C. A. 70, 95 Fed. 305.....	973
Waring v. Clarke, 5 How. 441, 452, 454, 457, 461, 464, 477, 12 L. Ed. 226.....	733, 734, 736, 741, 744	Whaley v. Catlett, 103 Tenn. 347, 351, 53 S. W. 131.....	275
Warner v. Wheeler, Sel. Pl. I. 117.....	721	Whaley v. Lawton, 57 S. C. 256, 35 S. E. 558.....	709
Warren v. Chambers, 25 Ark. 120, 91 Am. Dec. 538, 4 Am. Rep. 23.....	834	W. H. Beard Dredging Co. v. Hughes (D. C.) 113 Fed. 680.....	229
Warren v. King, 108 U. S. 389, 2 Sup. Ct. 789, 27 L. Ed. 769.....	658, 662	Wheelhouse v. Parr, 141 Mass. 593, 6 N. E. 787.....	244
Warren v. Paving Co., 115 Mo. 572, 576, 22 S. W. 490.....	16		

	Page		Page
Whelan v. Railroad Co. (C. C.) 35 Fed. 849, 1 L. R. A. 65.....	985	Wilton v. Tazwell, 86 Ill. 29.....	450
Whipple v. Mfg. Co., 3 Story, 84, 86, Fed. Cas. No. 17,515.....	806	Winans v. Navigation Co., 6 Blatchf. 215, Fed. Cas. No. 17,862.....	396
Whitaker v. Whitaker, 6 Johns. 112.....	472	Winder v. Caldwell, 14 How. 434, 14 L. Ed. 487.....	146
White v. Ashton, 51 N. Y. 285.....	23	Windsor v. City of Des Moines, 110 Iowa, 175, 81 N. W. 476, 80 Am. St. Rep. 280.....	322
White v. Dunbar, 119 U. S. 47, 7 Sup. Ct. 72, 30 L. Ed. 303.....	884	Winpenny v. City of Philadelphia, 65 Pa. 135; 7 Phila. 111.....	583
White v. McLaren, 151 Mass. 553, 557, 24 N. E. 911.....	151	Winter v. Jones, 10 Ga. 206, 54 Am. Dec. 379.....	177
Whitehead v. Munday, 91 Ga. 198, 17 S. E. 287.....	340, 341	Winter v. Simonton, 3 Cranch, C. C. 104, Fed. Cas. No. 17,894.....	123
Whitlatch v. Casualty Co., 149 N. Y. 50, 43 N. E. 405.....	408	Winters v. Drake (C. C.) 102 Fed. 550.....	213
Whitworth v. Railroad Co. (C. C.) 107 Fed. 557.....	240	Winthrop v. Sloop Africa, Vice Adm. Ct. Mass. I, 132.....	724, 735
Wickliffe v. Owings, 17 How. 47, 15 L. Ed. 44.....	352	Witte v. Koeppen, 11 S. D. 598, 79 N. W. 831, 74 Am. St. Rep. 826.....	16
Wight v. Du Bois (C. C.) 21 Fed. 693, 696	124	Wolfe v. Jasspon, 126 Mich. 11, 85 N. W. 260.....	147
Wilcox v. Blackwell, 99 Tenn. 352, 41 S. W. 1061.....	826	Wollensak v. Reiher, 115 U. S. 96, 5 Sup. Ct. 1137, 29 L. Ed. 350.....	159
Wilders S. S. Co. v. Low, 50 C. C. A. 473, 112 Fed. 161, 166, 172.....	461	Wollensak v. Sargent, 151 U. S. 228, 229, 14 Sup. Ct. 291, 38 L. Ed. 137.....	160
Wilkes Co. v. Coler, 180 U. S. 506, 21 Sup. Ct. 458, 45 L. Ed. 642.....	47	Wood v. Carpenter, 101 U. S. 135, 139, 25 L. Ed. 807.....	106
Wilkins v. Carmichael, 1 Doug. 101.....	729, 732	Wood v. Casserleigh (Colo.) 71 Pac. 360.....	313
Wilkinson v. Searcy, 76 Ala. 176, 182.....	403, 404	Wood v. Elledge, 11 Heisk. 612.....	832
Willamette Valley, The, 13 C. C. A. 635, 637, 638, 66 Fed. 565, 566, 567.....	463	Wood v. Hamilton, 3 Paton, 148.....	732, 733
Willard v. Tayloe, 8 Wall. 557, 567, 19 L. Ed. 501.....	287	Woodin v. Bagley, 13 Wend. 453.....	472
Willard v. Wood, 135 U. S. 309, 10 Sup. Ct. 831, 34 L. Ed. 210.....	695, 769	Woodruff v. The Levi Dearborn, Fed. Cas. No. 17,987.....	738
William Cook, The (D. C.) 12 Fed. 919, 920.....	751, 763	Woodworth v. Insurance Co., 185 U. S. 354, 22 Sup. Ct. 676, 46 L. Ed. 945.....	149
Williams v. Mitchell, 45 C. C. A. 265, 106 Fed. 168.....	940, 941	Woolsey v. Ryan, 59 Kan. 601, 54 Pac. 664.....	13
Williamson v. Jones, 43 W. Va. 562, 27 S. E. 411, 38 L. R. A. 694, 64 Am. St. Rep. 891.....	196	Wright v. Grant, 6 N. Y. St. Rep. 362.....	410
Wilmer v. Railroad Co., 2 Woods, 410, Fed. Cas. No. 17,775.....	399	Wyckoff v. Runyon, 33 N. J. Law, 107.....	556
Wilson v. Bank, 17 Wall. 486, 21 L. Ed. 723.....	213	Yahoola River & C. C. Hydraulic Hose Min. Co. v. Irby, 40 Ga. 479.....	825
Wilson v. Dawson, 52 Ind. 513, 515.....	956	Yates v. Hall, 1 Term. R. 73.....	731
Wilson v. Nelson, 183 U. S. 191, 22 Sup. Ct. 74, 46 L. Ed. 147.....	989, 990	Yazoo & M. V. R. Co. v. Thomas, 132 U. S. 174, 188, 10 Sup. Ct. 68, 33 L. Ed. 302.....	864
Wilson v. Seligman, 144 U. S. 41, 12 Sup. Ct. 541, 36 L. Ed. 338.....	424	York v. Texas, 137 U. S. 15, 11 Sup. Ct. 9, 34 L. Ed. 604.....	424
Wilson v. Store Service Co., 31 C. C. A. 533, 88 Fed. 286.....	615	Young v. Oil Co., 194 Pa. 243, 45 Atl. 121.....	198
Wilson v. Trust Co., 183 U. S. 121, 22 Sup. Ct. 55, 46 L. Ed. 113.....	554	Young Mechanic, The, 2 Curt. 404, 408, Fed. Cas. No. 18,180.....	715, 716
Wilson v. Youst, 43 W. Va. 826, 28 S. E. 781, 39 L. R. A. 292.....	196	Zodiac, The (D. C.) 5 Fed. 220, 222; 1 Hagg. Adm. 320.....	511, 725
		Zollars v. Evans, 5 Fed. 172, 175, 2 McCrary, 39.....	170

CASES

ARGUED AND DETERMINED

IN THE

UNITED STATES CIRCUIT COURTS OF APPEALS AND THE CIRCUIT AND DISTRICT COURTS.

CHAUNCEY et al. v. DYKE BROS. et al.

(Circuit Court of Appeals, Eighth Circuit. November 28, 1902.)

No. 1,672.

1. BANKRUPTCY—JURISDICTION—CONFLICTING LIENS.

Where the bankrupt court has acquired the lawful custody of property to which conflicting liens attach, it has jurisdiction to determine the priorities of such liens, though the trustee has no interest in such question.

2. SAME—WAIVER OF OBJECTIONS.

A trustee in bankruptcy filed a petition asking for permission to sell, free of incumbrances, certain real estate of the bankrupt which was incumbered both by a mortgage and by mechanics' liens, and that the proceeds of the sale should stand in lieu of the property. Thereupon the mortgagees and lienholders agreed to submit the priority of their liens to the decision of the referee, and that the sale should be postponed until after such priorities had been disposed of. *Held*, that such stipulation operated as a consent on the part of the mortgagees that the property might be sold free of all liens, and gave the bankrupt court lawful custody of the same and the proceeds realized therefrom.

3. MECHANICS' LIENS—MORTGAGES—PRIORITY ON IMPROVEMENTS—USE OF BORROWED MONEY.

Acts Ark. 1895, p. 217, § 3, provides that a mechanic's lien shall attach to the buildings in preference to any prior incumbrances existing upon the land: provided, however, that where the prior incumbrance was executed to raise money with which to make such improvements then the lien should be prior to the lien given by the act. Section 10 provides that contractors for the erection of improvements must, on request, furnish to a mortgagee a full list of the claims of those laboring on an improvement or furnishing material therefor. A mortgage was executed for the purpose of securing money for improvements, but only a portion thereof went to pay for labor or material, the balance being turned over to the mortgagor, who diverted it from such purpose. *Held*, that the liens of laborers and materialmen on the improvements would be superior to that of the mortgagees, as to such portion turned over to the mortgagor.

4. SAME—PRIORITY ON LAND—DISTRIBUTION.

On a distribution of the proceeds of the property, the value of the land, on which the mortgage was an undoubted prior lien, should be applied pro rata to the payment of both portions of the mortgage.

5. SAME—ASSUMPTION OF DEBT.

After the execution of the mortgage, the agent of the mortgagees retained the money, and material was furnished on his representation by one materialman that there was still \$1,500 left, and that he would see that such material was paid for out of that fund. *Held*, that in a distribution of the proceeds of the property, including both the improvements and the land, the claim of this materialman was entitled to preference over that of the mortgagees, since, even if they were not estopped from asserting the priority of their lien, they had "assumed" the payment of the claim for the material.

Sanborn, Circuit Judge, dissenting.

Appeal from the District Court of the United States for the Western District of Arkansas.

Joe P. Matthews was adjudicated a bankrupt by the district court of the United States for the Western district of Arkansas, and in the course of such proceeding A. A. McDonald, one of the appellees, was appointed trustee of his estate. At the time of the adjudication the bankrupt owned lot 7, in block 530, in Reserve addition to the city of Fort Smith, Ark., which property was subject to a deed of trust or mortgage held by Elihu Chauncey, Charles Chauncey, and William L. Savage, as trustees, to secure a note of \$4,000, dated April 28, 1899, and due April 28, 1904, to which note 10 semi-annual interest coupons were attached, each coupon representing six months' interest on the loan. At the time of the adjudication, or shortly thereafter, certain mechanics' liens had been or were filed against the mortgaged property for materials supplied in the erection of a building thereon. One of such liens was filed by Dyke Bros., one of the appellees, another by J. M. Tenney & Co., another of the appellees, and another by H. I. Goddard, the remaining appellee. On May 4, 1900, McDonald, as trustee of the bankrupt's estate, filed a petition setting forth the incumbrances that existed upon the property, and praying for an order that he, as owner of the equity of redemption in the property, might be authorized to sell it free and clear of all liens; the proceeds received at such sale to stand in lieu of the property, and to be distributed according to the various priorities of the lien claimants as they might thereafter be determined. He also prayed that the owner of the debt secured by the deed of trust might be restrained from selling the mortgaged property in pursuance of the power of sale contained in the mortgage. After such a petition had been filed, and the parties affected thereby had been served with notice of the same, and cited to appear and show cause why the order prayed for should not be granted, they appeared before the referee in bankruptcy; whereupon the trustees in the deed of trust, namely, the present appellants, entered into an agreement with the various holders of mechanics' liens, to wit, the present appellees, to the effect that they would file with the referee in bankruptcy their respective interventions, setting up their respective claims to priority of payment, and that no injunction should be issued against the owner of the deed of trust, and that no sale of the property should be made until the rights and priorities of the respective parties had been definitely settled and determined by the referee upon said interventions. Thereupon a hearing at considerable length was had before the referee, who decided that the lien of the mortgage or deed of trust was superior to that of the mechanics' liens which had been filed against the property, and directed that the property be sold free and clear of all liens and incumbrances by the trustee in bankruptcy. The case was then certified into the district court, and, upon a hearing before that tribunal, the action of the referee, directing that the property be sold free and clear of all liens and incumbrances, was approved. The district court decided, however, that the claim of Dyke Bros. was entitled to priority and should be paid in full; that the sum of \$3,000 should next be paid to the owner of the deed of trust; and that the claims of J. M. Tenney & Co. and H. I. Goddard, the appellees, be next paid. The trustees in the deed of trust excepted to this order of the district court, and have brought the case to this court by appeal.

Homer C. Mechem and Edgar E. Bryant, for appellants.
F. A. Youmans and Ira D. Oglesby, for appellees.

Before CALDWELL, SANBORN, and THAYER, Circuit Judges.

THAYER, Circuit Judge, after stating the case as above, delivered the opinion of the court.

The first question which confronts us in this case is one of jurisdiction. The appellants urge, and such is the fact, that they did not present their claim, which was secured by a mortgage or deed of trust, for allowance against the bankrupt's estate; that the trustee in bankruptcy did not dispute the existence of the mortgage indebtedness; that the only real controversy which was tried and determined was that between the mortgagee and the mechanics' lien holders concerning their respective priorities; and that, as this was a controversy in which the bankrupt's estate was in no wise interested, the bankrupt court had no jurisdiction to determine it, and that the power to determine it could not be conferred by consent. It will be conceded that the authority to try the issue which arose between the lien claimants, and to determine their respective priorities, could only be exercised by the bankrupt court in virtue of the fact that by the proceeding in bankruptcy it had acquired the custody of the res to which the controversy related. The bankrupt court had no right to assume jurisdiction of a controversy between third parties, in which the trustee was not concerned, and decide whose claim was paramount in equity, merely because the claimants happened to be creditors of the bankrupt estate, or merely because the liens affected a part of the bankrupt's property. The bankrupt act confers no such authority. But if, in the exercise of its customary jurisdiction, the bankrupt court obtained the lawful custody of the res to which the liens related or of a fund realized from its sale, then the duty which was thereby devolved upon it, of distributing the fund among those to whom it rightfully belonged, did empower it to determine the relative priorities of the conflicting claims to the fund. A court which has lawfully acquired the custody of property or money must of necessity dispose of the same according to law; and, when conflicting claims are preferred, it is not bound to require the claimants to litigate their claims in some other forum, and to adopt the judgment of that tribunal, although it may do so, but it is at liberty to dispose of such controversies according to its own ideas of right and justice. This is one of those incidental powers which may be exercised by any court of record in the absence of an express prohibition. The jurisdictional question, therefore, resolves itself into an inquiry whether the bankrupt court acquired the lawful custody of the fund which was realized by the sale of the mortgaged property. The trustee in bankruptcy clearly had the power, acting under the directions of the bankrupt court, to sell the bankrupt's equity of redemption in the mortgaged property. He would doubtless have discharged his full duty by praying for authority to sell simply the bankrupt's equity of redemption. He saw fit, however, to ask for authority to sell the property free and clear of all liens, and in response

to such an application the mortgagees and the lien claimants appeared, and, without objecting to such order, agreed to submit their respective claims to the arbitrament and decision of the referee, and they further agreed that the sale as prayed for should be postponed until the priorities had been determined. It is obvious that there was no need of submitting and no propriety in submitting this question to the decision of the bankrupt court, unless it was for the purpose of laying the foundation for a proper distribution of the fund realized at the sale of the mortgaged property, after it had been sold free of all liens and incumbrances. Therefore the action that was taken by the appellants in this respect can be regarded in no other light than as a waiver of all objections on their part to a sale of the property free from incumbrances by the trustee in bankruptcy, and as a consent, voluntarily given, that such a sale might be made. It will not be presumed that the appellants and the appellees entered into a stipulation with intent to cast upon the bankrupt court the trial of a moot question, the decision whereof would be extrajudicial and binding upon no one. It must be presumed, on the contrary, that the parties entered into the stipulation aforesaid in good faith, with the understanding that the mortgaged property should be sold free of liens, and that the fund should be divided as the referee or the bankrupt court, after hearing the interventions, might direct. We are constrained to hold, therefore, that the parties in effect agreed that the property in question might be sold free and clear of all liens and incumbrances. This, we think, is the necessary construction which must be placed on the stipulation that was entered into before the referee. Such being the effect of the stipulation, it follows that in a controversy between a purchaser at said sale and these appellants the appellants would be estopped by their own acts from denying that the sale operated to discharge the lien of the mortgage and to transfer it to the fund realized at the sale, and we are of opinion that they cannot in this proceeding challenge the validity of the sale or deny that the proceeds of the sale came into the lawful custody of the trustee in bankruptcy and became subject to the disposition and control of the bankrupt court. The latter court, as we have already remarked, had the power to order the sale of the bankrupt's equity of redemption. The provision that at the sale the property should be sold free of all existing liens was a provision which the appellants consented might be added to the terms of the proposed sale either for their own advantage or convenience; and, even if it should be conceded that under the present bankrupt act the bankrupt court had no power to prescribe this condition without the consent of the lienors, yet, having given such consent and taken part in a long trial to determine their respective priorities, they will not now be heard to complain of an order made, or of action taken, which, if in any respect erroneous, they themselves invited. We accordingly conclude that the lower court had the power, incidental to the right of disposition of a fund that had or would come lawfully into the custody of the trustee in bankruptcy, to determine how the fund should be divided among the rival claimants.

Under the old bankrupt law it was held that a court of bankruptcy

could direct a sale of mortgaged property owned by the bankrupt, divested of all liens, and could determine the priority of liens on the incumbered property, without the consent of the lienors and against their will. *Ray v. Norseworthy*, 23 Wall. 128, 135, 23 L. Ed. 116. It is denied by the appellants that any such power is conferred on courts of bankruptcy by the present bankrupt law because of the omission of those provisions from which, under the old law, the authority in question was derived. But, in view of the fact that the sale in the case in hand was ordered by consent of all parties in interest, it is unnecessary, we think, to express a definite opinion with reference to the last-mentioned contention of the appellants, and none will be expressed at this time.

The only other question to be determined on this appeal is whether the lower court properly construed an act relating to mechanics' liens which was adopted in the state of Arkansas on April 20, 1895. Acts Ark. 1895, p. 217. The question arises in the following manner: When Matthews, the bankrupt, made his application to the appellants for a loan to be secured by mortgage, he represented in his application that the money was borrowed to help build a building on the mortgaged premises, to be used by himself as a wholesale grocery establishment, and that the lot on which the building was to be erected was worth \$2,500, and that the value of the building would be \$5,500. The money, when advanced by the mortgagees in pursuance of this application, was transferred to their agent residing at Ft. Smith, Ark., who had negotiated the loan, the mortgagees being nonresidents. On receipt of the money this agent gave the mortgagor credit therefor on his books, and as the work progressed he paid \$3,000 of the money thus advanced directly to contractors, laborers, and materialmen who were engaged in erecting the building on the mortgaged premises, but he permitted the residue of the fund, to wit, \$1,000, to be expended for other purposes, and that amount never was in fact applied toward the erection of the building. The lien claims that are preferred by the appellees are in the main claims for materials supplied toward the erection of the building, all of which were so supplied subsequent to the execution of the appellants' mortgage and the transfer of the fund to their agent. A part of the claim of one lienholder (H. I. Goddard) appears to be on account of services rendered in drawing plans and specifications for the building in question, the amount of that item being \$174.30. It may be that the lien for this item of his account had attached before the mortgage was executed, but as the lower court treated the whole of Goddard's lien claim as being subsequent in point of time to the mortgage, and as Goddard did not appeal, and as the fund is probably adequate to pay Goddard's claim in full, if the decree of the lower court was in other respects right, we shall proceed on the assumption that all of the mechanics' liens became attached to the property subsequent to the execution of the mortgage, and shall dispose of the case on that assumption.

The lien law of the state of Arkansas that was enacted on April 20, 1895, *supra*, by its first section, gave to every mechanic, builder, artisan, workman, laborer, or other person who should do or per-

form any work upon, or furnish any materials, etc., for, any building, erection, or improvement upon land, or upon any boat or vessel, or for repairing the same, under a contract with the owner thereof or his agent or contractor, upon compliance with the provisions of the act, a lien upon such building, erection, or improvement, and upon the land belonging to such owner, on which the same was situated, to the extent of one acre; or, if the building was upon any lot of land in a town or city, then a lien was given upon the building or improvement, and upon the lot or lots of land upon which the same were situated.

The second section of the act defined the extent of the lien aforesaid, declaring, in substance, that the lien should only bind such right, title, and interest as the person contracting for the erection of the building or improvement possessed.

The third section of the act, over which the controversy in this instance arises, was as follows:

"The lien for the things aforesaid, or work, shall attach to the buildings, erections or other improvements, for which they were furnished or work was done, in preference to any prior lien or incumbrance or mortgage existing upon said land before said buildings, erections, improvements or machinery were erected or put thereon, and any person enforcing such lien may have such building, erection or improvement sold under execution, and the purchaser may remove the same within a reasonable time thereafter: provided, however that in all cases where said prior lien or incumbrance or mortgage was given or executed for the purpose of raising money or funds with which to make such erections, improvements or buildings, then said liens shall be prior to the lien given by this act."

The fourth section of the act related to liens upon leasehold premises.

The fifth section of the act was as follows:

"The lien for work and materials as aforesaid shall be preferred to all other incumbrances which may be attached to or upon such building, bridges, boats or vessels or other improvements, or the ground, or either of them, subsequent to the commencement of such buildings or improvements."

The sixth, seventh, eighth, and ninth sections of the act contained provisions relative to the steps to be taken by lien claimants to secure the benefits of the act. The provisions thereof have no special bearing upon the present controversy.

The tenth section of the act contained a provision, in substance, that any one interested in buildings or grounds on which improvements were being made, "as mortgagee or trustee," might at any time apply to the contractor or subcontractor for a list of all parties doing work or furnishing materials for such improvements, and for a statement of the amount due to each of such persons. It further declared that, if the contractor or subcontractor refused to give correct information on such points when it was applied for, he should be guilty of a misdemeanor, and punished by a fine not exceeding \$500. The remaining provisions of the act have no special bearing upon the existing controversy.

On this state of facts, the question arose in the lower court whether, as respects the \$1,000 of the mortgage indebtedness that had not been applied by the mortgagees' agent towards the erection of the

building on the demised premises, but had been expended for other purposes, the mortgagees were entitled, by virtue of the proviso to section 3 of the mechanics' lien law, *supra*, to priority of payment over the mechanics' lien claimants. The lower court, in an able and carefully prepared opinion (reported in *Re Matthews*, 109 Fed. 603, 610), decided this question in the negative, holding, in substance, that when a person advances money, taking security therefor in the form of a mortgage, which was borrowed by the mortgagor for the professed purpose of erecting a building or improvements on the mortgaged premises, he can claim no priority of lien over persons who have performed labor or furnished materials for the erection of such building or improvements subsequent to the execution of the mortgage, except for such part of the money so advanced by the mortgagee as was actually expended in the erection of such building or improvement. The majority of the members of this court are of opinion that the conclusion reached by the learned judge of the lower court was right, and that it should be affirmed. The lien law in question is a remedial statute. It was enacted to secure to laborers, artisans, and others who perform labor or furnish materials for the erection of buildings on the land of others, payment for such services and materials, by giving them a lien on the structures which they have helped to create, instead of compelling them to rely merely on the personal security of the debtor. That such laws are fair and just, and that they also tend to encourage the erection of buildings by insuring payment for the labor and materials that are expended in their erection, has been generally recognized. *Davis v. Bilsland*, 18 Wall. 659, 661, 21 L. Ed. 969. As such laws are remedial in their nature and are prompted by a wise policy, they should be liberally construed in favor of the class of persons for whose benefit they were intended.

The first section of the act now under consideration declares that those who do work or furnish materials for the erection of an improvement on land shall be entitled to a lien therefor on the land and the improvement. This is a general rule applicable to all cases, and the burden is upon one who disputes the existence of a lien for work done or materials furnished for the purpose aforesaid to make good such contention. Section 3 of the act deals with the subject of priorities, when there are other liens of a different character, the rule prescribed being that, in so far as the improvement is concerned, mechanics' liens shall be preferred over all liens existing on the land even before the improvements were erected, and that they may be sold and removed for the benefit of the laborer and materialman. Then follows the proviso that when a prior lien, by way of mortgage, is given for the purpose of raising money to erect improvements, it shall be entitled to priority. In framing this section of the act the legislature evidently had in mind the comparative equities of one who supplies labor or material for improvements on land and one who furnishes money which is actually expended for the erection of such improvements. These equities were regarded as being equal; hence, the proviso declared, in substance, that the lien which was prior in point of time should be preferred. That

portion of the section, however, which precedes the proviso, clearly recognizes the fact that the equity of one who simply loans money secured by a mortgage on land, which is not used to improve it, is inferior to that of a materialman or laborer who subsequently contributes to the erection of improvements on the land under a contract with the owner, thereby enhancing its value; and the latter lien, as respects the improvement, is preferred. We are constrained to believe that the legislature did not intend to prefer the lien of the mortgagee over that of a laborer or materialman when the former loans his money on the representation that it is borrowed for the purpose of improving the mortgaged property, unless it is in fact expended for that purpose. The contrary view of the statute, that the mere expression by the mortgagor of a purpose to use the money borrowed to improve the mortgaged premises entitles the mortgagee to a preference, would, in effect, nullify that part of section 3 which precedes the proviso, as is very clearly shown in the opinion of the lower court (109 Fed. 311, 312); for, as the proviso does not specify any time, prior to the commencement of an improvement, within which the money must be loaned by the mortgagee, it follows that if it is loaned years before the improvement is commenced, and not a dollar enters into the improvement, nevertheless the mortgagee may successfully assert his priority on the ground that when the loan was made the mortgagor represented that it was to be used for the purpose specified in the proviso. This seems to be a very unreasonable interpretation of the statute, and one that would enable a mortgagee to defeat an equity which the statute clearly recognizes as superior, and an equity which it was designed to protect. Such an interpretation of the statute can hardly be supposed to have been within the contemplation of the lawmaker, when we reflect that the general purpose of the act was to afford greater security to laborers and materialmen, and to restrict, in a measure, the rights of other lienholders. The lien law in question was framed, we think, with reference to the known habits of men who loan money on the security of real estate, with the understanding that it is to be used to enhance its value by improving it. In such cases, as the legislature well knew, the lender usually sees to it that the money is used as the borrower promised to use it. The mortgagees did so in the case in hand; they evidently construed the statute as we construe it; they paid the money, not to the mortgagor to be expended as he thought best, but to laborers and materialmen, except the sum of \$1,000, which amount the mortgagor managed to obtain and used for a different purpose. Therefore, when the proviso gives a preference to mortgagees if they loan money for the purpose of improving mortgaged property, it refers to an executed purpose, and not merely to a purpose expressed by the mortgagor at the time of the loan, which is not carried into effect. If the purpose of the loan is not consummated, the equity of the lender is inferior to that of a mechanic's lien holder.

This view of the statute is confirmed by the tenth section of the act, the substance of which is stated above. By that section the mortgagee is given power to call upon contractors for the erection of an

improvement, at any time, for the names of all materialmen and laborers and the amount due to each, and the contractor is required, under a heavy penalty, to give correct information; the evident purpose of this provision being to enable the mortgagee to expend the money which he loans, exclusively for the payment of such bills. But the act contains no corresponding provision enabling a materialman or a laborer to call upon a mortgagee for information concerning the purpose for which the money secured by his mortgage was loaned and compelling the latter to give such information. He can keep his own counsel, stand by and see materialmen and laborers expend their substance in making the mortgaged property more valuable, and then come forward and assert that by virtue of an oral representation made by the borrower, which was known only to himself, he is entitled to priority. We are of opinion that the legislature did not intend to place laborers and materialmen in that situation.

We are aware that some courts have at times expressed, in strong terms, the necessity of reading and enforcing statutes literally without regard to consequences. Some of these utterances have been called to our attention. But this doctrine of literalism which clings to the letter of a statute and ignores its purpose is not well calculated to promote the ends of justice, and has not been viewed with favor, at least by the federal courts. It is not the duty of a court of justice to perpetuate mistakes inadvertently made by the lawmaker by a blind adherence to the letter of a law, when the purpose of the law is apparent. A legislative enactment should always be so construed as to give effect to the intention of the lawmaker, when it is discernible, even if the language employed to express the intent is in some respects inapt and faulty. This is the primary canon of construction, which dominates all others, inasmuch as construction consists solely in finding out the intent of the lawmaker, with the aid of all such light on the subject as can be obtained. Legislative bodies are not always fortunate in the use of language, but, if careful attention is paid to all the provisions of a statute as well as to the conditions which led to its enactment, little difficulty will generally be experienced in ascertaining what was intended. When the purpose is discovered it should be given effect, since whatever is within the intention of the lawmaker is as much within the statute as if it was within the letter. *U. S. v. Freeman*, 3 How. 556, 565, 11 L. Ed. 724; *U. S. v. Babbitt*, 1 Black, 55, 61; 17 L. Ed. 94. It sometimes happens that the language employed in one paragraph of a statute acquires a new meaning that no one can dispute when read in connection with other provisions of the act, or in connection with prior legislation on the same or a cognate subject, or in the light of the end to be accomplished or the circumstances that gave birth to the enactment. In interpreting and enforcing a statute, therefore, no court should overlook these means of information merely out of deference to particular words of the act which, through haste or inadvertence, may not fully or accurately express its true purpose. Nor are the courts in the habit of giving effect to laws strictly according to the letter, ignoring all other considerations. They will sometimes supply exceptions to a general rule, where none is expressed, as in *Hanger v. Abbott*,

6 Wall. 532, 18 L. Ed. 939, where an exception was implied, although none was expressed, thereby taking a case out of the operation of the statute of limitations. In like manner they will supply words where they seem to have been unintentionally omitted, as in *Kennedy v. Gibson*, 8 Wall. 498, 506, 19 L. Ed. 476, where the word "by" was supplied so as to permit actions in the federal courts to be brought "by" national banks as well as "against" them. Previous legislative enactments and definitions of terms therein contained that have been repealed may also be consulted for the purpose of ascertaining what is meant by like terms as used in subsequent enactments. *Ex parte Crow Dog*, 109 U. S. 556, 3 Sup. Ct. 396, 27 L. Ed. 1030. And where, by certain clauses of a statute relating to the removal of cases to the federal court, the right had been confined to nonresident defendants, thereby establishing a legislative policy on the subject, it was held by this court that the same restriction would be implied in another clause of the act, although it was not in terms expressed. *Thurber v. Miller*, 14 C. C. A. 432, 67 Fed. 371. The decisions in *Fisk v. Henarie*, 142 U. S. 459, 12 Sup. Ct. 207, 35 L. Ed. 1080, and *McDonnell v. Jordan*, 178 U. S. 229, 20 Sup. Ct. 886, 44 L. Ed. 1048, also illustrate in a striking manner to what extent the express words of a statute will be ignored when it is deemed necessary to do so to give effect to the legislative purpose. In those cases the court was dealing with the second section of the judiciary act of 1887 (25 Stat. 433, 435, c. 866), which permits the removal of causes from the state to the federal court on the ground of prejudice or local influence "at any time before the trial thereof." Notwithstanding the use of the latter words, the supreme court decided, basing its ruling on previous legislation and also on the general purpose of the act to restrict jurisdiction of the federal courts, that cases could not be removed on the ground of prejudice and local influence unless the removal was applied for, not as the words of the act declared, "at any time before the trial," but only in the event that the application for a removal was made before or at the term at which the cause could be first tried. In the case of *United States v. Southern Pac. R. Co.*, 184 U. S. 49, 56, 57, 22 Sup. Ct. 285, 46 L. Ed. 425, the supreme court further enforced the doctrine, quoting with approval a paragraph from *Potter*, Dwar. 231, that a court should always so construe a remedial statute as to give effect to the intent of the lawmaker, even if in doing so it is necessary to go beyond the letter of the statute. Indeed, it may be stated generally that no inaccuracy in the use of language, or grammatical errors, or the omission of words or phrases, or the use of the wrong word, will serve to defeat the intent of the lawmaker when the intent can be definitely ascertained. *Bish. Cont.* § 383.

Without pursuing the subject at greater length, it will suffice to say that, after a careful study of the lien law in question, we are of opinion that it was not the intention of the legislature to give mortgagees a preference over the holders of mechanics' liens whose liens are subsequent in point of time, unless the money which they advance is actually expended in the erection of the improvement to which the controversy relates. A mortgagee who does not see to it that the

money advanced is thus expended is in no better situation than one who loans money without any representation on the part of the borrower respecting the use that will be made of it.

With respect to the claim of Dyke Bros., the lower court found that they had furnished materials for the erection of the building in question on the representation of the mortgagees' agent that he had \$1,500 of the mortgagees' money still in his hands unexpended, and that he would see that they were paid for the materials which they supplied out of that fund. For this reason its order of distribution, as heretofore stated, directed that Dyke Bros. should be paid, in preference to the mortgagees, out of the proceeds realized from the sale of the mortgaged property. This finding by the lower court is amply sustained by the testimony, and we would not be warranted in finding to the contrary upon the evidence contained in the present record. Moreover, as the order which was made by the lower court for the distribution of the fund will avoid circuitry of action and discharge an obligation to pay the claim of Dyke Bros., which the mortgagees by their agent (to whom the mortgage, as it seems, has now been assigned) assumed, we think that the order, in so far as it concerns the claim of Dyke Bros., should not be disturbed, even if it be true that the facts as found by the trial court are not sufficient to estop the appellants from asserting the priority of their mortgage lien. The facts as found by the lower court do show that the mortgagees are bound to see that the claim of Dyke Bros. is paid in full, and the order accomplishes that object without the necessity of further litigation.

In framing the order for the distribution of the fund, the lower court seems to have overlooked the fact that the third section of the mechanics' lien law, to which the present discussion relates, gives to laborers and materialmen a preference over a prior incumbrance only as respects the improvements that are erected and not as respects the land. It may be that the sale will produce enough to discharge all the liens, and it may be that the circumstance last mentioned, though fully understood by the trial court, was not regarded as of any special importance for that reason. If enough will not be realized from the sale to discharge the mortgage in full according to the priorities as they have been declared, then the order of distribution as made should be modified so as to secure to the mortgagees, except as to Dyke Bros., their priority as respects the land. Possibly it may be necessary, before the sale, to ascertain the comparative value of the land and improvements as a means of determining the sum realized from each. If such a course is found to be necessary, the sum realized from the land should be applied pro rata so as to reduce that part of the mortgage debt amounting to \$3,000, which is entitled to priority, as respects the improvements, as well as that part of the mortgage debt, to wit, \$1,000, which is not entitled to such priority. If the fund is adequate to pay all the liens, no comparative valuation of the land and improvements would seem to be necessary, as no one will be injured by the enforcement of the existing order.

Finding no other error in the order, it will be affirmed except in the respect last mentioned, and the record will be remitted to the

lower court, with directions to modify its decree as herein explained, if it shall be found necessary to do so for the preservation of the full rights of the appellants.

SANBORN, Circuit Judge (dissenting). I am unable to concur in the view of the majority that it is the duty of this court to substitute in the act of the legislature of Arkansas of 1895 the use of a mortgage loan in the place of the purpose of it as the test of the superiority of its lien.

The portion of that act which controls this question reads: "That in all cases where said prior lien or incumbrance or mortgage was given or executed for the purpose of raising money or funds with which to make such erections, improvements or buildings, then said lien shall be prior to the lien given by this act." Acts Ark. 1895, pp. 217, 220. The opinion of the majority makes it read: "That in all cases where said prior lien or incumbrance or mortgage was given or executed for money or funds which were actually used to make such erections, improvements or buildings, then said lien shall be prior to the lien given by this act;" or "that in all cases where said prior lien or incumbrance or mortgage was given or executed for the purpose of raising money or funds with which to make such erections, improvements or buildings, then said lien shall be prior to the lien given by this act, except in cases in which the money is not used for the purpose for which it was raised." But what warrant have the courts to substitute use for purpose in the statute of Arkansas or to add this exception to the act of its legislature? The legislature of Arkansas said nothing about the use or application of the money raised by these mortgages. That body declared that the purpose of the loan should determine its superiority. Why should the courts strike out the test which the legislature provided and insert another? It is said that this ought to be done to effect the intention of the legislature. But is the intention of that body in adopting a statute to be determined by the opinions of judges as to what it might or ought to have said, or is it to be found in that which is clearly expressed? Is it permissible for the courts to presume or believe that the legislature intended one thing when it clearly expressed another, and are courts allowed to substitute their presumption and belief for the actual legislation? The general rule that it is the purpose of the construction of statutes to learn and give effect to the intention of the legislative body which enacted them is familiar. But this rule is nothing but a broad general proposition, which is limited and qualified by the established rules and principles of the law that peremptorily prohibit the courts from imputing to any legislative body an intention, or from construing or interpolating into a plain statute the expression of an intention, which the legislature has not fairly set forth in the law which it has enacted. The proviso of section 3 which has been quoted is the only portion of this statute which states, or undertakes to state, the test which shall determine the superiority of the liens of prior mortgages over the subsequent liens of mechanics, and this proviso unequivocally declares that that test shall in all cases be the purpose for which the mortgage

was given. The provision of section 10 that any one interested as mortgagee or trustee may apply to a contractor or a subcontractor for a list of all the parties doing work or furnishing material for improvements and for a statement of the amount due to each of such persons does not seem to me to indicate that the legislature intended by that section to change the test it had plainly declared in section 3. If that body had such an intention it could easily have declared it, and section 10 contains no such declaration. In my opinion that section has two other objects: (1) To enable mortgagees whose mortgages were not given for the purpose of raising money to make the improvements to protect themselves against subsequent liens, an end which they could only attain by paying off such liens or causing them to be paid; and (2) to furnish a ready way for mortgagees to ascertain the names of the necessary parties to suits for the foreclosure of their mortgages. Whatever may have been its purpose, however, it contains nothing inconsistent with the plain declaration of the proviso of section 3, and, on familiar principles, an inconsistent intention and expression ought not to be construed into section 10 for the purpose of creating a conflict between that section and section 3, which the terms of those sections do not disclose. There is nothing in any of the sections of the act, nothing in the first, second, third, fourth, fifth, or tenth sections, to which the majority refer, which declares in terms that the purpose of the loan shall not be the test of its superiority or that the use of its proceeds shall be. There is nothing in any of these sections or in any part of the act inconsistent with the unambiguous declaration of the proviso of section 3, and therefore nothing, in my opinion, to warrant the repeal or modification of the plain words of that section. The following considerations persuade me to this conclusion:

1. It is the intention expressed in the statute, and that alone, to which courts may give effect. They may not assume or presume purposes and intentions that the terms of the statute do not indicate or express, and then enact provisions to accomplish these supposed intentions. A secret intention cannot be legally interpreted into a statute which is plain and unambiguous, and which does not express it. The legal presumption is that the legislature expressed its intention and its whole intention, that it intended what it expressed, and that it intended nothing more. *U. S. v. Wiltberger*, 5 Wheat. 76, 94, 5 L. Ed. 37; *Bennett v. Worthington*, 24 Ark. 487, 494; *Tynan v. Walker*, 35 Cal. 634, 95 Am. Dec. 152; *Alexander v. Worthington*, 5 Md. 471; *Maxwell v. State*, 40 Md. 293; *Smith v. State*, 66 Md. 215, 7 Atl. 49; *Johnson v. Southern Pac. Co.* (C. C. A.) 117 Fed. 462; *Insurance Co. v. Champlin* (C. C. A.) 116 Fed. 858; *Cold Blast Transp. Co. v. Kansas City Bolt & Nut Co.*, 52 C. C. A. 25, 114 Fed. 77, 81, 57 L. R. A. 696; *Railway Co. v. Bagley*, 60 Kan. 424, 431, 56 Pac. 759; *Woolsey v. Ryan*, 59 Kan. 601, 54 Pac. 664; *Davie v. Mining Co.*, 93 Mich. 491, 53 N. W. 625, 24 L. R. A. 357; *Vogel v. Pekoc*, 157 Ill. 339, 42 N. E. 386, 30 L. R. A. 491; *Campbell v. Lambert*, 36 La. Ann. 35, 51 Am. Rep. 1; *Turnpike Co. v. Coy*, 13 Ohio St. 84; *Stensgaard v. Smith*, 43 Minn. 11, 44 N. W. 669, 19 Am. St. Rep. 205.

In *U. S. v. Wiltberger*, 5 Wheat. 76, 94, 5 L. Ed. 37, Chief Justice Marshall said:

"The intention of the legislature is to be collected from the words they employ. Where there is no ambiguity in the words, there is no room for construction. The case must be a strong one, indeed, which would justify a court in departing from the plain meaning of words, especially in a penal act, in search of an intention which the words themselves did not suggest. To determine that a case is within the intention of a statute, its language must authorize us to say so. It would be dangerous, indeed, to carry the principle that a case which is within the reason or mischief of a statute is within its provisions, so far as to punish a crime not enumerated in the statute, because it is of equal atrocity or of kindred character with those which are enumerated."

It would not be less dangerous to strike down any or all liens of mortgages which are superior in date and right to mechanics' liens, and which are not denounced by a statute, because they are within the mischief which it was intended to remedy, or within its reason and are of a kindred character with those which it clearly enumerates and invalidates.

In *Maxwell v. State*, 40 Md. 293, the supreme court of that state said:

"Courts must not, even to give effect to what they may suppose to be the intention of the legislature, put upon the provision of a statute a construction not supported by the words, even although the consequence should be to defeat the object of the act."

In *Alexander v. Worthington*, 5 Md. 472, that court said:

"The courts cannot imagine an intent, and bend the letter of the act to it."

And again in *Smith v. State*, 66 Md. 215, 7 Atl. 49, it said:

"Even when a court is convinced that the legislature really meant and intended something not expressed by the phraseology of the act, it will not deem itself authorized to depart from the plain meaning of the language, which is free from ambiguity."

In *Tynan v. Walker*, 35 Cal. 634, the supreme court of California declared that the argument that the legislature intended to include a case that was not within the terms of a statute because it was within its reason was

—"A most dangerous and pernicious mode of reasoning, which amounts to judicial legislation, and overturns the maxim that courts are authorized to declare the law only, and not to make it. If they may add at all to the exceptions provided for in the statutes, under the pretense that the case before them is of equal equity with those given in the statutes, who is to fix the limit to their interpolation or establish the line between legislative and judicial function? If they may add one to the list of excepted cases, by a parity of reasoning they may add another, and so on until the entire body of the statute has become emasculated and the will of the judiciary substituted for that of the legislature. * * * It is an universal principle of construction that courts must find the intent of the legislature in the statute itself. Unless some ground can be found in the statute for restraining or enlarging the meaning of its general words, they must receive a general construction, and the courts cannot arbitrarily subtract from or add thereto."

And the supreme court of Arkansas, whose legislature enacted this statute, declared in *Ex parte Trapnall*, 6 Ark. 9, 12, 42 Am. Dec. 676, that:

"Effect must, if possible, be given to the object and intention of the legislature, but to ascertain that object and intention we must first have recourse

to the language employed in the act, and, if that be clear and unambiguous, we can proceed no further in the inquiry."

Apply the rule which these authorities announce to the statute in hand. It declares without uncertainty or doubt that the liens of prior mortgages whose proceeds were raised for the purpose of making improvements upon the mortgaged property are superior to subsequent mechanics' liens. It says "that in all cases where said prior lien or incumbrance or mortgage was given or executed for the purpose of raising money or funds with which to make such erections, improvements or buildings, then said lien shall be prior to the lien given by this act." The contention is that it intended to except from that declaration the liens of all such prior mortgages the proceeds of which were not actually used to make the improvements. In other words, the argument is that the legislature enacted that the purpose of the loan should be the test of its superiority when it intended to provide that the use of the loan should constitute that test. But the difference between purpose and use is patent in common parlance, in legislation, and in the law. Statutes which authorize the issue of municipal bonds invariably specify the purpose for which they may be issued and sold. If issued for that purpose they are valid; if for any other purpose, they are void. But it is a well-established principle, which has been uniformly and repeatedly sustained by the decisions of this court, that the fact that the proceeds of such bonds have not been used for the purpose for which they have been raised constitutes no defense to the bonds. The test of their validity is the purpose for which the proceeds were obtained, not the use to which they were applied. *City of Huron v. Second Ward Sav. Bank*, 30 C. C. A. 38, 43, 86 Fed. 272, 277, 49 L. R. A. 534; *National Life Ins. Co. v. Board of Education of City of Huron*, 10 C. C. A. 637, 644, 62 Fed. 778, 784; *West Plains Tp. v. Sage*, 16 C. C. A. 553, 566, 69 Fed. 943, 946; *Commissioners v. Beal*, 113 U. S. 227, 240, 5 Sup. Ct. 433, 28 L. Ed. 966; *Cairo v. Zane*, 149 U. S. 122, 137, 13 Sup. Ct. 803, 37 L. Ed. 673; *Maxcy v. Williamson County Court*, 72 Ill. 207. The legislature of Arkansas could not have been ignorant of the difference between purpose and use when it enacted this statute. It had undoubted power to choose whether the purpose of raising the proceeds of the mortgage loans or their use should determine the superiority of the liens of the mortgages. It chose and clearly provided that the purpose should constitute the test. This was a positive declaration that the use should not constitute it, for the expression of one alternative is the exclusion of the other, and it seems to me that it left no tenable ground for the position that the legislature intended that any other test than that which it plainly expressed should determine the superiority of the liens of such mortgages. The legal presumption becomes conclusive that the legislature meant what it so clearly expressed, and that it meant nothing else.

2. Where the legislature makes no exception from the plain terms of a statute, the conclusive legal presumption is that it intended to make none, and the courts may not lawfully do so. *Railway Co. v. B'Shears*, 59 Ark. 244, 27 S. W. 2; *Shreve v. Cheeseman*, 69 Fed. 785, 786, 16 C. C. A. 413, 414; *Madden v. Lancaster Co.*, 12 C. C. A.

566, 573, 65 Fed. 188; *Morgan v. City of Des Moines*, 8 C. C. A. 569, 60 Fed. 208; *McIver v. Ragan*, 2 Wheat. 25, 29, 4 L. Ed. 175; *Bank v. Dalton*, 9 How. 522, 528, 13 L. Ed. 242; *Vance v. Vance*, 108 U. S. 514, 521, 27 L. Ed. 808. In *Railway Co. v. B'Shears*, 59 Ark. 237, 244, 27 S. W. 2, the supreme court of Arkansas said:

"Where the statute makes no exceptions, the courts can make none. It might be very just and reasonable and right that the statute should make an exception, such as is contended it does make, or ought to be construed to make; but this was within the power of the legislature, 'and its exercise of the power cannot be restrained or varied by the courts to subserve' convenience, to relieve from hardships, or from requirements that seem unreasonable, or even absurd, where the language is plain and unambiguous. *Sims v. Cumby*, 53 Ark. 421, 14 S. W. 623; *McGaughey v. Brown*, 46 Ark. 87; *Railway Co. v. Hagan*, 42 Ark. 122; *Railroad Co. v. Carley*, 39 Ark. 246."

By the proviso of section 3 the legislature enacted that the liens of all prior mortgages which were given for the purpose of raising money to make improvements on the mortgaged property should be superior to the subsequent liens of laborers and materialmen. It made no exception of mortgages the proceeds of which were not actually used for the purpose for which they were raised. It therefore intended to make none, and it is not the province of the courts to do so. The legislature declared that the liens of all mortgages given for the purpose of raising money to make improvements should be superior to the subsequent liens of mechanics. That declaration seems to me to conclusively negative the assumption and decision of the majority that the legislature intended to and did provide that the liens of some of these mortgages should be superior, while the liens of others of them should be inferior to the subsequent liens of mechanics.

3. Construction and interpretation have no place or office where the terms of a statute are clear and certain and its meaning is plain. When its language is unambiguous, and its meaning evident, it must be held to mean what it plainly expresses, and no room is left for construction. In such a case argument from the reason, spirit, or purpose of the legislation, from the mischief it was intended to remedy, from history or analogy, for the purpose of searching out and justifying the interpolation into the statute of new terms, and for the accomplishment of purposes which the lawmaking power did not express, are worse than futile. They serve only to raise doubt and uncertainty where none ought to exist, to confuse and mislead the judgment, and to pervert the statute. *Lake Co. v. Rollins*, 130 U. S. 662, 670, 9 Sup. Ct. 651, 32 L. Ed. 1060; *U. S. v. Hartwell*, 6 Wall. 396, 18 L. Ed. 830; *Sturges v. Crowninshield*, 4 Wheat. 122, 4 L. Ed. 529; *Knox Co. v. Morton*, 15 C. C. A. 671, 673, 68 Fed. 787, 789; *Railroad Co. v. Sage*, 17 C. C. A. 553, 565, 71 Fed. 40, 47; *Webber v. Railway Co.*, 38 C. C. A. 79, 83, 97 Fed. 140, 144; *Swarts v. Siegel* (C. C. A.) 117 Fed. 13; *Johnson v. Southern Pac. Co.* (C. C. A.) 117 Fed. 462; *U. S. v. Fisher*, 2 Cranch, 358, 399, 2 L. Ed. 304; *Bedsworth v. Bowman*, 104 Mo. 44, 49, 15 S. W. 990; *Warren v. Paving Co.*, 115 Mo. 572, 576, 22 S. W. 490; *Davenport v. City of Hannibal*, 120 Mo. 150, 25 S. W. 364; *Witte v. Koeppen*, 11 S. D. 598, 79 N. W. 831, 74 Am. St. Rep. 826; *Johnson v. Railroad Co.*, 49 N. Y. 455, 462.

In *Lake Co. v. Rollins*, 130 U. S., at page 670, 9 Sup. Ct. 652, 32 L. Ed. 1060, the supreme court in discussing this question said:

"We are unable to adopt the constructive interpolations ingeniously offered by counsel for defendant in error. Why not assume that the framers of the constitution and the people who voted it into existence meant exactly what it says? At the first glance, its reading produces no impression of doubt as to the meaning. It seems all sufficiently plain, and in such a case there is a well-settled rule which we must observe. The object of construction, applied to a constitution, is to give effect to the intent of its framers and of the people in adopting it. This intent is to be found in the instrument itself; and when the text of a constitutional provision is not ambiguous the courts, in giving construction thereto, are not at liberty to search for its meaning beyond the instrument. To get at the thought or meaning expressed in a statute, a contract, or a constitution, the first resort, in all cases, is to the natural signification of the words, in the order of grammatical arrangement in which the framers of the instrument have placed them. If the words convey a definite meaning, which involves no absurdity, nor any contradiction of other parts of the instrument, then that meaning, apparent on the face of the instrument, must be accepted, and neither the courts nor the legislature have the right to add to it or take from it. *Newell v. People*, 7 N. Y. 9, 97; *Hills v. City of Chicago*, 60 Ill. 86; *Scott v. Reid*, 10 Pet. 524, 9 L. Ed. 519; *Leonard v. Wiseman*, 31 Md. 201, 204; *People v. Potter*, 47 N. Y. 375; *Cooley, Const. Lim.* 57; *Story, Abr. Const.* § 400; *City of Beardstown v. City of Virginia*, 76 Ill. 34. So, also, where a law is expressed in plain and unambiguous terms, whether those terms are general or limited, the legislature should be intended to mean what they have plainly expressed, and consequently no room is left for construction. *U. S. v. Fisher*, 2 Cranch, 358, 399, 2 L. Ed. 304; *Doggett v. Railroad Co.*, 99 U. S. 72, 25 L. Ed. 301."

If the English language contains any words or terms which would express more clearly than those used in the act of 1895 the thought that the purpose for which a prior mortgage or incumbrance was given shall be the sole test of its superiority over subsequent mechanics' liens, they do not occur to me. This seems to me to be the evident and the only meaning of the words of the statute when they are taken in their natural and ordinary signification. They say "that in all cases where said prior lien or incumbrance or mortgage was given or executed for the purpose of raising money or funds with which to make such erections, improvements, or buildings, then said lien shall be prior to the lien given by this act." In my opinion, the courts ought not to repeal this law and enact another to the effect that the purpose of the giving of the prior mortgages shall not be the test of their superiority, and that the use of their proceeds or some other fact or circumstance shall be. No such duty is imposed upon them, nor is any such legislative power conferred upon the judiciary.

4. The common or the general law is not further abrogated by a modifying statute than the clear import of its language necessarily requires. Such a statute should be strictly interpreted, and should not be extended by construction to subjects or classes which it does not clearly include. *Shaw v. Bank*, 101 U. S. 557, 565, 25 L. Ed. 892; *Fitzgerald v. Quann*, 109 N. Y. 441, 445, 17 N. E. 354; *Brown v. Barry*, 3 Dall. 365, 367, 1 L. Ed. 638; *Johnson v. Southern Pac. Co. (C. C. A.)* 117 Fed. 462. Under the common law and under the statutes of Arkansas as they read before this act of 1895 was passed, the liens of all mortgages and incumbrances upon real estate before im-

provements were commenced thereon took precedence in right as in time to the subsequent liens of mechanics. The act of 1895 subordinated the liens of that class of these prior mortgages and incumbrances which were not given for the purpose of raising money to make improvements upon the incumbered property to subsequent mechanics' liens. To that extent it abrogated the common law and the general law. It ought not to be construed to abrogate or modify that law further than its language necessarily requires. That language does not require the abrogation of the former law to such an extent that the liens of that class of mortgages which were given for the purpose of raising money to make improvements, but the proceeds of which were not used for that purpose, shall be subordinated to subsequent liens of mechanics in addition to the class specified in the statute, and it ought not to be given that effect.

5. An *ex post facto* construction of a plain statute which destroys prior rights vested under the law as it reads is as abhorrent to justice and reason and as inadmissible as an *ex post facto* law. *Johnson v. Southern Pac. Co.* (C. C. A.) 117 Fed. 462. The mortgagees in this case invested their money in this mortgage for the purpose specified in this statute, which plainly declares that the liens of mortgages given for that purpose shall be superior to the subsequent liens of mechanics. A construction which repeals that declaration establishes a new test for the superiority of such liens, and strikes down those honestly secured under the statute, without any notice or premonition that any new test not mentioned in this law would be prescribed by the courts, has all the pernicious attributes of an *ex post facto* law, and is violative of the basic principles of Anglo-Saxon jurisprudence.

In view of the unquestioned rules and principles to which reference has now been briefly made; because it is the intention expressed in the statute, and that alone, to which courts may lawfully give effect, and this statute does not express an intention to except from its terms prior mortgages given for the purpose of raising money to make improvements upon the mortgaged property the proceeds of which were not used for that purpose; because the legislature has made no exception from the plain terms of the statute, and when it makes none the conclusive legal presumption is that it intended to make none, and the courts ought not to do so; because the terms of this statute are plain and unambiguous, and for that reason it is not subject to construction; because it abrogates a part of the common and of the general law, its language does not require the abrogation of that part of the law which gives superiority to the liens of prior mortgages given for the purpose of raising money to make improvements on the mortgaged property the proceeds of which were actually used for other purposes, and a statute which changes the general law may not be construed to modify it further than the clear import of its language necessarily requires; and because the construction which would repeal the test of the purpose of a loan prescribed by a statute and enact the test of its use to destroy mortgages previously given in reliance upon the plain declaration of the law that the purpose, and not the use, is the test, has all the vice of an *ex post facto* law,—the conclusion is irresistibly forced upon my mind that the exception to the terms of this statute

which the opinion of the majority inserts ought not to be construed into the law by the courts, and the statute should stand and be enforced as it was enacted by the legislature, with its plain declaration that the sole test of the superiority of liens upon lands before improvements are made is the purpose for which the debts they secure were incurred, and not the use made of their proceeds.

My conclusion relative to the question which has been discussed is based upon the reasons which have now been given. The statute seems to me too plain for interpretation, and arguments from the mischief to be remedied and the probable intention of the legislature seem to me ineffectual. It may not, however, be out of place to suggest that it is exceedingly doubtful whether the change in the terms of the statute, that the use of the proceeds of loans instead of the purpose for which the proceeds were obtained shall be the test of the superiority of the mortgages which secure them, will not prove very deleterious to the interests of mechanics, laborers, and materialmen who contribute to the construction of improvements upon mortgaged real estate. Under the test which the statute prescribes they have notice of the existence of prior incumbrances from the records, and by a simple inquiry of the holders of these instruments and of the owner of the property they may readily ascertain before they bestow their labor or material upon the improvement whether or not the incumbrances will be superior to their liens. They can easily learn the purpose for which the money was raised. If they discover that it was obtained for the purpose of making the improvement, they may refuse to contribute to the building, and may thus secure themselves against loss in any event. They cannot do so if the use or application of the proceeds is substituted for the purpose of the loan as the test of the superiority of the mortgages. Under that test the liens of prior incumbrances, which are not superior when the improvement is commenced, may, by the use of their proceeds in its construction, become superior as the building rises. A contractor or laborer will be unable to learn before he commences to contribute to the improvement what part of the proceeds of prior liens will be used in the construction of the building, and after he has furnished his material or performed his labor the proceeds of prior mortgages may be used in completing it, and thus superior liens may be fastened upon it which had not attached or become fixed when he contributed to the building, and which will ultimately sweep away all his security.

There is another consideration which ought to have weight to prevent this change in the statute. It is that such a change will render the security of mortgages more precarious and uncertain and will tend to compel borrowers to pay higher rates of interest to compensate for the less security of the mortgage liens. While these considerations are not in my opinion appropriate to the discussion of this question in the courts, they are worthy of serious deliberation by the legislature or by any other body which undertakes to change the terms and effect of this statute.

There is another conclusion of the court to which I am unable to assent. It is that the mortgagees were estopped from claiming that they had a lien even for the \$3,000, which was actually invested in the

improvement, superior to that of Dyke Bros., notwithstanding the fact that their loan was made and their mortgage was recorded before the lien of the latter attached. The facts disclosed by the record upon which this conclusion is based are these: Harry E. Kelley was a broker and an agent for owners of real estate and for parties borrowing and loaning money in the city of Ft. Smith, in the state of Arkansas, where the mortgagor, Joe P. Matthews, resided. The mortgagees appear to be nonresidents of the state. Matthews made a written application to Kelley to procure for him a loan of \$4,000 on his lot. By this application he appointed Kelley his agent, agreed to pay him for his services in procuring the loan, and that it was to be procured for the purpose of building a two-story stone or brick wholesale house upon the lot. Kelley obtained the loan of the mortgagees, and Matthews paid him out of the proceeds \$200 for his services. For some ten years prior to this time Kelley had been the agent of the mortgagees to collect and foreclose their mortgages in the state of Arkansas, and had procured loans from them for borrowers who had appointed him their agent for that purpose by submitting to the mortgagees the written applications of the borrowers of the character made by Matthews in this case. This application was submitted to the mortgagees before they made the loan, and after it was accepted by them Matthews made his notes and mortgage on April 28, 1899. At the time when the mortgage was made Kelley placed the \$4,000, which Matthews borrowed, to the credit of Matthews on his books, and subsequently paid it out on Matthews' orders. There was no evidence that the mortgagees had or exercised any control over the disposition of the money after the mortgage was made, on April 28, 1899, and the proof was undisputed that it was paid out upon the orders of Matthews. There was no understanding and agreement between Kelley and the mortgagees that the former should apply the money to the building of the house. But Matthews did not ask for the payment of all the money to him, all the parties to the transaction knew that it was borrowed for the purpose of erecting the house, and Kelley intended to see that it was applied to that purpose, for this was his practice when his customers borrowed money for the purpose of improving the property which they mortgaged. The lien of Dyke Bros. first attached to the property on June 19, 1899, more than a month after the mortgagees had transferred to Matthews the entire control of the money loaned and had recorded their mortgage. There is no controversy concerning the facts which have now been recited. But there is a direct conflict of testimony between two witnesses, M. T. Dyke and Harry E. Kelley, over the essential fact upon which Dyke Bros. relied to maintain their estoppel, and which is now to be considered. Mr. Dyke testified that after he procured the contract to furnish some of the lumber for this building, and before he delivered any of it, he asked Kelley: "What about the pay on it?" and he says, "I have about \$1,500 in my hands belonging to Mr. Matthews, and I will see that you get your money out of it;" that he would not have furnished the lumber unless Kelley had made this statement, and that he did furnish it in reliance upon this conversation. Mr. Kelley testified that he never had any such conversation with Dyke, and that he never made

any such statement to him, and there is no other evidence in the case on the subject. The referee who heard these witnesses, observed their demeanor, and weighed their characters found that no such conversation took place, and that if it had it could not have estopped the mortgagees from insisting that the lien of their mortgage was superior to that of Dyke Bros. The district court reversed the finding of fact and conclusion of law of the referee, and rendered the decree which has been recited. Was this action warranted by the law and the evidence when this case came before the district court?

Let us consider first the question of fact. The mortgage was of record. The question whether or not this conversation took place had been submitted to and was decided by the referee under an agreement of the parties that he should determine all the questions of law and of fact relative to the superiority of their liens. The burden of proof was on Dyke Bros. to establish the conversation on which they relied by a fair preponderance of testimony, and they had no preponderance, for Kelley's testimony stands uncontradicted in the case by any witness except Dyke. More credence is and ought to be given to a disinterested than to an interested witness, and Kelley had no interest while Dyke's claim was at stake upon his testimony. The finding of a fact dependent upon conflicting testimony by a judge, a master, or a referee, who sees and hears the witnesses testify, has every reasonable presumption in its favor, and may not be set aside and modified unless it clearly appears that there was an error or mistake upon his part. *Tilghman v. Procter*, 125 U. S. 136, 149, 8 Sup. Ct. 894, 31 L. Ed. 664; *Callaghan v. Myers*, 128 U. S. 617, 666, 9 Sup. Ct. 177, 32 L. Ed. 547; *Clyde v. Railroad Co.* (C. C.) 59 Fed. 394, 399; *Missouri Pac. Ry. Co. v. Texas & Pac. Ry. Co.* (C. C.) 33 Fed. 803, 806; *Hennessey v. Budde* (C. C.) 82 Fed. 541, 542.

And where by agreement of the parties a referee or special tribunal is selected, or by consent parties submit to him their controversies for determination, his finding of the facts "so far as it depends upon conflicting testimony, or upon the credibility of witnesses, or so far as there is any testimony consistent with the finding, must be treated as unassailable." *Davis v. Schwartz*, 155 U. S. 631, 636, 637, 15 Sup. Ct. 237, 39 L. Ed. 289; *Kimberly v. Arms*, 129 U. S. 512, 9 Sup. Ct. 355, 32 L. Ed. 764; *Crawford v. Neal*, 144 U. S. 585, 596, 12 Sup. Ct. 759, 36 L. Ed. 552; *Furrer v. Ferris*, 145 U. S. 132, 12 Sup. Ct. 821, 36 L. Ed. 649. The holders of these liens selected this referee as a special tribunal, and consented that the questions of fact and of law, which conditioned the rank of their liens, should be determined by him, and the rule announced by the supreme court in *Davis v. Schwartz* made his finding of fact here, which was supported by at least as much testimony as was deduced in opposition to it, conclusive of this issue. *Kimberly v. Arms*, 129 U. S. 512, 9 Sup. Ct. 355, 32 L. Ed. 764, and *Davis v. Schwartz*, 155 U. S. 637, 15 Sup. Ct. 237, 39 L. Ed. 289. In the latter case the supreme court after declaring that a finding of fact in such a case was conclusive if there was any testimony to sustain it, and after discussing and reiterating the rule in *Kimberly v. Arms*, disposed of a like question which had arisen in that case in these words: "As the reference in this case was by consent

to find the facts, we think the rule in *Kimberly v. Arms* applies, and, as there is nothing to show that the findings of fact were unsupported by the evidence, we think they must be treated as conclusive." It seems to me to follow from these rules and decisions that whether the occurrence of the conversation upon which Dyke Bros. claim an estoppel is founded is considered as an original question, dependent upon the preponderance of evidence, and upon the interest, character, and demeanor of the witnesses, or as the finding of the referee whom the parties had selected and agreed to constitute a special tribunal to hear and determine their controversies, the finding of the referee that no such conversation took place was both right and conclusive, and should have been sustained by the court below.

Nor is the conclusion of law that if this conversation had taken place the mortgagees would have been estopped thereby from maintaining the superiority of their lien more tenable. An estoppel is a prohibition of one from denying the truth of some statement or representation of fact which he has made and upon which another has rightfully acted. It is nothing more and goes no further. It never prevents one from maintaining the truth concerning any fact relative to which he has made no misstatement or misrepresentation. The truth which Dyke Bros. seek to estop the mortgagees from asserting is that the lien of their mortgage was superior to the mechanic's lien of Dyke Bros. That mortgage was of record, and Dyke Bros. were charged with knowledge of its priority and superiority. The mortgagees never made any statement or representation that it was not or would not be prior or superior to the lien of these materialmen. Kelley had neither power nor authority to discharge the lien of the mortgagees nor to subordinate it to the liens of others, and no statement or representation which he made could have had any such effect or could have been binding upon them.

Again, if Kelley had been the mortgagee and had made the alleged statement to Dyke, still he would not have made any statement or representation that the lien of the mortgagees was not superior to that of Dyke Bros. If he said, "I have about \$1,500 belonging to Mr. Matthews, and I will see that you get your money out of it," that statement contained no averment or representation that the lien of the mortgagees was not superior to any lien which Dyke Bros. had or could acquire upon the lot and building. It was nothing but a statement that he had \$1,500 of Matthews' money, coupled with a promise that he would pay Dyke Bros. out of it. It would not be a denial of this statement to prove the first lien of the mortgagees upon the lot and building. That fact tends in no way to show that Kelley did not have \$1,500, or that he would not see that Dyke Bros. were paid. Hence the statement cannot estop or prohibit the mortgagees from establishing and maintaining the fact that their lien is superior to that of Dyke Bros., a truth which is neither directly nor indirectly denied by the terms of Kelley's alleged statement.

Moreover, there is no foundation for an estoppel in the statement. It is not claimed that the averment that Kelley had \$1,500 of Matthews' money in his hands was not true. The only part of the conversation which is asserted to be false or to form the basis of an estop-

pel consists in the words, "I will see that you get your money out of it." But this is nothing but a promise, nothing but an executory agreement, and no estoppel can arise upon a promise or upon an executory contract coupled with a failure to perform it. The only remedy for such a failure is an action for specific performance or for damages for breach of the agreement. 2 Pom. Eq. Jur. § 808; Bigelow, Estop. p. 555; White v. Ashton, 51 N. Y. 285; Starry v. Korab, 65 Iowa, 267, 269, 21 N. W. 600; Railroad Co. v. Barnes, 64 Fed. 80, 82, 12 C. C. A. 48, 50.

A false representation or a concealment of an existing or present state of things is a sine qua non of an estoppel. Neither a promise nor a prophecy will sustain it, "for," as Mr. Bigelow well says, "if a party make a representation concerning something in the future it must generally be either a mere statement of intention or opinion, uncertain to the knowledge of both parties, or it will come to a contract with the peculiar consequences of a contract." In Maddison v. Alderson, 52 Law J. Q. B. 737, Lord Selborne said: "The doctrine of estoppel by representation is applicable only to representations as to some state of facts alleged to be at the time actually in existence, and not to promises de futuro, which, if binding at all, must be binding as contracts." So are all the authorities. There was no false statement, no misrepresentation of any fact, of any past or existing state of things, in the alleged conversation of Kelley, and hence it could not have worked an estoppel. The conclusion seems to me to be inevitable that under the evidence and the finding of the referee Dyke Bros. failed to establish the fact that Kelley made the statement upon which they relied, and that, if he had made it, it could not under the law have estopped the mortgagees from asserting the priority and superiority of their lien. No estoppel arose which forbade them from maintaining that the lien of their mortgage was superior in right to the mechanic's lien of Dyke Bros.

In my opinion the decree below should be reversed, with a direction to the court below to enter a decree in accordance with the finding of the referee that the mortgagees are entitled to a first lien upon the premises and the proceeds thereof for the entire amount of their mortgage debt and interest.

SOELBERG et al. v. WESTERN ASSUR. CO. OF TORONTO, CAN.

SAME v. THAMES & MERSEY MARINE INS. CO., Limited.

(Circuit Court of Appeals, Ninth Circuit. October 6, 1902.)

Nos. 748, 749.

1. MARINE INSURANCE—ACTION ON POLICY—EVIDENCE.

The plaintiff, in an action on a marine insurance policy, having the burden to prove a loss from a cause and to an amount that will authorize a recovery under the terms of the policy, such amount must necessarily be what remains after all proper deductions have been made, and the defendant may properly be allowed to show, on cross-examination of plaintiff's witnesses, the existence of liens on the vessel which were a charge on plaintiff's interest, not disclosed by their testimony in chief.

2. SAME—ACTION ON POLICY—SUFFICIENCY OF EVIDENCE.

Under the settled rule that, to entitle an insured to recover on a marine policy of insurance, the burden rests upon him to prove a loss from a cause insured against, and for an amount which renders the insurer liable under the terms of the policy, where a policy provides that the insured shall not have the right to abandon the vessel unless the amount which the company would be liable to pay under an adjustment as a partial loss "shall exceed half the amount hereby insured," and also that no partial loss shall in any event be paid unless amounting to at least 5 per cent. net, the insurer does not meet such burden of proof merely by evidence that the vessel received such injury during a voyage that she was obliged to seek a port of refuge, and that her value when repaired would not equal the cost of the repairs. To establish either a constructive total loss, which gave the insured the right of abandonment, or even a partial loss, under such policy, there must be evidence from which a jury could find that the loss occurred from a peril insured against, and the amount of damage which resulted from such peril, as distinguished from such as may have resulted from the defective condition of the vessel, attributable to wear and tear or other ordinary causes; and this, whether the amount of loss to fix liability or to authorize abandonment is measured by the amount of the insurance or the valuation of the vessel.

3. SAME—ACCEPTANCE OF ABANDONMENT—ACTS DONE UNDER SUE AND LABOR CLAUSE.

Under the sue and labor clause of a marine policy, expressly providing that acts of the insured or insurer in recovering, saving, and preserving the property insured in case of disaster shall not be considered a waiver or an acceptance of an abandonment, where the insurer specifically refused to accept an abandonment of the insured vessel after she became disabled the action of its agent, in co-operating with the master in making temporary repairs, in assuming responsibility for removing the vessel to another port, and in procuring the money to pay the expense of such removal, which was furnished on a bottomry bond executed by the master, did not operate as an acceptance of the abandonment.

4. SAME—ACCEPTANCE OF PREMIUM AFTER NOTICE OF LOSS.

The fact that the insurer of a vessel demanded and accepted payment of a premium note after receiving notice of loss and of abandonment does not relieve the insured from the necessity of proving the loss to entitle him to recover on the policy.

In Error to the Circuit Court of the United States for the Northern Division of the District of Washington.

These are actions at law to compel the payment of marine insurance. The parties hereto stipulated as follows: "That these two cases may be heard together; that there be no part of the record of the case against the Thames & Mersey Marine Insurance Company, Limited, printed, save and except the pleadings and bills of exceptions; that the record in both cases be printed as one record, to apply equally to either case; and that only one brief be required, which shall be a discussion of both or either of the cases, as may be applicable."

Plaintiffs in error make the following statement of facts: "A. H. Soelberg, for and as trustee of the Seattle & Alaska Steamship Company, having an insurable interest in the steamship City of Columbia, procured insurance from each of the defendants in error herein. The Western Assurance Company insured \$15,000, on account of whom it may concern, in case of loss to be paid to A. H. Soelberg, for one year from August 25, 1898, upon his or their interest in the body, machinery, tackle, apparel, and other furniture of the ship, valued at \$70,000. The total premium was \$1,500, of which \$600 was paid in cash and notes delivered for the deferred premium. The Thames & Mersey Marine Insurance Company insured \$5,000 on account of A. H. Soelberg for the same period 'upon his or their interest' in the same steamer,

valued at \$80,000. The Thames & Mersey policy has on its margin the words, 'The insured value shall be taken as the repaired value of the vessel in ascertaining whether there is a constructive total loss under this policy.' In other respects the policies are substantially similar. The total premium under this policy was \$600, of which \$150 was paid in cash, and the balance evidenced by three notes for \$150 each, payable, respectively, November 30th, February 30th, and May 30th following. The defendants at the time of issuing the policies were informed of and knew the interest of the Seattle & Alaska Steamship Company in the ship, and of the trust relation of Soelberg, in whose name the policies were issued. August 26, 1898, the vessel being staunch, sound, and seaworthy, having had repairs amounting to \$43,000 placed upon her immediately prior thereto, sailed from Seattle on her voyage to Honolulu, and on the 29th of October following, still staunch, sound, and seaworthy, she sailed from Honolulu on her return voyage; and on or about the 30th or 31st day of October she encountered heavy trade winds and cross-seas, which greatly increased in violence as the vessel proceeded on her course, which caused her to strain, pitch, and toss heavily; her seams opened up between her boilers and amidships, and water began to come in through the sleeve of the stern bearing and through her deadwood; her two after boilers on the port side became loose in their saddles; her bulkheads had torn from the starboard side, and worked with the swaying of the ship, leaving a gap about three inches wide between the after bulkhead and side of the ship; the main steam pipe, of about thirteen inches in diameter, leading from the superheater, had torn loose from the stirrups which held it to the beams overhead, and was supported only by the superheater at one end and the engines at the other; the deck seams had opened, and on one side of the vessel oakum was streaming from some of her butts, and in one place her deck had opened across the ship, and the canvas was ruffling up; she was working badly, and was severely strained; not a door in the after cabin could be closed; she was hogged, her stern and bow dropping, thus causing the shaft to press and crowd against the sleeve of the stern bearing, thereby creating friction to such an extent as to cause the water leaking through at this place to come in hot. She was making three feet of water per hour, which was equal to the full capacity of her pumps. She was in danger of breaking up, whereupon the master called a consultation of his officers at 8 a. m. on October 31st, at which consultation Capt. John Barneson, superintendent of marine transportation United States army, who was a passenger on the vessel, was invited to and did take part therein. The result of the consultation was the conclusion that it was impossible for the ship to weather the storm, that the winds and waves were increasing, and that it was necessary to put back. Accordingly, on the same day, the master put back, and about 4 a. m. of November 2d reached the port of Hilo, H. I., in distress. Having dropped anchor in the harbor of Hilo, the master made due and timely protest, and afterwards extended protest. The U. S. consular agent at this port appointed a board of survey, consisting of three competent and experienced master mariners, who reported the vessel totally unfit and unseaworthy and unrepairable, except at a cost in excess of her value when repaired. Thereupon plaintiffs in error abandoned their interest in the vessel to the underwriters, and furnished them with proof of interest and loss. Defendants declined to accept abandonment, but sent an agent to Hilo, who assumed full direction and control of the vessel, and after putting some repairs on her caused her to be taken to Honolulu, avowedly for complete repairs. The expense of the repairs placed on the vessel in Hilo preparatory to taking her to Honolulu was raised by said agent, who caused a bottomry bond to be put on the boat for this purpose. After arriving at Honolulu she was left in charge of the agent aforesaid by the master, who returned without her to Seattle. While at Honolulu she was libeled by the crew for wages, including the amounts accruing subsequent to abandonment, and was never returned to plaintiffs in error. Defendants declining to pay any sum, plaintiffs commenced action against them separately upon their respective policies."

To sustain the issues on behalf of plaintiffs, the policy of insurance was admitted in evidence, and also the contract of purchase.

The testimony of plaintiff A. H. Soelberg shows: That the said contract was taken in his name merely as a matter of convenience, and no one else was interested in it besides the Seattle & Alaska Steamship Company; that his position was that of a mere go-between between Alexander Baillie and the Seattle & Alaska Steamship Company; whatever he did he did for the Seattle & Alaska Steamship Company, and as an officer of that company, and not in his own interest in any wise; that he was trustee for said corporation, and as such trustee took out said policy for its sole benefit; that the agents of the defendant, through whom said insurance was procured, were informed and knew at the time of the interest of the said Seattle & Alaska Steamship Company in said vessel, and of the relation of the said Soelberg, and for whose benefit the same was procured.

The policy, in terms, provides: "(1) In case of loss, same to be paid in sixty days after proof and adjustment of loss and proof of interest in said vessel (the amount of the notes given for premium, if unpaid, being first deducted, and all sums due or coming due to the company from the insured being first paid or secured to the satisfaction of the insurers), but no partial loss or particular average shall in any event be paid under this policy, unless amounting to at least five per cent. net. * * * (3) Touching the adventures and perils which this insurance company is contented to bear and takes upon itself in this policy, they are of the seas; * * * and all other losses and misfortunes that shall come to the hurt or damage of the vessel hereby insured, or any part thereof, to which insurers are liable by the rules and customs of insurance in San Francisco, including the rules for adjustment of losses printed on the back thereof, and the provisions of the Civil Code of California, excepting such losses and misfortunes as are excluded by this policy. (4) Not to use any ports or places on the west coast of the United States of America, south of San Francisco, except * * *. It shall and may be lawful, however, for said vessel in her voyages to proceed and sail to, touch and stay at, any ports or places, if thereunto obliged by stress of weather or other unavoidable accidents, without prejudice to this insurance. * * * (6) This company is not to be held liable, in general average or otherwise, for jettison of deck cargo, unless the vessel is stranded; nor for wages and provisions, except when the same are a general average charge by the custom of the port of destination; nor in case of insurance upon a steamer for any injuries to the machinery or boiler, nor for loss or damage to the vessel itself caused by the explosion of boilers, unless occasioned by stranding, striking the ground, sinking, burning, or collision with another vessel; nor for fuel, wages, or provisions, or expense of delay consequent upon repairs of any kind on any steamer, except in general average for wages and provisions of that portion of the crew absolutely necessary for the navigation of the vessel; nor for any claim for loss or expense arising from capture, seizure, detention, destruction. * * * (7) In case of any loss or misfortune resulting from any peril insured against, the party insured hereby engages, for himself or themselves, his or their factors, servants, and assigns, to sue, labor, and travel, and use all reasonable and proper means for the security, preservation, relief, and recovery of the property insured or any part thereof, and also to use all proper and legal means to recover, through general average or otherwise, from the parties interested in freight or cargo, either or both, any and all sums due to the vessel or its owners on account of sacrifices, losses, or expenses incurred for the general safety or the common good, to the charges whereof this company will contribute in proportion as the sum insured is to the whole sum at risk; nor shall the acts of the insured or insurers in recovering, saving, and preserving the property insured, in case of disaster, be considered a waiver or an acceptance of an abandonment. (8) It is agreed that one-third shall be deducted from the cost of all repairs of injuries and losses on the vessel by the perils insured against (except on anchors, copper, and calking under the copper), as a commutation for the average difference between new and old; the remains of all articles replaced being considered as salvage, and their proceeds deducted from the gross loss. * * * (9) It is also agreed that the insured shall not have the right to abandon the vessel, unless the amount which this company would be liable to pay under an adjustment, as of partial loss for

labor and materials (exclusive of salvage or general average expenses and costs of funds), shall exceed half the amount hereby insured; and when the vessel is in a port or place where she can lie in safety she shall in no case be sold for or on account of the insurers, until the estimated cost of repairs shall have been communicated to them and their consent to the sale obtained. And, in case of the total loss of the vessel with salvage, the amount allowed out of the salvage to the officers and crew for wages earned or services rendered previously to the loss shall be considered as so much of the salvage applied to the use of the shipowners, even though the same should be allowed or paid under the name of salvage, and not as wages, and shall accordingly be deducted in adjusting a loss. * * *

Among the rules for adjustment of marine losses under the San Francisco policy, indorsed upon the back of the policy, in this case are the following: "Rule 6. Surveys. The insurers shall not be obliged to accept any adjustment on a vessel based upon a survey which omits to discriminate between the repairs attributable only to the perils insured against and such repairs as are due only to wear and tear, or to the original defects, natural decay, or depreciation of the vessel. Rule 7. Bill for Repairs. When bills for repairs are presented which include items indifferently specified, chargeable partly to owners and partly to underwriters, and having no reference to discriminations in the survey, the adjuster shall require the claimant or master to separate the charges in accordance with the survey. Failing wherein, the adjuster shall refer the bill back to the maker thereof, with a request to separate the items so as to correspond with the survey. Failing in both, it shall be the custom to charge the whole of the unspecified items to the 'Owners' column."

There are eight assignments of error: (1) The court erred in overruling the objection of the plaintiffs to the questions propounded to the witness John P. Jacobson, manager, by the defendant's counsel on cross-examination, which questions and answers are as follows: "Q. When you met her (the vessel) down in Honolulu before she started out on the voyage from Honolulu to Seattle, she got into some business difficulty, did she not? A. Yes. Q. Did you, together with the master, on behalf of Mr. Soelberg, give any security for the money or bonds that were necessary to be raised down there? A. I gave a bottomry bond on the boat. Q. After the vessel had put into Hilo, where did she go next? A. She went from there to Honolulu. Q. While you were at Honolulu was there any action taken by the crew with respect to the collection of their wages? A. I believe there was. Q. What was that? A. I think they filed a libel on the vessel." (2) And in overruling the objection of the plaintiffs to the introduction by the defendant upon cross-examination of Walter S. Milnor, master of said ship, of defendant's Exhibit 1 in evidence, said exhibit being known as or called the "Bottomry Bond." (3) The court erred in overruling the objection of plaintiffs to the question propounded to said master, Capt. Milnor, upon cross-examination, and in admitting the evidence of said Milnor on cross-examination, the full substance of which said evidence is as follows: "That when said master finally left the city of Columbia, in Honolulu, about the 12th of December, 1898, there was due the crew of said ship at said time the sum of about \$10,000." (4) In overruling the objection of plaintiff and in admitting evidence of said Milnor in cross-examination, as follows: "Q. I am only asking for liens at the time you left Honolulu with the ship for Seattle. A. The crew's wages were not then due, sir. There was nothing. Q. There were unpaid wages, were there not, for the voyage down? * * * I want the amount that was earned. A. There was an amount earned, of course, that had not been paid when we left Honolulu for Seattle. Q. How much was it? To which witness then answered substantially that he could only estimate the amount by figuring the monthly wages of the crew; that he did not know whether these monthly wages amounted to \$3,000 or \$4,000 per month; and that they had not been paid." (5) That the court erred in denying the motion of plaintiff to strike out all the evidence of Capt. Milnor concerning wages earned and not paid at the time of the departure of the ship from Honolulu for Seattle. (6) The court erred in sustaining the objection of the defendant to the question propounded to the witness Capt.

Whitney, as follows: "Q. Considering the difference in value between new for old, what would you say as to the comparative cost of the repairs with her value as repaired?" (7) "The court erred in granting the motion of the defendant at the close of the plaintiff's case for a peremptory instruction to the jury to find a verdict for the defendant, and in so instructing the jury so as to find, and in receiving said verdict so found and signed by the jury." (8) The court erred in rendering the judgment herein.

Ballinger, Ronald & Battle, for plaintiffs in error.

Nathan H. Frank and J. M. Ashton, for defendant in error.

Before GILBERT and ROSS, Circuit Judges, and HAWLEY, District Judge.

HAWLEY, District Judge, after making the foregoing statement, delivered the opinion of the court.

A marine insurance is an insurance against risks connected with navigation to which a ship, cargo, freight, or other insurable interest in such property may be exposed during a certain voyage or a fixed period of time. On September 1, 1898, the Western Assurance Company of Toronto, Canada, the defendant in error herein (which will be hereafter designated as the defendant), insured the steamer City of Columbia for the sum of \$15,000, under a time policy for the year ending August 25, 1899. In this policy the steamer was valued at \$75,000. The controlling provisions in the policy are set forth in the statement of facts. On behalf of the plaintiffs in error testimony was given at the trial tending to show that the value of the ship would not be worth repairing; that the value after repairing would not warrant the costs of repair. After plaintiffs had rested their case, counsel for defendant moved "for a peremptory instruction to the jury to find a verdict for the defendant on the ground that the plaintiffs failed to prove a constructive total loss, within the terms of the policy; and upon the further ground that the insured had not made, and could not make, an abandonment of said vessel; and, because of their own acts in creating liens upon said vessel, other parties have interests which the owner could not sacrifice by an abandonment,"—which motion was granted by the court, and the jury rendered verdict accordingly, upon which judgment was rendered in favor of defendant for its costs.

Did the court err in giving this instruction to the jury? This is the vital point involved in the assignments of error. Other questions are presented therein as to the alleged errors in the admission of certain testimony, allowance of motions, etc., which will be first considered.

The assignments of error 1 to 5, set forth in the statement of facts, are based upon the proposition that the defendant should not, on cross-examination, have been permitted to ask questions tending to show that there were liens upon the vessel which were a charge against the owners instead of the underwriters. We are of opinion that the court did not err in allowing the questions to be answered.

If the burden was upon the plaintiffs to prove a loss from a cause and to an amount that would warrant a recovery, under the terms and provisions of the policy (a question which will be hereinafter dis-

cussed), then the amount proven must necessarily be what remains after all proper deductions have been made; and hence it was proper, on cross-examination, to permit the defendant to show that the proper deductions were not being shown by the testimony of the witness in chief. If the existence of the bottomry bonds and liens on the vessels were at all material, the court did not err in allowing all the facts to be brought out with reference thereto, although the witness had not directly testified to some of the points in his examination in chief. In such cases the matter of the extent of the cross-examination is largely within the discretion of the court.

With reference to the sixth assignment, it will be seen that the question which was objected to made the value of the vessel as repaired the standard of the costs of repairs, which is not the proper standard. In any event, it is clearly apparent that in the admission or refusal of testimony the court committed no error that would justify a reversal of these cases.

The contention of the plaintiffs, as tersely stated in their brief, involves five points, as follows: (1) There was an actual loss proven, and abandonment was unnecessary; (2) in any event, a constructive total loss was proven; (3) the insured could and did abandon; (4) there was an acceptance of the abandonment; (5) plaintiffs are, under any circumstances, entitled to recover as for a partial loss, and the cases should have been submitted to the jury.

A loss may be total or partial. A total loss may be actual or constructive. There is an actual total loss when the subject-matter of the insurance is wholly destroyed or lost to the insured, or where there remains nothing of value to be abandoned to the insurer. There is a constructive total loss where the insured has the right to abandon.

In the present case the testimony shows that the ship was not destroyed in specie; that after arriving at her port of distress she steamed 200 miles, at an average rate of 10 knots an hour, from Hilo to Honolulu. Generally it may be said that if a ship can be taken to a port and repaired it has not ceased to be a ship; that she is not utterly lost merely because it may cost more than she is worth to repair her. But there are numerous cases which hold that the mere fact that an insured vessel exists in specie does not necessarily prevent the insured from claiming a total loss without abandonment. *Insurance Co. v. Copelin*, 9 Wall. 461, 19 L. Ed. 739; *Northwestern Transp. Co. v. Continental Ins. Co.* (C. C.) 24 Fed. 171, 175, and authorities there cited. Every case depends upon its own particular facts, and upon the terms and provisions of the particular policy of the insurance in question.

Plaintiffs claim that there was an actual total loss shown by the evidence that the ship was not worth the cost of the repairs, and in support of this claim make the following quotation from the instructions given by Judge Curtis to the jury in *Bullard v. Insurance Co.*, 1 Curt. 148, Fed. Cas. No. 2,122:

"An abandonment is necessary only in case of a constructive total loss. If the loss be actually total, the insured may recover for it without an abandonment. It has been much discussed what constitutes a total loss

when the vessel remains in specie, and still retains the form of a vessel, in a place of safety. I shall not trouble you with the different views which have been taken of this question, but I will state the rules which I deem proper for your guidance. It is manifest that the form of a vessel may remain and be in a place of safety, and yet, for all useful purposes, the vessel may have ceased to exist. If she be absolutely incapable of repair, so as to be fitted to encounter the seas, then she has ceased to exist as a vessel, though great part of her materials may remain, and they may still be in the form of a vessel. So, though capable of being repaired and restored to the condition of a sea-going vessel, yet, if this can only be done at an expense exceeding the value of the vessel when repaired, it is an expense which no one is bound to incur, and therefore the case is the same as if absolutely irreparable; there being no practical difference, for this purpose, between what cannot be done at all and what no prudent person would undertake to do. And, therefore, if you should find, from the evidence in the case, that the injuries suffered by this brig from perils of the sea were so great that they could not be repaired so as to make her a seaworthy vessel, except at an expense exceeding her value when repaired, then this was a case of actual total loss, and no abandonment was necessary."

Here plaintiffs stop. Let us quote further:

"And here you will perceive it is necessary to have some standard to which to refer in fixing the value of the vessel when repaired. The parties have agreed in the policy on the value of the vessel. They have fixed it at \$3,000. Is this sum to be taken as her value when repaired, or are you to inquire into what would have been her actual value at Key West, in case she had been repaired? This is a question of no small difficulty, owing to the particular terms of this policy. The general rule, as settled by the supreme court of the United States, would require you to ascertain what the value of the brig would have been if repaired, and the agreed valuation, so far from being conclusive, would not usually afford any considerable aid in arriving at this result. But I find great difficulty in holding that rule applicable to this policy, which contains a clause, 'That the insured shall not have the right to abandon the vessel for the amount of damage merely, unless the amount which the insurers would be liable to pay, under an adjustment as of a partial loss, shall exceed half the amount insured;' and, further, 'In the adjustment of claims for repairs in the vessel, whether in the nature of a partial loss or general average, there shall first be a deduction of one-third, new for old, from the cost of labor and materials required in making the repairs.'"

It will thus be seen that the judge instructed the jury as to the distinctions which existed in different kinds of policies. The entire charge of the court clearly shows that the fact that when the vessel was repaired it would not be worth the cost of the repairs did not prove a total loss within the terms of the policy. The jury found a verdict for a partial loss only. Now, in that case the cost of repair to the brig was ascertained and testified to; hence the case did not, as here, rest solely upon the proposition that when repaired the brig would not be worth the cost of repairs. The case was therefore properly submitted to the jury.

It is important that in the discussion of the principles invoked we should, as far as possible, confine ourselves to the particular facts of the case in hand, and not depart therefrom, except, perhaps, for the purpose of illustrating the different conditions which create the distinctions existing in the various cases upon the same general subject. Parties must be governed by the terms of the contract which they have entered into, and are not bound by the rules which apply only to other and different kinds of contracts.

It seems to us unnecessary to review the cases of Insurance Co. v.

Southgate, 5 Pet. 604, 619, 8 L. Ed. 243, *Bradlie v. Insurance Co.*, 12 Pet. 378, 9 L. Ed. 1123, and the many other authorities cited, which plaintiffs claim establish the principle that if the vessel cannot be repaired without an expenditure of money to an amount exceeding one-half its value at the place of accident, after such repairs, then such damage constitutes a constructive total loss, and that the valuation in the policy is not an ingredient to be considered. The rule therein stated was recognized by Judge Curtis in *Bullard v. Insurance Co.*, supra, and announced by Judge Story in *Peele v. Insurance Co.*, 3 Mason, 27, Fed. Cas. No. 10,905. For comments on this case, see 2 Phil. Ins. 264, note 5.

In *Hughes*, Adm. § 38, the author, after stating the American rule as to the right of abandonment, and citing *Bradlie v. Insurance Co.*, supra, and other authorities, said:

"In consequence of these decisions, it has become common to provide in the policy itself that the right of abandonment shall not exist unless the cost of repairs exceeds one-half the agreed valuation."

In 2 Phil. Ins. § 1539, the author says:

"In the jurisprudence of the United States it is assumed in many cases that the rule of constructive total loss by damage over fifty per cent., where there is no provision to the contrary in the policy, refers to the value of the ship for sale at the time of the loss; in others, the rule is applied to the value in the policy."

And at section 1544 it is said that:

"The policies of some companies provide expressly for the deduction of a third for new in an adjustment as for a constructive total loss by damage to the ship, and also that such a loss must exceed one-half of the value at which the vessel is insured."

Conceding that the points made in this case are in some respects complicated, we are, nevertheless, of opinion that a reference to certain controlling principles, which are deemed applicable thereto, will be sufficient to dispose of the case without entering into a minute examination or review of the numerous authorities which range within the general principles discussed by counsel.

In order to entitle the plaintiffs to recover it is essential for them, by competent proof, to show a loss which comes within the terms of their policy of insurance. They must bring their case within the provisions of the contract for insurance. They are bound by the lawful agreements and stipulations therein contained, and must satisfactorily prove a loss. The burden is, of course, upon them to establish their right to recover. This general principle is supported by abundant authority. *Marcardier v. Insurance Co.*, 8 Cranch, 39, 48, 3 L. Ed. 481; *Heebner v. Insurance Co.*, 10 Gray, 131, 143, 69 Am. Dec. 308; *Paddock v. Insurance Co.*, 104 Mass. 521, 534; *Cory v. Insurance Co.*, 107 Mass. 140, 147, 9 Am. Rep. 14; *Tanner v. Bennett, Ryan & M.* 182.

In *Paddock v. Insurance Co.*, supra, the court said:

"The defendants, by the terms of their policies, not being liable for a partial loss unless it amounted to five per cent., or the ship was stranded, the plaintiff has the burden of proving a loss from a cause and to an amount for which the defendants are liable. * * * So, in the present cases, if

the plaintiffs seek to recover for a partial loss, either upon the ground that it was occasioned by stranding, or that it amounted to five per cent., they must prove the fact necessary to charge the underwriters. The affirmative of the proposition rests with the plaintiffs; the means of proof, to say the least, are as much within their knowledge and reach as within those of the defendants; and the difficulty of proving the amount of loss from any one cause is no greater than that of furnishing evidence which would enable the assessor to distinguish between injury to the vessel by perils of the sea and defective condition attributable to wear and tear and other ordinary causes, which, when these cases were last before the court, the plaintiffs were held bound to produce. The plaintiffs have failed to sustain the burden, thus resting upon them, of proving the amount of the partial loss by each peril."

In *Cory v. Insurance Co.*, supra, the court said:

"The policy further provides that the insurers shall not be liable for any partial loss, unless it amounts to five per cent., exclusive of charges and expenses incurred in ascertaining and proving the same; and it is well settled that the burden of proving a loss from a cause and to an amount for which the insurers are liable is upon the assured."

In *Marcardier v. Insurance Co.*, supra, the court said:

"In the present case the facts alleged by the plaintiff do not show a depreciation of a moiety in value excluding the memorandum articles. There is no evidence of the quantum of depreciation of any part of the cargo. The forced sales at Antigua could not, under the circumstances, constitute a medium by which to ascertain it. Admitting, therefore, the rule to be correct that the party had a right to abandon where the depreciation exceeds a moiety of the value, the plaintiff has not brought himself within that rule as applied to a cargo of a mixed character like the present. The court below were right, therefore, in deciding that there was no total loss proved by the perils of the sea."

We are of opinion that these authorities sustain the proposition that the evidence in this case, which consists of mere proof that the cost of repair would exceed the value of the ship when repaired, does not, under the provisions of the policy, prove either an actual total loss or a constructive total loss, and does not prove a partial loss.

There is no rule or presumption of law which makes the seaworthiness of the vessel at the commencement of the voyage prima facie evidence that the subsequent repairs made during the voyage arose solely from some extraordinary peril. The underwriters are never liable for losses occasioned by the mere wear and tear of the ship during a voyage. Mr. Justice Story, in *Donnell v. Insurance Co.*, 2 Sumn. 366, Fed. Cas. No. 3,987, upon this question among other things said:

"In every case in which the assured seeks to recover for such repairs against the underwriters he must show, not only that they were proper and necessary, but that they became so from the extraordinary perils of the voyage, within the policy. The loss is like every other loss within the policy. The onus probandi is on the assured to establish it by competent and satisfactory proofs, before he is entitled to recover it."

In 2 Phil. Ins. § 2141, the author said:

"The seaworthiness of the ship at the beginning of the voyage is not a ground of presumption that all the repairs that became necessary within the period of the risk, or a passage, were rendered necessary by extraordinary perils; the burden of proof is still on the assured otherwise to prove the damage to have been the effect of the extraordinary operation of the perils insured against."

The policy in the present case provides "that the insured shall not have the right to abandon the vessel, unless the amount which this company would be liable to pay under an adjustment, as a partial loss, * * * shall exceed half the amount hereby insured."

The contention of the plaintiffs is that (less certain stipulated deductions) a total damage to the vessel exceeding \$7,500 in the one case and \$2,500 in the other would render the insurance company liable to pay an excess of "one-half the amount hereby insured." In their brief counsel say: "We do not have to prove any greater loss than \$7,500 net as against the Western Assurance Company, and \$2,500 net as against the Thames & Mersey Company. Proof of these amounts gives us the same right to abandon as proof of loss amounting to \$75,000."

The contention of the defendant upon this point is that, in order to determine what the company "would be liable to pay under an adjustment as for a partial loss," the total damage to the vessel (less the deductions) must be ascertained, and compared with the valuation as stated in the policy; that the company would be liable to pay such proportion of "the amount insured" as the total damage thus ascertained bears to that valuation, because, in order to create the liability to pay one-half of the amount insured, the total damage must equal one-half of the insured value.

The text-books say:

"It is an elementary principle of insurance law, which pervades the whole system, cannot be enforced too early, nor borne in mind too attentively, that the underwriter pays no loss except with reference to the sum on which he is paid premiums; the whole sum, if the loss be total; same aliquot part of the sum, if the loss be partial." 1 Arnold (2d Ed.) *7, *8.

"An insurer must pay the same proportion of the whole loss that the sum insured is of the whole amount of the insurable interest." 2 Phil. Ins. § 1435.

In *Murray v. Insurance Co.* (Sup.) 25 N. Y. Supp. 414, 416, the court held that in determining the proportion which the cost of repairing a vessel must bear to its value, so as to justify its abandonment to the insurers as a constructive total loss, its value as stated in the policy controls.

But it is unnecessary to decide in the present case whether the amount of the insurance of \$15,000 in the one case, or \$5,000 in the other, or \$75,000, the value of the ship mentioned in the policy, constitute the basis of the computation, because no evidence appears in the record to give any basis whatever for the determination of the percentage of damage. The only evidence in this regard is confined solely to the proposition, heretofore stated, that the vessel when repaired would not be worth the cost of repairs, which is, as we have heretofore attempted to show, wholly insufficient. There must be some testimony upon which a jury could act in fixing the amount of damages. There being none, the court did not err in directing the jury to find a verdict for defendants.

It is next claimed by the plaintiffs that the defendant accepted the abandonment. The record shows that between November 23, 1898, and December 1, 1898, plaintiffs furnished defendant with notice of abandonment and proof of interest and loss, to which notice of aban-

donment defendant on or about December 1, 1898, responded in writing, declining to accept abandonment. It was admitted upon the trial that one Capt. Turner, early in December, came to Hilo, as the representative of the Western Assurance Company, to represent the interest of the insurers "under the sue and labor clauses, to do the best he could for all concerned." Capt. Milnor, of the steamship company, testified, in answer to questions, as follows:

"Q. I understood you to say after Mr. Turner arrived you co-operated with him in all matters pertaining to the interests of the vessel and all parties interested with her? A. I did, sir. Q. Did you so continue until you left the ship? A. Yes, sir. * * * Q. I believe you said you executed the bottomry bond at Hilo? A. Yes, sir. Q. At whose request did you execute that? * * * A. I executed it at the request of Capt. Turner. * * * Q. What did he say about the ship, if anything? A. Well, he thought that the ship was in pretty bad condition, but that she could be repaired in Honolulu. Q. What was said by you in answer? A. * * * I stated I doubted if she could be repaired at Honolulu, and he told me that he had consulted with Mr. Lisle, I think it was, who owned marine railway there, and that Mr. Lisle had stated to him that the vessel could be hauled out on those ways and repaired. I stated that I did not think the ways were heavy enough, and he thought that the ship ought to go to Honolulu. Q. And what did he do in connection with taking her, if anything, to Honolulu? * * * Did he say anything to you at that time or give you any directions or instructions? A. He said this ship ought to go to Honolulu. At the time he served the paper he did not give me any instructions. Q. Did he give you any instructions after that? A. Well, there was a conference in the office of the consular agent at Hilo, and there was present at that conference Mr. Boyd, the vice consular agent from Honolulu, and Mr. Ferno, the consular agent, Mr. Jacobson, Capt. Turner, and myself. * * * Sheriff Andrews bustled into the room with a number of lien claims, and was in the act of serving papers on me in some libel suits which were about to be brought. I fell back on my rights as an American citizen, standing then on American territory, and the sheriff had invaded that territory; but Capt. Turner said: 'Mr. Sheriff, if you will suspend the service of those papers for a day I will personally see that these matters are settled.' The sheriff, after some consultation, retired. Capt. Turner made a statement, if I remember correctly, of the situation to the vice-consul, claiming that he thought the ship abundantly able to go to Honolulu, and it would be for the best interests of all concerned that she should go there. I refused to assume the responsibility of going or attempting to take the ship to Honolulu, fearing that she would go down on the voyage, and that the responsibility would be upon my shoulders. After considerable argument it was— Capt. Turner stated that the status of the ship should be—as respects the insurance—the same at Honolulu as it then was at Hilo. He further stated his firm belief that she was able to make the voyage, and insisted upon going. Consul Boyd then insisted on my taking it upon Capt. Turner's assuming the responsibility, which he did. Q. Who financed the boat out, if you know? A. Capt. Turner saw a Mr. Mason, a merchant at Hilo. I don't know how that transpired. I was not present at the conference between them; but about two thousand dollars was required to finance the ship out of Hilo, and Mr. Mason put up the sum of money and took the bottomry bond. Q. At whose request? A. Capt. Turner made the negotiations with him; I did not. Q. Were there any temporary repairs made to the machinery? A. Yes, sir. * * * Q. At whose direction were those repairs made? A. I can't swear to that positively. Q. Were they made at your directions? A. Everything about the ship was made by my direction, in this way. I ordered the men to make such partial repairs about the machinery of that ship as would enable them to keep her afloat under all contingencies. It was my duty to save the property, and I was acting along that line."

It will be seen from the testimony that Capt. Turner and Capt. Milnor worked together for the benefit of all concerned. There are no facts in the case which show that Capt. Turner performed any act beyond the powers conferred upon him by the "sue and labor" clause. When the ship arrived at Honolulu she was libeled by the seamen for their wages, for which the ship was liable. This deprived the defendants of the power to possess themselves of the property, and made an acceptance of the abandonment impossible.

Washburn & Moen Mfg. Co. v. Reliance Marine Ins. Co., 179 U. S. 1, 18, 21 Sup. Ct. 1, 45 L. Ed. 49, was the case of an insurance on the cargo of a vessel which put into port at Key West, from which point the goods were forwarded to their destination, where they were tendered to the plaintiff, who refused to accept them, having abandoned them to the insurance company for a total loss. There were no facilities for handling and no market for the goods at Key West, but there were at the port of destination to which they were brought by the insurers. The goods were sold in an action for freight, demurrage, and expenses on the part of the vessel that had brought them forward from the port of distress. There was some controversy in the testimony as to who forwarded the goods,—whether it was by the direction of Capt. Hall, who was acting for the insurers, or by the defendant. The record shows that the agent for the board of underwriters testified that he instructed the agent at Key West to see that a vessel was secured and the cargo properly shipped to Velasco according to the original bill of lading; that Hall authorized the Cactus to be chartered, and that he always insisted that Hall should forward the cargo, while Hall stated that he had received a request from defendant's agent to so forward it. The supreme court in the case, among other things, said:

"The circuit court correctly ruled that under the terms of the policy plaintiff could not recover for a constructive total loss of the goods insured, and, inasmuch as a large part of the goods reached Velasco in specie, a substantial part of them being wholly uninjured, was right in declining to permit the jury to pass on the question of actual total loss. There is nothing taking the case out of the general rule. The forced sale certainly does not affect it. * * * If there had been a constructive total loss and a sufficient abandonment prior to the sale, defendant was then liable. As there was not, and no right to abandon or acceptance of abandonment, the goods were at plaintiff's risk, and defendant was not responsible for any loss plaintiff sustained by the sale. But although, as we have seen, plaintiff had no right to abandon, and although defendant specifically refused to accept an abandonment, it is contended that defendant transshipped the wire, and that such transshipment amounted to an acceptance of abandonment. The circuit court of appeals was of opinion that the forwarding from Key West to Velasco was done under the authority and with the approval of the captain of the Benjamin Hale. As the cargo was in a condition for transshipment, and there was opportunity to effect it, defendant rightfully insisted that it was the duty of the master to forward it to the destined port. Yet even if the underwriters chartered the Cactus, and forwarded the cargo, we agree with both courts that neither that nor any other act disclosed by the evidence would have authorized the jury to find that defendant had accepted the attempted cession of the cargo. The sue and labor clause expressly provided that acts of the insurer in recovering, saving, and preserving the property insured, in case of disaster, were not to be considered an acceptance of abandonment. Whether regarded as embodying a common-law principle, or

as new in itself, the clause must receive a liberal application, for the public interest requires both insured and insurer to labor for the preservation of the property. And to that end provision is made that this may be done without prejudice. * * * If, then, it was the insurer that carried the property to be preserved and carried to Velasco, where it was offered to the consignees, such labor and care, rendered in good faith, did not operate as an acceptance of abandonment, and especially as there was no right to abandon and a distinct refusal to accept. Acts of the insurer are sometimes construed as an acceptance, when the intention to accept is fairly deducible from particular conduct, in the absence of explicit refusal. Silence may give rise to ambiguity solvable by acts performed. Here, however, defendant refused to accept, and there was no ambiguity in its attitude; and what was done, if done by it, was no more than it had the right to do without incurring a liability expressly disavowed. There was nothing to be left to the jury on this branch of the case."

Under all the circumstances of this case there was not, in our opinion, anything to submit to the jury on the question of acceptance of abandonment.

The only point presented by plaintiffs in case No. 749 not covered by the views already expressed is the fact that the defendant demanded and accepted payment of one of the premium notes after the notice of abandonment and notice of loss, and that a further demand was subsequently made by the defendant for payment of the remaining premium notes. It is true that the receipt of a premium after a forfeiture occurs might waive the forfeiture; but in this case the question as to the right of plaintiffs to recover depended alone upon proofs of loss, and as no loss, within the terms of the policy, was proven, they cannot recover. The receipt of the premium did not relieve the plaintiffs from the necessity of proving such a loss.

The record shows that:

"It was further stipulated to be the fact that the defendant made full and proper tender on March 2, 1901, of the full amount of the premium paid to the said Thames & Mersey Marine Insurance Company, for or on account of insurance effected by said plaintiffs, or either of them, with said Thames & Mersey Marine Insurance Company on the steamship City of Columbia, under policy of insurance now in evidence, and that they made full and proper tender and offered to return the unpaid premium notes on account of said premium."

We are unable to see how the facts stated could in any manner affect the results reached by the court below.

The judgments in both cases are affirmed, with costs.

BOARD OF COM'RS OF FRANKLIN COUNTY, OHIO, v. GARDINER
SAV. INST.

(Circuit Court of Appeals, Sixth Circuit. December 2, 1902.)

No. 1,106.

1. MUNICIPAL BONDS—COUNTY BONDS FOR ROAD IMPROVEMENT—OHIO STATUTE. Act Ohio March 26, 1890, as amended by Act Ohio March 7, 1892 (89 Ohio Laws, p. 66), authorizes county commissioners in counties in which there are situated cities of the first grade of the second class to improve roads or streets in certain cases, on petition, when they deem the same a judicious improvement, and to assess the cost thereof on abut-

ting property. It further authorizes them, "to provide for the payment of the costs and expenses of said improvement to be assessed upon the abutting property," to issue bonds and negotiate the same at not less than par, "as other bonds of said county are negotiated." It requires them to levy the assessments which shall be payable in installments to meet the bonds, and shall be a lien on the property, and to appropriate the same, when collected, solely to the payment of such bonds, and authorizes them, in case any bond or interest shall become due, and no money is in hand to pay the same, to make a temporary loan for the purpose, in which case the lien of the assessments shall continue for the benefit of the county. *Held*, that in the absence of any provision, either in the act, or in bonds issued thereunder, that such bonds should be payable only from the assessments when collected, they constituted obligations of the county, and that on default in their payment a holder was entitled to a judgment at law thereon against the county, without regard to the question of the means by which such judgment could be enforced.

2. FEDERAL COURTS—FOLLOWING STATE DECISIONS—LAW OF CONTRACT.

In a suit in a federal court on municipal bonds, the question of the validity of the legislative act under which they were issued is to be determined by the law of the state as judicially declared by its highest court at the time the bonds were issued; and where, under such law, the act was valid, the rights of a holder of the bonds cannot be affected by the fact that before the date of his purchase the court had overruled its prior decisions and declared it invalid.

3. MUNICIPAL BONDS—VALIDITY—PARTIAL INVALIDITY OF STATUTE.

The unconstitutionality of a method provided by law for making special assessments to pay bonds issued by a county to pay for road improvements, if conceded, does not affect the validity of the bonds as obligations of the county, or the right of a holder to recover judgment thereon.

In Error to the Circuit Court of the United States for the Southern District of Ohio.

This action was brought to recover on certain bonds. The petition was drawn in the usual form of the Ohio Code, upon unconditional promises to pay, and contains a number of causes of action upon the bonds and coupons. It is alleged, among other things, that the bonds were issues on the 1st of January, 1894, by the board of commissioners of Franklin county, Ohio, and duly executed and sold by the defendant. The bonds were in the following form:

"State of Ohio.

"No. _____

"Franklin County.

"North Fourth Street Improvement and Extension Bond.

"Know all men by these presents, that the county of Franklin, state of Ohio, is indebted to the bearer in the sum of one thousand dollars, lawful money of the United States of America, which sum of one thousand dollars the said county of Franklin promises to pay to the said bearer, at the office of the treasurer of said county, on the first day of January, A. D. _____, but redeemable and payable at any time on or before, at the option of said county, with interest at the rate of six per cent. per annum, payable semiannually on the first days of January and July of each year, upon the presentation and delivery of the proper coupon hereto annexed, signed by the commissioner of Franklin county, and countersigned by the county auditor at the said county treasurer's office, Columbus, Ohio. This bond is issued under and by virtue of section seven of an act of the general assembly of the state of Ohio, passed March 26th, A. D. 1890, entitled 'An act to authorize county commissioners in counties in which there are situated cities of the

¶ 2. State laws as rules of decision in federal courts, see notes to *Griffin v. Wheel Co.*, 9 C. C. A. 548; *Wilson v. Perrin*, 11 C. C. A. 71; *Hill v. Hite*, 29 C. C. A. 553.

first grade of the second class, to improve roads extending from such cities and other roads and streets in certain cases;' also by virtue of a resolution heretofore passed by the board of county commissioners of Franklin county, Ohio, on the 6th day of August, A. D. 1892; and it is to be paid for by an assessment upon the property abutting on North Fourth street (in Clinton township), from Chittenden avenue to the north line of Indianola Summit addition, for the purpose of improving and extending the same. In testimony whereof, we, the undersigned officers of Franklin county, Ohio, being duly authorized to execute this obligation on its behalf, have hereunto set our signatures, and caused the seal of said county to be hereunto affixed, this first day of January, A. D. 1894.

T. D. Cassidy,
"S. B. Biggert,
"J. B. McDonald,

"Commissioners of Franklin County, Ohio.

"Henry J. Caren, County Auditor."

The prayer of the petition is for a judgment at law upon the bonds for the aggregate sum of \$5,630, with interest and costs. A demurrer was filed to the petition upon the following grounds:

"(1) The act of the general assembly passed March 26, 1890, as amended March 7, 1892, under and by virtue of which the bonds and coupons described in the petition were issued, contravenes article 2, § 26, of the constitution of Ohio, and therefore said bonds and coupons thereto attached are invalid.

"(2) Said act of the general assembly passed March 26, 1890, as amended March 7, 1892, under and by virtue of which the bonds and coupons described in the petition were issued, contravenes the fourteenth amendment of the constitution of the United States, and therefore said bonds and the coupons thereto attached are invalid.

"(3) On all of said bonds sued upon the petition, and to each of which the coupons set out in said petition were attached, there is contained the following condition and recital: 'This bond is issued under and by virtue of section seven of an act of the general assembly of the state of Ohio passed March 26, A. D. 1890, entitled "An act to authorize county commissioners in counties in which there are situated cities of the first grade of the second class, to improve roads extending from such cities and other roads and streets in certain cases;" also by virtue of a resolution heretofore passed by the board of county commissioners of Franklin county, Ohio, on the 6th day of August, A. D. 1892; and is to be paid for by an assessment upon the property abutting on North Fourth street (in Clinton township), from Chittenden avenue to the north line of Indianola Summit addition, for the purpose of improving and extending same.'

Upon hearing, this demurrer was overruled. Afterwards the board of commissioners filed an answer in which they admitted that the bonds were issued under the authority of a certain act of the general assembly of Ohio, entitled "An act to authorize the county commissioners in counties in which there are situated cities of the first grade of the second class to improve roads extending from said cities and other roads and streets in certain cases" (87 Ohio Laws, p. 113); that the copies of the bonds as set out were true copies thereof; and that the bonds and coupons became due, and the plaintiff was the owner thereof, at the time the petition was filed. By way of special defenses, the commissioners set up further:

"Second Defense. That the total cost of the North Fourth street improvement, from Chittenden avenue to the north line of Indianola Summit addition, in Clinton township, to pay for which the bonds and interest coupons set out in the petition were sold, including the interest on the bonds to the next interest day when the assessments could be collected to pay for the same, amounted to \$92,050.85, and that on the 3d day of December, 1895, the board of commissioners of Franklin county, Ohio, levied an assessment of eight dollars eighty-seven cents and eight and twelve-hundredths mills per front foot on all the property fronting and abutting on said improvement, and amounting in all to eighty-three thousand two hundred and seventy-six dollars and seventy cents (\$83,276.70). That said assessment so levied was duly placed upon the tax duplicate of Franklin county, Ohio, against the property abutting

and fronting on said improvement on North Fourth street from Chittenden avenue to the north line of Indianola Summit addition in Clinton township. That the county treasurer of Franklin county, Ohio, has proceeded to and has collected said assessments as they became due, except the assessments levied against the property of the following named owners: Sallie H. Sarguy, Sarah E. and D. R. Summy, the Summit Land Company, Wm. C. Frech, W. E. Smith, Phoebe Thompson, Wm. E. Peters, Henry Boska, A. C. Hartman, Estella M. Berry, Rebecca Ellis, Asa B. Dennison, John W. Thompson, E. W. Dow, Mulby Bros., Cath. C. Cottingham, Eliza Wildermuth, W. Guy Jones, Ira H. Miller, Hanna Goodman, Lynas B. Kauffman, Oscar E. Miles, Harry N. Hills, Fred N. Abbott, Gilbert G. Raynor, Oliva A. Spear, David E. Shrider, Henry Morton, Isaac E. Chaplear et al., Albert K. Neer, Mary A. Meyers, The A. Simons, Geo. W. Clark, Kate Spellman, and A. E. Dennison,—which said property owners have filed their petition in the court of common pleas of Franklin county, Ohio, and upon said petitions temporary restraining orders have been issued against the treasurer of Franklin county, Ohio, restraining him temporarily from collecting said assessments levied against said property or any of them; and said restraining orders are still in full force and effect, and have not been dissolved, and for that reason the assessments so levied upon the property of the persons hereinbefore mentioned have not been collected, and the same remain unpaid. That all moneys received from the assessments so levied upon the property abutting on North Fourth Street, in Clinton township, from Chittenden avenue to the north line of Indianola Summit addition, to pay for the improvement thereof, have been appropriated by the proper officers of Franklin county, Ohio, solely to the payment of the interest and redemption of said bonds so issued for said improvement. And said fund is now entirely exhausted, and there remains in the hands of the treasurer of said Franklin county, Ohio, no money which has been collected from said assessments upon the property abutting upon North Fourth street from Chittenden avenue to the north line of Indianola Summit addition, in Clinton township. In addition to the moneys so collected from said assessments, the sum of \$7,100 has been applied to the payment of the bonds and interest coupons which were issued to pay for the cost of said North Fourth street improvement from Chittenden avenue to the north line of Indianola Summit addition in Clinton township. By reason of the restraining order so issued as aforesaid, the treasurer of Franklin county, Ohio, has been unable to collect said assessments as they became due. Said treasurer of Franklin county, Ohio, the auditor of Franklin county, Ohio, and the board of county commissioners of Franklin county, Ohio, have done each and every act which has been authorized by the statutes by the state of Ohio to levy and collect assessments provided for by the act of the general assembly which authorized the issuing of the bonds and interest coupons sued upon in the petition, and have failed to collect said assessments only by reason of the temporary restraining order restraining the treasurer of Franklin county, Ohio, from collecting the assessments hereinbefore set out. The board of county commissioners of Franklin county, Ohio, refused to pay the bonds and interest coupons set out in the petition for the reason that the constitution of the state of Ohio (article 10, § 5) provided, 'No money shall be drawn from any county or township treasury except by authority of law.' And the only authority which the defendant has for paying the bonds and interest coupons set out in the petition is the act of general assembly of the state of Ohio passed March 16, 1890, which authorized said board to pay said bonds and interest only from such assessments as shall be collected from the property abutting upon the improvement to pay for which said bonds are issued. No tax has been levied by the defendant, the board of county commissioners of Franklin county, Ohio, to pay the bonds and interest coupons set out in the petition, except said assessment hereinbefore set out, to wit, the assessments upon the property abutting upon North Fourth street, in Clinton township, from Chittenden avenue to the north line of Indianola Summit addition, as provided by sections 8 and 9 of said act of the general assembly of the state of Ohio, passed March 26, 1890, for the reason that the constitution of Ohio (article 12, § 5) provides that no tax shall be levied except in pursuance of law, and every law imposing a tax shall state distinctly the object of the same, to which only it shall be applied."

And for further defense:

"Third Defense. For a further and third defense to each and all of the alleged causes of action set out in the petition herein, the defendant avers that the said act of the general assembly of the state of Ohio passed March 26, 1890, as amended March 7, 1892, is and was in contravention of article 2, § 26, of the constitution of the state of Ohio, and is therefore null and void. That previous to the 28th day of April, 1896, legislative acts similar to the said act of March 26, 1890, were upheld and declared valid by the various courts of the state of Ohio. That on said 28th day of April, 1896, the supreme court of Ohio, the same being the highest judicial tribunal therein, in the case of Hixson v. Burson, 54 Ohio St. 470, 43 N. E. 1000, decided and adjudged that an act of the legislature of Ohio providing for the repairs and improvements of certain public highways, and which said act was similar to the said act of March 26, 1890, in that its subject-matter was general, while its application and effect were local, was in conflict with section 26, art. 2, of the constitution of Ohio, and was therefore void. That ever since the date of the decision of the said case of Hixson v. Burson by said supreme court of Ohio, to wit, since April 28, 1896, said court has declared each enactment of the legislature of Ohio authorizing the repair or improvement of the public highway, and which by its operation could only affect one county in the state, to be unconstitutional and void, for the reason that all such legislation was in violation of section 26 of article 2 of the constitution of Ohio. That at the time the said act of March 26, 1890, and the said amendment thereto, was passed, the only county in the state of Ohio which contained a city of the first grade of the second class was said Franklin county. All of the facts stated in this defense were well known to the plaintiff at the time it purchased the bonds and coupons, and each thereof, set out in the petition. The defendant denies that the plaintiff purchased the bonds and coupons set out in the petition, or any or either thereof, on the —— day of ——, 1894, but alleges that neither thereof was purchased by the plaintiff, nor did it become the owner or holder thereof, until long after the said case of Hixson v. Burson was decided by the supreme court of Ohio, to wit, after the 28th day of April, 1896. The exact date when said purchase was made the defendant is not now able to state, for want of definite knowledge. Wherefore the defendant avers that the said supreme court of Ohio had, previous to the time when the plaintiff purchased and became the owner of any of the bonds or coupons set out in the petition, held, decided, and adjudged that all legislation in Ohio similar to the said act of March 26, 1890, was unconstitutional and void."

To this answer a demurrer was filed by the plaintiff, which was sustained by the court. No further pleadings being filed, a judgment was rendered for the plaintiff upon the bonds and coupons. A copy of the act under which the bonds were issued is here given, as follows:

"An act to authorize county commissioners in counties in which there are situated cities of the first grade of the second class to improve roads extending from such cities and other roads and streets in certain cases.

"Section 1. Be it enacted by the general assembly of the state of Ohio, that in counties in which there are cities of the first grade of the second class, county commissioners shall have authority to cause any of the streets or avenues, or parts thereof of said cities which may have been paved with granite or other stone block, asphalt or other permanent material to the limit of said city, to be extended beyond the limits of said cities and improved by paving as aforesaid, or to cause any other road or street within said counties to be so improved upon the following conditions, to wit:

"Sec. 2. The property owners of lands fronting upon such road, street or streets being desirous of having said road, street or streets extended and so improved beyond the limits of said cities, or any other road, street or streets within such counties so improved, shall petition said commissioners to have said street or streets extended, widened and so improved, as called for in said petition; said petition shall state therein with what material said street shall be paved, provided with sidewalks, gutters and other passages for carrying off the water, and stating therein to what point on said road or

street said improvement is to be extended, or between what points on such other road or street such improvement is to be made. No petition for the improvement of any road or street under the provisions of this act shall be favorably considered by said commissioners unless it is signed by the property owners representing a majority of the feet frontage of the lands abutting upon said road or street, between the city limits mentioned therein, and the point designated in said petition where said improvement shall stop, or the points upon such other road or street where said improvements shall begin and end, and the distance between such points shall be mentioned by the number of feet upon the line of said road or street.

"Sec. 3. Whenever the commissioners of such county shall receive such petition, they shall appoint a time and place for the hearing of said application, not less than four weeks thereafter, publish a notice of such hearing in some newspaper of general circulation in the vicinity of the proposed improvement, for not less than two consecutive weeks, one each week, and cause service of said notice to be given to all owners of property fronting upon the proposed improvement, their agents or attorneys, at least two weeks before said hearing.

"Sec. 4. All owners of lots or lands bounding or abutting upon the proposed improvement claiming damages therefor, shall file a claim in writing with said county commissioners, setting forth the amount of damages claimed, together with a description of the property owned for which the claim is made, within one week after the expiration of the time required for [the] publication of said notice, and all such as shall fail or neglect to file their claim for damages aforesaid, within the time aforesaid, shall be deemed to have waived the same and be forever barred from filing any claim or recovering any damages therefor.

"Sec. 5. Upon the day appointed for said hearing, if no claim for damages or for appropriations have been filed, or if whatever claims have been filed are allowed by the commissioners as hereinafter authorized, the hearing may proceed, and if, upon such hearing, the county commissioners shall be satisfied that the owners of a clear majority of the feet front of land abutting upon said proposed improved roadway favor said improvement, and that the proposed improvements are judicious, it shall be their duty to declare said improvement authorized and established, and to declare the width of said road legalized and established, as of the dimensions and manner as prayed for in said petition, and to make a permanent record of their said action. When said action is taken by the county commissioners they shall immediately notify the county surveyor of their action; said commissioners shall have the authority to allow claims as presented or as may have been acted upon. They shall also have authority to sit as arbitrators, and hear all claims arising out of such proposed improvements. They may subpoena witnesses and hear testimony, and upon final hearing shall find and determine the amount, if any, fairly due the claimant, or that claimant is entitled to no damages, and their finding shall be conclusive.

"Sec. 6. It shall be the duty of the county surveyor, upon receiving such notice from the county commissioners, that such a road has been widened, or other improvements authorized, to survey such road, erect stakes or monuments in front of each piece of property, marking the outside lines of such road so widened or extended, and do whatever other work [may be] necessary for said improvement, as ordered by said commissioners. It shall be the duty of said commissioners to assess all claims allowed by them for the establishment and widening of said street or streets upon the property fronting on such road so improved by the foot front. All other expenses for said improvement, except building bridges and culverts, which shall be paid out of the county bridge fund, shall be paid for and assessed upon the property abutting upon said street, not, however, to a greater depth than two hundred and fifty feet, in accordance with the various provisions of law now enacted or hereinafter enacted applicable thereto, and not inconsistent with this act.

"Sec. 7. In order to provide for the payment of the costs and expenses of said improvement to be assessed upon the abutting property, the commissioners may, from time to time, as such improvement progresses, issue the

bonds for such road improvement, in such sums as will be required, in all to an amount not exceeding the contract price of the work and the other expenses attending the same, and interest as hereinafter provided for. Said bond shall be issued as other bonds for road improvement are issued, but they shall bear the name of the street for whose improvement they are issued, and shall state therein that they are to be paid by an assessment upon the property abutting on the said improvement; said bonds shall extend over a period of at least eight years, and for as much longer time as may be provided in the order of said commissioners directing said improvement; they shall bear interest at a rate not exceeding six per cent. per annum, payable semi-annually, on the first day of July and January, principal and interest payable at the office of the county treasurer.

"Sec. 8. The said bonds shall be negotiated at not less than par, as other bonds of said county are negotiated, and the proceeds shall be applied solely to pay for said improvement, and the proceeds thereof shall only be paid upon the certificate of the county surveyor and superintendent hereinafter provided for, that the work has been done according to the contract; when the whole work is done the amount of the bonds sold to pay for the same and the interest thereon to the next interest day, when the assessments can be collected as hereinafter provided to pay the same, shall be taken as the cost of the said improvement to be paid by the abutting property owners, and that amount shall be assessed equally by the foot front of property fronting or abutting on the said improvement.

"Sec. 9. Such assessment shall be placed upon the tax duplicate and shall be payable in equal installments to meet said bonds, provided for in the order of said commissioners, ordering said improvement, at the county treasurer's office, with interest at the rate provided for in said bonds, payable semi-annually, from the date to which such semi-annual interest was computed on the amount of said bonds or so much as remains unpaid from time to time, until all said bonds and interest are fully paid.

"Sec. 10. Such assessment, with interest accruing thereon, shall be a lien on the property abutting upon the street or roads improved from the time the contract is entered into for the making of said improvement, and shall remain a lien until fully paid, having precedence over all other liens, except taxes, and shall not be divested by any judicial sale unless the payment of the same is provided for, from the proceeds of such sale; such lien shall be limited to the depth of two hundred and fifty feet on the lands abutting on said improvement; no mistakes in the description of the property or the names of the owner or owners shall impair the said lien.

"Sec. 11. Any owner of property against whom an assessment shall have been made for such improvement shall have the right to pay the same, or any part yet remaining unpaid in full, with interest thereon, to the next semi-annual payment due on said assessment; such payment shall discharge the lien on the property. If any owner shall subdivide any abutting property after such lien attaches he may discharge the same upon any part thereof in like manner.

"Sec. 12. All moneys received from such assessments shall be appropriated by the proper authorities of the county solely to the payment of the interest and the redemption of the bonds issued for said improvement, or any part thereof. If any bond or interest shall be due and no money is in hand to pay the same, the commissioners shall be authorized to make a temporary loan to pay the same; but such lien shall continue in full force on the abutting property for the full assessments not paid and accruing interest for such temporary loan in behalf of said county.

"Sec. 13. When such order has been made by said commissioners for the improvement of any street under the provision of this act, they shall designate two or more owners of property abutting on said improvement who, with the county surveyor, shall constitute a board which, after the contract for the improvement has been made by the commissioners, may elect a superintendent who shall see that the said contract is performed according to the true intent, and all orders of the county surveyor in furtherance thereof are obeyed. When completed the said superintendent and surveyor shall certify to the same, and shall make a proper plat and assessment for said improve-

ment on the abutting property. The property owners of such board shall serve without compensation, but the superintendent shall be paid such compensation as shall be agreed upon by the board, and such payments shall be a part of the costs of said improvements thereof.

"Sec. 14. In any action to enforce or enjoin any assessment, the court shall disregard any irregularity or defect, whether in the proceedings of the said board or commissioners, or any officer of the county, or in the plans or estimates; and the acceptance of the work by the commissioners upon the certificate of the superintendent or county surveyor shall be presumptive evidence that the contract has been complied with, and the assessment exists, but if it be shown that there are any substantial defects of the improvement, or any fraud in the contract price of the work or material, the court may order such deduction therefor, from the cost of said improvement, and such deduction shall be ratably deducted from the assessment on all the property abutting on said improvement, and the court may make such order in regard to the costs, where such substantial defect or fraud is found, as to the court shall seem proper.

"Sec. 15. The term owner, in this act, shall be construed to include all corporations, private, public, state or municipal.

"Sec. 16. On the completion of the improvement of any road or street under the provisions of this act, the commissioners shall appoint a board of control for said roadway, to consist of three of the property owners of the lands abutting upon said improvement, who shall serve without compensation, and have charge of the repairs and condition of said improved road. Said board shall be appointed to serve two years, or until their successors are duly appointed and qualified. Said commissioner shall fill any vacancy that may occur in said board by an appointment for such unexpired term. Said board shall see that said improved roadway be kept clean and in good repair, and all expenses incurred by said board in such work shall be by them returned to the auditor of the county in a written report of said board, to wit: On the first Tuesday of January, of each year, together with an itemized statement of the expenses incurred by said board, which sum, if deemed correct and proper by said auditor, shall be by him assessed per foot front on all property abutting on said improvement; such assessment, until paid, shall be a lien, as other expenses of making said improved road.

"Sec. 17. In no case shall said commissioners take action for the improvement of any road under the provisions of this act, until after they shall have made a personal inspection and examination of the line of said proposed improvement, and are satisfied that with such improvement the foot frontage of the lands abutting thereon will be well worth double the estimated expenses of such improvement, which inspection, examination, and estimate, together with their present valuation per foot front of said lands, shall be by said commissioners made a matter of record, and no improvements shall be by them ordered, unless said record justifies it. The improvement of all streets under the provisions of this act shall be by said commissioners let to the lowest and best bidder, after two weeks' notice by said commissioners of said letting, published in some newspaper of general circulation in the vicinity of said proposed improvement. The said commissioners shall establish rules for letting of such contracts, which rules shall be printed and posted in the office of said commissioners.

"Sec. 18. This act shall take effect and be in force from and after its passage.

"Passed March 26, 1890."

87 Ohio Laws, pp. 113-118.

The following is a copy of the amendment to the above-recited act, and is found in 89 Ohio Laws, pp. 66, 67.

"An act to amend sections 1 and 5 of an act entitled 'An act to authorize county commissioners in counties in which there are situate cities of the first grade of the second class to improve roads extending from such cities, and other roads or streets in certain cases,' passed March 26, 1890.

"Section 1. Be it enacted by the general assembly of the state of Ohio, that sections one (1) and five (5) of an act entitled 'An act to authorize county

commissioners in counties in which there are situated cities of the first grade of the second class to improve roads extending from such cities, and other roads or streets in certain cases,' passed March 26, 1890, be amended so as to read as follows:

"Section 1. That in counties in which there are cities of the first grade of the second class, county commissioners shall have authority to cause any of the streets or avenues, or parts thereof of said cities which may have been paved with granite or other stone block, asphalt or other permanent material to the limit of said city, to be extended beyond the limits of said cities, and improved by paving as aforesaid, or by improving the same with such materials and in such manner as may be prayed for by the property owners in the petition as provided by section two of this act, or to cause any other road or street within said counties to be so improved upon the following conditions, to wit:

"Sec. 5. Upon the day appointed for said hearing, if no claims for damages or for appropriations have been filed, or if whatever claims have been filed are allowed by the commissioners as hereinafter authorized, the hearing may proceed, and if, upon such hearing, the county commissioners shall be satisfied that the owners of a clear majority of the feet front of land abutting upon said improved roadway favor said improvement, and that the proposed improvements are judicious, it shall be their duty to declare said improvement authorized and established, and to declare the width of said road legalized and established, as of the dimensions and manner as prayed for in said petition, and to make a permanent record of their said action. When said action is taken by the county commissioners they shall immediately notify the county surveyor of their action; said commissioners shall have authority to allow claims as presented or as may have been acted upon. They shall also have authority to sit as arbitrators, and hear all claims arising out of such proposed improvements. They may subpoena witnesses and hear testimony, and upon final hearing shall find and determine the amount, if any fairly due the claimant, or that claimant is entitled to no damages. From such finding and determination of said commissioners, any property owner may appeal to the court of common pleas of said counties upon his filing with said commissioners his written notice of such appeal within five days after such finding and determination, and upon his giving bond, to be fixed by said court, within twenty days after such finding and determination, to pay all costs to be made upon such appeal, in case he does not recover upon such appeal a greater amount than such finding and determination of said commissioners award him. The award of the jury upon such appeal, including the costs thereof in case such award exceeds that found and determined by said commissioners, otherwise said cost shall be paid by the person taking such appeal, shall by the clerk of said court be certified to said commissioners and by them assessed as provided by section six of this act. Provided, no appeal shall hinder or delay the making of said improvement.'

"Sec. 2. That said sections one (1) and five (5) as passed originally March 26, 1890, be and the same are hereby repealed.

"Sec. 3. This act shall take effect and be in force from and after its passage.

"Passed March 7, 1892."

A. T. Seymour, for plaintiff in error.

Wm. B. Sanders and W. H. Harris, for defendant in error.

Before LURTON, DAY, and SEVERENS, Circuit Judges.

DAY, Circuit Judge, after making the foregoing statement of facts, delivered the opinion of the court.

In this case counsel have elaborately argued questions as to the authority of the commissioners of Franklin county to levy a general tax for the payment of the bonds sued upon; it being insisted on behalf of the bondholders that, notwithstanding a method of assess-

ment upon the property abutting upon the road is set forth, which may provide a means of ultimate payment as between the county and the property owners, the bonds constitute a general indebtedness of the county, to be collected by general taxation. On the other hand, it is contended that as the bonds, on their face, stipulate that they shall be paid out of the assessments on the property, and, no authority being conferred in the act authorizing the improvement to incur a general liability of the county, the only obligation of the county is to use diligence to collect and to apply the assessments for the benefit of the bondholders. These contentions can be considered now only in so far as they bear upon the authority of the county commissioners to obligate the county, under the powers conferred in the act under consideration, by the issue of the bonds in suit. This case is not one asking the issue of a writ of mandamus either to levy a tax or require assessments as provided in the statute. The present case is a straight action at law, asking a money judgment on the bonds, and no more. It stands confessed by the demurrer, and the answer that the commissioners executed and sold the bonds and received the proceeds thereof. By way of defense, it is urged that the commissioners had no authority to issue the bonds of the county under the terms of this act in such wise as to make any obligation upon the county beyond the collection of the assessments. The commissioners are a quasi corporate body, having the authority to sue and be sued as such, and to enter into contracts and obligations within the scope of their duties duly conferred by law. Rev. St. Ohio, § 845; State v. Commissioners of Hancock Co., 11 Ohio St. 190. It is this quasi corporate body which by the terms of the act is authorized to construct the improvement. The law is entitled:

"To authorize county commissioners in counties in which there are situated cities of the first grade of the second class to improve roads extending from said cities and other roads and streets in certain cases."

While the making of the roadway is to be upon the petition of the abutting landowners, the road is only established when the commissioners deem the same to be a judicious improvement. The commissioners are charged with the duty of seeing to it that, with the proposed improvement, the foot frontage of the abutting lands shall be worth double the estimated expenses of such improvement. The commissioners are to let the contract for the work. These provisions indicate the general purpose to make a county improvement, to be contracted for by the representatives of the county. The improvement was to be paid for by the sale of bonds to raise money for that purpose, and we find it provided in section 7:

"In order to provide for the payment of the costs and expenses of said improvement to be assessed upon the abutting property, the commissioners may, from time to time, as such improvement progresses, issue the bonds for such improvement in such sums as will be required in all to an amount not exceeding the contract price of the work and the expenses attending the same and interest."

The following section (8) provides that the bonds shall be negotiated at not less than par, as other bonds of said county are negotiated, and the proceeds applied solely to pay for said improvement.

We find in section 7 authority to issue "the bonds for such improvement." What bonds are herein referred to? We find no suggestion in the act that they are to be other than the bonds of the county. We are not now considering the power of assessment or taxation to pay the bonds, but solely the question of whose obligations are authorized in the law. To say the bonds must have an obligor is to state a self-evident truth. The county commissioners are not authorized to issue any other. The spirit and letter of this act indicate the intention to authorize the execution and negotiation of these bonds "as other bonds of the county are negotiated." In determining whether the bonds are county obligations, the provisions of section 12 of the act are not to be lost sight of. By the terms of that section, if any bond or interest shall be due, and there is no money to pay the same, the commissioners are authorized to make a temporary loan to pay the same. The lien of the assessment for such temporary loan is to continue for the benefit of the county. Such provisions are generally held to be for the benefit of the holder of the obligation of the corporation which is thus empowered to raise money to meet a legal indebtedness. *Supervisors v. U. S.*, 4 Wall. 435, 18 L. Ed. 419; *City of Little Rock v. U. S.*, 43 C. C. A. 261, 103 Fed. 418; *Village of Kent v. U. S.*, 51 C. C. A. 189, 113 Fed. 232. While we are not now called upon to pass upon the question as to whether the commissioners can be compelled to exercise this authority in favor of bondholders, this feature of the law is entitled to weight, in view of the contention that it was the purpose of the act to impose no obligation upon the county beyond the collection and application of the assessments. It is the county that is here authorized to make loans to meet deficiencies in assessments in order that the bonds may be met at maturity. The commissioners represent the county, and no other political or corporate body. They are authorized to issue the bonds of that quasi corporation whose officers they are. The commissioners exercised this authority, and issued bonds which upon their face purported to be the obligation of the county. It is true that the act requires that, although the bonds shall be issued as other bonds for road improvement are issued, they shall bear the name of the street for whose improvement they are issued, and shall state therein that they are to be paid for by assessments upon the property abutting said improvements; but there is no requirement that they can be only paid for by such assessment, and no express limitation upon the undertaking of the county in issuing and selling these securities. The obligation to pay is unconditional, and there is no statement in the act or in the bond that the holder shall await payment until assessments can be collected. It is not unlikely that the bonds could not have been negotiated, had the act required, and the bonds stated that payment was to be made only from assessments. We do not think anything short of such clear expression of limitation of the right of the bondholder to the assessments on the property, without any general liability on the bonds by the county, will have the effect to thus restrict the obligation of the contract. *State v. Fayette Co. Board of Com'rs*, 37 Ohio St. 526; *U. S. v. Ft. Scott*, 99 U. S. 152, 25 L. Ed. 348; *U. S. v. Clark*

Co., 96 U. S. 211, 24 L. Ed. 628. These obligations upon which the money was received by the county being authorized by the law, and the county having defaulted in payment, a money judgment must be rendered upon the bonds unless some good defense is shown. It is claimed that the act under which the bonds were issued is unconstitutional, as being in contravention of article 26 of the constitution of Ohio, which provides that all laws of a general nature shall have a uniform operation throughout the state. Since the decision in *Hixson v. Burson*, 54 Ohio St. 470, 43 N. E. 1000, there can be no question as to this law falling within the category of those condemned as attempts to enact special legislation, when general laws having a uniform operation throughout the state can only be passed. *Hixson v. Burson* expressly overruled the prior decision of the Ohio supreme court in *State v. Board of Franklin Co. Com'rs*, 35 Ohio St. 459, holding legislation of the character of that now under consideration to be valid. The latter decision was the declared law of the state when these bonds were issued. As late as *Wilkes Co. v. Coler*, 180 U. S. 506, 21 Sup. Ct. 458, 45 L. Ed. 642, Mr. Justice Harlan, speaking for the supreme court, said :

"It is a settled doctrine in this court that the question arising in a suit in a federal court of the power of a municipal corporation to make negotiable securities is to be determined by the law as judicially declared by the highest court of the state when the securities were issued, and that the rights and obligations of parties accruing under such a state of law would not be affected by a different course of judicial decisions subsequently rendered, any more than by subsequent legislation. *Loeb v. Trustees*, 179 U. S. 472, 21 Sup. Ct. 174, 45 L. Ed. 280, and authorities there cited."

Up to the time of the issue of these bonds, acts similar to the one under consideration had been upheld by the supreme court of Ohio. The fact that the plaintiffs below purchased the bonds after the decision in *Hixson v. Burson* cannot affect its title as a bona fide holder if the bonds were issued under a law held to be valid at the time of the issue. *Gunnison Co. v. E. H. Rollins & Sons*, 173 U. S. 255, 19 Sup. Ct. 390, 43 L. Ed. 689.

It is further contended that the bonds are of no validity, as they are issued in violation of the guaranties of the constitution of the United States against taking private property without compensation, and depriving any person of property without due process of law. This argument is aimed against the feature of the law which undertakes to provide for assessments upon the property abutting upon the improvement. A similar question was before the supreme court in *Loeb v. Trustees*, 179 U. S. 488, 21 Sup. Ct. 174, 45 L. Ed. 280. In that case it was held that, even if the assessment was invalid because of the constitutional objection raised, the law could stand as valid, authorizing the making of obligations of binding force upon the township. Finding in this law authority to issue the bonds for purposes held to be lawful at the time the authority was granted, and the bonds having been issued accordingly, they became the obligations of the county, irrespective of the question—not herein involved—of the validity of any attempted assessments to pay the bonds. As was said by Mr. Justice Harlan in *Loeb v. Trustees*, supra :

"The relief asked and the only relief that could be granted in the present action is a judgment for money. If the township should refuse to satisfy a judgment rendered against it, and if appropriate proceedings are then instituted to compel it to make an assessment to raise money sufficient to pay the bonds, the question will then arise whether the mode prescribed by the third section of the act of 1893 can be legally pursued, and, if not, whether the laws of the state do not authorize the adoption of some other mode by which the defendant can be compelled to meet the obligations it assumed under the authority of the legislature of the state. All that we can now decide is that, even if the third section of the statute in question be stricken out as invalid, the petition makes a case entitling the plaintiff to a judgment against the township. Whether a judgment, if rendered, could be collected, without further legislation, depends upon considerations that need not now be examined."

What we hold is that the bonds in suit constitute a valid obligation of the county, upon which a judgment may be rendered in favor of the holder. Whether the same can be compelled to be paid through the assessments provided for in the act, or whether there exists legislation under which the commissioners can be required to levy a general tax for the payment of such judgment, are questions not made in this record, and upon which we express no opinion.

OREGON KING MIN. CO. v. BROWN et al.

(Circuit Court of Appeals, Ninth Circuit. October 6, 1902.)

No. 816.

1. MINING CLAIMS—MARKING LOCATION—STATUTORY REQUIREMENT.

Rev. St. § 2324 [U. S. Comp. St. 1901, p. 1426], which provides that in marking a mining claim "the location must be distinctly marked on the ground so that its boundaries can be readily traced," does not require the boundary lines to be indicated by physical marks or monuments, nor define what kind of marks shall be made, nor on what part of the ground claimed; but any marking, whether by stakes, mounds, monuments, or written notices, whereby the boundaries can be readily traced, is sufficient.

2. SAME—RECORD OF LOCATION NOTICE—OREGON STATUTE.

Under St. Or. Oct. 14, 1898, providing for the recording of notices of the discovery and location of mining claims, it is not essential to the validity of a location that the record should be a literal copy of the notice posted on the claim, but it is sufficient if it is a substantial copy.

In Error to the Circuit Court of the United States for the District of Oregon.

See 110 Fed. 728.

Cotton, Teal & Minor, for plaintiff in error.

Dolph, Mallory, Simon & Gearin and Albert Abraham, for defendants in error.

Before GILBERT and ROSS, Circuit Judges, and HAWLEY, District Judge.

ROSS, Circuit Judge. The Oregon King Mining Company, the plaintiff in error, commenced proceedings in the United States land office at The Dalles, Or., to procure a patent for a certain mining

claim, called the "Silver King." At the time of its application the company was in possession of the claim, and is so still. The defendants in error contested the application, and, in support of their adverse claim, commenced, pursuant to the provisions of section 2326 of the Revised Statutes [U. S. Comp. St. 1901, p. 1430], the present action in the court below to determine the conflicting claims to the ground, in which action judgment passed for the plaintiffs therein, the defendants in error here.

The plaintiff in error claims the ground by virtue of a location thereof made on the 24th day of June, 1898, by one G. M. Wilson. The defendants in error claim it under a location made on the 31st day of January, 1899, by T. J. Brown and Columbus Friend. Substantially the same ground is covered by both locations. That made by Wilson he called the "Silver King Mining Claim," and that made by Brown and Friend was called by them the "St. Elmo Mining Claim." The case shows that Brown, in connection with Friend, first undertook to locate the ground in controversy on the 10th day of March, 1897, but it is conceded that he did not make any valid location thereof prior to January 31, 1899, so that, if the location made by Wilson on June 24, 1898, was valid (to whose rights the plaintiff in error succeeded), the plaintiff in error is entitled to the property; it having entered into the possession thereof under Wilson's location, and having since retained such possession and worked and developed the claim, expending in such work and development a large sum of money.

At the time of the making of the location by Wilson there was no statute of the state of Oregon requiring any record to be made of a mining location, nor did any statute of that state then add to the requirements of the Revised Statutes of the United States in the matter of the making of locations of mining claims. But by an act of the legislature of Oregon approved October 14, 1898, and which took effect January 1, 1899, it was provided that any person who is either a citizen of the United States, or has declared his intention to become such, who discovers a vein or lode of mineral-bearing rock in place upon unappropriated public land of the United States within the state of Oregon, may locate a claim upon such vein or lode so discovered by posting thereon a notice of such discovery and location, which notice shall contain: First, the name of the lode or claim; second, the name or names of the locator or locators; third, the date of the location; fourth, the number of linear feet claimed along the vein or lode each way from the point of discovery, with the width on each side of said vein or lode; fifth, the general course or strike of the vein or lode, as near as may be. The boundaries of the claim are by the act required to be defined so that they may be readily traced, and they are required to be marked within three days after the posting of such notice by six substantial posts, projecting not less than three feet above the surface of the ground, and not less than four inches square or in diameter, or by substantial mounds of stone, or earth and stone, at least two feet in height. By section 2 of the act such locator is required to file for record with the recorder of conveyances, if there be one,—otherwise with the clerk of the county wherein the claim is situated,—a copy of the notice so posted by him upon the lode or claim,

within 30 days after the date of such posting, which notice is required to be immediately recorded by the officer. By section 3 of the act the locator is required, within 90 days from the date of posting his notice of discovery, to sink a discovery shaft upon the claim located, to a depth of at least 10 feet from the lowest part of the rim of such shaft at the surface, or deeper, if necessary, to show by such work a lode or vein of mineral deposit in place, with a provision to the effect that a cut or crosscut or tunnel which cuts the lode at a depth of 10 feet, or an open cut at least 6 feet deep, 4 feet wide, and 10 feet in length along the lode from the point where the same may be in any manner discovered, shall be deemed equivalent to such discovery shaft, and with a provision to the effect that such work shall not be deemed a part of the assessment work required by the Revised Statutes of the United States.

It appears from the record that the claim in controversy is located upon a large hill, devoid of timber and of vegetation, except a scanty growth of grass, on which a vein of mineral-bearing rock crops out and is clearly visible for a distance of more than 400 feet. It appears that this ledge was known to persons living in the vicinity thereof prior to the coming into the country of either Brown or Wilson, but apparently was not much thought of. About the 1st of March, 1897, Brown went to the vicinity for the purpose of making a visit to Friend. During the time of that visit the two made a trip to a sheep ranch, on their way to which Brown found float from the ledge, and stopped and began to prospect it. Friend said that it did not amount to anything, but Brown continued to examine the ledge while Friend proceeded to the sheep camp; and during his absence Brown erected a monument on the ground, and wrote out a notice of location in behalf of himself and Friend, which he placed in the monument, and took some of the samples of the rock to Friend's house. Shortly after this, and without doing any work upon the claim, Brown left the country, and remained away until about the 1st of September, 1897, when he returned with a man named Allen, whom he sought to interest in the claim; but after putting in some shots in the ledge and making some tests of the rock (which they made at the house of a Mr. Furnall, where they were staying), Allen concluded that it was not rich enough, and declined to take any interest in the claim. Brown and Allen then left. In September, 1897, Wilson, who had been out prospecting, stopped at Furnall's house; and on that occasion Furnall picked up a piece of rock from this ledge and said, "Here is a piece of rock I can either pan or mortar up and wash gold out of it." Wilson asked where the rock came from, and Furnall pointed to the hill where the ground in controversy is located. When Wilson left for his home he took with him a piece of the rock which Furnall gave him, and during the succeeding winter had it assayed, with the result that it showed a high value in gold. About the 1st of June, 1898, Wilson returned to the neighborhood with John Knight and J. F. Hubbard; first going to the house of Furnall, and afterwards to that of Friend. From there, Wilson, Knight, and Hubbard went up the hill in search of the ledge from which the rock given him by Furnall was taken. They found it, and also the monument and notice erected and posted by

Brown in behalf of himself and Friend in the preceding year. Wilson and Hubbard and Knight thereafter from time to time did work upon the ledge, consisting of small cuts, and took ore therefrom, which upon assay showed considerable value in gold and silver, and on the 24th day of June, 1898, put up at the east end of the Silver King claim a mound of rock taken from one of the cuts made by them, in which they placed a notice reading as follows:

"State of Oregon, County of Crook—ss: Know all men by these presents that I, the undersigned, has this 24th day of June, 1898, claimed, by right of discovery and location, 1,500 feet of linear and horizontal measurement in length, and 600 feet in width, a quartz ledge along the vein or lode thereof, 1,500 feet of said claim lying and being in westerly direction from the mound of stone of the discovery monument, with all dips, spurs, variations, and angles; said claim being more particularly described as follows: Situated on Sec. 30, T. 9, R. 17 E., Crook county, Oregon, near the Trout creeks. This claim shall be known as the 'Silver King.' Also I claim all water right to work the same.

"Discoverer:
"G. M. Wilson.

"Witnesses:
"J. F. Hubbard.
"John Knight."

There was evidence given on behalf of the defendant (plaintiff in error) tending to show that Wilson, Hubbard, and Knight then stepped to the west, intending to measure 1,500 feet, and in the west end set in the ground a juniper stake, about 4 inches square, so that it stood up out of the ground about 4 or 4½ feet,—the stake being set about on a line with the ledge; that on the east side of the stake they marked, "Silver King 1,500 feet easterly," and on its south side, "300 feet southerly," and on its north side, "300 feet northerly." Shortly after this the party left the country, and returned about the 1st of August of the same year, and sunk a shaft on the vein about 6 by 4 feet, and to a depth of 9 or 9½ feet. Wilson and Hubbard then left, leaving Knight at the claim for the purpose of shipping some ore therefrom to the smelter at Tacoma, which he did, to the extent of 5 tons, during the month of September, and from which was realized about \$125 per ton. A few days after getting this return, Knight went back to his home, at Pendleton, Or. In the early part of February, 1899, he returned to the claim, and found Brown in possession; Brown having been informed during January, 1899, by Mrs. Furnall, of the result of the ore shipment by Knight. Brown, contending that Wilson had no right to make a location of the ground in controversy, proceeded on the 31st day of January, 1899, to locate the same ground in behalf of himself and Friend; undertaking to mark and stake the boundaries thereof, and placing in the monument at the east end, alongside of Wilson's monument, a notice in these words and figures:

"Location Notice.

"State of Oregon, County of Crook: Know all men by these presents that we, the undersigned, have this 31st day of January, 1899, do locate this ledge of mineral-bearing quartz, commencing at this monument of stone, running 1,500 linear feet in a westerly direction to a stake. We also claim 300 linear feet on each side of center line along this ledge, with claim all dips, spurs, angles, and variations, being particularly described as follows: Sec. 30, T.

9, R. 17 E., Crook county, Oregon, $\frac{3}{4}$ mile east of Trout creek. This claim shall be known as the 'St. Elmo Mining Claim.'

"Witnesses:

"Nettle Friend.

"Anna Brown.

Locators:

T. J. Brown.

O. Friend."

The ground so located by Brown on the 31st day of January, 1899, was substantially the same ground undertaken to be located by Wilson on the 24th day of the previous June; and, according to the testimony of Brown himself, substantially the same ground was undertaken to be embraced by his lines, for the reason that he claimed to have been the first discoverer of the vein, and for the reason that he contended that Wilson's location was invalid.

Trout Creek mining district, in which is situated the ground in controversy, was organized in August, 1898; and on the 15th day of that month one James Wood was appointed deputy recorder for such district, under and in pursuance of the provisions of section 3831 of Hill's Annotated Laws of Oregon, which reads as follows:

"It shall be the duty of the county clerk of any county, upon the receipt of notice of a miners' meeting organizing a miners' district in said county, with a description of the boundaries thereof, to record the same in a book to be kept in his office as other county records, to be called a 'book of record of mining claims'; and upon the petition of parties interested, he may appoint a deputy for such district, who shall reside in said district or its vicinity, and shall record all mining claims and water rights in the order in which they are presented for record, and shall transmit a copy of such record at the end of each month to the county clerk, who shall record the same in the above-mentioned book of record, for which he shall receive one dollar for each and every claim. It shall further be the duty of said county clerk to furnish a copy of this law to his said deputy, who shall keep the same in his office, open at all reasonable times for the inspection of all persons interested therein."

This section of the Code was repealed by the Oregon act of October 14, 1898. Nevertheless Wood continued to act as such deputy recorder of mining claims until June 21, 1899. After the location by Brown and Friend of the ground in controversy as the St. Elmo claim on the 31st day of January, 1899, and the posting thereon of the notice by them last above set out, they gave to Wood a copy thereof for record. Wood had blank forms of his own, into which his practice was to incorporate the substance of mining notices filed with him for record, which he recorded in his record book, and thereafter forwarded the blank so filled in to the county clerk for record. He pursued that course with the notice filed with him by Brown and Friend; the notice so recorded in the book of records of the mining district, and forwarded by Wood to the county recorder, reading as follows:

"Notice is hereby given that the undersigned, being a citizen of the United States of America, and over the age of twenty-one years, and having complied with the requirements of chapter six of title thirty-two of the Revised Statutes of the United States, and the local customs, laws, and regulations, has located 1,500 feet linear and horizontal measurement in length, and 600 feet in width, on the lode or vein of mineral-bearing quartz, with all dips and spurs and angles; said lode being situated in the Trout Creek mining district, of Crook county, Oregon, and more particularly described as follows: Beginning at a monument of stone, and running 1,500 feet in a westerly course to a stake, with 300 feet of ground on each said [side] of said de-

scribed line, situated $\frac{3}{4}$ of a mile east of Big Trout creek, in Sec. 30, T. 9, R. 17 East. This claim shall be known as 'The St. Elmo.' Located this 31st day of January, 1899.

T. J. Brown and C. Friend, Locators.

"Witnesses:

"Nettle Friend.

"Anna Brown."

Brown remained in possession of the claim from the time of the location made January 31, 1899, until the 1st of April following, during which time he did some work upon it. Friend conveyed his interest therein to Brown on the 21st day of February of the same year, and thereafter Brown conveyed a half of his interest in the claim to the defendant in error Maddox. On the trial there was testimony tending to show that at the time of Brown's location, on the 31st day of January, 1899, the west end center stake claimed to have been placed by Wilson did not in fact exist. About the 1st of April, Brown left the claim, which was soon taken possession of by Wilson under his location of June 24, 1898, and has ever since been held by him and those claiming under him.

The fundamental questions contested at the trial in the court below, and presented by the record here, are: First, whether the Wilson location, made June 24, 1898, was properly marked upon the ground; and, second, if it was not, whether a copy of Brown's location of January 31, 1899, was recorded as required by the act of the state of Oregon of October 14, 1898. Other questions, of a minor character, also arose during the trial in the court below, which it will be unnecessary to consider, in the view we take of the case.

The case was tried with a jury. In the answer of the defendant to the plaintiff's complaint, it was, among other things, alleged: That Wilson, having on the 24th day of June, 1898, discovered therein a vein of rock in place, carrying precious metals, located a claim called the "Silver King Mining Claim," embracing the vein; so marking it that its boundaries could be readily traced; the same being "by the erection of a monument of stone at least two feet in diameter at its base, and four feet in height, which said monument was so erected and located at the east end center of said Silver King mining claim, and at the east end of said ledge, lead, lode, or vein of rock in place, and by making a cut into said ledge, lead, lode, or vein, and along the same, which said cut was 5 feet wide, 8 feet long, and 6 feet deep at the upper end thereof; and said Wilson then and there placed in a conspicuous place in said monument, at the east end center of said claim, a notice in words and figures" as hereinbefore set out. "That, at the point where said monument was so erected, said ledge, lead, lode, or vein of rock in place crops out, and forms a ridge upon the surface of the ground, and is plainly visible, and can be readily traced and followed in a straight line from said point for a distance of over 400 feet therefrom, in a westerly direction; said ground being barren and devoid of timber or vegetation, excepting only a scanty growth of grass. That the said G. M. Wilson at said time further distinctly marked said claim and the location thereof upon the ground, by placing a square stake at the west end center of said claim, and in a line with said ledge, lead, lode, or vein of rock in place, and an extension thereof, which said

square stake was firmly set in the ground, and projected at least 3 feet above the ground, and was at least 4 inches in diameter, and was so set in the ground that one of the sides thereof faced towards the said monument of stone at the east end center of said claim, and said face of said stake was plainly marked 'Silver King,' '1,500 feet easterly,' and the north face of said stake was plainly marked '300 feet northerly,' and the south face of said stake was plainly marked '300 feet southerly.' That said G. M. Wilson set said stake in a line with the croppings of said ledge, lead, lode, or vein of rock in place, and upon the extension thereof, and intended to set the same 1,500 feet westerly along said ledge, lead, lode, or vein, and an extension thereof from said monument of stone at the east end center of said claim, but miscalculated the distance thereof, and set said stake 1,368 feet westerly from said east end center monument. That said G. M. Wilson further at said time distinctly marked said claim and the location thereof upon the ground, by sinking a shaft upon the line of said croppings of said ledge, lead, lode, or vein of rock in place, and on a direct line between said discovery monument and said west end center stake, which said shaft was sunk to a depth of nine feet, and at a point about 400 feet westerly from the east end center, and also by running a crosscut about 50 feet long, connecting with said shaft."

At the trial the defendant (plaintiff in error here) requested the court to instruct the jury that, if Wilson marked his claim as alleged in the answer, such marking was a sufficient compliance with section 2324 of the Revised Statutes of the United States [U. S. Comp. St. 1901, p. 1426], and that Wilson's location, so far as marking was concerned, was therefore valid, which instruction the court below refused to give, to which action the defendant excepted. The court below, in more than one instance, against the objection and exception of the defendant, refused to determine the validity or invalidity of the Wilson location as a matter of law, but submitted that question to the jury as one of fact, under instructions as to the law by which they should be guided in determining the question. Concerning the necessary marking of the claim, the court said in its instructions:

"The test is not as to whether the notice would so describe the claim that it could be surveyed. The lines themselves must be indicated by physical marks or monuments, so that one unfamiliar with surveying, and without the aid of measuring instruments or a compass, can readily see by the marks themselves just what is claimed; that is to say, it is my opinion that it is not sufficient that a surveyor might go and find this claim, for the reason that the object of this notice and marking is to advise people who are in that country, and who are not surveyors, and in cases where it is not practicable to have that kind of service, to determine by observation, from what has been done upon the ground, that there has been a location, and its boundaries. The plain provision of the statute which requires a mining location to be so marked upon the ground that its boundaries can be easily traced is salutary and beneficial, and is not to be frittered away by construction. After the discovery, the marking is the main act of location. Without it the location is invalid."

The most of what was there said by the court below was correct and proper. The vice is in that part of the instruction in which the jury was clearly and distinctly told that the lines themselves must be indicated by physical marks and monuments, so that one unfamiliar with

surveying, and without the aid of measuring instruments, can readily see just what is claimed. The opinion entertained and given effect by the court below in its rulings in respect to the necessity of indicating the boundaries of the claim by physical marks or monuments, in order to constitute a valid location, is further shown by its refusal to give the following instructions requested by the defendant, to which exceptions were reserved:

"In regard to the manner of marking, I call your attention to the fact that the law does not require the boundaries of the claim to be marked. It is the location that must be marked, and the law does not say how it shall be marked, excepting that it must be distinctly marked, so that its boundaries can be readily traced; that is, the location must be designated by some means placed upon the ground, so that any one visiting the ground, and endeavoring to do so, can readily trace the boundaries of the location made."

"At the time Wilson attempted to make his location, the law did not prescribe or define what kind of markings he should make, or upon what part of the ground or claim he should place the same. He was not required to place such markings at the corners of the location. Any marking on the ground claimed, by means of stakes, mounds, and written notices, is sufficient, if thereby the boundaries of the location can be readily traced; and in this connection you have a right to take into consideration the character of the ground, and any natural conditions that may aid the markings placed upon the location in determining its boundaries, or which may assist in the tracing of the boundaries from any markings which may have been placed upon the same."

The statute under and by virtue of which such locations are made does not say that the boundaries shall be indicated by physical marks or monuments, nor in any particular or designated manner. The requirement is that the location shall be so distinctly marked on the ground as that its boundaries may be readily traced. Section 2324, Rev. St. U. S. [U. S. Comp. St. 1901, p. 1426]. It has been many times decided that any marking on the ground, whether by stakes, monuments, mounds, or written notices, whereby the boundaries of the location can be readily traced, is sufficient. The latest decision by the supreme court of the United States to that effect is found in the case of *McKinley Creek Min. Co. v. Alaska United Min. Co.*, 183 U. S. 563, 22 Sup. Ct. 84, 46 L. Ed. 331, in which the notice described each of two locations as "a placer mining claim 1,500 feet, running with the creek, and 300 feet on each side from center of creek known as 'McKinley Creek,' in Porcupine mining district." "These notices," which it appears were written upon a stump or snag in the creek, said Mr. Justice McKenna, delivering the unanimous opinion of the supreme court, "constituted a sufficient location. The creek was identified, and between it and the stump there was a definite relation, which, combined with the measurements, enabled the boundaries of the claim to be readily traced."

In *Gleeson v. Mining Co.*, 13 Nev. 442, 462, the court, speaking through Beatty, J., said:

"The object of the law in requiring the location to be marked on the ground is to fix the claim, to prevent floating or swinging, so that those who in good faith are looking for unoccupied ground in the vicinity of previous locations may be enabled to ascertain exactly what has been appropriated, in order to make their locations upon the residue. We concede

that the provisions of the law designed for the attainment of this object are most important and beneficent, and that they ought not to be frittered away by construction. But it must be remembered that the law does not, in express terms, require the boundaries to be marked. It requires the location to be so marked that its boundaries can be readily traced. Stakes at the corners do not mark the boundaries. They are only a means by which the boundaries may be traced. Why not, then, allow the same efficacy to the marking of a center line in a district, where the extent of a claim on each side of the center line is established by the local rules? It would be safer, and therefore better, to comply with the recommendations of the land office, and erect stakes at the corners of the claim; but, if the grand object of the claim is attained by the marking of a center line, we can see no reason why it should not be allowed to be sufficient. In this case the locators of the Paymaster marked the center line of their claim on the 10th of October, 1872. No miner, no man of common intelligence acquainted with the customs of the country, could have gone on the ground and seen the monument, notice, and work at the discovery point, and the two stakes, one three hundred feet southeast of the location monument, marked, 'Southeasterly stake of Paymaster,' the other twelve hundred feet northwest of the location monument, and marked, 'Northwesterly stake of Paymaster,' in a line with the croppings and with the discovery point, without seeing at a glance that they marked the center line of the claim. By the rules of the district and the laws of the land, he would have been informed that the boundaries of the claim were formed by lines parallel to the center line, and three hundred feet distant therefrom, and by end lines at right angles thereto. With this knowledge, he could easily have traced the boundaries, and, if such was his wish, ascertained exactly where he could locate with safety."

Judge Sawyer, in instructing the jury in the case of *North Noonday Min. Co. v. Orient Min. Co.* (C. C.) 11 Fed. 125, 6 Sawy. 299, 310, upon the point in question, said:

"To make a valid location under the statute, it is required that 'the location must be distinctly marked on the ground, so that its boundaries can be readily traced'; but the law does not define or prescribe what kind of marks shall be made, or upon what part of the ground claimed they shall be placed. Any marking on the ground claimed, by stakes and mounds and written notices, whereby the boundaries of the claim located can be readily traced, is sufficient. If the center line of a location of a lode claim lengthwise along the lode be marked by a prominent stake or monument at each end thereof, upon one or both of which is placed a written notice showing that the locator claims the length of said line upon the lode from stake to stake, and a certain specified number of feet in width upon each side of such line, such location of the claim is so marked that the boundaries may be readily traced, and, so far as the marking of the location is concerned, is a sufficient compliance with the law."

In speaking to the same point, Judge Hawley, in the case of *Book v. Mining Co.* (C. C.) 58 Fed. 106, 113, said:

"All the authorities agree that any marking on the ground by stakes, monuments, mounds, and written notices, whereby the boundaries of the location can be readily traced, is sufficient."

See, also, *Haws v. Mining Co.*, 160 U. S. 303, 318, 16 Sup. Ct. 282, 40 L. Ed. 436; *Southern Cross Gold & Silver Min. Co. v. Europa Min. Co.*, 15 Nev. 383; *Jupiter Min. Co. v. Bodie Consol. Min. Co.* (C. C.) 11 Fed. 667; *Hauswirth v. Butcher*, 4 Mont. 308, 1 Pac. 714; *Upton v. Larkin*, 7 Mont. 449, 17 Pac. 728; *Pollard v. Shively*, 5 Colo. 309; *Eilers v. Boatman*, 3 Utah, 159, 2 Pac. 66; *Du Prat v. James*, 65 Cal. 555, 4 Pac. 562; *Taylor v. Middleton*, 67 Cal. 656, 8 Pac. 594.

The error committed by the court below, above indicated, necessi-

tating the reversal of the judgment and the remanding of the case for a new trial, it becomes necessary to decide but one other of the questions presented by the appeal; and that is whether or not it be necessary that the copy of the notice of location required by the Oregon statute to be recorded be a literal and exact copy of the notice posted. We think it clear that it need only be a substantial copy. *Gird v. Oil Co.* (C. C.) 60 Fed. 531; *Myers v. Spooner*, 55 Cal. 257; *Doe v. Mining Co.*, 17 C. C. A. 190, 70 Fed. 457; *Metcalf v. Prescott* (Mont.) 25 Pac. 1038; *Preston v. Hunter*, 15 C. C. A. 148, 67 Fed. 996; *Carter v. Bacigalupi* (Cal.) 23 Pac. 363; *Deeney v. Milling Co.* (N. M.) 67 Pac. 724; *Lindi. Mines*, § 381; *Barringer & A. Mines & M.* p. 253. The judgment is reversed, and cause remanded for a new trial.

NEVADA NAT. BANK OF SAN FRANCISCO v. DODGE, Assessor, et al.

(Circuit Court of Appeals, Ninth Circuit. October 6, 1902.)

No. 794.

1. TAXATION—NATIONAL BANK STOCK—CALIFORNIA STATUTE.

The provision of Pol. Code Cal. § 3609, relating to the assessment and taxation of national bank shares, that in making the assessment to each stockholder there shall be deducted from the value of his shares "such sum as is in the same proportion to such value as the total value of its real estate and property exempt by law from taxation bears to the whole value of all the shares of capital stock in said national bank," is valid and enforceable, when construed in harmony with the other parts of the section and the express declaration therein that such shares shall not be taxed at a greater rate than other moneyed capital in the hands of individual citizens of the state; its purpose being to require the deduction from the total value of the bank stock, not only of the value of its real estate, which is taxable to the bank, but also of the value of all other property owned by the bank which would be exempt from taxation, under the laws of the state, in the hands of owners of other moneyed capital, and to thus fix the basis for the value of shares in the hands of the stockholders.

2. SAME—EXCESSIVE TAXATION OF BANK SHARES.

The provisions of Rev. St. § 5219 [U. S. Comp. St. 1901, p. 3502], that the taxation of national bank shares by a state shall not be at a greater rate than is assessed upon other moneyed capital in the hands of individual citizens of the state, does not require the state to conform its system of taxation with respect to local banking corporations to that applied to national bank shares, and it is not violated because a state taxes the property, instead of the shares, of domestic corporations.

3. SAME—CALIFORNIA STATUTE.

Pol. Code Cal. § 3609, construed, and held to give stockholders in national banks the right to the same deductions from the assessed value of their shares as is allowed to local banks and individual owners of other moneyed capital.

4. SAME—NOTICE OF ASSESSMENTS.

Stockholders of a national bank are required to take notice of the law of the state providing for the assessment and taxation of their shares, and of a general law creating a board of equalization and fixing the time and place where they may appear for the purpose of applying for a reduction of their assessments; and a notice required to be given to the bank of the assessment of the shares of its respective stockholders is sufficient notice to the stockholders, in connection with such statutory provisions.

Appeal from the Circuit Court of the United States for the Northern District of California.

T. I. Bergin, for appellant.

Franklin K. Lane, City Atty., and W. I. Brobeck, Asst. City Atty., for appellees.

Before GILBERT, Circuit Judge, and HAWLEY and DE HAVEN, District Judges.

DE HAVEN, District Judge. The appellant is a national banking association, with its principal place of business at San Francisco, in the state of California, and the bill of complaint in this case was filed by it to enjoin the assessment of its shares of stock to the individual owners thereof; and, the assessment having been made, supplemental bills were filed by it to restrain the collection of the taxes levied upon the assessed value of such shares. The case was submitted to the circuit court for decision upon the pleadings and upon an agreed statement of facts, and thereupon a decree was entered by that court dismissing the bill and supplemental bills. The assessment in question was made under an act of the legislature of the state of California, approved March 14, 1899 (St. 1899, p. 96), amending sections 3608 and 3609 of the Political Code of the state of California, and adding thereto a new section, numbered 3610. The sections referred to are as follows:

"3608. Shares of stock in corporations possess no intrinsic value over and above the actual value of the property of the corporation which they stand for and represent; and the assessment and taxation of such shares, and also all the corporate property, would be double taxation. Therefore, all property belonging to corporations, save and except the property of national banking associations not assessable by federal statute, shall be assessed and taxed. But no assessment shall be made of shares of stock in any corporation, save and except in national banking associations, whose property, other than real estate, is exempt from assessment by federal statute.

"3609. The stockholders in every national banking association doing business in this state, and having its principal place of business located in this state, shall be assessed and taxed on the value of their shares therein; and said shares shall be valued and assessed as is other property for taxation, and shall be included in the valuation of the personal property of such stockholders in the assessment of the taxes at the place, city, town, and county where such national banking association is located, and not elsewhere, whether the said stockholders reside in said place, city, town, or county, or not; but in the assessment of such shares, each stockholder shall be allowed all the deductions permitted by law to the holders of moneyed capital in the form of solvent credits, in the same manner as such deductions are allowed by the provision of paragraph six of section thirty-six hundred and twenty-nine of the Political Code of the state of California. In making such assessment to each stockholder, there shall be deducted from the value of his shares of stock such sum as is in the same proportion to such value as the total value of its real estate and property exempt by law from taxation bears to the whole value of all the shares of capital stock in said national bank. And nothing herein shall be construed to exempt the real estate of such national bank from taxation. And the assessment and taxation of such shares of stock in said national banking associations shall not be at a greater rate than is made or assessed upon other moneyed capital in the hands of individual citizens of this state.

"3610. The assessor charged by law with the assessment of said shares shall, within ten days after he has made such assessment, give written notice

to each national banking association of such assessment of the shares of its respective shareholders; and no personal or other notice to such shareholders of such assessment shall be necessary for the purpose of this act. And in case the tax on any such stock is unsecured by real estate owned by the holder of such stock, then the bank in which said stock is held shall become liable therefor; and the assessor shall collect the same from said bank; which may then charge the amount of the tax so collected to the account of the stockholder owning such stock, and shall have a lien, prior to all other liens, on his said stock, and the dividends and earnings thereof, for the reimbursement to it of such taxes so paid."

1. It is claimed by appellant that this statute is inoperative and void, because of the following direction contained in section 3609 of the Political Code, above set out:

"In making such assessment to each stockholder, there shall be deducted from the value of his shares of stock such sum as is in the same proportion to such value as the total value of the real estate and property exempt by law from taxation bears to the whole value of all the shares of capital stock in said national bank."

It is argued that this is a specific direction by which the assessor must be governed, and as all the property of a national bank, except the real estate owned by it, is exempt by law from state taxation, the deductions which are thus directed to be made, will leave nothing in value in the shares to assess, and, quoting the language for counsel for appellant:

"Thus is presented the case of a legislative mandate to exempt from assessment the whole subject of assessment. This construction renders the statute inoperative and void."

Unquestionably, if the sentence above set out is to be construed literally and without reference to the context, the proposition for which the appellant contends is not without support; but it is a general rule of construction that the intention of the legislature is to be collected from the whole and every part of the statute, and not from some particular clause or sentence therein, and, if it is possible so to do, its language must be so interpreted that the statute will be operative, and absurd and mischievous results avoided.

"It is one of the great maxims of interpretation to keep always in view the general scope, object, and purpose of the law, rather than its mere letter." *Rutledge v. Crawford*, 91 Cal. 533, 27 Pac. 779, 13 L. R. A. 761, 25 Am. St. Rep. 212.

"A rigid and literal meaning would in many cases defeat the very object of the statute, and would exemplify the maxim that 'the letter killeth, while the spirit keepeth alive.' Every statute ought to be expounded, not according to the letter, but according to the meaning; * * * and the intention is to govern, although such construction may not in all respects agree with the letter of the statute." *Tracy v. Railroad Co.*, 38 N. Y. 437, 98 Am. Dec. 54.

The object of the statute under consideration was to provide for the assessment and taxation of shares of stock in national banking associations, and it is expressly declared therein that:

"The assessment and taxation of shares of stock in said national banking association shall not be at a greater rate than is made or assessed upon other moneyed capital in the hands of individual citizens of this state."

Now, it is evident that the purpose of the legislature in further providing, in the same section, that in the assessment of their shares certain deductions should be allowed stockholders in national bank-

ing associations, was to carry out this express declaration that the taxation of such shares should not be at a greater rate than that assessed upon other moneyed capital. This being so, the particular sentence relating to such deductions, upon which appellant relies, should be construed as requiring the assessor to first deduct from the total value of all its shares of stock the value of the real estate and all other property owned by the national banking association which under the laws of the state would be exempt from taxation in the hands of owners of other moneyed or competing capital, and then to assess to each individual stockholder his proportionate part of the remainder. This construction brings the sentence under consideration in harmony with the other parts of the section in which it appears, and gives effect to the general object which the legislature had in view in the enactment of the statute.

2. Section 5219 of the Revised Statutes [U. S. Comp. St. 1901, p. 3502] provides that :

"The legislature of each state may determine and direct the manner and place of taxing all the shares of national banking associations located within the state, subject only to the two restrictions that the taxation shall not be at a greater rate than is assessed upon other moneyed capital in the hands of individual citizens of such state, and that the shares of any national banking association owned by non-residents of any state shall be taxed in the city or town where the bank is located, and not elsewhere."

It cannot be doubted that the state, in the taxation of shares of stock in national banking associations, must observe the restrictions contained in this section of the Revised Statutes. *People v. Weaver*, 100 U. S. 543, 25 L. Ed. 705; *Owensboro Nat. Bank v. City of Owensboro*, 173 U. S. 664, 19 Sup. Ct. 537, 43 L. Ed. 850. In the case last cited the court referring to section 5219 of the Revised Statutes [U. S. Comp. St. 1901, p. 3502], said :

"This section, then, of the Revised Statutes, is the measure of the power of a state to tax national banks, their property, or their franchises. By its unambiguous provisions the power is confined to a taxation of the shares of stock in the names of the shareholders and to an assessment of the real estate of the bank. Any state tax, therefore, which is in excess of, and not in conformity to, these requirements, is void."

The appellant contends that the statute of California relating to the assessment of shares in national banking associations is in conflict with that provision of the foregoing section of the Revised Statutes which declares that the taxation of such shares "shall not be at a greater rate than is assessed upon other moneyed capital in the hands of individual citizens of such state." The first ground urged in support of this proposition is that under the law of the state of California the shares of local banking corporations are not subject to taxation, but only the property of such corporations; and it is urged that this difference in the mode of assessment imposes upon the owners of shares in national banking associations a greater burden of taxation than is imposed upon stockholders in local banking corporations. It is true that under the system of taxation in force in the state of California, when all of the property belonging to a corporation is assessed to the corporation itself, the shares of such corporation are not assessable in the hands of individual share-

holders. Pol. Code Cal. § 3608. *People v. Badlam*, 57 Cal. 601. In the case just cited, Mr. Justice Ross, in delivering the opinion of the court, observed:

"Now, what is the stock of a corporation but its property, consisting of its franchise and such other property as the corporation may own? Of what else does it consist? If all this is taken away, what remains? Obviously nothing. When, therefore, all of the property of the corporation is assessed,—its franchise and all of its other property of every character,—then all of the stock of the corporation is assessed, and the mandate of the constitution is complied with."

And it was further said in the same opinion:

"To assess all the corporate property of the corporation, and also to assess to each of the stockholders the number of shares held by him, would, it is manifest, be assessing the same property twice,—once in the aggregate to the corporation, the trustee of all the stockholders, and again separately to the individual stockholders, in proportion to the number of shares held by each."

We are unable to see that, under the system of assessment provided for in the California statute, shares in national banking associations are valued higher in proportion to their real value than moneyed or competing capital of local banking corporations. The mode of assessing such shares directly to the owners thereof is certainly different from the indirect method of assessing the interest of stockholders of local banking corporations in the property of such corporations; but, under the statute as we interpret it, all property which, if owned by a local banking corporation or citizen of the state, would be exempt from taxation under the state law, is, when owned by a national banking association, to be deducted from the total value of its shares in ascertaining the value of such shares for the purpose of assessment. Under this mode of proceeding no greater burden of taxation is imposed upon capital invested in national banking associations than is placed upon competing moneyed capital in the hands of individual citizens or local banking corporations; and, this being so, there is no conflict between the statute of the state and section 5219 of the Revised Statutes [U. S. Comp. St. 1901, p. 3502]. In exercising the power conferred by this section of the Revised Statutes, the state is not required to change its system of taxation, and assess the shares of stock of its own local banking corporations directly to the holders thereof, so as to conform to the precise method which it follows in the assessment of shares of national banking associations. All that is required is that shares in national banking associations shall not be taxed by the state at a higher rate than other moneyed capital in the hands of individual citizens of the state. This was so expressly ruled in *Davenport Nat. Bank v. Davenport Board of Equalization*, 123 U. S. 85, 8 Sup. Ct. 73, 31 L. Ed. 94, in which case the supreme court, speaking through Mr. Justice Miller, said:

"It has never been held by the court that the state should abandon systems of taxation of their own banks, or of the money in the hands of other corporations, which they may think the most wise and efficient modes of taxing their own corporate organizations, in order to make that taxation conform to the system of taxing the national banks upon the shares of their stock in the hands of their owners. All that has ever been held to be necessary is that the system of state taxation of its own citizens, of its own banks, and of its own corporations shall not work a discrimination

unfavorable to the holders of the shares of the national banks. Nor does the act of congress require anything more than this. Neither its language nor its purpose can be construed to go any farther. Within these limits, the manner of assessing and collecting all taxes by the states is uncontrolled by act of congress."

It is further urged by the appellant that shareholders in national banking associations are not allowed by the statute under consideration to deduct from the value of the shares owned by them the amount of unsecured debts which they owe to bona fide residents of the state, while local banks and individuals are permitted, under the system of taxation in force in California, to make such deductions from the amount of unsecured solvent credits owned by them, and that in this respect the statute is in conflict with section 5219 of the Revised Statutes [U. S. Comp. St. 1901, p. 3502]. We think, however, that under section 3609 of the Political Code such deductions are allowed to the stockholders of national banking associations. It is therein provided that:

"In the assessment of such shares, each stockholder shall be allowed all the deductions permitted by law to the holders of moneyed capital in the form of solvent credits, in the same manner as such deductions are allowed by the provisions of paragraph six of section thirty-six hundred and twenty-nine of the Political Code of the state of California."

If it should be conceded, as is claimed by appellant, that this language is not sufficient to authorize the assessor to make such deductions from the value of shares in national banking associations as are permitted by law to the holders of moneyed capital in the form of solvent credits, because such shares are not solvent credits, still authority for making such deductions is found in the further provision that:

"The assessment and taxation of such shares of stock in said national banking association shall not be at a greater rate than is made or assessed upon other moneyed capital in the hands of individual citizens of this state."

In order to effect this object, the assessor not only may, but in our opinion he is required (in assessing shares of national banking associations) to, make all deductions from the value of such shares which are permitted in the assessment of moneyed or competing capital of local banks and individual citizens of the state. But, even if the statute made no provision for such deductions, it would not follow that the assessment of which appellant complains is void; for it does not appear that any of its stockholders was indebted to a bona fide resident of the state. *Albany Co. v. Stanley*, 105 U. S. 305, 26 L. Ed. 1044.

3. The appellant also contends that the statute under which its shares were assessed is void, in that it does not provide for notice to the stockholders of the proceeding by which the assessment of their shares is to be made, and does not give to them an opportunity to be heard in relation thereto. Section 3610 of the Political Code provides that:

"The assessor charged by law with the assessment of said shares shall, within ten days after he has made such assessment, give written notice to each national banking association of such assessment of the shares of its respective shareholders; and no personal or other notice to such shareholders of such assessment shall be necessary for the purpose of this act."

We are unable to assent to the proposition that the notice thus provided for is insufficient, when considered in connection with other sections of the Political Code of the state (sections 3672-3682), which provide for a board of equalization, with power to hear complaints respecting the justice of any assessment, and also prescribe the time and place when and where such complaints may be heard. The shares of national banking associations are assessed under a general law, of which the stockholders must take notice; and the time and place when and where a stockholder may appear for the purpose of applying for a reduction of the valuation placed upon his property is fixed by a general law, of which he must also take notice. This is, we think, under all of the authorities, sufficient notice of proceedings for the assessment and taxation of property. In the language of the supreme court in *Palmer v. McMahon*, 133 U. S. 669, 10 Sup. Ct. 324, 33 L. Ed. 772:

"The power to tax belongs exclusively to the legislative branch of the government; and when the law provides for a mode of confirming or contesting the charge imposed, with such notice to the person as is appropriate to the nature of the case, the assessment cannot be said to deprive the owner of his property without due process of law."

And in *Kentucky Railroad Tax Cases*, 115 U. S. 321, 6 Sup. Ct. 57, 29 L. Ed. 414, it was said:

"It has, however, been repeatedly decided by this court that the proceedings to raise the public revenue by levying and collecting taxes are not necessarily judicial, and that 'due process of law', as applied to that subject, does not imply or require the right to such notice and hearing as are considered to be essential to the validity of the proceedings and judgments of judicial tribunals. Notice by statute is generally the only notice given, and that has been held sufficient."

See, also, *Vail's Ex'rs v. Runyon*, 41 N. J. Law, 98; *Cooley, Tax'n*, pp. 265, 266.

It follows, from what has been said, that in our opinion the statute under which the assessment referred to in the bill of complaint was made is valid, and the decree of the circuit court should be, and accordingly is, affirmed.

RORICK V. RAILWAY OFFICIALS' & EMPLOYEES' ACC. ASS'N.

(Circuit Court of Appeals, Ninth Circuit. October 27, 1902.)

No. 818.

1. ACCIDENT INSURANCE—CONSTRUCTION OF POLICY—NOTICE OF ACCIDENT.

An accident policy, insuring only against "physical bodily injury resulting in disability or death," contained a provision that "notice of the accident causing the disability or death shall be given in writing * * * within 15 days from the date of the accident causing the disability or death, * * * and failure to give such notice within said time shall render void all claims under this policy." *Held*, that under such policy the time for giving notice did not commence to run until either disability or death resulted from an injury, until which time there was no "accident causing disability or death," which brought the case within its terms, and that where an insured received a blow on the head which did not cause disability at the time, and was regarded as a trivial injury, but which resulted a few days later in both disability and death,

a notice given four days after his death and within 10 days after his disability was in time.

2. SAME—ACCIDENT PRODUCING DEATH—IMMEDIATE DISABILITY.

An accident policy provided that the insurance thereunder should "extend only to physical bodily injury resulting in disability or death, * * * effected * * * solely by reason of and through external, violent, and accidental means, * * * which shall, independently of all other causes, immediately, wholly, totally, and continuously from the date of the accident causing the injury disable the insured, and prevent him from doing and performing any work," etc. It further provided that there should be no liability for more than one of the losses specified, on payment for any one of which the policy should terminate, and the first loss specified was "loss of life occurring within 90 days from the date of the accident causing the fatal injury." *Held*, that such provisions could not be construed to exempt the insurer from liability for death resulting from an accidental injury within 90 days, because such accident did not produce "immediate, total, and continuous" disability.

Gilbert, Circuit Judge, dissenting.

In Error to the Circuit Court of the United States for the Southern District of California.

Hunter & Summerfield and Works, Lee & Works, for plaintiff in error.

George E. Otis, for defendant in error.

Before GILBERT and ROSS, Circuit Judges, and HAWLEY, District Judge.

ROSS, Circuit Judge. The plaintiff in error, who was plaintiff in the court below, is the beneficiary named in an accident policy of insurance issued by the defendant in error upon the life of the husband of the plaintiff in error, David G. Rorick, by occupation a passenger train conductor, insuring him against "physical bodily injury resulting in disability or death, as hereinafter (in the policy) expressed, and which shall be effected while this contract is in force, solely by reason of and through external, violent, and accidental means, within the terms and conditions of this contract, and which shall, independently of all other causes, immediately, wholly, totally, and continuously, from the date of the accident causing the injury, disable the insured, and prevent him from doing or performing any work, labor, business, or service, or any part thereof, within the conditions of this contract." The policy also declares that "no liability by reason of any accident is assumed for more than one of the losses below specified; and payment for any one of such losses shall immediately terminate this policy and all liability hereunder." This latter clause is followed by an enumeration of injuries that are covered by the insurance, the first of which is "loss of life occurring within ninety days from the date of the accident causing the bodily injury"; and a subsequent provision declares that, "should death result solely from such physical bodily injury within the conditions of this contract, said association will pay at its home office, as provided herein, the principal sum of five thousand dollars to wife, Issola Rorick, if living,

¶ 2. Risks and causes of loss under accident insurance policies, see note to *Society v. Dolph*, 38 C. C. A. 3.

otherwise to the legal representatives of the insured." This latter clause is the only one contained in the policy giving any right to the plaintiff in error. Among its provisions is one in respect to notice, as follows:

"Notice of the accident causing the disability or death shall be given in writing, addressed to the association, at Indianapolis, Indiana, within fifteen days from the date of the accident causing the disability or death, stating the name, occupation, and address of the insured, with date and full particulars of the accident causing the disability or death, and causes thereof; and failure to give such notice within said time shall render void all claims under this policy."

It is also declared therein that "all the terms and conditions of this contract are conditions precedent."

It appears from the second amended complaint of the plaintiff in error, to which a demurrer interposed by the defendant insurance company was sustained by the court below, that between the 11th and 14th days of March, 1900, and while the policy was in full force, the insured received bodily injury, to wit, "traumatic injury of the cranium, at the vortex thereof, which, independently of all other causes, produced and caused his death within ninety days thereafter, to wit, on the 26th day of March, 1900, at the county of San Bernardino, state of California; that the said injury was effected solely by reason of and through external, violent, and accidental means within the terms and conditions of said policy." The plaintiff in her second amended complaint also alleged that the injury to her husband occurred while he was acting as conductor of a passenger train of the Atchison, Topeka & Santa Fé Railway Company, and was caused by his raising his head and thereby striking a bolt or other iron in a railway car; that the injury was at the time supposed to be trivial, and not such as did or would result in either his disability or death; that there was no visible or outward sign of injury resulting from the accident, and that the deceased, notwithstanding it, continued thereafter for six days to perform his duties as such conductor; that he suffered severe pains in the head, which increased in violence until his death, and that on the 20th day of March, 1900, he did, as a direct and proximate result of his said injury, become insane, which condition continued until his death; that on the 21st day of March, 1900, physicians were called, and found the insured suffering as aforesaid, and pronounced his disease acute neuralgia; that neither the deceased nor the plaintiff in error knew or believed, and had no reason to believe, that his sickness or suffering was caused by the accident, nor did the attending physicians of the deceased attribute the same to the injury so received by him; that the fact that the death of the deceased was caused by the injury mentioned was first discovered by and as the result of an autopsy held by the physicians immediately after the death of the insured; that within four days after said discovery the plaintiff in error notified the defendant insurance company of the injury and consequent death of the insured, as required by the provisions of the policy; and a compliance with all of its other provisions is also alleged.

It will be observed that according to the averments of the complaint, the defendant company was not notified of the accident within 15 days

from the time the insured is alleged to have struck his head, and it was upon that ground that the court below sustained the demurrer, saying in its opinion:

"The notice agreed upon, it will be observed, is a notice of the accident, and the time allowed for giving it, 'within fifteen days,' runs from the date of the accident. These provisions, unlike corresponding provisions of the policies sued on in some of the cases cited by plaintiff, are neither obscure nor ambiguous, but clear and imperative. Nor does the notice belong to that class which courts decline to enforce because of unreasonableness, such as notices of disability or death, where the contingency happens after the limitation has expired. In a case such as those last mentioned it may well be held that notice within the time specified, being impossible, was not contemplated by the parties to the contract. The alleged insanity of the insured, whatever might have been its effect as an excuse for his failure to give the prescribed notice, had he survived and himself sued to recover damages resulting from his own disability, is not available in the present action for the purpose indicated, for the reason that the plaintiff herself should have given the notice."

It must be remembered that it was not every accident that was insured against, but only such as should result in the disability or death of the assured. Until one or the other of those things happened as a result of the striking of the head of the deceased, there was no accident to him within the terms of the policy in suit, and therefore nothing for which the insurer was required to be notified. Within 15 days of the disability of the deceased resulting from the striking of his head, and within 4 days after the autopsy upon his body disclosed the cause of his death, the plaintiff, according to the averments of the complaint, gave the notice specified in the policy. The accident covered by the policy was not complete until the hurt resulted in the disability or death of the insured; and, according to the averments of the complaint, both his disability and death occurred less than 15 days prior to the giving of the notice.

We do not understand counsel for the defendant in error to contend that under the policy in suit no liability for the death of the insured arose because the striking of his head against the bolt was not productive of immediate, total, and continuous disability. The suggestion of our Brother GILBERT, in his dissenting opinion, that that is the plain meaning of the contract of insurance, calls for a further reference to the policy. So far as pertinent to the suggestion, the policy is as follows:

"The insurance under this policy shall extend only to physical bodily injury resulting in disability or death, as hereinafter expressed, and which shall be effected, while this contract is in force, solely by reason of and through external, violent, and accidental means, within the terms and conditions of this contract, and which shall, independently of all other causes, immediately, wholly, totally, and continuously from the date of the accident causing the injury disable the insured, and prevent him from doing or performing any work, labor, business, or service, or any part thereof, within the conditions of this contract. No liability by reason of any accident is assumed for more than one of the losses below specified, and payment for any one of such losses shall immediately terminate this policy and all liability hereunder.

"Accidental Injuries Insured Against, Subject to the Definitions and Conditions Below, and Payments Therefor. (1) Loss of life, occurring within ninety days from the date of the accident causing the fatal injury. (2) Loss of both hands, occurring within ninety days from the date of the accident

causing the injury. (3) Loss of both feet, occurring within ninety days from the date of the accident causing the injury. (4) Loss of one hand and one foot, occurring within ninety days from the date of the accident causing the injury. (5) Loss of both eyes (meaning absolute, total, and permanent blindness, and provided the insured possessed the sight of both eyes at the date of the injury), caused by one accident and within ninety days of the accident causing the injury. (6) Immediate, continuous, and total disability for life, caused by one accident. (7) Loss of either foot or either hand, occurring within ninety days from the date of the accident causing the injury. (8) Loss of one eye (meaning absolute, total, and permanent blindness), occurring within ninety days from the date of the accident causing the injury. (9) Loss of time, per week, for a term not exceeding 104 consecutive weeks, when immediately, continuously, and wholly disabled. The payment for loss under provisions 1, 2, 3, 4, and 5, above specified, shall be the full principal sum named herein. The payments for loss under provisions 6 and 7, above specified, shall be one-half of the principal sum named herein. The payment for loss under provision 8, above specified, shall be one-fourth of the principal sum named herein. The payment for loss of time, under provision 9, above specified, shall be at the rate of twenty-five dollars per week, not to exceed his average weekly wages, payable as hereinafter provided. Neither the insured nor his beneficiary shall be entitled to indemnity under any of the provisions 1 to 8, inclusive, above specified, for any injury received while the insured is claiming or receiving indemnity under provision 9 of this policy. Should death result solely from such physical bodily injury, within the conditions of this contract, said association will pay, at its home office, as provided herein, the principal sum of five thousand dollars to wife, Issola Rorick, if living, otherwise to the legal representatives of the insured.

"Definitions and Conditions. (Subject to the following provisions hereof this policy is noncontestable, also nonforfeitable, as to any change of occupation.) * * * By loss of hand or hands, or a foot or feet, is meant the actual severance of the hand or hands, foot or feet, above the wrist or ankle. By total disability for life is meant immediate, continuous, total inability to perform any and every kind of labor or work, whereby the insured might obtain a livelihood; and no claim for such disability shall arise until it shall have immediately and continuously existed for a period of two years from the date of the accident causing such disability. By wholly disabled is meant immediate, continuous, total inability to perform any work, labor, business, or service, or any part thereof, from the date of the accident causing the injury. If any injury resulting in rupture, or hernia, shall cause disability or death, entitling the insured or his beneficiaries to claim indemnity of this policy, or if any injury entitling insured or his beneficiaries to claim indemnity under this policy be caused or contributed to, by contract [contact] with poisonous substances, or by handling or using dynamite or other explosives, or by being engaged in gymnastic or athletic sports, or by exposure to unnecessary danger or perilous venture (except in an effort to save human life), whether the insured did or did not anticipate injury or death to result from such exposure or perilous venture, or by sunstroke or freezing, or by gas or poison in any form or manner, or by anything leaving no external or visible mark of contusion or wound upon the body sufficient to cause death (drowning only excepted), and it shall appear by an autopsy that such injury contributed to the death of the insured, then, in each and every such case, the limit of the association's liability shall be one-fourth of the sum otherwise payable, anything to the contrary herein notwithstanding. If any injury causing disability or death, entitling the insured to claim benefits under the provisions of this policy, be caused or contributed to by quarreling, or by fighting, or by the intentional act of any person other than the insured, or by the act of any person who at the time was insane, or by the sting or bite of a spider, bug, or insect, or by the use of intoxicants or narcotics, or by war or riot, or by any surgical operation of any medical, dental, or mechanical treatment, except by amputation rendered necessary by an accidental injury and made within ninety days from the date of the event causing the injury, then, in each and every such case, the limit of the association's liability shall be one hundred dollars for fatal injury, or the gross sum of

ten dollars for nonfatal injury, anything to the contrary herein notwithstanding.

"Increase of Hazard. If the injured be fatally or nonfatally injured, within the intent and meaning of this policy, while engaged, temporarily or otherwise, in any occupation or work or risk classified by this association as more hazardous than that under which this policy is issued, or while doing any part of the work of any one so classified, or while exposed to any risk classified by this association as more hazardous than that under which this policy is issued, then, in such case, the association's liability shall not exceed such an amount as the premiums paid will purchase for such more hazardous occupation or work or risk, according to the classification of risks and premium rates and limits of this association. The classification of risks of this association is hereby made a part of this contract. If the insured be injured fatally or nonfatally while engaged, temporarily or otherwise, in any occupation or work or risk not classified by this association, this association's liability shall be rated upon the basis of the most hazardous occupation or work or risk mentioned in the classification of risks of this association: provided, however, if the insured shall have made an extra payment for extra weekly indemnity, such extra payment shall be excluded in ascertaining the amount due as benefits under provisions 1 to 8, inclusive, of this policy. If he be killed or sustain any of the losses enumerated in said provisions in a more hazardous occupation or work or risk than that named in this policy. The death of the insured shall immediately terminate all liability under this policy under provision 9 hereof; and in no case shall the insured be entitled to recover for more than a total of 104 weeks hereunder. Upon the payment of the sum insured under the provisions 1, 2, 3, 4, 5, 6, 7, and 8 hereof, all further liability of the association shall immediately cease, and this policy be thereby terminated."

It is thus seen that throughout the policy the insurance contracted for was against physical bodily injury "resulting in disability or death." Varying provisions are made for compensation in the event of the loss of certain members of the body within 90 days from the date of the accident causing the injury, and other and different provisions in the case of total, immediate, and continuous disability. Naturally, the first of those various injuries covered by the insurance (being the most serious) is "loss of life, occurring within ninety days from the date of the accident causing the fatal injury." There is here no provision or suggestion that "loss of life, occurring within ninety days from the date of the accident causing the fatal injury," is not insured against, unless the injury also causes "total, immediate, and continuous disability." The necessary effect of reading into the policy by construction such a limitation would be to make it mean that the insurer assumed no risk on account of the death of the insured, unless the fatal injury also "immediately, continuously, and totally" disabled him; in other words, that under the policy in suit there must be both death "and" disability before any liability for death can arise. Yet the contract in express terms declares that the insurance shall extend to physical injury resulting in either disability "or" death. Moreover, it would be contrary to a thoroughly and well settled rule to read by judicial construction into a policy prepared by the insurer a limitation in its favor and against the insured, especially when to do so would exonerate it from a loss for which it in express terms contracted to pay.

We are of the opinion that the notice alleged to have been given by the plaintiff in error was in time, and accordingly the judgment is reversed, and the cause remanded to the court below, with directions

to overrule the demurrer to the second amended complaint, with leave to the defendant thereto to answer.

GILBERT, Circuit Judge (dissenting). Did the accident occur on the date when the insured received the injury to his head, or did it occur later, when he became disabled as a result of that injury? I submit that in all cases of accident insurance the accident insured against is the occurrence of the bodily injury "through external, violent, and accidental means," which becomes the cause of the death or disability of the insured, and that the accident in this case occurred when the insured received the blow which in its subsequent development produced disability, insanity, and death. After such an injury is inflicted, it cannot be said, with any due regard to the meaning of the language employed in the policy, that the development of the injury or any of its subsequent changing phases may be regarded as the accident which is insured against. The date when the insured in this case became disabled by reason of the suffering in his head was not the date of his accident. That disability so developed on that date was not the result of any "external, violent, or accidental means" occurring on that date, but was the natural result and progress of an injury which had occurred six days prior thereto. Suppose the injury, at first apparently trivial, had gradually and during a period of six days developed into disability; could it be said that such development in any of its stages constituted an accident subsequent to the happening of the injury which was its cause? It may well be doubted whether the policy of insurance in this cause renders the defendant in error liable for an accident of the nature of that which occurred to the insured. In the policy it is stipulated as follows:

"The insurance under this policy shall extend only to physical bodily injury resulting in disability or death, as hereinafter expressed, and which shall be effected, while this contract is in force, solely by reason of and through external, violent, and accidental means, within the terms and conditions of this contract, and which shall, independently of all other causes, immediately, wholly, totally, and continuously, from the date of the accident causing the injury, disable the insured, and prevent him from doing or performing any work, labor, business, or service, or any part thereof, within the conditions of this contract."

The parties to the contract had the right to stipulate that the insurance company would be liable for no accident which did not produce immediate disability. They might agree that the company would assume no responsibility for an accident which was deemed trivial at the time when it occurred, but which at a subsequent date might develop into disability. They have used such language in this contract, and have declared as clearly as words could express it that the company assumes no risk whatever for death or disability resulting from an accident which was not productive of immediate and continuous disability or death; and none of the other provisions of the policy, in my judgment, is inconsistent with or operates to modify this plain provision.

But, whatever may have been the liability assumed by the defendant in error, I think it is clear that in this case the notice demanded by the policy was not given. The required notice was not a notice of

the cause of the disability or death, but a notice of the accident itself, and of its cause. As was stated by the trial court, the exacted notice was not of the class of those which are held void as being unreasonable. The notice not having been given within the stipulated time, I think the defendant in error is absolved from liability.

UNITED STATES v. GENTRY.

(Circuit Court of Appeals, Eighth Circuit. November 10, 1902.)

No. 1,757.

1. TRESPASS—CUTTING TIMBER—JUSTIFICATION NOT ESSENTIAL TO PROOF THAT TRESPASS NOT WILLFUL.

The test which determines whether one was a willful or an innocent trespasser is not his violation of or compliance with the law, but his honest belief and actual intention at the time he committed the trespass, and neither a justification of his acts nor any other complete defense to them is essential to establish the fact that he was not a willful trespasser.

2. SAME—EVIDENCE OF INTENTION AND GOOD FAITH.

Where the good faith or intention of a party in an affair is in issue, his acts and sayings in relation to it at or about the time of the transaction generally constitute the best evidence, and are always competent and material.

3. SAME—CUTTING TIMBER—CONSTRUCTION OF SECRETARY'S RULE AS TO SALES UNDER ACT JUNE 3, 1878.

The rule of the secretary of the interior that one who takes timber from the mineral land of the United States under the act of June 3, 1878 (20 Stat. 88 [U. S. Comp. St. 1901, p. 1528]), shall not sell or dispose of it without taking a written agreement from the purchaser that it shall not be used except for building, agricultural, mining, or domestic purposes within the state or territory, requires the vendor to take the agreement before or at the same time when he sells or disposes of the timber, and obtaining the written contract three months after the sale and delivery is not a substantial compliance with the rule.

4. SAME—FULL COMPLIANCE WITH THE ACT OF 1878 REQUISITE TO JUSTIFICATION THEREUNDER.

The rule is that one who takes timber from the public domain is a willful trespasser, and a full and fair compliance with the requirements of the act of June 3, 1878 [U. S. Comp. St. 1901, p. 1528], and with the rules prescribed by the secretary of the interior thereunder, is essential to justify the taking of timber from the public domain under that act.

5. PLEADING—AMENDED SUPERSEDES ORIGINAL COMPLAINT.

An amended complaint, which is complete in itself, and which does not refer to or adopt the original complaint as a part of it, entirely supersedes its predecessor, and becomes the sole statement of the plaintiff's cause of action.

6. ERROR NOT DISREGARDED UNLESS ABSENCE OF PREJUDICE IS CLEAR BEYOND DOUBT.

The presumption is that error produces prejudice. It is only when it appears so clear as to be beyond doubt that the error challenged did not prejudice, and could not have prejudiced, the complaining party, that the rule that error without prejudice is no ground for reversal is applicable.

Caldwell, C. J., dissenting.

(Syllabus by the Court.)

In Error to the District Court of the United States for the District of Colorado.

This is the second appearance of this case in this court. The judgment on the first trial was reversed, because in an action for the recovery of damages for the conversion of timber a verdict and judgment for the recovery of lumber and logs were rendered without any pleading of such a cause of action, or any prayer for such relief. Before the second trial was had, the complaint in conversion was superseded by an amended complaint, which set forth a cause of action in replevin, and prayed for the recovery of 539,505 feet of lumber and 300 saw logs, or for the sum of \$5,000, the value thereof. The defendant, Gentry, answered this new cause of action that the lumber and logs were his; that he had lawfully taken them from the mineral lands of the United States, in compliance with the terms of the act of congress of June 3, 1878 (20 Stat. 83 [U. S. Comp. St. 1901, p. 1523]);⁴ that he had taken them in good faith in the honest belief that he had a lawful right to do so; that the lumber and logs had been taken from him by the United States marshal under color of the authority of the circuit court, and that their proceeds were in its registry. He prayed that he might be adjudged to be the owner of the lumber and logs, and that their proceeds in the registry of the court might be paid over to him. The plaintiff put at issue the averments of the amended answer, and the case proceeded to its second trial. At this trial it conclusively appeared that the logs and lumber of which the defendant had possession when the action was commenced had all been taken from him by the United States marshal under a writ of replevin issued in this action without authority and in violation of the statutes and practice of Colorado (Gentry v. U. S., 101 Fed. 51, 53, 41 C. C. A. 185, 187); that, pursuant to an order of the court, the marshal had sold this property, and that the net proceeds of the sale, which, with interest, amounted to more than \$3,600, had been deposited in the registry of the court to the credit of the cause, to abide its final determination. Notwithstanding these pleadings and facts, and the plain issue relative to the disposition of this sum of money, the court instructed the jury at the close of the trial that this was an action by the United States to recover damages for the conversion of the lumber and logs; that, if the defendant had complied with the act of June 3, 1878, they ought to find a verdict in his favor; that, if he had failed in compliance, but was an unintentional trespasser, they should return a verdict against him for the value of the timber in the trees, and that, if they found that he was a willful trespasser, they should render a verdict against him for the full value of the manufactured lumber, as it was at the commencement of the action. Under these instructions the jury returned a simple verdict for the defendant, without determining the ownership of the logs and lumber seized, or of their proceeds in the registry of the court, and a judgment that the defendant go hence without day has been rendered. The writ of error which the United States has sued out challenges this judgment.

Glenn E. Husted and Henry C. Lewis (Marsden C. Burch, on the brief), for plaintiff in error.

Charles D. Hayt (Clyde C. Dawson, on the brief), for defendant in error.

Before CALDWELL, SANBORN, and THAYER, Circuit Judges.

SANBORN, Circuit Judge, after stating the case as above, delivered the opinion of the court.

The chief complaint of the government concerning the trial of this case is that the defendant was permitted to introduce certain evidence tending to show an alleged compliance on his part with the act of June 3, 1878 [U. S. Comp. St. 1901, p. 1528], and that the jury was instructed that, if they believed from this evidence that the defendant

had substantially complied with that act and with the rules adopted by the secretary of the interior thereunder, he would be entitled to their verdict. The act of June 3, 1878, provides that any bona fide resident of the state of Colorado may fell and remove timber from the mineral lands of the United States for mining, agricultural, and domestic purposes within that state in accordance with the terms of that act and the rules of the secretary of the interior prescribed thereunder. The complaint of the government is founded upon the following rule:

"Every owner or manager of a sawmill, or other person felling or removing timber under the provisions of this act, shall keep a record of all timber so cut or removed, stating time when cut, names of parties so cutting the same or in charge of the work, and describing the land from whence cut by legal subdivisions if surveyed, and as near as practicable if not surveyed, with a statement of the evidence upon which it is claimed that the land is mineral in character and stating also the kind and quantity of lumber manufactured therefrom, together with the names of parties to whom any such timber or lumber is sold, and shall not sell or dispose of such timber or lumber made from such timber, without taking from the purchaser a written agreement that the same shall not be used except for building, agricultural, mining or other domestic purposes within the state or territory; and every such purchaser shall be required to file with said owner or manager a certificate, under oath, that he purchases such timber or lumber, exclusively for his own use and for the purposes aforesaid."

The evidence, the introduction of which is assigned as error, is that about September 10, 1898, the defendant made an oral agreement with a certain mining company to sell it lumber to timber the Mabel-Grace mine from time to time as this lumber should be needed for that purpose; that he delivered about 1,500 feet of lumber under this agreement; that he was then stopped from proceeding with his contract by the writ of replevin; that afterwards, and on January 10, 1899, he procured a written agreement from this purchaser to the effect that this lumber had been and would be used for the purpose of timbering its mining property in the state of Colorado, and for no other purpose; that he made a similar oral agreement about September 6, 1898, for the sale of lumber to one Swope, a road overseer, and sold him 720 feet of lumber to improve the county road; that about January 7, 1899, Swope made a written contract to use this lumber for that purpose only; that these purchasers made certificates in the year 1899 that the timber they bought of the defendant was purchased to be used for the purposes stated in their respective agreements; that as the defendant cut the logs from which this lumber was manufactured he made daily memoranda on slips of paper of the number of feet cut, where it was cut, and who cut it, and filed them in his office; that after his business was stopped by the seizure of the lumber by the marshal he made up from these slips a record in a book which was received in evidence, and which contained the statements of fact required to be recorded by the rule which has been quoted, and that after this record was completed he destroyed the slips. The objections to the various items of this evidence are many and varied, but they are all founded on the proposition that it did not tend to show a compliance with the rule of the secretary under consideration. For the purpose of the decision of this case, but with-

out deciding or intimating any opinion upon that question, it is conceded that there are some parts of this evidence which did not tend to establish such a compliance. There was, however, another ground upon which all this evidence was admissible, and that was that it had a clear tendency to show the good faith and innocence of the defendant. One of his defenses was that he took this timber in good faith, with an honest belief that he had a lawful right to do so. That defense raised a material issue,—the issue whether the measure of the right of the government, if it had any right, was the value of the timber in the trees or its value in the manufactured lumber. The test to determine whether one is a willful or an innocent trespasser is not his compliance with the law, but his honest belief and his actual intention at the time he commits the trespass. Neither a justification of his acts nor any other complete defense to them is essential to the proof that he who committed them was not a willful trespasser. And, when the good faith or the intent of a party in a given affair is in issue, his acts and sayings in relation to it at about the time of the transaction generally constitute the best evidence of the fact, and are always competent and material. In view of this issue there was no error in the admission of any of the evidence here challenged. *U. S. v. Homestake Mining Co.* (C. C. A.) 117 Fed. 481; *Durant Min. Co. v. Percy Consol. Min. Co.*, 93 Fed. 166, 168, 169, 35 C. C. A. 252, 254.

This rule of the secretary of the interior requires that the owner or manager of a sawmill "shall not sell or dispose of such timber or lumber made from such timber, without taking from the purchaser a written agreement that the same shall not be used except for building, agricultural, mining, or other domestic purposes within the state or territory." The defendant sold and disposed of three lots of lumber, which were delivered to the road overseer and to the owner of the Mabel-Grace mine in September, 1898, without taking the written agreements required by this rule until some time in January, 1899. It is assigned as error that the court instructed the jury that they might find from these facts a substantial compliance with the rule, and might return a verdict for the defendant. Is it a substantial compliance with a rule that no sale or disposal of property shall be made without taking a written agreement, to sell and dispose of the property without procuring any such agreement, and then to obtain one three or four months after the sale or disposition of the property has been effected? It is said that the rule does not specify the time when the agreement shall be taken; that it does not require it to be taken before or at the time of the sale or disposal of the property; and that the procuring of the agreements three months after the sales was a literal fulfillment of the requirements of the rule, especially in view of the fact that these were continuing contracts, agreements to sell and deliver the lumber from time to time as the purchasers should need and order it. But, when the terms and purpose of the rule are considered, it seems clear that this cannot be the intent with which the secretary prescribed this requirement, nor can it be its true interpretation. The natural and rational meaning of the prohibition of one act without the doing of another is that the first shall not be done unless before or at the same time when it is done the second is also completed. The manifest pur-

pose of this inhibition strongly indicates that it was intended to be used and was used in this, its customary, signification. The object of the rule was to require the person who was taking timber from the mineral lands of the government to keep a record of his transactions, and written agreements from his purchasers, to the end that the inspectors of the government might see by an examination of these writings whether or not he was complying with the act of congress. The general rule was and is that he who takes timber from the lands of the United States is a willful trespasser. The act of 1878 carves an exception out of this rule, and gives to the bona fide residents of Colorado and some other states the lawful authority to fell and remove timber from the mineral lands of the government for certain purposes, subject to the rules prescribed by the secretary of the interior. It is only when the bona fide resident fairly and fully complies with the requirements of the act and of the rules promulgated by the secretary that he excepts himself from the general rule that all takers are trespassers, and removes himself from their class. When the portion of the rule which declares that such a resident shall not sell or dispose of the timber or lumber he cuts without taking a written agreement from the purchaser that the same shall not be used except for the purposes specified in the law is read in view of the primary and plain meaning of its terms, and in the light of the evident intent and purpose of the secretary in prescribing it, its true interpretation is that such a sale or disposal shall not be made without taking the written agreement before or at the same time that the sale or disposal is made. It may be that under some circumstances the reduction of the agreement to writing within a few hours after the sale or disposal would constitute a fair compliance with the rule. It may be that it is not imperative that the agreement should be written and signed at the very instant of the sale. But it must be taken either before or at substantially the same time that the timber is sold or disposed of, and *dum fervet opus*, or its taking will not constitute a compliance with the law. A sale and delivery of the lumber without taking the written agreement until more than three months thereafter is not a substantial compliance with the act, and the court below fell into an error in charging the jury that they might so find. This error necessitates a reversal of the judgment.

This conclusion has not been reached without a consideration of the contention of the defendant that the errors in the trial of this case were not prejudicial to the government, and would not warrant a reversal of the judgment, for the reason that under the pleadings and evidence the plaintiff could not have recovered in any event. His theory is that the amended complaint, which is a complaint in replevin, superseded the original complaint, which was a complaint in conversion; that counsel for the government sought to recover at the trial upon the original complaint only; and that, as he was not entitled to recover in conversion, he was not entitled to recover at all. The amended complaint makes no reference to the original complaint. It is complete in itself, and it states a cause of action for the recovery of the possession of logs and lumber, or for their value, and nothing more. It does not allege or pray to recover damages for the taking

and conversion of the property. The questions whether or not the court properly allowed the filing of this complaint upon the motion of the plaintiff, and whether or not its various rulings against the defendant were just and lawful, are not here for our consideration, because the defendant has not sued out any writ of error or made any assignment of errors to enable us to review them. The amended complaint was filed under the order of the court. An amended complaint, which is complete in itself, and which does not refer to or adopt the original complaint as a part of it, entirely supersedes its predecessor, and becomes the sole statement of the cause of action. The original complaint becomes *functus officio* from the date of the filing of its successor. *Hawkins v. Massie*, 62 Mo. 552, 553; *State v. Simpkins*, 77 Iowa, 676, 678, 42 N. W. 516; *Cramer v. Mack* (C. C.) 12 Fed. 803, 804, 20 Blatchf. 479; *Washer v. Bullit Co.*, 110 U. S. 558, 562, 4 Sup. Ct. 249, 28 L. Ed. 249. When the amended complaint was filed, therefore, the original complaint for damages for conversion ceased to state any cause of action in this suit. The only cause of action stated then or thereafter was the cause of action in replevin set forth in the amended complaint. The first judgment in this action was reversed because a cause of action in replevin was tried on a complaint in conversion. If the government had recovered at the second trial, it must be conceded that its judgment would have been equally vulnerable, because it would have been the result of the trial of an action for conversion, and would have been a judgment for damages for conversion, when the only cause of action pleaded was in replevin. But it does not follow from the fact that a judgment against the defendant on the trial as it was actually conducted could not have been sustained on account of erroneous rulings against him that the government might not have recovered on the pleadings and the evidence if the error of which complaint has been made had not been committed. On the other hand, it may well be that, if the court had instructed the jury that, if the defendant had not complied with the rule in the removal and sale of the three lots of lumber which he delivered to Swope and to the owner of the Mabel-Grace mine, they would have found that he had not substantially complied with the rule of the secretary, and that the government was entitled to the possession of the timber, or of its proceeds, in the registry of the court, to the extent at least of its stumpage value, which was conceded to be \$1 per 1,000 feet. If they had come to that conclusion, a verdict to that effect would have been in accordance with the allegations and the proofs under the amended complaint. In this state of the case it cannot be said to be so clear that the government could not have recovered, in any event, under the pleadings and the proof that there is no doubt that the error of the court did not prejudice and could not have prejudiced the plaintiff, and for that reason it cannot be disregarded. The presumption always is that error produces prejudice. It is only when it appears so clear as to be beyond doubt that the error challenged did not prejudice and could not have prejudiced the complaining party that the rule that error without prejudice is no ground for reversal is applicable. *Railroad Co. v. Holloway*, 52 C. C. A. 260, 114 Fed. 458, 465; *Association v. Shryock*, 20 C. C. A. 3, 11, 73 Fed. 774, 781; *Railway Co. v. McClurg*, 8 C. C. A. 322,

325, 326, 59 Fed. 860, 863; *Deery v. Cray*, 5 Wall. 795, 807, 808, 18 L. Ed. 653; *Smith v. Shoemaker*, 17 Wall. 630, 639, 21 L. Ed. 717; *Moores v. Bank*, 104 U. S. 625, 630, 26 L. Ed. 870; *Gilmer v. Higley*, 110 U. S. 47, 50, 3 Sup. Ct. 471, 28 L. Ed. 62; *Railroad Co. v. O'Brien*, 119 U. S. 99, 103, 7 Sup. Ct. 118, 30 L. Ed. 299; *Mexia v. Oliver*, 148 U. S. 664, 673, 13 Sup. Ct. 754, 37 L. Ed. 602; *Railroad Co. v. O'Reilly*, 158 U. S. 334, 337, 15 Sup. Ct. 830, 39 L. Ed. 1006; *Peck v. Heurich*, 167 U. S. 624, 629, 17 Sup. Ct. 927, 42 L. Ed. 302.

Moreover, the judgment in this case leaves the real issue—the ownership of the proceeds of the lumber in the registry of the court—undetermined, and open to subsequent litigation. There have already been two mistrials of this case. This court has twice read the evidence which the respective parties have been able to produce relative to the character of the taking of the timber and the intention and purpose of the defendant, and, in view of the protracted litigation which this action is producing, it does not hesitate to express its opinion that the strong probabilities are that the ultimate result of this litigation, if continued, will be that the defendant will be found to be an innocent or unintentional trespasser, and entitled to all the proceeds of the lumber except its stumpage value of \$1 per 1,000 feet; and it suggests that if the parties, within 60 days after the mandate of this court is filed in the circuit court, shall stipulate that the United States may recover and be paid one-seventh, and the defendant, Gentry, may recover and be paid six-sevenths, of the proceeds of the lumber and logs in the registry of the court, without the taxation of any costs against either party, a judgment to that effect might be rendered upon this stipulation, and payments could be made accordingly. Such a course of proceeding would probably be more beneficial and less expensive to each of the parties to this litigation than farther trials of this action. If no such stipulation should be made, the case must be tried again.

As the pleadings now stand, the main issue is the ownership of the proceeds of the logs and lumber in the registry of the court. If the defendant was not a trespasser, he is entitled to this amount. If he was an innocent trespasser, he is probably entitled to about six-sevenths of it, while the government is entitled to one-seventh. If he was a willful trespasser, the United States is entitled to the entire fund. The judgment of the circuit court is reversed, and the case is remanded to the court below for further proceedings not inconsistent with the views expressed in this opinion.

CALDWELL, Circuit Judge (dissenting). The brief of the plaintiff in error does not comply in any respect with the requirements of rule 24 of this court (31 C. C. A. clxiv, 90 Fed. clxiv), which declares that errors not specified according to that rule “will be disregarded.” The technical character of the plaintiff’s case makes it one for the rigorous application of this rule. *Tubbs v. U. S.*, 44 C. C. A. 357, 105 Fed. 59; *City of Lincoln v. Sun Vapor Street Light Co.*, 19 U. S. App. 431, 8 C. C. A. 253, 59 Fed. 756; *Assurance Co. v. Polk*, 44 C. C. A. 104, 104 Fed. 649; *Oswego Tp. v. Travelers’ Ins. Co.*, 36 U. S. App. 13, 17 C. C. A. 77, 70 Fed. 225; *Van Gunden*

v. Iron Co., 8 U. S. App. 229, 3 C. C. A. 294, 296, 52 Fed. 838, 841; Grape Creek Coal Co. v. Farmers' Loan & Trust Co., 24 U. S. App. 38, 45, 12 C. C. A. 350, 353, 63 Fed. 891, 894; Doe's Ex'rs v. Mining Co., 44 U. S. App. 204, 214, 17 C. C. A. 190, 196, 70 Fed. 455, 461; Sovereign Camp v. Jackson, 38 C. C. A. 208, 97 Fed. 382. There is no reason why this rule, which we have applied in so many other cases, should not be applied to this case, but many reasons why it should be, and among them this one: it would have the effect to terminate this litigation. It is always allowable to oppose one technicality against another in order to put an end to litigation and promote the ends of justice.

If this rule is disregarded, and the merits gone into, it should be affirmed. Three small lots of lumber, amounting in the aggregate to a few hundred feet only, were delivered before the required written agreement was signed, but the sale was of so much lumber as the road overseer might need in making and repairing the roads in his district and of a small quantity a miner might need in his mining operations. When the defendant agreed to supply this lumber, no fixed quantity was or could be agreed upon that was to be determined by its application to the purposes and uses for which it was purchased. As soon as this amount was ascertained, the required written agreement was signed. This was not only a substantial, but a full, compliance with the rule of the secretary of the interior.

The verdict and judgment for the defendant ex necessitate disposed of the fund in court, because that fund was derived from the sale of property, which, though claimed by the United States at the inception of the suit, the jury found belonged to the defendant, and this finding necessarily entitled him to the fund. It is unreasonable to suppose that the owner of the property was not entitled to the proceeds of its sale. On motion the court must have ordered the proceeds of the sale paid to the owner of the property sold, in accordance with the uniform practice in such cases.

OLSEN v. NORTH PACIFIC LUMBER CO.

(Circuit Court of Appeals, Ninth Circuit. November 3, 1902.)

No. 726.

1. APPEAL—QUESTIONS REVIEWABLE ON SECOND APPEAL—LAW OF CASE.

Where the action of a trial court in a certain respect was specifically assigned as error in the appellate court, and was approved, at least by implication, the trial court is justified in following the same course on a second trial, and its action in so doing will not be again reviewed on a second appeal.

2. INJURY OF SERVANT—NOTICE OF STARTING MACHINERY—CUSTOMARY MANNER OF OPERATION.

One employed as off-bearer in a sawmill, his duty being to remove the hooks from the log or cant after it has been placed on the carriage, is not entitled to notice when the carriage is about to start, where it is uniformly started as soon as the hooks are removed, and he has been engaged at the work a sufficient length of time to know such fact.

3. INSTRUCTIONS—CONFORMITY TO ISSUES.

Where the complaint, in an action by a servant against the master to recover for an injury, alleged that such injury occurred through the

negligence of a fellow servant who was "habitually careless and negligent," which fact was known to defendant, and plaintiff introduced evidence of other alleged acts of negligence to sustain such allegation, it was not error to charge that to authorize a recovery the jury must find that the fellow servant was habitually careless, and that defendant knew or should have known such fact.

In Error to the Circuit Court of the United States for the District of Oregon.

John H. Mitchell, Watson & Beekman, and E. Mendenhall, for plaintiff in error.

Dolph, Mallory, Simon & Gearin and Rufus Mallory, for defendant in error.

Before GILBERT and MORROW, Circuit Judges, and HAWLEY, District Judge.

GILBERT, Circuit Judge. This is an action brought against the defendant in error by the plaintiff in error to recover damages for injuries which he sustained while in the employment of the defendant in error in its lumber mill. In the complaint the defendant in error is charged with negligence in retaining in its service one Riley Rearick, a fellow servant with the plaintiff in error. On the day when the accident occurred Rearick was the sawyer in charge of the "pony saw," and in connection therewith operated a steam derrick, by means of which logs or cants which had been sawed into proper shape were lifted from the floor of the mill and placed upon a saw carriage, where they were sawed into lumber. The derrick lifted the logs or cants by means of chains, on the ends of which were hooks which grappled them. The plaintiff in error assisted in this operation in the capacity of second off-bearer. It was his duty, after the cants had been lifted from the floor and placed upon the carriage preparatory to being sawed into lumber, to detach the hooks from the cants. When the cants were free it was the duty of Rearick to start the carriage toward the saw. On the occasion of the accident a cant had been placed on the carriage, and the plaintiff in error had removed the hooks from the cant, when Rearick caused the carriage to start; but the plaintiff in error at that time had his foot upon the saw carriage in such a position that in the forward movement of the carriage his foot was caught and crushed. In his complaint he alleges that Rearick was habitually careless and negligent in the performance of his duty as sawyer; that the defendant in error knew that fact, and negligently retained him in its employment; and that the defendant in error was further negligent in not giving proper instructions and in not providing suitable rules for the conduct of Rearick in the discharge of his duty, and for not exercising reasonable diligence and care in inquiring into and supervising his conduct as such sawyer in its employment. The case comes to this court for the second time, error being assigned to the ruling of the court upon the second trial in admitting certain evidence and in giving and refusing certain instructions to the jury.

It is contended that the court erred in permitting the jury to view the premises where the accident occurred, and to see the machinery of the mill in operation. It is not contended that the jury were in fact

misled, or that any experiment was made for their enlightenment, or that the machinery was operated in any manner different from the usual method, or that the jury saw anything other than the machinery as it was in its ordinary, continuous, daily operation; but authorities are cited to sustain the proposition that to permit the jury to view the operation of the machinery which occasioned the injury which is the subject of the action is to permit the jury to take evidence outside of court, and in the absence of parties and counsel, and is error, for the reason that it affords an opportunity to the party charged with negligence to so operate the machinery as to mislead the jury in his favor. We do not think that this question is now before us. The same error was assigned when the case was formerly in this court. *Olsen v. Lumber Co.*, 40 C. C. A. 427, 100 Fed. 384. It there appeared that not only had the court permitted the jury to view the machinery in operation, but it was shown that at the time when the view was had Rearick was in charge of the operation. In disposing of the error so assigned, this court, by McKenna, circuit justice, said: "We are not prepared to say that a view of a scene of an occurrence may not include machinery in operation. To permit the operation of the machinery, however, by the persons whose care or skill or duty is in question, is seriously disputable." We regard this utterance of the court as affirming the action of the trial court, and as expressing the opinion that it was not deemed error under the statute of Oregon to permit a view of the scene of an accident, together with a view of the operation of the machinery in connection with which the accident occurred. The question was directly presented to the court for adjudication, and, while the opinion of the court may not have been expressed in such clear and definite language as to constitute a precedent upon the point presented, it was, we think, sufficient for the guidance of the trial court upon the second trial. The circuit court upon the second trial (106 Fed. 298) so understood it, and upon deciding the motion for a new trial remarked: "Under no circumstances should I feel warranted, upon a second trial, in departing from the course pursued in the former trial, where that course had been a ground of objection on appeal, and in respect to which this court, if not sustained, had at least not been overruled nor criticised." We think the trial court was justified in regarding the decision of this court as settling the law of the case for its guidance upon a second trial, and, if so, it was not error to follow it, nor are we now required to enter upon a consideration of the grounds upon which the former opinion of this court was based.

The plaintiff in error earnestly contends that the defendant in error by its answer admits its negligence as it is charged in the complaint. The argument is that inasmuch as the complaint alleged that Rearick owed an active duty to give the plaintiff in error notice or warning before starting the saw carriage, and the defendant in error in its answer denied that Rearick owed such duty but at the same time admitted that the plaintiff in error was entitled to such notice, it by implication admitted that Rearick did not know that he owed plaintiff in error the duty of giving such notice, and that the defendant in error was aware of his want of such knowledge, "for

if it was not his duty he could not have supposed that it was, and the defendant in error could not have supposed that he did"; and it is contended that actual lack of knowledge on the part of Rearick that such was his duty, with notice thereof to the defendant in error, rendered Rearick incompetent and the defendant in error negligent. In brief, the argument is that because the defendant in error admitted that the plaintiff in error was entitled to notice, but denied that it was Rearick's duty to give such notice, it admitted by implication that Rearick was negligent, and that it knew that he was. The defect of the argument is that it construes the admission that the plaintiff in error was entitled to notice into an admission that it was Rearick's duty to give it. It does not follow, from the denial and the admission contained in the answer, that Rearick owed an active duty to give notice to the plaintiff in error of the starting of the carriage, that Rearick was negligent, or that the defendant in error knew that he was. The defendant in error in its defense to the action assumed the position that, although the plaintiff in error was entitled to notice of the starting of the carriage, Rearick owed no active duty to give the signal thereof. This cannot be construed as an admission that Rearick himself so understood his duty. Notwithstanding the admissions of its answer, the defendant in error would not have been precluded from showing, if it could have shown it, that Rearick did in fact habitually give notice to the off-bearer before starting the carriage. The admission of the answer, moreover, was followed by the averment that the method of the operation was itself notice to the off-bearer. It alleged that in the operation of the steam derrick and the saw carriage it was known and understood by all employed therein that the removal of the hooks from the cant was the signal to start the saw carriage forward; that it was notice to Rearick that the work of the off-bearer was completed, and it was notice to the off-bearer that the carriage would be started. There was evidence to sustain this allegation. There was some evidence contradicting it, it is true, but with the weight of the evidence we are not concerned. It would seem that the performance of a visible act, such as the removal of the hooks from the cant, leaving it free to move forward on the saw carriage, was, in the nature of things, a sufficient notice to the off-bearer. It was his duty to detach the hooks, and he had the best of opportunities for knowing that when that was done the carriage would be started. That was all the notice he or any one had ever had, and he must be held to have understood and accepted the risks of his employment in the manner in which the work was carried on. He had been employed for some months in and about the mill, but had been second off-bearer to Rearick's saw less than two days when the accident occurred. In that time, however, he had removed the hooks and had seen the saw carriage start from 12 to 20 times every hour. In view of these considerations, it must be held that there was no error in the refusal of the court to charge the jury that it was one of the duties of Rearick's position as sawyer to look out for the plaintiff in error, or to give him reasonable notice or warning before starting the moving of the saw carriage, or in instructing the jury, in substance, that there was nothing in the

case tending to show that it was Rearick's duty to give particular notice that the carriage was about to start. The question both of Rearick's duty in the premises and that of the defendant in error was under consideration when the case was first in this court. It was then held that the contention that the defendant in error should have directed Rearick, as sawyer, by rules and regulations, to observe care to the plaintiff in error, as off-bearer, could not be sustained. Said the court:

"To observe such care was essentially Rearick's duty, assumed in and by his employment. The business was not complex. There was no evidence that it was customary in sawmills to direct employes by special rules, and it could not be so held as a matter of law or submitted to the jury to decide without evidence. In complex employments like railroads rules have been held to be necessary. To require them in the simpler employments would only embarrass them, without useful effect."

This was said with reference to the evidence in the record, which showed then, as it does now, that no rules had been given Rearick by the defendant in error, and that no notice had been given the off-bearer or other employes of the starting of the saw carriage other than the removal of the hooks from the cant. The former decision of this court can be regarded in no other light than as holding that, although plaintiff in error was entitled to timely notice of the starting of the saw carriage, he was not entitled to notice other than that which was in fact given, and which was in accordance with the usual practice and method of operating the machinery in the mill. On the first trial of the case in the circuit court the jury was instructed upon this general subject in the following words:

"Something has been said as to the duty of the company to provide rules and regulations. There is no testimony proper for your consideration tending to show that in this particular case there was any duty devolved upon the mill company to provide rules and regulations as to how that saw should be started. The question of negligence in starting this saw, broadly, is submitted to you for your judgment as reasonable men. It is claimed that the nature of that employment is such that the employes were bound to take notice that when the cant was upon the carriage and the hooks were loosened the carriage was to start, and that the employes had notice of that from the manner in which the mill was being operated; that the mill was operated continuously in that way, from month to month and from year to year, and for at least two or three days' time during which this plaintiff operated there as second off-bearer; that he knew and saw that that was the way the mill was operated,—when the cant was on the carriage and the hooks were loosened the carriage started. There is nothing that justifies the claim that the mill company ought to have had rules; that they ought to have had some bell or signal, or method of notifying the party that the carriage was going to start, independently of the practice and of what was reasonable,—what a reasonably prudent man would have supposed, and what the course of business warranted him in knowing was the way in which the mill was operated. The duty was enjoined upon Riley Rearick, not by rules,—that makes no difference,—but the duty was enjoined upon him by law, to be careful. The mill company could not have made that duty any stronger than the law makes it. The law devolves upon him the duty to exercise reasonable care in his conduct in the operation of that saw, and what is reasonable care is a question for your determination. The law also enjoined upon the plaintiff himself the exercise of reasonable care. He was not to trust wholly to Riley Rearick. He must look out for himself. It was a hazardous employment he engaged upon, and he must exercise reasonable care himself, and the law enjoined that duty upon him. The law enjoined

upon each of these parties the duty to be careful in their respective employments; each to look out for himself, and each to look out for his co-employees as far as circumstances would permit,—as far as it could be reasonably expected of them under the circumstances; and, if the company had enjoined that duty by rules, it would have made the duty no more obligatory than the law makes it. It would not have strengthened the obligation which the law imposed upon these parties in that respect. So, then, gentlemen, if Riley Rearick was a careless man, and if the company knew that he was a careless man, either from general reputation or from notice of specific acts of carelessness coming to it, and if, being so careless, Riley Rearick was careless at the time of this accident, and the plaintiff himself was not careless at the time of the accident,—was in the exercise of due care,—if you find all these things concurring, then you may find a verdict for the plaintiff, and it will be your duty to do so. Otherwise your verdict should be for the defendant.”

That instruction was approved upon the former hearing in this court. It was again given upon the second trial. We think it covers the whole ground of the duty of the defendant in error and of Rearick toward the plaintiff in error in the premises.

Error is assigned to the following instruction:

“If you find that Riley Rearick was habitually negligent or was a careless man, and that the company had notice of that, or that the facts and circumstances are such that the company ought to have known it, and that the plaintiff did not know it (and there is no charge here that the plaintiff did), and that because of such negligence the plaintiff was injured, that negligence on his part contributing to the injury, your verdict should be for the plaintiff; otherwise it should be for the defendant.”

And to the instruction given when the jury came in for further instructions, as follows:

“If you find, first, that this accident is the result of his negligence; second, if you find that he was an habitually careless man; third, if you find that the defendant knew that he was an habitually careless man, or ought to have known it under the circumstances,—these three things concurring, your verdict should be for the plaintiff; otherwise it should be for the defendant.”

It is contended that there was error in these instructions, in that the court charged the jury that in order to find a verdict for the plaintiff they must find that Rearick was habitually careless, and in so doing required the jury to find more than the law required; that the use of the word “habitually” as it was employed by the court was erroneous; that to sustain his cause of action the plaintiff was required to prove no more than that Rearick was less careful than a person of ordinary care. In his complaint the plaintiff in error had alleged that Rearick was “habitually careless and negligent,” and that the defendant in error knew that fact. The instruction to the jury must be viewed in the light of the pleadings and the evidence upon which it was based. It was given with reference to four specified accidents occurring in a period of five years, concerning which the court reviewed the evidence and commented thereon, and concluded in these words: “These are the several incidents and accidents, if you may term them such, relied upon by the plaintiff as showing that Rearick was habitually careless and negligent.” The attention of the jury was thus directed to those incidents, and it was upon such evidence, if at all, that they were to find that Rearick was habitually careless. If counsel for the plaintiff in error considered that the charge was open to objection on account

of the use of the word "habitually," they should in their exception have directed the attention of the court thereto. Their exception to the charge was general. It did not advise the court of the nature of the objection. Undoubtedly the court would have corrected the language of the charge if it was calculated to mislead the jury and the court's attention had been directed specifically to it.

But there is another reason why we think the instruction was not reversible error. The trial court upon the motion for a new trial held that there was not sufficient evidence in the case to sustain a finding that the defendant in error knew that Rearick was careless. The court observed: "In this case the evidence in the particulars mentioned was so slight and unsatisfactory that it would have been the duty of the court to set aside the verdict if there had been one."

We find no error for which the judgment should be reversed. It is accordingly affirmed.

HECKMAN et al. v. SUTTER et al.

(Circuit Court of Appeals, Ninth Circuit. November 10, 1902.)

No. 792.

1. PUBLIC LANDS—ALASKAN TIDE LANDS—RIGHT OF OCCUPANCY.

Under the provision of section 3, Act May 17, 1884 (23 Stat. 24), providing a civil government for Alaska and creating a land district therein, that "the Indians or other persons in said district shall not be disturbed in the possession of any lands actually in their use or occupation or now claimed by them, but the terms under which such persons may acquire title to such lands is reserved for future legislation by congress," there having been no subsequent legislation which impairs its force, persons who, with their grantors, have since, prior to said act, occupied and used public lands adjacent to the coast, including a small strip of tide lands which they had cleared from stones and stumps to fit it for use in drawing seines for catching salmon, are entitled to be protected in the undisturbed use of such tide lands as against others who assert a common right to fish thereon.

Appeal from the District Court of the United States for Division No. 1 of the District of Alaska.

Chickering & Gregory and Oscar Foote, for appellants.

Winn & Shackelford, for appellees.

Before GILBERT, ROSS, and MORROW, Circuit Judges.

ROSS, Circuit Judge. The record in this case shows that for many years there was a small Indian settlement at a point on Tongass narrows, in Southeastern Alaska, where Ketchikan creek flows into the sea. The shore line there is in the form of a crescent, in front of which, at low tide, there is a sand and gravel beach alternately covered and uncovered by the flow and ebb of the tide. It was the custom of the Indians to fish for salmon at that place, as they were and still are found in great numbers at and about the point where the creek empties into the sea.

On the 17th day of May, 1884, congress passed an act entitled "An act providing a civil government for Alaska" (23 Stat. 24), by which

the land district of Alaska was created, and a United States land office established at Sitka. No provision was thereby made for the entry nor for the survey of any of the public lands of the territory other than mining claims, but it was, among other things, provided by section 8 of the act "that the Indians or other persons in said district shall not be disturbed in the possession of any lands actually in their use or occupation or now claimed by them, but the terms under which such persons may acquire title to such lands is reserved for future legislation by congress."

By an act approved March 3, 1891, entitled "An act to repeal timber-culture laws, and for other purposes" (26 Stat. 1095 [U. S. Comp. St. 1901, p. 1535]), congress provided, among other things, for the entry of lands in Alaska for town site purposes, and also "that any citizen of the United States twenty-one years of age, and any association of such citizens, and any corporation incorporated under the laws of the United States, or of any state or territory of the United States now authorized by law to hold lands in the territories, now or hereafter in possession of and occupying public lands in Alaska for the purpose of trade or manufactures, may purchase not exceeding one hundred and sixty acres, to be taken as near as practicable in a square form, of such land at two dollars and fifty cents per acre: provided, that in case more than one person, association or corporation shall claim the same tract of land, the person, association or corporation having the prior claim by reason of possession and continuous occupation shall be entitled to purchase the same; but the entry of no person, association, or corporation shall include improvements made by or in possession of another prior to the passage of this act."

In May, 1898, an act was passed by congress entitled "An act extending the homestead laws and providing for right of way for railroads in the district of Alaska, and for other purposes" (30 Stat. p. 409, [U. S. Comp. St. 1901, p. 1412]), the first section of which is as follows:

"That the homestead land laws of the United States and the rights incident thereto, including the right to enter surveyed or unsurveyed lands under provisions of law relating to the acquisition of title through soldiers' additional homestead rights are hereby extended to the district of Alaska, subject to such regulations as may be made by the secretary of the interior; and no indemnity, deficiency, or lieu lands pertaining to any land grant whatsoever originating outside of said district of Alaska shall be located within or taken from lands in said district: provided, that no entry shall be allowed extending more than eighty rods along the shore of any navigable water, and along such shore a space of at least eighty rods shall be reserved from entry between all such claims, and that nothing herein contained shall be so construed as to authorize entries to be made, or title to be acquired, to the shore of any navigable waters within said district: and it is further provided, that no homestead shall exceed eighty acres in extent."

Section 10 of this latter act is in part as follows:

"That any citizen of the United States twenty-one years of age, or any association of such citizens, or any corporation incorporated under the laws of the United States or of any state or territory now authorized by law to hold lands in the territories, hereafter in the possession of and occupying public lands in the district of Alaska in good faith for the purposes of trade, manufacture, or other productive industry, may each purchase one claim only not exceeding eighty acres of such land for any one person, association, or

corporation, at two dollars and fifty cents per acre, upon submission of proof that said area embraces improvements of the claimant and is needed in the prosecution of such trade, manufacture, or other productive industry, such tract of land not to include mineral or coal lands, and ingress and egress shall be reserved to the public on the waters of all streams, whether navigable or otherwise: provided, that no entry shall be allowed under this act on lands abutting on navigable water of more than eighty rods: provided, further, that there shall be reserved by the United States a space of eighty rods in width between tracts sold or entered under the provisions of this act on lands abutting on any navigable stream, inlet, gulf, bay, or seashore, and that the secretary of the interior may grant the use of such reserved lands abutting on the water front to any citizen or association of citizens, or to any incorporation incorporated under the laws of the United States or under the laws of any state or territory, for landings, and wharves, with the provision that the public shall have access to and proper use of such wharves, and landings, at reasonable rates of toll to be prescribed by said secretary, and a roadway sixty feet in width, parallel to the shore line as near as may be practicable, shall be reserved for the use of the public as a highway: provided, further, that in case more than one person, association, or corporation shall claim the same tract of land, the person, association, or corporation having the prior claim, by reason of actual possession and continued occupation in good faith, shall be entitled to purchase the same, but where several persons are or may be so possessed of parts of the tract applied for, the same shall be awarded to them according to their respective interests: provided, further, that all claims substantially square in form and lawfully initiated, prior to January twenty-first, eighteen hundred and ninety-eight, by survey or otherwise, under sections twelve and thirteen of the act approved March third, eighteen hundred and ninety-one, twenty-sixth Statutes at Large, chapter five hundred and sixty one [U. S. Comp. St. 1901, p. 1535], may be perfected and patented upon compliance with the provisions of said act, but subject to the requirements and provisions of this act, except as to area, but in no case shall such entry extend along the water front for more than one hundred and sixty rods: and provided, further, that the secretary of the interior shall reserve for the use of the natives of Alaska suitable tracts of land along the water front of any stream, inlet, bay, or sea shore for landing places for canoes and other craft used by such natives: provided, that the Annette, Pribilof Islands, and the islands leased or occupied for the propagation of foxes be excepted from the operation of this act."

The evidence tended to show, and the court below found, that an Indian named Charles Dickson "had settled upon the uplands near the mouth of Ketchikan creek, in the district of Alaska, at the tide waters of Tongass narrows, and had occupied and possessed certain lands at said place, on which were constructed the houses in which he and his family lived, and from which, during certain portions of the year, he carried on and conducted the business of fishing, in the manner and in accordance with the usual customs of the Indians; that by such occupation and use of said uplands the said Charles Dickson, on the 17th day of May, 1884, and for many years prior thereto, was and had been in the actual possession of the uplands in and about the mouth of said Ketchikan creek, as aforesaid." In 1888 the Indian Dickson executed to one Berry a quitclaim deed for a specifically described tract of 160 acres of land (including the house in which he lived, which was located a few hundred feet from Ketchikan creek, and but a few feet above high tide), fronting about a mile on the sea, and extending back therefrom about a quarter of a mile. It seems from the record that at the time of the execution of this deed Dickson was the only Indian (besides his wife and her daughter, who lived with him) then remaining at the place. The evidence concerning the question of

Dickson's possession is wholly indefinite and uncertain, and the court below so stated in its findings of fact; finding, however, that "he actually occupied a small tract of land, sufficient for the small houses in which he lived, and for the said fishing business, according to the primitive methods then employed by Indians." The evidence shows, and the court found, that the complainants below (appellees here) and their grantors (claiming under Berry) reduced to possession a considerable portion of the 160 acres described in the deed from Dickson to Berry, and "have used, occupied, and possessed all that portion thereof immediately about the mouth of the said Ketchikan creek bordering on Tongass narrows as aforesaid"; that for many years they have cleared the tide flats in and about the mouth of the creek of "stones, trees, stumps, and other débris that has drifted thereon each and every year before the beginning of the fishing season, and have prepared the said flats for fishing purposes, and during the fishing season have fished thereon, and on so much of said flats and the uplands as immediately surround the mouth of the said Ketchikan creek." It also appears that the complainants or their grantors erected a cannery and other improvements within 1,000 or 1,200 feet of the mouth of the creek, for the purpose of canning the salmon so caught, at a cost of about \$40,000. In catching the fish the complainants and their grantors used long seines, one end of which was fastened on the beach, and the other end carried out into the water so as to gather in the fish, and brought around to the beach also, thus necessitating the use of a portion of the tide flat in the operation. In July of the year 1900 the appellant the Alaska Packers' Association, which had a cannery within a few miles of this fishing ground, through some of its employés, who were also made defendants to the suit and are also appellants here, undertook, by means of larger seines and more of them, to commence to operate the same ground, and thus interfered with the possession and use of the tide flat in question then and theretofore enjoyed by the complainants, and prevented the complainants from using the same except when the defendants were not doing so. For those acts this suit was brought, the complainants seeking a decree restraining the defendants from entering upon the tide flat in question and waters in front thereof and taking fish therefrom, or from interfering with the alleged sole right of the complainants to use the said ground for fishing purposes. The court below having found possession by the complainants and their grantors of the upland adjoining the tide land adjacent to Ketchikan creek, and that 600 feet along the shore line of Tongass narrows (being 300 feet on each side of Ketchikan creek) "is a reasonable and proper space as a right of way for the said complainants from their said uplands to the deep water of the sea, and in setting their seines, and landing the same in their fishing business, and they are entitled to the sole and unrestrained use thereof for such purposes," rendered a decree adjudging that the complainants have the "use and occupancy of a highway from their upland holdings to the deep waters of the sea on Tongass narrows, in and about the mouth of Ketchikan creek, Alaska, of six hundred feet in width, being three hundred feet along the shore line of Tongass narrows on each side of Ketchikan creek," and enjoining the defendants "from in any manner

interfering with the complainants in their use of said right of way in going from their said upland holdings to the deep waters of the sea, and from interfering with the complainants or in any manner retarding or delaying them in the use of their seines and nets in spreading the same in the approaches to the deep water, and in drawing them in upon the said tide flats or their upland grounds, and that they, and each of them, are further restrained and enjoined from in any manner interfering, hindering, or delaying the complainants in the use and occupation of the said right of way for the purpose of pursuing their business of fishing, and going to and from their upland holdings to the deep water of the sea, and in so drawing and setting their seines without let, hindrance, or delay from any one over said right of way to their said upland holdings."

The ground upon which the court below gave its judgment may be seen from this excerpt from its opinion:

"We therefore have these propositions fairly well settled by the decisions: First, that the owner of the upland adjoining tide waters has littoral rights in the tide flats and the approaches to deep water that are valuable, and are property rights of which he cannot be deprived without due compensation; and, second, that he may construct wharves upon these tide flats running out from his uplands and in front thereof to deep water, unless he shall so construct them as to make his wharves a nuisance or a purpresture, and thereby to impede navigation and the exercise of those rights enjoyed in common by all people. It is also settled by high authority that the right to take fish in the waters of the sea, and even along the tide flats, is one common to all of the citizens. In what, then, are the property rights of the littoral owner greater or more sacred than the common right of all citizens to take fish?

"The right of the littoral owner to construct a wharf in front of his land is unquestioned, and it is clear that by such construction he deprives all others from the right to fish or in any other way to occupy the ground covered by his wharf. It is a matter of common information that driving piles and the construction of wharves thereon make the taking of fish beneath the wharf practically impossible. Are we to say, then, that the littoral owner's right of way across the tide flats to deep water permits him to occupy the tide flats to deep water, permits him to occupy the tide flats with his wharf whereby the right of fishery is made impossible, and yet by cleaning the flats from débris and other material that gathers thereon, and making them practical for the use of his nets and for the purpose of drawing them across the same, and landing the fish upon the uplands, that he acquires no higher or better right in this behalf than that which inures in common to all citizens to fish and navigate the seas and rivers of our country? It is believed that the principle which gives the littoral owner a right of way and the right to construct a wharf in front of his upland across the tide flats to the deep water may be also as clearly and reasonably applied to a right of way that shall permit the littoral owner to exercise certain possessory rights as a right of way to the deep water of the sea over the tide flats, and that he may acquire certain possessory rights of such right of way by cleaning away the débris and material deposited thereon and making it a clear and proper roadway from the deep water to the upland over which he may pass and repass with his nets in the act of fishing, unobstructed and uninterrupted by the nets or other appliances of those who have a common right to take fish in the waters of the seas and rivers of Alaska.

"It appears from the testimony in this case that the nets commonly used by fishermen in taking salmon are from a hundred to several hundreds of fathoms in length. A reasonable right of way to deep water for the purpose of setting and bringing in these nets to the high land would certainly seem to be not less in width than the shortest nets used, viz., six hundred feet, and that in going over this right of way to and from the upland the complainants should not be impeded or obstructed by any others who may have the common

rights of fishery at this point. That the possessory rights exercised over the right of way by the littoral owners in cleaning the débris, stumps, timber, brush, and stones therefrom gives the complainants as clear a right thereto as if the same was covered by a wharf. It is not intended that this right of way shall give the complainants exclusive rights of fishery upon the tide flats, but it is intended that in pursuing their vocation in taking fish from the deep water or along the tide flats, in going and returning to and from their upland holdings, they shall be in no wise interfered with or hindered by other fishermen. It seems clear to the court that to this extent the property rights of the littoral owners must be protected by law, and that, as in the case of the construction of a wharf, any interference with the right of the littoral owner or any interference with the littoral rights to the upland owner may be prevented by the restraining order and injunction issuing from this court."

We are of the opinion that the decree may and should be affirmed without reference to the theory upon which the court below proceeded. It is well settled that the United States government, while it holds country as a territory, has all the powers of national and municipal government, and may, if it sees fit to do so, grant rights in or titles to the tide lands of such territory as well as the public lands above high-water mark. The case of *Shiveley v. Bowlby*, 152 U. S. 1, 14 Sup. Ct. 548, 38 L. Ed. 331, leaves nothing more to be said on that question.

When, in 1884, congress undertook to provide a civil government for Alaska, it made of the territory a land district, located a United States land office at Sitka; put in full force and effect therein "the laws of the United States relating to mineral claims and the rights incident thereto," with certain conditions not necessary to be mentioned, withholding therefrom the application of "the general land laws of the United States," and expressly declaring "that the Indians or other persons in said district shall not be disturbed in the possession of any lands actually in their use or occupation or now claimed by them, but the terms under which such persons may acquire title to such lands is reserved for future legislation by congress." Section 8, Act May 17, 1884 (23 Stat. 24). There has been no "future legislation by congress" that applies to the present case, for this case involves no question of purchase or entry, and concerns only the right of occupancy and use of certain of the lands of the United States, including a small strip of tide land, as against a similarly asserted right on the part of third persons, which occupancy and use in no manner interferes with the right of navigation of the public waters. The prohibition contained in the act of 1884 against the disturbance of the use or possession of any Indian or other person of any land in Alaska claimed by them is sufficiently general and comprehensive to include tide lands as well as lands above high-water mark. Nor is it surprising that congress, in first dealing with the then sparsely settled country, was disposed to protect its few inhabitants in the possession of lands, of whatever character, by means of which they eked out their hard and precarious existence. The fact that at that time the Indians and other occupants of the country largely made their living by fishing was no doubt well known to the legislative branch of the government, as well as the fact that that business, if conducted on any substantial scale, necessitated the use of parts of the tide flats in the putting out and hauling in of the

necessary seines. Congress saw proper to protect by its act of 1884 the possession and use by these Indians and other persons of any and all lands in Alaska against intrusion by third persons, and so far has never deemed it wise to otherwise provide. That legislation was sufficient authority, in our opinion, for the decree of the court below securing the complainants in the use and possession of land which the evidence shows and the court found was held and maintained at the time of their disturbance therein by the defendants, and for years theretofore had been so held and maintained.

The judgment is affirmed.

STEWART v. UNITED STATES.

(Circuit Court of Appeals, Eighth Circuit. November 3, 1902.)

No. 1,717.

1. CRIMINAL LAW—HABEAS CORPUS—JURISDICTION OF COURTS—REMOVAL OF PRISONER—SUFFICIENCY OF INDICTMENT.

Where a prisoner arrested under a warrant based on an indictment in a foreign district is committed for removal to the foreign district solely on the strength of the indictment, the circuit or district court of the district in which he is arrested has authority on habeas corpus to examine the indictment, and to release the prisoner in case it is fundamentally defective.

2. SAME—USING THE MAILS TO DEFRAUD—INDICTMENT.

An indictment under Rev. St. § 5480 [U. S. Comp. St. 1901, p. 3696], punishing the use of the mails with intent to defraud, must allege that defendants had devised a scheme to defraud, which was to be effected by opening or intending to open correspondence with some person by means of the use of the mails, or by inciting such person to open communication with defendants, or some of them, and that, in the execution of the scheme, defendants either placed a letter in a post office, or took one therefrom.

3. SAME.

Another requisite of such an indictment is that the fraudulent scheme must be described with sufficient certainty to inform defendants with reasonable certainty of the nature of the evidence to establish the scheme which will be adduced at the trial.

4. SAME.

An indictment under Rev. St. § 5480 [U. S. Comp. St. 1901, p. 3696], found in the district of Kansas, after alleging that defendants' fraudulent scheme was to be effected by inciting divers persons to open correspondence with them, averred that a third person named deposited in a post office in Kansas a letter addressed to one of the defendants at a city in Missouri, but without alleging that it was taken from the mails by the addressee or any of the other defendants. *Held*, that if the court could assume, in the absence of an express averment to that effect, that the letter was taken from the mails by the addressee or by the other defendants, it would appear that the offense was committed in Missouri.

5. SAME.

A count in an indictment under Rev. St. § 5480 [U. S. Comp. St. 1901, p. 3696], alleged that the fraudulent scheme devised by defendants was to induce, by the use of the mails, persons to come to a designated city in Missouri, in the expectation of there defrauding them by various artifices not then conceived. It showed that the mails were not the sole means defendants intended to employ to induce persons to come to such city. It also showed that the letter written by one of the defendants

to a third person, on which the count was founded, was deposited in the mail long after the person to whom the letter was addressed had been induced to go to the designated city by oral representations made to him by a party to the scheme, and had been induced to part with his money by the various fraudulent pretenses and artifices there resorted to. *Held*, that the indictment did not clearly show that the letter in question was deposited in the mail in execution of the alleged scheme to defraud, but rather disclosed that it was so deposited after the scheme so described had been executed. *Held*, further, that the indictment contained so many redundant and immaterial allegations as to render it almost unintelligible, and that it was so far lacking in certainty of averment that it ought to be quashed on a motion to that effect.

Appeal from the District Court of the United States for the Western District of Missouri.

This was a proceeding by habeas corpus. An indictment was returned against J. P. Stewart, the appellant, and against Robert Boatright, E. E. Ellis, L. B. Gillett, and G. O. Stansbury, on November 15, 1901, in the district court of the United States for the district of Kansas, Third division, charging them with an offense under section 5480 of the Revised Statutes of the United States [U. S. Comp. St. 1901, p. 3696]. Stewart, the appellant, being a resident of the Western district of Missouri, a complaint was filed by A. S. Van Valkenburgh, assistant United States attorney for the Western district of Missouri, before John M. Nuckols, United States commissioner within and for said district. Such complaint was made pursuant to the provisions of section 1014 of the Revised Statutes of the United States [U. S. Comp. St. 1901, p. 716]. A warrant was issued by the commissioner, under which Stewart was arrested and brought before him for a hearing, at which the commissioner held the defendant to bail in the sum of \$2,000, to appear on the first day of the next term of the district court of the United States for the Third division of the district of Kansas. The defendant Stewart failed to give the required bond, whereupon the commissioner committed him to the custody of the marshal for the Western district of Missouri until a warrant of removal should be issued by the United States district judge for said Western district of Missouri pursuant to section 1014 of the Revised Statutes [U. S. Comp. St. 1901, p. 716]. The appellant then applied for a writ of habeas corpus to the district court of the United States for the Western district of Missouri, and such a writ having been issued, and a return made thereto by the marshal who held the accused in custody, the district court ordered the writ to be discharged, and remanded the appellant to the custody of the marshal. The present appeal is from such order.

The question considered below, and for determination by this court, is whether the indictment which was returned and filed in the United States district court for the district of Kansas stated an offense under section 5480 of the Revised Statutes [U. S. Comp. St. 1901, p. 3696]. As the indictment is quite lengthy and involved, and contains many immaterial allegations, the most material parts thereof, only, will be stated in *hæc verba*. Omitting the introductory part, the indictment charged that Stewart, Boatright, Gillett, and Stansbury "on or about the second day of August in the year * * * 1901 at the Third division of the district of Kansas * * * having before that time knowingly, wrongfully and unlawfully devised a scheme and artifice to defraud one J. M. Davis, of Bourbon county, Kansas, and certain other persons whose names are to the grand jurors * * * unknown of large sums of money, to wit: about \$6,500, and other large sums of money from divers other persons, which said sums, and the names of such other persons being to the grand jurors * * * unknown and which said scheme and artifice to defraud was to be effected by opening and intending to open correspondence and communication with the said J. M. Davis and one Joseph Cooke, both of Bourbon county, Kansas, and divers other persons whose names and addresses are to the grand jurors aforesaid unknown and by inciting and intending to incite and causing and intending to cause the said J. M. Davis and the said Joseph Cooke and divers other persons * * * to open correspondence and communication with the said Robert Boatright, J. P. Stew-

art. E. E. Ellis, L. B. Gillett and G. O. Stansbury * * * and other persons to the grand jurors unknown, by means of the post-office establishment of the United States which said use and misuse of the post-office establishment of the United States was a part of said scheme and artifice to defraud and which said scheme and artifice to defraud was and is in substance and effect as follows, to wit: that Webb City, Jasper county, Mo., is the headquarters for the defendants [above named] and a large number of other persons associated with said defendants, the names of such other persons being to the grand jurors aforesaid unknown, all of whom are associated together and have for a common purpose and design the promotion of pretended and fraudulent foot races, that among said defendants above named and their associates, with headquarters at Webb City, Mo., as aforesaid, there are a large number of persons who are known as professional foot racers, to wit: L. B. Gillett, G. O. Stansbury and others, the names of which said other professional foot racers being to the grand jurors aforesaid unknown, that it is the purpose and object of the said defendants above named together with the other persons associated with said defendants, by false, fictitious and fraudulent means and practices to induce divers and sundry persons throughout the United States of America and territories to visit Webb City, Jasper county, Mo., to wit, by opening and intending to [open] correspondence and communication with such divers and sundry persons and by inciting and causing such divers and sundry persons to open correspondence and communication with said defendants and their associates by means of the post-office establishment of the United States and otherwise and by inducing and procuring said defendants L. B. Gillett and G. O. Stansbury and others of the associates of said defendants to go to various places in the United States and territories and become acquainted with divers and sundry persons and by false and fraudulent statements and representations made to such persons induce and procure such divers and sundry persons to visit Webb City * * * with the end in view of causing such person so induced to visit Webb City, Mo., to wager and advance to be wagered large sums of money and other property on the result of pretended and fraudulent foot races between certain persons above mentioned, to the end * * * that such persons so induced to visit Webb City, Mo., will wager and advance to be wagered their said money and property * * * upon the result of said pretended and fraudulent foot race, the result of which said races having already been prearranged and agreed upon between the said defendants and their associates aforesaid and by means of which said [prearranged] and agreement between said defendants and their associates aforesaid, then, there and thereby intending to defraud said divers and sundry persons whom they had theretofore induced to visit Webb City, Mo.; that the said defendants and their associates at all times represented themselves to be business men and merchants at Webb City, Mo., and men of reliability * * * of good credit and of good standing in the community * * * and honest in all [the] dealings, and able, willing and ready to meet any and all obligations incurred by them or any of them, when in truth and in fact the said defendants and their associates were associated together for the purpose and object of defrauding various persons whom they might induce or cause * * * to visit Webb City * * * for the purpose aforesaid, and in truth and in fact it was not the intention of the said defendants nor any of their associates to deal honestly with any person so induced to visit Webb City, Mo., * * * and in truth and in fact the said defendants were not honest, respectable nor reliable men, nor were they men of good standing in the community in which they lived nor were they willing or ready to meet their business obligations, but in truth and in fact the said defendants and their associates were gamblers, confidence men and swindlers, as they the said * * * defendants then and there well knew." After alleging the scheme to defraud in the manner aforesaid, the pleader next alleged in great detail what was done in the execution of the scheme. These allegations may be stated, in substance, and with greater brevity than in the indictment, as follows: The defendant Gillett went to Bronson, Kan., where Davis resided. He there made the acquaintance of Davis, and told him that he (Gillett) was a professional foot racer; that he knew a man by the name of Ellis, at Webb City, Missouri, who would bet a

large sum of money on a foot racer by the name of Stansbury, and another man, by the name of Boatright, who would wager a large sum of money that he (Gillett) could beat Stansbury in a foot race; that Ellis would not bet with Boatright, because the latter knew how fast Stansbury could run, but that, if a stranger like Davis came along, Ellis could be induced to bet with him. He accordingly proposed that Davis should go to Webb City and make a bet with Ellis, telling him that Boatright would furnish the money, and allow him (Davis) 25 per cent. of what was won. Davis accordingly went to Webb City, and was there introduced by Gillett to Boatright and to the appellant Stewart, the latter of whom represented to Davis that Boatright was a reputable business man. Davis thereupon made a bet with Ellis, in the sum of \$4,400, that Gillett could beat Stansbury; receiving the money wherewith to make the bet from Boatright, who was made stakeholder, and received the money back from Davis as soon as it was loaned. Thereupon Boatright represented to Davis that he had no more money to wager with Ellis upon the result of the intended foot race, but stated to Davis that, if he (Davis) would loan him \$5,000, he (Boatright) would wager that further sum with Ellis upon the result of the proposed race. Davis agreed to loan the last-mentioned sum of money to Boatright on condition that the sum loaned should be refunded before the race was run. He accordingly drew a sight draft in the sum of \$5,000 on the Bank of Bronson, Kan., where he had money on deposit, which draft was made payable to the order of the appellant, Stewart, who was cashier of a bank at Webb City. Stewart sent the draft to Bronson, Kan., by mail, in a letter addressed to the bank of Bronson, Kan., which requested that bank to forward the proceeds of the draft to Stewart. Boatright then pretended to make an additional bet with Ellis in the sum of \$5,000 with the money which he had borrowed from Davis. The day appointed for the race arrived before Boatright had refunded the amount of the loan, and, when the race was being run, Gillett, in the course of the race, fell down, and claimed to have sustained some injury. Thereupon it was agreed that the race should be run over as soon as Gillett recovered from the injuries which he pretended to have sustained. Gillett fell down in the course of the race, and the agreement postponing the race was made to prevent Davis from stopping payment of the draft which he had drawn on the Bank of Bronson. Joseph Cooke, who was president of the Bank of Bronson, on the receipt of the letter containing the Davis draft, wrote a letter to the appellant Stewart, under date of August 5, 1901, wherein, in payment for the sight draft drawn by Davis, he inclosed a draft on the American National Bank of Kansas City in the sum of \$5,000, which latter draft was made payable to the order of J. P. Stewart, Cashier. This letter so written by Cooke to Stewart, and deposited in the mail at Bronson, Kan., is one of the letters counted upon in the indictment as constituting an offense under section 5480 [U. S. Comp. St. 1901, p. 3696]. The second count of the indictment was, in substance, the same as the first, except that it counted upon a different letter as constituting the offense; the same being a letter deposited by Davis in the mail at Bronson, Kan., on August 5, 1901, addressed to Boatright, at Webb City, Mo., whereby Davis transmitted a draft of \$1,500 to Boatright, and told him to get a like amount from Ellis and deposit it in the bank. The indictment also contained a third count, substantially like the first, except that it counted upon another letter, written by Gillett to Davis, and deposited in the mail at Neal, Kan., on August 20, 1901, after the race had been postponed, wherein Gillett informed Davis that the doctor advised him that his foot, which had been injured, was healing as fast as it possibly could heal, and that he would be able to get his shoe on his foot in a week or ten days.

Edgar E. Bryant (H. C. Mechem and W. R. Robertson, on the brief), for appellant.

John S. Dean, U. S. Atty.

Before SANBORN and THAYER, Circuit Judges, and LOCHREN, District Judge.

THAYER, Circuit Judge, after stating the case as above, delivered the opinion of the court.

The consensus of judicial opinion seems to be that when a United States commissioner, proceeding under section 1014 of the Revised Statutes of the United States [U. S. Comp. St. 1901, p. 716], commits a prisoner for removal to a foreign district where the prisoner has been indicted, the prisoner may apply to the federal circuit or district court of the district where he has been arrested for a writ of habeas corpus, and if, on the return to such writ, it appears that he was committed for removal solely on the strength of an indictment found in the foreign district, and without other evidence that a crime has been committed, he may be discharged, provided it appears that the indictment, on the strength of which the commitment was obtained, is essentially and fundamentally defective. A federal judge to whom an application for a warrant of removal is made under section 1014 [U. S. Comp. St. 1901, p. 716], it has been said, "misconceives his duty, and fails to protect the liberty of the citizen," if he issues the warrant solely on the strength of an indictment found in the foreign district, which does not substantially state an offense under federal laws. These propositions have been decided frequently at nisi prius, beginning with the case *In re Buell*, 3 Dill. 116, 120, 121, Fed. Cas. No. 2,102. See, also, *In re Terrell* (C. C.) 51 Fed. 213; *U. S. v. Brawner* (D. C.) 7 Fed. 86; *In re James* (C. C.) 18 Fed. 853; *In re Dana* (D. C.) 68 Fed. 886. The practice of issuing a writ of habeas corpus in such cases for the purpose of inquiring into the validity of an indictment on the strength of which a person has been committed to await the issuance of a warrant of removal under section 1014 of the Revised Statutes [U. S. Comp. St. 1901, p. 716] was also sanctioned and approved by the supreme court of the United States in *Re Palliser*, 136 U. S. 257, 10 Sup. Ct. 1034, 34 L. Ed. 514, and in *Horner v. U. S.*, 143 U. S. 207, 12 Sup. Ct. 407, 36 L. Ed. 126.

In the present case it appears that Stewart, the appellant, was committed for removal solely on the strength of an indictment found in the district court of the United States for the district of Kansas, Third division, without other evidence of his guilt than the allegations contained in the indictment. We proceed to inquire, therefore, whether the indictment was sufficient to justify a warrant of removal. If it was insufficient, the appellant was entitled to be discharged from arrest.

In framing the indictment in question to meet the requirements of section 5480 [U. S. Comp. St. 1901, p. 3696], under which it was drawn, it was incumbent upon the pleader to allege that the defendants had devised a scheme or artifice to defraud, which was to be effected by opening or intending to open correspondence with some other person by means of the United States mail, or by inciting such other person to open communication with the defendants, or some one of them, and that, in the execution of the scheme so devised, the defendants either placed a letter in a post office of the United States, or took one therefrom. The offense denounced by section 5480 [U. S. Comp. St. 1901, p. 3696] consists either in the placing

of a letter in a United States post office, or in the receiving of one therefrom by a person who is a party to such a scheme or artifice to defraud, as the statute describes. *Stokes v. U. S.*, 157 U. S. 187, 15 Sup. Ct. 617, 39 L. Ed. 667. It was also incumbent upon the pleader to describe the scheme or artifice to defraud which had been devised, with such certainty as would clearly inform the defendants of the nature of the evidence to prove the existence of the scheme to defraud, with which they would be confronted at the trial.

It is to be observed, in the first place, that in so far as the letter mentioned in the first count of the indictment is concerned, namely, the one written by Joseph Cooke, and deposited in the post office at Bronson, Kan., on August 5, 1901, it is not alleged anywhere in the indictment that it was taken from the mail by Stewart or by any of the other defendants; and even if it was so taken from a post office, or if we assume, in the absence of a positive averment to that effect, that it was so taken, the act of receiving it from the post office, which is the act constituting the offense, must have been committed at Webb City, Mo., to which place it was addressed, and not within the district of Kansas, where the offense is laid. The deposit of this letter in the mail by Cooke at Bronson, Kan., did not constitute an offense, because Cooke was not a party to the alleged scheme or artifice to defraud. An offense could only have been committed, as respects this letter, by its being taken from the mail at Webb City by one of the defendants, and the fact that it was so taken is not averred. Besides, if the fact had been averred, this count of the indictment would have shown an offense committed within the Western district of Missouri, rather than in the district of Kansas, where the indictment was found.

The same observations may be made with respect to the letter described in the second count of the indictment, namely, the letter written by Davis, and addressed to Boatright, at Webb City, Mo., under date of August 5, 1901, which was deposited in the mail at Blue Mound, Kan., and is the letter upon which the second count of the indictment is founded. This letter was not deposited in the mail by either of the defendants, nor is it alleged that it was taken from the post office by either of the defendants; and if it be assumed, in the absence of an express averment to that effect, that it was received by Boatright from the post office at Webb City, Mo., then the act constituting the offense was committed within the Western district of Missouri. It is clear, we think, that neither the first nor the second count of the indictment, for the reasons above indicated, alleged an offense against the laws of the United States committed within the district of Kansas.

This leaves for consideration the single question whether the third count of the indictment sufficiently states an offense to warrant the removal of the prisoner to a foreign district. The count in question is based on a letter written by one of the defendants, L. B. Gillett, on August 28, 1901, at Neal, Kan., and deposited in the post office at that place, and addressed to Davis at Bronson, Kan., which letter advised Davis that Gillett's foot was healing as fast as it could. It is noticeable that the act constituting the offense, namely, the deposit

of this letter in the post office, though committed in Kansas, was not done by the appellant, Stewart, unless the act of one of the defendants named in the indictment be regarded as the individual act of each. We shall assume, without deciding, that the averment of the indictment showing that the defendants concocted a scheme to defraud is sufficient to establish that the act of either one of the defendants, if done in execution of the scheme, was the act of all, although there is no express allegation in the indictment of a conspiracy among the defendants to commit an offense under section 5480 [U. S. Comp. St. 1901, p. 3696]. Waiving this defect, if it be a defect, it is more important to consider what the scheme or artifice to defraud was, as it is described in the indictment. Certain foot racers, it seems, whose headquarters were at Webb City, Mo., formed a scheme to induce divers and sundry persons to visit Webb City, by entering into communication with them by means of the post-office establishment of the United States. The indictment then avers that the object which they had in view in inducing persons to come to Webb City was to influence them after their arrival to wager, or advance money to be wagered, on "pretended and fraudulent foot races." It is manifest, therefore, that the fraud which was actually practiced consisted of representations made to persons who came to Webb City, and of artifices that were resorted to after their arrival to induce them to wager money, or advance money to be wagered, on fraudulent foot races; but the indictment, in that part which describes the scheme, wholly fails to aver what such representations and artifices were, or were intended to be, when the scheme was formed. Nor does it aver in what respect the foot races were fraudulent, except, in a general way, that they were "prearranged and agreed upon." The sum and substance of the scheme, as alleged in the indictment, is this: That persons were to be induced to come to Webb City, by the use of the mails, in the hope and expectation that after they arrived they could be fleeced by various fraudulent artifices not then conceived or formulated, but which might afterwards be devised to accomplish that end. It is furthermore noteworthy that, as the scheme is described in the indictment, the mails were not the sole means which the defendants intended to employ to induce persons to come to Webb City, for the indictment expressly avers that some of the defendants, namely, Gillett and Stansbury, were to go in person to various places and make the acquaintance of persons who were supposed to be gullible, and, by such fraudulent representations as they saw fit to make, induce them to go to Webb City.

Another observation to be made concerning the indictment is this: That while the fraudulent scheme, as described, was one whereby the mails were to be employed to induce persons to come to Webb City, to be afterwards defrauded, yet the letter which was deposited in the mails by Gillett, on which the third count is founded, does not seem to have been written to accomplish any such purpose, and for that reason it can hardly be said to have been deposited in the mail in execution of such a scheme as the indictment describes. It was written, as it seems, long after Davis had been induced to go to Webb City and after he had wagered his money and sustained all

the loss that he could possibly sustain by reason of the alleged fraudulent scheme.

It should be further observed, concerning the indictment as a whole, that it is needlessly long and involved, and that it contains many redundant and immaterial allegations, which defects, when taken together, render it difficult to construe, and almost unintelligible. If it be an offense under section 5480 [U. S. Comp. St. 1901, p. 3696] to use the mails to induce persons to come to a certain place for the purpose of defrauding them by tricks and artifices to be devised after their arrival, then the indictment now under consideration might and should have been made much shorter, more explicit, and more intelligible. We are of opinion that it lacks that certainty of averment which should be found in an indictment or information, and that for this reason, if for no other, it ought to be quashed on a motion to that effect. The result is that the order of the district court discharging the writ of habeas corpus is reversed and the cause is remanded to the lower court, with instructions to discharge the appellant.

MacGINNISS v. BOSTON & M. CONSOL. COPPER & SILVER MIN. CO.

(Circuit Court of Appeals, Ninth Circuit. October 6, 1902.)

No. 812.

1. REMOVAL OF CAUSES—SEPARABLE CONTROVERSY—SUIT BY STOCKHOLDER.

A suit in a state court by a stockholder of a domestic corporation, who is a citizen of the same state, against such corporation and a foreign corporation, the purpose of which is to enjoin the latter from obtaining and exercising control over the property, business, and corporate stock of the domestic corporation, does not involve a separate controversy between complainant and the foreign corporation, which gives the latter the right of removal. Such suit is necessarily based entirely upon the rights of complainant as a stockholder of the domestic corporation, and to every controversy between him and the foreign corporation involving such rights, the domestic corporation is a necessary party.

2. SAME—INCIDENTAL RELIEF AGAINST ONE DEFENDANT.

Where the relief sought against one of several defendants is merely incidental to the principal purpose of the suit, the fact that such incidental relief pertains to one only of the defendants does not make it a separable controversy so as to give such defendant the right of removal.

3. SAME—PRAYER FOR RELIEF NOT SUPPORTED BY AVERMENTS OF BILL.

In order to show the existence of a controversy, facts must be alleged which present a question for the determination of the court, and a prayer, *inter alia*, for relief against one of several defendants, does not create a separate controversy with such defendant, where there are no averments in the bill upon which such relief could be based.

4. SAME—ARRANGEMENT OF PARTIES—SUIT BY STOCKHOLDER.

In a suit by a stockholder in a domestic corporation against such corporation and a foreign corporation to enjoin the latter from obtaining and exercising control over the property and business of the former, which the bill alleges is about to be accomplished through an illegal conspiracy between the defendants, the domestic corporation is not a

¶ 1. Separable controversy as ground for removal of cause to federal court, see notes to *Robbins v. Ellenbogen*, 18 C. C. A. 86; *Mecke v. Mineral Co.*, 35 C. C. A. 155.

party in the same interest with complainant, and cannot be aligned with him for the purpose of giving the foreign corporation the right of removal on the ground of diversity of citizenship.

Appeal from the Circuit Court of the United States for the District of Montana.

This suit was removed to the circuit court of the United States for the district of Montana from the district court of the Second judicial district of that state for the county of Silver Bow, by the Amalgamated Copper Company, upon the ground that as to that corporation the case presents a separable controversy. The suit is brought by the appellant, John MacGinniss, against the Boston & Montana Consolidated Silver Mining Company, a corporation, hereinafter designated as the Boston & Montana Company, and the Amalgamated Copper Company, a corporation, and certain named persons who were the officers of said respective corporations. The complaint alleged, in substance, that the Boston & Montana Company is a corporation organized, prior to the year 1898, under the laws of Montana, for the purpose of purchasing, acquiring, holding, mining, and operating mines and mining claims in said state, and owning and operating smelters and reduction works in connection therewith, and purchasing and owning such real and personal property as might be necessary to carry on its said business; that its capital stock is 150,000 shares, of the par value of \$25. per share; that it has acquired valuable mines and has engaged in profitable mining business and has paid large dividends to its stockholders; that its officers and directors claim and assert that the property, business, franchises, and rights of the said corporation are of the value of more than \$56,000,000; that the appellant, the plaintiff in the suit, is a citizen and resident of Montana, and is the owner of 100 shares of the stock of said corporation, and that he brings the suit in his own behalf and for the benefit of all other stockholders who may desire to join therein; that during the year 1898 the directors and officers of said corporation, without the consent of the appellant and without right, entered into an agreement with a large number of said stockholders whereby they obtained their consent to the sale, transfer, and assignment of all the property and rights of the corporation to a corporation of like name organized and existing under the laws of the state of New York, but such transfer and delivery of possession was without right, and in violation of the rights of the stockholders who had not consented thereto, one of whom was the appellant; that the appellant purchased his stock because of its known value, and because the corporation was a Montana company, subject to the laws of that state; that in June, 1898, the appellant and James Forrester, who also owned 100 shares of such stock, commenced an action in the district court of the Second judicial district of the state of Montana in and for Silver Bow county, on their own behalf and for the benefit of other stockholders, against the said Boston & Montana Company, the New York corporation, and the officers and directors of the same, and certain other persons, as defendants, for the purpose of having said transfer and conveyance to the New York corporation declared null and void, and enjoining the latter from carrying on mining operations in said mining property, and to have a receiver appointed to take charge of said property and to compel the return of all thereof to the Montana corporation of that name; that an injunction was granted in said case, and afterwards a receiver was appointed, who took charge of the property, and upon a hearing in the supreme court of Montana, upon an appeal from the order of the district court granting the injunction, it was held that the acts complained of by the plaintiffs in said action against the corporation, its officers and trustees, were ultra vires, and it was adjudged that the Montana company had no right or authority, without the consent of all its stockholders, to transfer or dispose of all its property or assets; that thereafter all the property belonging to the Boston & Montana Company in the state of Montana was taken possession of by it, and that it thereafter continued to mine its property and conduct its business as before and to pay large dividends to its stockholders; that the purpose of the transfer to the New York corporation was to terminate.

the existence of the Montana corporation, and to take away the jurisdiction of the courts of Montana, for the reason that the laws of that state were more favorable to mineral stockholders than were the laws of New York; that thereafter, for the purpose of taking the management of said property and business away from the jurisdiction of the laws and courts of Montana, the officers and a majority of the stockholders agreed together and interested themselves in procuring legislation to that end, and procured the passage of an act of the legislative assembly of the state of Montana for the purpose of enabling a transfer and giving such control and management without the consent of all the stockholders, and thereafter, and fearful that such act might be held unconstitutional, and seeking to evade the decision of the supreme court above referred to, the directors of the corporation, acting with certain other persons, and under an agreement with a majority of the stockholders, and under an agreement with certain stockholders and officers of certain other Montana corporations, organized the defendant the Amalgamated Copper Company under and by virtue of the laws of the state of New Jersey, with its principal office and place of business in that state, for the purpose of creating a trust, and controlling the production and sale of copper and other metals, and that pursuant to that purpose the Amalgamated Copper Company has purchased, and now owns and controls, either directly or through the agency of trustees, all the shares of the capital stock, except organizers' shares, in the following corporations organized under the laws of Montana, to wit, the Washoe Copper Mining Company, the Colorado Smelting & Mining Company, the Big Black Foot Milling Company, the Diamond Coal & Coke Company, the Parrot Silver & Copper Company, the Anaconda Copper Mining Company, and 10,000 shares of the capital stock of the defendant the Boston & Montana Company, and more than 90 per cent. of the capital stock of the Butte & Boston Consolidated Mining Company, a corporation organized under the laws of the state of New York, and owning numerous mines and a smelter in the state of Montana, and a majority of the capital stock of the Hennessey Mercantile Company, a corporation organized under the laws of the state of Montana, and owning valuable property therein, and carrying on a mercantile business therein; that the Amalgamated Copper Company was organized with a capital stock of \$75,000,000, consisting of 750,000 shares, of the par value of \$100 each; that thereafter it increased its capital stock to \$155,000,000, the purpose of which increase was to enable it to trade shares for acquiring the control of a majority of the shares of the capital stock of the Boston & Montana Company and of the Butte & Boston Consolidated Mining Company, above mentioned, and to control and direct the management thereof, and to appoint or elect officers and agents who would obey the orders and directions of said Amalgamated Copper Company. The appellant alleged, upon information and belief, that the directors of the Boston & Montana Company have agreed together and with the holders of a majority of the capital stock of that corporation to transfer, assign, and set over unto the Amalgamated Copper Company three-fourths of the capital stock of the Boston & Montana Company, for the purpose of giving the control, management, and direction of its business to the said Amalgamated Copper Company, and the latter corporation has, in pursuance of said agreement, acquired and now holds more than 90 per cent. of said capital stock of the Boston & Montana Company, and the directors of said latter company have agreed and bound themselves to act with reference to all matters pertaining to their corporation, its property and its business, as the Amalgamated Copper Company shall order and direct, and that the Amalgamated Copper Company procured said shares of stock of the Boston & Montana Company by exchanging with the officers and shareholders thereof at the rate of four shares of the stock of the Amalgamated Copper Company for one share of stock in the other company. And the appellant further alleged that said Amalgamated Copper Company has not complied with the laws of the state of Montana to enable foreign corporations to do business in that state, but that it is now in full management and control of the Boston & Montana Company, and of all its property, business and affairs, as well as of all other mining companies above mentioned; that the Amalgamated Copper Company is not entitled to

hold, own, or control any property or rights in the state of Montana or to carry on or conduct or direct any business therein, but all its aforesaid acts are in violation of section 20, art. 15, of the constitution of the state of Montana, and of sections 321 and 984 of the Penal Code of Montana. And the appellant alleged, on information and belief, that it is not the intention of the Amalgamated Copper Company to comply with the laws of the state of Montana allowing foreign corporations to carry on business within that state, or with any law of that state; and that at the time when the said Amalgamated Copper Company obtained possession of the stock of the Boston & Montana Company the latter company was possessed of money in the sum of \$6,000,000, of which the appellant and others similarly situated were entitled to their respective shares as stockholders of said company, but that the directors of the company, without right and against the authority and consent of the appellant, delivered over said money to the Amalgamated Copper Company, which company has converted the same to its own use. The appellant further alleged that the mining corporations above mentioned, organized under the laws of the state of Montana, including the Boston & Montana Company and also the Butte & Boston Consolidated Mining Company, organized under the laws of New York, had each a large number of valuable mines and mining claims in Silver Bow County; that a large number of the claims of the Boston & Montana Company are situated adjacent to or in the vicinity of mines belonging to the other companies; that the appellant is informed and believes that mine workings have been extended into the mines and mining claims of the Boston & Montana Company from other mines, and will hereafter be extended therein, and that one of the purposes of the organization and existence of the Amalgamated Copper Company and of its acquisition and control of the stock of the other companies was and is to arbitrarily determine what veins and ore beds belong to the respective claims and property owned by each of said mining companies and corporations, without the consent of the corporation or their stockholders, and to thereby devote to its own use and benefit such ore and minerals, and credit the same as an income from the property of such corporations; that the object and purpose of said Amalgamated Copper Company in acquiring the stock in the corporation above named was to control the output and price of minerals from the mines of all, and it will hereafter so conduct the mining operations in all as to affect the production and price of metal therefrom, and will charge against the appellant and other stockholders similarly situated an excessive amount for mining and disposition of the ores credited to the Boston & Montana Company, and that it has the power to shut down all or any of the mines controlled by it in Montana, and to close any or all of its smelters, or to permit the mines of the Boston & Montana Company to be worked by the other corporations, all to the great and irreparable injury of the appellant. The relief prayed for was (1) that it be adjudged and decreed that the Amalgamated Copper Company, its officers and agents, have no right to any of the shares of the capital stock of the Boston & Montana Company; that the same be canceled and surrendered up to the latter company; that the Amalgamated Copper Company, its officers, agents, and trustees, be enjoined from voting any of said shares, and that they be enjoined from ordering, directing, or controlling any of the officers and agents of the Boston & Montana Company with reference to property, business, or affairs of said company; (2) that the Boston & Montana Company, its officers, agents, and representatives, be enjoined from making or allowing any transfer on the books of that corporation of any of the shares of the stock now held or which may be procured by the Amalgamated Copper Company, or its officers or agents, and from allowing or permitting any of said shares to be voted by the Amalgamated Copper Company, its officers or agents; (3) that the directors of the Boston & Montana Company be enjoined from acting as directors or officers thereof; (4) that the said exchange of stock between the two said companies be declared null and void, and set aside and vacated, and that all moneys belonging to the Boston & Montana Company be accounted for and paid over to that company or its receiver; (5) that the Amalgamated Copper Company be declared a trust and monopoly, and that it be forever enjoined from carrying on any business

with the property of the Boston & Montana Company, within the state of Montana or otherwise, or in any wise interfere therewith, or doing any business whatsoever within said state, either directly, or by the acts or assistance or advice of any person or corporation whatsoever; (6) that a receiver for all the property and business of the Boston & Montana Company be appointed; (7) that an injunction be granted the appellant pending the final determination of the suit to prevent any unlawful act upon the part of the defendants and to preserve his rights as a stockholder in the Boston & Montana Company.

After the removal of the cause from the state court to the circuit court a motion was made to remand upon the ground that no separable controversy exists as to the removing corporation. The motion was denied. Thereafter, upon the application of the appellees, and upon the ground that a prior suit was pending in the state court between the same parties, involving the same subject-matter, the circuit court enjoined the appellant from further prosecuting the present suit. From that injunction order the appeal is taken. One of the grounds of error relied upon by the appellant is that the circuit court erred in denying the motion to remand.

McHatton & Cotter, for appellant.

Forbis & Evans (C. F. Kelly, of counsel), for appellee.

Before GILBERT, ROSS, and MORROW, Circuit Judges.

GILBERT, Circuit Judge, after stating the case as above, delivered the opinion of the court.

We think that the cause was improperly removed to the circuit court. Although the prayer of the complaint seeks relief expressed in varying form, as against the Amalgamated Copper Company, the cause of suit is substantially one. It is the question of the right of the Amalgamated Copper Company to control the property, business, and corporate stock of the Boston & Montana Company in the manner which is set forth in the bill. The appellant, as plaintiff in the suit, is interested in no corporation other than the Boston & Montana Company. He challenges the right of the Amalgamated Copper Company to interfere with the business affairs of his corporation and to take over its property. The illegality of this interference, as alleged in the bill, is predicated upon different grounds, but the sole aim and purpose of the suit is to dissolve the combination which has been formed between the two corporations, and to protect the interest of the appellant as a stockholder of the Boston & Montana Company. It is evident at a glance that the Boston & Montana Company is a necessary party to every phase of the controversy, unless it be that the relief prayed for in the fifth subdivision of the prayer presents matter in which it has no concern. It is true that in a portion of the relief which is there sought the prayer goes further than the averments of the bill, and asks that the Amalgamated Copper Company be debarred from doing business within the state of Montana. This prayer for relief does not create a separate controversy. The suit is not brought to dissolve the Amalgamated Copper Company or to enjoin it from doing business in the state of Montana. Where the relief sought against one of several defendants is merely incidental to the principal purpose of the suit, the fact that such incidental relief pertains to one only of the defendants does not make it a separable controversy so as to give him the right of removal. *Safe-Deposit Co. v. Huntington*, 117 U. S. 280, 6 Sup. Ct. 733, 29 L. Ed. 898; *Graves v. Corbin*, 132

U. S. 571, 10 Sup. Ct. 196, 33 L. Ed. 462; Torrence v. Shedd, 144 U. S. 527, 12 Sup. Ct. 726, 36 L. Ed. 528; Bellaire v. Railroad Co., 146 U. S. 117, 13 Sup. Ct. 16, 36 L. Ed. 910; Brown v. Trousdale, 138 U. S. 389, 11 Sup. Ct. 308, 34 L. Ed. 987; Mayor, etc., of New York v. New Jersey Steamboat Transp. Co. (C. C.) 24 Fed. 817; City of Le Mars v. Iowa Falls & S. C. R. Co. (C. C.) 48 Fed. 661; Ames v. Railroad Co. (C. C.) 39 Fed. 881. The prayer that the Amalgamated Copper Company be declared a trust and a monopoly is only incidental to the other relief which is prayed for in connection therewith, namely, that it be enjoined from controlling the Boston & Montana Company; and the same was evidently true, in the mind of the pleader, of the further prayer that the Amalgamated Copper Company be enjoined from doing business in the state of Montana. Not only is the relief so sought plainly incidental to the main purpose of the suit, but the bill contains no averment upon which such relief could be obtained. No fact is alleged to show a right in the appellant to demand such an injunction. He exhibits, therefore, no controversy as to his right to such relief. In order to show the existence of a controversy, facts must be alleged upon which the court can see that a question is presented for its determination. The court will not search the record for a mere fanciful controversy. The controversy must be real, and must be apparent upon the face of the bill. The appellant sues in no official capacity, but as a private citizen for the protection of his individual rights. He had no authority to sue in the interests of the public, or to obtain an injunction against the transaction of business by the Amalgamated Copper Company in the state of Montana, or to obtain any relief save such as affected his property rights as a stockholder in the Boston & Montana Company. *Thomp. Corp.*, §§ 502, 1852, 7944.

It is suggested that the real controversy in this case is between the two corporations, and that the appellant is but a formal party, since the suit is one to enforce the right of the Boston & Montana Company. It is clear, however, from the allegations of the bill, that the Boston & Montana Company is not a party in the same interest with the appellant. If it be true that it has conspired with the Amalgamated Copper Company to do the illegal acts which are charged, both the corporations are antagonistic to the appellant, and both are necessary parties defendant to the suit. In a similar case the supreme court said:

"Grayson is not suing for the Memphis & Charleston Company, but for himself. It is true a decree in his favor may be for the advantage of the Memphis & Charleston Company, but he does not represent the company in its corporate capacity, and has no authority to do so. As a stockholder he seeks protection from the illegal acts of his own company as well as the other." *Railroad Co. v. Grayson*, 119 U. S. 240, 244, 7 Sup. Ct. 190, 30 L. Ed. 382.

Of similar import is *Railroad Co. v. Mills*, 113 U. S. 249, 5 Sup. Ct. 456, 28 L. Ed. 949.

The decree will be reversed, and the cause remanded to the circuit court, with instructions to remand the same to the state court, whence it was removed.

KIMBELL et al. v. CHICAGO HYDRAULIC PRESS BRICK CO. et al.

(Circuit Court of Appeals, Eighth Circuit. November 12, 1902.)

No. 1,735.

1. CORPORATIONS—SUIT BY STOCKHOLDER FOR CANCELLATION OF STOCK—SUFFICIENCY OF BILL.

A bill by a stockholder, praying for the cancellation of stock issued by a corporation 10 years previously in payment for the exclusive right to operate under certain patents for the manufacture of bricks within a prescribed territory, which right, it is alleged, was of no value, does not state a cause of action for relief on that ground, although the stock was issued under a statute providing that such corporations should issue stock only "for money paid, labor done or money or property actually received"; there being no allegation in the bill that the exclusive rights, on account of which the stock was issued, were known or believed to be valueless at the time of the transaction, and there being no allegation in the bill that the exclusive rights in question were not properly assigned to the corporation, and no allegation that the corporation had not exercised the exclusive rights or operated under the patents so acquired. *Held*, further, that, in the absence of such allegations as those last mentioned, it might well be inferred that the stock was issued in exchange for rights that were supposed at the time to be of great value, and that the rights so acquired had been thereafter continuously exercised.

2. SAME—LACHES.

A stockholder is barred by laches from maintaining a suit in equity for the cancellation of stock issued by the corporation, and to charge the holder as trustee with the amount of dividends received, on the ground that the issuance of the stock was ultra vires, under the state statute, where it was issued 10 years before the bill was filed, during all of which time complainant was a stockholder, and where there was no concealment of the transaction, which was fully shown by a resolution of the directors appearing of record in the proper minute book of the corporation.

Appeal from the Circuit Court of the United States for the Eastern District of Missouri.

This case passed off below on a demurrer to a second amended bill of complaint, which demurrer was sustained; whereupon the complainants submitted to a decree dismissing the bill, and appealed.

The bill is very lengthy, but the material facts averred are as follows: Charles B. Kimbell and Libbie A. Kimbell, the complainants below and the appellants in this court, are stockholders in the Chicago Hydraulic Press Brick Company, a Missouri corporation, which is hereafter referred to as the Chicago Company. Charles B. Kimbell owns 100 shares of stock, of the par value of \$100 each, represented by a stock certificate dated July 10, 1890. Libbie A. Kimbell, as the devisee of her husband, J. W. Kimbell, is the owner of 50 shares of stock, represented by several certificates, which were issued on July 9, 1891, and previously. All of said stock was issued on the full payment of subscriptions therefor which were made by Charles B. Kimbell and J. W. Kimbell prior to March 17, 1890. J. W. Kimbell died July 16, 1897. Edward C. Sterling is the president and Henry W. Eliot is the secretary and treasurer of the Chicago Company, and they have respectively filled those offices since the corporation was organized, on February 18, 1890. The same individuals also hold the same offices, respectively, in another Missouri corporation, the Hydraulic Press Brick Company (one of the appellees), which is hereafter referred to as the St. Louis Company, and they have held the offices in question in the latter company since February 18, 1890. The capital stock of the Chicago Company was fixed in its articles of association at \$600,000, one-half of which, as its articles of association, when filed, declared, had been paid for in cash; but the complainants are

informed that the statement to that effect was untrue, and that the payment was in fact made with valueless and useless patents. On July 18, 1890, the Chicago Company issued to Edward C. Sterling, as trustee for the St. Louis Company, a certificate for 3,200 shares of its capital stock. This certificate was subsequently, on February 5, 1901, reissued to Henry W. Eliot, as trustee, for 3,047 shares, a certain portion of the stock originally held in trust having at that time been sold. This stock was issued to Sterling as trustee, and subsequently to Eliot as trustee, for a pretended license to use certain patented machines, namely, two hydraulic press brick machines, fourteen kilns, and one pulverizer, which the Chicago Company bought of the St. Louis Company, paying therefor, as it is said, their full value. On March 17, 1890, a resolution was passed by the directors of the Chicago Company, approving of a purchase from the St. Louis Company of the exclusive right to use certain patents controlled by the latter company, within a circle having a radius of 100 miles, whose center was the Board of Trade Building in the city of Chicago, Ill., for the price and sum of \$300,000. This resolution, the complainants say, was illegally adopted because only five of the seven directors of the Chicago Company were present at the meeting, among whom were Sterling and Eliot, who are said to have been disqualified from voting because they were heavily interested in the St. Louis Company, and because a by-law of the Chicago Company declared that at special meetings no action taken should be deemed binding unless adopted by a majority of the full board of directors. The complainants have no knowledge of the assignment of any patents by the St. Louis Company to the Chicago Company except as shown by the aforesaid resolution of March 17, 1890. They believe that the St. Louis Company did not own any patents covering brick machines and mechanical devices and processes for the making of brick. They say, however, that it did obtain a license under or an assignment of certain patents for brick-making machines from one Graves, on May 19, 1890, but complainants are not aware of the terms of that license or assignment. The resolution to pay the St. Louis Company \$300,000 for the use of its patents as aforesaid was the only consideration for the issuance of the aforesaid shares of stock to Sterling, and for the subsequent issue of stock to Eliot, as trustee for the same company. By the aforesaid arrangement to pay \$300,000 for the use of patents, the Chicago Company's stockholders were defrauded to the extent of \$320,000, the par value of the stock so issued. The restriction placed upon the use of the brick machines which were purchased as aforesaid from the St. Louis Company, confining their use within a circle having a diameter of 200 miles, was in violation of public policy and the patent laws of the United States. The St. Louis Company actively promoted the organization of the Chicago Company. No prospectus was issued at the time of the organization of the Chicago Company showing what was intended, and the complainants did not ascertain what had been done until March 14, 1901, when they investigated the books of the Chicago Company and found out. The complainants are advised that the St. Louis Company had no right to hold stock in the Chicago Company nor the latter company the right to issue stock except for its par value in money or property actually received. The Chicago Company has paid dividends on the stock held by the St. Louis Company to the amount of about \$151,000. The stock in question was issued to the St. Louis Company for promoting the Chicago Company, the license granted to use its patents being of no real value. The complainants say that they had no notice of the illegal issuance of said stock or a suggestion putting them on inquiry. Moreover, that the transaction was not called to their attention and does not appear on the books of the Chicago Company except as it is disclosed by the aforesaid resolution of March 17, 1890, to purchase the right to use certain patents, for the sum of \$300,000. One of the complainants, Charles B. Kimbell, has been an invalid since 1888. The complainants sue in behalf of all stockholders, and pray that the 3,047 shares of stock be canceled; that a judgment be entered in favor of the Chicago Company and against the St. Louis Company for all dividends paid to the St. Louis Company on the stock in question; that Sterling and Eliot be enjoined from voting the stock at any stockholders' meeting of the Chicago Company; and that, if anything was given for the stock when it was issued, whatever was given

be restored to the person or persons to whom it of right belongs, on the cancellation of the stock.

Edmund H. Smalley and Edward A. Rozier, for appellants.
Edward Cunningham, Jr., for appellees Hydraulic Press Brick Co.,
Edward C. Sterling, and Henry W. Eliot.

W. Christy Bryan, for Chicago Hydraulic Press Brick Co.

Before SANBORN and THAYER, Circuit Judges, and LOCHREN, District Judge.

THAYER, Circuit Judge, after stating the case as above, delivered the opinion of the court.

In view of the allegations of the bill, the substance of which have been stated above, it is apparent that as early as March 17, 1890, the corporation in which the complainants are stockholders, namely, the Chicago Hydraulic Press Brick Company, agreed to issue to the Hydraulic Press Brick Company \$300,000 worth of its capital stock in exchange for the exclusive right to operate under patents which the latter company controlled, such operations to be confined to a circle of territory 200 miles in diameter, which included the city of Chicago, and that in pursuance of that agreement stock to the amount of \$300,000 was issued to the St. Louis Company, and has been outstanding ever since, and treated as in every respect valid. The bill does not aver that the St. Louis Company never owned or controlled any patents on machines or processes for making brick, as the complainants might easily have done, if such were the fact; they merely aver that they have no knowledge that any assignments of patents were executed or licenses granted in favor of the Chicago Company, and that the St. Louis Company did not own any patents on March 17, 1890; but it is not averred that it did not subsequently acquire the control of patents upon machines or processes for manufacturing brick, nor is it averred that the St. Louis Company failed to secure to the Chicago Company such exclusive right to use the patents, controlled by itself, as it had agreed to secure. In the absence of explicit allegations to this effect, which might have been made, it must be assumed that on March 17, 1890, or shortly thereafter, the St. Louis Company secured control of certain patents on machines or processes for manufacturing brick, and that whether such machines or processes were valuable or otherwise the Chicago Company secured the right to use them within certain prescribed territory, which right has never been challenged by any one. The averments of the bill tending to create the impression that the St. Louis Company never controlled any patents, and never secured to the Chicago Company the right to use them, are exceedingly vague, evasive, and uncertain, evidencing an intention to create an impression that such were the facts, without ascertaining what the facts were in this respect, and alleging them specifically. This method of pleading in a bill in equity—that is to say, a method whereby a part of the facts connected with a given transaction are alleged and other facts are withheld which, if unknown, might easily have been discovered and related on oath—is subject to just criticism, and warrants a chancellor in

presuming that whatever was left untold is unfavorable to the complainants' case.

The gravamen of the complaint is that more than 11 years before this action was instituted (the original bill having been exhibited on May 2, 1901) the Chicago Company, a Missouri corporation, engaged to issue one-half of its capital stock for the exclusive right to operate within certain territory under certain patents relating to the manufacture of brick, which patents, and the licenses given to operate thereunder, were of no value; that it did in fact issue one-half of its capital stock upon such a consideration although the law under which the corporation was organized (Rev. St. Mo. § 962) declared that stock in such corporations should "be issued only for money paid, labor done, or money or property actually received"; and that by reason of these facts the other stockholders of the company were greatly damaged. It is not averred, however, that the exclusive right to operate under the patents in question was known to the defendants or any of them to be of no value when the stock was issued, nor is it averred in the bill that the Chicago Company did not operate under the patents and did not exercise the exclusive rights which it had acquired. The bill shows very clearly that the Chicago Company has been making brick for the past 10 years, and has in the meantime paid dividends amounting to more than one-half of its entire capital, and for aught that is alleged in the bill the exclusive right to operate under the patents may have been esteemed of great value when the stock was issued in exchange therefor, and it may also be that the right in question has been exercised continuously by the Chicago Company from the time it was organized to the present date. If the facts are otherwise they might and should have been alleged specifically. The bill contains nothing that would warrant a contrary conclusion unless it be an allegation that when the Chicago Company purchased certain brick machines from the St. Louis Company and paid for them it thereby acquired the right to use them without any further license. It may be, however, that the sale of these brick machines was a part of the same transaction by which the stock was acquired, and that these machines would not have been sold to the Chicago Company but for the reason that it had engaged to purchase from the St. Louis Company the exclusive right to operate under certain patents for the manufacture of brick which the latter company controlled. In short, it may well be inferred, notwithstanding all the averments of the complaint, that the stock which was issued to the St. Louis Company was issued in exchange for rights that were supposed at the time to be of great value, and that these rights, such as they were, have been exercised continuously to the present time.

Let it be conceded, however, that the bill does show by proper averments that one-half of the stock of the Chicago Company was issued originally to the St. Louis Company in exchange for property that was of no value or of comparatively small value, and the question then arises whether complainants can be heard at this late day to complain of the transaction or are barred by laches. The wrong was committed more than 11 years before the bill was exhibited, and in the meantime it might have been discovered by the complainants or any other stock-

holder by the exercise of the slightest diligence. As stockholders, they were entitled at all times to have access to the books of the company, and even a casual examination of the corporate books would have disclosed the consideration that was received originally for the stock in question which, as it is now claimed, was issued illegally. The bill shows that when the complainants moved in the matter and investigated the company's books they had no difficulty in discovering what was received for the stock, and all the information that they now possess seems to have been derived from that source. No reason is perceived nor is any sufficient reason alleged why they did not discover the alleged wrong at an earlier period, since the bill utterly fails to disclose any acts on the part of the defendants or either of them which amount to an actual concealment of the wrong. The resolution to purchase certain exclusive rights from the St. Louis Company for the sum of \$300,000 was spread upon the records of the company, where it of right belonged, and in view of that circumstance it is hardly conceivable how the complainants could have been ignorant of the manner in which the large sum of money agreed to be paid for such rights was in fact paid. At all events, if the complainants had at any time taken the trouble to inquire how this liability had been discharged or what amount of money or property had been received by the company in exchange for its capital stock, the whole transaction of which complaint is now made would have been discovered. The case is one, therefore, where the complainants' want of knowledge of the objectionable transaction was due to a lack of diligence in inquiring into matters in which they were deeply concerned; and even if it were true that an actual fraud was intended, and that the wrong complained of is something more than an ultra vires act, committed by the directors of the Chicago Company, still it does not appear that the wrongdoers concealed the transaction, for such facts as are alleged do not amount to concealment, and cannot be accepted as an excuse for a failure to discover the alleged violation of the statute, or the fraud, whichever it may be.

Under these circumstances, it is well settled by repeated decisions that complainants are barred of their right to relief. Courts of equity are not disposed to upset business transactions, or to disturb titles, that have passed unchallenged for years; and they will not do so unless at the instance of a suitor who has been diligent and persevering in the pursuit of his rights, and who can and does show good and sufficient reasons for not making an earlier application for relief. This doctrine is elementary, and has been frequently reiterated and applied, especially by the federal courts. *Wood v. Carpenter*, 101 U. S. 135, 139, 25 L. Ed. 807; *Speidel v. Henrici*, 120 U. S. 377, 7 Sup. Ct. 610, 30 L. Ed. 718; *Felix v. Patrick*, 145 U. S. 317, 12 Sup. Ct. 862, 36 L. Ed. 719; *Wetzel v. Transfer Co.*, 12 C. C. A. 490, 493, 494, 65 Fed. 23; *Kinne v. Webb*, 4 C. C. A. 170, 54 Fed. 34; *Naddo v. Bardon*, 2 C. C. A. 335, 51 Fed. 493. In this case an attempt is made to charge the St. Louis Company as constructive trustee with a large sum of money which has been paid to it during the course of 11 years as dividends upon stock, which stock, as it is said, was unlawfully issued. If this be so, the state of Missouri, in the exercise of its visitorial pow-

ers over domestic corporations, may take steps to redress the wrong. Where an attempt is thus made to charge one as a constructive trustee of money or property, the rule, requiring a private suitor to be diligent and to plead and establish some adequate excuse for his silence and inaction during a period of years, is strictly enforced. *Wetzel v. Transfer Co.*, supra. The usual limitation at law applicable to actions for relief on the ground of fraud is five years after the discovery of the fraud, and such is the law in Missouri. Rev. St. 1899 (Mo.) § 4273. The wrong or fraud complained of in the present instance should have been discovered, and would have been discovered by the complainants almost as soon as it was committed, if they had exercised even ordinary diligence. Indeed, it is difficult to understand why the alleged wrong was not discovered at that time. Acting in analogy with the rule prescribed for the governance of courts of law, it must now be held that in the forum of equity, where as much if not greater diligence must be exercised, these complainants were not entitled, on the showing made in their bill, to equitable relief, and it was properly dismissed by the lower court. Several other questions were discussed at length on the argument, but it seems unnecessary to notice them in view of the ruling that the complainants' right to relief is barred by laches.

The decree below is affirmed.

EGAN STATE BANK v. RICE.

(Circuit Court of Appeals, Eighth Circuit. November 26, 1902.)

No. 1,660.

1. BANKRUPTCY—CHATTEL MORTGAGE—VALIDITY.

Under Bankr. Act 1898, § 67e [U. S. Comp. St. 1901, p. 3449], providing that incumbrances of property made by one adjudged bankrupt within four months prior to the filing of the petition, with intent to hinder or defraud his creditors, shall be void as against them, a chattel mortgage given by a merchant to a bank on his stock in trade within four months prior to his bankruptcy, he retaining possession under an agreement that the proceeds of sales should go to pay the mortgage and other debts, and he from the proceeds paying expenses and debts in general, is void, as against the creditors, notwithstanding the fact that it contained a provision requiring the merchant to make daily deposits of all sales, to apply on the debt to the bank.

Appeal from the District Court of the United States for the District of South Dakota.

Henry H. Platts, a retail merchant of Egan, S. D., on December 8, 1899, borrowed of the appellant bank \$600 on his promissory note, payable in six months, secured by chattel mortgage upon Platts' stock of merchandise, except groceries. This mortgage was recorded August 10, 1900. In the meantime six months' interest was paid June 8, 1900, and the note was then extended, by writing indorsed thereon, for another six months. On November 2, 1900, Platts borrowed of appellant bank the further sum of \$500, and took up his previous note, and then executed to said bank his 11 new promissory notes, for varying amounts, but in all aggregating \$1,100, and payable one on the last day of every month from that date until September 30, 1901, with annual interest at 12 per cent., all secured by another chattel mortgage, made November 2, 1900, covering Platts' entire stock of merchandise and his store fixtures, and any additions to or replacements of the stock, and was

further to secure all further advances that might be made to Platts by the bank. And thereby Platts further agreed to make daily deposits of all sales of goods, to apply on the notes so secured, until all should be paid. This chattel mortgage was recorded November 8, 1900. From the giving of the first chattel mortgage until Platts' business was closed by the proceedings in bankruptcy, he dealt with said bank as an ordinary depositor, depositing therein from the proceeds of his sales at least \$2,500, of which from \$300 to \$400 was so deposited after November 2, 1900. He paid therefrom on his debt to the bank, aside from the interest so paid in June, only one note, for \$75, which was secured by the last mortgage, and due November 30, 1900, but not paid till December 8, 1900. All the rest of such deposits were, with the consent of the bank, paid out on checks of Platts, and used to pay other creditors, or for other uses. Upon the petition of creditors, filed December 13, 1900, Platts was adjudicated a bankrupt January 3, 1901, and the appellee, George Rice, was thereafter duly appointed trustee of his estate in bankruptcy; and, by order of the court, the stock of merchandise of the bankrupt was sold free of incumbrance. On the petition of the bank an order was made that the trustee show cause why the claim of the bank, secured by the chattel mortgage, should not be paid in full from the proceeds of the property so sold. The referee in bankruptcy, to whom the matter was referred, heard the testimony and made his findings of fact, and, upon his conclusions of law therefrom, made his decision and order in favor of the bank. On request of the trustee, the referee certified the questions involved, with the testimony, findings of fact, and his legal conclusions, to the judge, for review. Upon full hearing before the judge, it was on August 20, 1901, ordered and adjudged that the order of the referee requiring the trustee to pay to the Egan State Bank the amount secured by said chattel mortgage of November 2, 1900, be vacated and set aside, with the findings of fact and conclusions of law on which said order was based, and further that such chattel mortgage is null and void, and no lien on the assets in the hands of the trustee. From this judgment or decree this appeal is taken. A fuller report of the case in some particulars, especially in respect to the findings and conclusions of the referee, will be found in the decision of the learned judge of the district court. In re Platts (D. C.) 110 Fed. 126.

E. R. Winans (A. B. Kittridge and W. D. Scott, on the brief), for appellant.

J. Q. Adams (George Rice, on the brief), for appellee.

Before SANBORN and THAYER, Circuit Judges, and LOCHREN, District Judge.

LOCHREN, District Judge, after stating the case as above, delivered the opinion of the court.

This appeal questions the correctness of the decision of the learned district judge that upon the evidence it appears that the chattel mortgage of November 2, 1900, made by Platts to the bank, was made by him with intent to hinder and delay his creditors, and was therefore null and void as to his creditors, by the law of South Dakota in respect to such conveyances, as well as under the bankruptcy act of 1898 [U. S. Comp. St. 1901, p. 3418]. Section 67e of this act [U. S. Comp. St. 1901, p. 3449] provides as follows:

"That all conveyances, transfers, assignments, or incumbrances of his property, or any part thereof, made or given by a person adjudged a bankrupt under the provisions of this act subsequent to the passage of this act and within four months prior to the filing of the petition, with the intent and purpose on his part to hinder, delay, or defraud his creditors, or any of them, shall be null and void as against the creditors of such debtor, except as to purchasers in good faith and for a present fair consideration; and all property of the debtor conveyed, transferred, assigned or encumbered as

aforesaid shall, if he be adjudged a bankrupt, and the same is not exempt from execution and liability for debts by the law of his domicile, be and remain a part of the assets and estate of the bankrupt and shall pass to his said trustee, whose duty it shall be to recover and reclaim the same by legal proceedings or otherwise for the benefit of the creditors."

See, also, section 70, subd. 4 [U. S. Comp. St. 1901, p. 3451].

The chattel mortgage under consideration was given by Platts November 2, 1900, within four months of the filing of the petition, December 13, 1900, under which he was adjudged a bankrupt. The district court held that, even if it were valid upon its face, yet the evidence showed clearly that it was given by Platts with the intent and purpose on his part to hinder and delay his creditors, and was therefore null and void as against them, and the trustee who represents them.

The law applicable to such case is stated very clearly in *Horton v. Williams*, 21 Minn. 187, 190, as follows:

"A mortgage of chattels, coupled with an agreement that the mortgagor may retain possession of the mortgaged property, and sell or dispose of it as his own, without satisfaction of the mortgage debt, is of no effect as a security, and can only operate to hinder, delay, and defraud the creditors of the mortgagor and subsequent purchasers and mortgagees. In the early case of *Chopard v. Bayard*, 4 Minn. 533 (Gil. 418), it was held by this court, in accordance with sound principle and the weight of authority, that such a mortgage was necessarily fraudulent as against the mortgagor's creditors. And see *Edgell v. Hart*, 9 N. Y. 213, 59 Am. Dec. 532; *Place v. Langworthy*, 13 Wis. 629, 80 Am. Dec. 758; *Steinat v. Deuster*, 23 Wis. 136; *Collins v. Myers*, 16 Ohio, 547; *Freeman v. Rawson*, 5 Ohio St. 1; *Bank v. Hunt*, 11 Wall. 391, 20 L. Ed. 190. If the intent that the mortgagor may retain possession of the goods, and dispose of them as owner, is apparent in the mortgage itself, the existence of such intent is to be determined by the court, otherwise the existence of the intent is a question for the jury upon the evidence; but in every case, if the intent is found to exist, the law declares the mortgage to be fraudulent. *Gere v. Murphy*, 6 Minn. 305 (Gil. 213); *Gardner v. McEwen*, 19 N. Y. 123; *Russell v. Winne*, 37 N. Y. 591, 97 Am. Dec. 755, and cases supra. The conduct of the parties in dealing with the mortgaged property may, however, furnish evidence, in some cases amounting to a moral certainty, that the mortgage was executed with a fraudulent intent. Thus, in the case of a mortgage on a stock of goods in a retail shop, when the mortgagor continues in possession, making sales from day to day as owner, and dealing with the goods and the proceeds as his own, with the mortgagee's knowledge and assent, it is extremely difficult to resist the conclusion that this course of conduct on the part of the mortgagor was contemplated and intended by the parties when the mortgage was made. See *Griswold v. Sheldon*, 4 N. Y. 581; *Freeman v. Rawson*, 5 Ohio St. 1; *Russell v. Winne*, 37 N. Y. 591, 97 Am. Dec. 755."

This is precisely what was done by Platts after giving the chattel mortgage of November 2, 1900. He continued to sell the goods, making no account of the sales to the bank, and to use the proceeds of the sales for the payment of other debts, or otherwise as he pleased, with the full knowledge and assent of the bank; paying on the secured debt only \$75 out of the \$300 to \$400 proceeds of sales realized by him from the mortgaged stock before he was stopped by the proceedings in bankruptcy. As the proceeds of the sales were deposited by him in the same bank as an ordinary customer and depositor, and paid out again by the same bank upon his checks, it would be clear, if there was no other evidence in the case, that such was the intention and

understanding of the parties when the mortgage was given. And this presumption is strengthened by the unquestioned fact that the mortgage of December 8, 1899, which continued till replaced by the mortgage under consideration, was of the same fraudulent character as to creditors. That prior mortgage was given to secure a note of \$600. While it existed, Platts deposited in the bank from the proceeds of his sales over \$2,000, and still used all that money himself, without paying a cent of the mortgage debt, except six months' interest. That the same course was continued under the subsequent mortgage is convincing evidence that such was the intention when the last mortgage was given. And the testimony of Mr. Struble, the cashier of the bank, was to the effect that, when the last mortgage was given, the agreement between the parties was that the money which Platts got from the sales of the mortgaged goods should go to pay the mortgage, and also to pay off his indebtedness, or, as Platts testified, he was to pay the notes to the bank as they became due, and apply the rest to the payment of debts he was owing for goods. In other words, so long as he should continue to pay the notes to the bank as they should successively mature, the goods and their proceeds were to be at his own disposal. Upon these facts, the legal effect of the last mortgage, as well as the earlier one, was to hinder and delay the creditors of Platts. The agreements which gave the mortgage this character and effect were made by Platts, and acted on by him, and were therefore intentional and of purpose on his part.

The decisions of the supreme court of South Dakota are in entire accord with *Horton v. Williams*, 21 Minn. 187, which is cited with approval in the earliest of the cases. *Greeley v. Winsor*, 1 S. D. 117, 45 N. W. 325, 36 Am. St. Rep. 720; *Id.*, 1 S. D. 618, 48 N. W. 214; *Mercantile Co. v. Gardiner*, 5 S. D. 246, 58 N. W. 557.

There was no error in the findings and decision of the district court, and the decree and order appealed from are affirmed.

McCLAINÉ v. RANKIN.

(Circuit Court of Appeals, Ninth Circuit. November 10, 1902.)

No. 793.

1. NATIONAL BANKS—ACTION BY RECEIVER TO RECOVER ASSESSMENTS—COMPLAINT.

A complaint in an action by the receiver of a national bank to recover an assessment from a stockholder sufficiently shows the capital stock of the bank, although not directly alleged, where it alleges that there were 500 shares, of the par value of \$100 each, and that the assessment was made ratably, at \$100 per share, and amounted to \$50,000.

2. SAME—NOTICE OF ASSESSMENT—EVIDENCE.

The testimony of a witness that in his capacity as receiver of a national bank he made personal demand upon a stockholder for the payment of an assessment, and that the stockholder admitted having received notice thereof, where uncontradicted, sufficiently shows notice and demand to support an action to recover the assessment.

3. SAME—AUTHORITY TO SUE.

Specific authority given by the comptroller to the receiver of a national bank to bring an action against a stockholder to recover an assessment

is not withdrawn or affected by a subsequent general authority to compromise or sell all the claims or assets of the bank.

4. SAME—DEFENSES—PRIOR ACTION BY RECEIVER.

An action brought by the receiver of a national bank against a stockholder to enforce a compromise agreement entered into for the settlement of the stockholders' liability for an assessment, but in which the receiver took a voluntary nonsuit, is not a bar to a subsequent action to recover the assessment, the stockholder having failed to carry out the compromise agreement, nor did the receiver's action in commencing such suit create an estoppel against him.

In Error to the Circuit Court of the United States for the Western Division of the District of Washington.

T. O. Abbott, for plaintiff in error.

Robert G. Hudson and Robert S. Holt, for defendant in error.

Before GILBERT, ROSS, and MORROW, Circuit Judges.

GILBERT, Circuit Judge. The receiver of the First National Bank of South Bend, Wash., brought an action against the plaintiff in error as a stockholder of said bank to recover a delinquent assessment. The cause was tried before the court without a jury, and judgment was rendered against the plaintiff in error for the sum of \$2,300, with interest and costs.

The plaintiff in error assigns as error that the circuit court overruled his demurrer to the complaint. It is contended that the complaint fails to state a cause of action, for the reason that it does not show the total amount of the capital stock of the insolvent bank. We think the complaint is sufficient. While it does not in direct terms state the total amount of the capital stock, it sets forth facts from which it may be inferred. It alleges that the total assessment upon the shareholders was \$50,000; that it was made ratably; that the assessment was \$100 upon each share; that there were 500 shares; and that their par value was \$100 each. From these averments it is plain that the capital stock was \$50,000.

It is assigned as error that the court sustained the demurrer of the receiver to the first affirmative defense of the answer of the plaintiff in error. In that defense it was alleged that on December 30, 1897, the former receiver of said bank had commenced an action against the plaintiff in error in the superior court of the state of Washington for the county of Pierce, to recover the same assessment, and that a judgment was rendered therein in favor of said receiver for the amount of \$2,300, which judgment, upon the application of the plaintiff in error, was subsequently vacated and set aside, and that thereafter, upon the application of the receiver, the action was dismissed without notice to the plaintiff in error and "without prejudice"; that thereafter, on the application of the plaintiff in error and with the consent of counsel for the receiver, the words "without prejudice" were struck from the judgment entry. It is contended that the judgment so pleaded in such affirmative defense constituted a bar to the present action, for the reason that the dismissal was not without prejudice, and was so entered with the consent of the receiver. By the provisions of sections 409, 411, 2 Hill's Code Wash., it will

appear that such a judgment of dismissal has not the effect which is contended for by the plaintiff in error, and that it is no bar to another action for the same cause.

It is contended that the court erred in admitting in evidence a certain exhibit which purported to be a copy of a notice served by the former receiver upon the plaintiff in error. The complaint had alleged a notice of the assessment and demand for its payment given and made to the plaintiff in error by the receiver, and this was denied by the answer. The receiver, to prove his cause of action, introduced the affidavit of Joseph G. Heim, the former receiver of said bank, together with the exhibit attached thereto. It was stipulated between the parties that the affidavit of Heim might stand in said cause for and as the testimony of said Heim in all respects as if it had been taken upon commission duly issued, or as if he were present in court; the plaintiff in error reserving an objection thereto on the ground of irrelevancy, immateriality, and incompetency only. It is contended now that the exhibit was incompetent testimony, for the reason that it was not the best evidence; that no notice or demand was served upon the plaintiff in error to produce the original notice; and that the copy, therefore, was secondary evidence. We do not find it necessary to consider this objection. It appears in the body of the affidavit that the affiant deposed to the fact that before the commencement of the action he made personal demand upon the plaintiff in error "for the payment of said assessment," and that the plaintiff in error admitted having received the notice and having knowledge thereof and of said demand. We think this was sufficient notice to and demand of the defendant in error, and that the admission of the exhibit, if it was error, was harmless.

It is contended that it affirmatively appears from the evidence that the receiver had no authority from the comptroller of the treasury to bring the present action. It is not denied that the record shows that there was originally authority to commence such an action, but it is contended that, inasmuch as authority was given subsequently to compromise the demand or to sell the same, it operated to retract the authority to sue. We think this assignment of error requires no extended discussion. The authority to bring the action was in no way curtailed or withdrawn by the authority to compromise or to sell the cause of action. The latter authority, so given, was a general power "to compromise and compound or sell at private sale all of the assets of said bank," including "claims due upon assessment of the capital stock." It was an authority entirely consistent with the specific authority previously given to bring suit. The receiver had the power to take either course so permitted by the comptroller.

It is contended, further, that the present action is barred by a second action which was brought for the purpose of enforcing the compromise which had been agreed upon between the receiver and the plaintiff in error at the time of the dismissal of the first action. It had been agreed as a compromise of said demand for said assessment that the plaintiff in error would convey to the receiver certain lots in South Bend, Wash., as a payment of the sum of \$415.83, \$215.83 whereof was to pay an account due to the bank from one

Morgan, and the remaining \$200 was to be credited to the plaintiff in error on the said assessment, and that thereafter the plaintiff in error would pay the remainder of his assessment in certain installments, all of which were to fall due within a year from the date of the compromise. It appeared that this agreement was not carried out by the plaintiff in error, except that he conveyed the lots to the receiver and received the stipulated credit therefor. In order to enforce the compromise the receiver brought the action upon the agreement, but before proceeding to judgment he took a voluntary nonsuit, which he had the right to do. We cannot see how that proceeding affects his power to prosecute the present action. The plaintiff in error failed to carry out his part of the agreement. The receiver has in the present action credited him with the \$200 so paid on account. We find no error in the ruling of the trial court in denying to this agreement of compromise the effect of a bar to the present action.

Equally without merit is the contention that the court erred in denying the motion of plaintiff in error for a judgment at the close of the trial, upon the ground that by instituting proceedings in the second action to enforce the compromise the receiver had elected that remedy and had thereby waived his right to pursue another. There is no question here of the right of election. Election refers to a choice between different forms of action based upon the same facts. These two actions relate to different states of fact. The former was brought to enforce an agreement of compromise. The receiver took a nonsuit therein, possibly for the reason that, as the answer of the plaintiff in error in the present action alleges, the compromise agreement had never been authorized or ratified by the comptroller. But, whatever may have been the reason, the receiver had the right to regard the compromise as abandoned, and to sue upon the assessment. He chose that course. He was not estopped to do so by reason of having instituted an action upon the compromise agreement.

It is contended that the liability of the plaintiff in error upon the assessment was satisfied by the payment of the \$200 and the conveyance of the lots; that in taking the \$200 the receiver became trustee for the plaintiff in error to secure the ratification of the proposal then submitted. This contention cannot be sustained. It is only necessary to advert to the fact, already alluded to, that the plaintiff in error failed to carry out his agreement of compromise, and that the receiver applied the \$200, which had been paid him, on the assessment, and in the judgment gave the plaintiff in error credit therefor. It is argued in this connection that the lots were of much greater value than \$415.83, and that the receiver still retains the title to the lots. It must not be forgotten, however, that the lots were turned over at an agreed price, and that they were conveyed for a double purpose—First, to pay the debt of \$215.83 owing by Morgan to the bank; and, second, to pay \$200 upon the assessment owing from the plaintiff in error.

We find no error in the record for which the judgment should be reversed. The judgment is affirmed.

HY-YU-TSE-MIL-KIN v. SMITH.

(Circuit Court of Appeals, Ninth Circuit. October 6, 1902.)

No. 766.

1. INDIANS—SUITS FOR ALLOTMENT OF LANDS—SPECIAL JURISDICTION OF CIRCUIT COURT.

Act Aug. 15, 1894 (28 Stat. 305), confers on a circuit court of the United States jurisdiction to decree relief to an Indian, entitled under the law to an allotment of certain lands, of which right he has been deprived by the rulings of the land department.

2. SAME—PARTIES.

The provision of such act, that the decree of the court in favor of a claimant in a suit brought thereunder shall have the same effect as an allotment allowed and approved by the secretary of the interior, is in effect a consent upon the part of the United States to be bound by such decree; and, where the suit involves simply a question of priority of right between two claimants, the United States is not a necessary party.

3. SAME—EQUITIES BETWEEN ALLOTTEES—PRIORITY OF SELECTION AND IMPROVEMENT.

It was the intention of congress by Act March 3, 1885 (23 Stat. 340), providing for the allotment of lands in severalty to members of the Walla Walla and other Indian tribes, which gave them the right to select the land they wished allotted to them, that, where more than one person selected the same land, the allotment should be made with reference to priority of selection, residence, and improvement, in accordance with the principle which has always been recognized in the disposition of public lands; and an Indian woman of the tribe, who selected and improved land with the consent of the tribal authorities, but whose right to an allotment was erroneously denied by the land department, cannot be deprived of her prior right to the land, so selected and improved, after such ruling has been reversed, by the fact that it had been subsequently allotted to another member of the tribe, who was put in possession, but who had full knowledge of her claim; nor is she estopped to assert her preferred right by the fact that she afterwards accepted a different allotment, with the understanding and on the assurance of the agent that it would not prejudice her right to claim that selected.

4. SAME—RIGHT TO ALLOTMENT—RESIDENCE ON RESERVATION.

Complainant, who was a full-blooded Indian woman of the Walla Walla tribe, did not forfeit her right to an allotment of land in severalty under Act March 3, 1885 (23 Stat. 340), because at the time the census list of those entitled to allotments was made up she was residing with her family outside the reservation, but on lands which members of the tribe were accustomed to occupy for hunting, fishing, or pasturage purposes, and which they were given the right to so occupy by treaty with the United States.

Appeal from the Circuit Court of the United States for the District of Oregon.

John H. Hall, U. S. Atty., for appellant.

R. J. Slater and J. T. Hinkle, for appellee.

Before GILBERT, Circuit Judge, and HAWLEY and DE HAVEN, District Judges.

DE HAVEN, District Judge. This is a suit in equity. The complainant is a full-blooded Indian woman, and a member of the Walla Walla band of Indians, residing in the state of Oregon. The prayer of the bill is that an allotment of a certain quarter section of land,

part of the Umatilla Indian reservation, made to the defendant, be canceled, and for a decree that the complainant was and is entitled to have said land allotted to her under the act of congress of March 3, 1885 (23 Stat. 340), providing for the allotment of lands in severalty to the Indians residing upon the Umatilla reservation in the state of Oregon. The decree of the circuit court was in favor of the complainant (100 Fed. 60), and from this decree the defendant has appealed.

1. The appellant contends that the circuit court was without jurisdiction of the cause; that under section 6 of the act of congress of March 3, 1885 (the act above referred to), the action of the secretary of the interior in making the allotment of the land in controversy was final, and cannot be made the subject of review in the courts. We are of the opinion, however, that the action was properly brought under the act of August 15, 1894 (28 Stat. 305), which provides:

"That all persons who are in whole or in part of Indian blood or descent who are entitled to an allotment of land under any law of congress, or who claim to be so entitled to land under any allotment act or under any grant made by congress, or who claim to have been unlawfully denied or excluded from any allotment or any parcel of land to which they claim to be lawfully entitled by virtue of any act of congress, may commence and prosecute or defend any action, suit or proceeding in relation to their right thereto, in the proper circuit court of the United States. And said courts are hereby given jurisdiction to try and determine any action, suit, or proceeding arising within their respective jurisdictions, involving the right of any person, in whole or in part of Indian blood or descent, to any allotment of land under any law or treaty. And the judgment or decree of any such court in favor of any claimant to an allotment of land shall have the same effect, when properly certified to the secretary of the interior, as if such allotment had been allowed and approved by him. * * *

This language is certainly broad enough to confer upon the circuit court jurisdiction to hear and determine the complaint of any person who is "in whole or in part of Indian blood," who claims "to have been unlawfully denied or excluded from any allotment or parcel of land" to which such person claims "to be lawfully entitled by virtue of any act of congress," and such is the nature of the bill filed by the complainant in this action.

2. The United States is not a necessary party to the suit. The matter in dispute here is between individuals, and involves simply a question of private right. We cannot see any necessity for making the United States a party to such an action, in the absence of a statute requiring that it shall be done. In answer to the suggestion that the United States is interested in the question to whom the land in controversy shall be allotted, and unless made a party to the action will not be bound by the decree, it is sufficient to say that the United States has, by the statute from which the above quotation is made, provided that a controversy of this character may be determined by an appropriate action in the circuit court, and that the decree therein shall have the same effect as an allotment allowed and approved by the secretary of the interior. An allotment made by or under the direction of the secretary of the interior entitles the allottee to a patent for the land allotted to him. Section 1, Act March 3, 1885

(23 Stat. 340). The provision in the statute that the decree of the court in an action like this shall have the same effect as an allotment made by the secretary of the interior gives to the successful party the right to a patent for the land allotted to him by the decree, and is in effect a consent upon the part of the United States to be bound by such decree and to issue its patent in accordance therewith.

3. We now proceed to inquire whether the decree of the circuit court is right upon the merits. The complainant is an Indian woman of full blood, a member of the Walla Walla tribe of Indians. In the year 1887 she, with the consent of the chiefs of the Walla Walla and Cayuse Indians, selected the land in controversy with the intention of having the same allotted to her under the act of March 3, 1885 (23 Stat. 340), and she and her husband improved it by the erection thereon of a granary and two barns, and also inclosed it, together with other lands selected by her for her family. The total value of these improvements, when made, was about \$700. The land was allotted to defendant in the year 1891. He did not have possession thereof at the time, or any improvements thereon. When the allotment was made the complainant was in possession of the land in controversy, although she and her family were actually residing upon other land, with which it was inclosed. Prior to its allotment to defendant, the complainant requested the commissioners appointed for the purpose of making allotments of land on the Umatilla reservation to allot the same to her; but they refused so to do because her name was not upon the census list of persons entitled to an allotment, and this action was approved by the department of the interior. It also appears that the census list was completed on June 7, 1887, and complainant was at that time living outside of the reservation upon lands which members of her tribe had been accustomed to occupy for hunting and fishing, and she did not take up her actual residence upon the reservation until shortly after the census was taken. At the time of receiving the allotment of the land in controversy, the defendant had notice of all these matters. The complainant continued in possession of said land until the fall of 1896, when she removed therefrom in obedience to orders given her by the Indian agent in charge of the Umatilla Indian reservation. In April, 1897, the secretary of the interior decided that complainant was entitled to an allotment of land on the Umatilla Indian reservation, and in pursuance of that decision certain lands were allotted to her, and she accepted the same, after being informed by the Indian agent that in his opinion such acceptance would not prejudice her right to the land in controversy. Since that time she has leased a portion of the land so allotted to her and received a stipulated rent therefor. Upon these facts we entertain no doubt of the justice of the decree of the circuit court. Under the act of congress of March 3, 1885 (23 Stat. 340), it is provided that:

"All allotments to heads of families, and to children under eighteen years of age belonging to families, shall be made upon selections made by the heads of the family, and allotments to persons over eighteen years of age not classed as heads of families shall be made upon the selection of such persons."

Section 6 of the act further provided that the secretary of the interior should "have power to determine all disputes and questions arising between Indians respecting their allotments." The statute conferred upon the Indians the right of selecting the land which they wished to have allotted to them; and, if there is only one claimant to a tract, such claimant is entitled to receive an allotment thereof. If, however, more than one person makes selection of the same tract, we think it was the intention of congress that the allotment should be made with reference to priority of selection, residence, and improvements. This is the principle by which the government has always been governed in the disposal of its public lands. *Shepley v. Cowan*, 91 U. S. 330, 23 L. Ed. 424. And, although the statute does not expressly so declare, we have no doubt that it must be so interpreted as to make it the duty of the secretary of the interior, in determining disputes and questions arising between Indians respecting their allotments, to proceed upon this principle. The complainant was, therefore, by reason of her selection of the same, and prior possession and improvements thereon, equitably entitled to have the land in controversy allotted to her; and the only reason why her right was not recognized by the secretary of the interior was because she was not residing upon the reservation when the commission appointed for that purpose made up the list of those entitled to take lands in severalty. This was an erroneous view of the law. Under the treaty of June 9, 1855, made with the Walla Walla, Cayuse, and Umatilla Indian tribes (12 Stat. 945), the privilege of hunting, gathering roots and berries, and pasturing their stock on unclaimed lands, in common with citizens, and to fish in the streams bordering on the reservation, in which they had been accustomed to fish, was reserved to the Indians; and the complainant did not forfeit her right to an allotment by living with her family upon lands which her tribe had been accustomed to occupy. She was upon the reservation, and in possession of the land in controversy, and had selected the same, before it was claimed by or allotted to defendant; and more was not required of her in order to give her an equitable right thereto as against him. In denying her right to the allotment claimed by her, the secretary of the interior committed an error of law, which can be corrected by a court of equity, in accordance with the rule declared in *Johnson v. Towsley*, 13 Wall. 78, 20 L. Ed. 485, *Moore v. Robbins*, 96 U. S. 530, 24 L. Ed. 848, and *Shepley v. Cowan*, 91 U. S. 340, 23 L. Ed. 424.

Nor is the complainant estopped from maintaining this action by the subsequent action of the government in allotting other lands to her. She accepted the allotment made to her upon the assurance of the Indian agent in charge of the reservation that her claim to the land in controversy would not be prejudiced thereby. No patent has been issued for the land so allotted to her, and no further action on her part is necessary in order to authorize the government to cancel such allotment. Certainly the defendant has been in no wise injured by this subsequent action of the complainant. If she had accepted the land allotted to her in satisfaction of her claim under the treaty and act of congress, a different question would be presented.

The decree of the circuit court is affirmed.

THE DEL NORTE.

TOWNSLEY et al. v. CRESCENT CITY TRANSP. CO.

(Circuit Court of Appeals, Ninth Circuit. October 27, 1902.)

No. 801.

1. SHIPPING—DEMISE OF VESSEL FOR TERM—LIABILITY OF OWNER FOR WRONGFUL ACTS OF OFFICERS.

By a charter of a steamship the entire ship was let and delivered to the charterer for the term of four months, under the express and distinct agreement that he should have full charge of her and be entitled to all her earnings; that all of the officers of the vessel, including the master, engineer, and steward, who were to be appointed by the owner, should be "in all respects under the order and direction" of the charterer, and subject to removal on his complaint; that he should redeliver the ship to the owner at the expiration of the term in as good order and condition as she was at the time of the agreement, with certain exceptions of usual wear and tear and damages arising from sea perils and inevitable casualties. It further provided that in case the charterer should fail to pay the rental at the times specified, or the operating expenses, including wages, the owner should have the right to retake possession, and that on his request the master should take and hold possession of the ship as his representative. *Held*, that such charter constituted a demise of the vessel, and that neither the master nor steward could be regarded as agents of the owner during the life of the charter, so as to charge him or the vessel with liability to the charterer on account of their alleged wrongful acts.

Appeal from District Court of the United States for the Northern Division of the District of Washington.

Pratt & Riddle and James Kiefer, for appellants.

Harold Preston, E. M. Carr, and L. C. Gilman, for appellee.

Before GILBERT, ROSS, and MORROW, Circuit Judges.

ROSS, Circuit Judge. In 1898 the appellee, owner of the steamer Del Norte, chartered her to the appellant Townsley for a term commencing on the 6th day of June of that year and ending on the 6th day of October, 1898, under which charter the vessel was delivered to Townsley, who retained possession thereof until about September 3, 1898, when, because of his failure to pay the rent stipulated by the charter to be paid, the owner, the Crescent City Transportation Company, took possession of the vessel. Thereupon Townsley libeled the ship for damages, alleging that he had suffered certain specified losses and damages by reason of the misconduct of the master and steward of the ship and the dishonesty of the master during the time she was under charter to him. The transportation company filed a cross-libel against Townsley for rent alleged to be due it from him under the charter party, which cross-libel was answered by Townsley, denying the claim made for rent, and the claimant of the ship answered the libel, denying the alleged losses and damages to the libelant. The judgment below was against the libelant's claim for damages, and in favor of that of the cross-libelant for rent. 111 Fed. 542.

The case depends upon the question whether the master and stew-

ard of the ship were the agents of its owner or of the charterer, to determine which question resort must be had to the charter-party. There were three written agreements evidencing the contract of the parties, two of which bore date June 6, 1898, and the other June 10, 1898. The second agreement of June 6th only provided for the deposit of the charter in escrow until certain advance payments required thereby had been made, and which it appears were made, and the charter delivered. The law applicable to the case is well settled. If the contract between the parties constituted a demise of the ship, which by virtue of the contract passed to the possession and control of the charterer, the master and steward became his agents, and were not the agents of the owner. On the contrary, if the agreement between the parties constituted a mere contract of affreightment, and the owner still retained possession and control of the ship, then clearly the master and steward were his agents, for whose wrongful acts he is liable. *Gracie v. Palmer*, 8 Wheat. 605, 5 L. Ed. 696; *Reed v. U. S.*, 11 Wall. 591, 20 L. Ed. 220; *Leary v. U. S.*, 14 Wall. 607, 20 L. Ed. 756; *U. S. v. Shea*, 152 U. S. 178, 14 Sup. Ct. 519, 38 L. Ed. 403. Turning to the charter party in question, we find it there declared and provided, in the first article:

"That the said party of the first part [the owner], for and in consideration of the covenants and agreements hereinafter contained on the part of the party of the second part, to be kept and performed by the said party of the second part, does hereby charter, let, and hire to the said party of the second part the whole of the steamship *Del Norte*, now lying at the port of Seattle, her tackle, apparel, furniture, machinery, appurtenances, and appliances, for the term commencing on the 6th day of June, A. D. 1898, and extending to and including the 6th day of October, A. D. 1898. Said vessel to be employed during the term of this charter party in plying between the port of Seattle, Washington, and ports, islands, and places in the territory of Alaska."

The second article provides that the vessel shall be delivered to the charterer at Seattle in good order and repair. The third article declares that the owner shall protect the vessel from all liens and claims of liens on account of debts contracted prior to the date specified for her delivery to the charterer. The fourth article specifies the rent to be paid by the charterer, and the dates, places, and manner of payments, and provides that in case of nonpayment the owner may retake possession of the vessel. It also provides for the forfeiture in that event of a specified sum to the owner as damages. The fifth article declares that should the vessel receive such damage as to disable her, by reason of which the charterer is actually deprived of her use for the purpose for which he would otherwise have used her, no charter money shall be earned during the time of such deprivation, but that the wages and sustenance of the crew shall continue to be borne by the charterer, and that:

"In the event of the loss of said steamer from any cause, or in case said vessel shall from any cause be damaged to such extent as not to be worth repairing in the opinion of the master, this charter party shall immediately cease."

By the sixth article it is provided that the charterer shall not be liable for reasonable wear and tear of the vessel or her equipment, and that all damage to the steamer arising from collision, by reason of

stranding, fire, perils of the sea, and inevitable casualties, shall be borne by the owner. The seventh article contains the agreement of the charterer to deliver to the owner the vessel and her equipment at the termination of the charter party in good order, subject, however, to the provisions of the sixth article, and also with the provision concerning the making good of any shortage in the furnishings of the vessel. By the eighth article it is declared that the charterer shall have full charge of the vessel during the continuance of the charter-party, and shall pay all bills and other expenses incurred in her operation (including the wages of the master, officers, and crew thereof), except such as are in the sixth article specifically excepted, and that all earnings of the vessel, of whatever character or description, during the term specified, shall belong to the charterer and inure to his sole benefit, and that before the ship shall be permitted to leave the port of Seattle on any voyage during the continuance of the charter party, or before she shall be permitted to leave any other port on Puget Sound which may be the point of commencement of any voyage during the continuance of the charter party, all debts contracted by the charterer for stores, supplies, or any other matter or thing whatever purchased for the use or operation of the ship, shall be fully paid, such payment to be evidenced only by a certificate to that effect signed by the master and steward of the vessel, and that the charterer shall also, prior to the beginning of any such voyage, deposit in the Puget Sound National Bank at Seattle a sum not less than \$1,500, subject to the check of C. E. Allen, the master of the vessel, as security for the payment of the crew thereof, and that, unless the crew of the vessel shall be paid within 24 hours after her arrival in port and the termination of any such voyage, the master shall have the right to check out of the bank mentioned the whole of the above-named sum, or such portion thereof as may be necessary to pay and satisfy the wages of the crew in full for such voyage. The ninth article provides that the owner shall have the naming and appointing of the master, chief engineer, and the steward of the vessel, those officers "to be in all respects under the order and direction of the second party," and shall receive from the charterer wages at not less than certain specified sums, to be paid to them at the end of each month, or at the end of the voyage, as may be agreed upon with such officers, and that in case the charterer shall be dissatisfied with the conduct of the master, chief engineer, and steward, or either of them, the owner, on receiving written notice from the charterer of such dissatisfaction and the particulars of the reason or reasons therefor, shall remove the officer so offending (if upon investigation such complaint shall be found to be justified), and shall appoint another or others in the place and stead of the one or more of said officers as shall be removed. By the tenth article the charterer agrees not to load on the vessel any cargo that will render her liable to forfeiture or fine under the laws of the United States, and that the vessel shall not, during the term of the charter party, violate any of the revenue, maritime, or shipping laws of the United States, or of any other power or government, and that, in case of any dispute arising between the master and charterer regarding the stowing of cargo or the amount of freeboard, such dispute shall be left to and determined

by a competent marine surveyor at the port at which the vessel is loading, whose decision shall be final. By the eleventh article the charterer covenants to pay, at the times and in the manner specified, the sums agreed upon, and not to assign the charter party or sublet the vessel without the written consent of the owner, and at the expiration of the charter party to deliver the vessel at the port of Seattle to the owner in as good order and condition as she now is, reasonable wear and damage by reason of the casualties mentioned in the sixth article hereof only excepted, and that, in case the charterer shall fail, neglect, or refuse to pay, at the times and in the manner specified, the sums agreed upon for the use of the vessel, or any part thereof, or shall fail to pay, at the times and in the manner specified, any of the bills or expenses of the operation of the vessel, including the wages of the master, officers, and crew thereof, or shall fail to deposit in bank for the payment of the wages of the master, officers, and crew, the sums of money agreed upon and determined, and in the manner specified, the owner shall have the right to consider the charter party forfeited, and to retake possession of the vessel, wherever she may be, with or without legal process, and that the master shall, upon receiving notice of any such default, or upon any such default coming to his notice, have the right to, and it shall be his duty, at the request of the owner, or his agent or attorney, to hold possession of the ship for and as the representative of the owner, but that no such claim of forfeiture or taking possession of the ship shall release the charterer or any security by him given from the payment of any portion of the rent agreed to be paid, or from the payment of any bills or expenses contracted in the operation of the vessel, and that, should the vessel be libeled for any matter or thing occurring subsequent to the receipt by the charterer of the possession of the ship under the charter party, he will, within 24 hours after the vessel is so taken into custody, cause her to be released by himself furnishing the necessary bond and sureties thereon for such release. By the twelfth and last article of the charter party it is provided that the vessel may be used during the continuance of the charter party for the purpose of towing barges and vessels from Puget Sound to ports, islands, and places in Alaska, but that in all cases the master shall have the right to determine the number of barges or vessels to be towed and the amount of cargo to be placed thereon, and shall have the right at any time to abandon any tow in the charge of the vessel when in his judgment the safety of the chartered ship requires it, and that no liability whatever shall attach to the owner by reason of any such abandonment; "it being understood and agreed, however, that such master is expected in all cases to use due diligence for the protection of any tow that may be placed in his charge."

By the supplemental agreement of June 10, 1898, the owner agrees that the ship may, at the option of the charterer, during the continuance of the charter party, be employed to carry freight or live stock and passengers between the west coast of Alaska and the eastern coast of Siberia, provided that safe ports must be used, and that the vessel shall not be required by the charterer to land freight or passengers at any port or place which may in any way endanger the

ship, her master to be the judge of the safety of any such landing-place, and his determination in such matter to be final and conclusive upon the parties to the agreement, in consideration of which the charterer agrees to deposit in the Puget Sound National Bank of Seattle, as security for the payment of the wages of the master, officers, and crew of the ship, the sum of \$3,000 in lieu of the sum of \$1,500 agreed upon in the charter party, said deposit to be subject to the same terms and conditions as the deposit of \$1,500 mentioned in that instrument; and the charterer for the same consideration agrees that the earnings of the ship in the trade between Alaska and Siberia shall be collected and retained by the master, who shall account therefor to the parties to the agreement, it being understood and agreed that the master shall have the right to apply such earnings, or any part thereof, to the payment of any rent due under the charter party or any debts contracted in the operation of the ship, and that, in case any such rent or any such debts be not paid by the charterer, it shall be the duty of the master to so apply the said earnings, and that the charterer will pay any additional or increased insurance premiums that may become necessary to properly protect the vessel by insurance on account of entering into the trade between Alaska and Siberia.

It is thus seen that by the contract of the parties the entire ship was let to the charterer, and the ship delivered to him, under the express and distinct agreement that he should have full charge of her; that all of the officers of the vessel, including those that it was stipulated should be appointed by the owner, should be "in all respects under the order and direction" of the charterer; and that all of the earnings of the vessel during the term, of whatever character, should belong to the charterer and inure to his sole benefit. These facts leave no room for doubt that not only the possession, but the entire control, of the ship and of all of its officers passed by the agreement of the parties from the owner to the charterer. In further confirmation of this conclusion is the covenant on the part of the charterer in the eleventh article to deliver the vessel at the expiration of the charter party to the owner at the port of Seattle in as good order and condition as she was in at the time of the agreement, reasonable wear and damage growing out of the casualties mentioned in the sixth article only excepted. As a matter of course performance of that covenant on the part of the charterer necessarily presupposed that during the life of the charter the vessel should be in the possession of the charterer.

It is contended on behalf of the appellant that the agency of the master and steward for the owner is "conclusively established" by that provision of the eleventh article of the charter party wherein it is stipulated that, for failure to pay the rent or wages agreed to be paid by the charterer, the master should, upon receiving notice of such default, at the request of the owner, take and hold possession of the vessel "for and as the representative of the party of the first part [the owner]." The correct inference to be drawn from this provision is the direct opposite of that drawn by appellant's counsel; for the provision that the master should take and hold possession of the vessel as the representative of the owner upon the happening of the specified condition necessarily implies that prior to the happening of the desig-

nated contingency he was holding possession as the representative of somebody else,—the charterer,—which is in entire accord with the other provisions of the contract.

We are of the opinion that neither the master nor the steward of the ship can be properly regarded as the agent of the owner during the life of the charter party in question, and therefore that the owner cannot be held liable for the alleged wrongful acts of its officers. These views will be found to be supported by the cases of *Gracie v. Palmer and U. S. v. Shea*, above cited; *Drinkwater v. Spartan*, Fed. Cas. No. 4,085, 1 Ware, 145; *The Aberfoyle*, Fed. Cas. No. 16, Abb. Adm. 242; *Winter v. Simonton*, Fed. Cas. No. 17,894, 3 Cranch C. C. 104; *Posey v. Scoville* (C. C.) 10 Fed. 140; *Donohoe v. Kettell*, Fed. Cas. No. 3,980, 1 Cliff. 135; *The Bombay* (D. C.) 38 Fed. 512; *American Steel Barge Co. v. Cargo of Coal* (D. C.) 107 Fed. 964.

The judgment is affirmed.

NEILSON v. CHAMPAGNE MINING & MILLING CO. et al.
(Circuit Court of Appeals, Eighth Circuit. November 10, 1902.)

No. 1,780.

1. MINING CLAIMS—EFFECT OF ENTRY—CONCLUSIVENESS AS TO THIRD PARTIES.
A stranger cannot acquire any rights in a mining claim after the application of another for a patent therefor has been allowed, and he has paid for and received a certificate of entry, which vests in him the equitable title as against third parties.
2. SAME—EFFECT OF PROTEST.
A protest filed against the issuance of a patent to a mining claim after the application for the patent has been allowed, the purchase money paid, and a certificate of entry issued does not give the protestant any basis for a suit in equity to annul the patent issued after the protest has been dismissed, or to charge the patentee as a trustee of the legal title.

Appeal from the Circuit Court of the United States for the District of Colorado.

Norman T. Mason and Darwin T. Mason, for appellant.

A. T. Gunnell, W. T. Miller, and W. J. Chinn, for appellees.

Before CALDWELL, SANBORN, and THAYER, Circuit Judges.

CALDWELL, Circuit Judge. The bill in this case seeks to have it decreed that the defendant company holds the legal title to certain lode mining claims in trust for the plaintiff, and prays that it may be required to convey the same to the plaintiff. The theory of the bill is that the plaintiff has the equitable title to certain lode mining claims, which, after due and regular proceedings had for that purpose, were entered and paid for, and afterwards patented to defendant company. The circuit court sustained a demurrer to the bill (111 Fed. 655), and the plaintiff appealed.

The material facts disclosed by the bill essential to be considered in deciding the case are: That the defendant company, the Champagne Mining & Milling Company, in April, 1896, was the owner of four lode mining claims, known as Deadwood No. 1, Deadwood No.

2, Deadwood No. 3, and Deadwood No. 4, and on the 25th day of April of that year filed its application for a patent for the same, and published and posted the notice of such application required by law. To this application for a patent adverse claims and protests were filed, but neither an adverse nor protest was at that time filed by the plaintiff in this suit or any one by or under whom he claims. The several adverse claims and protests prevented the defendant company's application for a patent being passed to entry until the 18th day of February, 1899, when the defendant company was adjudged to have the right to enter the mining claims under its application for a patent, and thereupon on that day it paid the receiver of the proper land office the purchase money for the same, and received the usual receiver's certificate of entry therefor, being mineral entry No. 1,957, upon which a patent was afterwards duly issued and delivered to the defendant company.

The averments of the bill upon which the plaintiff relies to sustain his contention that the defendant company holds the legal title thus acquired to these lode mining claims in trust for the plaintiff, to whom it should be required to convey them, are: That on May 1, 1899, the plaintiff discovered lodes or veins in rock bearing gold on these several lode mining claims, and that he sunk discovery shafts and did all other things essential to the valid location of lode mining claims under the law; and that on June 9, 1899, he filed in the proper land office his "protest" against the issuance of a patent to the defendant company under its entry, and on June 16, 1899, an additional protest, and on June 29, 1899, an amended protest. These several protests alleged, in substance, that the defendant company had, prior to its entry of these mining claims, to wit, during the years 1897 and 1898, failed to make the annual expenditure of \$100 in labor or improvements thereon required by section 2324 of the Revised Statutes of the United States [U. S. Comp. St. 1901, p. 1426], and had also failed to expend thereon \$2,000 in labor and improvements prior to the date of the defendant company's entry. These protests, with the accompanying affidavits, were by the local land officers transmitted to the commissioner of the general land office, by whom they were dismissed, and, on appeal to the secretary of the interior, this ruling was, on February 12, 1900, affirmed, in a very clear and satisfactory opinion, made part of the plaintiff's bill.

The plaintiff did not adverse the defendant company's application for a patent, and did not file his protest against the issuance of a patent, until after the defendant company, at the end of a long litigation in the land department with others, had been adjudged to be the rightful owner of the mining claims, and entitled to enter the same and to receive a patent therefor, and had paid the entrance price and received a certificate of entry.

The first question that we find it necessary to consider is what rights, if any, the plaintiff acquired by protesting against the issuance of a patent to the defendant company under its entry. This question was fully considered by Mr. Justice Brewer while circuit judge of this circuit in the case of *Wight v. Du Bois* (C. C.) 21 Fed. 693, 696. Referring to and construing the statute, the learned judge said:

"It becomes necessary to see what rights this last clause gives. I think all that it covers is the right to anybody to come in and enter his protest or objection; in other words, to say to the officers of the government that the applicant has not complied with the terms of the statute, and to insist that there shall be an examination by such officers to see if the terms have in fact been complied with. He does not appear as a party asserting his own rights; but if we may, so to speak, parallel these proceedings with those in a court, such an objector appears as an *amicus curiæ*,—a friend of the court,—to suggest that there has been error, and that the proceedings be stayed until further examination can be had. Such a protest does not bring the protestant into court for the assertion of his own title or rights; does not revivify rights lost by a failure to adverse. True, if the protest or objection is sustained, the proceedings will be set aside, new ones must be commenced, and then the objector may be in a position to assert his rights; but if the protest or objection be not sustained the objector, like an *amicus curiæ*, has nothing more to say in the matter. In other words, the right to protest is not the right to contest. The latter is lost by the failure to adverse. The former remains open to every one, holders of adverse claims as well as others. But the protest is only to the officers of the government, challenges only the applicant's claims, and in no manner brings up for consideration any claims of the protestant. Such a protest can be made only before the land department, and, if there rejected, the protestant has no further standing to be heard anywhere. The protest cannot be made the basis of any litigation in the courts, for the courts are only open to those who have rights to assert; they sit for the determination of controversies. They do not, at the instance of strangers, review the regularity of proceedings between parties who are competent to determine such regularity, and who do not themselves invite any judicial determination."

It is well settled that when the purchase price is paid for government land to the local land office authorized to receive the same and allow the entry, and a certificate of purchase is issued to the purchaser, the right to a patent immediately attaches, and when the patent is subsequently issued it relates back to the inception of the right of the patentee. The certificate of entry invests the purchaser with the full equitable title to the land, and so far as the acquisition of title after that by any other person is concerned is equivalent to a patent. *Deffebach v. Hawke*, 115 U. S. 392, 6 Sup. Ct. 95, 29 L. Ed. 423; *Benson Mining & Smelting Co. v. Alta Mining & Smelting Co.*, 145 U. S. 428, 12 Sup. Ct. 877, 36 L. Ed. 762; *Calhoun Gold Min. Co. v. Ajax Gold Min. Co.*, 182 U. S. 499, 21 Sup. Ct. 885, 45 L. Ed. 1200.

This court, following the well-settled rule on the subject, has held that one who has not acquired a right to government land before its sale by the government cannot, after its sale, maintain a suit in equity to charge the purchaser of the land from the United States with a trust in his favor, upon the ground that the United States sold it to the purchaser through an error of law. *Hartman v. Warren*, 76 Fed. 157, 22 C. C. A. 30.

When the certificate of entry was issued to the defendant company the plaintiff was an entire stranger to the proceedings. He neither had nor claimed to have any kind of right or interest in and to these mining claims. He had taken no step to initiate a right or claim to them, and after the government had parted with its title to them it was too late for him to do so. It was not until after the defendant company had been adjudged to have the right to enter the land, and the entrance money had been paid and a certificate of entry issued, that the plaintiff filed his protest against the issuance of a patent to the

defendant company. Granting that a stranger may "protest" against the issue of a patent, he acquires thereby no right or equity in the land which can be made the basis of an equity suit to annul the patent or to charge the patentee as a trustee of the legal title for the protestant.

At the time the defendant company made application for a patent and at the time it paid for and received the certificate of entry for the mining claims the plaintiff does not claim to have done anything to invest him with any right or claim to the land. Previous to the time the defendant company paid the entrance money for the land and received the certificate of purchase, all the adverse claims and protests that had been filed against the issuance of a patent to the defendant company had been dismissed by the land department. The only parties, therefore, having any concern with or interest in the entry at the time it was made were the United States as the owner of the land, and the defendant company as the purchaser; and if the United States was satisfied of the right of the defendant company to purchase the land, and sold and conveyed it to the defendant company accordingly, no one not then having any right, claim, or equity in the land, but whose relation was that of a total stranger to the proceeding, can afterwards assume the role of guardian for the government, and by a mere protest invoke the aid of a court of equity to set aside and annul its conveyance for alleged errors and mistakes which in no manner affect any right of the protestant existing at the time of the sale, and after the sale and conveyance it was too late to initiate or acquire any such right.

The decree of the circuit court is affirmed.

ELTONHEAD v. ALLEN et al.

(Circuit Court of Appeals, Third Circuit. December 16, 1902.)

No. 9.

1. JURISDICTION—ATTACHMENT—PRELIMINARY AFFIDAVIT—PRESUMPTION.

Where a state court of general jurisdiction is authorized to issue a writ of attachment of land on the filing by the applicant, before the sealing of the writ, of an affidavit averring that defendant is a nonresident of the state, and that he owes plaintiff a specified sum, but the affidavit is not required to be placed upon record, it will be conclusively presumed, in favor of jurisdiction, that the affidavit was made as required, though the record is silent with respect to it; and the judgment of the court decreeing the sale of the land will be valid.

2. SAME—RECORD—SUFFICIENCY.

A record in attachment proceedings recited: "Writ issued and sealed August 12, 1862. Amount specified in affidavit, thirteen hundred and sixty-six dollars and sixty-seven cents." The statute regulating attachment proceedings required that the applicant for the writ should, before the sealing thereof, make oath to the effect that defendant was a nonresident of the state, and that he owed plaintiff a specified sum. *Held*, that the fact of the making of the affidavit before the sealing of the writ sufficiently appeared from the record.

In Error to the Circuit Court of the United States for the District of New Jersey.

Geo. W. Macpherson and D. J. Pancoast, for plaintiff in error.
Clarence L. Cole, for defendants in error.
Before ACHESON, DALLAS, and GRAY, Circuit Judges.

DALLAS, Circuit Judge. Upon the trial of an action of ejectment to recover possession of certain real estate in Atlantic City, N. J., the learned judge of the circuit court instructed the jury that their verdict must be for the defendants. Such verdict was accordingly rendered, and the judgment entered thereon is now before this court for review. Several questions which have been debated by counsel need not be discussed by us, for our decision may and will be rested upon a single point, which we deem to be determinative.

If the attachment proceedings in the state court of New Jersey, and the order therein, together with the sale and deed of conveyance made in pursuance thereof to John F. Bennet, vested the title to the premises in question in the said Bennet, predecessor in title of the defendants, then the judgment of the circuit court was clearly right. But it is contended that said deed did not, in law, transfer the title to Bennet, because, as is asserted, it does not appear from the copy of the record in the attachment proceeding, adduced on the trial below, that the court in which that proceeding was instituted and prosecuted had jurisdiction to entertain it and to pronounce judgment therein. The ground mainly relied upon to maintain this position, and the only one, we think, which affords it any semblance of support, is that the record to which we have referred does not sufficiently disclose that the applicant for the attachment had complied with the provision of the New Jersey statute that:

"The applicant for such writ of attachment shall, before the sealing thereof, make oath or affirmation (which shall be filed in the office of the clerk of the court out of which the same shall be issued) before any judge or justice aforesaid, that the person against whose estate such attachment is to be issued, is not, to his knowledge or belief, resident at that time in this state, and that he owes the plaintiff a certain sum of money, specifying as nearly as he can, the amount of the debt or balance."

If, in fact, the record of the proceeding under consideration had been silent as respects the filing of the oath or affirmation required by the provision above quoted, we are of opinion that the circuit court should have conclusively presumed that that preliminary fact necessary to set the machinery of the law in motion had appeared to the satisfaction of the court whose authority to act depended upon its existence. *Noble v. Railroad Co.*, 147 U. S. 165, 13 Sup. Ct. 271, 37 L. Ed. 123. The case of *Voorhees v. Jackson*, 10 Pet. 469, 9 L. Ed. 490, was decided upon a writ of error to the judgment of a circuit court in an action of ejectment. The question was as to the validity of a sale of the premises in controversy, under a judgment of a court of common pleas of Ohio, in a case of foreign attachment; and it was objected to the validity of the sale that, although the statute of Ohio provided "that an affidavit shall be made and filed with the clerk, before the writ issues, and if this is not done the writ shall be quashed on motion," yet no such affidavit was found

in the record. In that case, as in this, the law did not prescribe what should be deemed evidence of the making and filing of the affidavit, nor that it should appear on the record; and the supreme court said:

"This leaves the question open to the application of those general principles of law by which the validity of sales made under judicial process must be tested, in the ascertainment of which we do not think it necessary to examine the record in the attachment for evidence that the acts alleged to have been omitted appear therein to have been done. Assuming the contrary to be the case, the merits of the present controversy are narrowed to the single question whether this omission invalidates the sale. The several courts of common pleas of Ohio at the time of these proceedings were courts of general civil jurisdiction, to which was added, by the act of 1805, power to issue writs of attachment and order a sale of the property attached on certain conditions. No objection, therefore, can be made to their jurisdiction over the case, the cause of action, or the property attached. The process which they adopted was the same as prescribed by the law. They ordered a sale, which was executed, and, on the return thereof, gave it their confirmation. This was the judgment of a court of competent jurisdiction on all the acts preceding the sale, affirming their validity in the same manner as their judgment had affirmed the existence of a debt. There is no principle of law better settled than that every act of a court of competent jurisdiction shall be presumed to have been rightly done, till the contrary appears. This rule applies as well to every judgment or decree rendered in the various stages of their proceedings, from the initiation to their completion, as to their adjudication that the plaintiff has a right of action. Every matter adjudicated becomes a part of their record, which thenceforth proves itself, without referring to the evidence on which it has been adjudged."

There is much more in this opinion which is pertinent to the case in hand, but it is unnecessary to quote further. Its purport and effect as a whole are sufficiently shown by the foregoing extract; and the decision founded upon it has never, so far as careful search has enabled us to discover, been departed from or modified. On the contrary, it was referred to in the comparatively recent case of *Applegate v. Mining Co.*, 117 U. S. 269, 6 Sup. Ct. 742, 29 L. Ed. 892, as authority for the proposition that, where a court of general jurisdiction is acting under special statutory authority, the steps pointed out by the statute, though necessary to be taken, need not appear in the record, unless the statute expressly or by implication requires it, and that every presumption not inconsistent with the record is to be indulged in favor of the court's jurisdiction. Indeed, it is to be presumed, in respect to official action generally, that all statutory prerequisites thereto had been complied with; for "it is a rule of very general application that, where an act is done or can be done legally only after the performance of some prior act, proof of the later carries with it a presumption of the due performance of the prior act"; and, as we have seen, the acts of courts are not to be especially denied the benefit of this presumption in favor of legality. *Nofire v. U. S.*, 164 U. S. 660, 17 Sup. Ct. 212, 41 L. Ed. 588. From these several adjudications of the supreme court, it seems plainly to result that, for this court at least, the law must be regarded as settled in accordance with the presentation of it to be found in the fourth edition of *Freeman on the Law of Judgments* (sections 124 and 132), as follows:

"If a statute required a certain affidavit to be filed or a certain fact to be found prior to the rendition of judgment, it will be presumed, in the absence

of any statement or showing upon the subject, that such affidavit was filed or such fact found. * * * The authorities, however, all concede that the mere fact that the record is silent respecting the existence of some jurisdictional fact cannot create the presumption that such fact did not exist. On the contrary, its existence will be presumed. The only question is whether the presumption may be overcome by extrinsic evidence. The preponderance of the decisions upon this question supports the doctrine that it is a matter of no consequence whether the jurisdiction of the court affirmatively appears upon the judgment roll or not; for, if it does not, it will be conclusively presumed."

These statements are further supported, more or less directly, by the several cases cited below; and we need not look beyond the case before us for exemplification of the justice of the rule which they denote, for nothing could be more manifest than the injustice of invalidating a title to real estate, founded upon the judgment of a competent court, pronounced nearly 40 years ago, merely because the filing of an affidavit, not required to be set out in the record, and which, of course, may have disappeared from the files, cannot at this late day be established otherwise than by legal presumption, aided as will presently be seen, by a corroborative, though incidental, reference to it on the face of the record itself. *Beattie v. Wilkinson* (C. C.) 36 Fed. 546; *Foster v. Givens*, 67 Fed. 684, 14 C. C. A. 625; *McMurray's Heirs v. City of Erie*, 59 Pa. 226; *Newcomb's Ex'rs v. Newcomb*, 13 Bush, 544, 26 Am. Rep. 222; *Dean v. Thatcher*, 32 N. J. Law, 470; *Schneider v. Marinelli*, 62 N. J. Law, 740, 42 Atl. 1077; *Otis v. The Rio Grande*, Fed. Cas. No. 10,613 [1 Woods, 279]; *Colton v. Beardsley*, 38 Barb. 29, 51; *Ex parte Sternes*, 77 Cal. 156, 19 Pac. 275, 11 Am. St. Rep. 251.

But apart from and independently of the broad question which has thus far been considered, we are of opinion that this case was properly decided in the court below, for the attachment record which was before the court is not silent respecting the making and filing of the statutory affidavit. Its first statement is in these words: "Writ issued and sealed August 12, 1862. Amount specified in affidavit thirteen hundred and sixty-six dollars and sixty-seven cents." There is no ground for supposing that the affidavit here alluded to was not the affidavit required by law. The legal implication is that it was, and this implication accords with the natural significance of the terms of the entry itself, which clearly indicate that it was the particular affidavit, "specifying * * * the amount of the debt," which the act provided should be made before the sealing of the writ. This understanding, and no other, is consistent with the rest of the record, and with the regularity of the proceedings to which it relates. We have no doubt of its correctness, and therefore hold that, even if it were necessary that the making of the prescribed oath or affirmation should appear by the record, that fact would sufficiently appear from the entry to which we have referred.

Having now stated the grounds upon which we base our conclusion upon the question which, as we have said, we regard as determinative, it remains but to say, as to the whole case, that we have not been convinced that any error whatever was committed by the trial judge, and accordingly the judgment of the circuit court is affirmed.

CLARK v. BROWN.

(Circuit Court of Appeals, Eighth Circuit. November 26, 1902.)

No. 1,715.

1. RECEIVERS—APPOINTMENT—VALIDITY OF ORDER.

Where the appointment of a receiver depends on whether the bill contains allegations justifying equitable cognizance, an order appointing the receiver is not void, though the determination of the sufficiency of the bill was erroneous.

2. SAME—PLEADING.

Where a bill alleged that complainant was entitled to one-half of a crop of flax, and that defendant was engaged in removing the entire crop beyond the jurisdiction of the court and disposing of it, and that the party liable to plaintiff on the contract was insolvent, the bill was sufficient to warrant the appointment of a receiver to take possession of and preserve the crop pending the litigation.

3. SAME.

Where a bill for the appointment of a receiver alleged that plaintiff was entitled to one-half of the proceeds of a crop of flax, and that defendant was engaged in removing the entire crop beyond the jurisdiction of the court, and disposing of it while the party liable to complainant on the contract was insolvent, an answer merely alleging that defendant was willing to pay complainant what the court should find him entitled to on a contract with another for a sale of the land, if complainant would execute to defendant a warranty deed of the land, was irrelevant, and insufficient to prevent the appointment of the receiver.

4. SAME.

An order appointing a receiver is not invalidated by reason of the fact that the amended bill was not verified, where no objection on that ground was taken at the time.

5. SAME—PRIOR APPEAL—OBJECTIONS—FAILURE TO URGE FACT.

Where a prior appeal was taken in an action in which a receiver was appointed, and no objection was made thereon to such appointment, no objection to the propriety or regularity of such appointment could be made on a subsequent appeal.

6. SAME—FUNDS IN RECEIVER'S HANDS—INTEREST.

Where it was determined on appeal that the appointment of a receiver at complainant's instance was erroneous, defendant is not entitled to recover from complainant interest on funds held by the receiver pending the litigation, such funds being in the custody of the court.

7. COMPENSATION OF RECEIVER—PAYMENT FROM ESTATE.

Where the appointment of a receiver was proper when made, and defendant throughout the proceedings acquiesced in the receivership, and such receiver was efficient in caring for and disposing of the property, obtaining therefor much more than would have been obtained by defendant, his compensation should be paid from the proceeds, though it was subsequently determined that his appointment was erroneous.

Sanborn, Circuit Judge, dissenting.

Appeal from the Circuit Court of the United States for the District of North Dakota.

This was a suit in equity, wherein, upon the facts alleged in the bill as amended, the complainant, Anheier, as receiver of the Citizens' National Bank of Fargo, claimed to be entitled to one-half of a crop of flax raised by the defendant, Clark (appellant), in the season of 1898, upon a specified section of land in North Dakota. The facts upon which that claim was based are

fully stated in *Clark v. Anheier*, 45 C. C. A. 599, 106 Fed. 754, and need not be repeated here. Upon allegations that the defendant was, at the time of filing the bill, engaged in threshing the crop of flax, and removing it from that state and disposing of it, and tending to show that the complainant's rights would be thereby lost, and on hearing upon an order to show cause, the court appointed Mr. H. W. Geary receiver of said crop of flax, with directions to take possession of the same, and thresh such part as remained unthreshed, and care for, protect, and preserve the crop, including the proceeds of such part of the crop as had been sold, which proceeds the defendant was required to turn over to him, and to act thereafter under the orders and directions of the court. The net proceeds of so much of the flax as the defendant had disposed of by sale were by him turned over to the receiver, who proceeded to cause the unthreshed portion of the crop to be threshed and placed in elevators, and finally caused all the unsold flax to be moved to and placed in an elevator at Duluth, Minn., and paid out and expended about the same considerable sums of money for threshing, elevator charges, freight charges, insurance, interest on money advanced by the Duluth Elevator Company to pay previous charges against the flax, and for necessary incidental outlays and expenses. Decree was entered in said cause January 12, 1900, adjudging that there was owing from the defendant to complainant the value of half said crop of flax, \$3,205.50, and interest since December 24, 1898, making \$3,519.03, and costs taxed at \$419.55, and directing the sale of said flax by H. W. Geary, as master. On January 30, 1900, the solicitors for the complainant and defendant entered into a written stipulation that the receiver should immediately sell said flax at private sale for the highest market price attainable, and convert the same into money, and hold \$5,000 in lieu of the flax until the final determination of the cause on appeal, and subject to the final decree, and pay the balance immediately to the defendant's solicitors. The stipulation recited that the receiver had been appointed "over the objection and opposition of the defendant," and that the stipulation should not prejudice the right of the defendant to a review upon appeal of the order of the circuit court appointing the receiver, nor any claim for damages he might have against complainant by reason of the appointment of the receiver or the taking of the flax. And the court thereupon made its order in conformity with that stipulation, and the flax was sold, and the money disposed of by the receiver, in accordance with the terms of said stipulation and order. Upon appeal this court reviewed the proofs in the cause, and held that the complainant had failed to establish any right to or interest in the 1898 crop of flax as against the defendant, and reversed said decree of the circuit court, with instructions to enter a decree dismissing the bill for want of equity. After the filing of the mandate, the receiver rendered his final report, accounting for the moneys received by him, and his expenditures, outlays, and charges. The defendant excepted to certain items of expenditures in part as excessive and greater than the cost would have been to the defendant had there been no receiver, and to other items as improper and unwarranted, and also claimed, as against the complainant, interest on moneys while in the hands of the receiver. Testimony was taken, and the court sustained some of the exceptions wholly or in part, and overruled others, and the claim for interest. This appeal from the final decree rendered brings up for review only questions as to the propriety of the rulings of the court upon these exceptions to the report of the receiver. After the entry of the decree, the appellee, Edwin F. Brown, having succeeded the original complainant as receiver of the Citizens' National Bank of Fargo, was duly substituted as complainant in the cause.

Seth Newman (Burleigh F. Spalding and Winfield S. Stambaugh, on the brief), for appellant.

V. R. Lovell (John D. Benton and Daniel B. Holt, on the brief), for appellee.

Before SANBORN and THAYER, Circuit Judges, and LOCHREN, District Judge.

LOCHREN, District Judge, after stating the case as above, delivered the opinion of the court.

Counsel for appellant, in their brief, assert and reiterate, as the principal ground for sustaining all of their assignments of error, that "the order appointing the receiver was void," and therefore the defendant was at all times entitled to a return to him of the property intact, and undiminished by any expense of the receivership, because, they say, "the bill contains no allegation justifying equitable cognizance." But whether it did or did not was a question to be determined by the court, and its adjudication, even if erroneous, was not void. *Mellen v. Iron Works*, 131 U. S. 352, 367, 9 Sup. Ct. 781, 33 L. Ed. 178. The bill, however, contained ample averments to invoke equitable relief, and warrant the appointment of a receiver, in its allegations that the complainant was entitled to one-half of the crop of flax, and that defendant was engaged in removing the whole beyond the jurisdiction of the court, and disposing of it, while the party liable to the complainant on contract was insolvent. High, Rec. § 9. Moreover, notwithstanding the recital in the stipulation for the sale of the flax by the receiver that he had been appointed "over the objection and opposition of the defendant," it fully appears from the record that, while defendant did not directly consent to the appointment, he made no objection to it having color of seriousness or force. His answer to the order to show cause why a receiver should not be appointed was irrelevant. It was merely a statement that he was willing to pay complainant what the court should find him entitled to on a contract with another for sale of the land, if complainant would execute to defendant a warranty deed of the land. This in no way met the allegations of the bill on which the right to the appointment was claimed. That the amended bill was not verified was an irregularity which might have defeated the application at the time, had it been called to the attention of the court. But no objection on that or any other ground was made. Defendant answered the amended bill, and never made any motion to have the appointment revoked or the receiver discharged. And although, in the stipulation mentioned, it was recited that it should be "without prejudice to the right of said defendant to a review upon appeal of the order of the circuit court appointing said receiver," it appears from the assignment of errors on the appeal which followed to this court, and which are set forth in the present record, that no question was raised or presented on that appeal as to the appointment of the receiver. As the appointment of the receiver was a proceeding in the cause prior to that appeal, the failure to question it upon that appeal was an acquiescence in the receivership, and no dispute as to the propriety or regularity of the appointment when made could afterwards be considered. As before stated, the decision of this court upon that appeal did not rest upon the sufficiency or insufficiency of the averments of the bill, but on a determination of the merits of the cause as disclosed by the proofs.

The defendant was not entitled to interest on the money for which the property was sold during the time that money was held by the receiver. The money in the hands of the receiver was in the custody of the court (*Radford v. Folsom*, 55 Iowa, 276, 7 N. W. 604), and it

was held by the receiver in accordance with defendant's written stipulation that it should be so held.

The amount of compensation to be allowed a receiver for services and expenditures, and whether the same should be paid from the fund accumulated in the receivership or charged in whole or in part to the party who procured the appointment are matters to be determined upon equitable considerations. Here the appointment of the receiver was proper, when made. No showing to the contrary was attempted by the defendant, whose proceedings and conduct showed acquiescence in the receivership throughout. The receiver acted honestly, prudently, and efficiently in caring for the property, preparing it for market, removing it to a better market in season to avoid a considerable charge of taxes, and in the sale of the property; realizing, as the court found, after the deduction of all of his charges and claims for compensation, a much larger sum than would have been obtained by the defendant had he sold the property as he had purposed when stopped by the receivership. No reason appears why the receiver's fair compensation and just expenditures should not be paid from the fund obtained from the sale of the property, the value of which and amount realized was so increased by his services and expenditures, instead of being charged to the complainant, even though the latter failed to recover in the suit. High, Rec. § 796; Hembree v. Dawson, 18 Or., 474, 23 Pac. 264; Jaffray v. Raab, 72 Iowa, 335, 33 N. W. 337. The defendant was not damaged, but actually benefited, by the receivership, and the court modified, reduced, and disallowed the receiver's charges to as great an extent as the evidence warranted.

The decree appealed from is affirmed, with costs.

SANBORN, Circuit Judge (dissenting). It is conceded that the defendant in this case is not entitled to recover of the receiver appointed by the court the interest on the \$5,000, the proceeds of the flax, from February 1, 1900, to June 1, 1901, the time during which he kept this money in his control. That, however, is not the question presented by this case. This is an appeal from a judgment of taxation of costs against the complainant. The defendant below (the appellant here) claims that he is entitled to recover against the complainant, as costs, the damages which he suffered by the detention by the receiver of this \$5,000 from February 1, 1900, to June 1, 1901. The complainant brought a bill in equity, and caused this receiver to be appointed, and caused the flax to be taken into his possession, against the will and over the objection of the defendant. After this had been done, the defendant stipulated with the plaintiff, "reserving all of his rights and waiving none whatsoever by this stipulation," that the receiver might sell the flax at private sale for \$5,000, and might hold the money in lieu of the flax until the final determination of the action, "without prejudice to any claim for damages or otherwise that the defendant might have against the complainant by reason of the appointment of said receiver or the taking of said flax." The final determination of the action was that the complainant never had any cause of action against the defendant, or any right to the appointment of the receiver, and his bill was dismissed. The defendant then pre-

sented his items of costs and damages against the complainant, among which was the item for interest upon the \$5,000 during the one year and four months that it had been held by the receiver by reason of the wrongful commencement and maintenance of the action by the complainant. In my opinion, the amount of interest upon this \$5,000 at the legal rate for the time that it was thus detained by the action of the complainant is the proper measure of damages for that detention for which the complainant is liable, and against whom it should be taxed in this action. The defendant is entitled to recover of the complainant all the damages which he sustained by the wrongful taking of the flax by the receiver on the complaint of the plaintiff. If the flax had been held without sale, the defendant would have been entitled to recover the value of the flax and the value of its use during the time it was detained by the receiver. When it was sold, and converted into money, the defendant was entitled to that money. The wrongful maintenance of the action for a year and four months after the money was obtained by the receiver deprived the defendant of the interest upon it during that time, and this amount should, in my opinion be taxed against the complainant, and recovered by the defendant in this action.

2. The appellant has made a motion that the appellee be required to pay the costs of printing the portions of the record which he designated on the ground that they were irrelevant to the issues presented to this court. These portions of the record consist of inspectors' and weighmasters' certificates (folios 72 to 94, record), the designation of parts of the record to be printed on the original appeal (folios 160 to 163), and the appellant's assignment of errors on the original appeal. The motion of the appellant in this behalf should be granted, because none of the matters here specified relate in any way to the issues presented upon this appeal.

TRINIDAD ASPHALT MFG. CO. v. TRINIDAD ASPHALT REFINING CO.
(Circuit Court of Appeals, Eighth Circuit. November 26, 1902.)

No. 1,714.

1. SALES—REFUSAL TO FILL ORDERS—ACTION FOR DAMAGES—EVIDENCE—ADMISSIBILITY.

A contract for the sale of asphalt and cement contained stipulations binding the buyer to use the goods exclusively in its own trade and for roofs and sidewalks, and authorized the seller to cancel it in case the buyer should sell or use the same other than as so provided. The buyer claimed damages arising from the seller's cancellation of the contract and refusal to fill orders. *Held*, that testimony as to whether the seller knew that the buyer was handling other asphalts was irrelevant.

2. SAME.

Since the contract merely required the seller to furnish to the buyer the materials designated for the latter's exclusive use in its own trade, and did not permit the buyer to make contracts with third parties, and require the seller to fill them, the court properly allowed a witness for the buyer to be asked on cross-examination if he did not know, when he made a contract with a third party, that the buyer's contract with the seller had about expired, as the answer might have a bearing on the orders for materials for the nondelivery of which the buyer claimed damages.

3. SAME—BREACH OF STIPULATION—DEFENSE.

The fact that a seller was anxious to be relieved from a contract requiring it to sell materials did not furnish the buyer an excuse for committing a breach of the stipulation binding it to use the materials so purchased exclusively in its own trade.

4. SAME—EVIDENCE—ADMISSIBILITY.

Since it was competent for the seller to show that materials ordered by the buyer, for the nondelivery of which the buyer claimed damages, were not ordered in good faith for the buyer's exclusive use, as required by its contract, but to fill contracts made with third parties, the admission in evidence of a contract between the buyer and a third party, whereby the former agreed to furnish materials to the latter, was proper.

5. SAME—DAMAGES FOR NONDELIVERY.

Where a buyer was bound by the contract to use the materials purchased exclusively in its own trade, it could not recover damages for the seller's failure to fill orders for materials intended in whole or in part for delivery to third parties pursuant to contracts made with them, whether the seller knew or did not know of such contracts.

6. SAME—EVIDENCE—SUFFICIENCY.

Evidence in an action on a written contract for the price of materials sold under it held sufficient to warrant the jury in finding that a part of the materials ordered, and for the nondelivery of which the buyer claimed damages by way of a counterclaim, were, when so ordered, intended for delivery to a third party, pursuant to a contract previously entered into between the buyer and the third party.

In Error to the Circuit Court of the United States for the Eastern District of Missouri.

The defendant in error, a New Jersey corporation, brought this action against the plaintiff in error, a corporation of the state of Missouri, to recover the contract price for specified quantities of different preparations or products of Trinidad asphalt, alleged to have been consigned and delivered by the plaintiff to the defendant on defendant's orders and under a contract in writing between the parties entered into April 8, 1899, which is set forth in full in the petition. By the terms of said contract, which was to continue for three years, the plaintiff agreed to sell and deliver to defendant, free on board cars or boat at Jones Point, N. Y., on terms and conditions stated, all refined Trinidad asphalt, Trinidad asphalt roofing cement, Trinidad asphalt paving cement, and still cleanings which the defendant company might require during the existence of the contract, except that plaintiff should not be obliged to sell more still cleanings than was produced in the regular course of its business. A more particular description of the commodities, and the prices for each, and the times and manner of payments, and provisions for interest in certain cases, and for discount in a specified case were stated. By the fifth subdivision of the contract the defendant agreed to use the Trinidad asphalt and Trinidad cement purchased under the contract exclusively in its own trade, and for the purpose of manufacturing and repairing roofs and laying and repairing sidewalks, and agreed "not to dispose of the same or use, or, to its knowledge, permit it to be used or disposed of, for any other object or purpose whatsoever." By the sixth subdivision of the contract it was provided that, in case the defendant should sell or use or dispose of Trinidad asphalt or Trinidad cement other than as provided in the contract, or otherwise neglect or refuse to comply with its terms and conditions, the plaintiff should have the right to cancel the contract upon 10 days' written notice delivered or mailed to defendant at its usual place of business at St. Louis, and that on the expiration of such notice the contract should absolutely cease and be determined, saving causes of action which either party might claim against the other. Plaintiff claimed to recover the sum of \$2,687.65, with specified interest on smaller sums making up that amount from different dates when such smaller sums became payable. Defendant's answer admitted the incorporation of each of the parties, and the making of the written contract set forth in the petition, and controverted the other

allegations of fact in the petition by a general denial. It also, by way of counterclaim, alleged that on or about April 18, 1900, plaintiff notified defendant that it would deliver no more merchandise under said contract; that defendant has duly performed all the conditions of said contract on its part, but that plaintiff has failed to perform its part of said contract, and on and after said last-named date refused and refuses to deliver to defendant any of the material provided for in said contract and required by defendant, including 5,500 tons of refined Trinidad asphalt and 500 tons of Trinidad asphalt roofing cement, although plaintiff had duly accepted defendant's orders for 1,000 tons of said refined Trinidad asphalt; and that defendant was ready to receive and pay for all the goods so ordered, and has been damaged by plaintiff's refusal to deliver the same in the sum of \$30,000; for which judgment is prayed, with interest and costs. Plaintiff replied to this counterclaim—First. By a general denial of each and every allegation therein contained. Second. By averments that defendant from time to time under said contract purchased Trinidad asphalt and Trinidad cement, but did not use the same exclusively in its own trade and for the purpose of manufacturing and repairing roofs and laying and repairing sidewalks, but used such material and disposed of the same for paving purposes to the authorities of Chicago, Kansas City, Cincinnati, and Cleveland, and to other corporations, business and municipal, knowing that the material so sold and disposed of would be used for paving purposes; that this was done secretly, without plaintiff's consent or knowledge; and plaintiff, on discovering the same, exercised its right and election to cancel the contract, and gave 10 days' written notice thereof to defendant by mail, prepaid, addressed to defendant's usual place of business in St. Louis; and that on the expiration of such 10 days the contract ceased; that all orders mentioned in said counterclaim were placed with plaintiff after plaintiff had discovered such violation of the contract by defendant, and when defendant had no right to place such orders. It denied all damage to defendant. At the commencement of the trial it was conceded that plaintiff was entitled to recover or be allowed the amount claimed by it in its petition, and that the only issue to be tried was that involving defendant's counterclaim. At the close of the trial the jury returned the following verdict: "We, the jury, find the issues for plaintiff, and assess its damages at the sum of \$2,839.74."—signed by the foreman; and for this amount, with costs, judgment was duly entered in favor of the plaintiff.

W. B. Homer, for plaintiff in error.

Adiel Sherwood, for defendant in error.

Before SANBORN and THAYER, Circuit Judges, and LOCHREN, District Judge.

LOCHREN, District Judge, after stating the case as above, delivered the opinion of the court.

The issues in this case were of fact only, and are settled by the verdict of the jury. The assignments of error present for our consideration only certain exceptions taken to rulings of the court in respect to the admission of testimony, and to portions of the charge as given to the jury, and to one refusal to charge as requested.

1. The court correctly ruled that the question to defendant's witness Terpening whether, to his knowledge, the officers of plaintiff company knew that defendant company was handling other asphalts, called for irrelevant testimony. The defendant's right to handle other asphalts was unquestioned, and whether or not plaintiff's officers knew it did so was immaterial.

2. There was no error in allowing the same witness to be asked, on cross-examination, if he did not know, when he made the contract with the Ayreult firm at Tonawanda, that their contract with plain-

tiff company had about expired. The court correctly held that, while the contract required plaintiff to sell and deliver to defendant material of the kinds designated to be used exclusively in its own trade and for the purposes stated, it did not permit defendant, by making contracts with other like companies throughout the country, to require the plaintiff to supply all such companies under its contract with defendant. The question called for an answer which might have a bearing on the propriety of some of the orders for material sent to plaintiff, in respect to which defendant claimed damages.

3. The question asked the same witness on cross-examination respecting the mixture which defendant, after cancellation of the contract, had been selling the city for paving purposes, was within the fair limits of cross-examination of this interested witness. It might lead to a comparison of that material with what had been previously sold to the city. It did not call forth any answer to defendant's prejudice.

4. The questions asked of the witness Reid were properly excluded. It was no excuse for defendant's breach of the contract that plaintiff was anxious to be relieved from it.

5. In view of the testimony of the witness Reddick in respect to the furnishing by defendant of Trinidad cement to the city for paving, it was not improper to show that his own like act was with permission of plaintiff, with whom he had a like contract.

6. The questions and answers covered by the sixth assignment of error occurred in an unobjectionable attempt to explain the differential characteristics of two kinds of asphalt commodities. There was little success in the attempt, and no harm to either party.

7. That part of the deposition of the witness Liesak ruled out was irrelevant. There was no attempt to show that the cement which defendant was charged with having sold to the city was what was described in the contract or by any one as "paving cement."

8. That part of the deposition of the witness Boorm stating the prices at which he was directed by the president of the Alcatraz Paving Company to sell material was plainly incompetent, and properly excluded.

9. The agreement of December 30, 1899, between the defendant and the National Roofing Company, of Tonawanda, was properly admitted in evidence. The contract made by the parties to this action is admitted by the pleadings. The fifth subdivision limits the plaintiff's agreement to sell to material to be used exclusively in the defendant's own trade and for roofs and sidewalks. Defendant, by its counterclaim, avers failure by plaintiff to fill its large orders for material, which it claims plaintiff was bound by the contract to sell and deliver. It was open to plaintiff, under the separate general denial contained in its reply to the counterclaim, to contend, and establish by proof, if it was able to do so, that any part of the materials so ordered was not sought or intended by defendant to be used exclusively in its own trade, and for purposes of roofs and sidewalks, but for other purposes for which plaintiff was not bound to sell or deliver any materials. It is needless, in this connection, to consider the various meanings which may be ascribed to the word "trade." The

correct meaning in any particular case is arrived at by considering the word in the light of the subject-matter, and of all the provisions and the other language of the instrument in which it is found. In this contract the word is qualified and limited by other words in the same clause. The plaintiff only agreed to furnish the materials for use in the exclusive trade of the defendant, and it was also limited to be used only for roofing and sidewalks. It is safe to say that, as used by the parties in that instrument, it was not intended to grant to the defendant the right to go to all like corporations over the country, and by subcontracts for supplying each of them with materials bind the plaintiff to supply them all, through defendant, under this contract. It was competent, therefore, for the plaintiff to show, if it could, that materials ordered by the defendant, which were not shipped, and in respect of which the defendant claimed damages, were not ordered in good faith for defendant's exclusive use, but to fill the defendant's contracts to supply other corporations with large quantities of the same materials. Defendant's contract with the National Roofing Company had a tendency to support such contention, and was competent. If defendant, when it sent its large order of January 10, 1900, intended that the material so ordered, or any considerable part of it, should be applied, not to the exclusive use of defendant in its trade, but to fill the contract it had but a few days previously made with the National Roofing Company, or to fill any similar contract, such order was wrongful, and a fraud on plaintiff. And defendant could be entitled to no damages for the failure to deliver such material, whether the plaintiff then knew or did not know of the fraud intended. *Cooperage Co. v. Scofield* (C. C. A.) 115 Fed. 119, 121.

It cannot be said that there was no evidence to submit to the jury on which they might find that part of the refined Trinidad asphalt ordered by defendant of plaintiff, and for the nondelivery of which defendant claimed damages, was, when so ordered, intended for the National Roofing Company. Defendant's contract with that company was made December 30, 1899. By it the defendant agreed to sell and deliver to the National Roofing Company 500 tons of refined Trinidad asphalt yearly, shipments to be made from time to time in car-load or boat-load lots, as the roofing company might desire, at \$23.30 per ton, free on board cars or boat at Jones Point, N. Y. This was at plaintiff's plant, and the manner of delivery the same as plaintiff had agreed in respect to deliveries to defendant. Eleven days later defendant placed its order with plaintiff for 1,000 tons of refined Trinidad asphalt, to be sent on later shipping directions. Defendant's testimony shows that it always claimed that plaintiff should consign material it should order to whatever place it might direct. But little remained to render the circumstantial evidence very strong—almost conclusive—that this order was in part to supply the National Roofing Company, and that little was amply furnished by the defendant's evidence that at once, on plaintiff's refusal to further deliver to it refined Trinidad asphalt, and thereafter, it was unable to procure any of that material. Where, then, did the defendant purpose to procure the refined Trinidad asphalt which it had just con-

tracted to deliver to the National Roofing Company, as it might order it, in car-load or boat-load lots, shipped at Jones Point, N. Y.? What has just been stated applies to some of the exceptions taken to the charge of the court. We have examined all those exceptions with care, and find no error in the charge, which is a very full and fair presentation of the case, and covered the request which was refused so far as that was proper.

The verdict was in proper form, and disposed of all the issues, and the judgment is affirmed.

In re PENNEWELL.

(Circuit Court of Appeals, Sixth Circuit. December 2, 1902.)

No. 1,038.

1. **BANKRUPTCY—PROVABLE DEBTS—DAMAGES FOR BREACH OF COVENANT IN LEASE.**

A lessee cannot prove a claim for damages for breach of a covenant for quiet enjoyment in a lease against the estate of his lessor in bankruptcy because of his eviction after the filing of the petition in bankruptcy.

2. **LEASE—CONSTRUCTION—COVENANT AGAINST SUBLETTING.**

A stipulation in a lease against subletting, in the absence of some provision requiring it, will not be construed as a condition, but as a covenant, the breach of which will not work a forfeiture of the lease, nor authorize a re-entry by the lessor; hence such a stipulation does not render invalid a sublease made in violation thereof, nor give the sublessee a claim against his lessor for damages for false representation in stating that he had lawful right to make the lease.

3. **BANKRUPTCY—PROVABLE DEBTS—EFFECT OF ADJUDICATION ON SUBLEASE.**

The adjudication in bankruptcy of a lessee does not operate in itself to terminate his lease and end his estate, so as to give a sublessee a claim for damages which can be proved as a debt against his estate.

4. **FRAUDULENT REPRESENTATIONS—RIGHT OF ACTION FOR DAMAGES—MICHIGAN STATUTE.**

Comp. Laws Mich. § 10,421, which provides a remedy by an action of assumpsit to recover damages for an injury resulting from false representations, and attaches to the liability by implication a promise to pay such damages, merely gives a new remedy, and does not create any new right, or give a cause of action for a false representation before damages have resulted.

Petition for Revision of Proceedings of the District Court of the United States for the Eastern District of Michigan, in Bankruptcy.

Adolph Sloman, for petitioner.

Joseph H. Clark, for respondents.

Before LURTON, DAY, and SEVERENS, Circuit Judges.

SEVERENS, Circuit Judge. On January 29, 1901, the creditors of Charles F. Pennewell, the bankrupt, filed a petition in the district court for the Eastern district of Michigan, praying that he might be adjudged a bankrupt. Later in the same day he filed his voluntary petition in that court for the same purpose. Thereupon he was

adjudicated a bankrupt, and the matter was referred to a referee. The order of adjudication is not shown by the record, and it does not expressly appear upon which petition the order was made, but, as the petition of the creditors was first filed, and was pending, the fair inference is that it was upon that petition, the bankrupt's petition being treated as a consent thereto. At all events, this being a reasonable presumption, if the fact was otherwise it was incumbent on the petitioners to clearly show it in case they claimed any advantage from the suggestion that the order was based on Pennewell's voluntary petition. However, we do not think this material in the view which we take of the case. In the course of the proceedings Rosenwieg & Co. presented to the referee a petition founded on section 63, setting forth, in substance, that on August 15, 1899, they leased from the bankrupt the second floor of a certain department store in Detroit at a stipulated rent for the purpose of carrying on in the name of the lessor the business of the shoe department, with some collateral stipulations for privileges in the conduct of their business therein. By its terms this lease was to terminate May 1, 1901. The lessees were already in possession, and continued to occupy the premises under the lease for the purposes of their business until some time after the adjudication of bankruptcy, when they were dispossessed by the trustee. The lease contained a covenant for quiet enjoyment of the premises, and the petition averred that at the time of making it Pennewell expressly represented to the petitioners that he had good right and lawful authority to grant the lease of the premises, and that they relied upon this representation in becoming a party to it. On October 13, 1900, another lease was given and taken by the same parties of the same premises containing a like covenant and stipulations, and upon the same representation of the lessor, to run from May 1, 1901, to May 1, 1903. Relying upon these leases, the petitioners allege that they had built up a large and lucrative business, and acquired the good will of the public, and they stated that the leases were very valuable to them. But Pennewell himself was only a lessee of the building of which these premises were a part, under a lease from one Hunter, which expired May 1, 1903, the date of the expiration of Pennewell's second lease to the petitioners. The petition further stated that the lease from Hunter to Pennewell contained a stipulation by the lessee that the premises should not be sublet by him without the written consent of Hunter, of which the petitioners were not aware when they took their lease from Pennewell. Thereupon the petition proceeds to state that, subsequent to the time when Pennewell was adjudicated a bankrupt, Hunter, having learned of Pennewell's subletting of this part of the building, forfeited the lease to Pennewell, and claimed the right to re-enter the leased premises. Upon this state of facts the petitioners claimed that they were entitled to prove damages resulting to them from the alleged breach of Pennewell's covenant for quiet enjoyment and from the falsity of his express representation that he had lawful right to lease the premises to them, as above mentioned, and they prayed for an order directing the manner in which their claims and damages "could be liquidated and proved and allowed against said

estate." The trustee demurred to this petition upon the ground (in substance) that the petition did not state or show a debt or claim provable under the bankrupt act. Upon the hearing the referee sustained the demurrer, and dismissed the petition. On review the district judge confirmed the decision of the referee, and upon a petition for review by this court we are now to determine the correctness of the order of the district court.

1. Was the claim made one provable upon the ground that there had been a breach of the covenant for quiet enjoyment contained in the current lease from Pennewell to the petitioners? Under the express provision of section 63 of the bankrupt act [U. S. Comp. St. p. 3447], debts, to be provable, must be such as "are a fixed liability absolutely owing at the time of the filing of the petition." From the preceding statement it appears that the petitioners had been, from the date of their first lease, and were at the date of the filing of the petition for the order adjudging Pennewell bankrupt, and indeed until some time after, in the occupation of the leased premises, and it is not alleged that they had been in any manner disturbed in their quiet enjoyment of them. There had, therefore, been no breach of the covenant, and consequently no claim for damages had accrued. Such a covenant has reference to the future, and is quite distinct from such covenants as relate to existing facts which are broken as soon as made if contrary to the fact. Even if it be assumed that Pennewell's lessor had the right to elect to declare his lease to Pennewell forfeited, he had not done so at the time when the petition for an adjudication of bankruptcy was filed. Whether Hunter had such right we shall consider further on.

2. Was there a claim provable, which could be rested upon the ground of the false representation of Pennewell to his lessees that he had lawful right to make the lease or leases to them? It is true he had made a stipulation in his lease from Hunter that he would not sublet the premises. It was not stipulated, so far as appears, that his violation of this undertaking should forfeit the lease, or give the lessor the right to re-enter, and, as things not stated must be regarded as not existing, we must conclude that there was no provision in the lease that it might be forfeited by subletting the premises. The preponderance of authority is to the effect that such a stipulation by the lessee, in the absence of anything else in the lease leading to a different conclusion, does not forfeit the lease, or give the lessor the right of re-entry. The court leans against forfeitures, and when, as here, the other obligations of the lessee continue, and no special reason is shown for thinking that it was intended that the breach of the stipulation should furnish a reason for breaking up the entire contract, it would seem that the court should not adopt a construction which would impose a penalty, instead of giving a remedy for damages. The authorities, English and American, cited in 18 Am. & Eng. Enc. Law, 369, fully sustain the statement there made that:

"The common-law rule is well settled that a breach by the lessee of his covenants or agreements in the lease does not work a forfeiture of the term in the absence of an express stipulation in the lease or the reservation of a

power of re-entry in case of such breach. The general remedy of the lessor in such a case is merely by action for the recovery of damages. This rule applies in regard to implied covenants, express covenants to pay rent, covenants to pay taxes, covenants not to assign or sublet."

Among those authorities is *Hague v. Ahrens*, 53 Fed. 58, 3 U. S. App. 231, 3 C. C. A. 426, where, in dealing with a covenant of this kind, it was held that:

"A clause in a lease will not be treated as a condition if it can be construed to be a covenant without doing violence to its terms; and, if the purpose to create a condition or conditional limitation is not expressed in clear, unequivocal language, the clause will be treated as a covenant simply."

And such, we think, is the law of Michigan. *Langley v. Ross*, 55 Mich. 163, 20 N. W. 886; *Pickard v. Kleis*, 56 Mich. 604, 23 N. W. 329; *Hilsendegen v. Scheich*, 55 Mich. 468, 21 N. W. 894; *Hanaw v. Bailey*, 83 Mich. 24, 46 N. W. 1039, 9 L. R. A. 801. In *Hilsendegen v. Scheich*, Judge Champlin, delivering the opinion, said:

"And in a lease of this kind no precise form of words is necessary to make a condition, but the intention to do so must be evidenced by such language, taken in connection with the surrounding circumstances, as shows that the parties intended that it should have that effect; otherwise it will be held to be a covenant."

And in *Hanaw v. Bailey*, Judge Morse, in concluding his opinion, said:

"There was in this instrument no right of re-entry reserved upon failure to perform the covenants or conditions of the agreement; nor any stipulation therein that a failure to perform should operate as a forfeiture or termination of the lease,"—citing the earlier Michigan cases.

And in 1 Washb. Real Prop. *320 (3d Ed.), after a discussion of the effect of such covenants by the lessee, it is said:

"And it may be stated as a general proposition that courts always construe similar clauses as covenants only, rather than conditions or conditional limitations."

A case much in point is *Shaw v. Coffin*, 14 C. B. (N. S.) 372. The case of *Randall v. Chubb*, 46 Mich. 311, 9 N. W. 429, 41 Am. Rep. 165, is not in conflict with this doctrine, for in that case there were certain personal duties to be performed by the lessee, which were of the very substance of the lease, and the presence of such agreements in the lease was the ground on which the decision of the case turned. If the law be as above stated, this stipulation of the lessee did not affect the title under the lease, but was a personal agreement, merely, between Pennewell and Hunter, the breach of which would give a cause of action if damages ensued. It would follow, therefore, that, although Pennewell's subletting was a breach of his covenant with Hunter, such covenant and its breach did not affect the subleases to the petitioners. Moreover, the representation Pennewell is alleged to have made, namely, that he had lawful right to make the lease, amounted to no more than is implied in every such case when the lease is in the common form, and no damages could flow from it so long as the grantee remained in the undisturbed possession and enjoyment of the premises.

It is urged further that the adjudication of bankruptcy consented to by Pennewell ipso facto terminated his lease from Hunter, and put an end to his estate, whereby the leases to the petitioners were defeated, and that, in consequence, they had a claim for damages against the bankrupt's assets. We do not agree to these premises. It might be that the lease from Hunter was a valuable asset of the bankrupt, and, if so, the trustee might regard it as for the interest of the creditors to hold on to it, and convert the leasehold estate into distributable assets. And in the present case the petitioners alleged that the trustee had taken possession of the whole of the premises, and had sold the leasehold interest of Pennewell "subject to the rights of said Hunter" and of the petitioners, as the same should be determined. It may be true that, if the trustee had elected not to adopt the lease and realize its value to the estate, the lease would have come to an end. But we need not pursue that inquiry.

Reference is made to a statute of Michigan which is as follows (Comp. Laws, § 10,421):

"That in all cases where, by the fraudulent representation or conduct of any person, an injury has been or shall be produced, either to the person, property or rights of another, for which an action or the case for fraud or deceit may by law be brought, an action of assumpsit may be brought to recover damages for such injury, and in all such cases a promise shall be implied by law to pay all just damages arising from such fraud or deceit, and may be so declared upon." 3 Comp. Laws, p. 3150.

This statute provides for a remedy by an action of assumpsit for injurious false representations, instead of the action of trespass upon the case, which was the old form of remedy, and attaches to the liability a promise to pay the damages. Since every man is bound to pay such damages, and his obligation is not increased by making a promise, it seems probable that this language was employed to make the ground of the action conform to the theory on which the new remedy had always been regarded as having its foundation. But, however that may be, it is clear that it was not intended to create any new right, or to give a cause of action, before any damages had resulted. If none ever result, there is no injury, and, of course, no action in any form could be maintained. None had resulted when the petition for adjudicating Pennewell a bankrupt was filed, and none might ever arise. And so there was no debt absolutely owing to the petitioners at that time. We need say no more in this connection than to refer to what we have already said in regard to the effect upon the rights of the petitioners of Pennewell's covenant not to sublet in his lease from Hunter.

Perceiving no error in the proceedings of the district court, we must affirm the order complained of.

YORK MFG. CO. v. ROTHWELL,

(Circuit Court of Appeals, Sixth Circuit. December 2, 1902.)

No. 1,069.

1. COUNTERCLAIM—ACTION AGAINST JOINT MAKER OF NOTE—RIGHT TO MAKE COMMON DEFENSE.

One of two joint makers of a note, when sued alone thereon, may plead as a counterclaim a breach of warranty in respect to machinery for the purchase price of which the note was given, and which was sold by the plaintiff to the makers of the note jointly.

In Error to the Circuit Court of the United States for the Northern District of Ohio.

This action was brought to recover the amount alleged to be due on two promissory notes delivered to the plaintiff by Rothwell, the defendant in error, and John Lovett, as joint makers,—one for the sum of \$2,000, and dated February 23, 1899, and one for \$1,000, dated March 27, 1899, and due respectively in 90 days from date. Service of process was made upon Rothwell, but Lovett was not served. Rothwell appeared and answered, admitting the making and delivery of the notes, and filed a counterclaim (called in the record a "cross-petition") in which he alleged that the notes were renewals of others which had been given for part of the purchase price of an ice-making plant, which the plaintiff constructed and supplied for Rothwell & Lovett under a contract wherein the vendor guaranteed that the machinery should have a "capacity for producing not less than twenty tons of good, clear, marketable ice every twenty-four hours; that the same would not require more than sixty gallons of water per minute, at a maximum temperature of 60 degrees Fahr.; and that said machinery would produce five and one-half tons of ice for each ton of good steam coal, 85 to 90 per cent. combustible,"—whereas, it was averred, "the said ice-making machinery so sold was not as guaranteed and represented, but was defective, in this: that said ice machinery would not and did not produce good, clear, marketable ice, because of defects in said machinery, which permitted oil and other foreign substances to accumulate in the condensed water from which ice was frozen; that the condensers, jackets, and distilling apparatus ordinarily required more than sixty gallons of water per minute at a maximum temperature of 60 degrees Fahr., and the ice machine would not produce five and one-half tons of ice for each ton of good steam coal consumed, of from 85 to 90 per cent. combustible; that the failure of said machinery to produce the quantity and quality of ice with the amount of water and coal as aforesaid was due to no fault of defendant, but was the fault of plaintiff in the erection and construction of same; that said Rothwell & Lovett, at divers times since the giving of said notes, notified plaintiff in error that said machinery was not producing the quantity and quality of ice as provided by said contract; and that, by reason of the breach of the guaranty, he [Rothwell] was damaged in the sum of \$5,000." To this cross-petition the plaintiff filed a reply, which amounted, in substance, to a denial of the matters therein alleged. Upon the trial, which was by a jury, the plaintiff produced the notes, proved the amount due thereon, and rested. The defendant went into evidence in support of his cross-petition against the objection of the plaintiff that the said cross-petition did not allege any valid defense, and did not state any facts which were available to the defendant as grounds for a counterclaim. The court held otherwise, and the plaintiff took seasonable exceptions as the trial progressed. At the close of the evidence these objections were renewed, and the plaintiff's counsel requested an instruction to the jury that the defendant was not entitled to maintain his cross-petition. The request was refused, and the plaintiff excepted. The jury returned a verdict for the plaintiff for the sum due on the notes in the sum of \$3,428.65, and for the defendant on his counterclaim for the sum of \$1,500. The court rendered a judgment in favor

of the plaintiff for the difference; that being, in amount, \$1,928.65. The plaintiff, complaining that his recovery was reduced by the counterclaim, sued out this writ of error.

Louis J. Dolle, for plaintiff in error.

Before LURTON, DAY, and SEVERENS, Circuit Judges.

SEVERENS, Circuit Judge, having made the foregoing statement of the case, delivered the opinion of the court.

There are a great number of assignments of error, but counsel for the plaintiff have simplified the points for review by substantially limiting the discussion to the first three, which are as follows:

"(1) The court erred in overruling the plaintiff's objection to admission of any evidence in support of the defendant's answer and counterclaim. (2) In overruling the plaintiff's motion, made at the close of the evidence offered in chief by the defendant, to direct the jury to return a verdict in favor of the plaintiff, and in overruling the said motion when the same was again renewed at the close of the evidence offered by the plaintiff, and at the close of that offered by the defendant in rebuttal. (3) In refusing to charge the jury as requested by the plaintiff in his request No. 1, which was as follows: '(1) Under the evidence in this case, the defendant is not entitled to a recovery of the claim set forth in his cross-petition, and your verdict should be for the plaintiff for the amount claimed in the amended petition.'"

These propositions are, however, resolvable into two: First, whether the counterclaim was maintainable at all; and, second, whether the evidence given in support of it was sufficient to justify the verdict which established it.

Before proceeding to the discussion of these questions, it should be noted that although the cross-petition speaks of the purchasers of the plant as if they were joint purchasers, simply, the contract offered in evidence shows that it was made by them as partners under the firm name of Rothwell & Lovett. But no question of variance was raised at any time in the court below, and, under the practice of the courts of Ohio, the variance would in such case be disregarded, and the verdict and judgment would be such as the evidence requires.

First, upon the question whether the counterclaim is maintainable upon the case exhibited by the pleadings, it should be observed that we do not have to deal with the question whether one of several joint obligors may, in a suit prosecuted against him alone, recoup damages growing out of some disconnected and independent transaction between the plaintiff and the joint obligors. In the present case the subject-matter of the counterclaim inhered in the original transaction, and touched the consideration of the notes. The action was brought against both the makers, and if service had been made upon both, and the other maker had appeared, no question could have arisen of the right of recoupment. Can the defendant be put in a worse position by the failure of the plaintiff to get service upon the other obligor? The cause of action is still the joint obligation, and is not converted into a several obligation until the judgment is reached. The plaintiff is permitted to pursue to judgment one obligor, when he cannot get service upon the others, because otherwise there might be a total failure of justice. But when the obligor against

whom the recovery is sought has an interest in the subject-matter out of which the cause of action is evolved, it would be an injustice to him to deny him its protection, and turn him around to an independent suit with his co-obligor joined as plaintiff. When the counterclaim, in such a case as this, is founded upon the very consideration of the cause of action, it would seem that the defendant has an absolute right to have his liability settled upon its essential grounds. As said by Mr. Justice Field in *Railroad Co. v. Smith*, 21 Wall. 255, 22 L. Ed. 513:

"The law does not require a party to pay for defective and imperfect work the price stipulated for a perfect structure, and, when that price is demanded, will allow him to deduct the difference between that price and the value of the inferior work, and also the amount of any direct damages flowing from existing defects, not exceeding the demand of the plaintiffs. This is a rule of strict justice, and the deduction is allowed in a suit upon the contract to prevent circuity of action."

In delivering the opinion in *Winder v. Caldwell*, 14 How. 434, 14 L. Ed. 487, Mr. Justice Grier said of a claim to recoup in a suit on a building contract:

"Although it is true, as a general rule, that unliquidated damages cannot be the subject of set-off, yet it is well settled that a total or partial failure of consideration, acts of nonfeasance or misfeasance, immediately connected with the cause of action, or any equitable defense arising out of the same transaction, may be given in evidence in mitigation of damages, or recouped, not strictly by way of defalcation or set-off, but for the purpose of defeating the plaintiff's action in whole or in part, and to avoid circuity of action."

The plaintiff has no right to anything beyond this, and cannot be injured by being restricted to such limits. He cannot, after the counterclaim has been thus used, be sued either by the absent party alone, or by him and the original defendant jointly; for in the first instance his action would be subject to abatement for nonjoinder, and in the second the original defendant would be estopped. It may be said that the absent party would thus have his rights precluded without a hearing. But if his co-obligor is left exposed to suit alone upon the joint obligation, the absent party cannot justly complain if his associate makes use of the common defense.

The authorities are quite numerous to the effect that, in circumstances such as are shown in the case before us, one of the joint obligors, when being pursued upon the joint obligation, is entitled to make a common defense, especially when that defense is founded upon matters which are vitally connected with the cause of action. In *Stackwood v. Dunn*, 3 Q. B. 822, the defendant, who was sued for work and labor, pleaded to the merits that the promises declared upon were made by himself jointly with another, and that the plaintiff was indebted to him and the others jointly, and demanded a set-off. This plea was demurred to upon the ground that the debts were not mutual. Upon the argument, this point being pressed, Coleridge, J., inquired:

"Suppose the third party to be out of the jurisdiction of the court; is the defendant to lose his set-off?" And he further said: "Your demurrer admits that you are suing on a debt due from the two jointly;" and, again, "The debts on both sides are in fact in the same right."

To the suggestion of counsel that the debt set up by the defendant was not in the same right as that claimed by the plaintiff, Wightman, J., said:

"That is the fallacy of your argument. You sue a single party on a joint debt, as you can do, if the defendant does not choose to plead in abatement; but still it is a joint debt on which you are suing."

All the judges agreeing, the judgment was for the defendant. This was a case of set-off, where the rule in respect of mutuality is even more strict than in the case of recoupment; the latter partaking more of the character of an equitable defense.

In *McHardy v. Wadsworth*, 8 Mich. 349, the action was upon a promissory note, against the two makers. They made defense by claiming that the note sued on was given for the price of cattle sold by the plaintiff to one of them with a warranty which proved to be false, and they claimed that the damages might be recouped against the sum due on the note. The trial judge held that the two defendants could not make the defense of recoupment upon a sale made to one only, for want of mutuality. This was held to be error. Christyancy, J., in delivering the opinion of the court, said:

"If recoupment were allowed on the same principle of a set-off, merely, this objection would be insurmountable. A set-off is in the nature of a cross-action to the full extent. It does not deny the validity of any part of the plaintiff's claim or cause of action, but sets up a separate and independent claim against the plaintiff, and the defendant is entitled to judgment upon any surplus of his claims beyond those of the plaintiff. A defense by way of recoupment denies the validity of the plaintiff's cause of action to so large an amount as he claims. It is not an independent cross-claim, like a separate and distinct debt or item of account due from the plaintiff, but is confined to matters arising out of or connected with the contract or transaction which forms the basis of the plaintiff's action. It goes only in abatement or reduction of the plaintiff's claim, and can be used as a substitute for a cross-action only to the extent of the plaintiff's demand."

To the same effect are *Sillivant v. Reardon*, 5 Ark. 140; *Mott v. Mott*, 5 Vt. 111; *McKinnon v. Palen*, 62 Minn. 188, 64 N. W. 387; *McMasters v. Burnett*, 92 Ky. 358, 17 S. W. 1021; *Elliott v. Espenhain*, 54 Wis. 231, 11 N. W. 513. And such is the law in Ohio. *Wagner v. Stocking*, 22 Ohio St. 297. There is nothing in the cases (*Transportation Co. v. Earhart* [C. C.] 96 Fed. 925; *Joice v. Cockrill*, 92 Fed. 838, 35 C. C. A. 38; *Gray v. Rollo*, 18 Wall. 629, 21 L. Ed. 927; *Bank v. Hunt*, 72 Vt. 357, 47 Atl. 1078; *Adams v. Bliss*, 16 Vt. 42; *Johnson v. Kelly*, 67 Vt. 386, 31 Atl. 849; *Sullivan v. Nicoulin*, 113 Iowa, 76, 84 N. W. 978; *Miller v. Crigler*, 83 Mo. App. 395; *Morris v. Dock Co.*, 91 Ill. App. 437; *Wolfe v. Jasspon*, 126 Mich. 11, 85 N. W. 260) cited by the plaintiff which militates against this doctrine in its application to the facts and circumstances of the present case.

The case of *Joice v. Cockrill* was decided by this court. So far as it is at all pertinent to the question here involved, the case was this: The action was upon a promissory note of two makers, one of whom was surety for the other. The note was given for part of the purchase price of some property sold to the principal maker by a receiver under the order of a court. Part of the property sold

consisted of some promissory notes then in the hands of a bank. The note in suit was assigned by the receiver to the bank, and, the bank having failed, its receiver brought suit to recover the sum due upon it. One of the defenses made by the surety was that the promissory notes above mentioned (those sold by the receiver to the principal maker of the note in suit) had not been delivered to the purchaser, and were wrongfully withheld from him by the bank, whereby there had been a partial failure of the consideration for the note in suit. It was not denied by this court that the general rule would permit the surety to make the defense of his principal and co-obligor. Indeed, it was said by Judge Lurton, delivering the opinion:

“Undoubtedly, a surety may, when the contract has not been assigned to a purchaser for value without notice, when called upon to perform, show either a total or partial failure of the consideration of his principal’s contract. But such a defense, when made by the surety, must be one which would be available to the principal, if sued.”

Certain facts in the case were then stated which showed that the principal himself could not maintain the defense. Moreover, it appeared that there was outstanding another purchase-money note, of identically the same character, in which another party was the surety, and who had an equal right to the benefit of this defense, if it was available to a surety, and he was not before the court. It was upon this last ground that the principle of the decision in *Transportation Co. v. Earhart* (C. C.) 96 Fed. 925, also above cited, rests.

With regard to the question whether the evidence was sufficient to justify the verdict, it is to be observed that it is one of fact. We have examined the proofs which were given to the jury, and, without going into detail, which would serve no general purpose, we are satisfied that the court did not err in submitting the question to them. There are some minor points of trifling consequence, but we perceive no error in respect to them.

The judgment should be affirmed.

BROWN v. NORTHWESTERN MUT. LIFE INS. CO. (two cases).

(Circuit Court of Appeals, Eighth Circuit. December 3, 1902.)

Nos. 1,424, 1,425.

1. APPEAL BOND—SUPERSEDING SALE OF REAL ESTATE—RENTS AND PROFITS RECOVERABLE AS DAMAGES.

The obligee in a bond which supersedes an order confirming a sale of real estate, and directs the immediate execution of a deed and delivery of possession thereof to the purchaser, is entitled, after that order has been affirmed on appeal, to recover as damages for the breach of the obligation of the bond the value of the use and possession; that is to say, in this case, the rents and profits of the real estate during the time the purchaser is kept out of the possession and use of the real estate by the supersedeas bond and the appeal in which it was allowed.

2. SAME—ANY JUDGE AUTHORIZED TO SIGN CITATION MAY APPROVE.

The appeal bond taken under Rev. St. §§ 1000, 1012 [U. S. Comp. St. 1901, pp. 712, 716], may be approved by any judge or justice who is

† 2. See Appeal and Error, vol. 2, Cent. Dig. § 2061.

authorized to sign the citation and to allow the writ of error or appeal. It is not essential to its validity that it be approved by the justice or judge who allows the writ of error or appeal or signs the citation.

(Syllabus by the Court.)

In Error to the Circuit Court of the United States for the District of Nebraska.

Appeal from the Circuit Court of the United States for the District of Nebraska.

John N. Baldwin, for plaintiffs in error and appellants.

Howard Kennedy, Jr., for defendant in error and appellee.

Before CALDWELL and SANBORN, Circuit Judges, and ADAMS, District Judge.

SANBORN, Circuit Judge. These cases involve a summary judgment rendered in a foreclosure suit against the sureties on a supersedeas bond given on an appeal from an order confirming a sale under a decree of foreclosure. This judgment is assailed both by writ of error and by appeal. It is a judgment in the foreclosure suit, and can be challenged by appeal only. The writ of error is accordingly dismissed, and the case presented by the appeal is considered.

The serious question in the case was certified to the supreme court, and has been answered in the affirmative. It was:

"Is the obligee in a bond, which supersedes an order confirming a sale of real estate and directs the immediate execution of a deed and delivery of possession thereof to the purchaser, entitled, after that order has been affirmed on the appeal, to recover as damages for the breach of the obligation of the bond the value of the use and possession; that is to say, in this case, the rents and profits of the real estate during the time the purchaser is kept out of the possession and use of the real estate by the supersedeas bond and the appeal in which it was allowed?" *Woodworth v. Insurance Co.*, 185 U. S. 354, 22 Sup. Ct. 676, 46 L. Ed. 945.

The record presents but one other matter: It is whether or not the bond is void because the judge who allowed the appeal and signed the citation did not approve the bond. It was subsequently approved by Hon. Amos M. Thayer, United States circuit judge for this circuit, who had authority both to allow the appeal and to approve the bond. Section 1000 of the Revised Statutes [U. S. Comp. St. 1901, p. 712], provides that:

"Every justice or judge signing a citation on any writ of error [and appeals are governed by the same rule; Rev. St. § 1012, (U. S. Comp. St. 1901, p. 716)] shall * * * take good and sufficient security that the plaintiff in error or the appellant shall prosecute his writ or appeal to effect, and if he fail to make his plea good, shall answer all damages and costs where the writ is a supersedeas and stays execution, or all costs only when it is not a supersedeas as aforesaid."

The contention of the appellants' counsel is that this section of the statute must be literally construed, and that the bond is void because it was not approved by the justice or judge who signed the citation. But this interpretation of the statute is too narrow and technical. It ought to have, and has constantly received, a broader and more liberal construction,—the construction that the bond may be approved by any judge or justice who was vested with the power to sign the cita-

tion and to allow the writ of error or appeal in the first instance. *Catlett v. Brodie*, 9 Wheat. 553, 555, 6 L. Ed. 158; *O'Reilly v. Edrington*, 96 U. S. 724, 24 L. Ed. 659; *Hudson v. Parker*, 156 U. S. 277, 15 Sup. Ct. 450, 39 L. Ed. 424. The judge who finally approved the bond had authority to do so, although he did not sign the citation, and the bond constituted a valid obligation of the sureties.

The judgment below must be affirmed, and it is so ordered.

FLORENCE OIL & REFINING CO. v. FARRAR et al.

(Circuit Court of Appeals, Eighth Circuit. November 18, 1902.)

No. 1,767.

1. DAMAGES—BREACH OF CONTRACT TO FURNISH MACHINERY.

The measure of damages for the breach of a contract for furnishing machinery, boilers, or other personal property, which is accepted and put in use by the vendee in excusable ignorance that it fails to comply with the agreement, is the difference between its value as it would have been if it had complied with the contract and its value in its defective condition.

2. PRACTICE—VERDICT AND JUDGMENT LESS FAVORABLE THAN OFFER ERRONEOUS.

Under section 281 of Mills' Annotated Code of Colorado, a judgment upon a verdict less favorable than an offer of judgment tendered by the defendant and rejected is erroneous.

(Syllabus by the Court.)

In Error to the Circuit Court of the United States for the District of Colorado.

Thomas M. Patterson, Edmund F. Richardson, and Horace N. Hawkins, for plaintiff in error.

Henry T. Rogers, Lucius M. Cuthbert, Daniel B. Ellis, and Pierpont Fuller, for defendants in error.

Before CALDWELL, SANBORN, and THAYER, Circuit Judges.

SANBORN, Circuit Judge. This was an action to recover the purchase price of certain boilers, engines, and personal property. The defense was that the vendors agreed that the boilers should be of the first and best quality of workmanship and material; that the defendant below, the Florence Oil & Refining Company, did not know and could not have ascertained that the boilers did not comply with the contract when it accepted them, but that, while they would have been reasonably worth their contract price if they had been of the promised character and quality, they were so inferior in material and workmanship that they were worth much less. The defendant further answered that on March 21, 1899, it offered to allow the plaintiffs to take judgment against it for the costs of the action and \$2,269.62, which was the entire amount then due on the causes of action set forth in the complaint, but that the plaintiffs refused to accept this offer. At the trial the defendant offered to prove by a competent witness the reasonable value of the boilers actually delivered by

the plaintiffs, and that each of them was worth from \$150 to \$175 less than their contract price. The court rejected this testimony, and the defendant excepted. This was a plain error. The measure of damages for the breach of a contract for furnishing machinery, boilers, or other personal property, which is accepted and put in use by the vendee in excusable ignorance that it fails to comply with the agreement, is the difference between its value as it would have been if it had complied with the contract and its value in its defective condition. 2 Suth. Dam. § 699; Mack v. Sloteman (C. C.) 21 Fed. 109, 117; White v. McLaren, 151 Mass. 553, 557, 24 N. E. 911; Swain v. Schieffelin, 134 N. Y. 471, 473, 31 N. E. 1025, 18 L. R. A. 385. The case of Philip Schneider Brewing Co. v. American Ice Mach. Co., 77 Fed. 138, 23 C. C. A. 89, cited by counsel for the defendants in error, does not state the rule of law applicable to the measure of damages in this or any other case in which general damages are sought for the breach of a contract to furnish machinery or personal property. In that case an action was brought for the recovery of the purchase price of a complicated machine. The defendant pleaded that certain specific parts of this machine were defective, and sought to reduce the plaintiff's recovery on account of the specific defects it set forth. The court held the defendant to its pleading, and declared that, inasmuch as it had specified the particular parts of the complicated machine which were defective, its proof must be limited to the damages it sustained from the specified defects it pleaded. No specifications were made in the action at bar, and the damages which the defendant sought to offset against the price of the engines and personal property in this action consisted of the difference between the boilers as they actually were, and as they would have been if the contract had been fulfilled.

The statute of Colorado provides that where the defendant offers to allow judgment to be taken against him for a certain sum, and the plaintiff rejects the offer, and fails to obtain a more favorable judgment, he shall not recover costs, but shall pay the costs of the defendant from the date of the offer. Mills' Ann. Code Colo. § 281. The defendant in this case offered to allow judgment against it for \$2,269.62 and costs on March 21, 1899, and this offer was rejected. On January 27, 1902, the plaintiffs recovered their verdict in this action for the sum of only \$2,754.19. The legal rate of interest in Colorado is 8 per cent. per annum. The verdict and judgment which the plaintiffs have recovered are less favorable than the offer which was made by the defendant, because the amount of that offer, with interest thereon at the legal rate from the time it was made to the date of the verdict, exceeds the amount of the verdict. The verdict was therefore wrong, and the judgment is vulnerable upon this ground. Counsel for the defendant below (the plaintiff in error here) pray that the plaintiffs may be required to remit the excess above the amount of the offer, \$2,269.62, or that the judgment be reversed. The errors to which reference has been made entitle them to this relief.

The judgment below is accordingly reversed, and the case is remanded to the circuit court, with instructions to render a judgment in favor of the plaintiffs for the sum of \$2,269.62 and the plaintiffs'

costs to March 21, 1899, less the costs of the defendant in that court from March 21, 1899, to the entry of the judgment, in case the plaintiffs, within 60 days after the receipt of the mandate herein, remit the difference between this amount and the amount of the verdict and judgment already rendered, and that in case they fail to remit this difference the court grant a new trial of the action.

ABNER DOBLE CO. v. UNITED STATES.

(Circuit Court of Appeals, Ninth Circuit. October 6, 1902.)

No. 692.

1. CUSTOMS DUTIES—LIQUIDATION—LIMITATION OF TIME.

The provision of section 21 of Act June 22, 1874 [U. S. Comp. St. 1901, p. 1986], limiting the time within which duties may be reliquidated to one year from the date of entry in the absence of fraud or protest by the owner or importer, does not operate to prevent the liquidation of duties on an article at any time after its entry in bond upon or after its withdrawal for consumption when there had been no previous liquidation.

2. SAME—ACTION TO RECOVER DUTIES—SUFFICIENCY OF COMPLAINT.

A complaint by the United States, alleging that defendant made withdrawal entry, and withdrew from a bonded warehouse for consumption imported goods which were dutiable, and upon subsequent liquidation of the duties thereon paid the greater portion of such duties without protest, states a cause of action for the recovery of the remainder, although it shows that defendant was not the importer, the presumption being from the facts alleged that it bore such relation to the goods as to be chargeable with the duties.

In Error to the District Court of the United States for the Northern District of California.

The United States, in an action against the plaintiff in error, the Abner Doble Company, a corporation, alleged, in substance: That on March 8, 1892, William Murray imported into the United States at San Francisco from Liverpool 2,779 bars and 2,051 bundles of Swedish charcoal iron, which was subject to the payment of a duty of \$2,341.50 under the tariff act of October 1, 1890. That on March 14, 1892, William Murray made warehouse entry of said merchandise, and on March 15, 1892, the merchandise was placed in a bonded warehouse, upon the execution and delivery of a warehouse bond therefor by William Murray as principal and R. B. Hul as surety. That said merchandise remained in the bonded warehouse for more than three years from the date of its original importation, and on March 8, 1895, became abandoned to the United States, and subject to sale as such. That on March 15, 1895, the plaintiff in error made final withdrawal entry for consumption of said merchandise, and withdrew the same from bond, and on April 24, 1895, duties thereon were finally ascertained and liquidated by the collector at the sum of \$2,341.50, pursuant to law and the regulations and practice of the treasury department. That no notice of objection or protest was given to said collector of such liquidation or ascertainment of duties. That there has been paid upon the withdrawal of such merchandise from bond the sum of \$2,291.32 on account of said duties, leaving a balance payable of \$50.18, for which judgment was demanded. The plaintiff in error demurred to the complaint upon the grounds that it failed to state facts sufficient to constitute a cause of action, that the cause of action is barred by the provisions of the act of congress of June 22, 1874, and that the complaint is ambiguous and uncertain. The demurrer was overruled, and, the plaintiff in error failing to answer, judgment was rendered as sued for. It is assigned as error that the court held the plaintiff in error liable for duties for merchandise imported by William

Murray; that the court ruled that the cause of action is not barred by the provisions of the act of congress of June 22, 1874; that the court ruled that the complaint is not uncertain, in that it fails to set forth why the duties on merchandise were not ascertained at the time when the plaintiff in error made final withdrawal, or to set forth the reason why the duties on the merchandise referred to were not ascertained at that time; and that the court erred in determining that the complaint states facts sufficient to constitute a cause of action.

Jesse W. Lilienthal and Frohman & Jacobs, for plaintiff in error.
Marshall B. Woodworth, for the United States.

Before GILBERT and ROSS, Circuit Judges, and HAWLEY, District Judge.

GILBERT, Circuit Judge, after stating the case as above, delivered the opinion of the court.

The plaintiff in error contends that the complaint does not state a cause of action against it, for the reason that it charges it with duties on goods not imported by it, or consigned to it, but imported by another; and it asserts that there is no statute which makes one who withdraws goods from a bonded warehouse chargeable with the duties thereon unless he was the importer or consignee; quoting 1 Supp. Rev. St. 744 [U. S. Comp. St. 1901, p. 1886]:

"That all merchandise imported into the United States shall, for the purpose of this act, be deemed and held to be the property of the person to whom the merchandise may be consigned; but the holder of any bill of lading consigned to order and endorsed by the consignor shall be deemed the consignee thereof; and in case of the abandonment of any merchandise to the underwriters, the latter may be recognized as the consignee."

The decisive facts alleged in the complaint upon which the plaintiff in error was held liable were that the plaintiff in error made withdrawal entry, and withdrew the goods for consumption, and that some six weeks later the duties were finally ascertained and liquidated by the collector at \$2,341.50, which sum the plaintiff in error paid except a balance of \$50.18, for which the action was brought. The law does not prescribe the time when the collector shall liquidate the duties. He may liquidate before or after a year after entry. The only limitation upon his action in that regard is that, after once liquidating, he may not, in the absence of fraud or protest by the owner, importer, agent, or consignee, reliquidate after a year from the date of entry. Section 21, Act June 22, 1874 [U. S. Comp. St. 1901, p. 1986]; U. S. v. De Rivera (C. C.) 73 Fed. 679; Gandolfi v. U. S., 20 C. C. A. 652, 74 Fed. 549. We agree with the district court that the question whether the government is estopped from maintaining the action by section 21 of the act of June 22, 1874 [U. S. Comp. St. 1901, p. 1986], is not presented by the facts alleged in the complaint, since there is no averment that the duties were liquidated prior to April 24, 1895. In the averment of the complaint that the plaintiff in error made withdrawal entry, and withdrew the goods for consumption, and paid all the duties except the small balance unpaid, there is implied that the plaintiff in error sustained such relation to the goods, whether as consignee or underwriter or otherwise, as to entitle it to make such withdrawal. Admitting, as it does by the demurrer,

that it made the entry and the withdrawal for consumption, and paid a sum on account of the duties so liquidated, it cannot say that the complaint is fatally defective for the reason that it fails to set forth what was the precise relation of the plaintiff in error to the goods. From the facts pleaded, the presumption arises that the plaintiff in error was chargeable with the duties. If facts existed which were sufficient to overcome that presumption, they constituted matter of defense to the complaint, available by answer. On the face of the complaint a cause of action is stated.

The judgment of the district court is affirmed.

ELIZABETH CITY COTTON MILLS v. LOEB.

(Circuit Court of Appeals, Third Circuit. December 16, 1902.)

No. 7.

1. CONTRACTS—RELATION OF PARTIES—BUYER AND SELLER—PRINCIPAL AND AGENT—EVIDENCE—ADMISSIBILITY.

Where, in an action for breach of an alleged contract of sale, defendant set up that no such contract was made, but that the negotiations related to his employment as agent, merely, and plaintiff, to sustain his case, introduced only a part of the correspondence between the parties, it was not error for the court to admit all the correspondence and the conversations of the parties relating to the transaction as an entirety, especially where the correspondence introduced by plaintiff was ambiguous.

In Error to the Circuit Court of the United States for the Eastern District of Pennsylvania.

C. Wilfred Conrad, for plaintiff in error.

W. Horace Hepburn, for defendant in error.

Before ACHESON, DALLAS, and GRAY, Circuit Judges.

DALLAS, Circuit Judge. This was an action by the plaintiff in error, as vendor, against the defendant in error, as vendee, to recover for the breach of an alleged contract of sale of yarn. The defense was that no such contract had been made; that the defendant's negotiations with the plaintiff were not for a purchase by the defendant himself, but related wholly to his employment, as agent of the plaintiff, to make sales to others for its account. The parties had had a correspondence, and also some oral communications, during a period extending from December, 1899, to June, 1900; and to maintain its allegation that the defendant had bought yarn from it, which he afterwards refused to accept, the plaintiff relied upon only a part of that correspondence, as follows:

"March 21st, 1900.

"Mr. Oscar D. Loeb, Philadelphia, Pa.—Dear Sir: We would like to have an offer from you for about 75,000 to 100,000 lbs. No. 30/2 ply yarn (warp), and about 20,000 lbs. 20/1, deliveries to begin in June at the rate of about 10,000 lbs. of 30/2 ply, and 4,000 lbs. of 20/1, weekly.

"Yours very truly,

Elizabeth City Cotton Mills,

"By J. J. Gregory, Sec."

"March 22nd, 1900.

"Messrs. Elizabeth City Cotton Mills, Elizabeth City, N. C.—Gentlemen: Your favor of the 21st inst. to hand, and in reply thereto would say that I can

sell 50,000 lb. of 30/2 warps, 10,000 lb. weekly, beginning in June, at 30c. per lb., and 20,000 lb. of 20/1 warps, 4,000 lb. weekly, beginning in June, at 21c. per lb., which I trust will meet with your approval. Could, no doubt, secure additional orders on these numbers for you later on. Thanking you for giving me the opportunity, and hoping to receive a favorable reply by return mail, I remain,

"Yours very respectfully,

Oscar D. Loeb.

"Dic. O. D. L.

"Hope we will trade this time, and, if so, for always."

(Telegram.)

"March 26, 1900.

"Oscar D. Loeb, 226 Chestnut Street, Philadelphia: Accept your offer fifty 50,000 thousand thirties and twenty 20,000 thousand twenties.

"Elizabeth City Cotton Mills."

"March 26, 1900.

"Mr. Oscar D. Loeb, Philadelphia, Pa.—Dear Sir: We have your favor of the 22nd, stating that you can sell 50,000 lbs. 30/2 ply at 30c., delivery 10,000 lbs. weekly, beginning in June, and 20,000 lbs. 20/1 at 21c., delivery 4,000 lbs. weekly, beginning in June, and we have wired you, 'Accept your offer 50,000 thirties and 20,000 twenties,' which we now confirm. We figure that we may be able to begin deliveries on 30/2 ply, possibly, about the middle of May at the rate of about 5,000 lbs. weekly, which will be about as well as we can do until July, when we could increase to about 15,000 lbs. weekly. We figure that we can begin on the twenties as desired, 4,000 lbs. weekly, from about the middle of June.

"Yours very truly,

Elizabeth City Cotton Mills," etc.

"Subject to accidents, strikes, or other delays beyond our control."

"Philadelphia, March 28, 1900.

"Messrs. Elizabeth City Cotton Mills, Elizabeth City, N. C.—Gentlemen: Your message of the 26th inst. to hand, as follows: 'Accept your offer fifty thousand thirties and twenty thousand twenties,' also your letter of same date confirming same, contents of which I note. As the delivery on these goods is quite some distance off yet, my customer prefers waiting to give me the descriptions until you are about ready to begin shipments, so as to avoid changes, if possible. From our conversation when I was at your place last, I presume that you will confine the handling of your entire production to me from the date deliveries begin on my orders, so long as everything is satisfactory. Would kindly ask you to reply to this by return mail, so that I may know how to act in selling your yarns, and that I may know that none of my competitors will be able to offer your yarns to the same people, thereby avoiding an unnecessary and unwholesome competition. Being assured of this by you, it will enable me to hold firm at full market value, and also bar the trade here informing me that they can buy the same yarns from my competitors for less money. Hoping to hear from you favorably, and that this order is the forerunner of many more, I remain,

"Yours very respectfully,

Oscar D. Loeb.

"Dic. O. D. L."

"April 3rd, 1900.

"Mr. Oscar D. Loeb, Philadelphia, Pa.—Dear Sir: Replying to your inquiry of March 28th, will say that we are not prepared to turn over our account in full to you. That will depend upon later developments, which we cannot foresee. We are giving you a trial, which, if it proves satisfactory, may lead to further business with you.

"Yours very truly,

Elizabeth City Cotton Mills," etc.

"April 9, 1900.

"Messrs. Elizabeth City Cotton Mills, Elizabeth City, N. C.—Gentlemen: Your favor of 3rd instant to hand, and contents noted. Replying to same, would say that it is not satisfactory, and, as you will not guaranty me your production, I withdraw my order as same was given you with the understanding based upon our recent conversation at your place, when you told

me that you would confine your production to one house only, and I cannot afford to handle it under any other conditions, and take the chances that I have taken in paying you the fullest prices for yarns on a declining market, with the possibility of receiving no more yarns from you, and, if so, only a part of same, and the balance of your production coming in competition with itself by its sale through my competitors. I am sorry that my first attempt in this matter should turn out this way, but I assure you that there was no other object in my going to all the trouble that I have gone to, except for the reasons above. Under your conditions, you place yourself in the same state as most other mills with whom I am doing business, and with whom I would not place orders for future delivery at these prices, and take such chances, unless with the object in view as above stated.

"Yours very respectfully,
"Dic. O. D. L."

Oscar D. Loeb.

"June 4th, 1900.

"Oscar D. Loeb, Philadelphia, Pa.—Dear Sir: In conformity with your letter of March 26th, we beg to advise you that we are now ready to take up the orders for 50,000 lbs. No. 30/2 ply and 20,000 lbs. No. 20/1. Please forward descriptions and shipping instructions promptly.

"Yours very truly,

Elizabeth City Cotton Mills," etc.

"June 6, 1900.

"Messrs. Elizabeth City Cotton Mills, Elizabeth City, N. C.—Gentlemen: Replying to your favor of the 4th inst., would say that, in conformity with our conversation and my correspondence, I do not consider that I have any contract with you; hence there will be no descriptions or delivery instructions forthcoming.

"Yours very truly,

Oscar D. Loeb.

"Dic. O. D. L."

Even if this part of the correspondence were alone to be considered, it would not clearly appear that the relation of seller and buyer was intended to be created, for it includes several expressions (see especially the letters of March 22, 1900, and April 3, 1900) which, upon the assumption of such intent, would seem to be palpably incongruous, but which, with reference to the establishment of the relation of principal and sales agent, are plainly pertinent and quite intelligible. Yet the court below was asked to exclude all the letters prior to that of March 21, 1900, as well as the contemporaneous conversations of the parties, and to hold that a contract of sale was conclusively shown by this ambiguous and arbitrarily selected portion of the continuous and connected correspondence. We are of opinion that the learned judge was clearly right in declining to do this, and in receiving and submitting to the jury the correspondence and conversations as an entirety. The question was as to the true nature of the transaction which the parties had had under consideration, and, for the correct determination of that question, it was essential that all that had passed between them upon the subject should be known. The letters, and the conversations to which they presumably related or expressly referred, were therefore rightly admitted, and, being both admitted, their effect as a whole was properly left to the jury; and we may add that, in our judgment, its verdict for the defendant was the only one which could reasonably have been rendered.

The judgment of the circuit court is affirmed.

HINES v. TEXAS & P. RY. CO.

(Circuit Court of Appeals, Fifth Circuit. December 9, 1902.)

No. 1,187.

1. RAILROADS—INJURY AT CROSSING—CONTRIBUTORY NEGLIGENCE.

The driver of a team who, after crossing a side track filled with box cars, which obstructed the view, drove upon the main track of a railroad 50 feet distant, without looking or listening for a train, was guilty of negligence as matter of law.

In Error to the Circuit Court of the United States for the Western District of Texas.

Millard Patterson and C. N. Buckler, for plaintiff in error.

B. G. Bidwell and T. J. Freeman, for defendant in error.

Before PARDEE and SHELBY, Circuit Judges, and BOARMAN, District Judge.

PER CURIAM. Fifty feet north of the main track of the Texas & Pacific Railway at Pecos City was a side track occupied to the westward of the public crossing with box cars. The plaintiff's driver, intending to cross both tracks from the northward, stopped, and looked and listened, just behind the box cars, but heard nothing. After safely crossing the side track he attempted to cross the main track, and, although the view of the main track was clear and unobstructed, he neither looked nor listened until it was too late. He was certainly guilty of negligence.

The judgment of the circuit court is affirmed.

 UNITED BLUE-FLAME OIL STOVE CO. v. GLAZIER.

(Circuit Court of Appeals, Sixth Circuit. November 15, 1902.)

No. 1,097.

1. PATENTS—REISSUE—DELAY INVALIDATING.

A delay of more than five years, before applying for a reissue on the ground of inadvertence, accident, or mistake, invalidates the reissue, unless excused by special circumstances.

2. SAME—OIL STOVES.

The Ewert reissue patent No. 11,607 (original No. 361,934), and the Jeavons reissue No. 11,601 (original No. 463,629), each relating to blue-flame oil stoves, are void for excessive and unexcused delay in applying for such reissues, and also for anticipation of the original patents by one or more of the Morrill patents, Nos. 44,548, 55,033, and 60,224.

3. SAME—INFRINGEMENT.

The Blackford reissue patent No. 11,592 (original No. 518,305), for a vapor burner, claim 9, if it exhibits invention, is limited by the prior art to the specific structure claimed. As so limited, *held* not infringed.

Appeal from the Circuit Court of the United States for the Southern Division of the Eastern District of Michigan.

In Equity. Suit for infringement of reissue patent No. 11,607 (original No. 361,934) granted to Otto Ewert June 15, 1897, reissue

No. 11,601 granted to William R. Jeavons May 18, 1897, and reissue No. 11,592 granted to Atwell J. Blackford March 2, 1897, each for improvements in vapor burners. From a decree dismissing the bill, complainant appeals.

The following is the opinion of the circuit court, by SWAN, District Judge:

This suit involves oil and gas cook stoves having burners adapted to utilize oil as fuel and to burn the same with a blue flame. There are in use three types of blue-flame cook stoves. The first is designed to burn gasoline, the second to burn gas, and the third to burn oil. Each of these types aims to burn its fuel with a blue flame, in distinction from a white or yellow flame. Previously to the patents in suit, cook stoves adapted to burn kerosene or gasoline, and others designed to burn gas, had been in use for many years. There were also many prior patented devices for the same purpose. The blue flame evidences a more complete chemical combination of the carbon atoms of the fuel with oxygen than that effected by the white or red flame. The merits claimed for the blue flame in all constructions are that a cooking utensil may be placed directly thereon without coating the vessel with the black free carbon atom commonly called "soot," and by bringing the cooking utensil in direct contact with the flame the best application of the heat to the utensil is obtained. The bill in this cause alleged the infringement of four inventions secured by letters patent, but by stipulation one of these was eliminated from the cause. The patents which are now before the court, and alleged to be infringed by the defendant, are the Ewert reissue No. 11,607, June 15, 1897, claims 3 and 5; Jeavons' reissue No. 11,601, May 18, 1897, claims 5, 6, and 7; and the Blackford reissue No. 11,592, dated March 2, 1897, claim 9.

As regards each of these three patents and their originals, the bill makes identically the same averments, to wit: The original patent was inoperative or invalid by reason of defective or insufficient specification, or by reason of the patentee claiming as his own invention more than he had a right to claim as new; that such error arose by inadvertence, accident, or mistake, and without any fraudulent or deceptive intention; that upon due application therefor, and upon surrender and cancellation of said original patents, new patents for said respective inventions were issued in accordance with the corrected specifications for the unexpired part of the term of said original patent. The answer denied the foregoing averments of the bill relative to said reissues and their originals, and also averred, concerning each of the reissues, in substance as follows: (1) Its claim was expanded and broadened upon the invention claimed by its original patent. (2) Its claim embraced inventions different from that claimed in the original patent. (3) During the years intervening between the issue of the original patent and the reissue, independent parties entered upon the manufacture of burners which were within the scope of the reissue claimed, but were not within that of the original patents. (4) Whatever right to the reissue might ever have existed had been abandoned by reason of delay in applying for such reissue. The defendant also insists that the bill, based on six claims of three different patents, is multifarious, unless the six inventions be found in the alleged infringing construction. It may be conceded that the labors of court and counsel are increased by the presentation in a single bill of so many different issues, yet it is not clear that this single suit would entail more labor than separate suits upon each patent.

The Ewert patent sued upon is dated June 15, 1897, and is a reissue of his original patent No. 361,934, dated April 26, 1887. The latter contained but one claim, which reads as follows: "In a vapor burner of the Argand variety, the combination, with perforated tubes located, respectively, inside and outside the wick, as shown, of a diaphragm made to extend laterally across the inner perforated tube, substantially as set forth." This single claim was by the reissue expanded into five claims. Claims 3 and 5 of the reissue, which it is charged are infringed, read as follows: Claim 3: "In a hydro-carbon burner, two perforated tubes and a diaphragm spanning the

bore of the inner tube below the upper end thereof, whereby a portion of said tube is made to project above said diaphragm, and a mixing space is produced in the upper end of said tube, substantially as described." Claim 5: "A vapor burner having a pair of perforated tubes forming a combining chamber, a diaphragm across the inner tube, said inner tube being provided with openings above said diaphragm through which vapor and gases from the combining chamber flow into the space over said diaphragm, substantially as described." Morrill's patent of 1864, and his two patents of 1866, and the Ewert, the Jeavons, and the Blackford reissues, all show, as elements of the patented devices, two perforated concentric combustion tubes, with a combining chamber between them, and a diaphragm, perforate or imperforate, across the inner tube at or near its top. Ewert's has an imperforate diaphragm which spans the inner tube below its top, designed "to arrest the current of air passing up through the inner tube and force it into the combining tube." Jeavons' shows alternatively a convex or concave diaphragm located at or near the top of the tube, and having either a central opening or several openings around its center. In Blackford's construction there are connected movable tubes and diaphragm having a central opening, and located variously near the top of the tube, and above this diaphragm an extension of the inner tube, which is partly imperforate, with large openings through its walls around its top. Morrill's constructions will be adverted to hereafter. The original Ewert patent was formally offered in evidence at the hearing. Notice that it would be put in evidence by the defendant had been given during the taking of the testimony. Its admission at the hearing was within the discretion of the court. It could not have occasioned any surprise to complainant and wrought it no injury. No application was made for leave to adduce testimony relative to the identity of the invention in the original and the reissue, nor was it claimed that the admission of the original patent could operate to the prejudice of the complainant. It was, in fact, for the complainant to show that the original contained substantially claims 3 and 5 of the reissue (*Hoskin v. Fisher*, 125 U. S. 221, 8 Sup. Ct. 834, 31 L. Ed. 759); and under the pleadings it was admissible (*Oregon Imp. Co. v. Excelsior Coal Co.*, 132 U. S. 215, 10 Sup. Ct. 54, 33 L. Ed. 344).

The first inquiry is naturally the validity of the Ewert reissue, granted June 15, 1897, on an application filed May 18, 1897. This long delay, the fact that defendant and others as early as 1896 had engaged in the manufacture of blue-flame stoves which were not invasions of the invention secured by the original patent, and the enlargement in the reissue of that invention, warrant the claim that in themselves, separately and collectively, these facts are fatal to the validity of the reissue. As has been said, Ewert's original patent was granted April 26, 1887. The reissue was asked and made over 10 years later. The rule of diligence, in applying for the benefit of the statute authorizing the reissue of a patent for inadvertence, accident, or mistake, is laid down in *Topliff v. Topliff*, 145 U. S. 156-170, 12 Sup. Ct. 825, 36 L. Ed. 658, and prescribes "that due diligence must be exercised in discovering the mistake in the original patent." In that case the doctrine is reiterated that while the courts will not review the decision of the commissioner upon the question of inadvertence, accident, or mistake, unless his error is made manifest by the record, yet it is a question of law for the court, in most, if not all, cases, whether the application for reissue was made within a reasonable time. The prior decisions upon this point are collated in the opinion, and it is superfluous to cite them here. The case states the essentials to a valid reissue, viz.: (1) Identity of the invention it claims with that which appears from the specifications and claims of the original patent. (2) Due diligence in discovering the mistake in the original patent; the lapse of two years, when enlargement of the claim is sought, being ordinarily evidence of abandonment of the new matter to the public. In *Wollensak v. Reiher*, 115 U. S. 96, 5 Sup. Ct. 1137, 29 L. Ed. 350, it was held that the settled rule of decision is "that if it appears, in cases where the claim is merely expanded, that the delay has been for two years or more, it is adjudged to invalidate the reissue, unless the delay is accounted for and excused by special circumstances which show it to be not unreasonable."

In *Miller v. Brass Co.*, 104 U. S. 350, 26 L. Ed. 783, where the suggestion of inadvertence or mistake was that the claim was not as broad as it might have been, it was said by Mr. Justice Bradley: "This mistake, if it was a mistake, was apparent on the first inspection of the patent, and, if any correction was desired, it should have been applied for immediately." The foregoing cases, and those of *Ives v. Sargent*, 119 U. S. 652, 662, 7 Sup. Ct. 436, 30 L. Ed. 544, and *Mahn v. Harwood*, 112 U. S. 354, 363, 6 Sup. Ct. 451, 28 L. Ed. 665, hold that it is incumbent upon the party claiming under a patent reissued after the lapse of two years from the issue of the original patent to excuse the delay by proof of special circumstances.

Without multiplying authorities to the necessity for prompt action in seeking the correction of a defective patent, it is sufficient for this case that Ewert's long delay before applying for the benefit of the statute is neither explained nor extenuated. Prima facie it is fatal to the reissue, and conclusively so in the absence of excusatory facts. Comparison of the original with the reissue makes manifest that the purpose of the latter was, not to correct a defect of the original, but to bring within its compass matters it neither disclosed nor suggested. There is not a hint in the original of the mixing chamber or space which is made a prominent element in the reissue. This function of the inner tube above the diaphragm was clearly an afterthought, not a concept of his original device. *Freeman v. Asmus*, 145 U. S. 239, 12 Sup. Ct. 939, 36 L. Ed. 685. In the original he described and claimed what he called "improvements in vapor burners of the Argand variety." In claims 3 and 5 of the reissue he discards this limitation, and broadly claims monopoly for his arrangement of parts in all hydro-carbon and vapor burners. All beyond claims 1 and 2 of the reissue are obvious enlargements of the claim of the original patent, which disclosed their absence from it to the most careless reader. Ten years' meditation could make it no plainer. Nor does there seem to be any invention in the original device. The concentric perforated combustion tubes were in use before 1864, as Morrill admitted in his 1864 patent. Their combination with a diaphragm is shown in Morrill's patent of 1864, with three alternative constructions, viz., a cone-shaped plug, an imperforate diaphragm, and a foraminous diaphragm at the top of the inner tube. Morrill's first patent in 1866 shows a dome-shaped diaphragm, the base of which is just below the top of the inner tube, and his later patent of that year shows a pointed dome-shaped closure of the same tube with a central opening. The only departure from Morrill's first construction made by Ewert's first patent was to locate the imperforate diaphragm "usually near the top of the perforated inner tube * * * to arrest the current of air passing up inside the burner [inner tube] and deflect the same into the flame," to use the language of his specifications in the original, which make no reference to Morrill's patent, which had evidently escaped Ewert's attention and that of the patent office. In the reissue Ewert makes a labored attempt to differentiate his device from Morrill's; but it is directed to the new features of the reissued patent, rather than to the patentability of his first construction. The Ewert patent, for these reasons, does not sustain the complainant's case.

The Jeavons Reissue.

This patent is also vulnerable because of laches in obtaining it. The original was granted November 24, 1891. On an application filed April 8, 1897, a reissue was had dated May 18, 1897, after the lapse of nearly 5½ years from the issue of the original. The proofs show no excuse, nor is any pleaded for this delay, which, though not for so long a period as Ewert's, is unexcused,—equally effective to defeat the patent. The pleadings challenge the validity of the reissue, and it is incumbent upon the complainant to explain the delay "by proof of special circumstances." *Mahn v. Harwood*, supra; *Ives v. Sargent*, supra; *Hoskin v. Fisher*, supra; *Wollensak v. Sargent*, 151 U. S. 228, 229, 14 Sup. Ct. 291, 38 L. Ed. 137. All the objections which obtain to Ewert's reissue, because of his laches, are of equal force against Jeavons'. While this conclusion eliminates the Jeavons reissue from the suit, it is perhaps due to the labors of counsel and the importance of the case that the Jeavons reissue should be considered in-

trinsically, lest possibly another view might be taken of his laches. Claim 1 of Jeavons' original patent reads as follows: "In a vapor burner, a pair of perforated tubes having a combustion chamber between them, and a partition at the top of the inner tube having a passage to allow a limited quantity of air to flow through the same, substantially as described." Claim 2: "A vapor burner, provided with perforated combustion tubes in combination with a partition closing the upper end of the inner tube and having one or more air openings, substantially as described." By the reissue, claim 5 thereof was enlarged as follows: "The perforated tubes, forming a chamber between them, and a device at the upper portion of the inner tube, having a passage or passages adapted to deliver air in such volume as to maintain relatively limited combustion above said device and a closed area to shield the bodies of combustible gas flowing from the combustion chamber from currents of air from within the inner tube, and permit the said bodies of gas to commingle, substantially as described." Claim 6: "The perforated tubes forming a chamber between them, the inner tube provided with a device having an imperforate portion over which the vapor and gases from the said chamber flow and commingle, and an air passage or passages to deliver a limited volume of air to said gases over said device, substantially as described." The closed area mentioned in the fifth claim is an entirely new feature added to the reissue, and suggested, doubtless, by Ewert's application for a reissue, of whose patent Jeavons was part owner. Ewert's reissue application was pending in the patent office simultaneously with Jeavons'. The sixth claim of his reissue is also an enlargement of the second claim of his original, and of the same nature, though not as clearly stated as in the addition made to his fifth claim in the reissue. His seventh claim is not infringed, as defendant's diaphragm is located below the upper end of the inner tube.

Referring, in his specifications, to two only of Morrill's constructions, which show "both a foraminous cup or plate across the top of the inner tube and, as a modification, a solid plug set into said tube," he ignores Morrill's second patent of 1866. After mentioning Ewert's, he argues that "experience has demonstrated that the secret of perfect combustion under the best conditions yet developed in burners lies clearly between those several constructions,—Morrill's and Ewert's." Did he fathom this "secret" by original means? The defects of the Morrill burner he states to be: (1) Excessive supply of air through the foraminous diaphragm; (2) that the air is supplied over the entire surface of the diaphragm; (3) that no mixing place is left for the gases. He condemns Ewert's "improvement," because "it leaves a dead cooling place for the gases, when they drop to a temperature below the combining point with oxygen." "My invention," he says, "anticipates and remedies these defects by means of the air resisting, checking, or impeding device, partition, or plate, substantially as shown, described, and pointed out in the claims." He refers to Figs. 1, 2, 3, and 4 of his drawings of the various forms of this device, which in the art is termed a "diaphragm." He further says: "This device [diaphragm, D] may, of course, have any one of the forms shown, or such other form as would operate with like effect, or be the equivalent thereof in effect or operation, provided that the imperforate part of the plate, D, is from about the center thereof to its edge, and so constructed as to have a shielded combining space as well as an air supply." This device, like Ewert's, is purely an old combination of old elements. He used the same means to facilitate combustion as those employed by Morrill, varying the form of Morrill's diaphragm of 1864, but adopting the central opening in the diaphragm shown in Morrill's second patent of 1866. He reduced the number of perforations in the former; but it is nevertheless a perforated or foraminous plate or partition, which serves to admit air for the combustion of the gases or vapors. He changed the hemispherical diaphragm with a single central opening, shown in Morrill's second patent of 1866, into convex or concave caps having one or more openings. Jeavons terms this diaphragm, D, "with one or more relatively small passages or openings at or near its center," with the imperforate portion or area thereof, "a distinguishing and novel feature of this device, D." Morrill, by the number of the perforations of his first patent in 1866, may have

unduly reduced the imperforate area in the diaphragm, and by so much the effectiveness of the so-called "mixing space," if that is a meritorious feature. This, however, is not necessarily the result, but is dependent upon the size, as well as the number, of the holes in the plate. If Jeavons' burner effects a better combustion of the gases or vapors with the oxygen, it is apparent that it does it by substantially the same means as Morrill's. The development by experiment of a medium between a wholly imperforate diaphragm and one perforated with one or more openings is a mere carrying forward of Morrill's idea,—the step forward of a skilled mechanic. The difference between the results obtained by the two constructions is at most a question of degree, and its achievement by substantially the same means is not invention. *Smith v. Nichols*, 21 Wall. 112, 119, 22 L. Ed. 566; *Burt v. Evory*, 133 U. S. 349, 10 Sup. Ct. 394, 33 L. Ed. 647; *Grant v. Walter*, 148 U. S. 553, 13 Sup. Ct. 699, 37 L. Ed. 552.

Had Jeavons been first in the field with his patented construction, Morrill's diaphragm would clearly have infringed it. Jeavons, being 33 years later, originated nothing patentable in changing the number or size of the perforations of this partition. Equally without originality, and unsuggested by his original patent, is his "closed area to shield the bodies of combustible gas flowing from the combustion chamber from currents of air from within the inner tube and permit the said bodies of gas to commingle, substantially as described." This is elsewhere in Jeavons' reissue described as "the dead space over the device, D" (the diaphragm), which he says serves an important purpose, in that "it becomes a common mixing ground for the unequal and inadequately combined gases." This alone he admits is insufficient, because, in the absence of perforations, combustion is limited to the outer or peripheral surface of that body of gas on the upper side of the diaphragm. To produce what he calls "a distinct body of flame centrally in the body of the gases and enveloped thereby," he adopted the perforated diaphragm. The end sought was effected by Morrill's foraminous diaphragm, or that of 1866 having a central opening, whether with as "good and satisfactory results" or not is of no moment for the reasons stated. Jeavons merely decreased the number of openings in Morrill's closure, which he variously located at "the top of the inner tube" (claim 1), "closing the upper end of the inner tube" (claim 2), "spanning the inner tube at its upper portion" (claim 3), "spanning the inner tube" (claim 4), "at the upper portion of the inner tube" (claim 5), "the inner tube provided with a device having an imperforate portion, substantially as described" (claim 6), and "at the upper end of the inner tube" (claim 7). The upper side of this variously located plate or partition he called a "mixing chamber" or "mixing ground." This name and idea he apparently owes to Ewert, of whose application for a reissue, filed May 18, 1897,—the date of Jeavons' reissued patent,—the latter seems to have had ample knowledge before it was filed, and of which he was part owner. In short, Ewert appropriated Morrill's imperforate closure for the inner tube, slightly changing its position, while Jeavons made Morrill's foraminous cap of 1864 less foraminous, and gave it a sweeping and varying relation to the top of the tube, and without change adopted Morrill's central opening diaphragm of 1866. Neither Ewert nor Jeavons invented the combinations they claimed, or any of their parts. It is well argued that, if either were inventors, defendant could not have in the same structure the several arrangements of the patents sued upon.

The Blackford Reissue.

Only the ninth claim of this patent is made the subject of testimony by complainant. That claim reads as follows: "The burner, and connected inner and outer perforated combustion tubes, having a chamber between them, the inner tube being provided with a diaphragm in its upper end, having a central air opening or passage, and the said inner tube extended above the outer tube, and having a series of large openings about its top, above said diaphragm, said inner tube being imperforate between said diaphragm and said openings, substantially as described." This claim, omitting the single word "connected," qualifying the relation of the combustion tubes, when compared with Jeavons' claim, shows the same elements arranged

substantially in the same way as in Jeavons', Ewert's, and Morrill's vapor burners to and including the word "passage" in line 5 of the claim. What follows that word in the claim, and the qualifying word "connected" referred to above, define the extent to which Blackford has in claim 9 varied the form of the parts used by his predecessors in the art. Specifically, his variations are: (1) He limits the claim to a device having "connected combustion tubes." This limitation is of the essence of the alleged improvement; for in his specifications, after describing the means of connection and claiming other equivalent means, etc., he says: "This construction makes it easy and convenient for replacing the tubes, as for trimming the wick or lighting the burner." In the specifications he sets forth the advantages and various methods of moving and adjusting the connected combustion tubes and modifications of the constructions, delineated in Figs. 3 and 4 of the drawings. Ewert's patent, No. 334,166, shows an inner perforated tube supported by radial wire arms to the outer tube. (2) The extension of the inner tube above the outer tube. (3) The inner tube, having a series of large openings about its top and above said diaphragm. (4) The inner tube imperforate between the diaphragm and said openings about its top. None of the elements in claim 9 are separately claimed, and they are, therefore, not within the monopoly of the patent. *Rowell v. Lindsay*, 113 U. S. 97, 5 Sup. Ct. 507, 28 L. Ed. 906. It is true that the connection of the tubes is not essential to the combustion of the vapor or gases; but Blackford makes it an element of claims 8 and 9 of his patent, and, as the latter is the basis of the charge of infringement, all its elements must be found in defendant's construction to sustain that charge. *Rowell v. Lindsay*, supra; *McCormick Harvesting Mach. Co. v. Aultman, Miller & Co.*, 16 C. C. A. 259, 69 Fed. 371; *Muller v. Lodge & Davis Mach. Tool Co.*, 23 C. C. A. 357, 77 Fed. 621.

The common aim of all manufacturers is perfect combustion of the vapor or gases, and to this end all constructions have employed in varied form the principle of the familiar Bunsen burner for the production of intense heat. The history of the art, and in particular the various burners in evidence in this case, demonstrate that the means, forms, and arrangements of parts and their several functions in all these constructions are substantially the same. Each element in Ewert's, Jeavons', and Blackford's vapor burners performs the same functions, and each holds to other parts of the construction the like relation as its prototype in Morrill's devices and others prior. The claim sued upon,—if it exhibits invention,—independent of the objections sustained as to the Ewert and Jeavons reissues, cannot be regarded as broad or meritorious, but must be confined to the precise construction claimed. Thus construed, it is evident that defendant's burner differs essentially from the subject of Blackford's ninth claim, which describes and illustrates only the burner having its combustion tubes "connected with one another," as his specifications state, for the purpose and in the manner set forth in the patent,—not connected to the shell of the burner as in the defendant's manufacture. This is confirmed by the words "substantially as described," at the end of the ninth claim, which clearly limits the connection to the described junction of the tubes to each other. In defendant's device the tubes are secured in place by two rods at right angles, passing through their diameters, fastened at each end to the shell of the burner. Thus held radially, the tubes cannot be removed for any purpose without destroying the construction. This feature of removability of the tubes, and the device for raising or lifting them for lighting and other purposes, is a prominent factor of utility and convenience upon which Blackford dilates. Defendant's radial fastenings to the shell negative the possibility of interchanging his connections with those of Blackford. This radial difference of construction is not the equivalent of Blackford's intertubal connection, but excludes defendant's device from the compass of Blackford's ninth claim by defeating the declared function of that connection. *Fay v. Cordesman*, 109 U. S. 408, 417, 419, 3 Sup. Ct. 236, 27 L. Ed. 979, presents a case much like this. It was a suit in equity brought for the infringement of three letters patent. The third patent was for an improvement in band-sawing machines. Infringement of the first and other claims of this patent was alleged. The first claim read as follows: "(1) The frame, A, A', A", in combination with the lower arbor bearing,

said frame being constructed as herein described, and with a depression, A''', permitting a ready removal of the arbor, as explained." The court, in its opinion by Mr. Justice Blatchford, thus held: "As to claim 1, it is for the combination of the three sided frame, A, A', A'', with the lower arbor bearing, when the frame is constructed with a depression, A''', intervening between the columns, A' and A'', which leaves exposed a seat which is entirely open upward, so as to give convenient access to the lower arbor bearing, to attach, inspect, and regulate it, and also detach it, with its journal box, by lifting the arbor and journal box bodily upward, without removing the pulley from the arbor. In the defendant's machine the seat is not entirely open upward, and there is a hole through the body of the frame to receive the lower arbor bearing, and the arbor bearing cannot be removed without detaching the pulley from the arbor. This claim is not infringed." On page 420, 109 U. S., and page 244, 3 Sup. Ct., 27 L. Ed. 979, it is further said: "The claims of the patent sued on in this case are claims for combinations. In such a claim, if the patentee specifies any element as entering into the combination, either directly by the language of the claim, or by such a reference of the descriptive part of the specification as carries such element into the claim, he makes such element material to the combination, and the court cannot declare it to be immaterial. It is in his province to make his own claim, and his privilege to restrict it. If it be a claim to a combination, and be restricted to specified elements, all must be regarded as material, leaving open only the question whether an omitted part is supplied by an equivalent device or instrumentality."—citing *Water Meter Co. v. Desper*, 101 U. S. 332, 25 L. Ed. 1024, and *Gage v. Herring*, 107 U. S. 640, 2 Sup. Ct. 819, 27 L. Ed. 601.

It has not been found necessary to consider the defense that Blackford was not the inventor of the device covered by his patent. For the reasons stated, the bill must be dismissed, with costs.

Thomas B. Hall, for appellant.

C. F. Burton, for appellee.

PER CURIAM. This is a bill for infringement of three reissue patents, all belonging to complainant below and all being for invention adapted to burn kerosene oil with a blue flame in a cook stove. The court below held that reissue patent No. 11,607 to Otto Ewert, and the reissue of patent to Wm. R. Jeavons, No. 11,601, were void for excessive and useless delay in the applications for such reissue, and also that the original claim carried into the reissued patents to each were void for anticipation in the three Morrill patents, Nos. 44,548, 55,033, and 60,224, and that the reissued Blackford patent, No. 11,575, was so narrowed and limited as to be at most good for the specific structure claimed and described, and that, so limited, the defendant does not infringe. Upon the opinion of District Judge SWAN, as to the points mentioned, this court affirms the decree of the court below.

UINTA TUNNEL MIN. & TRANSP. CO. v. CREED & CRIPPLE CREEK
MIN. & MILL CO.

(Circuit Court of Appeals, Eighth Circuit. November 18, 1902.)

No. 1,762.

1. MINING—TUNNEL-SITE CLAIMANT NEED NOT ADVERSE LODGE CLAIM.

The claimant of a tunnel site located across lode claims is not required by sections 2325, 2326, Rev. St. [U. S. Comp. St. 1901, pp. 1429, 1430], to file an adverse claim, when applications for patents of the lode claims are made, in order to protect his rights in those cases in which his inter-

est in the lode claims is so uncertain, contingent, and intangible that it cannot be fairly litigated when the applications are made.

2. SAME—PATENTS OF LODE CLAIMS SUBJECT TO RIGHTS OF CLAIMANTS OF TUNNEL SITES LOCATED BEFORE THE ENTRIES.

Patents of lode mining claims based on entries made after the location of a claim for a tunnel site across them are subject to the rights of the claimant of the tunnel site in cases in which his rights therein were so uncertain, contingent, and intangible that they could not be fairly litigated when the applications for the patents were made.

3. SAME—LAND DEPARTMENT—ENTRIES AND PATENTS—ESTOPPEL.

The judgments of the land department permitting entries of land and the patents based upon those entries bind all the parties to the proceedings which resulted in them and all those claiming interests acquired from such parties subsequent to the entries. But they do not estop those who were not, and were not required to be, parties to the proceedings from establishing by the customary evidence the truth relative to any fact material to their claims in any litigation between them and the holders under the patents.

4. SAME—ENTRIES AND PATENTS OF LODE CLAIMS—NO ESTOPPEL OF THE OWNER OF PRIOR TUNNEL CLAIM.

Entries and patents of lode mining claims in proceedings to which a claimant of a tunnel site, located across them prior to the entries, was not, and was not required to be, a party will not estop him from establishing by the testimony of witnesses who know, and by other customary evidence, the fact that no discoveries of lodes or mines of mineral had been made in the lode claims before the claim for the tunnel site was located across them.

5. SAME—CERTIFICATES OF LOCATION—EVIDENCE OF RECITALS.

Certificates of location of mining claims are not conclusive evidence of the facts which they recite against parties who claim the land they describe adversely to their makers.

(Syllabus by the Court.)

In Error to the Circuit Court of the United States for the District of Colorado.

The writ of error in this case challenges the trial of an issue involving the rights of the respective parties to the action to the possession of the space within the bore of a tunnel where it passes through two lode mining claims beneath the surface of the earth. The Creede & Cripple Creek Mining & Milling Company was the plaintiff, and the Uinta Tunnel Mining & Transportation Company was the defendant, in the action below, and they will be so styled in this statement and in the opinion which follows. The plaintiff was the owner of two lode mining claims called the Ocean Wave and the Little Mary, which were entered for patent on August 5, 1892, and were patented on December 21, 1893. The plaintiff alleged in its complaint that these claims were duly located and discovered on January 2, 1892. The defendant was the owner of a claim to a tunnel site which extended through these lode claims beneath the surface of the earth, and which was located on January 13, 1892. It also owned certain lode claims which had been located on blind veins that had been discovered in the tunnel after the lode claims of the plaintiff had been patented. The mining claims of the plaintiff were between the portal of the tunnel and the defendant's lode claims, and the latter had driven its tunnel through the plaintiff's claim, and was using it as a way to bring to the surface of the earth the ore it was extracting from its blind veins. The real issue was whether or not the defendant had the right of way along the bore of its tunnel through the lode claims of the plaintiff, and the determination of this issue depended upon the priority of their respective claims. The plaintiff asserted that its claims were discovered and located on January 2, 1892. The defendant averred that its tunnel was located on January 13, 1892, and that no discovery of mineral in rock in place was

¶ 5. See Mines and Minerals, vol. 34, Cent. Dig. § 50.

made within the lode claims of the plaintiff until after its tunnel site was located. These averments of the defendant were stricken from the answer, and the evidence which it offered to sustain them was rejected. Exceptions were taken to these rulings, and there was a verdict and judgment for the plaintiff.

Gerald Hughes and Scott Ashton (Charles J. Hughes, Jr., on the brief), for plaintiff in error.

H. H. Lee (C. S. Thomas, A. T. Gunnell, W. H. Bryant, T. M. Patterson, E. F. Richardson, and H. N. Hawkins, on the brief), for defendant in error.

Before CALDWELL, SANBORN, and THAYER, Circuit Judges.

SANBORN, Circuit Judge, after stating the case as above, delivered the opinion of the court.

When the claim to a tunnel site has been located before the entry of the conflicting lode mining claims which have subsequently passed to patents, is the question whether discoveries of mineral in rock in place were made within the lode claims before the location of the claim to the tunnel site open to determination by means of evidence or testimony *dehors* the patents? This is the principal question presented by this record. If the query were whether or not it is competent to show by proof outside the receiver's receipts or the patents that there had been no location of the patented claims or no discovery of the lodes therein before they were entered for patent, there would be no doubt that a negative answer must be returned to the question for the reason that this is an issue between the parties to a proceeding before the land department which that tribunal necessarily considers and decides when it permits the entries of the lands, and its decisions of questions within its jurisdiction are impervious to collateral attack. *King v. McAndrews*, 111 Fed. 860, 863, 50 C. C. A. 29, 32. This was the question which the supreme court answered in *Calhoun Gold Min. Co. v. Ajax Gold Min. Co.*, 182 U. S. 499, 502, 503, 510, 21 Sup. Ct. 885, 45 L. Ed. 1200; and while, if the language of the opinion in that case is carelessly read without knowledge of or reference to the question actually before the court, it may seem to be broader, a careful examination of the facts which the record there discloses demonstrates the proposition that the decision went no further. In that case the receiver's receipts on the lode claims of the appellee had been issued before the claim to the tunnel site was located. Page 502, 182 U. S., and page 887, 21 Sup. Ct., 45 L. Ed. 1200. In a proceeding between the lode claimants and the United States the land department had decided that mineral in place had been discovered within the claims and had permitted their entry. Subsequent to this decision and to these entries the owner of the claim to the tunnel site located it across the lode claims, and upon the trial offered to prove that there had been no discovery of mineral in place within those claims before they were entered. The trial court rejected the offer. The supreme court said: "The ruling was right. The patents were proof of the discovery, and related back to the date of the locations of the claims. The patents could not be collaterally attacked." Thus, it may be seen that the only proposition there decided was that one who had

initiated no claim upon lands when they were entered by other claimants could not subsequently collaterally attack the decision of the land department that there had been a discovery of mineral in place upon the claims at some time before they were entered.

Counsel for the plaintiff rely upon the decision and opinion in this case, and insist that it fairly sustains the rulings of the court below. But there are radical and controlling differences between the question presented in that case and the issue of law before us in the case in hand.

1. A judgment is binding upon the parties to the proceeding in which it is rendered and upon their privies. The parties to the judgments of the land department by which it allowed the entries of the lode claims in the case of the gold mining company were the United States and the owners of those claims. No other parties had or claimed any interest in the land at the time those entries were made. The judgments and the patents accordingly bound and estopped these parties and their subsequent assignees. They estopped all parties who initiated claims upon or interests in the lands under either of the parties to the proceeding subsequent to the judgments of the land department. The claimant of the tunnel site in that case initiated its claim under the United States, one of the parties to that proceeding, subsequent to the judgments. It was therefore a privy of the United States, and was estopped by the judgments of the land department from proving that no discoveries had been made upon the lode claims before these judgments were rendered. This is not the case in the action before us. The claim to the tunnel site was located on January 13, 1892. The judgments of the land department allowing the entries were rendered on August 5, 1892. At that time there were three parties interested in the land,—the lode claimants, the United States, and the claimant of the tunnel site. Two of these parties, the lode claimants and the United States, were parties to the proceedings, and were estopped by the judgments and the patents. One of them was not a party to any of these proceedings, to the judgments, or to the patents, and, upon familiar principles, was neither bound by them nor estopped by them from presenting and proving according to the established rules of evidence in trials under the common law the fact that no discoveries had been made on the lode claims before the location of its tunnel site, the fact essential to the validity of its claim upon and interest in the land.

Not only was the claimant of the tunnel site not a party to the proceedings in the land department which resulted in the entries and patents to the lode claims, but it was neither required to become such a party nor to submit its claims and interests in the lands to the adjudication of that department at that time because its rights therein were then too uncertain, contingent, and intangible for determination. When the applications for the patents of the lode claims were filed, the blind veins which have induced the use of the tunnel through the lands in controversy had not been discovered, the tunnel had not been driven into the land, and it was impossible to know whether or not the claimant of the tunnel site would ever acquire any right to use this land for the purpose to which it is now devoted. The claim-

ant of a tunnel site is not required by sections 2325, 2326, Rev. St. [U. S. Comp. St. 1901, pp. 1429, 1430], to file an adverse claim and submit his rights in the lode claims it crosses to adjudication by the land department upon the filing of applications for patents to those claims when his rights are at that time uncertain, contingent, and intangible. *Enterprise Min. Co. v. Rico-Aspen Consol. Min. Co.*, 167 U. S. 108, 112, 17 Sup. Ct. 762, 42 L. Ed. 96; *Enterprise Min. Co. v. Rico-Aspen Consol. Min. Co.*, 13 C. C. A. 390, 399, 400, 66 Fed. 200, 209, 210.

2. The issue whether the discoveries in the lode claims were made before the location of the tunnel site in the Ajax Gold Min. Co. Case was necessarily considered and adjudged by the land department when it permitted the entries of the lode claims. The finding that such discoveries had been made before the date of the entries was indispensable to the decision that the lode claimants were entitled to make the entries so that that finding must have been made by the department. But the location of the tunnel site in that case was subsequent to these entries. Hence the finding that the discoveries were made before the entries was necessarily a finding that they were made before the location of the tunnel site, and it was, as we have seen, binding upon the claimant of the tunnel site, because it was claiming a right initiated after this adjudication under a party to the judgments.

It is not so in the case before us. The question here is whether or not discoveries were made in the lode claims prior to January 13, 1892, the date of the location of the claim to the tunnel site. The determination of this question was neither indispensable nor material to the adjudication made by the land department on August 5, 1892, that the lode claimants were entitled to enter the land, and there is nothing to show that this issue was ever considered or decided by that department in reaching its conclusion. The only question relative to the discoveries that it was required to determine was whether or not they had been made prior to August 5, 1892, when the entries were permitted, and the decision of that question left entirely untouched the issue in this case whether they were made before or after the location of the tunnel site on January 13, 1892.

3. When the entries were made in the Ajax Gold Min. Co.'s Case no claim to a tunnel site had been located or staked upon or across the lode claims and the entries of them, and the patents to them vested the title in the claimants free from any right or claim to a tunnel site. It is otherwise in the case at bar. The claim to the tunnel site was located and staked out across these lode claims before they were entered. Under the Revised Statutes and the law the entries and patents of these claims vested the title to them subject to the rights of the prior claimant of the tunnel site just as they vested it subject to the right of an owner of an adjoining lode claim to follow on its dip through a side line and through the patented territory of these lode claimants any vein which has its apex in his claim. *Enterprise Min. Co. v. Rico-Aspen Consol. Min. Co.*, 13 C. C. A. 390, 400, 66 Fed. 200, 210; *Mining Co. v. Campbell*, 135 U. S. 286, 301, 10 Sup. Ct. 765, 34 L. Ed. 155; *Hall v. Mining Co.*, *Morr. Min. R.* (3d Ed.).

p. 282; *Branagan v. Dulaney*, 8 Colo. 408, 412, 8 Pac. 669; *Lee v. Stahl*, 9 Colo. 208, 210, 11 Pac. 77; *Morgenson v. Milling Co.*, 11 Colo. 176, 179, 17 Pac. 513.

While, therefore, it is a flagrant attack upon a patent to attempt to maintain a claim initiated subsequent to the entry on which it rests, it is no such attack to assert the rights of the claimant of a tunnel site located before the entry of the land against a patent of it to a lode claimant, because under the statutes and the law such a patent always issues subject to those rights.

Notwithstanding all these considerations counsel for the plaintiff insist that the defendant is estopped from pleading and proving that no discoveries of mineral in place were made in the lode claims before the location of the tunnel site on January 13, 1892, because certificates of location of the lode claims were filed on January 2, 1892, which declare that such discoveries were made on that day, and it is a well-settled principle that patents relate back to and take effect upon the dates of the initiation of the rights on which they are founded.

But the certificates of location are not conclusive proof of the facts which they recite against those asserting rights adverse to their makers. They are competent evidence of the fact that they were made and filed, and hence of an important link in the chain of the plaintiff's title. But when the existence of the facts which they recite is challenged they are but the *ex parte* statements of interested parties, and there is nothing in them or in their relation to the property or the parties to bind those claiming the lands adversely to their makers or to estop them from establishing the truth by the customary oral and written evidence. Nor is there anything in the doctrine of relation to work such an estoppel. Grant that the patents relate back and take effect as of the date of the initiation of the lode claims, yet since the patents are subject to the rights of the claimant of the tunnel site when they are issued they are still subject to those rights when they have related back to the inception of the claims upon which they rest.

Moreover, the averment of the defendant is that no discoveries were made in the lode claims until after the location of its claim to the tunnel site. If this allegation is true, it may be doubted whether the lode claims can be said to have been initiated before the claim for the tunnel site was located. "No location of a mining claim shall be made until the discovery of the vein or lode within the limits of the claim located." Rev. St. § 2320 [U. S. Comp. St. 1901, p. 1424]; *Enterprise Min. Co. v. Rico-Aspen Consol. Min. Co.*, 167 U. S. 108, 112, 17 Sup. Ct. 762, 42 L. Ed. 96. It is true that subsequent discoveries may validate earlier locations, and that the latter may then inure to the benefit of the locators as against the United States and all parties whose claims were initiated subsequent to the discoveries. But they would inure to their benefit as of the dates of the discoveries, and not as of the dates of the locations, and they would neither destroy nor affect intervening rights. The marking of boundaries and filing of location certificates may precede discovery or discovery may precede them, but no location is valid until both

are complete. The earlier act then inures to the benefit of the locator as of the date of the later, subject to all rights which have intervened between them. *Erwin v. Perego*, 35 C. C. A. 482, 485, 93 Fed. 608, 611; *Jupiter Min. Co. v. Bodie Consol. Min. Co.*, 11 Fed. 666, 676, 7 Sawy. 96; 4 *Morr. Min. R.* 411, 423; *North Noonday Min. Co. v. Orient Min. Co.*, 1 Fed. 522, 531, 6 Sawy. 299; *Zollars v. Evans*, 5 Fed. 172, 175, 2 *McCrary*, 39; *Strepy v. Stark (Colo.)* 5 Pac. 111, 114; *Thompson v. Spray*, 72 Cal. 528, 533, 14 Pac. 182; *Erhardt v. Boaro*, 113 U. S. 527, 536, 5 Sup. Ct. 565, 28 L. Ed. 1116. There was therefore no valid location of the lode claims until the discoveries within them were made, and it is held by the circuit court of appeals of the Ninth circuit in *Last Chance Mining Co. v. Tyler Min. Co.*, 61 Fed. 557, 565, 9 C. C. A. 613, 621, that a patent for a mining claim only relates back to the time when a valid location was first made. If this is a correct view of the law, the patents in this case could not relate back to a time anterior to the dates of the discoveries, and if those were subsequent to the location of the tunnel site they could not affect defendant's rights.

If litigation for the possession of the property in controversy in this action had arisen between the lode claimants and the claimant of the tunnel site at a time prior to the entries of the lode claims, the question whether or not discoveries of mineral in place had been made in the lode claims before the location of the tunnel site would have been decisive of the issue, and the testimony of witnesses who knew the facts and other evidence competent in the customary trials of such issues at law would have been admissible to determine the question. What is there in the entries and the patents to deprive the defendant of its right to try this issue now upon like evidence? Its claim to this land had attached before those entries were made. It was not a party to the proceedings in the land department which resulted in the adjudication that the lode claimants were entitled to enter it. It was not required to file an adverse claim and to submit its rights to the adjudication of that department when the applications for the patents were made. The adjudication of the land department which permitted the entries was *res inter alios acta* and ineffectual to estop the defendant. The department was not required to determine and it did not decide the question here at issue, and under the statutes and the decisions of the federal courts the entries and the patents were made subject to the rights of the claimant of the tunnel site which had attached before the land department permitted the entries. Our answer to the question which this case presents is that when the claim to a tunnel site has been located before the entry of conflicting lode claims, which have subsequently passed to patents, the question whether discoveries of mineral in place were made in the lode claims before or after the location of the claim to the tunnel site was perfected is open to determination by means of the testimony of witnesses and other competent evidence dehors the patents in any litigation between the parties involving their conflicting claims. *Last Chance Min. Co. v. Tyler Min. Co.*, 61 Fed. 557, 565, 567, 9 C. C. A. 613, 621-623; *Champion Min. Co. v. Consolidated Wyoming Gold Min. Co.*, 75 Cal. 78, 16 Pac. 513; *Iron Silver Min. Co.*

v. Campbell, 135 U. S. 286, 10 Sup. Ct. 765, 34 L. Ed. 155; Davis' Adm'r v. Weibbold, 139 U. S. 507, 11 Sup. Ct. 628, 35 L. Ed. 238.

The averments that no discoveries of mineral in place within the lode claims had been made before the location of the claim to the tunnel site should not have been stricken from the answer of the defendant and its evidence to sustain them should have been received. The question which has been considered is decisive of the issue whether or not the judgment below should be affirmed, and, as the other questions presented by the assignment of errors may not arise again, they will not now be considered.

The judgment below must be reversed, and the case remanded to the court below, with directions to grant a new trial; and it is so ordered.

MASSETH v. LARKIN et al.

(Circuit Court of Appeals, Third Circuit. December 2, 1902.)

No. 17.

1. PATENTS—INFRINGEMENT.

The fact that the device of a patent was the first to accomplish a certain result does not render another an infringement merely because it accomplishes the same result, but it must do so by substantially the same or similar means.

2. SAME—DEEP-WELL PACKERS.

The Masseth patent, No. 439,166, for a packer for deep wells, claims 1 and 2, construed, and held not infringed.

Appeal from the Circuit Court of the United States for the Western District of Pennsylvania.

For opinion below, see 111 Fed. 409.

C. P. Byrnes, for appellant.

James I. Kay and George H. Christy, for appellees.

Before ACHESON, Circuit Judge, and BRADFORD, District Judge.

ACHESON, Circuit Judge. This was a suit brought by Benjamin Masseth, the grantee of letters patent No. 439,166, dated October 28, 1890, for an improvement in packers for deep wells, against William H. Larkin and John Feigel, for alleged infringement of the patent.

The purpose of a well packer is to seal the annular space between the wall of the well and the casing. The improvement of the patent in suit related to what were known in the art as "wall-packers" (that is, packers supported at intermediate points between the top and bottom of the well), and to the class of such packers known as "pressure-packers," in which the expansion of the packing material is effected by the down pressure of the casing. We extract from the specification the following description of the device of the patent, and its mode of operation: The packer consists of an expansible packing-sleeve of rubber, which fits around the casing, and is interposed between a coupling sleeve, 4, and a tubular section, 5, which latter fits telescopic-

ally around the casing, and is loosely set thereon, so as to be capable of longitudinal movement when unrestrained. This tubular section, 5, is made externally conical or wedge-shaped. A collar or band, 6, encircles the casing below the section, 5, and is provided with upwardly projecting arms, 7, having fixed thereto leaf-springs, 8, which are bowed so that their middle portions shall be adapted to bear frictionally against the sides of the hole, so that they may be moved either up or down in the hole without biting positively thereon. Section, 5, is provided with longitudinal recesses or grooves, 9, into which the ends of the arms, 7, are adapted to fit; the ends of these recesses, by engagement with the ends of the arms, 7, limiting the upward motion of the latter. When the casing is lowered into the hole the above-mentioned parts are attached to the lower end of the casing, the arms, 7, fitting in the grooves, 9, with the ends of the arms in engagement with the ends of the grooves, so as to lock the arms and to prevent them from rising on the conical section, 5. When it is desired to expand the packer, the casing is lifted somewhat, and the friction of the springs, 8, against the sides of the hole, causes the casing to rise within the collar, 6, and the ends of the arms, 7, to draw out from the grooves. The operator then turns the casing so as to bring the ends of the arms, 7, opposite the ungrooved portions of the section, 5, and the casing is allowed to descend in the well. The friction of the springs, 8, against the sides of the hole, upholds the arms, 7, and permits the casing to slip down within the arms, which rise over the conical portion of section, 5. The wedge action of the latter upon the arms spreads them, and causes them to bind in the hole, until finally their pressure against the sides of the hole becomes sufficiently strong to uphold the weight of the casing. Then the superimposed casing, acting upon the top of the rubber packing-tube, compresses the rubber longitudinally, and bulges it out against the side of the hole. The casing may be unpacked and moved in the well either up or down, and packed in another position. This is done by raising the casing sufficiently to relieve pressure on the packing-tube, when it will resume its normal cylindrical form, and by drawing up the casing still further, so as to remove the arms, 7, from the conical section, 5. Then by turning the casing the grooves, 9, will be brought into alignment with the upper ends of the arms, 7, and upon lowering the casing the arms will enter the grooves, and again become locked therein.

The claims of the patent alleged to be infringed by the defendants are the first and second, which are as follows:

"(1) In deep-well packers, the combination, with the pipes or casing and an expansible packer, of arms adapted to engage with the sides of the hole, and to hold the casing to afford resistance to the packer, and a lock for holding said arms, said lock being adapted to be disengaged by turning the casing, substantially as and for the purposes described.

"(2) In deep-well packers, the combination, with the pipes or casing and an expansible packer, of arms adapted to engage with the sides of the hole, and to hold the casing to afford resistance to the packer, a cone or wedge for expanding the arms, and a stop by which the arms are restrained from motion on the casing, and adapted to be freed from connection with the arms by turning the casing to permit the wedge to be moved within said arms to expand them, substantially as and for the purposes described."

The defendants' device is a wall-packer of the "pressure-packer" class. The characteristic parts of all such packers are a tubular section having on its surface a cone, a ring carrying slips or wedges adapted to ride on the cone and to be forced outwardly, an expandible rubber sleeve, and a telescopic section for expanding it. These parts were old in the art before the invention of the patent in suit. The defendants employ a ring carrying wedging-arms, which ring encircles the casing and freely moves up and down thereon. This ring normally rests on a sleeve which encircles the casing, but the ring is in no wise secured to the sleeve. The defendants' wedging-arms do not make contact with the sides of the well at any time while the packer is being lowered or shifted, but keep close to the casing. The sleeve has a left-hand female thread formed on its inner face, which engages with a male thread on the casing. This sleeve carries bowed strips of metal, having lugs adapted to engage with the walls of the well to hold the sleeve stationary as against rotary movement. The packing is accomplished thus: The operator, by turning the casing, pushes the sleeve upward, and thus forces the wedges at the upper ends of the arms up between the cone and the wall sufficiently to resist the weight of the casing.

The case turns upon the question of infringement. Now, upon the proofs and under the authorities, it can confidently be affirmed that, while Masseth's described improvement was meritorious and patentable, the invention was not a primary one. The patentee was not a pioneer here. The art was old when this improvement was conceived. Two classes of wall-packers had been in common use,—screw-packers and pressure-packers. The screw-packer, indeed, may not have been a perfect device, and its use may have been comparatively limited. Nevertheless it was a practicable instrumentality, whereby the expansion of the rubber packing was effected by means of screw-threaded sections at the lower end of the well tubing, operated from the top of the well by turning the tubing; and this packer, after being once set, could be moved either up or down the well, and reset. Again, the Gordon pressure-packer, after being set in the well, could be moved down and reset; and the Palm pressure-packer, after being set in the well, could be moved up and reset. All these packers preceded the invention of the patent in suit. Under the evidence it seems that Masseth was the first to devise a pressure-packer which, after being set in the well, could be released and moved either up or down, and repacked at any desired point. To accomplish this, he combined with old parts a lock—described in the specification—for locking and unlocking the upholding wedge-ended arms. What Masseth aimed at and achieved was to prevent the wedges at the ends of the arms from jamming between the cone and the wall of the well when such action is not desired; that is to say, during the lowering of the apparatus, or while it is being shifted up or down. To this end he provided restraining means to prevent the wedge-ended arms from acting when their action is not needed. He locked the arms out of action. The novelty of his apparatus is, "lock for holding said arms," as specified in his first claim, or "a stop by which the arms are restrained from motion on the casing," as specified in his second claim. The office of

Masseth's lock is aptly stated by Mr. Boyce, the plaintiff's expert, when he says:

"The function of a lock, as the word is intended in the Masseth packer, is to keep the wings [slips] from being engaged with and wedging the cone until such time as it is desired to have them engaged with the cone, and to unfasten them when it is desired to unfasten them."

Do the defendants use the Masseth lock, or the substantial equivalent thereof? That their apparatus has the capacity of readjusting the position of the packer in the well, and resetting it above or below its original position, is not decisive of the question of infringement. *O'Reilly v. Morse*, 15 How. 62, 119, 14 L. Ed. 601; *Westinghouse v. Brake Co.*, 170 U. S. 537, 569, 18 Sup. Ct. 707, 42 L. Ed. 1136. The court in the former case said:

"And any one may lawfully accomplish the same end without infringing the patent if he uses means substantially different from those described."

And in the latter case the court said:

"But after all, even if the patent for a machine be a pioneer, the alleged infringer must have done something more than reach the same result. He must have reached it by substantially the same or similar means, or the rule that the function of a machine cannot be patented is of no practical value."

Now, the defendants' ring which carries the slips or wedging-arms is normally detached and loose. The wedging-arms while out of action are free from restraint of any kind. No lock or stop is necessary to restrain the defendants' wedges or keep them out of action. The principle of the defendants' apparatus is such that normally the wedging-arms stay out of action. They are brought into action—forced up into engagement with the cone and wall of the well—by pressure exerted from below. Mr. Boyce, the plaintiff's expert, states:

"The defendants' slips are prevented from engaging with the cone in two ways: First, by their own gravity; and, second, because they have an inward spring which keeps them close to the main tube of the packer, so that they will not ride upon the cone, but must be forced up by action of the screw."

It is our judgment that neither in form nor in substance do the defendants employ the lock or stop of the patent in suit.

The argument based on the assumption that, in separating the ring which carries the slips or wedging-arms from the threaded sleeve, the defendants merely cut into two parts that which Masseth's patent shows is properly one single piece, fails, under the proofs. It plainly appears that, if the wedging-arms were attached to or connected with the threaded sleeve, the result would be an inoperative, or at least an impractical, device. The separation is not arbitrary, or even a matter of mere choice, but is absolutely necessary to the successful working of the defendants' packer. The principle of their packer requires the employment of free and independent slips or wedging-arms.

Both Masseth and the defendants have borrowed freely from the prior art, but we do not see that the defendants have borrowed anything from Masseth. The defendants' threaded sleeve, with its outwardly bowed retainers to prevent rotary movement, substantially agrees in structure and function with what we find in the Brooder

screw-packer, constructed in accordance with the Brooder patent of 1886.

Our study of this case has brought us to the conclusion that the structural differences between the packer described in the Masseth patent, and covered by the first and second claims, and the packer of the defendants, are substantial differences, and, furthermore, that in mode of operation the two packers are essentially unlike. We are of opinion that the circuit court was right in holding that there was no infringement by the defendants, and in dismissing the bill of complaint.

Accordingly the decree is affirmed.

WITHERSPOON v. OLCOTT et al.

(Circuit Court of Appeals, Fifth Circuit. December 16, 1902.)

No. 1,152.

1. PUBLIC LANDS—PATENTS—IRREGULAR SURVEY.

A patent regularly issued to state lands in Texas is not void, though the survey on which it is based was made by a surveyor working outside his regular district.

2. SAME—TRESPASS TO TRY TITLE.

A title based on a patent issued on a survey of state lands made by a surveyor outside of his district will prevail in an action of trespass to try title against a defendant claiming under an alleged prior conflicting patent, the description in which does not identify the same with the land in controversy.

In Error to the Circuit Court of the United States for the Northern District of Texas.

W. O. Davis, for plaintiff in error.

A. M. Carter and T. D. Cobbs, for defendants in error.

Before PARDEE and SHELBY, Circuit Judges, and BOARMAN, District Judge.

PARDEE, Circuit Judge. This is an ordinary action of trespass to try title, resulting in a judgment in favor of Frederick P. Olcott, defendant in error, for five sections of land in block A of formerly Hardeman, now Foard, county, patented to the Houston & Texas Central Railway Company in November, 1881, and four sections in block 44 of said county, patented to said railway company in September and October, 1877. Olcott claimed under a quitclaim deed from the receiver of said railway company,—sufficient, however, to vest in him whatever right the railway company had to said lands. The patents to the railway company were predicated upon certificates issued to said railway company on the 1st day of July, 1872, and upon surveys made by the surveyor for the Jack land district on the 25th day of September, 1872, and on the 18th day of December, 1873, which surveys were claimed to be void because Hardeman county was not in his district nor under his jurisdiction, as decided by the supreme court in *Cox v. Railway Co.*, 68 Tex. 226, 4 S. W. 455, and in other subsequent decisions. Afterwards, in November, 1874, while Hardeman county was in fact in his district and under his jurisdiction, the

surveyor for the Jack land district made surveys for other persons, more or less conflicting with the nine surveys previously made for the said railway company. While these surveys may be valid and superior to the surveys made for the said railway company, all of them are unpatented, except the B. H. Epperson survey, patented on the 8th day of May, 1876, the McGuire Chessau survey, patented on the 22d day of October, 1875, the Houston Tap & Brazoria Railway Company survey, patented on December 4, 1875, the Memphis, El Paso & Pacific Railway Company survey, patented on December 20, 1875, and the Wm. T. Dillingham survey, patented on March 16, 1876, which patents are older than the patents to the Houston & Texas Central Railway Company. The plaintiff in error introduced certified copies or sketches from the maps of Foard county in use in the land office, tending to show in some degree the nature and extent of the conflict between these surveys and the previous surveys made for the Houston & Texas Central Railway Company, but the conflict was not sufficiently shown for either court or jury to act upon same.

The court instructed a verdict for Olcott upon the theory that the patents to the railway company were not void, but certainly vested in the company the legal title to the land, as against outstanding equities in the hands of strangers, and against even superior outstanding legal title not clearly shown to conflict. The correctness of the court's instruction to find a verdict for the plaintiff below has been brought here for review, and, after full consideration, we are of opinion that there was no error in the instruction given.

Without undertaking to decide upon the much-argued question as to whether in 1872 E. Boon, a surveyor of Jack county, and of the Jack county land district, and perhaps claiming to be de facto surveyor of Hardeman county, had a right to make the surveys in Hardeman county (now Foard county) upon which the patents to the Houston & Texas Central Railway Company were based, we think it clear that the patents issued upon such surveys were not void. There is no question that the surveys were made, that they were filed in the general land office in accordance with the law, and that upon them the patents were apparently regularly issued. It seems to be well settled in Texas that patents issued under such circumstances cannot be treated as void. See *Styles v. Gray*, 10 Tex. 503, 508; *Deen v. Wills*, 21 Tex. 642; *Todd v. Fisher*, 26 Tex. 239; *O'Neal v. Manning*, 48 Tex. 403; *Johnson v. Eldridge*, 49 Tex. 507; *Gullett v. O'Connor*, 54 Tex. 408; *Gambrell v. Steele*, 55 Tex. 582; *League v. Rogan*, 59 Tex. 430; *Miller v. Moss*, 65 Tex. 182; *Decourt v. Sproul*, 66 Tex. 371, 1 S. W. 337.

The opinion of Judge Moore in *Todd v. Fisher*, *supra*, is so directly applicable to the facts in the present case that we quote the same as conclusive, as follows:

"This suit was brought by the appellees for the recovery of six hundred and forty acres of land, for which a patent was issued to them by virtue of an act of the legislature passed February 1, 1854, to enable them to perfect titles to the lands for which certificates had been issued to them under the act of January 21, 1850. The appellant insists that both these laws are unconstitutional, because, as he insists, they are in conflict with the provisions of the ordinance attached to the constitution, and that the patent was conse-

quently issued without legal authority, and is therefore absolutely null and void. It cannot be questioned that when it appears from an inspection of the patent, or the statute under which it issued, that it was unauthorized by law, or that the officer from whom it emanated did not have authority to grant it, it cannot be regarded in any case as any evidence of title. *Pollard's Heirs v. Files*, 3 Ala. 47; *Polk v. Wendal*, 9 Cranch, 87, 3 L. Ed. 665; *Patterson v. Winn*, 11 Wheat. 380, 6 L. Ed. 500. But if it emanated from competent authority, although in the preliminary proceeding upon which it is based—such, for instance, as the issuing of the certificate or making the survey—an illegality should intervene which eventuates in the grant of a patent to a party who otherwise would not have been entitled to receive it, yet as it is made by an officer authorized to make the grant, and whose duty it is to pass upon the sufficiency of the evidence on which it is issued, it appears to be held, by the great weight of authority, that the state, or some one having a color of title or equitable interest in the land, can alone attack the patent for such illegality. *Crommelin v. Minter*, 9 Ala. 594; *Hoofnagle v. Anderson*, 7 Wheat. 212, 5 L. Ed. 437; *Brush v. Ware*, 15 Pet. 93, 10 L. Ed. 672; *Jennings v. Whitaker*, 4 T. B. Mon. 50; *Hunter v. Hemphill*, 6 Mo. 119; *Sarpy v. Papin*, 7 Mo. 503; *Winter v. Jones*, 10 Ga. 206, 54 Am. Dec. 379; *Taylor v. Dougherty*, 1 Watts & S. 326; *Steiner v. Coxe*, 4 Barr, 13. If this is not so, all distinction between acts void and voidable is destroyed. But perhaps it may be said that the commissioner of the general land office has no authority to issue a patent unless the preliminary requisitions of the law have been complied with; and, if he were to do so, it consequently should be held, when this is shown, not to pass the title. Such a conclusion would subvert in a great degree the efficacy of the patent, and would leave the party in a worse condition than while his proceeding was in limine; for then, if it were held erroneous, he might correct or amend it. The question suggested, however, does not present the correct view of the matter. The commissioner has the authority or power, as the granting officer, but should not issue the patent unless the party is shown to be entitled to it. Neither should a court give an erroneous judgment. But could the commissioner, it may be asked, issue a patent to any one whom he might fancy, without a certificate or survey? Perhaps not. He probably would have no more authority to issue a patent without a certificate and survey, of apparent validity upon inspection, than a court has to render a judgment without a petition. But if a certificate and survey are presented to him, and he has acted upon them, it would seem that his decision, though erroneous, should be conclusive upon all parties, except the state, or those who have some color of title to or interest in the land."

There does not seem to be any dispute that an outstanding equity will not avail a stranger in defense against the legal title. See *Shields v. Hunt*, 45 Tex. 435, and *Gullett v. O'Connor*, supra.

The two certified land-office sketch maps introduced in evidence by the defendant in the court below may show to the initiated a conflict, and the extent thereof, between the patents issued to the Houston & Texas Central Railway Company and the prior patents to Dillingham, Epperson, McGuire, Chessau, and others; but, from our examination, no court or jury could tell therefrom the extent of any such conflict.

No doubt, the defendant in an action of trespass to try title may show an outstanding legal title in another; but, to be available, he must identify the same with the lands in controversy.

As the instruction to find a verdict for the plaintiff in the court below is found to be correct, none of the other questions involved in the case need consideration.

The judgment of the circuit court is affirmed.

THOMSON-HOUSTON ELECTRIC CO. v. WAGNER ELECTRIC MFG.
CO. et al.

(Circuit Court, S. D. New York. October 9, 1902.)

1. PATENTS—INFRINGEMENT—ELECTRIC MOTORS.

The Thomson patent, No. 430,328, for an alternating current motor, in view of the fact that the broad claims of the original application were rejected by the patent office and erased, and that no machine was ever built thereunder, is entitled to only a narrow construction as against an alleged infringer. Claims 1 and 2, as so construed, held not infringed.

In Equity. Suit for infringement of letters patent No. 430,328, for an electric motor, granted to Elihu Thomson June 17, 1890. On final hearing.

J. Edgar Bull and Charles Neave, for complainant.

A. C. Fowler, for defendants.

TOWNSEND, Circuit Judge. Final hearing on bill and answer, raising questions of infringement of the first and second claims of complainant's patent, No. 430,328, granted June 17, 1890, to Elihu Thomson for an alternating current motor. In considering this case the following facts are important: (1) The defendants, by a consent decree in a former suit, had admitted the validity of the patent. (2) This consent decree was signed under the claim that the testimony in the former suit showed that the modified method which defendants purposed to practice would not infringe plaintiff's construction of said patent. (3) All the original claims were rejected on references by the patent office, and were canceled, and the original specification was radically modified. (4) It does not appear that any motor was ever made under the patent in suit. The complainant does not manufacture single-phase motors, except for small fans, and these are not made under the Thomson patent.

The defendants are extensively engaged in the manufacture of single-phase motors. The practical development of such motors was attended with serious difficulties. Certain patents under which defendants manufacture their motors have materially contributed to the success of this type of motors. The single question of infringement depends upon whether the narrow construction contended for by defendants, in view of the history of the application in the patent office and of the prior art, should be adopted.

The patentee says:

"My present invention relates to a method of operating alternating current electric motors in which the rotation is due to the reaction between an alternating current field and an armature, in which currents induced by said field flow in a circuit locally closed on itself."

That is, the patent relates to induction motors, as distinguished from motors in which the current is conveyed to the field and armature by conducting wires.

The patentee then says:

"This class of motors, when running at normal speed, are capable of sustaining their speed of running in synchronism, or nearly synchronism, with the alternations of the feeding wire, but are incapable of starting themselves."

Defendants contend that this statement is incorrect; that some induction motors are capable of self-starting.

The patentee further says:

"My invention consists, broadly, in arranging the motor so that, as a structure, its armature will have different circuit arrangements at the start from those which will exist when it is up to speed or well started in rotation. To accomplish this the motor is started with the armature circuits commuted or changed, so that the armature will receive an initial impulse or impulse of rotation, after which, when the desired speed has been obtained, the connections are so modified, either automatically or at the will of the operator, that the circuit of the motor armature will be locally closed on itself and uncommuted. Briefly, the invention consists in commencing to run the motor with a different circuit arrangement for its armature from that which it will have under its condition of steady normal working or running, such primary condition being one adapted to give a torque, that, being continued for a sufficient time, will bring the motor up to the speed where it may be run with the armature on continually closed circuit."

Defendants claim that the clause, "will receive an initial impulse," taken in connection with the reference to the locally closed circuit after the desired speed is obtained, shows that the initial impulse is to be received by conduction.

The claims in suit are the following:

"(1) The herein-described method of operating an alternating current motor, in which the rotation is produced by the reaction between the field and a locally closed armature circuit carrying currents induced from the field, consisting in organizing or connecting the motor armature circuit so that it may receive an initial impulse of rotation, and, upon the attainment of a predetermined speed, changing or modifying such connections, so as to put the armature coils on locally closed circuit.

"(2) The herein-described method of operating alternating current motors incapable of self-starting, consisting in connecting the armature circuits in a manner different from that which they have during normal work, and in proper way to give the initial torque, and then automatically reorganizing the connections of such armature, so as to put the same on locally closed circuit on the attainment of a predetermined speed."

The respective contentions of the parties are primarily directed to the interpretation of the term "locally closed circuit," as used in the patent. The determination of this question appears to be decisive of the issues involved. The Thomson patent relates to an alternating current inductive motor of the single-phase type; that is, one adapted to receive a single alternating current in a single circuit, and which is incapable of self-starting. Thomson originally purposed to patent broadly any method of starting such motors "under a different set of conditions, or with a different structure, or with a different circuit arrangement from that which it will have under its conditions of steady normal working or running," or by providing commutators only "in carrying out my method at starting." But, upon citation of references, these statements of invention were erased, and the invention claimed was limited to one where, after the initial impulse is received and on the attainment of a predetermined speed, the circuit of the motor armature will be locally closed on itself and uncommuted, or will be put on a "locally closed circuit."

The defendants contend, and have satisfactorily proved, that the term "locally closed circuit," as used by this patentee in prior patents and generally, means a circuit disconnected from the main line. It

refers to a circuit which does not extend from the source of energy, but pertains to the local place, and no other. And defendants claim that the patent in suit is limited to a motor having its coils on a locally closed circuit, after, but not before, the initial impulse of rotation is received. The complainant contends that the term is a relative one, and that when Thomson says in his specification that his invention relates to a method of operating such motors in which currents flow in a circuit locally closed, and says, "This class of motors * * * are incapable of self-starting," he (Thomson) "is referring to a locally closed circuit of such a character that it is not suitable for or capable of causing the motor to start"; that is, one "without the brushes and commutators for exercising directive control over the currents." Complainant further says:

"The defendants use the Thomson locally closed circuited condition when their motor is running. The motor would not start if its circuits were in that condition when the armature was at rest. The defendants, for starting purposes only, use another condition of circuits,—not the Thomson locally closed circuit condition; for, if it were that condition, the motor would not start. The defendants, only after their motor has run up to speed, change their circuit connections and put their circuits in that condition which Thomson meant to define, and in view of his specification did define, as the locally closed circuit condition."

Herein, then, lies the difference between the two devices. In order to start the Thomson motor, you open a switch and the current will be conducted into the armature. If you close that switch, the current stops. Defendants' motor starts by induction, and the motor coils are on locally closed circuits at starting, in the sense that the circuit pertains to the armature only. The term "locally closed circuit," used in the patent in suit, interpreted by its use in two former patents to Thomson, and considered in the light of the file wrapper and contents, must be understood in its general and ordinary sense, as contended by defendants. In this sense defendants' coils are locally closed circuits at starting; complainant's, not until after the running condition is reached.

On the former trial complainant's experts admitted that in the Thomson patent the coils were not on a locally closed circuit at starting, but only on the attainment of the required speed. Thereupon defendants purchased the Anthony, Jackson & Ryan patent, No. 389,352, one of the patents under which the alleged infringing device is manufactured, and in which the armature coils are at starting and always on locally closed circuits. They have developed this class of motors, as already stated, and are now met by the contention that this patent in suit, a mere paper patent, by a broad interpretation of its terms, may be so extended as to embrace the defendants' construction. The effect of this interpretation would be to give to complainant the benefit of the broad claims, rejected by the patent office, for which the present claims were substituted. Whether such a confessedly simple step as that taken by Thomson involved invention, or whether its confessed impracticability deprives it of all claim to utility, it is not necessary to determine. The defendants are entitled to the benefit of the rule requiring a narrow construction of such a patent. Upon said construction there is no infringement, and the bill may be dismissed.

WESTON ELECTRICAL INSTRUMENT CO. v. STEVENS et al.

(Circuit Court, S. D. New York. December 8, 1902.)

1. PATENTS—ANTICIPATION.

If the structures described in prior patents do not themselves anticipate that of a later patent, the descriptions of them in the specifications cannot be held to anticipate.

2. SAME—VOLTMETER.

The Weston reissue patent, No. 11,250 (original No. 433,637), for an electrical measuring instrument, is valid as a reissue, and contains a sufficient description to enable a skilled electrician to construct the instrument. The device was not anticipated by anything in the prior art, but was the first practicable and commercially successful instrument for measuring electrical currents, and especially alternating currents, and is an invention of great merit and usefulness in the art; also held infringed.

3. SAME.

The Weston patent, No. 470,340, for an improved movable coil conductor for use in the electrical measuring instrument, described in the patentee's reissue No. 11,250, discloses patentable invention and is valid.

In Equity. Suit for infringement of reissued patent No. 11,250 (original No. 433,637), for an electrical measuring instrument, granted to Edward Weston, June 28, 1892, and of letters patent No. 470-340, granted to the same inventor, March 8, 1892, for an improved coil for such instrument. On final hearing.

William Houston Kenyon and Kenyon & Kenyon, for complainant.
John P. Croasdale and Joseph C. Fraley, for defendants.

COXE, Circuit Judge. This is an equity action for infringement founded upon two letters patent, granted to Edward Weston. The first of these, reissue No. 11,250, is for an electrical measuring instrument. It is dated June 28, 1892, the original being dated August 5, 1890. The application for the original was filed January 18, 1890. The application for the reissue was filed February 5, 1892.

In the specification the inventor says:

"My invention relates to an electrical measuring instrument intended chiefly for use as an electro-dynamometer for the measurement of alternating currents of electricity.

"My invention consists, broadly, in a fixed or stationary coil and a coil oscillating or vibrating on inclosed pivots in the field of force of said stationary coil, said coils being electrically connected. The vibrating coil on the passage of the current through the circuit, including both coils, assumes an angular position, depending upon the difference of potential between the terminals of the circuit. The reversals of the current in both coils occur simultaneously, and hence an index or pointer connected to the movable coil is always deflected in the same direction, thus indicating the extent of said angular movement upon a suitable scale.

"My invention further consists in the construction and arrangement of the instrument, as hereinafter more particularly pointed out."

Again he says:

"In my present device, and so far as I know for the first time in the art, I cause the index of the instrument to move directly to the scale-mark, which is to be read as the indication and there remain, no bringing back to a zero reading being necessary; and also, as I believe for the first time in the art, I have accomplished this in an instrument where the moving body is, as and

for the reasons already pointed out, controlled by two reacting variable fields—namely, the varying field about the moving coil reacting upon the varying field about the fixed coil. I have discovered that I can balance a coil of fine wire thus actuated against an exceedingly delicate coiled spring or springs, so that the said springs will permit the coil, and hence the index moved by said coil, to move at once to a new position dependent upon the difference in potential between the instrument terminals, and the said springs may be constructed as to strength and elasticity and regulated by the means herein described, so that the indications of the instrument on direct reading will be accurate for all positions of the said movable coil.

"The advantage of the use of two coiled springs, from what has been said, will be apparent. They act as conductors for the current into and out of the coil, obviating the necessity of mercury cups or other form of joint which might offer resistance to the current and introduce friction, hence become oxidized or worn, and hence become a source of error in the instrument. So, also, the instrument having two springs takes the best portable form, and may be used in any position, which obviously could not be done if mercury cups were employed."

The patent has 15 claims, all but the last two being involved. The claims contain the usual tautology and it is unnecessary to examine them all. Claims 4, 6 and 10 are selected as embodying all the essential features of the invention and as representative of all the rest. They are as follows:

"(4) In an electrical measuring instrument, a fixed coil, a movable coil in the field of said fixed coil, an index showing the extent of movement of said movable coil, and a spring opposing and counterbalancing the movement of said movable coil and in circuit therewith, the said elements being constructed and arranged so that said index will be moved directly to show the extent of motion of said movable coil and by the counterbalancing effect of said spring be maintained in such position."

"(6) In an electrical measuring instrument, the combination of a movable conductor actuated by the current to be measured in a field of force maintained by the said current, and a means of indicating the extent of movement of said conductor, the said conductor being constructed to offer such electrical resistance and of such light weight and so freely movable as that the error due to the disturbing effect of self-induction of the actuating current in said conductor shall bear an infinitesimal ratio to the actual indication and be practically nil."

"(10) In an electrical measuring instrument, a stationary coil, a coil vibrating or oscillating in the field of force of said stationary coil, and a spring of conducting material opposing the movement of said vibrating coil, the said coils and spring being electrically connected."

The defenses are lack of patentability, noninfringement and invalidity of the reissue, as such, if construed as the defendants insist it should be.

After the informal but instructive interchange of views between counsel and court at the argument, a discussion at all coextensive with briefs is rendered unnecessary.

Many of the perplexities which usually beset patent causes are entirely absent here. We are enabled to start with several fundamental propositions which, if not admitted, cannot be successfully disputed.

First: Mr. Weston was the first to make a successful commercial voltmeter for measuring alternating currents. His voltmeter soon after coming on the market superseded all others and is to-day recognized as the standard instrument for measuring differences of potential in alternating current circuits.

Second: The device of the patent is small, simple, compact, easily operated and requires no preliminary adjustment. It can be operated at any angle by an unskilled workman and will measure direct as well as alternating currents.

Third: Strictly speaking there is no prior art. If the invention be confined to alternating current devices it can be said with confidence that there were no practical commercial instruments prior to Weston's. There were no instruments entitled to be considered as anticipations. There were two or three instruments, which, as scientific possibilities, could, it is true, reach accurate results; but as every day working devices they were of little value. The most satisfactory of these were, perhaps, the "Thomson balance," invented by Lord Kelvin, the Siemens dynamometer and the Cardew hot wire voltmeter.

The "Thomson balance" is a delicately organized structure valuable in the laboratory, but useless for commercial purposes. It must be accurately leveled and mounted on a firm foundation free from vibrations. No one but an expert can operate it and the final result is only reached after comparison with elaborate tables previously compiled.

The Siemens dynamometer is another complicated and sensitive instrument having a fine wire suspension, mercury cup connections, a torsional spring indicator and several of the faults, noted above, as existing in the "Thomson balance." It was not a direct reader, it was not portable and it required careful leveling after being mounted upon a support free from vibrations.

The hot-wire voltmeter is a clumsy instrument, six feet in length, operating upon an entirely different principle from the device of the patent and depending upon the expansion produced by the heat of the current upon a long taut wire conductor. It was defective, inaccurate, liable to get out of repair and has now disappeared from the commercial electrical world.

There were other instruments, but they were no nearer to the invention than those referred to and have since been relegated to the scrap heaps of the art. They have about the same relation to the Weston device that a mediæval cross-bow has to a modern repeating rifle.

Fourth: The invention is not disclosed in any prior patent or publication.

Fifth: Infringement is clear. The defendants have copied the patented instrument even in its minute details. The only difference entitled to notice is the substitution of a V-shaped spring for the upper flat spiral spring of the patent. The two springs accomplish the same result and are unquestionably equivalents.

It appearing, then, that Mr. Weston was the first to construct a commercial instrument to do this exceedingly important work and that the defendants have appropriated that instrument bodily, it may as well be admitted that the court is not disposed to deprive the inventor of the fruits of his genius and perseverance by subjecting the patent to harsh and technical rules of construction. Few patents that come before the courts are entitled to more liberal treatment.

This is a case where, upon the undisputed testimony, the inventor has accomplished something which has been of unquestioned benefit to the electrical world. In an art crowded with indefatigable and brilliant enthusiasts he has made the only successful alternating current voltmeter in use at the present day. He alone has succeeded, even against the ablest competitors which England, France and Germany could produce.

It is probably true that there is not a lawyer in this circuit who, from a reading of the specification alone, could construct the voltmeter of the patent. The specification is not, however, addressed to lawyers, but to electricians who know the science of electricity and its terms of art just as a chemist knows chemistry and as a surgeon knows anatomy. It matters not how many other people fail to comprehend the meaning of the patent so long as electricians know what it means.

The principal accusation against the patent seems to be that the specification fails to give the necessary information to enable one skilled in the art to practice the invention. It is argued that the prior publications supply this information; if, however, the court should be of the opinion that they do not, then the patent must be held invalid, because it fails, in like manner, to give the necessary details. In other words, the argument seems to be this: Conceding that Weston has made a valuable voltmeter he has failed to describe an invention; the information necessary to construct an operative instrument is either found in the prior publications or it is not; if so found, the patent is anticipated; if not so found the patent fails to supply the information. The defendants' chief reliance is upon the United States patent, granted to Jules Cauderay, of Paris, November 1, 1887, for an electric dynamometer. This instrument was designed for direct currents only; it was useless for measuring alternating potentials; it had a silk-thread suspension and retained many of the faults of the older instruments, which made its success, as a practical device, impossible. There is no proof that the instrument went into use and, if the complainant's experts are correct, it was incapable of accomplishing the results of the Weston structure. Prof. Anthony says:

"As an example of instruments depending upon magnetic forces which totally fail to solve the problem in consequence of the great self-induction as well as for many other reasons, I would refer to the instrument described in the U. S. patent to Cauderay, No. 372,358, and the English patent to the same inventor, No. 225 of 1887. In the instrument described in these two patents there is a moving coil consisting of many turns of fine wire wound upon a spool, the whole being of considerable weight. The coil is said to have a resistance of about one thousand ohms, and this is the only resistance in the circuit. The self-induction of such a coil would be so great as to render it absolutely unfit for an instrument to serve the purpose for which the instrument described in the patents in suit was designed."

The articles in *La Lumiere Electrique* throw little light upon the controversy; they relate to instruments intended to accomplish different results and operating on different principles.

This array of awkward and impracticable structures emphasizes the importance of the improvement made by Weston. It is not neces-

sary to follow the defendants' argument designed to show that the claims can be read on the articles in *La Lumiere Electrique* and the description of the Cauderay patent. None of the structures there described was capable of doing the work of Weston's instrument. A description of a failure stands in no more favorable attitude than the failure itself. If the structures described would not anticipate or limit the scope of the patent a description of them cannot be tortured into an anticipation.

It seems unnecessary to point out that a claim for a combination is not invalidated by the fact that all the separate elements are old. It is necessary to show that the combination is old and this is not shown by reconstructing the claim to fit the exigencies of the litigation from a confused mass of prior literature. When the claims of the patent are limited, as of course they must be, to the mechanism described and shown for the accomplishment of a clearly indicated result, it is thought that nothing in the prior publications destroys the claims either by anticipation or fatal limitation. It is possible that the specification might have been more explicit upon the subject of self-induction but it is thought that enough is found in the description, drawings and claims to enable a skilled electrician to construct the instrument. *Westinghouse Electric & Mfg. Co. v. Saranac Lake Electric Light Co.*, 51 C. C. A. 514, 113 Fed. 884, 887.

The patent is not invalid as a reissue. The public acquired no rights between the original and the date of the application for the reissue. The object of the reissue was not to sweep within the net of the patent instruments which had made their appearance during the interval and which did not infringe the original, but it was to define more clearly the purpose of the invention and the principle upon which it operates. That an inventor may do this, when he interferes with no one's just rights, is not open to controversy. *Hobbs v. Beach*, 180 U. S. 383, 394, 21 Sup. Ct. 409, 45 L. Ed. 586; *Adee v. Peck* (C. C.) 42 Fed. 497.

It is unnecessary to enter upon a microscopic examination of the claims upon the question of infringement, for the reason that if the claims cover Weston's instrument, and it is thought that they do, they cover defendants' instrument also.

Patent No. 470,340, granted March 8, 1892, is for an invention supplemental and subsidiary to the main invention just considered. It is for the improved movable coil of the instrument described in the original and reissued patents. Referring to this instrument the inventor says, in the specification:

"In order to render the apparatus sensitive, it is necessary to make the movable coil as light as possible, both to reduce the inertia of the coil itself and its dead-weight upon the delicate jewel pivots by which it is supported. My present invention has for its object this reduction in weight of the coils; and to this end I make the coil entirely of insulated wire, using no spool or bobbin or frame for its support."

The claims are as follows:

"(1) An insulated coil conductor having numerous turns cemented together to form a compact annular body and provided with pivots, substantially as described.

"(2) An insulated coil conductor having numerous turns cemented together to form a compact annular body and provided on opposite sides with pivots to which the terminals of said coil are respectively connected, substantially as described.

"(3) An insulated coil conductor having numerous turns cemented together to form a compact annular body, in combination with plates B, carrying pivots C, substantially as described."

The defenses are lack of invention and abandonment. Infringement is admitted. The invention is a comparatively trivial one and consists in improvements in the coil conductors of the prior Weston patents. These changes were as follows: The coil is annular, the paper frame of the prior art is discarded and the pivot carrying plates are secured directly to the wire of the coil by "seizings of thin silk." A coil having these features is not found in the prior art. If the patent disclosed nothing more than a reduction of weight and a change in form, patentability would have to be denied. But this is not the case presented by the proof. The improvements, inconsequential as they seem at first, produced important results in reducing the error of self-induction and thus increasing the accuracy of the Weston voltmeter. The coil was not only lighter and more compact, but it produced a result which was distinctly an improvement over that produced by the coils of the prior art.

The complainant is entitled to the usual decree for an injunction and an accounting.

MURJAHN v. HALL.

(Circuit Court, S. D. New York. October 1, 1902.)

1. PATENTS—PROCUREMENT IN FRAUD OF INVENTOR—RIGHT TO EQUITABLE RELIEF.

Complainant alleged in his bill that he was the inventor of a new kind of water paint, which he made and sold in large quantities; that he was induced to disclose the invention to defendant on the promise of the latter that he would keep it secret and would purchase large quantities of the paint from complainant for his own use; that in violation of such agreement and without complainant's knowledge defendant obtained a patent for the paint composition as his own invention, from which he has derived large profits, and which he has used to the injury of complainant's business; and that he threatens to sue complainant's customers for infringement. *Held*, that such bill stated a cause of action against defendant for an accounting and an injunction, and for an adjudication of the invalidity of the patent.

In Equity. On demurrer to bill.

MacFarland; Taylor & Costello and Benno Loewy, for complainant.
Hillary C. Messimer, and John R. Bennett, for defendant.

TOWNSEND, Circuit Judge. The complaint alleges that complainant invented a new water paint, and manufactured and sold large quantities; that defendant claimed to the complainant that he had constant use for such a water paint, and bought and used enough to demonstrate its utility and value; that complainant, at defendant's request, disclosed to defendant the ingredients and mode of manufacture of said paint; that defendant, without the knowledge of the com-

plainant, afterwards obtained letters patent No. 567,592 for said paint composition; that defendant, to induce complainant to disclose to him the invention of said paint, represented that complainant should not be deprived of the benefit of the invention, but that defendant would be a large purchaser of the paint, and that he would not disclose the invention to others; that since the issue of said letters patent defendant has made no purchases of said paint from the complainant, and has recently threatened to bring suit against other customers for infringement of letters patent, if they should make, use, or sell such paint without the license of defendant; that the defendant has derived large profits from said letters patent, and has made and sold large quantities of said paint, and sold licenses under said letters patent,— and prays for a discovery, and that the defendant be decreed to be a trustee for the complainant of said letters patent, and to transfer the legal title thereof to the complainant, and to account for and pay over to complainant all consideration received from the sale of licenses and of the paint. Defendant demurred, and, after the argument and filing of briefs, complainant filed a further brief, in which he insists that, if he is not entitled to the relief prayed for, he is entitled to relief under the general prayer, and applies for leave to amend by adding four more prayers for specific relief, namely:

“(6) That defendant be decreed to account for and pay over to your orator all moneys and valuable considerations received by said defendant from the use by him of said invention, or from the sale by him of specimens of paint embodying the said invention, disclosed to him by your orator, together, also, with all moneys and valuable considerations received by said defendant from sales of licenses or permissions to others to make, use, or sell the same under said letters patent so fraudulently obtained by him. (7) That defendant be enjoined pendente lite from granting territorial or other rights, exclusive or nonexclusive, thereunder, to others, or otherwise employing the same to the prejudice of your orator’s interests in the said invention, and that on the final hearing of this cause said defendant be so enjoined during the remainder of the term of said letters patent. (8) That the defendant be enjoined, restrained, and forbidden from representing himself as being the first or original inventor of the invention hereinbefore and in United States letters patent No. 567,592, dated September 15, 1896, described, and that he be enjoined, restrained, and forbidden from practicing said invention, or granting licenses authorizing others to practice said invention, and from making, vending, or selling, or authorizing others to make, vend, or sell, the same, and from interfering with the practicing of said invention, and the manufacture and sale of said invention, by this complainant, his customers, or licensees. (9) That it be adjudged and decreed that William A. Hall, the defendant herein, is not the first and original inventor of the invention described in United States letters patent No. 567,592, dated September 15, 1896, but that Edward Murjahn is such first and original inventor, and that said letters patent were obtained by fraud practiced by the defendant, William A. Hall, upon the United States patent office and upon the commissioner of patents of the United States, and are absolutely null, void, and of no effect, and that he be perpetually, and pending the final determination of this suit, enjoined, restrained, and forbidden from claiming any right, title, or interest in or to the invention described in said letters patent, or under said letters patent.”

The defendant relies upon *Kennedy v. Hazelton*, 126 U. S. 667, 9 Sup. Ct. 202, 32 L. Ed. 576. The facts in that case are as follows:

“The defendant agreed in writing to assign to the plaintiff any patents that he might obtain for improvements in steam boilers. He did invent

such an improvement, and, with intent to evade his agreement and to defraud the plaintiff, procured a patent for this invention to be obtained upon the application under oath of a third person as the inventor, and to be issued to him as the assignee of that person, and has made profits by manufacturing and selling boilers embodying the improvement so patented. The plaintiff seeks by bill in equity to compel the defendant to assign the patent to him, and to account for the profits received under it."

The court held:

"As the patent, upon the plaintiff's own showing, conferred no title or right upon the defendant, a court of equity will not order him to assign it to the plaintiff, not only because that would be to decree a conveyance of property in which the defendant has, and can confer, no title, but also because its only possible value or use to the plaintiff would be to enable him to impose upon the public by asserting rights under a void patent."

The complainant in *Kennedy v. Hazelton* did not claim to have made the invention in question. Upon the facts submitted on demurrer in the case at bar, complainant had made an invention which he might legally keep secret, and thus secure the benefits to himself. Defendant obtained its disclosure by the representation that such disclosure would not deprive the complainant of the benefit of the invention, and that defendant would not disclose it to others, and would be a large purchaser of the paint; and, having learned it, he proceeded to use it to complainant's disadvantage and make large profits thereby. Upon those facts complainant should be entitled to an accounting and an injunction.

Defendant insists that the validity of the patent can be determined in only three ways; i. e.: (1) An infringement suit, in which the validity of the patent is a defense; (2) a suit between rival patents under section 4918 of the Revised Statutes [U. S. Comp. St. 1901, p. 3394]; and (3) a suit by the government, brought to annul the patent on the ground that it was procured by fraud. No suggestion of any such rule is made a ground of decision in *Kennedy v. Hazelton*, supra, and the case of *Ambler v. Whipple*, 20 Wall. 546, 22 L. Ed. 403, in so far as it is not overruled in *Kennedy v. Hazelton*, seems to support defendant's position. No authority is cited by either party on this point.

The amendment is allowed, and the demurrer is overruled, on the ground that the allegations are sufficient to justify the sixth, seventh, eighth, and ninth prayers for relief. The question of injunction pendente lite will not be decided upon demurrer. No costs to either party.

HURLBUT v. UNITED STATES MAILING TUBE CO.

(Circuit Court, S. D. New York. October 28, 1902.)

1. PATENTS—INFRINGEMENT—PAIER TUBE.

The Hurlbut patent, No. 441,846, for a paper tube, discloses patentable novelty, and is valid, but is limited to a construction in which the cylindrical core has longitudinal seams, and is not infringed by a tube made according to the Denney patent, No. 444,233, in which the core consists of a spirally wound strip.

In Equity. Suit for infringement of letters patent No. 441,846, for a paper tube, granted to Daniel N. Hurlbut December 2, 1890. On final hearing.

Kneeland, La Fetra & Glaze, for complainant.
W. C. Hauff, for defendant.

TOWNSEND, Circuit Judge. Bill for infringement of patent No. 441,846, granted to complainant December 2, 1890, for paper tubes. Defendant contends that the patent is invalid, and denies infringement. The patent in suit covers a simple construction, only slightly differentiated from those used in the general field of the art of tube construction. The argument in its support rests upon the alleged functional results of the special construction of the inner core, with such abutting or overlapping edges as afford substantial resistance to lateral pressure. That the patented tube was intended to discharge such function is evident from the specification; that it accomplishes the result sought, when constructed, as shown in the drawings, with the edges of the core parallel to the axis of the tube, is admitted; and the prior art fails to show any tube so nearly like this construction, as thus limited, to rebut the presumption of novelty arising from the grant of the patent. The defendant does not use such an inner core, but constructs its tubes in accordance with the specifications of a later patent, No. 444,233, granted to Harmer Denney, wherein the patentee, criticising prior paper tubes having longitudinal seams as being always weakest along said longitudinal seam, differentiates his construction as follows:

"By making the core of a spirally-wound strip, the cross-section of all parts of the core will be a perfect and true circle, and each part of said core will be able to resist pressure equally and uniformly. By making the core with a long spiral,—that is, a spiral of great pitch,—the strength and rigidity of the tube are increased, as the long spiral presents greater resistance against bending or shearing strains."

Inasmuch as the complainant patentee nowhere limits himself in specification or claims to such a longitudinal seam, he contends that his invention should be construed to cover any form of inner core, whether a long spiral or longitudinal, which performs the strengthening function of his core, and that Denney's statement, above quoted, shows that he has appropriated such function, and therefore has infringed. This issue requires an examination of the prior art. The commonplace expedient for strengthening both rigid and pliable materials by rolling them in tubular shape, and confining them by means of an outer binding, has been developed in a variety of ways, and applied to all manner of structures from paper rolls to rubber hose and metal pipes. Thus Pearson, in 1854, patented a gun barrel composed of two strips of metal, the one wound spirally upon the other, and with abutting edges. And Stow, in his patent No. 110,399 of 1870, shows a pipe consisting of an inner core having abutting or overlapping edges running spirally, and spirally wrapped. In the patent in suit the patentee says, "I do not limit myself to a paper tubing, as metal might be used," etc. But the patent is especially designed to cover paper tubes, and the patent chiefly relied on by defendants to defeat the patent in suit is No. 374,133, granted in 1887

to C. S. Taintor for a paper cylinder for graphophonic records. This patent shows one tube consisting of a strip of paper wound in a spiral of very slow pitch, covered by another tube similarly constructed. The edges of each of the strips abut throughout, and may be wound either in opposite directions or in the same direction so as to break joints with each other. The object and effect of such windings is to strengthen the tube. Complainant contends that, "owing to the slow pitch of the inner layer of the Taintor tube, it results that the said inner layer does not perform in any wise the function of the core of the Hurlbut patent in suit." Defendant contends that it is "a direct and complete anticipation of the broad construction which has been placed upon the Hurlbut patent in suit." I am inclined to agree with both of these conclusions. The slow pitch of Taintor does not make as strong a tube as the greater pitch of Denney. But given the double-core paper construction with a pitch, the length of pitch was a mere matter of degree, a mere mechanical development of the original idea to meet the greater strength required for tubes to be used for electrical conduits or for mailing purposes. The contention of noninfringement is sustained.

Let the bill be dismissed.

HUTTER v. DE Q. BOTTLE STOPPER CO. et al.

(Circuit Court, S. D. New York. October 7, 1902.)

1. PATENTS—SUIT FOR INFRINGEMENT—EVIDENCE.

Where a patent sued on is intelligible without evidence, but defendant introduces expert testimony, it is proper for complainant to introduce the same kind of testimony in rebuttal.

2. SAME.

Where defendant has not denied under oath the making and selling of the articles offered in evidence by complainant to prove infringement, evidence which establishes a strong probability of such fact is sufficient to make a prima facie case.

3. SAME—BOTTLE STOPPERS.

The Hutter patent, No. 491,113, for a bottle stopper, held valid and infringed.

4. SAME—DESIGN FOR BOTTLE STOPPERS.

The Hutter design patent, No. 25,435, for a design for a bottle stopper, held valid and infringed.

In Equity.

Briesen & Knauth, for complainant.

Henry Schmitt, for defendants.

TOWNSEND, Circuit Judge. Suit for infringement of patent No. 491,113, granted February 7, 1893, to Karl Hutter, for a bottle stopper, and patent No. 25,435, granted April 28, 1896, to Karl Hutter, for a design for a bottle stopper. All of the issues in this case, so far as they concern the validity of the patents, have been considered, upon practically the same evidence as to the same infringing devices, and with the same expert testimony, by the circuit court in the Third circuit, in the case of Hutter v. Broome, 114 Fed. 655.

After a careful examination of the patents, defendants' evidence, and the opinion of Judge Gray, which states the situation of the matters in issue fully and clearly, this court feels constrained to adopt his conclusions.

Defendants claim that certain expert testimony produced on rebuttal should have been taken in chief, and is not proper rebuttal testimony. The patent was intelligible without the aid of evidence. But inasmuch as defendants saw fit to introduce expert testimony, I think complainant's further evidence was proper in rebuttal, and that, in the circumstances, defendants' claim that it was not taken in time should not prevail.

The defense now seriously urged is that there is no sufficient evidence that the defendants made or sold the articles offered in evidence by complainant to prove infringement. Defendants have offered no denial that such is the fact, but they insist that the evidence offered by complainant was not sufficient to put them upon their proofs. This is a case where the evidence of the facts, if they exist, is peculiarly within the knowledge of the defendants, and where it would have been a very slight matter for defendants to have proved noninfringement, if it really existed. The evidence offered by complainant, while it might not be sufficient to overcome a denial under oath, is sufficient, in the absence of any such denial, to establish a very strong probability of the existence of the facts claimed, and to make a prima facie case. *Municipal Signal Co. v. National Electrical Mfg. Co.* (C. C.) 97 Fed. 810, 813; *Id.*, 46 C. C. A. 270, 107 Fed. 284.

Let a decree be entered for an injunction and an accounting.

BARNSDALL v. BOLEY et al.

(Circuit Court, N. D. West Virginia. December 3, 1902.)

1. OIL LEASE—UNAUTHORIZED ALTERATION—WAIVER OF OBJECTION.

After the execution of an oil lease for the term of five years, covering a number of tracts of land, the lessee discovered that certain heirs owned an interest in one of the tracts, and secured their signatures to the lease by making an interlineation therein giving them the right to receive their share of the royalty. The original lessor had no knowledge of the interlineation at the time, but was shortly thereafter advised of it, and made no objection, but throughout the term insisted on the performance of the contract by the lessee, and accepted the royalties thereunder. *Held*, that he thereby waived the right to insist on the invalidity of the lease because of the alteration.

2. SAME—PARTIES—PERSONS NOT NAMED IN BODY OF INSTRUMENT.

Under the law of West Virginia a person whose name is not mentioned in the body of a lease is not a party thereto, nor bound thereby as a grantor, although he signs and acknowledges it as his deed.

3. SAME—POWER TO GRANT—TENANT BY THE CURTESY.

A tenant by the curtesy cannot convey the right to a lessee to extract oil from the land, and a lease executed by him purporting to convey such right is void.

4. SAME—RIGHT OF LESSEE TO EXTENSION OF TERM—FAILURE TO DEVELOP PROPERTY.

Defendant executed to complainant's assignor an oil and gas lease on royalty covering 74 acres of land, which was to run for the term of five

¶ 1. See *Alteration of Instruments*, vol. 2, Cent. Dig. §§ 94, 105.

years, and as much longer "as oil or gas was found in paying quantities." It required the lessee to complete a well thereon within three months, which he did, but drilled no other wells, and made no serious effort to do so during the five years, although he was repeatedly requested to do so by the lessor. The well drilled was a small producer, and was pumped at intervals, only, during the last year or two of the term, not producing enough to pay the expense of pumping. *Held*, that the lessee did not comply with the implied condition of the lease, which required him to develop the property in good faith; and that a court of equity would not sustain and enforce the lease in his behalf after the expiration of the five years, as against the lessor and others to whom he had leased after that time, and who had rendered the property productive.

In Equity. Suit by a lessee for the enforcement of an oil lease.

Van Winkle & Ambler, for plaintiff.

A. D. Follett and Clyde B. Johnson, for defendants.

JACKSON, District Judge. The question in controversy in this case is the validity of a lease executed by John Boley to S. T. Mallory on the 11th day of January, 1895. By the terms and provisions of that lease 100 acres of land, more or less, was granted by the lessor to the lessee for a period of five years, and as much longer as "oil or gas was found in paying quantities," paying to the lessor the one-eighth part of the oil as royalty. It appears from the evidence that this lease embraced four tracts of land,—one tract of 45 acres, one tract of 25 acres, one tract of 4 acres, all of which belonged to John Boley, and one tract said to contain 40 acres, but turned out to contain 68 acres, belonging to the heirs of Caroline Boley. John Boley, in making this lease, consolidated these tracts, and gave a lease as if it were but one tract. Shortly after the lease was executed, it was discovered that John Boley was merely a tenant by curtesy, his wife, Caroline Boley, having died some time previously, which left him no estate in the 68 acres except a life estate as tenant by curtesy. The evidence discloses the fact that shortly after this discovery Mallory saw the heirs of Caroline Boley, and secured from them their signatures to the lease, but before securing their signatures he was compelled to insert a provision in the lease that the heirs of Caroline Boley were to receive their share of the royalty from the 40-acre tract. This interlineation or insertion was made in the absence of John Boley, and he was in no wise a party to it, though it is very evident from the evidence that he was informed of this change in the lease, but he never raised any question about it during the whole period of five years the life of the lease. Some time in February, 1895, Mallory commenced drilling a well on the four-acre tract, and completed and drilled it on the 4th day of March, 1895. The well was then pumped, and after a short time it was shut down. This well was pumped at intervals from time to time during the lifetime of the lease, but there never was any continuous pumping of the well, for the reason, as is apparent from the evidence, that the production of the well was so small that it did not justify a continuous pumping, and was, therefore, only pumped by "heads." The evidence shows that but one well was drilled upon the leased property, although the lessor repeatedly during the lifetime of the lease requested Mr. Reynolds, the agent of the lessee to put down other wells

and develop the property; and to notify Mr. Barnsdall, to whom the lease had been assigned, of his various and repeated requests. The evidence discloses that there was never any effort upon the part of Barnsdall or his agent to further develop the property, although his agent repeatedly promised to drill wells upon the leased premises, unless the effort of Mr. Reynolds to "move a rig to the John Boley farm from the Jobe Smith place in March, 1899, for drilling for oil," is to be considered an act upon the part of the lessee tending in good faith to comply with the terms and provisions of the lease. The witness Owen Boley says he was approached about that time by Reynolds, the agent of Barnsdall, and that he agreed to haul that rig, as the evidence discloses, for \$25, and that John Boley, the lessor, in the lease objected to him crossing his land to place the rig on the leased premises, and the effort to move the rig seems to have ended there. There is no evidence tending to show that Reynolds, as the agent of Barnsdall, ever made any other effort to do any drilling on the leased premises. This objection of John Boley to Reynolds crossing his land for the purpose of carrying a rig is set up as a reason why the lessee could not comply with the terms of the lease. On the 14th day of April, 1900, John Boley executed a lease for 45 acres of land, a part of the premises leased to Mallory on the 11th day of January, 1895, to Watt and others. On the 12th day of May, 1900, John Boley leased the 25-acre tract of land to A. H. Highby another portion of the leased premises, which was leased to Mallory by John Boley on the 11th day of January, 1895. On the 7th day of April, 1899, Barnsdall served a written notice on C. J. Watt and others that he claimed the property that had been leased by John Boley to S. T. Mallory on the 11th day of January, 1895, and was afterwards assigned by Mallory to him, which notice appears to have been served before John Boley leased to Watt and others. On the 5th day of September, 1900, Barnsdall filed his bill in equity in this court, and obtained an order from the court restraining all the defendants in the bill from interfering with his rights under the lease of January 11, 1895, or from drilling or operating upon any part of the said leased premises, and from removing the oil therefrom. It is clearly the object and purpose of this bill to insist upon the terms and provisions of the lease between the contracting parties of the 11th day of January, 1895. To this bill, answers of various defendants have been filed, denying the validity of the lease, and insisting that whatever rights the lessee had under the lease have been terminated, not only by the expiration of the term for which the lease was given, but by reason of the fact that the lessee had utterly failed and neglected to prosecute in good faith the development for oil under the leased premises. The lease was executed on the 11th day of January, 1895, and was to run for a period of five years, and as much longer as oil or gas was found in paying quantities. The evidence discloses that there never was but one well drilled upon the property, and that well is what is termed a "small producer," and during the period of over five years—the lifetime of the lease—it only produced about 800 barrels.

The first question to be considered is the question raised by the defendants as to the validity of the lease of January 11, 1895, who insist that the interlining and inserting in the lease the words "forty acres, more or less, of Caroline Boley, her heirs, are to receive their share of the royalty, that is included in the lease," after the lease was executed and delivered by John Boley to S. T. Mallory, was such an alteration of the contractual relations between the parties as would render it invalid, and not binding upon the defendants. It is a general rule that, where a written instrument shows an alteration by interlineation or erasure upon its face, the presumption, in the absence of evidence, is that it was made after the execution of it, and the burden is upon the party claiming under the instrument to explain the alteration. 2 Am. & Eng. Enc. Law (2d Ed.) p. 276, § 5, and the authorities there cited. Upon the evidence in this case there can be no question that the alteration was made by the parties without fraudulent intent, after the execution of the contract between John Boley and S. T. Mallory on January 11, 1895, and in this instance would not be binding on John Boley, who was the only lessor in the contract prior to the execution of the lease by the heirs of Caroline Boley, unless by unequivocal acts he waived any advantage that he could take of such an alteration, and recognized the binding effect of the lease between himself and the lessee. It is clearly apparent from the evidence that he knew of the alteration in this lease very shortly after the alteration was made; that he made no objection to it; that he never gave any notice to the lessee that it was invalid, or that he would not be bound by it, but, on the contrary, he recognized the legal and binding effect of the lease by receiving and collecting the one-eighth royalty provided for by the terms of the lease as a rental, which was to be paid to him. This recognition upon his part continued during the lifetime of the lease, during which time he never raised any objection in regard to its alteration. Can it be said, and ought a court to hold, that, where a party has executed a paper of this character, and the alteration made in it after its execution has been brought to his attention, and he makes no objection to it, but acquiesces in the alteration, and enforces the terms and conditions of his contract in other respects, that, after the life of the contract had expired, he can avail himself of a defense of this character? I think not. His acquiescence in the lease and collection of the royalty during the lifetime of the lease must be held to be a waiver upon his part of any objection that he might have or could have taken in regard to the alteration, and for this reason he is estopped from setting up such a defense.

Another objection to the validity of the lease raised by the defendants is that the heirs of Caroline Boley are not named as grantors in the body of the lease, and that for that reason the lease is invalid, and not binding upon them. In the courts of this country there is some contrariety of decisions upon this legal question, some courts holding that the name of the grantor need not appear in the body of the deed if the identity of the grantor can be ascertained with reasonable certainty. I am relieved, however, from discussing this question, for I think it is well settled by the authorities both in Vir-

ginia and West Virginia that, where the name of a grantor does not appear in the body of a deed, and where there is no mention of the grantor in the body of the deed as a party to it, although he may have signed and acknowledged it as his deed, it does not convey anything. Judge Snyder, in the case of *Adams v. Medsker* said: "No one who is not a party to the deed can be bound by it or by its covenants; and no one can be a party who is not mentioned or referred to therein." *Adams v. Medsker*, 25 W. Va. 127; *Bell v. Allen's Adm'r*, 3 Munf. 118; *Bartley v. Yates*, 2 Hen. & M. 398; *Beale v. Wilson*, 4 Munf. 380. In this case the evidence clearly shows that the lease was signed by the heirs of Caroline Boley, but the acknowledgment certified to by the justice is disputed by two of the parties who signed the lease. Nowhere does it appear upon the face of this lease that any of the heirs of Caroline Boley were named as grantors in the lease, nor were they ever consulted in regard to the lease at the time it was executed between Boley and Mallory. It is true that they signed it, but, so far as the evidence discloses, nothing has occurred since the execution of the lease to prevent them from setting up this defense. The evidence clearly shows that two of the heirs of Caroline Boley—Levi W. Boley and A. J. Boley—never acknowledged the lease, and the testimony of the justice who took the acknowledgment, in speaking of it, says that he does not recollect that they were ever before him, or that they ever acknowledged it, although he certified to the acknowledgment. His testimony upon this point is very unsatisfactory. Of course, he cannot be heard to deny his official certificate, but other parties interested as these defendants are have a right to show that they never acknowledged the lease, and to contest the correctness of the certificate of the justice to that fact. For this reason we conclude that they are not bound by it. It is apparent that these two heirs of Caroline Boley, who were induced to sign the lease, never acknowledged it, for they did not sign it at the office of the magistrate, nor did they sign it at the same time and place that John Boley signed it, but at different places and upon different occasions. It also appears that two of the heirs John E. Boley and Robert Boley were under age at the time they signed and acknowledged the lease, and it does not appear that they ever ratified it since they became of age, and for this reason they are not bound by the terms and provisions of the lease.

It is not denied that at the time John Boley executed the lease to Mallory he had no title to the land. His only claim to the land was that of possession as a tenant by curtesy, which only gave him a life estate in the realty. While such an estate gave him the right to the full enjoyment of the use of the land during its continuance, it did not permit him to commit any waste which would lessen or diminish the value of the freehold estate. The lease that John Boley entered into with Mallory authorized Mallory to extract and take the petroleum oil from under the land covered by the lease. Being a mere tenant for life, and only entitled to the possession of the property, he had no such legal interest in the estate as authorized him to enter into a contract with any one to explore and drill wells upon

the property for the purpose of extracting and taking from it petroleum oil. This principle has been settled in West Virginia in the cases of *Williamson v. Jones*, 43 W. Va. 562, 27 S. E. 411, 38 L. R. A. 694, 64 Am. St. Rep. 891; *Wilson v. Youst*, 43 W. Va. 826, 28 S. E. 781, 39 L. R. A. 292. In both of these cases it was held that petroleum oil was a part of the realty, and, being part of the realty, a tenant for life had no right to lease the land to any one for the purpose of extracting and taking petroleum oil from under it.

It is apparent from what I have said that the lease of John Boley to S. T. Mallory on the 11th day of January, 1895, so far as the 40 acres, now known as the "sixty-eight acres," is concerned, conferred no right or power upon Mallory or his assignees to drill and extract oil from under that tract of land. It is absolutely void for that purpose. Boley had no title to the realty, and he could not grant and convey a right to another which he did not possess. The heirs of Caroline Boley, being the owners in fee by inheritance, were the only parties who could grant and convey a right to any one to drill and operate for petroleum oil upon the leased premises. As we have seen Levi W. Boley and A. J. Boley never acknowledged the lease, and John E. Boley and Robert Boley were minors, and could not execute a contract that would bind them, and that since they arrived at age they have never ratified their action, we reach the conclusion that these four parties to the lease are not bound by it. The two other parties to the lease Mrs. Lotta B. Adams and Mrs. Nora Sunderman signed the lease, but only Mrs. Adams acknowledged it, and, as they were not grantors in the body of the deed of lease, nor mentioned in it, I am of the opinion that this lease is invalid and void for the purpose of granting to the lessee the right to drill and extract petroleum oil from under that portion of the leased premises embraced in the 40-acre tract.

Having reached the conclusion that the lessee, or his assignees, acquired no rights under the lease of January 11, 1895, so far as it proposes to grant the right to develop the land covered by it for oil on the 40-acre tract of land, I will now consider what are the rights of the lessee as to the 45, 25, and 4 acre tracts, which are covered by the lease as one tract. No question is raised as to John Boley's right to lease these tracts for the purpose set out in the lease, but it is claimed by the defendant John Boley that the rights of the lessee have ceased by the terms of the lease, and that the lessee has no right to maintain this action against him as the owner and lessor of the land. Upon this question the doctrine of estoppel does not arise, as the lease expired by its own limitation. The only question for consideration is, has the lessee the right to hold the leased premises after the expiration of the lease? If, then, the lessee has complied with the terms and provisions of the lease under which he claims the right to operate and develop the tract of land for oil purposes, there could be no question as to his legal rights under the lease; but it is claimed by the lessor that the lessee has failed to comply with the terms of the lease by neglecting to develop, in good faith, the territory embraced and covered by the lease for oil purposes. As we have seen, I have reached the conclusion that John Boley

cannot avoid or excuse himself from complying with the terms of his lease to Mallory, as to the 45, 25, and 4 acre tracts; but, while that is true, it does not excuse the lessee from complying with the terms and conditions of the lease on his part.

The question that presents itself for the further consideration of the court is, has the lessee in good faith complied with the terms and conditions of his lease, and is he entitled to the relief sought for by his bill? On January 11, 1895, S. T. Mallory leased from John Boley 100 acres of land, more or less, "for the purpose and with the exclusive right for operating thereon for oil and gas," together with other rights, which are immaterial to refer to. That lease was for the term and period of five years from its date, and as much longer as oil or gas was found in paying quantities. There was a provision contained in the lease in reference to gas, which is not deemed important to refer to, as the only well drilled is not a gas well. The lease required that a well should be completed upon the premises within three months from its date. Unless completed it should be null and void. There was a well drilled on the lease within the three months, the time provided for in the lease, and was a compliance with that provision of the contract; therefore, no forfeiture could take place. It is contended, however, that the evidence discloses that the lessee did not in good faith proceed to develop and operate the territory embraced in this lease for oil and gas. By the terms of the lease it had five years to run. During the lifetime of the lease there was but one well put down, although the evidence discloses that the lessor, John Boley, often requested and demanded that the lessee should proceed to develop the land covered by the lease for petroleum oil, and, as often as he requested, the agent of the lessee promised to comply with his requests, but, as I have said, there was no effort upon the part of the lessee to comply with the repeated demands of the lessor, unless the futile attempt by Reynolds, as the agent of the lessee, in March, 1899, to have a rig placed upon some portion of the land for the purpose of drilling another well, was an act in good faith upon the part of the lessee as evidence of his intention to comply with the terms and provisions of the lease. It is true that Owen Boley says that John Boley, the lessor, notified him not to cross his land for the purpose of hauling a rig upon the leased premises to drill another well. Owen Boley, who made the contract with Reynolds, says he notified Reynolds of that fact, and Reynolds admits that he did; but it does not appear from the evidence that there was no other way of getting upon the leased premises to continue the operations of drilling another well, nor does it appear that the agent of Barnsdall, or Barnsdall himself, ever made any strenuous effort, either legal or otherwise, after the information that Owen Boley conveyed to Reynolds to go upon the leased premises for the purpose of further development. This information was conveyed to Reynolds in March, 1899, less than a year before the lease, by its own terms, expired, which should have caused the lessee to have taken immediate action to assert his rights, if any he had. There is not even a pretense that such was the fact.

Is a court of equity, disposing of rights between parties, to hold

that an obstruction of that character is a reason why the lessee in this case should be absolved and released from the performance of his duties under the contract? I think not. It was a reason why a greater effort should have been made, if the agent of the lessee intended in good faith to proceed with the further development of the leased premises for oil. There is no evidence in this case that another effort was made before or since that time during the lifetime of the lease, nor, in fact, since its termination. We must hold that this excuse for a failure to prosecute the work in the development of the lease for oil is inadmissible as a defense upon the part of the lessee in neglecting to comply in good faith with its legal requirements. But it is claimed that, inasmuch as the lease provided that the lessee could hold, not only "for the term and period of five years from its date, but as much longer as oil or gas was found in paying quantities thereon," the lease is valid, and binding upon the lessor, John Boley, for the reason that the one well that has been drilled upon the leased premises known as the "four-acre tract" produced oil, and that he had received his royalty from that production. The evidence discloses, as we have said, that it is a small producer; in fact, so small that it did not justify the continuous pumping of the well; and when it was last pumped in 1899, it only yielded about three-fourths of a barrel per day. Reynolds testified in reference to pumping the well, and says "that he hired a pumper there to pump the well along, and furnished the fuel for it." The evidence of six witnesses of great experience in the oil fields has been taken in this case, who have had long experience both in drilling and pumping wells, and they state that a well yielding no more than this well has yielded, as shown by the evidence, could not of itself be a paying well. What is a paying well? Is the cost of drilling a well embracing the machinery purchased for that purpose to be considered as an element to determine whether it is a paying well or not? I think not. It must be a well whose product covers the expenses incident to the pumping of it. If it does not pay a profit over the operating expenses, can it be said that oil is found in paying quantities? I think not. It was expressly held in the case of *Young v. Oil Co.*, 194 Pa. 243, 45 Atl. 121, that where oil has been found, but no longer pays the expenses of production, that it is not producing in paying quantities, and, applying that principle to the terms of this lease, if oil at the date and institution of this suit and for some time previous had not been found in "paying quantities," would it be right and just to prevent the lessor from releasing his land? The answer to that question is obvious. The principle established in that case is that sufficient oil must be found to justify the operator in pumping the well or wells at a small profit over and above the actual expenses.

An exhibit has been filed by the plaintiff in this case, claiming that it is a statement of the Eureka Pipe Line Company of the oil received by that company from Barnsdall and Reynolds, commencing with December 3, 1895, and closing with April 1, 1901, which is a period of nearly six years from the date of the execution of the lease by John Boley to S. T. Mallory. That exhibit shows that during that period 806.61 barrels were produced, which is an aver-

age of 134.43 barrels per year. It does not appear from that exhibit where that oil came from. It only appears that Barnsdall and Reynolds had such an oil account; but, assuming the fact to be true that it came from the Mallory well, which was drilled on the four-acre tract, we find that the well produced during the year 1900 104.95 barrels, or about 12 gallons per day. It does not appear what the price of oil was at that time, nor what the price of oil was at the end of five years, when the lease was, by its own limitation, terminated. The question that presents itself at this point is, if this was a paying well, why was it that the lessee did not proceed to drill other wells, and to further develop the tract? Why would he content himself with a small producer like this, which was merely paying at best a small profit over its expenses during the first years of the lease, when the evidence tends to show that it did not pay any profit at the end of the lease? What the motive and purpose for such action was, I am unable to determine, unless he was satisfied that the territory was what is termed in the oil parlance "dry territory." It is true that he pumped this well at various times, pumping off what might be called the "heads," but it is equally true that at various times he removed his machinery from the leased territory, and for the time seemed to have abandoned it. If, in fact, it had been a paying well, why did he remove his machinery, and cease to pump it? The well did not flow. It could not be pumped continuously, and when pumped in the last three or four years it was only pumped by "heads," and finally it did not yield more than 12 gallons per day, as the evidence discloses. Mr. A. J. Boley proves that the well was pumped occasionally from time to time until August or September, 1896, and that after that "the well stood for a long time, and was shut down," and from that time to the time he gave his deposition in this case—which seems to have been taken in April, 1900—it had not been pumped on an average of once a month. It is apparent to my mind that the lessee pursued this course in regard to this well with the hope that such action would preserve his rights under the lease. Can it be said that, where a man "sleeps upon his rights," as the lessee has done in this case, such action upon his part is in good faith? Was it good faith to hold the lease for a period of five years, and only drill but one well on the leased premises, and that well a failure, as the evidence shows? I think not. Is it evidence of good faith to pump a well at a loss to the lessee for two or three years before the expiration of the lease? I think not. I am aware that decisions of some courts hold that the lessee is to determine whether the lease is a paying one or not, but the lessee must act in good faith. The lessee should not be permitted in a court of equity to insist upon retaining a lease after its term had expired without having made any effort upon his part in good faith to develop the property. Certainly he ought not to be permitted to hold the lease merely to prevent others from drilling upon the territory covered by the lease, which would operate a great injustice to the lessor. The lessor when he entered into this lease with S. T. Mallory had a right under its terms to expect that the property would be developed; and he had a right to insist upon it, as he did from time to time, that the property should be developed; but, notwithstanding

his repeated demands to have the property developed, the lessee disregarded, not only his wishes, but his interests in the property. Contracts must be mutual. The rights of the lessor must be protected just as fully as the rights of the lessee. When the lessee, as in this case, neglects and refuses to comply with the contract in good faith, we must hold that the provision in the contract, which says "that the lessee is to have the leased property, not only for a period of five years, but as much longer as oil or gas is found in paying quantities thereon," is a provision that is to be construed with reference to the rights of the lessor as well as the rights of the lessee. The lessee will not be permitted to retain possession and control of the leased premises merely because of the insertion of the words in the lease "as much longer as oil or gas is found in paying quantities" unless oil is actually found in such a quantity as to warrant the lessee in pumping the well. In determining this question he must exercise sound discretion, such as prudent business men would ordinarily exercise in the management of their business; but this discretion, when exercised by him, must be a discretion in good faith, not an arbitrary one upon his part. It must be a discretion based upon the product of the well, which alone can demonstrate whether it is a paying well. Is the lessor to be deprived of his rights in having his property developed when wells may be and are sunk all around his property, because the lessee may claim the right to develop the property when it suits him? Having drilled but one well on the leased premises, and because the lease only provided for one well to be drilled upon it, and failing to further develop the property, it would seem to be the duty of a court of equity to interfere, and redress the rights of a lessor under such circumstances. If the lessee had within the period of five years drilled other wells on the leased premises, and showed a disposition to develop it, a court of equity, under such circumstances, would be justified in holding that such action was a compliance with the terms of the lease. He who asks equity must do equity. The plaintiff in this case has asked for relief. What relief is he entitled to? Can a court of equity grant him any relief if it reaches the conclusion that he has frittered away his rights, and never discovered that there were any obligations upon his part under the lease to develop the property for oil during the term of five years the life of the lease? I think not.

It is said by the court in the case of *Harness v. Oil Co.*, 49 W. Va. 232, 38 S. E. 662, "that the production in paying quantities of either oil or gas, and the payment or delivery of the royalty as provided for in the contract, will perpetuate the lease during the time of production." There can be no question about that proposition of law that the lease will be perpetuated during the production in paying quantities of either oil or gas. But such is not this case. This is a case that more properly falls within the ruling as stated in *Steelsmith v. Gartlan*, 45 W. Va. 27, 29 S. E. 978, 44 L. R. A. 107, which holds that a completion of a nonproductive well, though at a great expense, vests no title in the lessee. This well, as the evidence discloses, seems to be a nonproductive well. Although the drilling of the well has cost the lessee possibly a large sum of money,

yet that fact alone does not condone his neglect to operate and develop this lease, nor does it release him from his obligations in good faith to do so. I see no reason why a lessee should hold on to the property of the lessor during the lifetime of the lease, claiming the right to operate it at his pleasure, and thereby defeat the rights of the lessor to relet the property to parties who would develop and operate it. Such is the history of this case. The lessor quietly awaited the expiration of the lease. He repeatedly asked and demanded of the lessee that the leased premises should be developed, to which repeated requests and demands there came nothing but promises, which were never fulfilled. The lessor then determined to relet the 45-acre tract to Watt and others, and the 25-acre tract to A. H. Highby. The lease to Watt and others was made in April, 1900, and the lease to A. H. Highby in May, 1900. The lease to S. T. Mallory expired on the 11th day of January, 1900. This bill was filed on the 5th day of September, 1900, about four months after these leases were made to Watt and others and A. H. Highby, and not until after it was discovered that the drilling under these leases produced paying wells. Can it be said that a court of equity will permit a lessee to wait until after the expiration of his leased term with a nonproductive well, and drill but one nonproductive well during the lifetime of the lease to enforce that lease, and hold it valid against the lessor by reason of the fact that he alone is to determine whether or not this nonproductive well is a well in paying quantities? I think not. I think that equity will require good faith upon the part of the lessee in the performance and discharge of his obligations under his contract. What that good faith is must be determined by all the surrounding circumstances.

The lessor, when he made this lease to Mallory, contemplated the development of the leased premises, and had a right to expect, by the very terms of the lease, that the property would be developed in good faith. This was the main consideration for the execution of the lease, and, if the lessee failed to fully develop the property during the lifetime of the lease, the lessor had a right to conclude, after the lease had expired by its own limitation, that the lessee had abandoned it, and lost his rights under it, and would, therefore, be justified in re-leasing the property. It was held in the case of *Foster v. Gas Co.*, 32 C. C. A. 560, 90 Fed. 178, that:

"The agreement to dig one well within one year secures the prompt beginning of these operations. The completion of the well saves the penalty. It does not amount to a fulfillment of the covenants. The consideration, therefore, for this lease was the prospective rents and royalties the lessor would enjoy if the lessee, by diligent search, could find oil and gas in paying quantities. If the lease failed to bind the lessee to diligent search for oil or gas, it was without consideration, binding on neither party, and voidable at the pleasure of either."

This position is sustained by the following line of cases, to wit, *Cowan v. Iron Co.*, 83 Va. 547, 3 S. E. 120; *Petroleum Co. v. Coal, Coke & Mfg. Co.*, 89 Tenn. 381, 18 S. W. 65; *Ray v. Gas Co.*, 138 Pa. 576, 20 Atl. 1065, 12 L. R. A. 290, 21 Am. St. Rep. 922. In the last-quoted case the supreme court of Pennsylvania says:

"The clear purpose of the lessor was to have his lands operated for oil and gas, and the condition was inserted for his benefit. Whilst the obligation on

part of the lessee to operate is not expressed in so many words, it arises by necessary implication. The lease was for the expressed purpose of drilling and boring for oil or gas; the lessor, in a certain event, to receive a share of the production as a royalty or rent, and, in another event, to be paid \$500 per annum for each gas well the product of which was conducted from the land for consumption."

I am inclined to think, under the circumstances of this case, that the lessee, or his assignees, has neglected to comply with every provision of the contract except that provision which requires the sinking of one well, and the lessee, or his assignees, are justly chargeable with laches for having slept so long on their rights by their failure and neglect to comply with the terms of the lease.

For the reasons assigned, I reach the conclusion that neither the lessee, S. T. Mallory, nor his assignees, who claim under him, are entitled to enforce the terms and provisions of the lease of January 11, 1895, against the grantor, John Boley, or those claiming by subsequent leases under him. But, inasmuch as the lessor, John Boley, has waived in his pleadings his right to enforce a forfeiture of the rights of the lessee as to the four acres, a decree will be drawn giving the lessee the right to elect whether he will further develop the four acres, or abandon it, with leave to remove all his machinery, tackle, and appliances ordinarily used in drilling an oil well.

CALIVADA COLONIZATION CO. v. HAYS.

(Circuit Court, W. D. Pennsylvania. December 3, 1902.)

No. 6.

1. EQUITY PLEADING—ANSWER AS EVIDENCE.

Unless answer under oath is expressly waived in the bill, such answer, if responsive, is evidence on behalf of the defendant, and to overcome it complainant must have at least one sustaining witness and corroborative circumstances.

2. EVIDENCE—TESTIMONY OF PARTY CALLED BY ADVERSARY.

The Pennsylvania act, permitting a party to be called and examined "as on cross-examination," has no application in a suit in equity in a federal court, and a party so called and examined therein becomes a witness for the party calling him, and his testimony is to be given weight accordingly.

3. CORPORATIONS—VALIDITY OF STOCK—ISSUANCE IN PAYMENT FOR SERVICES.

Complainant corporation by resolution of its board of directors, passed shortly after its organization, issued over one-half of its stock to defendant, who was its president, in consideration of services rendered by him in obtaining contracts and options on property, all of which were turned over to the corporation, and through them the company obtained all lands which were the basis of its operations. The transaction was fully shown on the books of the company, and was approved by all its then stockholders. There was also an understanding that defendant should use a portion of such stock for the purpose of interesting other persons in the company, which he did, retaining for himself but a comparatively small portion. Held that, in the absence of proof of an actual fraudulent intention, such stock was not illegal, and subject to cancellation at the suit of persons who subsequently became stockholders with full opportunity to know the facts, either under the general rules of law or under the laws of Colorado, where the corporation was organized,

which permit the issuance of stock for labor done or services performed or property actually received.

4. EQUITY—LACHES—PLEADING.

Laches need not be pleaded as a defense, but it is sufficient to defeat relief in a court of equity if it appears from the evidence.

5. CORPORATIONS—SUIT TO CANCEL STOCK—LACHES.

A suit by a corporation or stockholders for the cancellation of stock of the corporation on the ground that its issuance was unauthorized and illegal cannot be maintained after the lapse of six years from the time it was issued, during all of which time the transaction appeared fully from the books of the corporation.

In Equity. Sur pleadings and proofs upon final hearing.

James H. McCreery, for complainant.

Frank W. Smith, for defendant.

ACHESON, Circuit Judge. The complainant is the Calivada Colonization Company, a corporation of the state of Colorado, and the defendant is Milton D. Hays, a citizen of the state of Pennsylvania. The bill was filed on July 13, 1901, by A. C. Hays, as receiver of the complainant company, and in its name. He was appointed such receiver by an order of this court made on December 30, 1900, on a bill filed at No. 17, May term, 1900. The heading of the bill in this case, after naming the complainant and defendant in the usual form, proceeds thus: "With notice to Elmer E. Stewart" and 52 other named persons or corporations, who (the bill shows) respectively hold shares of the issue of stock which the bill impeaches and seeks to avoid. There is on file a paper which purports to be an acknowledgment by 17 of these persons of notice of the suit, and an affidavit of service of such notice on 10 others of the named persons. None of the 53 named persons or corporations, however, is a party to the suit. The case was set down by the parties for final hearing, and was so heard, upon the pleadings, namely, the bill, the answer of Milton D. Hays, and replication, and the proofs.

The bill sets forth that the Calivada Colonization Company is a corporation of the state of Colorado, and was incorporated on the 11th day of March, 1895, by letters patent, its authorized capital stock being \$250,000, consisting of 250,000 shares, each of the par value of \$1; that in said letters patent M. D. Hays, C. C. Marble, Frank Goodnow, and A. C. Hays were named as directors of said company; that on the 13th day of March, 1895, three of these named persons, to wit, M. D. Hays, C. C. Marble, and A. C. Hays, held the first meeting of the board of directors, the minutes of the meeting showing that M. D. Hays was president, C. C. Marble secretary, and A. B. Grindall treasurer; and that the said board of directors at that meeting adopted the following resolution:

"Resolved, that the board of directors of the Calivada Colonization Company, in consideration of the services, efforts, and information acquired and money expended by M. D. Hays in behalf of the company, hereby directs the issue to him of 126,000 shares of the capital stock at the par value of one dollar each in compensation therefor."

† 4. See Equity, vol. 19, Cent. Dig. §§ 395, 648.

The bill avers that at the time of said meeting the persons who acted as directors were not stockholders in said company, and therefore were not qualified for the office of director, and acted in violation of section 481 of the Annotated Statutes of Colorado; that at the time of the passage of said resolution the said M. D. Hays gave no consideration therefor to said company; that the purpose of the resolution was to secure to him the control and perpetual management of the company; and that soon thereafter all moneys expended by him in behalf of the company were repaid to him by the company. The bill, inter alia, avers that the defendant, Milton D. Hays, while president of the complainant company, on June 9, 1896, submitted to certain named persons now stockholders of the company a statement signed by F. R. Myers, then secretary of the company, setting forth the liabilities of the company, and that upon the presentation of this statement, or soon thereafter, the defendant, acting as president of the company, sold to these persons 40,000 shares of the company's stock; that the persons who subscribed for said 40,000 shares of stock "were not advised at the time of said subscription that the controlling interest had been fraudulently and without consideration given to the defendant"; and that the defendant "unlawfully, and with intent to commit a fraud, withheld such knowledge from the said subscribers, and in violation of his obligation to such corporation misled and deceived the said subscribers, and unlawfully secured from them their subscription and their money." The bill further avers that the "defendant never conveyed any real estate, or any option for the purchase of real estate, or gave any other lawful consideration, for the said stock issue made under the resolution of March 13, 1895"; and that "the adoption of the said resolution and the issue of said stock was a fraud on the said company, and upon all the bona fide holders and purchasers of the stock of said company, who subsequently became holders and purchasers of stock without knowledge thereof," and also in violation of the constitution and laws of the state of Colorado. The bill avers that soon after the passage of the resolution of March 13, 1895, the defendant, as president of the company, "caused a credit to be entered in the stock books of the company in his name for 126,000 shares of stock, and furthermore caused an issue to the said defendant, Hays, of certificates thereof signed by him as president, and, as shown by the record of the said company, had from time to time transferred portions of the same to persons named herein as owners thereof," and that these transferees claim and exercise control of said stock. The bill then proceeds to set forth the names of "the present holders of said stock, with the number of shares held by each, as shown by the records of said company"; and after thus naming 53 present holders of this issue of stock, with the number of shares held by each, the list concludes thus: "And M. D. Hays, 18,218." The bill avers that the present holders of "said unlawfully issued stock received the same as gifts from the said M. D. Hays," and "charged with notice of the want of consideration and unlawful issue thereof." The bill states that "this bill of complaint is filed on the written request of a majority of the board of directors of the said company, and by par-

ties owning and holding the majority of the properly issued stock of this company." The main prayers of the bill are that the court "decree that each and every share of said stock, aggregating 126,000 shares, be declared null and void, issued without consideration, in violation of law, and in fraud of the said corporation, and the rights of the bona fide owners and purchasers of the stock of said company," and that the court decree "that said stock be canceled," and the "company be reinstated in the ownership of the said 126,000 shares of stock."

The answer of Milton D. Hays, the defendant (which is under oath), responsively and fully denies all and singular the allegations of the bill upon which the supposed right of the complainant to relief rests. Specifically, the answer traverses and denies each and every averment of the bill, charging fraudulent or unlawful intent, purpose, or act in the adoption by the board of directors of the resolution of March 13, 1895, or in the issue of the stock thereby authorized, and the allegation of the want of consideration for the same, and denies that all moneys expended by the defendant in behalf of the company were repaid to him. In respect to the subscription for 40,000 shares of stock, the answer, while admitting that as president of the company, and acting under a resolution of the board of directors, the defendant sold to the named subscribers these 40,000 shares, denies that he misled or deceived them, or withheld from them any information as to the issue of the 126,000 shares to himself, and avers that they were fully advised of the said issue and of the status of affairs, and that they subscribed for and got said stock from the company at the price of only 25 cents per share. Responding to the averment of the bill that the "defendant never conveyed any real estate, or any option for the purchase of real estate, or gave any other lawful consideration for the said stock issued under the resolution of March 13, 1895," the answer states that the scheme of the Calivada Colonization Company originated with the defendant, and that he spent much time and a large amount of money in various states of the West seeking a proper location; that at a great expenditure of time and labor he had procured agreements and options for the purchase of upwards of 100,000 acres of land, and also water rights, in different parts of the West, which agreements and options were valuable, and, if properly handled, capable of yielding large profits; that he turned over to the complainant company all his said agreements and rights, and gave the company the information he had acquired, and in all things put the company in the same position he occupied himself; that the 126,000 shares of stock were issued to the defendant to recompense him for the time and money spent by him in and about the work of the organization of the company and procuring the control of said property; that it was the defendant's services and labor that made the stock of the company of any value whatever; that at the time the resolution of March 13, 1895, was passed by the board of directors, it was agreed to by every person who owned stock in the Calivada Colonization Company, and the stock was issued to the defendant with the knowledge and sanction of all the stockholders; that there was no concealment

about the transaction, but it was open to the knowledge of all stockholders. The answer further states that it was understood that the stock so issued to the defendant was to be used as he might see fit in the promotion of the said company, and in interesting such persons as he thought best in the company, and that accordingly much the greater part of said stock was transferred by the defendant to various persons for services rendered by them in said company or to interest them in its welfare, and that only about 25,000 or 30,000 shares of the stock were retained by the defendant for his own uses and purposes, which amount was a small compensation to the defendant. In respect to the present holders of said issue of stock (other than himself), the defendant in his answer states "that in most instances said stock was transferred to said parties for and in consideration of services rendered by said holders either in the promotion of said company or for services rendered to defendant, and he alleges that he had a perfect right to do with said stock as he pleased; that it was his stock, for which he had given value, and he had full right to transfer it to such person or persons as he saw fit." The answer sets forth that at the annual meeting of the stockholders of the complainant company held on March 17, 1896, as appears from the minute book of the company, the following confirmatory resolution was adopted:

"Moved by F. L. Bonta, the members of this company present ratify all the acts of the former boards of directors during the years of 1895 and up to March 17, 1896, at this meeting of the stockholders. Seconded by F. K. Higbie. Carried."

The complainant not having waived an answer under oath, and the defendant's answer being under oath and responsive to the allegations of the bill, what effect is to be given to it? This question is solved by the ruling in *Conley v. Nailor*, 118 U. S. 127, 134, 6 Sup. Ct. 1001, 1005, 30 L. Ed. 112, where the supreme court said:

"The answer, though not called for under oath, is evidence in behalf of the defendant; for, if a plaintiff in equity is unwilling that the answer should be evidence against him, he must expressly waive the oath of the defendant in his bill. See amendment to forty-first equity rule. If he fails to do this, the answer must be given under oath and is evidence."

In order to overthrow an answer responsive to the allegations of the bill, it is the universal rule that the complainant must have at least one sustaining witness and corroborative circumstances. Now, the minute book of the complainant company (in evidence) shows that the resolution of the board of directors of March 13, 1895, was spread at large upon the minutes at the date of its adoption, and that the ratifying resolution of the stockholders was entered upon the minutes the day it was passed, March 17, 1896, and the company's stock books (in evidence) show the issue of the stock in question to the defendant,—the great bulk of it on April 23, 1895,—and the various transfers of this stock by him as recited in the bill. If, then, the defendant's case rested simply upon his responsive answer and this documentary evidence, the preponderance of proof, in my judgment, would be with the defendant.

But the state of the proofs is still more favorable to the defense in view of the fact that the complainant called and examined the defendant as a witness in respect to the matters in controversy, and also by stipulation brought into the case and used the testimony of the defendant taken in a previous suit in equity in this court relating to the same matters, in which one Bimber, a stockholder of the Calivada Colonization Company, was plaintiff, and Milton D. Hays was a defendant, and in which suit the latter was called and examined by the plaintiff therein as a witness. The testimony of the defendant fully accords with and supports his answer throughout. It is true that the defendant was called and examined in this case and in the previous suit as if under cross-examination pursuant to the Pennsylvania act; but this makes no difference, as that statute is not applicable to a suit in equity in a court of the United States. *Dravo v. Fabel*, 132 U. S. 487, 490, 10 Sup. Ct. 170, 171, 33 L. Ed. 421. In that case the supreme court said:

"But that statute has no application to suits in equity in the courts of the United States. The act of congress providing that the practice, pleadings, forms, and modes of proceedings in civil causes in the courts of the United States shall conform, as near as may be, to the practice, pleadings, forms, and modes of proceedings existing at the time in the courts of record of the state expressly excepts equity and admiralty causes. 17 Stat. 197, c. 255, § 5, Rev. St. § 914 [U. S. Comp. St. 1901, p. 684]. So that, when the plaintiffs used the depositions of Dippold and Fabel, taken 'as under cross-examination,' they made those parties their own witnesses. While the plaintiffs were not concluded by their evidence, and might show they were mistaken, it could not be properly contended by the plaintiffs that they were unworthy of credit. The evidence must be given such weight as, under all the circumstances, it is fairly entitled to receive."

Applying the rules thus laid down to the present case, the fair conclusion, I think, is that the defendant's testimony has not been successfully met. It seems to me that his answer and testimony in all material respects stand unshaken. At the organization of the company he turned over to it all his agreements and options for lands, which were numerous. Many of these the company saw fit to let die. The company, however, acquired through the defendant all the lands, including the Pahrump ranch, with which it has conducted its operations. Whether or not the defendant at the date of the transaction held living written options for these lands we need not stop to inquire. The company got these lands, and got them through the defendant, and not otherwise. This is the important fact. The title, indeed, was made directly to the company, but this is not material. The result was the same, whether the legal title came to the company through the defendant as a conduit or directly from the former owners. Upon the proofs I am not persuaded that the issue of stock under the resolution of March 13, 1895, was an extravagant and unreasonable compensation to the defendant, especially in view of the understanding as to the use the defendant in his discretion was to make of the stock in promoting the interests of the company,—an understanding which the defendant seems to have faithfully carried out, reserving to his personal use a comparatively small portion of the stock. The transaction was not concealed, but was disclosed by the minute book and stock books of the company. It

had the sanction of every one then owning stock. It was open to every subsequent subscriber for, or purchaser of, stock.

Under the constitution of the state of Colorado, art. 15, § 9, and the general laws of the state, a corporation may issue stock for "labor done," or "services performed," or "property actually received." In *Land Co. v. Stevens*, 13 Colo. 534, 22 Pac. 823, it was declared that "a corporation may issue shares of its stock in payment for services rendered to it, and, where an agreement so to do is entered into in good faith, the fact that the result shows that the price agreed to be paid is extravagant does not of itself furnish a ground to release the corporation from its contract, particularly where no claim is made that the contract is prejudicial to creditors." There the court sustained an agreement by the corporation to issue 5,000 shares of stock to one who borrowed \$15,000 for it. The general rule is that to invalidate an issue of stock because of overvaluation of property received in payment it must not only be shown that there was an overvaluation, but that it was intentional, and consequently fraudulent. *I Cook, Corp.* § 35.

The bill does not allege that the subscribers for the 40,000 shares of stock had no knowledge of the fact of the issue of 126,000 shares to the defendant, but guardedly charges that they "were not advised at the time of said subscription that the controlling interest had been fraudulently and without consideration given to the defendant," etc. The defendant testifies that all of them had actual and full knowledge of that issue. There is much in the case to corroborate the defendant in this. Six of those subscribers, whose joint subscription amounted to 26,000 shares, were holders severally of shares of the 126,000 issue of stock, which shares they received from the defendant to interest them in the company, and promote its welfare, and upon no other consideration. If any of the subscribers for the 40,000 shares did not have full knowledge in respect to the issue of the 126,000 shares to the defendant, it was not because anything was concealed from them. They had the means of knowledge within reach; "and the possession of such means of knowledge is, in equity, the same as knowledge itself." *City of New Albany v. Burke*, 11 Wall. 96, 107, 20 L. Ed. 155. There is no convincing evidence to show that the defendant deceived or misled those subscribers. He made no false representation to any of them. They bought this stock from the company for 25 cents a share, one-fourth of its par value. They bought on speculation, and either knew, or might have known, upon the slightest investigation, of the prior issue of stock to the defendant and all the circumstances.

Even if the resolution of March 13, 1895, and the issue of stock thereunder, had been avoidable originally, the lapse of time before the filing of this bill, on July 13, 1901, should prevent relief. To let in such a defense it is not necessary that a foundation be laid by any averment in the answer. *Sullivan v. Railroad Co.*, 94 U. S. 806, 24 L. Ed. 324. Where the evidence discloses laches on the part of the complainant, a court of equity will refuse relief. *Id.* Nothing can call a court of equity into activity but conscience, good faith, and reasonable diligence. *Hayward v. Bank*, 96 U. S. 611, 618, 24 L. Ed. 855. In *So-*

ciété Fonciere et Agricole des États Unis v. Milliken, 135 U. S. 304, 10 Sup. Ct. 823, 34 L. Ed. 208, a delay of only two years in commencing proceedings to set aside a judgment for usury was held to be laches and fatal. In *Evers v. Watson*, 156 U. S. 527, 15 Sup. Ct. 430, 39 L. Ed. 520, the delay of complainants for four years to assert their claim was accounted good ground for denying relief. In the present case there was a delay of more than six years, which was inexcusable under the circumstances.

By the showing of the bill the defendant holds only 18,218 shares of the issue of stock sought to be avoided, the other 107,782 shares being held by persons who are not parties to the suit. Of course, upon this showing a decree for the cancellation of the whole issue could not be made even if a case for relief as against Milton D. Hays were made out. But, as we have seen, the proofs do not make out a case against him.

I observe, finally, that the creditors of the Calivada Colonization Company have no concern in this controversy. In the first place, without doubt the assets of the company are more than sufficient to pay all its debts; and, secondly, the cancellation of this stock would not increase the assets of the company.

The bill must be dismissed.

UNION TERMINAL RY. CO. v. CHICAGO, B. & Q. R. CO. et al.

(Circuit Court, W. D. Missouri, St. Joseph Division. November 19, 1902.)

1. REMOVAL OF CAUSES—SEPARABLE CONTROVERSY—JOINT ACTION.

Where a petition in a state court alleges a joint cause of action against a resident and a nonresident defendant, the cause is not removable on petition of the nonresident, unless he both alleges and proves to the satisfaction of the court that the local defendant was joined for the fraudulent purpose of preventing a removal. It is not sufficient that the petition for removal avers that the resident defendant has no interest in the controversy or that the cause of action in fact is not joint, nor that the answers raise a separable controversy or show that one of the defendants is not liable.

2. SAME—FRAUDULENT JOINDER OF DEFENDANT TO PREVENT REMOVAL.

In a proceeding by a railroad company to condemn right of way over certain lands, under Rev. St. Mo. 1899, § 1264, which provides that it shall not be necessary to make any persons defendants, unless they are either in actual possession of the premises, claiming title, or have a title of record, two railroad companies, one a foreign, and the other a local, corporation, were made defendants. It was not alleged that the local company was in possession, claiming title, and there was of record in the proper records of the county a deed which plaintiff's counsel examined before suit, by which such company had conveyed to its codefendant all of its property, real or personal, of whatever kind and wherever situated, together with all its rights and franchises, except its franchise to be a corporation. Nothing appeared from said deed to afford any reasonable ground for belief that any interest in or connected with the property which could be condemned by plaintiff remained in the local company. *Held*, that the conclusion must be drawn as matter of law,

¶ 1. Separable controversy as ground for removal of cause to federal court, see notes to *Robbins v. Ellenbogen*, 18 C. C. A. 86, and *Mecke v. Mineral Co.*, 35 C. C. A. 155.

from such facts, that the improper and unnecessary joinder of such company was for the purpose of preventing a removal of the cause by the nonresident defendant.

3. SAME—JURISDICTION OF FEDERAL COURT—PROCEEDING TO CONDEMN RIGHT OF WAY.

A proceeding instituted by a railroad company under the statute of Missouri to condemn right of way, which is a judicial proceeding under the state constitution, is a "suit of a civil nature at law," of which a circuit court of the United States is given jurisdiction by section 1 of the judiciary act of 1887-88 [U. S. Comp. St. 1901, p. 507], where there is a controversy therein between citizens of different states in which the matter in dispute exceeds \$2,000, and is removable by the nonresident defendant under section 2 of the act, although the plaintiff could not have instituted it in that court, owing to the limitation of the state statute, which confines it to a particular state court.

On Motion to Remand to State Court.

The plaintiff, a Missouri corporation, filed its petition in the state circuit court of Buchanan county, Mo., against the Chicago, Burlington & Quincy Railroad Company (hereinafter called the "Burlington Railroad"), an Illinois corporation, and the Kansas City, St. Joseph & Council Bluffs Railroad Company (hereinafter called the "Council Bluffs Railroad"), a Missouri corporation, to have condemned for the plaintiff's use certain lands at the city of St. Joseph, in Buchanan county, Mo., alleged to be owned by the defendant companies. The proceeding was had before the circuit judge in vacation, as authorized by the state statute. Summons was issued to the defendant companies, who appeared and filed answer to the petition, raising issues of law and fact as to whether the property sought to be condemned was liable to be so taken and appropriated by the plaintiff, etc. The defendant Burlington Railroad Company alleged in its answer that it was the sole owner of the property sought to be condemned, having acquired the same by deed of conveyance from the defendant Council Bluffs Railroad Company. The latter company by its separate answer alleged that it had no interest whatever in the property sought to be condemned, having hitherto conveyed all of its right, title, and interest to the Burlington Company. At the time of the filing of these answers the Burlington Company presented its petition, with sufficient bond, for the removal of the cause into the United States circuit court. After alleging that the Burlington Company was a nonresident corporation and that the amount in dispute exceeded \$5,000, exclusive of interest and costs, it set up the deed of conveyance to it from the Council Bluffs Company, and alleged that it was the sole owner of the property in controversy, and that this fact was known to the plaintiff when the petition for condemnation was filed herein, and that the resident company was made a party defendant for the fraudulent purpose of preventing the Burlington Company from removing said proceeding into the United States circuit court. The petition for removal was granted, and the plaintiff has filed a motion to remand, which has been heard and submitted on proofs.

Brown & Doran, for plaintiff.

Willard P. Hall and Mosman & Ryan, for defendant.

Before THAYER, Circuit Judge, and PHILIPS, District Judge.

PHILIPS, District Judge (after stating the facts). The first question arising on the motion to remand is whether or not the allegations of the petition for removal are true. It is a settled rule of procedure that, where the petition alleges a joint cause of action against a resident and nonresident defendant, the cause is not removable on petition of the nonresident, although it is averred in the petition for removal that the resident defendant has no interest in the controversy or that the cause of action in fact is not joint; nor is it

sufficient that the answers of the defendants raise a separable controversy, or show that one of the defendants is not liable. *Railroad Co. v. Wangelin*, 132 U. S. 599, 10 Sup. Ct. 203, 33 L. Ed. 473; *Railway Co. v. Dixon*, 179 U. S. 131-138, 21 Sup. Ct. 67, 45 L. Ed. 121. But this rule is qualified by the proviso that the defendant moving for a removal may allege and prove to the satisfaction of the court that the local defendant was joined in the action for the fraudulent purpose of preventing a removal by the nonresident defendant. To support the last averment, the defendant Burlington Railroad Company on the hearing of this motion put in evidence a warranty deed in fee from the Kansas City, St. Joseph & Council Bluffs Railroad Company to the Chicago, Burlington & Quincy Railroad Company, of date January 1, 1901, duly acknowledged and recorded in the recorder's office of Buchanan county, Mo. On its face this deed conveys and transfers to the said Burlington Company all the railroad tracks, depots, switches, property, franchises, and privileges of the said Council Bluffs Company, including its road and track and grounds in Buchanan county, Mo.; the granting clause concluding as follows:

"Together with all roadbeds, rights of way, bridges, depot and terminal grounds, and other lands or interest therein; station houses, buildings, and structures of whatsoever kind; leaseholds, rights under contract, and licenses; locomotives, cars, and other rolling stock and equipment; telegraph lines, supplies, tools, and materials; rents, profits, and income; and all other property, real or personal, of whatsoever kind and wheresoever situated, now owned by it or hereafter to be acquired, whether appurtenant to the railroad aforesaid or otherwise. Also all rights, privileges, immunities, and franchises belonging to the said first party, except its franchise to be a corporation."

On such sale and transfer from one railroad company to another, it goes without question that every conceivable interest in or right to any property (real or personal), privilege, or immunity belonging or appertaining to the grantor passes to and vests absolutely and unconditionally in the grantee. It is inconceivable that anything in the way of property rights, appurtenances, and privileges owned by the grantor at the time of the grant was reserved, "except its privilege to be a corporation." The plaintiff's counsel admitted at the hearing of this motion that before instituting the condemnation proceedings he saw and examined this deed. It is also such a well-known fact that in such matters, preliminary to the filing of such suit, counsel for the petitioner examines with care the record of conveyances to ascertain exactly where the title to the property is, that it might almost be assumed by a court that this was done. When questioned at the hearing why, in the face of this information and fact, the Council Bluffs Railroad Company was nevertheless joined as a party defendant, the answer was that the deed itself contained a reservation which counsel apprehended made it conservative to join it as a defendant. This alleged apprehension was based upon the concluding clause of the deed, which is as follows:

"And, to the end that the second party may have, hold, use, exercise, and enjoy the railroad and property and franchises of the first party hereby conveyed and intended to be conveyed, and whether now existing or hereafter acquired, as fully as might be done by the first party if this conveyance

had not been made, the first party agrees to execute from time to time any additional assignment, conveyance, or assurance, and to perform any act, which the counsel of the second party may advise; and for the purposes aforesaid the first party agrees, if the second party shall so desire and advise, that it will keep up and maintain its corporate existence and organization."

This provision of the deed was nothing more than of the nature of a covenant for further assurance, and the corporate existence of the grantor was continued merely for the purpose of enabling it, if required by the grantee, to give a further deed of assurance or affirmation. It was finally stated by counsel that, as he sought to acquire by the proceeding certain riparian rights on the Missouri river touched by parcels of the land sought to be condemned, he was apprehensive that possibly such right might be in the Council Bluffs Company, which did not pass under its deed to the Burlington Company. I confess my utter inability to grasp or to find any tangible basis for this contention. As a railroad company, under the laws and public policy of the state, neither could take nor hold any interest in land or its appurtenances, except for the necessary uses of a railroad company as such, the plaintiff has no right or authority to have condemned to its use any other property than land for its railroad. Railroads are not built on water; and the statute authorizing a railroad company to condemn property to its use has reference to such lands and property only as a railroad company may employ for trackage, switch grounds, station or depot houses, and the like. Section 1272 of the Revised Statutes of Missouri of 1899, which provides for condemnation proceedings when the property is held by a corporation, says:

"In case the lands sought to be appropriated are held by any corporation, the right to appropriate the same by a railroad company shall be limited to such use as shall not materially interfere with the uses to which, by law, the corporation holding the same is authorized to put said lands."

If the plaintiff can condemn for its use what the petition calls "riparian rights," as against the defendant railroad company, it was property held by the defendants as railroad companies, and it passed to and vested in the grantee by the all-comprehensive language of the grant. Furthermore, the allegation of the petition, in its legal effect, being that the two defendant companies jointly own the property sought to be condemned, the interest therein of the Burlington Company confessedly being derived under its grant from the Council Bluffs Company, with what consistency can it be maintained that the Burlington Company, under the grant, obtained only a joint interest with the grantor in the riparian rights? If the deed to the Burlington Company conveyed any riparian rights, it conveyed all that the Council Bluffs Company had.

It is a universal rule of law that every person is presumed to know the law. The conclusion, therefore, is inevitable that when the plaintiff joined the local company as a party defendant it knew it was not an indispensable party to this proceeding. It furthermore knew that the very statute (section 1264) under which it was proceeding declared that:

"It shall not be necessary to make any persons party defendants in respect to their ownership, unless they are either in actual possession of the premises

to be affected, claiming title, or have a title to the premises appearing of record upon the proper records of the county."

As it is not averred in the petition that the Council Bluffs Company was "in actual possession of the premises to be affected, claiming title," and it knew that it appeared "upon the proper records of the county" that the Council Bluffs Company had parted with its title, the law draws the necessary conclusion from the facts. Every man is conclusively presumed to intend the natural consequences of his act. There can be but one reasonable conclusion drawn, as matter of law, from the act of improperly and unnecessarily joining the local defendant, and that is that it was done to prevent the right of removal by the nonresident defendant. "The general legal proposition is true that where a person does a positive act, the consequences of which he knows beforehand, that he must be held to intend those consequences." *Wilson v. Bank*, 17 Wall. 486, 21 L. Ed. 723. From such a state of facts the courts have not hesitated to find, as matter of law, that the purpose of joining such a defendant is sufficient to justify the court in finding that it was done fraudulently to prevent the right of removal. *Prince v. Railway Co.* (C. C.) 98 Fed. 1-3; *Winters v. Drake* (C. C.) 102 Fed. 550; *Diday v. Railroad Co.* (C. C.) 107 Fed. 565.

A more serious question is presented touching the removability of this proceeding under the judiciary act of 1887, as amended in 1888 [U. S. Comp. St. 1901, p. 507]. The first section of this act declares that:

"The circuit courts of the United States shall have original cognizance, concurrent with the courts of the several states, of all suits of a civil nature at law or in equity where the matter in dispute exceeds, exclusive of interest and costs, the sum or value of two thousand dollars, and arising under the constitution or laws of the United States, or treaties made," etc., "under their authority, or in which controversy the United States are plaintiffs or petitioners, or in which there shall be a controversy between citizens of different states, in which the matter in dispute exceeds, exclusive of interest and costs, the sum or value aforesaid."

This is practically the same as the corresponding section of all the antecedent judiciary acts. That such a condemnation proceeding as this, under the judiciary act of 1875, which provided for the removal of any suit of a civil nature, at law or in equity, was removable, is not questioned. The only question under that statute was, when did the proceeding reach the stage when it could be said to be a suit pending? *Boom Co. v. Patterson*, 98 U. S. 403, 25 L. Ed. 206; *Searl v. School Dist. No. 2*, 124 U. S. 197, 8 Sup. Ct. 460, 31 L. Ed. 415; *Railroad Co. v. Jones* (C. C.) 29 Fed. 193; *Terminal Railway v. Lumber Co.*, 37 Fed. 3; *Upsher v. Rich*, 135 U. S. 464.

The contention now made is that the second section of the judiciary act of 1887-88, which authorizes the removal of causes, is distinguished from its predecessors in that it adds to the words, "any other suit of a civil nature, at law or in equity," the following: "of which the circuit courts of the United States are given jurisdiction by the preceding section;" and because, in construing this new provision, Mr. Chief Justice Fuller, in *Railroad Co. v. Davidson*, 157 U. S. 201, 208, 15 Sup. Ct. 563, 39 L. Ed. 672, following the ruling

in *Tennessee v. Union & Planters' Bank*, 152 U. S. 454-462, 14 Sup. Ct. 654, 657, 38 L. Ed. 511, said:

"The jurisdiction of the circuit courts of the United States, on removal by the defendant under this section, is limited to such suits as might have been brought in that court by the plaintiff under the first section."

It was because of this broad language we first inclined to the opinion that, unless the plaintiff might have instituted this condemnation proceeding in the first instance in the United States circuit court, the nonresident defendant was not entitled to remove it; and defendant's counsel on the argument of this case conceded as much, but, as we think, unnecessarily. It is on this branch of the case that Thayer, Circuit Judge, was requested to sit with me on the reargument thereof, which he did.

It is to be observed that the case of *Railroad Co. v. Davidson*, supra, was a suit by the assignee of a chose in action against a citizen of another state; the said nonresident citizen and the assignor of the chose being citizens of the same state at the time of the assignment. By the concluding paragraph of section 1 of the act of August 13, 1888, suits of that character have been entirely withdrawn from the jurisdiction of the federal courts. Not being, therefore, within the jurisdiction of the United States circuit court, they cannot be removed from the state court under the provisions of the second section of the act. So cases involving a federal question, as specified in the first section, are not within the jurisdiction of the federal courts, unless the petition or bill of complaint discloses the federal question on its face. It was accordingly ruled in *Tennessee v. Union & Planters' Bank*, supra, that such suit could not be removed where the federal question was not apparent on the face of the complaint. But where there is a controversy between citizens of different states, in which the matter in dispute exceeds \$2,000, exclusive of interest and costs, the suit is within the original jurisdiction of the United States circuit court by virtue of said section 1; and therefore, being within its original jurisdiction, such suit is removable under the second section of the act. A close analysis of said section 2 will show that a marked distinction is made therein between cases where the jurisdiction is dependent upon diverse citizenship and those arising under the constitution and laws of the United States, in that the latter are made removable when the circuit courts are given original jurisdiction by the preceding section, while the former may be removed when said courts "are given jurisdiction by the preceding section." As observed by the supreme court of Iowa, in a recent opinion (not yet officially published) in the case of *Myers v. Railway Co.*, 91 N. W. 1076:

"The omission of the qualifying word 'original' seems to have been designed, and compels a different construction."

In re *Stutsman County (C. C.)* 88 Fed. 337-341, the learned judge very aptly said, respecting the rulings in *Tennessee v. Union & Planters' Bank* and *Railroad Co. v. Davidson*, supra:

"An examination of these decisions will show that the limitation mentioned is based, not upon matters of procedure, but upon those elements specified as essential to jurisdiction in the first section of the act of 1887-88. To

confer original jurisdiction, the following facts, and no others, are necessary: (1) A suit of a civil nature at common law or in equity. (2) It must involve at least \$2,000, exclusive of interest and costs. (3) It must arise wholly between citizens of different states, or present one of the other conditions mentioned in the last part of the first section. A proceeding which presents these elements is within the original jurisdiction of the federal courts, notwithstanding it may involve matters of procedure which would prevent its commencement in these courts. The section defining the right of removal makes no reference to suits which have been begun in the federal courts, and the phrase, 'of which the circuit courts are given jurisdiction by the preceding section,' ought not to be considered as requiring elements not mentioned in the preceding section. The jurisdiction of the federal courts cannot be made to depend upon formal or modal matters; otherwise, it would be in the power of the states to defeat that jurisdiction entirely by hostile legislation, hedging about the commencement of suits by a statutory procedure which could not be employed in the federal courts."

See, also, *Evansville & T. H. R. Co. v. City of Terre Haute* (C. C.) 106 Fed. 545; *Kirby v. Railroad Co.* (C. C.) 106 Fed. 551.

Another difficulty in the mind of the writer of this opinion, when the motion to remand was first argued, was that the legislature of the state by its statute, which conferred upon this local corporation the right of eminent domain, a right in derogation of the common law, and the statute which conferred the right having prescribed the mode of enforcing and enjoying that right, to wit, by presenting a petition to the circuit court of the county where the land is situated, or to the judge thereof in vacation, was mandatory on the plaintiff, and that, as it might not be permitted to lodge such a petition in the first instance in the circuit court of the United States, the nonresident defendant, under the literal application of the broad language of the court in *Railroad Co. v. Davidson*, *supra*, was not entitled to remove the cause. This we are satisfied, on further examination, was a misconception. When a state legislature creates a right, not existent at common law, by which the property interests of a nonresident defendant may be taken and appropriated to the use of a corporation of the state, it certainly ought not to be held that the state legislature, having provided a judicial proceeding for the enforcement of such statute, by merely directing that such proceeding shall be brought in the state court, or in some unusual manner not adapted to the procedure in the federal courts, thereby could prevent a nonresident owner of the property sought to be appropriated from removing the case into a tribunal contemplated by the constitution of the United States, supposed to be free from local influence, to have his rights in the premises determined. To so hold would be to admit that the legislatures of the several states have the power to deprive the federal courts of a jurisdiction which was intended to be conferred upon them by the constitution and acts of congress made in pursuance thereof. Matters of mere procedure are not jurisdictional, but personal; and they may be waived. *Powers v. Railway Co.*, 169 U. S. 92, 18 Sup. Ct. 264, 42 L. Ed. 673.

Under the statute of this state authorizing the plaintiff railroad company to condemn lands to its use, which provides that such petition may be lodged in the circuit court of the county where the real estate is situated, or before a judge thereof in vacation, and providing

for the issue of summons to the defendant landowner, returnable within 10 days, the state supreme court holds that under section 20, art. 2, of the state constitution, which provides "that whenever an attempt is made to take private property for a use alleged to be public, the question whether the contemplated use be really public shall be a judicial question, and as such judicially determined, without regard to any legislative assertion that the use is public," such matter is from its inception to its end judicial in its character; that the defendant owner of the land has the right, in response to such summons, to appear before the circuit court, or the judge thereof in vacation, to challenge the right to condemn, and is entitled to be heard thereon, and from such final adjudication the right of appeal is accorded. *St. Joseph Terminal Ry. Co. v. Hannibal & St. J. R. Co.*, 94 Mo. 536, 6 S. W. 691. And again, in *Thompson v. Railway Co.*, 110 Mo. 147, 19 S. W. 77, the court said:

"The circuit courts, in condemnation proceedings, however, act from their inception judicially, though in conformity with the statutory powers."

As it appears from the answer of the nonresident defendant company, filed in this case contemporaneously with the petition for the removal of the cause, that the defendant company challenges the right of this plaintiff to have the land condemned to its use, because it had already been appropriated to the use of the defendant railroad company, its rights are therefore protected by the statutes of the state. It must follow that such a proceeding is a suit of a civil nature at common law, within the intent and meaning of section 1 of the judiciary act. Chief Justice Marshall, in *Weston v. City of Charleston*, 2 Pet. 464, 7 L. Ed. 486, speaking to the question as to what constitutes a suit, said:

"The term 'suit' is certainly a very comprehensive one, and is understood to apply to any proceeding in a court of justice by which an individual pursues that remedy which the law affords. Modes of proceeding may be various; but, if a right is litigated in a court of justice the proceeding by which a decision of the court is sought is a suit."

It may be conceded that the resident corporation, seeking the exercise of the right of eminent domain, which comes alone from the grant of the sovereign, is compelled to pursue the remedy prescribed by the sovereign, upon the well-recognized principle "that when a statute gives a new and extraordinary remedy, and directs how the right to the remedy is to be acquired or enjoyed, how it is to be enforced, the act should be strictly construed; and the steps pointed out for the enjoyment of the remedy provided should be construed as mandatory, rather than directory or optional." *Lumber Co. v. Hubbert*, 50 C. C. A. 435, 112 Fed. 718-725; *Sidway v. Live Stock Co.* (C. C.) 116 Fed. 389. But this restriction upon him is quite distinguishable from the rights of the nonresident property owner. His right of property in the subject sought to be appropriated by the resident corporation is under the protection of universal law, inhering in which is the right that his property shall not be taken, even for public use, without due process of law,—the right of trial before an impartial tribunal, free from local prejudice, which the federal constitution and the judiciary act were intended to secure by according

to him a hearing in a United States court. He has the right, according to common usage, to demand the process of the court to enforce the attendance of witnesses, to produce evidence governed by common-law methods and rules, and the right of appeal. So that, as between the resident plaintiff and the nonresident defendant, the proceeding once instituted thereafter partakes essentially of the nature of a suit at common law.

In a condemnation proceeding the courts of Missouri act as in other trials at law. They are governed by the same rules of evidence. They settle issues of fact and issues of law as they arise as in other cases, notwithstanding the fact that the proceeding is statutory and somewhat summary in its character. It would therefore seem that if a nonresident's property is sought to be taken and subjected to a public use, as claimed by this plaintiff, he should be entitled, if he so elects, to have a federal court determine whether or not the conditions upon which the local laws authorize his property to be condemned have been fairly and fully complied with, because by the statute the local court is empowered to hear and decide such questions as between a local corporation and a citizen of the state; and this, notwithstanding the local plaintiff, invoking the privileges conferred by the local statute to exercise the right of eminent domain, may be required on his part to initiate the proceeding in the form and before the tribunal prescribed by the statute conferring the right. When the case has been removed into the federal court, it can and should pursue the course of procedure in the trial of the issues and the appointment of commissioners as prescribed by the local statute. By this course both the form and substance are observed and preserved.

It results that the motion to remand is denied.

THAYER, Circuit Judge, concurs.

EDWARD THOMPSON CO. v. AMERICAN LAW BOOK CO.

(Circuit Court, S. D. New York. October 3, 1902.)

1. COPYRIGHTS—INFRINGEMENT—PLEADING—ALLEGATION OF OWNERSHIP.

Where a bill alleged that complainant was the owner of the copyrighted work known as the "American and English Encyclopædia of Law" and the "Encyclopædia of Pleading and Practice," and charged that the volumes of such work were edited, prepared, and published by and under complainant's direction, at great expense, from original sources, complainant being at great expense in collecting the cases and authorities therein cited, and searching for judicial precedents, and in discussing and formulating the propositions of law therein contained, and in presenting, selecting, and arranging the matter contained in said books, the bill sufficiently alleged how complainant became the proprietor of the work.

2. SAME—RECORD OF COPYRIGHT.

Rev. St. § 4964 [U. S. Comp. St. 1901, p. 3413], provides that every person who, after the "recording of the title" of any book, and depositing two copies thereof, etc., does certain acts prohibited, shall be liable for damages for infringement of copyright, and section 4953 [U. S. Comp. St. 1901, p. 3407] declares that copyrights shall be granted for the term of

28 years from the time of "recording the title" thereto. *Held* that, though the title of a publication sought to be copyrighted may be regarded as recorded when received for record by the librarian of congress, under Rev. St. §§ 4956, 4957 [U. S. Comp. St. 1901, pp. 3407, 3409], a bill for infringement failing to allege that the titles of the alleged copyrighted books had been recorded by the librarian of congress was demurrable.

8. SAME—UNFAIR COMPETITION—SEGREGATION.

Where a bill for infringement of a copyright on legal publications charged that defendant has, as a substitute for and in lieu of a resort to original sources, unfairly used the results of complainant's publications, and has incorporated such results in defendant's publications, and that such publications are to a large extent the product of complainant's original work, rewritten so as to conceal the fact that it was pirated, and that defendant, instead of resorting to original sources, to a large extent has obtained the information contained in its publications from complainant's publications, it sufficiently alleged defendant's unfair competition, and that it was impossible to segregate the particular portions complained of.

Walter Large and Frank P. Prichard, for complainant.
Augustus T. Gurlitz, for defendant.

TOWNSEND, Circuit Judge. The complainant alleges, *inter alia*, as follows:

(1) That it is the author and proprietor of the publications known as the "American and English Encyclopædia of Law" and the "Encyclopædia of Pleading and Practice."

(2) That it complied with the legal requirements necessary to establish its right to copyright by duly depositing in the mail a printed copy of the title of each of the volumes in which copyright is claimed, together with the statutory fee for recording the same, and also deposited in the mail two copies of each of said copyrighted books.

(3) That defendant has caused to be prepared and is selling in competition with complainant a book known as "Cyclopædia of Law and Procedure," containing a large amount of complainant's original copyrighted matter taken, copied, and pirated from complainant's publications, and in preparing the same

"Has, as a substitute for and in lieu of a resort to original sources, unfairly used the results of your orator's publications aforesaid, and has incorporated such results in defendant's publications; and defendant's said publications are to a very large extent the product of your orator's original work, rewritten as to form, and with changes, omissions, and additions made by defendant, so as to conceal the fact that it was the product of your orator's original work as aforesaid; that defendant, instead of resorting to original sources for citation of cases, definitions of terms, statements of legal principles, and similar legal information, has to a very large extent obtained the same from your orator's said publications, thereby unfairly availing itself of your orator's original work,—the results of which it published as its own original work, in unfair competition with your orator's publications, and in violation of its copyrights as aforesaid, and to the great injury and irreparable damage of your orator in its business, and for which it cannot be compensated in damages in an action at law."

The defendant demurs, *inter alia*, as follows:

"First. That it appears by said bill that the author of each and all of the forty books in said bill alleged to have been copyrighted by complainant is a corporation organized under the laws of the state of New York, and is a

mere legal fiction, and not an author entitled to copyright within the meaning of the laws of the United States, in that it is incapable of intellectual labor, incapable of begetting children.

"Second. That it does not appear by said bill that the author or authors, if any there be, who is or are entitled to copyright under the laws of the United States, of any of the forty volumes alleged to have been copyrighted by complainant, is a citizen or subject, or are citizens or subjects, of any state or nation whose citizens or subjects are entitled to the benefit of the copyright laws of the United States.

"Third. In that it does not appear by said bill how the complainant became the proprietor of the books of which in said bill it claims to be proprietor.

"Fourth. That it does not appear by said bill that the title of any of the forty books alleged to have been copyrighted by complainant has at any time been recorded by the librarian of congress."

"Sixth. That it appears by said bill that the same is exhibited against this defendant for the pretended infringement of a great number of alleged copyrights, to wit, forty alleged copyrights, claimed by complainant, by the alleged publication by defendant of two books designated in said bill as volumes one and two, and it does not appear by said bill which of said alleged copyrights, if any, is pretended to be infringed by said volume one, and which of said alleged copyrights, if any, is pretended to be infringed by said volume two."

The first three grounds of demurrer raise the question as to the sufficiency of the allegation that the complainant corporation is the proprietor of the alleged copyrighted books. The defendant contends: (a) That the copyright statute contemplates under the term "author" only natural persons, who, by their own intellectual labors, have produced a work; and (b) that, when a party sues as proprietor, he must set forth the name of the author or authors of the work, and show how he acquired title thereto. It is conceded that the question whether a corporation can be an author within the meaning of the copyright laws has never been decided. It is not necessarily involved in the disposition of this demurrer, and need not be discussed. It sufficiently appears that complainant's publication is the result of the intellectual labor of the editors and compilers employed by complainant. It is unnecessary, as it might be impracticable, to set forth the names of the persons engaged in the preparation of the work. It appears from the bill that the publications in question comprise some 40 volumes

"Designed to give a complete statement of the law on the subjects touched upon therein, and, together with their continuations now in the course of preparation, designed to cover all American and English substantive law, and the practice and procedure in the courts of the United States, both state and federal, and to form a complete and practical working library for the members of the bench and bar in this country; that said volumes were edited, prepared, and published by and under the direction of your orator at great expense, from original sources, your orator being at great expense in collecting the cases and authorities therein cited, and searching for judicial precedents, and in discussing and formulating the propositions of law therein contained, and in presenting, selecting, and arranging the matter contained in said books."

If defendant's contention that one who sues as proprietor must show how he became proprietor be admitted, the allegations upon this point are still sufficient. "It seems equally clear that under his contract, which made it Ewald's duty while a salaried employé of complainant,

inter alia, to compile, prepare, and revise the instruction and question papers, the literary product of such work became the property of the complainant, which it was entitled to copyright, and which, when copyrighted, Ewald would have no more right than any stranger to copy or reproduce." *Colliery Engineer Co. v. United Correspondence Schools Co.* (C. C.) 94 Fed. 152, 153. "If they were proprietors of the whole book, they were, of course, proprietors of every part of it, including the engraving, and the article in reference thereto contained in such book. Averment of proprietorship is sufficient, under the authorities. When the proofs are taken, complainants will no doubt have to show who was the author or designer of the article and of the illustration, and how such article and illustration came into their possession as proprietors, but it is not necessary in the bill to set forth the chain of title." *Lillard v. Association* (C. C.) 87 Fed. 213.

The fourth ground of demurrer is based on the failure of complainant to allege that the titles of the alleged copyrighted books have been recorded by the librarian of congress. Sections 4964 and 4953 of the Revised Statutes [U. S. Comp. St. 1901, pp. 3413, 3407] provide as follows: Section 4964: "Every person who, after the recording of the title of any book, and the depositing of two copies of such book," etc., does the acts prohibited, shall be subject to the damages, etc., prayed for by complainant; and, so far as appears by the bill, no record of any of such titles has ever been made. Section 4953: "Copyrights shall be granted for the term of twenty-eight years from the time of recording the title thereof, in the manner hereinafter directed." In *Higgins v. Keuffel*, 140 U. S. 435, 11 Sup. Ct. 733, 35 L. Ed. 470, Mr. Justice Field says:

"The copyright is secured when the registration is complete and a certificate of the registration is given by the commissioner; just as under the former law it was secured when the proper filing had been made with the librarian of congress, and his certificate was issued."

Defendant, therefore, contends that there can be no copyright until the title has been recorded. Sections 4952 and 4956 of the Revised Statutes [U. S. Comp. St. 1901, pp. 3406, 3407] provide that the author or proprietor shall have the sole liberty of printing and publishing his composition upon complying with the provisions as to deposit in the mail, and by section 4957 [U. S. Comp. St. 1901, p. 3409] the librarian of congress is obliged to record the name of such composition. It may be admitted that the title is in law recorded when received for record, and that the date of the recording is the time when it is so received, rather than that when it is actually written in the record book. But in view of the express language of the statute, limiting the duration of the grant "from the time of recording the title," and providing for the recovery of damages "after the recording of the title," it would seem that the fact of record should be alleged in the bill, even if the delivery to the librarian is sufficient evidence of the fact.

The sixth ground of demurrer must be overruled. The allegations of the bill already quoted sufficiently show unfair competition on the part of defendant, and that it is impossible to segregate the particular

portions complained of. "In such a condition of affairs, where, by the conduct of defendant's employés, a part of complainant's copy-righted work has been appropriated by defendant, and so mingled with original matter contained in its publication that no one except its own employés who did the wrong can segregate the pirated from the original matter, and they do not make such segregation, the whole work, or so much of it as is tainted by the workmanship of the unfair users, should be enjoined and accounted for." *West Pub. Co. v. Lawyers' Co-operative Pub. Co.*, 25 C. C. A. 648, 79 Fed. 756, 35 L. R. A. 400.

The demurrer is sustained as to the fourth ground thereof, with leave to complainant to amend, and is overruled as to all the other grounds, without costs to either party.

GANNETT v. RUPPERT.

(Circuit Court, S. D. New York. September 5, 1902.)

No. 4,770.

1. TRADE-NAMES—TITLE OF PERIODICAL—RIGHT TO PROTECTION AGAINST INFRINGEMENT.

The publisher of a periodical has a property right in its name which a court of equity will protect against infringement by the use by another of such name, either alone or with other words, as the name of a similar publication, whenever damages are caused by such use; but it is essential to the right to relief that the adoption of the name by defendant should have been with intent to deceive, or that its use by him is calculated to deceive persons of ordinary intelligence and care, and thereby cause injury to complainant.

2. SAME—PERIODICALS NOT COMPETING.

Complainant published in Maine a periodical under the name of "Comfort," which circulated chiefly in country districts, and contained stories and advertisements of concerns desiring to reach that class of readers. Later defendant started a periodical which he named "Home Comfort." It was published in New York, and treated of the care and hygiene of infants, and its advertising matter was largely of a different character from that of complainant's publication. The two publications were different in size, appearance, and price, and there was no evidence of any intention on the part of defendant to deceive either purchasers or advertisers. *Held*, that the two publications were not in fact competitors, and that complainant was not entitled to an injunction restraining defendant from using the word "Comfort" in the name of his paper, in the absence of proof that deception or confusion actually resulted to his injury.

In Equity. Suit to enjoin infringement of trade-name. On final hearing.

Archibald Cox, for complainant.

James D. Fessenden, for defendant.

HAZEL, District Judge. This suit was commenced to enjoin the use of a trade-name and to recover damages for its infringement. The predecessor of the complainant corporation in the year 1888 began the publication of a monthly periodical to which was given the name or title "Comfort." It is still so known. The name had not been previously used for any other publication, and the use thereof

since its adoption has been uninterrupted and exclusive by the complainant and its predecessor. Large sums of money have been expended to improve "Comfort's" appearance and increase its circulation. Its principal readers and subscribers reside in rural localities. On account of the extensive circulation which it has acquired, "Comfort" is a valuable advertising medium for the sale of articles and proprietary drugs. It obtains for advertising space quite large remuneration. Every issue contains 24 pages, of four columns each, the size of the page being 11½ by 17 inches. It publishes short stories contributed by its subscribers, abridged current events, and reproduces pictures of prominent men, with short biographies. "Comfort" principally aims to attain distinction as a widely circulated monthly periodical among country folk and to satisfy the advertiser. It is published at Augusta, Me. Its name is printed at the head of the title page in red letters, horizontally cut by a yellow key, which passes through the letters all on one line. Underneath the title appear in explanation the words, "The Key to a Million Homes." The bill, after charging that the defendant intentionally and fraudulently publishes a monthly periodical the name or title of which is "Home Comfort," invokes the power of this court to restrain defendant from appropriating the word "Comfort" in connection with the name or title to his periodical. The defendant, by his answer and proofs, contends that his use of the words "Home Comfort" as the name or title of his publication is lawful, and further avers substantially that his periodical differs from the complainant's to such an extent that no person is deceived or led to purchase defendant's periodical intending to purchase that of complainant. The adopted name has not been registered. A common-law trade-name is sufficiently established. The parties to this suit are residents of different states. The complainant is incorporated under the laws of the state of Maine, and it has offices in Augusta, Boston, and Temple Court, New York. The defendant is a resident of New York City, and conducts his business in that city at No. 114 Fifth avenue. I think the crucial test in this case must be whether the proofs justify the finding by the court that the periodical "Home Comfort" is a similar publication to that of complainant, and whether its distribution under that name deceives the public, and inflicts injury upon the complainant, owner of "Comfort." It has been repeatedly held by the courts of the United States and of the state of New York that there is a property right in a name which may be protected by a court of equity. Complainant is entitled to his trade-name as applied to his periodical, and may avail himself of the same remedies to enforce his rights that are open to a tradesman whose goods have become distinctively known to the public by the use of a technical mark or name which differentiates them from the goods of another of like kind. Sebastian, Trade-Marks (4th Ed.) 291. The foundation of complainant's claim lies in priority of appropriation and exclusive right to a trade-name as applied to a publication. A trade-mark as applied to a periodical or publication is somewhat different from a mark, name, or symbol by which the products of a particular merchant may become known. Names, however, which are ordinarily used to make periodicals, mag-

azines, and newspapers known to the public are governed by the same general principles which apply to a trade-mark actually affixed to an article of manufacture and sale, and adopted to denote origin and ownership. A court of equity will interpose to protect such right whenever damages are caused by the infringement. *Sebastian, Trade-Marks*, 291; *Fairbanks Co. v. Luckel, King & Cake Soap Co.*, 42 C. C. A. 376, 102 Fed. 327. Such names as "Chronicle" (46 Law T. [N. S.] 897), "Mail" (54 Law J. Ch. 1059), "Post" (37 Ch. Div. 449), "Advocate" (*Snowden v. Noah, Hopk. Ch. 347, 14 Am. Dec. 547*), "News" (*Forney v. Publishing Co. [Sup.] 10 N. Y. Supp. 814*), "Commercial" (*Association v. Haynes, 26 App. Div. 279, 49 N. Y. Supp. 938*), when applied to newspapers and periodicals, have been held not to be infringed, because the right to the use of the name was invoked without proof of deception or injury to the original user of the name. In the case of *Association v. Howard (C. C.) 60 Fed. 270*, it was held that "Social Register," compiled by its publisher with reference to the personal and social standing of certain persons residing in Orange, N. J., constituted a valid trade-mark, and the defendant having published a similar list of persons residing in the same place, which he called "Howard's Social Register," was enjoined; the court holding that the latter publication bore some resemblance to complainant's publication, and that defendant encroached upon complainant's acquired rights. It should be observed in that case that defendant's publication admittedly was a rival, and the list of persons was from the same locality. It is not enough that a complainant is able to establish that a word used as a trade-mark or name should be appropriated by another who uses that word with others to designate his periodical or magazine. A property right in a name to a periodical undoubtedly exists, and no one has a right to use that name in connection with a similar publication. The supreme court has held (*Saxlehner v. Eisner & Mendelson Co., 179 U. S. 33, 21 Sup. Ct. 7, 45 L. Ed. 60*) that it is not necessary to constitute an infringement that every word of a trade-mark should be appropriated. It is sufficient that enough be taken to deceive the public in the purchase of a protected article. *Manufacturing Co. v. Ludeling (C. C.) 22 Fed. 823*; *Church & Dwight Co. v. Russ (C. C.) 99 Fed. 276*. The infringement, however, must be clearly shown, the basis for which is the use of the name for a similar purpose, and under circumstances of assimilation resulting in confusion and deception upon the public which produce injury to the proprietor in the loss of custom or patronage. *Snowden v. Noah, Hopk. Ch. 347, 14 Am. Dec. 547*; *Bell v. Locke, 8 Paige, 75, 34 Am. Dec. 371*. The governing rule is well set out in *Association v. Haynes, 26 App. Div. 279, 49 N. Y. Supp. 938*. The court, speaking by Mr. Justice Barrett, says:

"That rule is that while the court will undoubtedly afford relief against such a simulation of the plaintiff's publication as is calculated to mislead the public, and consequently to injure the newspaper's circulation and patronage, yet it will not interfere where no harm had been done to the plaintiff or is likely to be done to him by the publication complained of."

The court agrees with the inferior court that the "adoption of a name which, though not an exact imitation of the whole name used

by the injured party, is calculated to deceive and mislead, may be enjoined."

Applying the enunciated principles of law to the case at bar, the following question is presented for determination: Are the facts shown by complainant such as to justify the conclusion that the use of the word "Comfort" in conjunction with the word "Home," as applied by the defendant to his particular publication, tends to deceive any purchaser or advertiser of "common intelligence and observation"? Counsel for complainant contends that the rule laid down in the last-mentioned case does not apply, as in that case the name "Commercial" is descriptive, and not susceptible of monopolization; that the word "Comfort" is an arbitrary designation of complainant's periodical, and therefore the essence of the injury is the taking of the trade-mark or name by the defendant. Nevertheless, the relief sought will not be granted unless it appear satisfactorily that there was a probability of injury to complainant by which he suffered either a pecuniary loss or such embarrassment or confusion as would tend to injury. It cannot be seriously claimed there is any similarity of appearance between the two periodicals. The word "Comfort" is used in the title, but no other similarity is apparent. Defendant's witness Leonard, in addition to pointing out the dissimilarities in the two periodicals, makes clear the difference in advertising. He says: "One is a mail-order advertising sheet, one reaching people remote from the stores, who buy by mail, while the other reaches people in towns and cities, who buy from stores." The price per copy of "Home Comfort" is five cents, while that of "Comfort" is twenty-five cents per annum. Its title page is printed in blue. In the center it has an oval picture of a nude infant. Complainant's title page is highly colored,—red and yellow,—with figures of different colors. Defendant's title page announces that it is published by "W. F. Ruppert, 114 Fifth Ave., N. Y. City." It is about half the size of complainant's publication, and is devoted entirely to the publication of articles containing suggestions and advice to mothers touching infants' ailments, their nurture, and hygienic betterment. The initial pamphlet published by defendant was named "Baby's Comfort." Subsequently that name, for what reason does not appear, was changed to "Home Comfort." Defendant claims to have had the consent of complainant to the use of the title "Baby's Comfort." This, however, is denied by complainant. Assuming that he did acquiesce in the use of the title "Baby's Comfort," it, nevertheless, appears by the correspondence that passed between complainant and defendant before this action was commenced that complainant objected most strenuously to defendant's use of the name "Home Comfort" for his periodical. He repeatedly endeavored to put a stop to such use. Such acquiescence, if established, would be no excuse for infringement. *Menendez v. Holt*, 128 U. S. 514, 9 Sup. Ct. 143, 32 L. Ed. 526; *Saxlehner v. Eisner & Mendelson Co.*, supra. Prior to the change of name, defendant on several occasions called at the business place of complainant to dispose of a list of names of persons to whom sample copies of his publication might be sent. These visits may have suggested to defendant "Home Comfort" as a better name

for his publication than "Baby's Comfort"; that it would more quickly appeal to intending subscribers for his periodical and better give an intimation of the contents. That is not enough. The defendant has not taken the specific name of complainant. Has the appropriation by defendant of the word "Comfort" as part of a trade-name deceived any one? Has it injured complainant? Would the title of "Home Comfort," as applied to defendant's publication, deceive an intending purchaser of ordinary intelligence in the mistaken belief that he was purchasing complainant's magazine? I have examined the testimony quite carefully to satisfy myself on this point. I do not believe either that an intending purchaser of "Comfort" would be misled into purchasing the other periodical if he purchased with usual care, or that defendant in designating his periodical did so with intent to pass it off as that of complainant. "Home Comfort" is peculiarly interesting to its readers because of special subjects published therein which are instructive to those who have the charge and care of infants. Obviously, such a periodical falls into quite different hands than a periodical like "Comfort," which is devoted to fiction, illustrations, and advertisements, and does not contain any of the features of the former publication. These periodicals are not rival competitors. Nor is the claim tenable that advertisers in "Home Comfort" are misled into believing that they are advertising in "Comfort." Undoubtedly those who advertise in "Comfort" also advertise in other newspapers or periodicals having a circulation in the rural districts. I am convinced that no advertiser in defendant's publication is deceived into the belief he is advertising in complainant's. It appears by complainant's proofs that on several occasions letters intended for "Comfort" were addressed "Home Comfort," Augusta, Me. As these letters reached complainant in the ordinary course of mail, it cannot reasonably be claimed that any confusion was caused by the manner of addressing.

Complainant argues that the word "Comfort" has become so intimately associated with "Home Comfort" as applied to complainant's periodical that some of its subscribers address their communications to complainant by the latter designation. It does not appear that letters so addressed have been delivered to the defendant by mistake. In a few instances letters addressed to "Home Comfort" were delivered at complainant's New York office. On opening them it was ascertained that such letters were not intended for complainant, but were intended for defendant. Such mistakes often occur where the slightest similarity of name is apparent. The confusion, if such it be, is not so extensive as to be productive of injury. I am persuaded that the similarity of the names of complainant's and defendant's periodicals does not, standing alone, furnish competition or rivalry injurious either to the public or to the complainant. In the case of *Publishing Co. v. Dobinson* (C. C.) 82 Fed. 56, Judge Wellborn holds that a corporation is not entitled to an injunction restraining another corporation from using the same corporate name or publishing in a distant state a periodical having a name similar to one published by complainant. In that case complainant's publication was designated "United States Investor." It was a weekly trade and financial jour-

nal. Defendant's publication was called the "Investor." Complainant's paper was published in the cities of Boston, New York, and Philadelphia. Defendant's paper was published in the city of Los Angeles, state of California, and was also devoted to the publication of matters of trade and finance. The court became satisfied that the words "Los Angeles, California," the headline on the editorial page of defendant's journal, and other distinguishing characteristics of said journal, as well as the publication in a city distant from complainant, together with the absence of any evidence of damage or injury to complainant, presented such a state of facts as to be controlling. He refused to allow an injunction, and dismissed the bill. In the case of American Grocer Pub. Ass'n v. Grocer Pub. Co., 25 Hun, 398, the facts are quite distinguishable from these here under consideration. In that case both papers were in pamphlet form, and of about the same size, and were addressed to similar subjects. Defendant's paper was started in the same block in New York City, and was edited by a former editor of complainant. The court said that there were strong circumstances tending to establish the fact that the original design was to encroach upon the plaintiff's business. Complainant's proofs fall short of establishing such a state of facts. Complaint dismissed, with costs.

McCORMICK v. SHIPPY.

(District Court, S. D. New York. December 1, 1902.)

1. CHARTER PARTY—DEMISE OF VESSEL—STIPULATION RELIEVING CHARTERER FROM LIABILITY FOR NEGLIGENCE OF MASTER.

A time charter of a steam yacht, to be delivered in commission, contained a provision that "the charterer shall assume no responsibility for loss or damage to the yacht," and a clause in the printed form requiring the charterer to keep the vessel insured for the benefit of the owner was stricken out. It also provided that the hire should continue until her redelivery in good condition, "unless lost," and that, in case of her loss during the term, hire paid in advance and not earned should be returned. She was delivered in commission, and the officers and crew were retained by the charterer; the master being recommended by the owner as competent to navigate the yacht, both as master and pilot, in any waters within the limits of the contract, in conjunction with local pilots. The charterer had no knowledge of navigation, and accepted and relied upon the master in all respects. The yacht was lost through the negligence of the master in failing to take a pilot in waters with which he was unfamiliar, though his taking one was suggested by the charterer. *Held* that, although the charter was a demise of the vessel, which made the master the agent of the charterer, who would be responsible for his negligence to third persons, and ordinarily as between the parties, he was protected from liability to the owner for the loss of the yacht by the provisions of the charter, by which the owner clearly assumed the risk of such loss.

2. SAME—VALIDITY—PUBLIC POLICY.

A stipulation, in a charter demising a vessel, by which the risk of loss or damage to the vessel through the negligence of the master, which the law would otherwise cast upon the charterer, is assumed by the owner, is not invalid as against public policy.

In Admiralty. Action by owner against charterer, to recover for loss of vessel.

Alexander & Ash, Robert D. Benedict, and Mark Ash, for libellant.
Perkins & Jackson, Charles C. Burlingham, and Edward C. Perkins,
for respondent.

ADAMS, District Judge. This is an action brought by the libellant, as owner of the steam yacht "Rapidan," against the respondent, as charterer of the yacht, for the loss of the yacht on Cape Henlopen, on the 10th day of September, 1901. The agreement between the parties was contained in a charter party of which the following is a copy:

"Time Charter.

"This agreement made and concluded upon in the City of New York the 23rd day of March, 1901, between R. Hall McCormick, owner of the screw steam yacht Rapidan, of Oswego, N. Y., of 82 tons gross register and 58 tons net register and provided with the proper certificate for hull and machinery and valued at \$20,000, and Henry L. Shippy, Treasurer, charterer,

"Witnesseth: that the said owner agrees to let and the said charterer agrees to hire the said steam yacht from Aug. 15th, 1901, to September 15th, 1901, to be placed at the disposal of the charterer at New York, N. Y., and being on her delivery tight, staunch, strong and fitted for service, including necessary equipment, to be employed as a private yacht for use on the coast and inland waters of the United States north of Cape Hatteras as the charterer shall direct, on the following conditions:—

"1. That the charterer shall provide and pay for all coal, port charges, pilotage, provisions, wages of crew, deck, engine room and other necessary stores and all other charges whatsoever and shall maintain the yacht in a thoroughly efficient state, in hull and machinery, for and during the service.

The yacht to be ^{delivered} put in commission by the owner.

"2. ~~That the yacht shall be insured for the benefit of the owner and That~~ ^{to the yacht.} ~~the charterer shall assume no responsibility for loss or damage, covered by the terms of said insurance. The premium on the policy of insurance to be paid by the charterer.~~

"3. That the charterer shall accept and pay for all coal in the yacht's bunkers at the time of delivery and that the owner shall on expiration of this charter party pay for the coal left in the yacht's bunkers at the current market prices at the port of New York.

"4. That the charterer shall pay for the use and hire of said yacht the sum of \$3,500, Thirty Five Hundred Dollars, commencing on and from the day of her delivery as aforesaid and at and after the same rate for any additional time; hire to continue until her delivery in like good order and condition to the owner, unless lost, at New York, N. Y.

"5. Payment of hire to be made in cash, in advance, as follows:— The full charter price on delivery of yacht to charterer and in default of such payments, the owner shall have the privilege of withdrawing said yacht from the service of the charterer without prejudice to any claim the owner may otherwise have on the charterer in pursuance of this charter.

"6. That should the yacht not be ready on or before August 15th, 1901, charterer to have the option of cancelling this charter at any time not later than day of yacht's readiness.

"7. That should the yacht be lost, hire paid in advance and not earned, reckoned from the day of her loss, shall be returned to the charterer.

~~"8. That the charterer has the option at any time during the term of this charter of purchasing the said yacht for the sum of _____ against which any amount paid for the hire of the yacht shall be set off and deducted.~~

"9. That should any dispute arise between the owner and the charterer, the matter in dispute to be referred to three persons in New York, one to be appointed by each of the parties hereto and the third by the two so chosen.

Their decision or that of any two of them shall be final. And for the purpose of enforcing any award, this agreement may be made a rule of the court.

"10. Penalty for non-performance of this contract shall be the estimated amount of damages.

R. Hall McCormick, Owner.
Charterer.

Frank Bourne Jones.

Witness.

Witness.

Charter extended to Oct. 31st for \$3000 additional as per agreement.

June 10th, 1901. P 437 Letter Book 34.

Aug. 16th Recd \$6500.00 on the above being

1901 the full amt of the charter money.

R. Hall McCormick."

The yacht was delivered to the charterer at New York on the 15th day of August, who ran her from that time until she was lost. The libel alleges, and the answer denies, that the respondent was in sole charge of the vessel at the time she was lost; that she was lost while she was in the possession of the respondent and being navigated by him and in consequence of his negligence and his failure to fulfill the terms of the contract in providing a competent master and crew, or licensed pilot, and in manning and equipping the vessel and maintaining her in an efficient state. Further answering, the respondent relies for exoneration upon the terms of the contract, particularly wherein it was provided that though the charterer was to pay the wages of the crew, the vessel was to be delivered in commission by the owner and that the respondent should assume no responsibility for loss or damage to the yacht, and alleges that the yacht was delivered to the respondent in commission under the command of a master and manned by officers and crew selected and hired by the libellant, all of whom, with unimportant exceptions, continued to serve on the yacht until she was lost and that at all times the yacht remained under the command of the said master and at no time did the respondent, either personally or by any agent, take charge of the yacht or any part in her navigation. It is further alleged that the loss was due to perils of the seas.

I find that the yacht was delivered to the charterer in conformity with the provisions of the contract and remained under the charge of the master who had been for some time before employed by the owner when the yacht was in his own service and who was regarded by him as entirely competent to navigate the yacht, both as master and pilot, in any waters with which he was familiar, and in any waters within the limits of the contract, in conjunction with local pilots. The owner recommended the master to the charterer fully in these respects and he was accepted and relied upon by the latter, who was not himself competent to navigate the yacht, in all respects in which a yacht owner or charterer might reasonably depend upon an expert navigator. During the earlier part of the chartered period, the yacht had been employed in trips east, through Long Island Sound. Upon one of these trips, the charterer had mentioned to the master a possible trip to the Delaware Bay in the vicinity of Cape May, and on the 8th of September, when the yacht was in New York Harbor, the charterer gave orders to the master to fit her out for such trip. The master was not familiar with the waters of Delaware Bay, or the approaches thereto, but said there would be no difficulty in mak-

ing a daylight run and asked for charts of the vicinity, which the charterer provided. The start was made on the 10th, though not at as early an hour as was expected and it was getting dark when the vicinity of Atlantic City was reached but the master did not suggest the necessity of making harbor there and the charterer, relying upon the master's ability to navigate the yacht safely to her destination, gave no order for a harbor. The weather was very fine at the commencement of the voyage, but it had become somewhat overcast and the sea had increased, with a southerly breeze, but there was nothing then to excite apprehension, and the voyage continued. About 8 o'clock in the evening the vicinity of Cape May was reached. At this time the sea was rough enough to affect this small yacht and the master concluded to seek the shelter of the Delaware Breakwater, near Cape Henlopen, instead of going to Cape May, as originally intended. He had been studying the charts on the way down and concluded that he was competent to navigate the vessel in to the harbor without the aid of a pilot and was so confident of his ability that he not only did not seek a pilot but suffered a steam pilot boat to pass him, without observing her, or her signalled offer to furnish a pilot, notwithstanding the charterer, and a guest who was with him, suggested to him that a pilot should be obtained. Proceeding with a view that he understood the situation, having passed the Overfalls Lightship on his port hand, he steered, as he thought, for an entrance to the Breakwater harbor, but made no allowance for a strong ebb tide, with the consequence that he lost his bearings and, still going ahead, brought the yacht up on the point of Cape Henlopen, where she became a total loss, fortunately without loss of life.

There can be no doubt that the loss was attributable to the master's negligence and the question to be determined is, who was responsible therefor.

It would seem that the charterer, in this case, was owner pro hac vice of the vessel. The contract was a demise of the vessel itself, with its furniture and apparel, described *locatio navis et operarum magistri* as distinguished from *locatio operis vehendarum mercium*—Abb. Ship. *46—and no difficulty could arise in determining responsibility of the charterer to third parties and ordinarily none as between the parties themselves, when negligence is shown on the part of the charterer or his agents—*Leary v. U. S.*, 14 Wall. 607, 20 L. Ed. 756; *U. S. v. Shea*, 152 U. S. 178, 14 Sup. Ct. 519, 38 L. Ed. 403; *Association v. Moore*, 183 U. S. 642, 654, 22 Sup. Ct. 240, 46 L. Ed. 366; *Dredging Co. v. Hughes* (D. C.) 113 Fed. 680—although the yacht was delivered to the charterer in commission, and the master was strongly recommended by the owner, nevertheless, the master was paid by the charterer and was subject to his directions. It is clear that the master was the agent of the charterer, as immediate owner, and that the charterer was responsible in all respects for the master's negligence, unless he had exonerated himself by a special and binding stipulation in the contract.

It is to be presumed that the legal obligation was in contemplation of the parties when the contract was entered into and it is apparent that the risk of loss was in their minds, because there were

several provisions with reference thereto. It was first provided that the charterer should assume no responsibility for loss or damage to the yacht; then that the hire should continue until the period of her return, unless she should be lost, and finally, that if the yacht should be lost, that the hire paid in advance and not earned should be returned. From these provisions, it seems plain that it was intended the owner, not the charterer, should bear the burden of the risks incident to the navigation of the vessel and such view is strengthened by the provisions with respect to insurance. The contract in the original form provided for indemnity to the owner against loss by insurance to be furnished by the charterer, so that the latter should be under no liability which was covered by the insurance but this was changed so that it was provided that the charterer should assume no responsibility for loss or damage to the yacht. It is urged by the libellant that the language employed, "loss or damage to the yacht," did not go to the extent of relieving the charterer from liability for loss of the yacht, but was only intended to cover some injury to the yacht, and not a total loss, but the intent to be gathered from the whole instrument is, I think, that the owner undertook the responsibility which would otherwise have fallen upon the charterer and it is significant of this intention that he actually indemnified himself by insurance against the loss which occurred.

I must conclude, therefore, that the charterer has relieved himself from the liability unless the contract, in such respect, is repugnant to the law. The libellant contends that it is void, citing: *The Syracuse*, 12 Wall. 171, 20 L. Ed. 382; *The American Eagle* (D. C.) 54 Fed. 1010; *The Jonty Jenks* (D. C.) Id. 1021. These cases merely hold that in a towage contract, a provision that a boat shall be towed at her own risk, does not exempt the towing boat from the consequences of negligence on her part. The point in *The Syracuse*, the leading case, was whether such a contract relieved the towing boat from the exercise of reasonable care, caution and maritime skill, and it was held that it did not, without a discussion of any principle involved. I do not see how the decision can be extended to cover a case of this character, where the parties, standing in equal relations, have entered into a contract which, as applied to the circumstances of this case as they occurred, simply meant that the charterer should not be liable for the negligence of the master of the yacht, who was recommended to him by the owner, as competent to navigate her in the waters covered by the contract, provided the charterer should furnish pilots when necessary in waters which were strange to the master. As before stated, the charterer was willing and desirous of furnishing a pilot on this occasion but the master did not consider the employment of one necessary and to hold the charterer responsible for the imputed negligence, arising from the legal relations between him and the master, in the face of the contract, would require some authorities more in point than the cited cases. No question of public policy bears upon this case and no reason appears for the impairment of the right of the private contract here, which should stand as the parties made it—Hartford Fire

Ins. Co. v. Chicago, M. & St. P. R. Co., 175 U. S. 91, 98, 20 Sup. Ct. 33, 44 L. Ed. 84; Railway Co. v. Voight, 176 U. S. 498, 505, 20 Sup. Ct. 385, 44 L. Ed. 560.

Libel dismissed.

In re TURNER.

SHERIFF v. TURNER et al.

(Circuit Court, S. D. Iowa, C. D. December 1, 1902.)

(District Court, S. D. Iowa, C. D. December 1, 1902.)

No. 2,404.

1. STATES—POWER TO ARREST UNITED STATES OFFICER.

An officer of the United States army acting in the discharge of his duty, in obedience to orders of the secretary of war, who in turn is executing an act of congress, is not subject to arrest on a warrant or order of a state court.

2. FEDERAL COURTS—HABEAS CORPUS—DISCHARGE OF STATE PRISONER.

Where an officer of the United States army, while in the discharge of his duty, in obedience to orders of his superiors, has been arrested and is being held by the authorities of a state on an order of a state court, which was without jurisdiction, the case is one of such urgency that a federal court, in the exercise of its discretionary power, will order his discharge on a writ of habeas corpus.

3. REMOVAL OF CAUSES—AMOUNT IN CONTROVERSY.

In a suit to enjoin a permanent injury to land, the value of the land determines the amount in controversy for the purposes of the jurisdiction of a federal court, and if such value exceeds \$2,000, and other jurisdictional facts appear, the cause is removable.

4. STATES—POWER TO ENJOIN FEDERAL OFFICER.

A state court is without jurisdiction to enjoin an officer of the United States army from doing a work which he is commanded to perform by his superior officer in the execution of an act of congress, and, such an injunction being void, its disobedience by the officer is not a contempt, and his arrest and detention therefor is without legal authority.

Two actions heard together. The first was a suit in equity removed from a state court, and heard on a motion to remand and a motion by defendant to dissolve an injunction. The second was a proceeding by habeas corpus in the district court by the defendant in the first suit for his discharge from arrest and detention on an order of the state court for violation of injunction.

J. H. Henderson and Howard Clark, for complainant.

Lewis Miles, U. S. Atty., and G. B. Stewart, Asst. U. S. Atty., for respondents.

Lewis Miles, U. S. Atty., and G. B. Stewart, Asst. U. S. Atty., for the writ.

J. H. Henderson and Howard Clark, opposed.

¶ 2. Jurisdiction of federal courts in habeas corpus proceedings, see note to In re Huse, 25 C. C. A. 4.

¶ 3. Jurisdiction of circuit courts as determined by amount in controversy, see notes to Auer v. Lombard, 19 C. C. A. 75; Shoe Co. v. Roper, 36 C. C. A. 459.

McPHERSON, District Judge. Both of the above-entitled causes were heard by me at the same time, and, the cases being so closely related, can be stated by me and decided in the one opinion.

The first case is a bill in equity filed in the district court of Warren county, Iowa, to restrain the defendants from laying a sewer pipe from the United States army post to what is called North river. The complainant is the owner of a tract of land a short distance below where the sewer will enter the river. North river is alleged to be a small, sluggish stream, not navigable, not meandered, sometimes no running water, at all other times with but little or no current, but at all times holding sufficient water for his cattle to drink. In April, 1900, congress passed a statute for the erection of a military post at Des Moines. Under this statute the site selected is about five miles south of Des Moines, and the sewer in question extends from the site to North river, a distance of about two miles. It is alleged that defendant Turner is in charge of the works, and that he and the defendant Herrick are constructing the works, including the sewer. It is also alleged that the discharge of the sewage will so pollute the waters and the bed of North river as to make plaintiff's lands unfit for pasture, because of the necessity for complainant's cattle to go to North river for drinking water, there being no other water for cattle on his land. The act of congress provides, first, that the site of the post shall be approved by the secretary of war. It next provides that the army post shall be of such character and capacity as the secretary of war shall direct and approve.

The defendant Turner has surveyed the same, and with the aid of defendant Herrick is constructing the sewer. It is alleged that, by making the sewer, thereby the channel of the stream will be polluted, and his land made unfit for pasture, and by reason thereof his lands will be depreciated in value; and it is contended that this is taking of private property for public use without making compensation therefor.

The state court issued an injunction, enjoining the defendants from constructing any part of the sewer in Warren county, and from having the mouth thereof at North river. The defendants, and particularly defendant Turner, disregarded the writ and refused to obey it. Thereupon he was arrested by the sheriff to answer as for contempt. Before the contempt proceedings were heard the United States attorney appeared and filed a petition to remove the case to this court on the ground of a "federal question" being involved. The removal was granted, and the record filed in this court. The complainant has filed a motion to remand, and the United States attorney moves to vacate the injunction. Shortly before the contempt proceedings were to be heard I ordered the writ of habeas corpus to issue, directing the sheriff to show by what authority he detained the said Turner. The sheriff pleads that he held him by virtue of the proceedings and orders in the contempt case.

In addition to the foregoing, it also appears that the defendant Turner is an officer in the United States army with the rank of major, and that as Major Turner, under the directions and orders of the war department, he was, in the line of military duty, erecting said post, and as part thereof was constructing said sewer.

Some minor and some technical questions have been waived, and the substantial inquiries which, by both the circuit and district courts of the United States, must now be decided are, has a state court the jurisdiction in a proceeding brought for the sole purpose of enjoining an officer of the United States army from doing a work which he is commanded to perform by his superior officer in the execution of an act of congress? And can such officer be enjoined by a state court, even though he is committing a wrong upon complainant's property, provided such act is for and on behalf of the government?

If the court had jurisdiction, then the power to issue the writ existed, and whether it was issued upon a sufficient or insufficient showing by the landowner is not a question for this court. But the question, and the only question, for this court is, did the state court have jurisdiction to proceed further, when it became known that Mr. Turner was Major Turner, and that Major Turner was doing the things complained of as an army officer, in obedience to a command by the secretary of war, pursuant to an act of congress? If there is doubt about the matter, neither of these courts should hold that the state court was without power or jurisdiction. But having no doubt whatever that the state court was wholly without jurisdiction, it is my duty to so order.

And, the state court being without jurisdiction, its writ of injunction was void, and the disobedience thereof was not a contempt, and his arrest and detention was without authority. And I deem it my duty to present, although briefly, my reasons for so holding.

And, first, as to the habeas corpus case in the district court. This writ cannot be used as a writ of error or appeal to review the action of another court. But it can and should be issued and made effective when another court has acted without jurisdiction to act. Even then, at times and in cases like this, it is discretionary. It would be proper to allow the case to take its course through the Iowa courts, the supreme court of the state included, and then, if the party arrested is adjudged against, to present the case by writ of error to the supreme court of the United States. But the arrest, under authority of a state, of a federal officer, and that officer one of the federal army in the performance of a command by a superior officer which he dare not disobey, presents a matter of urgency, and it is within the discretion of the federal courts to at once take cognizance of the case, and act at once, rather than allow the case to be carried through three courts, taking two or three years of time. *Ex parte Royall*, 117 U. S. 241, 6 Sup. Ct. 734, 29 L. Ed. 868; *Campbell v. Waite*, 31 C. C. A. 403, 88 Fed. 102, by the court of appeals for this circuit. Therefore it follows that the habeas corpus proceedings are the proper remedy in a case like the one at bar. The question here involved has many times been decided in all its material phases, and, in my judgment, is not open to serious question. *In re Waite* (D. C.) 81 Fed. 359, decided by Judge Shiras, in the Northern district of Iowa, in 1897. *Waite* held a commission under the commissioner of pensions. It was his duty to take evidence and examine into claims of fraud pertaining to pensions. While in the performance of that duty, and thus taking evidence of a witness, the witness afterwards charged that *Waite*, the pension examiner, maliciously threatened him to compel him to do an

act against his will, which under the Iowa statute is an indictable offense, and Waite was indicted in the state court for the alleged offense. On his trial he urged that in doing the things complained of he was in the performance of an official duty as a United States officer. But he was convicted, and appealed to the Iowa supreme court; and that court decided that his contention was without merit, and affirmed the judgment. *State v. Waite*, 70 N. W. 596. Thereupon Waite applied for and obtained a writ of habeas corpus from Judge Shiras, and upon hearing was discharged, in the face of the judgment of the district court of Howard county, Iowa, and of the supreme court of the state; and, after a careful reading and study of the opinion of Judge Shiras, I find that there is little remaining to be said, because I fully indorse it as being full and complete, and one that cannot be successfully answered. All the then existing authorities are presented, and I need only cite that opinion as being expressive of my views. For if I were to attempt to elaborate upon the question I would only engage in repetition which cannot possibly serve a useful purpose.

But that is not all. The judgment of Judge Shiras was affirmed without dissent by the United States circuit court of appeals for this circuit, which affirmance is reported in 31 C. C. A. 403, 88 Fed. 102. But that is not all. The opinion of Judge Shiras is cited with approval by the supreme court of the United States in the case of *Ohio v. Thomas*, 173 U. S. 276-284, 19 Sup. Ct. 453, 43 L. Ed. 699. So that the holding of Judge Shiras, by the affirmance thereof by the court of appeals, is the law of this circuit, and the supreme court has said that it is the law of the nation. Not only has that court said so once, but many times, as will be seen by referring to the cases above cited.

And why should this not be so? It is begging the whole question, and it is idle, to say that any and all federal officers are amenable and subject to the laws, civil and criminal, of Iowa when within the state. Of course they are. The secretary of war, the general of the armies, the chief justice, and even the president, perhaps, are subject to all the laws of Iowa, when in Iowa. No one disputes this. But that is not the question. Can any one of those officers, or any subordinate, in the discharge of his duties as a government officer, be subject to the laws of the state while in the state? That is the question and the only question. The state is not greater than the nation; but, on the contrary, the state is but a part, and a small part, of the nation. And, if I am wrong, then instead of the president, and the secretary of war, and the general of the army being in control, we will have army commands given by and through the courts, and an officer like Major Turner cashiered and dismissed from the service if he refuses to obey the commands from his superiors, and if he does obey them thrown into a county jail for contempt of court.

A much stronger showing for the exercise of jurisdiction by a state court was presented in the case of *In re Neagle*, 135 U. S. 1, 10 Sup. Ct. 658, 34 L. Ed. 55. In that case Neagle was acting under directions of the attorney general, in acting as an escort to a United States judge in going from one court to another, and in protecting the judge from the infuriated and defeated attorney of his court in litigation recently before the judge; and, in protecting the judge, Neagle, the attendant,

killed the assailant. The California courts undertook to hold and try him for murder. But he was taken from the control and custody of the California courts by a United States court, and on habeas corpus proceedings discharged. And in *Ohio v. Thomas*, 173 U. S. 276, 19 Sup. Ct. 453, 43 L. Ed. 699, a like holding was made.

So that, both by reason and the highest authority of the land, I hold that an officer of the United States army, in the discharge of his duty, acting in obedience to commands by the secretary of war, who in turn is executing an act of congress, is not subject to arrest on a warrant or order of a state court, and that such arrest is wholly illegal; and it follows that Major Turner is discharged from custody and detention.

Next, as to the injunction case in the circuit court. It is claimed that the amount in controversy does not exceed \$2,000. But it is the value of the land, and not of the use, that is decisive of this question. That there is a federal question involved cannot be in doubt. It appears from the face of the petition, filed in the state court, that defendants were executing an act of congress, and complainant says, in effect and meaning, that the statute is being executed in an unauthorized and unlawful manner, because of that provision of the constitution which declares, "nor shall private property be taken for public use without just compensation." Const. Amend. art. 5. So that in this case we have not only a federal statute involved, under which defendants are acting, but we have a provision of the federal constitution which defendants are charged by plaintiff, the landowner, with violating; and this all because, not that defendants are taking plaintiff's property for the government, but that by laying the sewer they are depreciating the value of his property. And whether this is a taking within the meaning of the constitution I make no ruling. That question is not yet reached. But complainant asserts the proposition, and defendants deny it. Surely we have a federal question. But that cannot be tried on injunction issued by a state court.

The injunction was improvidently issued, and should be set aside, and the order is accordingly made; and, regardless of the citizenship of the parties, a federal question being involved, and the amount in controversy being sufficient, the case was properly removed to this court by order of the state court, and the motion to remand is overruled.

The United States attorney asks that the case be dismissed because the state court was without jurisdiction. But that question was not argued and is not considered by me. The case will stand for such further action as counsel may be advised to take.

If complainant will suffer a legal wrong, he will have a legal remedy. Perhaps when the sewer is constructed the complainant will then see that his wrongs have been imaginary. But, if his wrongs shall prove to be real, our government will see to it, either that he has a remedy in the proper court, or that his wrongs are righted by being given the amplest redress. At all events, he cannot control the army by writ of injunction, as great and powerful and beneficent as that writ is.

UNITED STATES, to Use of SALEM-BEDFORD STONE CO., v.
SHERIDAN et al.

(Circuit Court, W. D. Kentucky. March 17, 1902.)

1. FEDERAL COURTS—ACTION ON BOND OF GOVERNMENT CONTRACTOR—NONRESIDENT SURETY.

In view of the provisions of Act Aug. 13, 1894 (28 Stat. 279 [U. S. Comp. St. 1901, p. 2315]), which requires surety companies before they can be accepted as surety on a bond given to the United States by a contractor for government work to file a power of attorney and consent to certain conditions as to service of process and entry of appearance in the district where the bond is given, a petition against such a company as surety on a contractor's bond in the district where it was given, where service appears to have been made on its authorized agent, is not demurrable on the ground that it is not an inhabitant of the district.

2. SAME—JURISDICTION—UNITED STATES AS NOMINAL PLAINTIFF.

Under Act Aug. 13, 1894 (28 Stat. 279 [U. S. Comp. St. 1901, p. 2315]), which requires contractors for government work to give bonds conditioned for the prompt payment of all persons supplying labor or materials in the prosecution of the work, and authorizing such persons in case of non-payment "to bring suit in the name of the United States for his or their use and benefit against said contractor and sureties," such a suit is not one brought by the United States as plaintiff, within the meaning of the judiciary act, so as to give a federal court jurisdiction, without regard to the citizenship of the parties or the amount involved, since the United States is merely a formal party, without interest, and to confer jurisdiction on a federal court there must be diversity of citizenship, and also an amount involved exceeding \$2,000, exclusive of interest and costs.

At Law. On demurrer to petition.

Gibson, Marshall & Gibson, for the United States.

St. John Boyle, for defendant Fidelity & Deposit Co. of Maryland.

EVANS, District Judge. The United States, for the purpose of making certain public improvements at lock No. 8, on the Kentucky river, entered into a contract with the defendant Thomas A. Sheridan, who agreed to construct the same. Previous to the beginning of the work Sheridan was required to execute, and did execute, a bond to the United States conditioned according to the requirements of the act "for the protection of persons furnishing materials and labor for the construction of public works," approved August 13, 1894 (28 Stat. 278 [U. S. Comp. St. 1901, p. 2523]), which bond was dated August 30, 1898, and having thereon as surety the Fidelity & Deposit Company of Maryland. The Salem-Bedford Stone Company supplied certain material and labor to Sheridan in the construction of the work, and for the materials, etc., thus supplied, the contractor paid the Salem-Bedford Stone Company all except a balance of \$1,829.28, which became due early in the year 1900. The plaintiffs, calculating and manifestly including the interest on that balance, and possibly earlier balances, up to the time of instituting this action, sued the defendants jointly for the sum of \$2,153.41. Sheridan has not been served with process, but process was executed upon Willis S. Mullen, the agent of the corporation defendant in this district, by the marshal of this court. Under these circumstances the corporation defendant has filed a demurrer to the petition. By the first ground it is insisted that as it appears

upon the face of the petition that the surety is a Maryland corporation, and not an inhabitant of Kentucky, jurisdiction of its person cannot be obtained in this district. We think, however, in view of the nature of the obligation sued on, which was executed in the district of Kentucky, and which is dated August 30, 1898, and in view of the character and nature of the defendant surety itself, the court, in passing upon this ground of demurrer, must look to and must consider, as part of the law of the case, the provisions of the act of August 13, 1894 (chapter 282, 28 Stat. 279 [U. S. Comp. St. 1901, p. 2315]), because the operation of those provisions may give a right to sue the corporation here, although it is not an "inhabitant" of this district, in this respect modifying the provisions of the judiciary act. The act of 1894 requires that, before such a company as the corporation defendant shall be accepted as surety on bonds given to the United States, it shall be approved, and shall file a certain power of attorney, and shall consent to certain conditions as to service of process and entry of appearance in any district where a bond is given upon which it is surety. In view of all these provisions of the laws of the United States, we conclude that the proper way to test the question of the jurisdiction of the court over the person of the surety on such a bond, where there appears to have been service upon its authorized agent, is not by a demurrer, but by a special plea to the jurisdiction, or by a motion to quash the service of the summons, or by some other step by which the issue can be raised as to whether such jurisdiction has been acquired by such service of process on defendant's agent as might appear from the marshal's return thereof to have been made, notwithstanding such defendant is not an inhabitant of the district. See *Shainwald v. Davids* (D. C.) 69 Fed. 704. In view of the congressional legislation referred to, and which seems to modify the judiciary act so as to permit suits in certain cases against a defendant who is not an inhabitant of the district, the demurrer does not reach the objection thus sought to be raised, and it is therefore overruled.

2. A second ground of demurrer is that the court is without jurisdiction of the action because the amount in controversy does not exceed \$2,000, exclusive of interest and costs, and this raises a more difficult question, and one about which the court is not altogether free from doubt. If the court's jurisdiction in case of the requisite diverse citizenship does not reach such a case where the amount involved is less than \$2,000, exclusive of interest and costs, then, upon the most familiar authorities, that objection cannot be evaded by adding interest to principal, nor by overstating what is otherwise shown to be the amount of principal due, in order to make the sum exceed \$2,000. *Moore v. Town of Edgefield* (C. C.) 32 Fed. 498; *Brown v. Webster*, 156 U. S. 328, 15 Sup. Ct. 377, 39 L. Ed. 440. By the provisions of section 629, cl. 3, Rev. St. U. S. [U. S. Comp. St. 1901, p. 503], the circuit courts of the United States were given jurisdiction over suits at common law where the United States or any officer suing under the authority of an act of congress are plaintiffs, precisely as the district courts were given similar jurisdiction under the third clause of section 563 [U. S. Comp. St. 1901, p. 456]. Under these provisions, if the United States sued as a plaintiff the amount involved was of no im-

portance, inasmuch as the jurisdiction of the court, where the United States sued as a plaintiff, was not made in any way to depend upon the amount in controversy in common-law actions. By the first section of the judiciary act of March 3, 1887 (24 Stat. 552, corrected by the act of August 13, 1888, 25 Stat. 433 [U. S. Comp. St. 1901, p. 514]), very material changes were made in the laws regulating the jurisdiction of the federal courts; but, as distinctly held in the case of *U. S. v. Sayward*, 160 U. S. 493, 16 Sup. Ct. 371, 40 L. Ed. 508, these provisions did not so change the law regulating the jurisdiction of federal courts in common-law cases, where the United States sued as plaintiff, as in any wise to make that jurisdiction depend upon the amount in controversy. In this case the name of the United States is used as a plaintiff, but is so used expressly for the benefit of the Salem-Bedford Stone Company alone. The right thus to sue is claimed under the provisions of the act of August 13, 1894 [U. S. Comp. St. 1901, p. 2315], entitled "An act for the protection of persons furnishing materials and labor for the construction of public works," and which is in this language:

"Be it enacted by the senate and house of representatives of the United States of America in congress assembled, that hereafter any person or persons entering into a formal contract with the United States for the construction of any public building, or the prosecution and completion of any public work or for repairs, upon any public building or public work, shall be required before commencing such work to execute the usual penal bond, with good and sufficient sureties, with the additional obligations that such contractor or contractors shall promptly make payments to all persons supplying him or them labor and materials in the prosecution of the work provided for in such contract; and any person or persons making application therefor, and furnishing affidavit to the department under the direction of which said work is being, or has been, prosecuted, that labor or materials for the prosecution of such work has been supplied by him or them, and payment for which has not been made, shall be furnished with a certified copy of said contract and bond, upon which said person or persons supplying such labor and materials shall have a right of action, and shall be authorized to bring suit in the name of the United States for his or their use and benefit against said contractor and sureties and to prosecute the same to final judgment, and execution: provided, that such action and its prosecutions shall involve the United States in no expense.

"Sec. 2. Provided that in such case the court in which such action is brought is authorized to require proper security for costs in case judgment is for the defendant.

"Approved August 13, 1894."

While the petition shows that this action is literally brought in the name of the "United States as plaintiff," is this true in the sense of that phrase as used in the judiciary acts? Does the United States in fact "sue" at all in the proper and actual sense of that word? Is the United States an actor in the pending litigation? Could the United States in any wise control it? Does not the United States merely permit the use of its name for the benefit of another, and is not the only connection of the government with the case merely passive and formal? The answer to all of these questions should probably depend upon the test of whether the United States is actually a party in interest in the litigation, or is merely a formal party under the permission of an act of congress, in order that there may not be a technical "variance" growing out of the fact that the bond sued upon is made

to the United States alone as the party of the first part, the Salem-Bedford Stone Company not being named in it. While time out of mind the official bonds of public officers and executors, administrators, guardians, and the like have been executed to the state or the commonwealth, still any individual aggrieved by any wrongful act of such officer or personal representative could, without the permission of the state, sue upon the bonds, though, for technical reasons now well-nigh obsolete, such person must use the name of the state ex relatione. But neither the United States in the one case nor the state in the other could recover in its own name for any wrong done to a mere individual, because it would itself have no cause of action. It is true that the act of August 13, 1894 [U. S. Comp. St. 1901, p. 2523], was enacted for beneficial purposes, and possibly those benefits to a certain extent may extend to the United States in making more certain and prompt the obtaining of materials and labor by contractors upon public works who have given the bond with surety upon which outside parties can rely; but it is apparent that those benefits to the United States are quite incidental, if not speculative. The real purpose of the legislation was obviously to provide a guaranty of payment to laborers and materialmen through the medium of the bond required, inasmuch as they could not, without permission of the government, acquire any lien upon works of public improvement; and while the United States so far takes care of the interests of those persons as to include in the bond a clause for their protection, instead of allowing them a lien, still the bond is made payable to the United States, and the United States might, of course, in its own name sue upon it to enforce its own rights and the duties of the contractor to it, and of any such suit this court would clearly have jurisdiction, regardless of the amount involved, because then the United States would be the real plaintiff,—the real party in interest. But can it be maintained that congress, by permitting private litigants, under certain circumstances stated in the act, to use the name of the United States in their suits on the bond, intended thereby also to enlarge the jurisdiction of the federal courts by providing that the use of the name of the United States by such litigant should mean that such cases were to be included among those of which federal courts were given jurisdiction, upon the ground that the "United States sued as plaintiff" within the meaning of the judiciary act, when in fact the United States did not, in any essential sense, sue at all, and had no kind of legal interest in the claim asserted by the real party, to wit, the materialman. It seems to me not. In the case of *U. S. v. Henderlong* (C. C.) 102 Fed. 2, the jurisdiction of the federal courts of such a case when the amount sued for is less than \$2,000 was expressly denied upon reasoning which seems to be sound, and the result would be the same whatever might be the amount of the demand, in the absence of diverse citizenship. It cannot be doubted that the corporation plaintiff in this case might use the name of the United States for its own use and benefit in any litigation in a state court, for it would have the express permission of congress for so doing under the conditions named in the act; but the question to be decided on this ground of demurrer is one of juris-

dictional amount, and it seems to me that, when we properly construe the laws of the United States bearing upon that question, it will be found that, in order to maintain the jurisdiction in this court in a case like this, the amount claimed should exceed the sum of \$2,000, besides interest and costs.

The Salem-Bedford Stone Company is alleged to be a citizen of Kentucky, and the defendant the Fidelity & Deposit Company is alleged to be a citizen of Maryland. This gives the diverse citizenship required, if, as we suppose is true from what has been stated, the defendant under the act of August 13, 1894 [U. S. Comp. St. 1901, p. 2523], referred to, is suable in this district, although not an inhabitant thereof. This diverse citizenship alone would give the court jurisdiction, if the plaintiff's demand exceeded, exclusive of interest and costs, the sum of \$2,000, though, as we have seen, this result could not in any way be influenced by the fact that the Salem-Bedford Stone Company, in suing upon its demand, had used the name of the United States as a formal plaintiff, suing for its use and benefit.

It may be proper to add that the privilege, under the judiciary act, of being sued only in that state of which it is an inhabitant, is personal, and may be waived. It doubtless was waived by the corporation defendant in this instance, if it, in order to be qualified to become surety on the bond sued on, complied with the act of 1894. See, also, *Empire Min. Co. v. Propeller Tow-Boat Co.* (C. C.) 108 Fed. 900; *Whitworth v. Railroad Co.* (C. C.) 107 Fed. 557, and cases cited.

Inasmuch as the demand in this case is for less than \$2,000 when the interest is excluded, the demurrer to the petition must be sustained for want of jurisdiction of the action.

UNITED STATES v. ADAMS EXP. CO.

(District Court, S. D. Iowa, E. D. December 22, 1902.)

No. 5,024.

1. CRIMINAL LAW—BILL OF PARTICULARS—EVIDENCE.

On prosecution for crime the court will limit the government in its evidence to those facts set forth in the bill of particulars.

2. INDICTMENT—DEMURRER—BILL OF PARTICULARS.

Where a demurrer goes both to the indictment and the bill of particulars, and is so treated by counsel on both sides, the court may so consider it to avoid a useless trial of the indictment, though the law does not require it to do so.

3. INTOXICATING LIQUORS—SALE WITHOUT LICENSE—COMMON CARRIER—INTERSTATE SHIPMENT.

On an indictment charging a common carrier with carrying on the business of a retail liquor dealer without a license by receiving liquors from a liquor company without the state, carrying them to the consignee C. O. D., receiving the money, and carrying it to the liquor company, it was immaterial that no bills or invoices accompanied the shipment.

4. SAME—INTERSTATE COMMERCE.

The "commerce clause" of the constitution was not involved, the only question being whether defendant sold the liquors.

5. SAME—TITLE—CONSIGNOR—CARRIER.

The title to the liquors passed to the consignee on delivery thereof by the liquor company to the carrier, and therefore the carrier acted as the vendee in carrying and agent of the vendor in collecting, and was not guilty of a sale.

6. COURTS—PRIOR DECISIONS.

The district court may decline to follow the weight of authority in the United States courts, the pertinent question being as to the rulings of the supreme court or the court of appeals for that circuit.

Lewis Miles, U. S. Atty., and George B. Stewart, Asst. U. S. Atty.-James C. Davis, for defendant.

McPHERSON, District Judge. This case is by indictment, charging the defendant as a joint-stock association (with the stockholders being unknown), within this district "carrying on the business of a retail liquor dealer without having paid the special tax as required by law." On motion of defendant the government was required to and has filed a bill of particulars. This bill is lengthy, but the substance is as follows: The defendant is a common carrier of goods, parcels, and merchandise, doing business as such in Iowa, Illinois, and other states, and the Dallas Transportation Company is a dealer in spirituous and other liquors at Dallas, Ill., and so known to be by defendant. That at the dates covered by the indictment the Dallas Company delivered at Dallas, Ill., to the defendant, for carriage and delivery at Birmingham, Iowa, jugs containing each less than five wine gallons of such liquors, addressed and consigned to certain and divers parties at said Iowa town, orders therefor for said liquors having been received by and for said Dallas Company from its agent, who took said orders from the consignees. All of said consignments were shipped C. O. D.; that is, the defendant carried said liquors from Dallas, Ill., to Birmingham, Iowa, and was to and did collect from the consignee the carrying charges and the selling price or value of the liquors, and, after collecting the two sums, was to and did deliver the liquors to the consignee. Neither the Dallas Company nor the defendant has paid the special tax as a retail liquor dealer at Birmingham, Iowa. When the price of the liquor was thus collected from the consignee by the defendant, it (the defendant) carried the money to Dallas, Ill., and turned it over to the Dallas Company, thereby completing the transaction. There were no bills nor invoices accompanying said liquors, and none delivered to the consignees. To this indictment, with the bill of particulars, defendant has demurred on the ground that the facts charged do not show the defendant to have carried on the business of a liquor dealer.

Whether a bill of particulars is a matter of record or part of the indictment, and whether, with the indictment, it is subject to demurrer, are all probably to be answered in the negative. Whether such a bill shall be ordered seems to be discretionary with the court. It can be amended; while an indictment, of course, cannot be amended. An indictment often is in such general terms, and yet sufficient in law, as to largely fail to apprise the defendant of what he must meet on the trial. And the office of a bill of particulars is to advise the court, but more particularly the defendant, of what facts, more or less in detail,

he will be required to meet. And the court will limit the government in its evidence to those facts set forth in the bill of particulars. In this case it was apparent from the general terms of the indictment, and the defendant being a corporation or joint-stock association, and from the crime charged, although the indictment was sufficient in law, that a bill of particulars ought to be filed; and, the demurrer going to both the indictment and the bill of particulars, and being so treated by counsel on both sides, the court will so regard it; because, if the facts so recited do not constitute a crime, there is no good purpose served in impaneling a jury and calling many witnesses from a distance, and then being compelled to direct a verdict for the defendant. Not because the law exacts it, but for the reasons stated, and none other, I will consider the case as if the indictment contained a recital of all the facts set forth in the bill of particulars.

The Dallas Company sells intoxicating liquors,—a fact known by defendant. The Dallas Company, through an agent in Iowa, takes orders from Iowa parties for liquors. The Dallas Company hands the liquors over to defendant in Illinois for two or more purposes, the one being to carry them to the consignee in Iowa. The defendant is to first carry them to a point on its own line in Iowa, where the consignee resides. Then, before turning them over to the consignee, it must collect from him the selling price. Then the consignee takes the liquors from defendant, and the defendant carries the money back to Illinois, and turns it over to the Dallas Company. Is the defendant thereby, in Iowa, engaged in the business of a liquor dealer? This court having no jurisdiction for crimes committed in Illinois, it is not material what was done in that state, excepting as such acts throw light on and are connected with the transactions within this district; and I fail to note the importance of the allegations that no bills nor invoices accompanied the shipment. And I likewise fail to appreciate any force in the argument of defendant's counsel that the "commerce clause" of the constitution in any way controls this case, and I need only state what the leading cases hold. *Leisey v. Hardin*, 135 U. S. 100, 10 Sup. Ct. 681, 34 L. Ed. 128, held a state statute as void which require the shipment of liquors in the original package to a point within the state from a point without the state, and which liquors must be accompanied with a certificate from the local authorities that the liquors were to be sold only for certain purposes other than for a beverage; and the statute was held to be void because of the "commerce clause." *Bowman v. Railroad Co.*, 125 U. S. 465, 8 Sup. Ct. 689, 31 L. Ed. 700, is in so far like the *Leisey Case* as that the only question was with reference to a state statute attempting to regulate and place conditions and burdens on commerce between the states. In *re Rahrer*, 140 U. S. 545, 11 Sup. Ct. 865, 35 L. Ed. 572, held that liquors brought from without to within the state should be within the provisions of the statute of the state because of a federal statute, and that such federal statute is a constitutional exercise of the power vested in congress. *Rhodes v. Iowa*, 170 U. S. 412, 18 Sup. Ct. 664, 42 L. Ed. 1088, held that the statute of the state, supplemented by the federal statute, making the state statute operative after the liquors once arrived within the state, could not apply to liquors in transit and before de-

livery to the consignee. These, and none of the other, cases under the "commerce clause," call for any review. Congress, and congress alone, has the power to regulate commerce between the states. When a state undertakes to regulate such commerce, however artful or disguised the form, such attempted regulation by the state is null and void. But while congress has the one power of regulating commerce between states, it also has another power of imposing an internal revenue tax on all agencies doing a business. And an agency, person, or corporation doing an interstate business can no more escape such internal revenue tax than can an agency, person, or corporation doing a business wholly within one state. There is nothing in the proposition. At least it is so plain to me that there is not that I do not care to pursue the question farther.

The only question, in my judgment, is, where and by whom were the liquors sold? If in Illinois, this court is without jurisdiction. If sold by the Dallas Company in Iowa, then the grand jury has made a mistake in naming a defendant in the indictment. Did the Adams Express Company carry on the business of a liquor dealer in Iowa? From the bill of particulars it is apparent that the principal business of the defendant is that of a common carrier, and as such it must receive, carry, and deliver to the consignee all merchandise offered to it by any and all persons within a reasonable time, for a reasonable compensation. It may exact the carrying charges in advance, or it may waive prepayment of such charges, in which event it has and retains a lien on such merchandise for the carrying charges, the payment of which by the consignee removes the lien. And it is within the knowledge of all men that such common carriers do a per cent. of their business by carrying goods, not only collecting its own carrying charges from consignees, but likewise collecting from the consignees the selling prices for the merchandise, and carrying such moneys back to the consignors. That is part of such carriers' business, and, generally speaking, it is lawful, and both stimulates and facilitates trade. And in all such cases, including the case at bar, the carrier has no interest nor profit in the transaction other than as carrier. It receives no percentage, nor share, nor profit from the sale of the liquor. The title to the liquors did not pass from the Dallas Company when the orders were taken by the agent. The company could ignore the orders, and refuse to ratify the act of the agent, for any reason, good or otherwise. Did the title pass from the Dallas Company to the consignees when the liquors, properly addressed, were deposited in the office of the defendant at Dallas, Ill., with directions to defendant to carry them to Iowa, and deliver them to the consignees, after first collecting the selling price? I believe, and so hold, that the title did then and there pass; and also hold that, the title thus passing, that it is decisive of this case against the government. That the authorities are in irreconcilable conflict is beyond question. But that the great weight of authority sustains the above holding is equally true. Indeed, counsel for the government concede this to be so as to the appellate state court decisions; and in making such concession they recognize the force of the many cases. The Iowa supreme court has many times so decided on this and kindred questions. *Brown v. Wieland* (Iowa) 89

N. W. 17, with cases cited by Judge McClain. In *State v. Hanaphy* (Iowa) 90 N. W. 601, in an opinion by Judge Weaver, it was held that the agent who took the order in Iowa did not make the sale. It is true that the Iowa court, in the recent case of *State v. Express Co.* (decided in October, 1902) 92 N. W. 66, seems to hold otherwise. But the opinion in that case is a per curiam opinion, and is grounded only on the prior decision of *State v. Express Co.*, 70 Iowa, 271, 30 N. W. 568. While the opinion in 70 Iowa, 271, 30 N. W. 568, was written by an eminent judge, yet it will be seen that the question is not elaborately discussed, and no attempt is made to support it by authority. And in the more recent case, above cited, the court says:

"A majority of the court, as now constituted, would be inclined to the view that under such a shipment the carrier is the agent of the buyer for the purpose of transportation, and of the seller for the purpose of retention of possession and collection of purchase price, and that, as a necessary corollary, title passed to the buyer on delivery to the carrier."

I quote this to show that the Iowa supreme court only decided the case as it did because of *stare decisis*, and to present a statement of that court, which seems to me to not only be correct, but one supported by the authorities. For the cases holding as I do, see the following: *Pilgren v. State*, 71 Ala. 368; *State v. Flanagan*, 38 W. Va. 53, 17 S. E. 792, 22 L. R. A. 430, 45 Am. St. Rep. 832; *Com. v. Fleming*, 130 Pa. 138, 18 Atl. 622, 5 L. R. A. 470, 17 Am. St. Rep. 763; *Higgins v. Murray*, 73 N. Y. 252; *State v. Peters*, 91 Me. 31, 39 Atl. 342; *Village of Coffeen v. Huber*, 78 Ill. App. 455; *Railroad Co. v. Barnes*, 104 N. C. 25, 10 S. E. 83, 5 L. R. A. 611; *State v. Carl*, 43 Ark. 353, 51 Am. Rep. 565; *Wheelous v. Parr*, 141 Mass. 593, 6 N. E. 787; *Benj. Sales* (1888 Ed.) p. 335. Also see the many cases cited in the above.

But counsel for the government contend that the weight of the cases in the United States courts is to the contrary. That might be so, and still I could well decline to follow them. The pertinent question is, has the supreme court or court of appeals for this circuit so held? *O'Niell v. Vermont*, 144 U. S. 323, 12 Sup. Ct. 693, 36 L. Ed. 450, is cited. That case is generally cited on matters of commerce, and it seems to be quite generally misunderstood. What was decided in that case, and all that was decided, was that that court was without jurisdiction. It was a writ of error to the supreme court of Vermont; and the supreme court was without jurisdiction because, only, that, as appeared from the record, a federal question was not presented to the Vermont trial court. On that question the case is an authority, and on no other question. The same case, as reported in 58 Vt. 140, 2 Atl. 586, 56 Am. Rep. 557, is in line with the contention of counsel for the government. That *Austin v. Tennessee*, 179 U. S. 387, 21 Sup. Ct. 132, 45 L. Ed. 224, is not in point need only be stated. What that court decided was that certain packages of cigarettes were subject to the police power of the state as expressed by legislation.

I can serve no purpose, either to the parties or to counsel in this case, by reviewing the cases cited in the brief in this case, but I will briefly refer to some of them. One case holds that the consignee cannot maintain *replevin* for the goods as against the carrier until he

pays the C. O. D. and the collection charges. Other cases hold that, if the sale of goods is on condition, the vendor can retake the property if the condition is not performed. Other cases hold that, if the consignee by fraud gets possession, the vendor can retake them. All of such cases are in harmony with, and some of them so hold, that the consignor does not retain the title, but does retain a lien until the goods are paid for. But such cases are not in point. *Stevens v. Ohio* (C. C.) 93 Fed. 793, is of no value in this case, for the reason that the consignor in West Virginia shipped the liquors to the agent of the consignor in Ohio, who then carried them personally to the consignee. The case of *U. S. v. Chevalier*, 107 Fed. 434, 46 C. C. A. 402, is relied on. There the defendant kept his principal place of business in California. He had a branch house in Oregon, with his name over the door, managed by an agent. The branch house took orders for liquors, and sent the orders to the main office in California, and from there the liquors were sent by a carrier to the purchasers in Oregon. The defendant had paid his government tax in California. Held, that he was not liable for the tax in Oregon. So that case in no wise sustains the contention of the government in the case at bar. The opinion does recite:

"A different case would have been presented if it had been shown that, instead of sending goods to the purchasers by a common carrier, the freight to be paid by the purchasers, the vendor had paid the freight charges, or had sent the goods by express, to be paid for on delivery from the express company; or had consigned them to his agent, to be by him delivered to the purchasers."

And cases are cited. But it also was said in the opinion:

"The current of authority is that, even in a case where the sale is made by the owner of the goods in person at a place other than that in which the goods are situated, the sale is not completed until the property is actually separated from the stock in the store, and delivered to the carrier, and that the place of such delivery is the place of sale."

That the case of *U. S. v. Shriver* (D. C.) 23 Fed. 134, by the district judge of the Southern district of Illinois, sustains the government, is conceded. But that the weight of authority, both state and federal, is to the effect that the title passes to the consignee when the goods are delivered to the carrier, I have no doubt. And that the fact that the goods are carried C. O. D. does not change the rule I am equally clear. And, this being so, the liquors in question were sold in Dallas, Ill.; and, the sales having been made there, there is no pretense that the liquors in question were again sold by any one.

The express company was the agent of the vendees in carrying the liquors, and the agent of the vendors in collecting and returning the money; and, as the express company did not sell the liquors, it was not engaged in the business of a liquor dealer.

In re HARE.

(District Court, N. D. New York. December 26, 1902.)

No. 1,018.

1. BANKRUPTCY—TRUSTEE—APPOINTMENT—DISAPPROVAL OF REFEREE.

Bankr. Act, c. 5, § 44 [U. S. Comp. St. 1901, p. 3438], provides that the creditors of a bankrupt estate shall at their first meeting after the adjudication, or after a vacancy has occurred in the office of trustee, appoint a trustee, and if they do not the court shall do so. General Order 13 (32 C. C. A. xvii, 89 Fed. vii) makes the appointment by the creditors subject to the approval of the referee or judge, but enacts that he shall be removable by the judge only. By Bankr. Act, § 1, subd. 16 [U. S. Comp. St. 1901, p. 3419], the term "judge" does not include "referee." *Held*, that a referee could not ignore the appointment of a trustee by creditors, and appoint another, but, if he disapproved, it was his duty to make an order in writing, and on this the parties had a right to be heard before the judge.

2. SAME—POWER OF REFEREE.

It is further provided by Bankr. Act, § 2, subd. 17 [U. S. Comp. St. 1901, p. 3421], that courts of bankruptcy have power, pursuant to the recommendation of creditors, or when they neglect to recommend the appointment of trustees, to appoint trustees, and upon complaints of creditors remove trustees for cause on hearing and after notice to them. *Held*, that this conferred no power to disregard the recommendation of creditors, and did not authorize the act of the referee.

3. SAME.

Assuming that there is a vacancy in the office of trustee on account of the disapproval of the referee, the court or referee could appoint another only after failure by the creditors to appoint after a full opportunity.

This is an appeal from an order of a referee in bankruptcy appointing one Eugene M. Perry trustee of the estate of the bankrupt, William A. Hare.

William A. Hare having been adjudged a bankrupt herein, the matter was duly referred to a referee for further proceedings under and pursuant to the provisions of the bankrupt act [U. S. Comp. St. 1901, p. 3418]. The first meeting of creditors was held May 19, 1902. The bankrupt appeared in person and by M. H. Kiley, his attorney. Geo. E. Dennison appeared for 18 creditors of said bankrupt, whose aggregated proved claims amounted to \$1,189.50. Other claims of other creditors, amounting in all to \$1,285.32, were filed, but these creditors were not represented by attorney, nor did they, or any of them, appear in person or vote for trustee. Said Dennison filed powers of attorney in due form, executed by the creditors represented by him, authorizing him to vote for a trustee. Several creditors residing in and about Georgetown, N. Y., filed requests that one Eugene Perry be appointed trustee. The bankrupt drew one of these requests. At the proper time Mr. Dennison, representing said creditors, and by virtue of said power of attorney, voted for one F. E. Richardson as trustee, and, no vote being cast for any other person, Mr. Richardson was duly elected or chosen trustee herein. The bankrupt and Perry resided at Georgetown, while Richardson resided at Cazenovia, 15 miles from Georgetown, at which place the property of the bankrupt, a small stock of goods usual to a country store, was located. The return of the referee, giving the proceedings subsequent to the appointment by creditors, says: "I held the question as to who should be appointed trustee open until after the recess for dinner, and during such recess the bankrupt reported to me that the said William B. Crouse had proposed to him that, in case he could obtain the appointment of his man for trustee, he would purchase the goods for as low a price as possible, and turn them over to any person the bankrupt might request at the price he paid, provided the demand of C. B. Crouse & Co. be paid in full. Mr. Richardson, as appeared, was a large customer of C.

B. Crouse & Co. The proofs of debt filed by Mr. Dennison were six of them from Utica, seven were from Syracuse, two from Earlville, one from Philadelphia, one from the city of Oneida, and one from Fairport, Monroe county, N. Y. That the twelve proofs of debt filed by said Dennison outside of Utica, or the power of attorney, are partially in the handwriting of said Dennison, and bear on their face conclusive evidence that said power of attorney was solicited by Dennison, and blanks forwarded by him therefor. On assembling after recess, I informed said Dennison that I would not appoint as trustee the person for whom he had voted. That he was a customer of said Crouse & Co. That he lived fifteen miles away from the estate of the bankrupt. That I had become fully satisfied that it was not for the interests of the creditors outside of said Crouse & Co. that such appointment should be made. I further suggested there were many good men in and about the village of Georgetown, and I would appoint any fair man in that community whom he might suggest. Said Dennison insisted that he would have no other man than Mr. Richardson. I therefore appointed as such trustee Mr. Eugene M. Perry, a reputable citizen of Georgetown, who has filed his bond, which I have approved and filed with the clerk." It thus appears that the referee ignored the appointment made by the creditors, and, without holding another election, proceeded to appoint Mr. Perry, favored by the bankrupt and some of the creditors,—how many does not appear. The statement quoted and reported to the referee by the bankrupt to have been made to him by Crouse is flatly contradicted by the affidavit of Mr. Crouse. The referee made no inquiry in court, or outside, so far as appears, into that alleged transaction, but seems to have accepted the ex parte statement of the bankrupt. Nothing against the character, standing, ability, or integrity of Mr. Richardson is shown. The referee states, as quoted, "Mr. Richardson, as appeared, was a large customer of C. B. Crouse & Co."

Geo. E. Dennison, for appellants.

M. H. Kiley, for Perry, trustee.

RAY, District Judge (after stating the facts). It is plain that the order appointing Eugene F. Perry trustee of the property of this bankrupt cannot be sustained and should not be sustained. Chapter 5 of the bankruptcy act [U. S. Comp. St. 1901, p. 3434] is devoted to "Officers, Their Duties and Compensation." Section 44 [U. S. Comp. St. 1901, p. 3438] reads as follows:

"Appointment of Trustees. (a) The creditors of a bankrupt estate shall, at their first meeting after the adjudication or after a vacancy has occurred in the office of trustee, or after an estate has been reopened, or after a composition has been set aside or a discharge revoked, or if there is a vacancy in the office of trustee, appoint one trustee or three trustees of such estate. If the creditors do not appoint a trustee or trustees as herein provided, the court shall do so."

This is plain, unequivocal, and imperative. The creditors at their first meeting (in the case at bar) were to appoint the trustee. This they proceeded to do. The creditors having appointed a trustee, there was nothing for the referee to do in that regard except approve or disapprove such appointment.

General Order 13 (32 C. C. A. xvii, 89 Fed. vii) says:

"The appointment of a trustee by the creditors shall be subject to be approved or disapproved by the referee or by the judge; and he shall be removable by the judge only."

"Judge" does not include the referee. Section 1, subd. 16 [U. S. Comp. St. 1901, p. 3419].

It is plain that, the appointment by the creditors having been actually made, the referee was called upon to approve or disapprove the ap-

pointment. This he could not do by mental action or words alone. It was his duty to make an order in writing disapproving the appointment, if he disapproved, and on this the parties had a right to be heard before the judge, as "he [the trustee] shall be removable by the judge only." This general order confers no power on a referee to announce, as was done in this case, that he will not appoint the trustee already appointed by the creditors. It does authorize him to disapprove such appointment by order, and should this be done at the time the appointment is made by the creditors it is probable that the creditors might proceed at once to appoint some other person, as this would be an acquiescence in such disapproval; but should they not do this the matter should be reported to the judge, who may remove the trustee appointed by the creditors, and order another appointment by the creditors. In no event can the referee ignore the appointment made by the creditors, and proceed summarily to appoint the trustee without holding another election, as was done in this case. He cannot compel the creditors to vote, but he can give them an opportunity. If they do not vote, they have neglected to appoint or recommend.

Chapter 2 of the bankruptcy act [U. S. Comp. St. 1901, p. 3420] creating the courts of bankruptcy, and defining their jurisdiction, being section 2 of said act, provides (subdivision 17) that courts of bankruptcy have power to, "pursuant to the recommendation of creditors, or when they neglect to recommend the appointment of trustees, appoint trustees, and, upon complaints of creditors, remove trustees for cause upon hearings and after notices to them." This confers no power to disregard the recommendation of the creditors. Nor have they failed to recommend when they have, so far as voting at all, unanimously appointed a trustee, and the referee disapproves such action. The referee cannot control the action of the creditors in any such arbitrary manner. The law places, and was intended to place, the appointment of the trustee in the hands of the creditors, subject to the power of the judge to remove the person so appointed in case the referee disapproves, or for cause shown on application by other interested persons. This is a plain and a sensible construction of the act and general order, taken together. There is no failure to appoint when the referee disapproves the appointment. The trustee is appointed, and may be removed by the judge on the disapproval of the referee.

But, even if we assume that there is a vacancy in the office of trustee where the creditors appoint and the referee disapproves (which this court denies, but see *In re Lewensohn* [D. C.] 98 Fed. 576), the act itself is plain and explicit that the creditors shall make the appointment to fill the vacancy. It is only when the creditors fail or neglect, after full and fair opportunity, to appoint a trustee that the court or referee may step in and make an appointment. The return of the referee states that "said Dennison insisted that he would have no other man than Mr. Richardson." This, if true, was no justification for the appointment made by the referee. Even if the referee had power to make an appointment at that meeting, on the failure of the creditors to make an appointment that should meet his approval,—a proposition to which this court cannot assent,—this statement of Mr. Dennison

was not in execution of his power, nor did it constitute a failure by the creditors to appoint, and it is probable that had the referee taken another vote on the election of a trustee Mr. Dennison would have cast the votes represented by him for some one, perhaps some other person. In any event, that was the only proper and legal course to pursue, assuming the referee had the power to take any action other than report the appointment and disapproval to the judge.

It is unnecessary to comment on the insufficiency of the objections to Mr. Richardson. If he was not a proper person, because he resided 15 miles from the bankrupt stock and had dealings with one of the creditors, how forcible are the objections to Perry, who evidently was the choice of the bankrupt himself, and was not voted for by any creditor? Nor is it necessary to more than suggest the impropriety of conferences between the bankrupt and referee or creditors and the referee outside of court, and in the absence of other interested parties, as to the personality, fitness, etc., of the trustee appointed. The parties having objections to Mr. Richardson should have come into court, and there presented the objections which the referee states were made to him outside. Had this been done, the bankrupt could have been examined as to the truth of the charge made, and Mr. Crouse and other creditors would have had an opportunity to reply. Again, the seven creditors residing at Syracuse, the six residing at Utica, the two residing at Earlville, the one residing at Philadelphia, the one residing at Oneida, and the one residing at Fairport had equal rights with all others, and quite likely and quite properly they objected to a trustee suggested, it would seem, by the bankrupt, and residing in his town and village. In this case the interests and wishes of the creditors who took interest enough in the proceedings to avail themselves of the law made for the protection of creditors were improperly disregarded.

The order of the referee appointing Eugene M. Perry trustee of the bankrupt, William A. Hare, must be vacated and set aside, and an order to that effect will be entered.

POST v. BUCKLEY et al.

(Circuit Court, S. D. New York, October 3, 1902.)

1. JURISDICTION OF FEDERAL COURTS—DIVERSITY OF CITIZENSHIP—NOMINAL PARTIES.

A defendant who is substantially charged in the bill with conspiracy to defraud, and against whom a large judgment is asked on the ground that he refused to surrender on demand property which had been conveyed to him as trustee by complainant, but permitted the same to be sold under foreclosure, cannot be considered a merely nominal party, and the fact that he is a citizen of the same state as complainant deprives a federal court of jurisdiction.

In Equity. Argument on plea.

William Blaikie, for complainant.

John Brooks Leavitt, for defendants.

¶ 1. Diverse citizenship as ground of federal jurisdiction, see notes to *Shipp v. Williams*, 10 C. C. A. 249; *Mason v. Dullagham*, 27 C. C. A. 298.

TOWNSEND, Circuit Judge. The complaint alleges: that complainant is a citizen and an inhabitant of New York, and that the defendants are citizens and inhabitants of the state of New Jersey; an agreement between complainant and the defendant Charles that Charles should loan money to the complainant to buy real estate, and that, to secure defendant, 150 acres of land owned by complainant in Linden township, N. J., was transferred to William, the other defendant, as also the real estate purchased; that, as a bonus, complainant gave a note for \$3,000 to Charles, and for \$1,000 to William, which were afterwards returned, and acknowledgments for the same amounts for sums due for services substituted; that on January 4, 1894, Charles agreed to loan complainant \$10,000, or so much as he might require to pay interest upon the mortgages and taxes on said lands, until he could dispose of the whole or repay the loans, and that to secure said \$10,000, or so much as might be loaned, complainant conveyed two other farms, of 154 acres, to said William; that said 154 acres were then worth over \$150,000, and are now worth more than \$200,000, and were only incumbered for about \$10,200, and that, if said Charles had kept his agreement to loan money to complainant until complainant by sale could pay up the loans and incumbrances, the mortgages on the property could have been continued; that whenever Charles made loans he demanded and required bonus notes in addition to the amount loaned; that after January, 1894, 500 acres and upwards having been conveyed to William in trust as aforesaid, Charles refused to loan any more money unless complainant would give him a bonus of 100 per cent. on each of said loans; and that in June, 1894, complainant demanded from defendants a return of said 154 acres, and that later complainant notified defendants that he had a party ready to advance the money to pay interest and taxes, if he could secure him with said lands, and defendants refused to reconvey any part of them; that defendants were at all times able to carry out their agreements, and that by reason of their failure so to do, and to advance the money, 300 acres have been sold at forced sale, worth more than \$200,000, at a loss to complainant of over \$150,000; that on September 15, 1900, defendants returned to complainant all of his notes, except one for \$1,380, and reconveyed all of the land then held by said William, subject to three mortgages held by said Charles for \$5,000, and that thereupon complainant executed his bond for \$33,325 to the defendants, secured by a mortgage on the land so reconveyed, and that on the same day defendants gave consents for the discontinuance of three actions on their notes pending in the supreme court of New York, and for three other actions pending in chancery in New Jersey for foreclosure of mortgages on parts of said lands; that all transactions and dealings between complainant and defendants said to be released and satisfied by said agreement of September 15, 1900, were made while defendants were attorneys and counsel of complainant; that complainant only assented to said settlement of September 15, 1900, because he was unable in any other way to save even the remaining 250 acres, or any part thereof, and because defendants told him just before he signed the agreement that unless he did sign it they would let the

whole of said land go. Defendants file a plea alleging: First. That the defendant William at the time of the filing of the bill was, and long before had been, a citizen and resident of the state of New York. Second. That on September 15, 1900, there were pending actions at law and in equity between the parties in New York and New Jersey, in which all matters set forth in the complaint were in litigation, and could have been fully tried and determined; that it was agreed between the parties that they should settle the same out of court, and that an accounting was had, and settlement made, the complainant acting under the advice of his counsel, George T. Werts, whereby defendant William reconveyed the lands to complainant, and complainant executed his bond and mortgage for \$33,325. The agreement is set out in full, is witnessed by said George T. Werts, and includes a full satisfaction and discharge by the complainant of all and every claim and demand or cause of action, legal or equitable, arising or growing out of any agreements made or transactions had between him and the defendants, or either of them. The plea is not denied.

The first question is that of jurisdiction. Complainant claims that said William is a mere stakeholder, a nominal party, and that, although he may in fact reside in New York, there are only two real parties to the case, complainant and defendant Charles, and therefore the court has jurisdiction. Even if it be so that a defendant from whom a judgment for a conveyance was claimed could be considered as a nominal party, so as not to oust the jurisdiction of the court, it appears from the complaint that William has not now a large part of the real estate, the conveyance of which is demanded, but that it has been sold, apparently under foreclosure; and complainant claims judgment against him, that the agreement discharging him from all claims be declared void by reason of fraud, deception, and breach of fiduciary relations, menace and duress, practiced by defendants, and that the defendants, and each of them, be decreed to cause said 300 acres to be conveyed to complainant, or in lieu thereof to pay \$200,000. A defendant who is substantially charged with conspiracy to defraud and against whom it is purposed to obtain a judgment of \$200,000, on the ground that he did not surrender the property on demand, can hardly be considered a merely nominal defendant. It appears, also, from the whole complaint that William, also, has some claim for services on his part included in the bond for \$33,325 which complainant seeks to have declared void. It must be held that he is not a mere nominal defendant, and that the court has no jurisdiction.

Defendants urged upon the court that by reason of the charges made against them personally, and their position as attorneys, there should be a decision on the merits, as shown by the pleadings. If the court has no jurisdiction, such judgment could have no legal effect. But as the matter has been fully argued, and counsel for complainant united in the request for such decision, it may not be amiss to observe that, although the value of the real estate in question is alleged in hundreds of thousands of dollars, there is no allegation as to the amount actually invested by complainant, other than what might be

inferred from the statement that the 300 acres were purchased between April and July, 1892; that in said purchases said Charles furnished less money than the complainant; and that on February 1, 1893, it was found that the loans up to that time amounted to \$15,600. From the whole complaint it appears probable that the amount which could be actually realized by sale of these properties did not greatly exceed the mortgages. The only pressure brought upon complainant to make the settlement alleged to have been made was that the defendant Charles said unless he made a settlement they would let the whole property go, which indicates that mortgages were liable to be foreclosed, and that defendants did not purpose to advance money to redeem. Suits are admitted to have been pending in court in which the questions here raised might have been determined, and complainant, on advice of counsel, made a complete settlement. If the court had jurisdiction, it would not appear that there are any facts alleged which would justify the court in declaring the settlement void, thus depriving the defendants of the right, which at the time of settlement they had, to have the whole matter determined in the courts of New York and New Jersey.

SAWYER v. ATCHISON, T. & S. F. R. CO. et al.

(Circuit Court, S. D. New York. October 23, 1902.)

1. EQUITY JURISDICTION—ADEQUATE REMEDY AT LAW.

A bill against a railroad company, a reorganized company, which had purchased and obtained possession of the property of the first company through a foreclosure sale, and a trust company, to obtain possession of certain bonds deposited by complainant with the trust company on which the first railroad company was guarantor, and to enforce payment of the same by the railroad company, on the ground that the foreclosure sale was void, if not multifarious, states no case for equitable relief; it not appearing from the facts stated that there is not an adequate remedy at law.

In Equity. On demurrer to bill.

Ford & Tuttle, for complainant.

Opdyke, Willcox & Bristow and Butler, Notman, Joline & Mynderse, for defendants.

TOWNSEND, Circuit Judge. Demurrer to complaint. Defendants demur separately, on the ground that the complaint states no case for equitable relief, that there is adequate remedy at law, and of multifariousness and laches. The complaint is long, and is accompanied by many long exhibits. The principal allegations are as follows: Subsequent to August 27, 1895, complainant purchased 20 second-mortgage bonds of the Colorado Midland Railroad Company, guaranteed by the Atchison, Topeka & Santa Fé Railroad Company, on which interest had been in default for a year and a half; foreclosures being then pending on the first mortgage, as well as on the second mortgage, and a receiver having been appointed, the property of the Colorado Midland Company having previously passed into the possession of said Atchison Railroad Company. Foreclosures had also been

brought against the Atchison Railroad Company, and a decree of foreclosure had been made on August 27, 1895, but the property had not been absolutely sold. The complainant deposited his bonds with the defendant the Central Trust Company, with other holders of similar bonds, for the purpose of effectuating the reorganization of the Atchison Railroad Company by a bondholders' committee. Afterwards the property of the Colorado Midland Company was sold under foreclosure for a nominal amount, and said Colorado Midland Company is wholly insolvent, and has no property from which payment of the bonds can be secured. Under the laws of Kansas, property of a railroad company cannot be sold within three years after foreclosure without the request of a majority of the holders of the mortgage bonds. The sale of the property of the Atchison Railroad Company was made at the request of the reorganization committee, who are not the real or beneficial owners of the majority of the bonds, nor were the bonds in their actual custody; and said sale was, therefore, by the laws of Kansas, absolutely void. The plan of reorganization was not accepted by the bondholders within the time limited in the agreement under which the bonds were deposited, and when the meeting was held to accept the plan of reorganization complainant refused to be a party to it and demanded the return of his bonds; but the defendant the Central Trust Company refused to return the bonds, claiming that complainant was bound by the agreement under which they were deposited. On December 10, 1895, the assets of the Atchison Railroad Company were sold for a nominal price to the bondholders, and thereupon a new corporation, the defendant the Atchison, Topeka & Santa Fé Railway Company, was organized. New bonds were issued in place of the first-mortgage bonds, and preferred stock in place of others. Common stock of the new company was given to the stockholders of the defunct Atchison Railroad Company, but no provision was made for the bonds of the complainant, guaranteed by the old Atchison Company, and the assets of the Colorado Midland Railroad Company were sold under foreclosure for a small amount, whereby said bonds had become worthless unless they could be collected from the railway company. Since the reorganization the business of the Atchison Railway Company has been improving, and its profits have steadily increased, so that claims against it would now be valuable. Complainant prays for a judgment that he is the owner of said 20 second-mortgage bonds, and entitled to their possession, and that the defendant the Central Trust Company produce or account for them; that said bonds are a valid and existing obligation of the defendant the Atchison Railway Company; that as to him the pretended foreclosure of the Atchison Railroad Company and organization of the Atchison Railway Company was a nullity; that the sale and conveyance under the foreclosure was absolutely void; and that the common stock in the company be seized and sold by the court for the payment of complainant's bonds.

It is not clear what cause of action in equity complainant has against the defendant railway company or its stockholders. He knew of the foreclosure, and there is no allegation that he made any objection at the time to the confirmation by the court of the sales under fore-

closure. The transfers were legal on their face. It is several years since the transfer, and meanwhile the new company has operated the road and made it valuable. Complainant insists that he has no adequate remedy at law, because in a suit against the Central Trust Company in trover or replevin it would be necessary to show the frauds alleged in order to establish the value of the bonds. No reason appears why, if the sale of the assets of the Atchison Railroad Company was absolutely void under the Kansas statute, such fact and any other evidence tending to establish the value of the bonds cannot be produced in an action at law. There is apparently considerable foundation for defendants' contention that the complaint is multifarious. It seems desirable that the questions arising on the complaint should be first finally settled on appeal.

The demurrer is sustained.

DOBSON et al. v. PECK BROS. & CO. et al.

(Circuit Court, D. Connecticut. December 17, 1902.)

No. 1,036.

1. FEDERAL COURTS—JURISDICTION—RECEIVERSHIP—NEGLIGENT CREDITORS.

Where creditors of a corporation had notice of receivership proceedings in the state courts, and ample opportunity to prove their claim, a federal court will not interfere to protect their rights, even though their prayer has some equitable aspects.

In Equity.

William Hoag, for complainants.

White, Daggett & Tilson, for defendant Peck Bros. & Co.

PLATT, District Judge. This is a creditor's bill to reach property transferred to Peck Bros. & Co., defendant, and has been heard on final pleadings and proofs. Before the taking of proofs a plea was set down for argument by the complainants. It was a plea in bar, filed by the only existing defendant, setting up certain receivership proceedings, orders, and decrees in the New Haven county superior court of Connecticut, under which all claims against the old corporation had become forever barred, and the corporation itself dissolved. The opinion of Judge Shipman relating thereto appears in (C. C.) 103 Fed. 904. After a critical examination of that opinion, it would seem that the contention in this case had been concluded by the proofs which, as the outcome of the hearing, have been introduced since September 20, 1900. At that time the matter stood in this wise: The bill contained allegations that the receivership proceedings were a scheme of fraud and conspiracy upon the part of the stockholders of both corporations; and, further, that, since the complainants were nonresidents, and strangers to those proceedings, it was their right to show that they were collusive and fraudulent. The object of the bill was to overturn an alleged successful fraud and conspiracy carried out by decree of a court collusively obtained. These averments had been denied by the answer which accompanied the plea. The bill

anticipated the defense, and therefore it was wise that the plea should stand for an answer, and that the questions of conspiracy and fraud should be threshed out by proofs, before any finding as to the validity of the plea in bar could be satisfactorily made. Now the proofs are before this court, and they signally fail to support the contentions which the complainants must have urged so strenuously on the argument of the plea. Counsel for the complainants, with a refreshing frankness, almost admits this to be so in his brief. He now pins his hope, however, upon a line of argument somewhat as follows: The obligation of the old company under the lease still exists, and the new company has accepted a gift of the cash on hand when the receivership was closed, and is not a bona fide holder for value of the entire assets of the old corporation, having acquired them at a nominal value. It is not believed that such reasoning would have availed the complainants had the present situation existed when the plea was argued. The consideration for the acquisition of the property now in the hands of the new corporation is not a material question. Inasmuch as every creditor of the old corporation was either paid in full or had ample facilities furnished so that the payment could have been made, and the transfer of assets has been made in good faith, a court of equity is far more concerned about the rights of the stockholders of the new corporation than about the logic of a belated claimant. Complainants were notified of the receivership proceedings in Connecticut, and the ancillary steps in Massachusetts, and their opportunity to prove their claim in a competent court of equity was absolutely open to them in both jurisdictions. They debated the matter and preferred to take their chances that the old corporation was solvent, and would continue to occupy the leased premises. That decision was founded upon hopes, guesses, uncertainties, and chimeras. They were unfortunate in that the penny which they tossed did not have a head on each side. It remained spinning in the air for a long time, and finally came to a rest with the wrong superscription upwards. There is no excuse for the failure to present the claim in the state court. The complainants had many days in which to obtain every right which in justice and equity to them belonged. It would impugn the spirit of comity which prevails between the federal and state courts if, at this late day, this forum should extend its charitable arm to protect claimants confessedly negligent, even if their prayer have some equitable aspects. The arguments presented by each party, amplified to the last analysis, have been carefully considered, and a stirring disposition to discuss them seriatim is sternly repressed. A cordial assent is given to many valuable precedents to which attention has been directed, and especially to the very exhaustive reasoning of Judge Putnam in the late case of *Hale v. Coffin*, in the circuit court for the district of Maine, which appears in 114 Fed. 567. His discussion and citation of authorities have been exceedingly helpful.

Let the bill be dismissed, with costs.

FISK v. CITY OF NEW YORK.

(District Court, S. D. New York. December 3, 1902.)

1. COLLISION—DAMAGES RECOVERABLE—DEMURRAGE ON PLEASURE YACHT.

Demurrage is not recoverable for the time required to make repairs on a pleasure yacht, made necessary by a collision, where no actual pecuniary loss is shown; but the amount expended for wages and provisions for the crew is allowable, where their presence was necessary to care for the vessel.

In Admiralty. Suit for collision.

John F. Foley, for libellant.

John Whalen, for the City of New York.

ADAMS, District Judge. This is an action to recover damages caused to the libellant's yacht Admiral, by collision with the City's steamer Thomas S. Brennan, which occurred on the 28th of September, 1900, while the yacht was lying at anchor in the East River, within the anchorage grounds. No defence is interposed with respect to the libellant's right of recovery except as to the amount of damages. Disbursements in consequence of the collision, covering repairs and surveyor's fee, amounting to \$1108.58, are admitted by the City, but a claim of demurrage for sixteen days at \$100 per day, while the yacht was being repaired, is disputed.

No testimony has been taken to show that the owner suffered any loss of profits in a commercial sense from the accident, which it would be necessary to establish in order to recover demurrage on the yacht—*The Conqueror*, 166 U. S. 110, 133, 17 Sup. Ct. 510, 41 L. Ed. 937; *The Saginaw* (D. C.) 95 Fed. 703. Testimony was taken, however, showing that the libellant had expended \$572.13 in wages and food for the men employed on the yacht during the period of repairs, and a motion was made on the trial that the pleadings should be conformed to the proof in this particular. The decision in *The Conqueror* did not exclude expenses incurred during the detention, but approved an allowance for wages and provisions of the crew on board, which had been made upon testimony to the effect that it was necessary to have the men there to keep the vessel safely during the time. There is nothing here which directly shows that the men were necessary for the safe keeping of the vessel, but if any such expenses were incurred, I think the libellant should have an opportunity to establish them. A reference may be had upon this point, which will be at the libellant's expense unless he succeeds in establishing some right of recovery beyond the admitted amount.

Decree for libellant.

CHAPMAN v. ATLANTIC TRUST CO. et al.

(Circuit Court of Appeals, Ninth Circuit. November 10, 1902.)

No. 777.

1. CIRCUIT COURT OF APPEALS—JURISDICTION—JURISDICTIONAL QUESTIONS.

An order entered by a circuit court on the coming in of the final report of a receiver appointed by it in a foreclosure suit, denying the petition of the receiver, praying for a settlement of his accounts, and to have certain costs and expenses of the receivership adjudged against the complainant because of the insufficiency of the proceeds of the mortgaged property to pay the same, does not involve any question of jurisdiction, and an appeal therefrom lies to the circuit court of appeals, although such order was based on the ground that the court was without authority to require complainant to pay such costs and expenses.

2. APPEALABLE ORDERS—FINALITY.

Such an order, which involved a refusal by the court to settle the receiver's accounts, which had been left open for future adjustment by the decree confirming the sale of the mortgaged property, was final, and the receiver was entitled to appeal therefrom.

3. RECEIVERS—COSTS OF RECEIVERSHIP—POWER TO ADJUDGE AGAINST COMPLAINANT.

Where the costs and expenses of the management of mortgaged property by a receiver, authorized by the court, exceed the proceeds of the property when sold, together with its earnings, and the court has expressly retained jurisdiction over the subject-matter and the parties until the final settlement of the receiver's accounts, it has power on such settlement to render judgment for the deficiency against the complainant, at whose instance the receiver was appointed and continued, and the expenses were incurred.

Appeal from the Circuit Court of the United States for the Northern District of California.

Fox & Gray, for appellant.

J. J. Scrivner, for appellees.

Before GILBERT and ROSS, Circuit Judges, and HAWLEY, District Judge.

ROSS, Circuit Judge. In this suit, which was brought by the trustee of certain bonds issued by the defendant Woodbridge Canal & Irrigation Company, of the face value of \$1,000 each, bearing interest at the rate of 6 per cent. per annum, for the foreclosure of a mortgage given upon the property of the company as security for their payment, a receiver was appointed by the court at its beginning, who took possession of the property, consisting in part of an irrigation system, and continued its operation pending the litigation, and until the confirmation of its sale made under a decree of foreclosure and sale which was entered in the suit on the 18th day of September, 1897. That decree adjudged the principal and interest of the bonds to be due and payable to the trustee, and further adjudged that there was then due, owing, and unpaid, for and on account of the costs and expenses of the foreclosure of the mortgage and the manage-

¶ 1. Jurisdiction of circuit court of appeals, see notes to *Lau Ow Bew v. U. S.*, 1 C. C. A. 6; *Emigration Co. v. Gallegos*, 32 C. C. A. 475.

ment and care of the property pending the suit, the complainant's costs, taxed at the sum of \$——; and also: (a) To E. C. Chapman, the receiver, for and on account of advances made by him in the administration of the property pending the suit, "the sum of \$6,605.72, less \$3,500 now here paid thereon." (b) Also certain named sums, aggregating a large amount, due as of that date upon receiver's certificates duly issued by the receiver under the authority of the court, with interest upon the principal sum named in each of said certificates from the date of the final decree until paid at the rate of 10 per cent. per annum. (c) Also certain named sums, aggregating a large amount, adjudged to be then due certain named persons or their assignees upon time checks issued by the receiver for and on account of expenses incurred by him during his administration of the property. (d) Also certain specified sums, aggregating \$2,269.85, adjudged to be then due to certain named parties or their assignees "for and on account of work done and material and board furnished for men; the same having been performed and furnished for the said receiver, and for which no time checks or certificates have been issued." And next adjudging and decreeing that there be allowed and paid out of the proceeds of the sale of the property therein ordered, "as and for the further costs and expenses of this suit and of the care and management of the property pendente lite, the following sums, to wit: (e) To E. C. Chapman, receiver, as and for his compensation for his services as such receiver from the date of his appointment to the 1st day of October, 1897, the sum of \$9,000. (f) To Messrs. Fox & Gray, as and for their compensation as counsel for said receiver, the sum of \$9,000. And further adjudging and decreeing that "next after the payment of the sums hereinbefore mentioned, and before the payment of any sum for or on account of the principal or interest of any of the bonds so issued," there be allowed and paid out of the proceeds of said sale, as and for claims accrued against the Woodbridge Canal & Irrigation Company between November 3, 1893, and October 3, 1894, for expenses of operating the canal system, and necessary for keeping the same a going concern—

"And now here adjudged and decreed to be a prior lien upon said property, the following sums, to wit: (g) [Setting out the names of the various parties to whom the respective sums are adjudged, together with the amounts thereof.] (h) To W. O. Pidge for services rendered between October 13, 1893, and October 1, 1894, as civil engineer, and adjudged to be a prior lien upon said property, the sum of \$1,801.37. (i) To F. C. McClelland, on behalf of himself and as assignee of others, as set forth in his petition filed in this cause for services rendered in keeping the canals in a proper state of repair, the sum of \$922.12. (j) It is further ordered, adjudged, and decreed that, next after the payment of the sums hereinbefore mentioned, there be paid to Messrs. Scrivner & Schell and John B. Hall, solicitors for plaintiff in said cause, the sum of \$9,000. (k) To E. P. Cole and ——, solicitors on behalf of Buell & Co. and other interveners, holders of twenty-six of the bonds so issued as aforesaid, the sum of \$2,000."

And the decree further adjudged that:

"After the payment of the several sums hereinbefore mentioned, and not before, there be allowed and paid to the owners and holders of each of the several bonds hereinafter mentioned, upon the surrender thereof with the

relative coupons attached, the sum of \$1,210 on each of said bonds, with interest on the sum of \$1,000 of the moneys so due upon each of said bonds from the 1st day of September, 1897, to the date of payment, at the rate of six per cent. per annum, if the proceeds of said sale after the payment of the costs of sale and of the costs of suit, and of the several sums mentioned in subdivision 'a' to and including subdivision 'k,' shall be sufficient to pay in full the ninety-four bonds now here presented; otherwise that each of the seventy-nine bonds mentioned in this paragraph of this decree be paid pro rata in the proportion that the amount herein allowed upon each of said bonds bears to the whole amount of the fund so applicable to the payment thereof."

The final decree contained the further provision that "at such sale no bid shall be accepted for a less sum than \$120,000," with a subsequent provision declaring that "this decree is given and made subject to modification by the court at any time before final confirmation of sale, as to the upset or minimum price at which said sale may be made."

The provision specifying the limitations must subsequently have been modified, for in the decree confirming the sale, which was entered on the 15th day of August, 1898, it is recited that the commissioner appointed by the court to make the sale several times offered the property for sale in the mode and manner required by law, and in pursuance of the decree of sale, and having reported to the court the bids made in those proceedings, all of which were by the court rejected, and the matter having been again referred to the commissioner under order of the court, duly made, with instructions to again offer the property for sale after giving the required notice, and the commissioner having reported to the court his proceedings under that order, and all bids offered for the property thereunder, and the same having come on for hearing before the court on the 25th day of July, 1898, and having been continued from time to time until the 8th day of August, 1898, at which time all parties in interest were present by their respective counsel, and it being made to appear that at the time and place appointed for said sale the property had again been offered for sale in the manner required by law, and in pursuance of the orders of the court in that behalf made—

"Two bids had been made therefor, viz., one by Franklin Davis, of \$11,000 in gold coin, and twenty per cent. thereof deposited in gold coin with the said commissioner, accompanied with an agreement by said Franklin Davis that in case said bid was accepted by the court, and sale confirmed to him thereon, he would pay in the balance of said sum of \$11,000 in gold coin, or, in default thereof, forfeit the said deposit so made, and another by E. C. Chapman, the receiver, of \$22,350, payable as follows: By amount of claims of receiver, as allowed in and by the decree of foreclosure, \$12,105.72; by amount of claims of Fox & Gray, counsel for receiver, as allowed in and by said decree, \$9,039.43; balance to be paid in coin, \$2,354.85; making a total of \$23,500. Said bid subject to a lien upon the property for all further claims fixed by the decree and allowed as and for receiver's certificates and expenses incurred by the receiver in said cause, and upon which bid the said E. C. Chapman had deposited the sum of \$470.97 in cash, as and for twenty per cent. upon that part of said bid which was to be paid in cash, with an agreement that in case such bid was accepted, and confirmed by the court, he would make the same good, or in default thereof forfeit the sum so deposited."

The decree of confirmation further recites that exceptions filed to each of those bids came on for consideration, and after argument

the bid of Chapman was withdrawn, and that thereupon, upon motion of counsel, and with the consent and approval of all the parties in interest in the cause, the court consented to receive further bids in open court; and thereupon W. B. Bradbury and E. F. Card made and filed a bid in open court of the sum of \$12,000 in gold coin, and deposited 20 per cent. thereof, with an agreement that in case their bid was accepted they would pay in the balance thereof, or, in default of such payment, would forfeit the 20 per cent. so deposited, and that Charles N. Fox made and filed a written bid, signed by himself, in words and figures as follows:

"Now comes the undersigned, and bids and offers for the property offered for sale in this cause, and described in the decree of foreclosure heretofore entered herein, the sum of twenty-one thousand dollars; certificates, assignments, and conveyances thereof to be made to and in the name of G. Howard Thompson, and payment of the amount so offered and bid to be made as follows: (1) Nine thousand dollars thereof by the filing and entry of good and sufficient satisfaction and discharge of the allowance made in and by the said decree in favor of E. C. Chapman, receiver, as and for his compensation as receiver in said cause. (2) Nine thousand dollars thereof by the filing and entry of good and sufficient satisfaction and discharge of the allowance made in and by the said decree of foreclosure in favor of Fox & Gray, as and for compensation for their services as counsel for said receiver. (3) Three thousand dollars thereof in gold coin of the United States.

"[Signed]

Chas. N. Fox."

The decree of confirmation further recites that thereupon the further hearing of the matter was continued until August 10, 1898, at which time the hearing was resumed, when—

"Mr. Fox asked leave to substitute for the bid signed and filed by him on August, 8, 1898, a duplicate thereof signed by said G. Howard Thompson in person; and, leave being granted, a duplicate of the bid hereinabove last quoted, signed by the said G. Howard Thompson instead of by said Chas. N. Fox, was presented and filed, and substituted for the bid so signed by Chas. N. Fox, and with it was presented and filed, subject to acceptance and confirmation of said bid of said G. Howard Thompson, to be returned in case said bid should not be accepted and confirmed, a receipt in full for the said sum of nine thousand dollars, the allowance made in and by the said decree of foreclosure in favor of said E. C. Chapman, as and for his compensation as receiver in said cause, and also in full of the said sum of nine thousand dollars, allowance made in and by the said decree of foreclosure in favor of Fox & Gray, as and for their compensation for their services as counsel for said receiver, which receipt was signed by the Bank of California, by its assistant cashier, also by the said E. C. Chapman and by the said Fox & Gray; and with the said papers was also deposited, subject to acceptance and confirmation of said bid, to be returned in case the same was not accepted and confirmed, a certified check, covering the amount of the cash portion of said bid and one thousand dollars in excess thereof, also two hundred dollars in gold coin of the United States, making the total of said deposit of check and coin of \$4,200, being equal to twenty per cent. upon the total amount of the bid so made as aforesaid, and accompanying the same with a written agreement made by said E. C. Chapman and Fox & Gray, who made said deposit of check and cash, that in case said bid of said G. Howard Thompson was accepted and confirmed according to the terms thereof, and default be made in complying with the terms thereof on the part of said G. Howard Thompson, then the full amount of said \$4,200 so deposited in check and cash should be forfeited; otherwise three thousand dollars thereof to be used in complying with the terms of said bid, and the remaining \$1,200 thereof to be returned to them."

The decree of confirmation further recites that "said Franklin Davis also made a second bid, in the sum of \$12,500 in gold coin of the United States, with an agreement in writing to forfeit twenty per cent. thereof in case said bid was not made good, if accepted and confirmed, and deposited a certified check more than sufficient to meet the said twenty per cent. upon said bid," and further recites that, exceptions having been taken to the acceptance and confirmation of each of the bids, the same were argued and submitted, whereupon the court rejected the bids of Davis and of Bradbury and Card. The decree of confirmation then recites that:

"It appearing to the court that the said sums of nine thousand dollars allowed and decreed, in and by said decree of foreclosure, to be paid to the said E. C. Chapman, receiver, as and for his compensation as receiver, and of nine thousand dollars allowed and decreed, in and by the said decree of foreclosure, to be paid to Fox & Gray as and for their compensation as counsel for said receiver, are costs of court, entitled to priority of payment out of the proceeds of such sale next after the costs of sale; and it further appearing that no higher or better bid has been or can be secured for said property, it is by the court further ordered, adjudged, and decreed that the bid so made by the said G. Howard Thompson be, and the same is hereby, accepted, according to the terms thereof, and that said property be struck off and sold to him therefor; that satisfaction and discharge of so much of said decree of foreclosure as provides that the sum of nine thousand dollars be allowed and paid to said E. C. Chapman as and for his compensation as receiver, and of so much thereof as allows and decrees that the sum of nine thousand dollars be allowed and paid to Messrs. Fox & Gray as and for their compensation for services as counsel for said receiver, and the said sum of three thousand dollars in gold coin, for which check was deposited as aforesaid, be accepted in satisfaction of said bid, and thereupon the balance of the money so deposited on behalf of said G. Howard Thompson, to wit, the sum of \$1,200 so deposited to make up the twenty per cent. of the entire bid, required as security that the said bid would be made good, be thereupon returned to the parties making the deposit aforesaid."

And further decreeing that the commissioner appointed to make the sale execute to Thompson the proper certificates and assignments of the property, and that, in case redemption be not made of the property from such sale within six months from the 10th day of August, 1898, the commissioner execute to the purchaser good and sufficient deeds of conveyance of all the property so sold, and that upon presentation of such conveyances, and demand made therefor, the receiver deliver over possession of all the property so sold and conveyed to the purchaser or his assigns.

The decree of confirmation further adjudged that out of the money arising from such sale—

"The clerk pay the costs of advertising and sale, including the compensation allowed to the commissioner for making such sale, as fixed and established in said decree of foreclosure; the fees of the master on the reference made to him to examine and report upon the receiver's report of receipts and expenses prior to the entry of said decree; the clerk's accruing costs and commissions; and that he apply and pay the balance, if any there be, in payments pro rata on the receiver's certificates mentioned and provided for in said decree of foreclosure; such payments to be applied first to the accrued interest on said certificates, respectively, and, if more than sufficient to pay such accrued interest, then on account of the principal of such certificates respectively; and that said clerk report to this court the balance then due and remaining unpaid for or on account of any of the fees of officers or

appointees of this court, or of advances made by them or either of them, and for or on account of receiver's certificates or time checks or other expenses of the administration of said receiver, as the same are fixed, established, and allowed in and by the said decree of foreclosure, for the further consideration and action of this court thereon; and also that the said receiver report to this court, and render an account of his receipts, disbursements, and expenses in the management and care of said property between the date of said decree of foreclosure and the date of sale, and transfer of possession thereunder, for examination and settlement."

The decree of confirmation concluded with the express provision—
 "That jurisdiction of this cause and the parties thereto be, and the same is hereby, retained by the court, until redemption is made or title deeds have passed as herein provided, and until the coming in of the reports of the said clerk and receiver herein provided for, and the final action of the court thereon, and the final payment of the balance of the costs and expenses of this court and its officers, and of the advances made and indebtedness incurred by said receiver, which have been or may be allowed by the court, in the management and care of the property placed in his charge, or until the further and final order of the court in that behalf."

Pursuant to the requirements of the decree of confirmation, the clerk of the court on the 7th day of September, 1898, filed the following report:

"Report of Clerk Pursuant to Decree of August 15, 1898.

"To the Honorable William W. Morrow, United States Circuit Judge: In obedience to the decree of confirmation of sale, filed August 15, 1898, I respectfully report that the following payments have been made from the proceeds of sale under decree of foreclosure:

Proceeds of sale.....	\$21,000 00	
The receiver for his compensation.....	\$ 9,000 00	
Messrs. Fox & Gray, as attorney's fees.....	9,000 00	
E. H. Heacock, commissioner, etc.....	500 00	
E. H. Heacock, master, etc.....	50 00	
Advertising bills	1,737 60	
Stenographer's fees	20 00	
Clerk's costs	201 70	
Pro rata payment on the accrued interest on the receiver's certificates	490 70	
		<hr/>
	\$21,000 00	\$21,000 00

"I further report that of the amounts found due by the decree of foreclosure of September 18, 1897, there remains still unpaid:

Receiver's certificates	\$12,292 47
E. C. Chapman, Esq., receiver, for advances made by him, care and management of the property.....	3,105 72
Time checks issued by receiver.....	5,728 89
Work done and material furnished for said receiver, for which no time checks or certificates have been issued.....	2,269 85
Expenses operating canal system.....	5,728 54
W. C. Pidge	1,801 37
F. C. McClelland	922 12
Scrivner & Schell and John B. Hall.....	9,000 00
E. P. Cole	2,000 00
	<hr/>
	\$42,848 96

"Respectfully submitted,
 Southard Hoffman,
 "Clerk United States Circuit Court, Northern District of California.
 "September 7, 1898."

And on the 3d day of August, 1899, nearly one year after the above report of the clerk, the receiver filed in the cause his "final report and petition." In that report the receiver starts out by referring to the entry of the decree of foreclosure and sale, and the appointment of a commissioner to make the sale, and recites that:

"Although the most diligent effort was made, and a large expense incurred, in trying to effect a sale, no sale was finally made of the property at a price satisfactory to either the parties in interest or the court until the 10th day of August, 1898, when the property was struck off and sold to G. Howard Thompson for the sum of \$21,000, that being the highest and best bid made therefor; and decree of confirmation of such sale, subject to redemption within six months, as provided by the laws of the state, was duly given and made on the 15th day of August, 1898, and certificates of such sale duly executed and delivered and filed."

The report of the receiver further states that from the date of the decree to the date of the sale and its confirmation, and the issue of the certificate of sale thereunder, it was necessary that the receiver should, and that he did, remain in full and absolute charge and possession of the property, and that, although he did not attempt during that period to keep it "a going concern, as he had theretofore done," it was necessary for him to give, and that he did give, the matter his personal attention from time to time, and made three visits of inspection to the property, at an expense of \$47.40, actually paid out by him, and that it was also necessary during the whole of that time, in order to preserve the property, that the receiver should keep, and that he did keep, three men employed for 12 months, at a cost of \$75 a month each, one of whom was employed at the headquarters of the works, at Woodbridge, and the other at the upper water right, in Calaveras county; that he also necessarily incurred further expenses in the care and management of the property during that period, as shown in his account embodied in the report; that during all the same period his counsel was engaged and was frequently consulted by the receiver upon questions of law which arose in the conduct and management of the business, and in that behalf prepared and filed many papers in the case, and had and attended many hearings and arguments before the court in the matter of the receivership. Succeeding the foregoing statements of the report of the receiver is the following:

"Pending the sale of such property, and on the 1st of February, 1898, under authority given by order of court made on that day, I sold and assigned a note and mortgage given by Thomas E. Jones to the said Woodbridge Canal & Irrigation Company, dated June 25, 1894, for the sum of \$500 cash, which I received, out of which I returned the sum of \$175, money which I had received on account of interest on another mortgage which had come into my possession as receiver, and which I had supposed belonged to the assets of the Woodbridge Canal & Irrigation Company at the time of making my former report in this cause, but which had in fact been assigned and transferred by the Woodbridge Canal & Irrigation Company before my appointment as receiver, leaving a balance of the moneys so received by me of \$325. Since my last report I have paid out to and for F. C. McClelland, on account of services rendered by him, the sum of \$772, leaving a balance of \$128 still due him on account of services so rendered since my last report, and in addition to the sum of \$300 due to him for services prior to my last report, and allowed in and by the decree of foreclosure entered herein. My disbursements and receipts since the date of my report upon which the said decree was based have been as follows:

Disbursements:

Interest erroneously collected, as above stated.....	\$ 175 00
Paid F. G. McClelland on account of services rendered.....	772 00
Paid costs and expenses of witnesses before the commissioner on settling my former account.....	35 00
Paid expenses of three trips made by myself to the works.....	47 40
Total	\$1,029 40
Receipts	500 00

Which, being deducted from my disbursements, leaves balance
due on account of expenses..... \$ 529 40

"There is also a balance due to said F. G. McClelland on account of services rendered since my last report of \$128, and also due J. J. Hinckley for services since my last report of \$900. To these should also be added such reasonable sum as the court shall deem to be just for my services as receiver for the period of twelve months from the date of my last report. And also to my counsel, Chas. N. Fox, such reasonable sum as to the court shall deem proper and just for his services during the same period.

"It also appears from the report of the clerk of this court, made in pursuance of the order of confirmation of such sale, that there is a deficiency on account of the expenses and costs incurred by the receiver prior to the entry of said decree of foreclosure, and which were allowed and established by the said decree, in the following sums, to wit:

On account of receiver's certificates outstanding.....	\$12,292 47
In favor of this receiver for advances.....	3,105 72
On account of time checks issued by receiver, and now out- standing	5,728 89
On account of work done and material furnished for which no time checks or receiver's certificates were issued.....	2,269 85

"Of this amount, the sum of \$10,265.15 (being the principal due upon said receiver's certificates) bears interest at the rate of ten per cent. per annum from the date of said decree, and the balance of said several sums bears interest at the rate of seven per cent. per annum from the date of said decree."

The report of the receiver next avers—

"That each and all and every of the foregoing items of expenditure and of the several sums of money hereinbefore mentioned are costs and expenses of this court and its officers necessarily incurred in the prosecution of said action, and for which the plaintiff in said action is primarily liable [liable] under the laws of the United States and of the state of California, and the rules and practice of the court; that they were incurred on the motion and the request of the said plaintiff; that of right they should have been paid in advance by the said plaintiff, but upon the assurance of said plaintiff that the property against which it was seeking to foreclose was amply sufficient to pay all the costs and expenses so incurred, and the whole amount of the indebtedness for which said action was brought, they were not so paid, but were left to be paid out of the funds arising from the sale of said property; that the proceeds of such sale were wholly insufficient to pay even the costs and expenses of the court in that behalf; and that after applying the proceeds of sale to the satisfaction of the costs and expenses of sale, and of the compensation allowed to the said receiver and his counsel in and by the said decree of foreclosure, as authorized by the court, the amounts hereinbefore stated remain still unpaid and entirely unsatisfied."

The report and petition of the receiver also contained certain allegations intended and tending to show that the suit was originally commenced without legal right and by collusion between the complainant trustee and the defendant Woodbridge Canal & Irrigation Company.

The prayer of the receiver is—

"That the balance due him on account of his receipts and disbursements since the making of said decree, and also the balance due to his employés, as hereinbefore stated, since the making of the report upon which said decree was based, and the compensation to be allowed to the said receiver and to his counsel since the date of said decree, be fixed and established by this court, and that judgment be entered in favor of this receiver or of the clerk, or such other officer of the court as the court shall direct, against the plaintiff in this cause, for the full amount of the deficiency hereinbefore stated, with the sums so allowed for services and expenses since the date of said decree, and that the proper process of court be issued for the collection thereof from plaintiff, and that when collected the same be paid into court, to be by the court disbursed to the several persons entitled thereto."

Upon the filing of the report and petition of the receiver, the court made an order on the complainant to show cause at a designated time—

"Why the amount due to the receiver and his employés under his final report should not be settled and allowed, and why judgment for the total amount of such deficiency, when ascertained, should not be entered against the said Atlantic Trust Company, plaintiff in said cause, and why said plaintiff should not be required to pay the same into court, as in the said petition prayed."

The complainant appeared in answer to the order to show cause, and filed a demurrer to the report and petition of the receiver, upon the grounds, among others, that the court was without jurisdiction to grant the relief prayed for, and that neither the report nor the petition stated facts sufficient to justify the court in granting the relief prayed for. After argument, the petition and demurrer were submitted to the court below, in deciding which the judge said:

"I am of the opinion that provision should have been made when this suit was commenced, or at the time when the receiver was appointed, for the payment of or security for the amount of his expenses, and for the redemption of whatever certificates might be issued by him, in the event that the proceeds of the sale of the property should prove insufficient. But such provision was not made at the time by the court, and I am of the opinion that the court is without authority to do so now. In *Farmers' Loan & Trust Co. v. Oregon Pac. R. Co.*, 31 Or. 237, 48 Pac. 706, 38 L. R. A. 424, 65 Am. St. Rep. 822, this question was fully considered, and the views there expressed are in accord with my opinion in the present case. The order to show cause will therefore be discharged."

And on the same day the following order in the matter was entered in the minutes of the court:

"In this cause the receiver's application [by order to show cause] for an order directing complainant to pay the amount due to receiver and his employés, etc., heretofore heard and submitted, having been fully considered, and the memorandum opinion of the court having been filed, it was in accordance therewith ordered that the order to show cause in this behalf issued herein be, and hereby is, discharged, and that receiver's said application be, and hereby is, denied."

The appeal is from this order.

A motion is made to dismiss the appeal, based upon two grounds: First, that, as the demurrer to the receiver's report and petition set up that the court below was without jurisdiction to grant the relief sought, it raised a question of jurisdiction, which was required to be certified to the supreme court, under the provisions of the act of congress creating this court (26 Stat. 826 [U. S. Comp. St. 1901, p. 547]); and, secondly, that the order appealed from is not a final order

or decree of the circuit court. We think it clear that there is no merit in either of these points. It is not pretended that the court below was without jurisdiction of the parties to the suit, or of its subject-matter, nor that it was without jurisdiction to appoint a receiver to take possession of and hold and operate the property pending the litigation. It follows, as a matter of course, that it had the power and that it was its duty to overlook and adjust the accounts of the receiver, and to adjudge how and when the costs and expenses of the receivership should be paid,—subject, of course, to correction, by appropriate proceedings, of any error committed in that respect. And in this case the court below, in its decree confirming the sale of the property, in express terms, retained jurisdiction of the cause for those purposes. It was in pursuance of that express provision of the decree of confirmation that the report and petition of the receiver was filed, and action thereon by the court sought; thus not only invoking a power expressly reserved in the decree of confirmation, but one of the powers of the court incident to its unquestioned jurisdiction over the parties to and the subject-matter of the suit. There is just as little merit in the contention that the order appealed from is not a final order. It is a mistake to say that by the order the court below did not refuse to settle the accounts of the receiver. The petition was for the settlement of the receiver's account, as well as for an order that the complainant in the cause be directed to pay the full amount of the deficiency shown thereby. The order to show cause directed the complainant to appear at a time and place designated, and show, if it could, why that relief should not be granted. Upon hearing and considering the matter, the receiver's application, which, as has been said, included a prayer both for the settlement of his accounts, and a judgment against the complainant for the deficiency shown thereby, was denied, and the order to show cause discharged. Nothing could more effectively and completely end the application than that order. It was final, in the strictest sense, and it was an order from which the receiver was entitled to appeal, for two reasons: First, because the account the receiver sought to have settled and allowed and ordered paid contained an unpaid balance of \$3,105.72 that had been theretofore adjudged by the court to be due him on account of the expenses of the receivership; and, secondly, because it was his legal duty to exercise his powers as receiver, and see that the certificates that he had issued and sold under the authority of the court, as well as all other legitimate expenses of the receivership, be paid. We regard the decision of the supreme court in the case of *Bosworth v. Railway Co.*, 174 U. S. 182, 19 Sup. Ct. 625, 43 L. Ed. 941, as full authority for the appeal by the receiver. The motion to dismiss is therefore denied.

In considering the merits of the appeal, we should not be controlled or in any way influenced by the fact that the sale of the property seems to have been in reality made and confirmed to the receiver and his attorney, through Thompson, for \$21,000, \$18,000 of which was paid by the satisfaction of the allowance in that amount that had theretofore been made to the receiver and his attorney for their services in their respective capacities. Neither the propriety

of the confirmation of the sale so made, nor that of any other of the provisions of the decree of confirmation, is before us for consideration. That decree, including the order of payments therein specified, must be here accepted as it stands. Nor does any objection appear to have been at any time taken by the complainant to the sale or to its confirmation, or to any of the provisions of either the original decree of foreclosure and sale, or that confirming the sale. In and by the latter, as has been shown, the court below in express terms retained jurisdiction of the cause and of the parties thereto "until redemption is made or title deeds have passed, as herein provided, and until the coming in of the reports of the said clerk and receiver herein provided for, and the final action of the court thereon, and the final payment of the balance of the costs and expenses of this court and its officers, and of the advances made and the indebtedness incurred by said receiver which have been or may be allowed by the court in the management and care of the property placed in his charge, or until the further and final order of the court in that behalf." In obedience to the requirements of that decree, the report of the receiver was filed. It does not, we think, admit of question that the court should have settled the account of the receiver, and that in discharging the order to show cause, and dismissing the petition of the receiver, embracing, as has been shown, a prayer for its settlement, as well as for an order that the complainant pay the deficiency shown thereby, the court below was in error. The account filed by the receiver shows, among other things, that there remains due and unpaid on the certificates issued by the receiver under the orders of the court, and for other allowed and adjudged expenses of the receivership, a large amount of money, which fact is referred to in the opinion of the court below, but concerning which the learned judge, in discharging the order to show cause and denying the receiver's application, said:

"I am of the opinion that provision should have been made when this suit was commenced, or at the time when the receiver was appointed, for the payment of or security for the amount of his expenses, and for the redemption of whatever certificates might be issued by him, in the event that the proceeds of the sale of the property should prove insufficient. But such provision was not made at the time by the court, and I am of the opinion that the court is without authority to do so now. In *Farmers' Loan & Trust Co. v. Oregon Pac. R. Co.*, 31 Or. 237, 48 Pac. 706, 38 L. R. A. 424, 65 Am. St. Rep. 822, this question was fully considered, and the views there expressed are in accord with my opinion in the present case."

On principle, it seems to us impossible to assign any good reason why, if the court was empowered at the time of the commencement of the suit, or at the time of the appointment of the receiver, to compel the complainant to pay into court sufficient money to cover the expenses of the receivership, or to give security for such payment, including the payment of whatever certificates might be authorized to be issued by the receiver, the court has not precisely the same power to adjudge, upon the settlement of the receiver's account, that the complainant make good any deficiency in the matter of such expenses; having by its decree, in express terms, retained jurisdiction of the cause and of the parties thereto for the purpose of settling

the receiver's account, and ordering paid the costs and expenses of the receivership. The case of *Farmers' Loan & Trust Co. v. Oregon Pac. R. Co.*, 31 Or. 237, 48 Pac. 706, 38 L. R. A. 424, 65 Am. St. Rep. 822, relied upon and approved by the court below, does not commend itself to our judgment. The court there said:

"It is not perceived upon what ground it can be claimed that, because the expenses of the receivership are allowed, without any fault of his, to exceed the value of the mortgaged property, thus entirely destroying his security, he must, in addition to the loss of his debt, be compelled to make good the deficit, unless the order of appointment was made upon that condition. He has no control over the acts of the receiver, and if, without his consent, he is to be held responsible therefor, he is liable to absolute bankruptcy and ruin. Such a rule would render the plaintiff's position so uncertain and precarious as practically to preclude him from any protection whatever through the appointment of a receiver pending the foreclosure suit. But the inquiry is made, 'Shall not a railroad mortgagee, who applies for and obtains the appointment of a receiver, with authority to operate the road, be held responsible for the liabilities incurred by such officer, when they cannot be made out of the property itself?' We think not, unless such responsibility was imposed as a condition to the appointment or the continuance of the receiver in office. The appointment of a receiver in a suit to foreclose a railroad mortgage is not a matter of strict right, but rests in the sound judicial discretion of the court; and it may, as a condition to issuing the necessary order, impose such terms as may, under the circumstances of the particular case, appear to be reasonable, and, if not acceded to, may refuse to make the order. 30 Am. Law Rev. 161; *Fosdick v. Schall*, 99 U. S. 235, 25 L. Ed. 339. If, therefore, upon an application for the appointment of a railroad receiver, it appears probable that the income and corpus will prove insufficient to pay the expenses and liabilities thereof, we have no doubt that the court may require of the plaintiff, as a condition to such appointment, a guaranty of the payment of the expenses of such officer. And if, at any time after the appointment has been made, it becomes apparent to the court that it will be unable to pay and discharge the present or future liabilities incurred by its executive officer and manager, it should refuse to continue the operation of the road under the receiver, unless its expenses are guaranteed. No court is bound or ought to engage or continue in the operation of a railroad or any other enterprise without the ability to promptly discharge its obligations, and unless it can do so it should keep out or immediately go out of the business. But unless such terms are imposed as a condition of the appointment or continuation in office of the receiver, his employes must look to the property in the custody of the court and its income for their compensation. They have no claim whatever on any of the parties to the litigation. They are the employes and servants of the court, and not of the parties. Their wages are in no sense costs of the litigation, and, although incurred during the progress of the suit, they are not incurred in the suit. They are neither expenses of the plaintiff nor of the defendant, and are not fees or costs which can be charged against the successful party to the litigation, as is sought to be done in this case."

The party who asks for the appointment of a receiver does so voluntarily, and because he thinks it to his interest to have the possession of the property in controversy pass into the hands and control of the court pending the litigation. It is true that the receiver, when appointed, becomes the officer of the court, and not the agent of either party to the suit, but he is appointed to serve the parties interested. He holds the property, and, when operating it, operates it for the benefit of whomsoever shall be finally adjudged to own it. But he cannot be justly held to hold it and operate it at his own expense or that of the court. Those who render services in and about the receivership are justly entitled to be paid the fair value of such services,

and when the issuance of receiver's certificates becomes necessary for the proper preservation of the property, and such certificates are authorized by the court to be issued by the receiver for money to be used for such purposes, those who buy the obligations are entitled to have them paid. How? In cases like the present, out of the property or its proceeds, certainly. No one, we apprehend, will question that. But the property having been sold for but a trifle more than the amount theretofore allowed the receiver and his attorney for their services in and about the receivership, and they credited with such allowance on their bid, who is to suffer? The complainant, at whose instance the receiver was appointed, or those who, relying upon his acts, based upon the authority and sanction of the court, invested their money and rendered their services in and about the operation and preservation of the property? It is not difficult to determine on which side of this question are the equities. With due deference, we are unable to see any force in the suggestion of the supreme court of Oregon in the case cited that, as the complainant in such a suit has no control over the receiver, if he be held liable for the expenses of the receivership, in the event the property prove insufficient to pay them, he may be bankrupted. At the same time it is conceded by that learned court that, where it appears probable that the property will prove insufficient, the court may require, as a condition to the appointment of a receiver, a guaranty of the payment of the expenses of such officer, and a like guaranty subsequently, on pain of the discharge of the receiver, when it becomes evident that the property will prove insufficient to pay the expenses. The theory of this manifestly is that in these two instances the complainant can inform himself of the probable outcome of the property, and, if he be not willing to give the guaranty, he will not secure the appointment of a receiver in the one instance, or his continuance in office in the other. But why should he not be required to inform himself, also, when no such condition is imposed by the court? Precisely the same opportunity on complainant's part, and precisely the same duty to inform himself in that respect, exists in the absence of the requirement of the guaranty mentioned. The complainant, whose lien upon the property it is sought to foreclose, in the nature of things, must and should be held to have much better information regarding the value of the property and its probable outcome than the court. Indeed, it is not easy to see how the court can be properly expected to know anything about it. The appointment of a receiver, if made at all, is usually made at the request of the complainant,—occasionally, as in the case at bar, with the consent of the defendant. If the complainant was not willing to pay the expenses of the receivership it asked for, in the event of the insufficiency of the property to do so, it should not have asked the court to make the appointment, incur the liabilities, and pledge its faith to their payment. It was the duty of the complainant to keep informed in respect to the progress of the receivership, the property, and its probable outcome, and, whenever it became unwilling to further stand good for any deficiency, to ask the court to bring to an end the business it undertook and was conducting on complainant's petition.

We are therefore of opinion that the complainant is liable for the deficiency shown by the decrees already rendered in the cause, and for such further deficiency as may be properly ascertained; and such is the decided weight of authority. See Beach, Rec. (Anderson's Ed.) § 773; Ephraim v. Bank, 129 Cal. 589, 62 Pac. 177; Pacific Bank v. Madera Fruit & Land Co., 124 Cal. 525, 57 Pac. 462; Tome v. King, 64 Md. 166, 21 Atl. 279; Howe v. Jones, 66 Iowa, 156, 23 N. W. 376; Cattle Co. v. Bindle (Tex. Civ. App.) 32 S. W. 582; Knickerbocker v. Mining Co., 67 Ill. App. 291, affirmed in 172 Ill. 535, 50 N. E. 330, 64 Am. St. Rep. 54; Bank v. Backus (Minn.) 77 N. W. 142; Mining Co. v. Schoolfield, 15 Colo. 376, 24 Pac. 1049; Cutter v. Pollock, 7 N. D. 631, 76 N. W. 235.

We are further of opinion that upon the settlement of the receiver's account, and the proper ascertainment of such further deficiency, if any, judgment may be entered against the complainant for the aggregate amount thereof; jurisdiction over the cause and of all of the parties having been retained by the court for that purpose. What that further deficiency, if any, properly chargeable against the complainant, may be, will be a matter for the determination of the circuit court on a settlement of the receiver's account. It is not for us to anticipate its action thereon in any respect.

Order reversed and cause remanded for further proceedings not inconsistent with this opinion.

ELLIOTT v. FELTON.

(Circuit Court of Appeals, Sixth Circuit. December 2, 1902.)

No. 1,076.

1. STATE COURT—CONSTRUCTION OF STATUTE—WHAT CONSTITUTES—BINDING EFFECT ON FEDERAL COURT.

Shannon's Code Tenn. § 4025, provides that the right of action which a person who dies from injuries from another, or whose death is caused by the wrongful act, etc., of another, would have had against the wrongdoer in case death had not ensued, shall not abate or be extinguished by his death, but shall pass to his widow, etc. Sections 4026-4028 authorize the personal representative or widow to sue, and provide that, if the deceased has sued, the action may proceed after his death without revivor. Section 4029, being an amendment to the original act, provides that the party suing may recover for the suffering, loss of time, etc., resulting to the deceased, and also the damages resulting to the parties for whose use and benefit the right of action survives. The supreme court of Tennessee has held, notwithstanding section 4029, that this statute does not create a new liability, but merely continues decedent's cause of action by abrogating the common-law rule abating personal actions on the death of the plaintiff. *Held* that, as the liability is not created, but merely preserved, by statute, a decision of the supreme court of Tennessee, in an action for wrongful death, that the conductor of a railroad train was a vice principal, and not a fellow servant towards the brakeman, did not define a statutory liability so as to be binding on the federal courts as a construction of a state statute.

¶ 1. State laws as rules of decision in federal courts, see notes to Griffin v. Wheel Co., 9 C. C. A. 548; Wilson v. Perrin, 11 C. C. A. 71; Hill v. Hite, 29 C. C. A. 553.

2. SAME.

The decision holding a conductor to be a vice principal, having professedly proceeded on general grounds, must be regarded as one of general law, and not as involving the construction of a statute.

In Error to the Circuit Court of the United States for the District of Tennessee.

Charles M. Cist, for plaintiff in error.

Edward Colston, for defendant in error.

Before LURTON, DAY, and SEVERENS, Circuit Judges.

LURTON, Circuit Judge. This was an action to recover damages for the negligent killing of Simon Matthews, the intestate of the plaintiff in error. Deceased was a brakeman in the employment of the defendant, and was killed in collision through the negligence of his own conductor. The court below, upon this conceded state of facts, instructed the jury that the deceased and his conductor were fellow servants, and that the defendant receiver was not liable for an injury of one fellow servant by another in the same common service. This instruction is assigned as error upon the ground that the collision occurred in Tennessee, and that the question of fellow servant was erroneously decided under the law of Tennessee. Confessedly, there is no statute in Tennessee defining fellow servant, or regulating the liability of an employer to his servant for the negligent acts of either the master or each other. So, also, it is not disputed but that, if the question is one of general, and not local, law, the conductor in charge of a train is the fellow servant of a brakeman on the same train. *Railroad Co. v. Conroy*, 175 U. S. 323, 20 Sup. Ct. 85, 44 L. Ed. 181. District Judge Evans followed this decision in the court below, and refused to be governed by *Railroad Co. v. Spence*, 93 Tenn. 174, 23 S. W. 211, 42 Am. St. Rep. 907, where it was held that the power of control exercised by the conductor over his train and its crew constituted him a vice principal, and not the fellow servant of a brakeman. Judge Evans is said to have erred in refusing to follow the Tennessee decisions as to the law of fellow servants, not because there is any statute regulating the subject upon which the decisions were based, but because this action, being one for negligent death of the deceased, is an action which would at common law have been extinguished by the death of the injured person, and is now prosecuted only by virtue of a Tennessee statute which prevents such extinguishment. Upon this premise it is insisted that every decision of the supreme court of Tennessee determining under what circumstances a liability exists for a negligent killing is a decision construing, interpreting, and applying the Tennessee survival statute, and for that reason a decision to be followed by this court as a decision construing a local statute. That the construction given to a statute of a state by the highest court of that state is to be regarded and followed by this court as a part of the statute itself is well settled. The construction of the Tennessee supreme court of the Tennessee statute prescribing precautions to be observed by railway companies in order to prevent accidents in the operation of trains, and holding that contributory negligence by the plaintiff was not a bar to an action based upon a nonobservance of the statute, was

followed by this court as an obligatory determination of the meaning of the act. *Byrne v. Railroad Co.*, 9 C. C. A. 666, 61 Fed. 605, 24 L. R. A. 693; *Railroad Co. v. Roberson*, 9 C. C. A. 646, 658, 676, 61 Fed. 592; *Leffingwell v. Warren*, 2 Black, 599, 17 L. Ed. 261; *Bucher v. Railroad Co.*, 125 U. S. 582, 8 Sup. Ct. 974, 31 L. Ed. 795; *Railway Co. v. McCann*, 174 U. S. 586, 19 Sup. Ct. 755, 43 L. Ed. 1093. In the interpretation and construction of the Tennessee act providing for the survival of actions for the negligent death of a deceased person—the act by virtue of which this action was brought—we have never hesitated to follow the meaning placed thereon by the supreme court of the state. *Railway Co. v. Hooper*, 35 C. C. A. 24, 92 Fed. 820; *Sanders' Adm'x v. Railroad Co.*, 49 C. C. A. 56, 111 Fed. 708. The question, therefore, for decision here, is, not whether the construction of the Tennessee survival statute by the supreme court of Tennessee will be followed by this court as authoritative, but whether the decisions relied upon as an interpretation of that statute are in fact such.

The act in question was passed in 1851, and was carried into the Tennessee Code of 1858, being now section 4025, Shannon's Code of Tennessee, and reads as follows:

"4025 (2291) 3130. Right of Action in Case of Injuries or Death.—The right of action which a person who dies from injuries from another, or whose death is caused by the wrongful act, omission, or killing by another, would have had against the wrongdoer in case death had not ensued, shall not abate or be extinguished by his death, but shall pass to his widow, and, in case there is no widow, to his children, or to his personal representative, for the benefit of his widow or next of kin, free from the claims of creditors. (1851-52, ch. 17; 1871, ch. 78, sec. 1.)"

Sections 4026 and 4027 provide that the action may be brought by the personal representative of the deceased, or by the widow, or, if no widow, then by the children. Section 4028 provides that, if the deceased had commenced an action, it may proceed after his death without revivor. Section 4029 is an amendment made by chapter 186 of the act of 1883, and reads as follows:

"4029. 3134. Measure of Damages.—Where a person's death is caused by the wrongful act, fault or omission of another, and suit is brought for damages, as provided for by sections 4025 to 4027, inclusive, the party suing shall, if entitled to damages, have the right to recover for the mental and physical suffering, loss of time and necessary expenses resulting to the deceased from the personal injuries, and also the damages resulting to the parties for whose use and benefit the right of action survives from the death consequent upon the injuries received. (1883, ch. 186.)"

The contention of the plaintiff in error is that the act "creates a liability on the part of the wrongdoer and in favor of the administrator unknown to common law," that "the liability exists solely by the will of the legislature of Tennessee." "It is not," says the very learned attorney for the plaintiff, "a mere continuation of the common-law right of action for negligence which the deceased would have had if he had lived, and a removal of the bar which the common law interposed on the death of the injured person, as expressed in the maxim, 'Actio personalis moritur cum persona,' but it is an entirely new liability, and an entirely new cause of action." These statutes abrogating the common-law rule by which the right of action for a

personal injury died with the person are of comparatively recent origin, and vary in important particulars. In *Dennick v. Railroad Co.*, 103 U. S. 21, 26 L. Ed. 439, it was said:

"The questions growing out of these statutes are new, and many of them are unsettled. Each state court will construe its own statute on that subject, and differences are to be expected."

1. The highest court of Tennessee has authoritatively construed the Tennessee act as not creating a new cause of action, but as simply preserving the decedent's right of action, which would otherwise be extinguished by his death. The original of these survival acts was the English act known generally as "Lord Campbell's Act," and the original of the American acts was that of New York, which latter act was subsequently copied by most of the American states. Both the English act and the New York act were peculiarly worded, and were construed as taking no account of the injury to the deceased in the damages recoverable, but only of the pecuniary loss of the persons entitled by the act to the benefit of the recovery. The Tennessee act does not copy either the New York or the English act, and has consequently received an entirely different interpretation. Thus, in one of the earlier cases under the act,—that of *Railroad Co. v. Burke*, 6 Cold. 45, 49,—it was said:

"The cause of action is the injury to Burke, and the right of action of the personal representatives is for that cause of action, and is the right of action Burke had, and could have prosecuted had he lived, and the damages recoverable are for that cause of action. The statutes of other states, which have been cited, * * * either by express terms or plain implication, give the next of kin a right of action or damages for the injury done them by the killing of the deceased. The Tennessee statute goes no further than to give the next of kin the damage that may be recovered by the personal representatives for the injury done his decedent."

In a number of cases following this case of *Railroad Company v. Burke* it has been held that, unlike the English act, and those worded as that, the Tennessee act simply abrogates the artificial rule of the common law by which personal actions die with the person. *Jones v. Littlefield*, 3 Yerg. 133; *Governor v. McMannus' Adm'rs*, 11 Humph. 152; *Hall v. Railroad Co.*, Thomp. Tenn. Cas. 204; *Railroad Co. v. Prince*, 2 Heisk. 580; *Fowlkes v. Railroad Co.*, 9 Heisk. 829; *Trafford v. Express Co.*, 8 Lea, 96, 102, 109; *Railroad Co. v. Smith*, 9 Lea, 470-474. In *Fowlkes v. Railroad Co.*, cited above, it is said:

"If an action be brought by the party himself, and he then dies of the injury before judgment, the effect of the statute is to prevent an abatement, and to allow the cause to proceed, notwithstanding the death; but not on account of the death. The cause of the action was the injury. And in such cases the action, after the death, is prosecuted for the same cause for which it was brought, and is the same action. In cases where no action is brought by the injured party himself, the statute allows the action to be brought by the representative. This could not have been done at the common law, and it is, therefore, in this sense, a new and statutory action. But it is brought for the same cause as if the injured party had himself brought the action."

Under Lord Campbell's act, as well as the New York act, and acts of other states following the peculiar verbiage of the English

act, "the injury to the deceased was not an element in the damages recoverable, but only the pecuniary loss of the relative entitled to the benefit of the recovery." But under the Tennessee statute the matter was quite different, and in *Trafford v. Express Co.*, cited above, the Tennessee decisions are considered, and the conclusions reached in *Fowlkes v. Railroad Co.*, cited above, reaffirmed, Judge Cooper saying:

"It seems to me clear that the legislature, by the statutory provisions under consideration, intended to abolish the rule of common law touching the abatement of rights of action for personal torts producing death, and to provide that the right of action of the person injured, subject to his control during his life, should survive to his widow and children or personal representatives, as the case may be; and that the only damages that can be recovered in any action under the statutes are the damages which the deceased was entitled to recover if he had sued. In this view the statutory provisions are simply those of the abatement and revivor of the particular class of actions, the recovery, in the event of death of the person injured, without a different valid disposition on his part, being distributable as other personal property of the deceased, free from the claims of creditors. The provisions dovetail exactly into our general system of laws regulating the rights of action of deceased persons. There is no anomaly either in the character of the recovery or in its distribution."

In *Railroad Co. v. Smith*, cited above, the court said:

"It is the same action, whether it be brought by the injured party in person or by his administrator after his death."

Any attentive consideration of the decisions of the Tennessee supreme court prior to the amendment of the act made by chapter 186, act of 1883, being now section 4029, Shannon's Code, as set out above, will make it plain that the damages sustained by those relatives having a pecuniary interest in the life of the deceased were wholly disregarded as an element for consideration in determining the damages recoverable under the act. The effect of the act of 1883 was to enlarge the recovery so as to include therein the pecuniary damage sustained by those for whose benefit the action survived. Two separate actions may at the common law arise from the same injuries,—one in favor of the person injured and the other in favor of the relative having a direct pecuniary interest in the life and services of the injured. Both rights of action were extinguished by the death of the person injured. Now, this act of 1883, instead of allowing the widow and children of the deceased to prosecute a separate action to recover the pecuniary damage peculiar to themselves, enlarged the measure of damages recoverable by the representatives of the deceased so as to permit the recovery in that action of "the damages resulting to the parties for whose use and benefit the right of action survives." The effect of this amendment upon the original action has more than once been before the Tennessee court, and while, in *Railroad Co. v. Pounds*, 11 Lea, 127, it was said that its effect was to create "a new or additional cause of action," yet in subsequent cases the observation was retracted, and the act as amended held not to create a new cause of action, but simply to enlarge the damages recoverable in the action of the deceased or by his representative so as to include as an element the pecuniary loss of those for whom the action survived. *Loague v.*

Railroad, 91 Tenn. 458, 19 S. W. 430; *Holston v. Iron Co.*, 95 Tenn. 521, 32 S. W. 486; *Railroad v. Johnson*, 97 Tenn. 667, 37 S. W. 558; *Whaley v. Catlett*, 103 Tenn. 347, 351, 53 S. W. 131. In *Whaley v. Catlett*, cited above, is found an elaborate and authoritative construction of the act under which the suit is brought, in which the question for decision was whether the statute of limitations of one year barring actions for personal torts was applicable to a suit brought after more than one year by the infant children of the deceased against the wrongdoer. "It is evident," said the court; "that, if the right of action be that of the deceased, and commenced to run when the injury was done, the minority of the beneficiary will not be material, as the statute will continue to run, and will not be suspended during minority; otherwise, if the right of action be an independent one in the minor, not derived from the deceased, the statute would not commence to run during the minority, the cause having arisen while the claimant was a minor." It was held by the whole court that the action was barred. Among other things, Justice Wilkes, a very able and learned judge, who wrote the opinion of the court, said:

"The question narrows itself to this: Is the action which the statute authorizes that of the deceased, or is there under the acts a new, substantive, original cause of action in the widow, children, or next of kin, independent of that existing in and passing from the deceased, though resting upon or growing out of the same injury? In other words, does the deceased's cause of action alone survive, and pass to the parties named, or does the statute create a new cause of action in their behalf and for their benefit? We are of the opinion that a careful reading of the statutes can lead to no other conclusion than that they provide alone for the continued existence and passing of the right of action of the deceased, and not for any new, independent cause of action in his widow, children, or next of kin. Section 4025, Shannon's Code, refers to it as the right of action which the deceased would have had in case death had not ensued, and provides that it shall not abate or be extinguished, but shall pass to his widow, etc. It does not provide for or refer to any new cause of action arising or coming into existence in their favor. It is alone by virtue of these statutes that a right of action exists in the widow, children, or next of kin at all for the unlawful killing of the deceased, and this right exists under the statute not because it arises directly to them, in their own right, but because it passes to them in the right of the deceased."

Although the cause of action is that of the deceased, the damages recoverable being enlarged so as to also include those sustained by the relatives for whom the action is maintained, it is, nevertheless, in a very true sense a statutory action, which would not be maintainable but for the statute. Being, however, the cause of action of the deceased, there can be no recovery unless he himself could have recovered for the injury if the death had not ensued. As said in *Haley v. Railroad Co.*, 7 Baxt. 239-242:

"The deceased's right of action, with all its incidents, passes to the personal representative, and must be treated as if the injured party had brought it."

In accordance with this theory of the nature of the action, the Tennessee supreme court have never drawn any distinction whatever between actions brought by the injured person himself, where death did not ensue, and actions brought by one or the other of the persons authorized by the statute to maintain the suit. The question of what was or what was not negligence, or what was or what was

not the effect of contributory negligence, except in cases arising under the statute prescribing precautions to be observed in the operation of railway trains, and the question of who were or who were not fellow servants within the rule of respondeat superior, have always been, and are now, questions of general law in Tennessee; and, whether the injured person dies from his injuries or not, the liability of the wrongdoer depends upon the same general principles of general, and not local, law.

2. But whether the act be regarded as creating a new cause or right of action or as simply abrogating the common-law rule by which actions for personal injuries are extinguished by death, is of no vital importance, for in neither event has the Tennessee court made the statute the basis of any decision by that court as to the liability of an employer for the injury of one servant through the negligence of another. It is to be particularly noticed that prior to the enactment of the survival statute there had been no decisions of the Tennessee supreme court defining who were or who were not fellow servants, or declaring the circumstances under which an employer is responsible for the negligent injury of one employé by another in the same common service. There is, therefore, no basis for the suggestion that the legislature, when enacting the survival statute, intended to adopt the law as defined and declared by the existing decisions of the Tennessee supreme court as a statutory rule of liability where death resulted from the wrongful act. *Fox v. Sandford*, 4 Sneed, 47, 67 Am. Dec. 587; *Goggin v. Railroad Co.*, Thomp. Tenn. Cas. 142; *Railroad Co. v. Elliott*, 1 Cold. 611, 616, 78 Am. Dec. 506; *Haynes v. Railroad*, 3 Cold. 222; *Railroad Co. v. Carroll*, 6 Heisk. 347; *Railroad Co. v. Bowler*, 9 Heisk. 866; *Railroad Co. v. Wheless*, 10 Lea, 741, 43 Am. Rep. 317; *Railway v. Handman*, 13 Lea, 423; *Bradley v. Railway*, 14 Lea, 374; *Railroad Co. v. Lahr*, 86 Tenn. 340, 6 S. W. 663; *Mining Co. v. Davis*, 90 Tenn. 718, 18 S. W. 387; and numerous other cases. An examination of the cases cited will show that the supreme court of Tennessee has always treated the question of the liability of an employer for an injury sustained by one servant through the negligence of another in the same service as a question of general, and not local, law, and that, while recognizing and enforcing the common-law principle exempting the master from liability to a servant for the negligent conduct of another servant in the same service, it has regarded the principle as not applying when one servant was placed in direct control over another as the representative of the master in the particular matter. In *Railway v. Handman*, cited above, the suit was by an administrator, whose decedent had been a fireman in the employment of the railroad company. It was claimed that the deceased fireman had come to his death by the explosion of a locomotive upon which he was serving as a fireman, caused by the negligence of the engineer upon the same engine. A charge that the company would be liable for the negligent death of a fireman caused by carelessness of the engineer on same engine was held erroneous.

"In this state," said Judge Cooper, speaking for the court, "we have adopted the general rule, established by the authorities, regulating the relative rights

of master and servant. The servant, on entering into service, knows, or is taken to know, that there are extraordinary dangers inseparable from such service, which human care and foresight cannot always guard against. If he voluntarily engages to serve in view of all the hazards to which he will be exposed, it is well settled that, as between himself and his employer, he undertakes to run all the ordinary risks of the service; and this includes the risk of injuries, not only from his own want of skill and care, but likewise the risk of injuries from the negligence of his fellow servants. Per McKinney, J., in *Railroad Co. v. Elliott*, 1 Cold. 611, 616, 78 Am. Dec. 506. The qualifications of the rule—some of them peculiar to this state—need not be particularly noticed, but are illustrated by *Railroad Co. v. Carroll*, 6 Heisk. 347; *Guthrie v. Railroad Co.*, 11 Lea, 372, 47 Am. Rep. 286; *Railroad Co. v. Gurley*, 12 Lea, 46; *Railroad Co. v. Bowler*, 9 Heisk. 866."

After referring to *Fox v. Sandford*, 4 Sneed, 47, 67 Am. Dec. 587, and *Railroad Co. v. Elliott*, 1 Cold. 611, 616, the opinion proceeds as follows:

"These cases not only settle the general principle which regulates the servant's right of recovery against the master, but directly meet the point which has been suggested that the principle does not apply where the injury results from the negligence of a co-servant who is the immediate superior of the injured servant. The 'foreman of the job,' in *Fox v. Sandford*, was the immediate superior of the plaintiff, a hand hired to work on that job. The engineer of the locomotive in the case of *Railroad Co. v. Elliott*, was the immediate superior of the plaintiff, a fireman, or assistant fireman, on the same engine. The mere fact that the negligent servant is, in his grade of employment, superior to the servant injured, does not take the case out of the rule. Nor does the mere fact that the negligent servant is the equal or the inferior in grade of the injured servant. *Ragsdale v. Railroad Co.*, 3 Baxt. 426. They are still fellow servants in the common service, and each must take the risk of the negligence of the other. 2 *Thomp. Neg.* 1026, 1028, 1034. And it has been expressly held by the other courts that an engineer and foreman, who work together at or on the same engine, are fellow servants within the rule. *Jones v. Yeager*, 2 Dill. 64, Fed. Cas. No. 7,510; *Caldwell v. Brown*, 53 Pa. 453. In order to charge the master, the superior servant must so far stand in the place of the master as to be charged, in the particular matter, with the performance of a duty towards the inferior servant, which, under the law, the master owes to such servant. 2 *Thomp. Neg.* 1031. 'In order to recover,' says Judge McFarland, 'the plaintiff must show that his injury resulted from the carelessness or want of skill of some one who, in the particular matter, stands in the place of the master.' *Railroad Co. v. Wheelless*, 10 Lea, 741, 748, 43 Am. Rep. 317. See, also, *Iron Co. v. Dobson*, 7 Lea, 367, the opinion in which is delivered by the same eminent judge. The *Elliott* case, as we have seen, clearly illustrates the distinction between the mere personal negligence of a superior fellow servant and his negligence in a matter in which he stands in the place of the master, who, under the law, owes a duty in the matter to the servant. And another exception to the rule is where the injury to the inferior employer is occasioned by the direct order of the immediate superior in a sudden exigency. This exception is illustrated by the cases of *Railroad Co. v. Bowler*, 9 Heisk. 866, and *Railroad Co. v. Duffield*, 12 Lea, 63, 47 Am. Rep. 319. In the case before us, the engineer gave no order to the intestate, and exercised no authority over him which contributed to the injury. He did not stand in the place of the master, so far as the particular negligence in question was concerned, for the performance of any duty which, under the law, the master was bound to perform for the protection of the servant. He was simply negligent in complying with a rule of the company adopted for his guidance. It was a case of personal negligence, such as the intestate, in accepting his own employment, undertook to risk. Whether the negligence could in any sense be considered a proximate cause of the particular injury, it is necessary to consider."

In *Railroad Co. v. Smith*, referred to above, the suit was for the negligent death of one servant by the alleged negligence of another. The court, among other things, said:

"It has been held by this court that, as between a railroad company and its employes, the former's liability for injuries from the misconduct or negligence of its agent must be determined, not by our statutes, but by common-law principles."

The question as to whether the conductor of a train occupied such a position of responsibility and control over the other members of the crew as to stand as a representative of the company, and not a fellow servant, first came before the supreme court of Tennessee in 1893, in the case of *Railroad Co. v. Spence*, 93 Tenn. 173, 23 S. W. 211, 42 Am. St. Rep. 907. That the relation of fellow servant did not exist was determined, not by reference to any statute, rule, or custom, or usage of a local character, but upon common-law principles. Thus, after stating the general rule of nonliability for the negligent injury of one servant by another in the same common service Justice McAlister proceeds to state the circumstances under which the exemption does not exist. After referring to *Railroad Co. v. Lahr*, 86 Tenn. 340, 6 S. W. 663, and *Mining Co. v. Davis*, 90 Tenn. 718, 18 S. W. 387, he quotes from Judge Cooper in *Railway v. Handman*, 13 Lea, 423, as follows:

"In order to charge the master, the superior servant must so far stand in the place of the master as to be charged in the particular matter with the performance of a duty toward the inferior servant which, under the law, the master owes to such servant."

Applying the principle stated and illustrated in earlier cases to the case in hand and to the duties shown to rest upon a conductor in control of a train, the court reached the conclusion that:

"A conductor placed in charge of a freight train, with authority to direct and control its movements, is a representative of the company, charged with the performance of a duty which the company owes to the public and its employes on the train."

For the particular result the court rests the case upon *Railroad Co. v. Ross*, 112 U. S. 390, 5 Sup. Ct. 184, 28 L. Ed. 787, and *Railroad Co. v. Keary*, 3 Ohio St. 201. Under such circumstances there can be no room for the contention that we are bound to follow the decisions of the supreme court of Tennessee in respect to the question of who are or are not fellow servants, for the basis of those decisions is not a statute, but the general common law.

In *Byrne v. Railroad Co.*, 9 C. C. A. 666, 677, 61 Fed. 605, 24 L. R. A. 693, Judge Taft drew for this court a distinction which is quite obvious. The question there was the liability of a railroad company for the failure to observe a statute of the state regulating the operation of its trains and the effect of the plaintiff's own negligence under that statute in defeating his action. The binding effect of Tennessee decisions in respect to the consequences of contributory negligence upon such actions was under consideration. In respect to this the court, speaking by Judge Taft, said:

"The question whether we are bound by the decisions of the supreme court of the state of Tennessee as to the effect of contributory negligence in

statutory actions depends on the basis given by that court for its conclusion. If the statute is held to be merely declaratory of the common law both in its requirements and in the liability imposed for failure to observe it, and the plea of contributory negligence is allowed only in mitigation of damages, because, in the view of the supreme court of Tennessee, that is the only effect it could have in an action for common-law negligence, we conceive that the effect of contributory negligence in such a case would be a question of general common law, with respect to which we might exercise an independent judgment. But if the rule of the state supreme court grows out of the peculiar liability imposed by the statute as distinguished by that imposed for negligence at common law, then it is the legitimate effect of a construction of a state statute by the highest tribunal of the state, and we are, of course, bound by it."

To the same effect is the later case of *Peck v. Tie Co.* (decided by this court at its June session, and not yet officially reported) 116 Fed. 273.

We can but conclude that the question of the liability of the railroad company for the negligent acts of a conductor of one of its freight trains resulting in the injury and death of a brakeman on the same train is a question of general law, and in no way involved in the interpretation of the statute which preserves the right of action from extinguishment. *Railroad Co. v. Baugh*, 149 U. S. 368, 13 Sup. Ct. 914, 37 L. Ed. 772. The precise question having been decided conversely to the conclusion of the Tennessee court by the supreme court of the United States in *Railroad Co. v. Conroy*, 175 U. S. 323, 20 Sup. Ct. 85, 44 L. Ed. 181, where *Railroad Co. v. Ross*, 112 U. S. 377, 5 Sup. Ct. 184, 28 L. Ed. 787, was overruled, we are under obligation to follow this latter decision as authoritative upon us. The result is that the judgment of the court below must be affirmed.

WASHINGTON IRR. CO. v. KRUTZ et ux.

(Circuit Court of Appeals, Ninth Circuit. October 6, 1902.)

No. 786.

1. CONTRACTS—ILLEGALITY OF CONSIDERATION—SERVICES RENDERED BY PUBLIC OFFICER.

The officers of an irrigation company offered to convey 160 acres of land to the register of a land office in consideration of services rendered by him in the company's behalf with respect to certain lands in dispute before the department. He declined the offer, stating that he could not accept it while an officer, but would do so after his term expired, provided the company would give him some work to do in payment. After the expiration of his term, he rendered nominal services to the company, upon which the offer was renewed and accepted. *Held*, that the latter transaction was so blended with the former and the conditional acceptance of the first offer as to constitute a single transaction, and to render the agreement void and unenforceable in the courts, as against public policy.

2. SAME—NEW CONSIDERATION.

Complainant contracted with the officers of an irrigation company for water rights for a half section of land, in payment for which he was to convey a half section to the company; being credited thereon, however, with a quarter section which such officers had previously agreed to convey to him for an illegal consideration. He purchased the remaining quarter section, and caused the same to be conveyed to the company,

by which it was accepted and retained. *Held*, that such conveyance and acceptance constituted a new and sufficient consideration for the contract, which rendered it valid and enforceable, notwithstanding the illegality of the prior agreement.

3. CORPORATIONS—RATIFICATION OF UNAUTHORIZED CONTRACT.

The acceptance and retention by the irrigation company of the land conveyed to it by complainant, with knowledge of the contract under which the conveyance was made, was a ratification of such contract, even if it was originally made by its officers without authority.

4. SPECIFIC PERFORMANCE—DISCRETION OF COURT.

Specific performance is not a matter of absolute right, but rests entirely within judicial discretion, to be exercised according to settled principles of equity; and the relief will be granted when it is apparent from a view of all the circumstances of the particular case that it will subserve the ends of justice, and will be withheld when from a like view it appears that it will work hardship or injustice to either of the parties.

Appeal from the Circuit Court of the United States for the Southern Division of the District of Washington.

This is a petition praying for the specific performance of a contract for a water right for 320 acres of land. The main suit in which it was presented was entitled "California Safe Deposit & Trust Company v. Yakima Investment Company," for the foreclosure of a mortgage or trust deed securing the issue of about \$700,000 in bonds. Receivers were appointed, decree and order of sale made, and the property mortgaged was sold to J. Dalzell Brown. The sale was confirmed, and Brown sold and transferred the property to the Washington Irrigation Company, appellant herein. The property involved in the foreclosure suit consisted of some 25,000 acres of arid land, and an irrigation canal and laterals covering a large scope of country. When the decree for the foreclosure and sale was entered, the court directed that the sale should be made as a whole of the lands and water system, and of all "contracts, options, and privileges of said Yakima Investment Company and its predecessors in interest, and of the receivers * * * in this suit, to acquire and purchase and to receive conveyances of lands and other property," and including all contracts by the investment company and its predecessors and receivers for the sale of water to other parties. The decree further provided that the purchaser and his successor should take said property subject to all valid existing contracts for the sale of any of the mortgaged lands and for the sale of water from said irrigating canals made by the defendant or the receivers, and jurisdiction of the case was expressly retained by the court for the purpose of enforcing these provisions of the decree. Before the confirmation of the sale the claim of the appellees herein was brought up, and it was stipulated and agreed in open court by the purchaser that their claim should not in any manner be prejudiced by the confirmation, and that, if the claim could not be amicably adjusted, the court expressly retain jurisdiction to hear and determine it.

It appears from the record herein that in 1890 congress passed an act forfeiting to the government every alternate odd section of the granted land held by the Northern Pacific Railroad Company. This act provided that, where the railroad company had previously sold or contracted to sell any of the lands falling within the limits mentioned, it had the privilege of protecting its vendees by surrendering other lands in lieu thereof; and it was required to file proper lists with the land department, showing the facts. About this time the original Sunnyside Canal Company was organized, and the railroad company had contracted to sell it a large acreage lying within the "overlap" of the branch and main lines. At this time Mr. Schulze was the general Western agent of the railroad company, and also president of the canal company. The petitioner Krutz was register of the local land office at North Yakima. In February, 1891, the commissioner of the general land office notified the local land office of the passage of the act of congress here-

¶3. See Corporations, vol. 12, Cent. Dig. § 1714.

inbefore referred to, and inclosed it a list of the lands which the railroad company had elected to take, and instructed the local office as to its course in regard to different matters arising out of the situation. Mr. Krutz knew that the railroad company had contracted to sell lands which were not included in its list, and he notified both the commissioner of the general land office and Mr. Schulze of the information he had, and called attention to the apparent oversight. The result of his action in this regard was the filing of an amended list by the railroad company. In the meantime the register of the local land office had published notice of the status of the land, as directed by the commissioner, and a number of citizens had expressed their purpose to file on the lands on the day that they were to be opened for settlement.

Mr. Krutz, in his own behalf, testified as follows: "About this time it was rumored that the N. P., Yakima & Kittitas Irrigation Company was to construct a large canal covering these lands. The result was that people in great numbers examined the land preparatory to offering to file for it. The railroad company had arranged about this time with the canal company to sell all its odd sections under the canal, including the forfeited sections. It appeared that the land department of the railroad company had been called upon by the commissioner to submit a list of the lands it had sold, embraced in the sections it had elected not to take. Through the carelessness of the railroad company, or Mr. Schulze, its Western land agent, this was not done. Knowing that the railroad company had sold or contracted to sell these lands to the canal company, I wrote a letter on February 18, 1891, to the commissioner of the land office, calling attention to this state of facts. * * * On the same day I wrote a letter to Mr. Schulze, at Tacoma, calling his attention to the same matter. Mr. Schulze was Western land agent of the railroad company, and also president of the canal company. * * * A short time thereafter I received a letter from the department, dated March 5, 1891, instructing me to publish notice of the amendment. * * * Several days before the date fixed for receiving applications to file for the land, Mr. Schulze came over to North Yakima to learn the true status of the lands, as disclosed by our records, and informed me of the dilemma the company was in. He asked me what I thought was the best course to pursue to extricate themselves. * * * I suggested to Mr. Schulze that he prepare and file a list of the lands he had sold to the canal company, and accompanying it with a protest against the acceptance and allowance of filings. I advised him to send these papers by mail to the land office, so that they would be received at the office before 9 o'clock a. m. on the date the land was to be subject to entry, so that they would take precedence over applications presented at the opening of the office. This was done. In the afternoon, before the date fixed for receiving filings, about fifty persons got in line, and remained all night at the land office to secure preference rights to file. At 11 o'clock that night the settlers sent for me to come to the land office to confer with them regarding their applications to file. They had heard the railway company was intending to file a protest against the acceptance of their filings. I explained to them that, if they insisted making their entries, I would issue certificates, and have the receiver give them receipts, or I would simply note the records of the time of their presentation, and if the protest should be filed I would forward the applications with the protest to the department, and recommend that a hearing be had to determine the rights of the respective parties. * * * They were pleased with these suggestions, and the matter was determined that way, and the records were forwarded to the department. * * * In the fall of 1891, and after the various applications and protests had been filed and were pending before the department in Washington, Mr. Schulze and Mr. Granger expressed themselves as being pleased at the turn the matter had taken, and offered to give me 160 acres of land under the canal. I rejected the offer, as I was register and could not accept it; but I told Mr. Schulze, if he could give me any work for the company after my term of office expired, so that I could feel that I had earned the land, I would then accept it. * * * I was out of office when the hearing was had, and the record forwarded to the department. It was found that the showing made

by the company was not sufficient to bear out the company's contention that the land was really sold before the forfeiture act was passed. Mr. Schulze sent for me to come to Tacoma. I went, and, after listening to his statement of the status of the case before the department, I suggested that the general manager of the Northern Pacific Coal Company be sent to Washington City to look after the cases. I advised Mr. Schulze to get relinquishments from the settlers who had made improvements on the lands. Only two of the fifty settlers (George W. Rodman and his son) had built houses on the land. I advised Mr. Schulze to get relinquishments from these parties, and this was done. * * * Mr. Schulze now claimed that I had rendered the services which entitled me to 160 acres of land. I had filed on a desert land claim covering the S. $\frac{1}{2}$ of sec. 10, twp. 10 N., R. 21 E., and arranged with Mr. Schulze for water for the land by giving the company 320 acres, but I was to have credit for the 160 acres I was to receive for my services. In 1892 I conveyed to the company the N. $\frac{1}{2}$ of the N. $\frac{1}{4}$ of sec. 12, twp. 10 N., R. 21 E., for which I paid \$1,000 cash. In 1898 I completed the purchase of the W. $\frac{1}{2}$ of the S. E. $\frac{1}{4}$ of sec. 18, twp. 10, range 21 east, from Eugene G. Kreider and wife, which cost me about \$500. In order to save the trouble of making two deeds, I had Kreider and wife convey this land direct to the canal company. After the lands were sold at foreclosure sale and purchased by the Washington Irrigation Company, that company wanted to get a conveyance direct to it from Kreider; and I had Kreider and wife execute a new deed to that company. Mr. Granger, the manager of the Washington Irrigation Company, had written to Mr. Kreider, asking an explanation of Kreider's original deed to the old canal company, which, it seems, had never been recorded; and, when Kreider sent that letter to me, I wrote to Mr. Granger, explaining that this conveyance was procured by me in completion of the agreement for my water right, and then Mr. Granger requested me to get a new deed from Kreider direct to the Washington Irrigation Company, which I did. * * * These two tracts of land were conveyed by me and by Kreider and wife at my instance, in performance of my agreement to convey to the company 160 acres of land in payment for a water right for my 320 acres of land. No other consideration was paid by the canal company for that 160 acres, either to me or to Kreider. The canal company took possession of the first 80 acres conveyed by me in 1892, and kept possession until it or the receivers sold the land. The company or receivers took possession of the Kreider 80 acres in 1898, after Kreider's first conveyance, and kept possession until the spring of 1901, when the present company sold a part of it. It still has possession of the unsold portion of the land. I informed the receivers, J. S. Allen and George Donald, of the agreement for my water right, and they promised to give me a deed, but they never delivered it. * * * When the canal company went into the hands of the receivers, Mr. Schulze advised me to wait until the company got control of the property, and then we could adjust the matter, but Mr. Schulze killed himself. Mr. Schulze never recorded the deed which I gave the company in 1892, and at the suggestion of the receivers I made another deed of this land to the receivers in May, 1896, which they received, and the greater portion of it was sold by them."

On his cross-examination the following questions and answers were given: "Q. Mr. Krutz, was the contract which you state exists between you and Mr. Schulze oral or in writing? A. It was in writing. He sent a letter. Q. What did you do with that letter? A. I filed the letter with the receivers of the Yakima Investment Company. Q. What search have you made to find that letter? A. I searched among the papers in the office of the receivers, and was unable to find it, and I inquired of the receivers for it, but have been unable to find it."

Walter N. Granger testified on behalf of the Washington Irrigation Company that he was the general superintendent of the Washington Irrigation Company; that he had been connected with the Sunnyside Irrigation Canal from its inception; that "Mr. Schulze was the president of this company, and it had a board of trustees, and I was its vice president and general manager. * * * I am acquainted with the claim for a water right of Ira M. Krutz and wife. Both Mr. Krutz and Mr. Schulze informed me that

Mr. Schulze had promised Mr. Krutz a piece of land near Zillah, consisting of 160 acres, for services which Mr. Krutz had rendered, while register of the land office, for the Northern Pacific Railroad Company, in straightening out the applications of the railroad company as to the forfeited lands. I was not present at any time when Mr. Schulze made any promises to Mr. Krutz to give him land. But at North Yakima Mr. Schulze informed me that he had promised Mr. Krutz a piece of land, and I afterwards had a talk with Mr. Krutz, when he stated to me that Mr. Schulze had promised to give him 160 acres of land near Zillah. * * * I do not think that Mr. Krutz, after he ceased to be register of the land office, performed any services whatever for the irrigation company. * * * As to a water right to Mr. Krutz for 320 acres of land, this was an after consideration, as the first promise to Mr. Krutz was for 160 acres of land near Zillah, without a water right. * * * I never heard anything about a water right for 320 acres until he had filed upon his desert land claim. * * * I got that information from Mr. Krutz. I understood from Mr. Krutz during that time that there was such an understanding with Mr. Schulze, and, when the 80 acres was conveyed to the old canal company by Mr. Krutz, I understood that it was in performance of such an agreement; but I got that understanding from Mr. Krutz, and I never heard Schulze say anything about it."

E. F. Blaine, for appellant.

W. H. Bogle, for appellees.

Before GILBERT and ROSS, Circuit Judges, and HAWLEY, District Judge.

HAWLEY, District Judge, after making the foregoing statement of facts, delivered the opinion of the court.

There are 12 errors assigned on this appeal, which embody, in various forms, the following propositions, viz.: That the services performed by Krutz for Schulze, for which he was to receive 160 acres of land, were rendered to the Northern Pacific Railroad Company, and not to the Yakima & Kittitas Irrigation Company, or its successor in interest; that Paul Schulze had no power to bind the irrigation company to convey to Krutz and wife, petitioners herein, a water right for 320 acres of land; that the receivers of the property of the Yakima Investment Company were without power to adopt or ratify the agreement upon which petitioners rely; that petitioners are in a court of equity with unclean hands, praying specific performance where there is a partial failure of consideration; that the petitioners can be fully compensated in damages; that the evidence failed to show the terms and conditions of the agreement entered into by Paul Schulze for the irrigation company and the petitioner Ira M. Krutz.

The third assignment reads as follows:

"Because the evidence showed that the services rendered by the petitioner Ira M. Krutz, for which he claims 160 acres of land and a water right for 160 acres of land, were services rendered by him while register of the United States land office at North Yakima, Washington, and that said services were a part of his official duties, and that the promise made to compensate him therefor was contrary to public policy and void, and the alleged agreement for a conveyance of a water right for 320 acres of land grew immediately out of said illegal claim, and is contrary to law and invalid."

Appellees herein allege in their petition that they were the owners of the S. ½ of section 10, township 10 N., range 21 E., containing 320 acres, and then allege the facts of the Yakima Improvement

Company's contract with the railroad company for large quantities of land, and aver—

"That doubts having arisen as to the title of said railroad company to said lands under said grant, and the steps that had been taken in pursuance thereto, this petitioner, Ira M. Krutz, at various times assisted in clearing up these clouds upon such titles and in preventing contests, and his assistance in that respect was of great benefit to said irrigation company, and enabled them to obtain a clear title to said lands; that thereafter said Yakima Improvement Company entered into an agreement with these petitioners whereby it contracted to convey to petitioners a good, sufficient, and perpetual water right from its irrigation canal, commonly known as the 'Sunny-side Canal,' for the lands of petitioners hereinabove described, if and whenever petitioners should convey or cause to be conveyed to said company a good title to one hundred and sixty acres of other lands lying under said canal or its laterals, which proposal was accepted by petitioners; that thereafter, said Yakima Improvement Company having become insolvent, under proceedings duly had in this honorable court in the above-entitled cause, J. S. Allen, Geo. Donald, and Paul Schulze were appointed receivers of the property and assets of said company, with authority to operate said property under the directions of this honorable court; that said receivers were fully advised of the terms of said agreement with petitioners, and approved and adopted the same; that afterward, on or about 12th day of May, 1896, these petitioners, in part performance of said contract and agreement, conveyed to said J. S. Allen and Geo. Donald, as such receivers, and for their said trust (the said Schulze having died prior thereto), the north half of the northwest quarter of section 12, township ten north, of range 21 east; that said conveyance was accepted by said receivers for their said trust; that thereupon said receivers prepared and signed a conveyance conveying to these petitioners a water right for their said lands, and filed said conveyance with the papers pertaining to said receivership, to be delivered to these petitioners upon the conveyance to said trust of the additional eighty acres specified in said agreement * * *; that they [petitioners] have fully complied with their said agreement; that said Washington Irrigation Company has received the full benefit thereof; and that petitioners are entitled to a specific performance upon the part of said company."

The answer of appellant denies the various allegations in the petition, and, among other things, avers as an affirmative defense that—
"Believing that the only services which the petitioner Ira M. Krutz had rendered the Yakima Investment Company or its predecessor were rendered by said Krutz while register of the local land office at North Yakima, Washington, and that his claim for compensation therefor was contrary to public policy and void, investigated his said claim, and reached the conclusion that all services performed by said Krutz, and being the services set forth in his said petition, were performed by him while register of said land office, and the same pertained to his duties as such register, and that said Krutz used his official position wrongfully and for private gain, and that the promise and agreement for a water right for 160 acres of land, if any, was founded upon, and immediately grew out of, his wrongful acts as register."

Upon these issues the cause was tried, and decree rendered in favor of petitioners. The record is presented without any bill of exceptions. There is no agreed statement of facts. There is what purports to be a statement of the testimony of witnesses, and of divers documents, exhibits, and letters. But it is not shown that any objections were made or exceptions taken to any part or portion thereof. There is not a single exception to any ruling of the court. Whatever was offered was taken down without any ruling of the court. Everything was admitted without objection. We cannot, therefore, be expected to discuss all the questions argued by counsel.

Were the transactions between the parties which led up to the contract herein sought to be enforced of such a character as to authorize this court to say, as a matter of law, that the contract is void as against public policy, or is the evidence sufficient to make it the duty of this court to declare that the contract, as proven, is valid? It is contended on behalf of appellees that, inasmuch as all the testimony was taken before the court, the decision of the lower court upon the facts is not subject to review. But in reply to this contention it is only necessary to say that the facts as to all of the transactions between the parties, upon the point mentioned, is undisputed. There is no conflict in the evidence upon any material point. The main question presented is a legal one, to be determined upon the undisputed facts.

It must be admitted that, if Krutz had accepted the offer of Schulze while he was in office, the bribery of the one and corruption of the other could not be questioned. Such a contract would be *contra bonos mores*, and could not be enforced in a court of justice. But Krutz did not accept the offer. He refused it, accompanying the refusal with the statement that he could not accept it while he was in office, but that his term of office would soon expire, and if the railroad company would then give him something to do, so that he could feel that he had earned the 160 acres of land, he would then accept the offer. The services rendered by petitioner to the railroad company at the request of Schulze after he went out of office were, in our opinion, purely nominal, and were so blended with the original offer made by Schulze, and conditional acceptance by Krutz, as to make it but one transaction; and if the case rested alone on such services, in connection with the manner of the original offer, it would unquestionably be the duty of a court of equity to put its seal of condemnation on the whole transaction, and dismiss a bill brought to enforce such a contract.

As register of the land office, Krutz was, as he states in his testimony, frequently called upon to give advice to people as to the manner of selecting and locating public lands, etc. It was his duty to inform such parties of the methods and procedure to be pursued in such matters, but he had no right to go outside of his legitimate duties in this respect, and become the partisan adviser of one applicant, and point out to him a course to be pursued whereby he could obtain a preference over others, to their prejudice and detriment. The action of a public officer should always be guided and controlled only by considerations of the public welfare, and a desire faithfully, honestly, and impartially to perform his official duties; and any action taken by him outside of his official duties, which tends to substitute for those considerations others, which are based upon illegal grounds, is clearly opposed to public policy and void. This principle is too well settled to require the citation of any authorities.

It is unnecessary to criticise the action of Mr. Krutz in regard to his conditional acceptance of the offer. He may have been actuated by good motives, without any intent to do wrong; and he may have thought that by the services he subsequently rendered he had justly earned the fee which entitled him to then accept a deed, as previously

offered by Schulze. But it is impossible to separate the services from the original offer, so as to make the last valid if the first was void. The services rendered by Krutz after he went out of office are so blended with the original promise and conditional acceptance as to make the whole a unit and indivisible. That which is bad destroys that which is good, and they perish together.

It is the duty of courts to carefully scrutinize contracts of this general character, and to condemn the very appearance of evil, as the tendency of such contracts is to lead to the encouragement of wrongdoing. Hence the relief asked for in such cases should not be granted. This result follows "without reference to the question whether improper means are contemplated or used in their execution. The law looks to the general tendency of such agreements, and it closes the door to temptation by refusing them recognition in any of the courts of the country." *Tool Co. v. Norris*, 2 Wall. 45, 56, 17 L. Ed. 868; *Trist v. Child*, 21 Wall. 441, 452, 22 L. Ed. 623; *Meguire v. Corwine*, 101 U. S. 108, 111, 25 L. Ed. 899; *Oscanyan v. Arms Co.*, 103 U. S. 261, 275, 26 L. Ed. 539.

The argument of appellant's counsel is principally based upon the grounds we have discussed, and we have therefore deemed it proper to express our views in regard thereto. If the appellees were seeking any relief against the railroad company, based alone upon the promise of Schulze, as its agent, to convey 160 acres of land to Krutz in consideration of the services he had rendered to the railroad company, we would have no hesitation whatever in declaring that the contract between them could not be enforced in a court of equity. But the contract set forth in the petition was not made with the railroad company. It is not a party to these proceedings. The petitioners ask no relief against it. It is true that Paul Schulze advised, directed, and controlled the whole business. He was the guiding spirit in all of the transactions. But the contract herein sought to be enforced is a new contract, different in its nature, terms, and conditions from the contract which the railroad company made with Krutz, and it is based upon other considerations, and made long after Krutz went out of office. This contract calls for a water right for 320 acres of land, to secure which Krutz was required to convey to the water company 160 acres of land, which he did at the times and in the manner stated in the statement of facts. The record shows that the deeds to 160 acres of land were accepted by the water company, and that it sold a greater portion thereof, and appropriated the proceeds to its own use. For this reason it is not in a position to claim that Schulze, as president of the water company, or as receiver thereof, had no authority to make the contract. The corporation could not accept the conveyance for the land upon which the consideration of the contract was based, and then deny the authority of its president to enter into the contract. The record also shows that Mr. Granger, the general superintendent of appellant, knew that the lands conveyed by Krutz, as above stated, were in performance of his contract for a water right for his 320 acres of land. It also shows that Allen and Donald, the receivers, received the conveyance from Krutz of 80 acres of land with the knowledge that it was delivered in pursuance of the contract in question. It is

further shown that they prepared a deed conveying the water right for 320 acres to Krutz, but for some unexplained reason it was not delivered. Subsequently they notified Krutz that he would have to apply to the court for relief. Can it, in the light of these facts, be legally said that this new contract grew immediately out of the illegal contract made by Krutz with the railroad company? We think not. It is true that it was made with full knowledge of the prior agreement, and that it had a remote relation thereto, in this: that the occasion for making the new contract arose out of the existence of the prior illegal act. But this fact alone does not make it void. In *Armstrong v. Toler*, 11 *Wheat.* 258, 269, 6 *L. Ed.* 468, where the principles we have announced as to the invalidity of the prior agreement are clearly recognized, Marshall, C. J., speaking for the court, said, "A new contract, founded on a new consideration, although in relation to property respecting which there had been unlawful transactions between the parties, is not itself unlawful." He points out the various distinctions that should always be drawn with reference to the different kinds of contracts, and cites several authorities to show that on a new contract, by which money is advanced at the request of another, or there is an express promise to pay, an action may be sustained, although the money was advanced to satisfy an illegal claim. This distinction is founded on the ground that the money lent would constitute a new consideration, and be the foundation of a new contract, which could not be vitiated by a knowledge of the purpose for which the money was lent. We are of opinion that the principles announced in that case, and followed in many others of like import, are applicable to the facts in the present case. Moreover, whatever view might be taken of the relation which the illegal contract bears to the new contract, the appellant ought not to be permitted to refuse to perform this contract without first returning to Krutz the lands, or the full value thereof,—the fruits and advantages it had received. Its offer to pay him \$400 for the 80 acres of land it had received from Kreider at Krutz's request is not such an offer as the law requires. It would be an act not only of hardship, but of apparent injustice, to deny specific performance herein, under all the circumstances, and compel Krutz to bring a suit against appellant for damages for its failure to return the property. Ordinarily the law leaves to parties the right to make such contracts as they please, demanding, however, that they shall not require either party to do an illegal thing, and that they shall not be against public policy or in restraint of trade. *Manufacturing Co. v. Gormully*, 144 *U. S.* 224, 233, 12 *Sup. Ct.* 632, 36 *L. Ed.* 414. But specific performance is not a matter of absolute right. It rests entirely within judicial discretion, to be exercised according to the settled principles of equity, so as to reach the ends of justice and of right. *Snow v. Nelson* (C. C.) 113 *Fed.* 353, 356; *Newton v. Wooley* (C. C.) 105 *Fed.* 541, 544; 20 *Enc. Pl. & Prac.* 392, and authorities there cited. No positive rule can be laid down by which the action of the court can be determined in all cases. In general it may be said, as was stated in *Willard v. Tayloe*, 8 *Wall.* 557, 567, 19 *L. Ed.* 501, "that the specific relief will be granted when it is apparent, from a view of all the circumstances of the particular case, that it will subserve the ends of jus-

tice, and that it will be withheld when, from a like view, it appears that it will produce hardship or injustice to either of the parties. It is not sufficient, as shown by the cases cited, to call forth the equitable interposition of the court, that the legal obligation under the contract to do the specific thing desired may be perfect. It must also appear that the specific enforcement will work no hardship or injustice." See, also, *Nickerson v. Nickerson*, 127 U. S. 668, 675, 8 Sup. Ct. 1355, 32 L. Ed. 314; *Hennessy v. Woolworth*, 128 U. S. 438, 442, 9 Sup. Ct. 109, 32 L. Ed. 500; *Dent v. Ferguson*, 132 U. S. 50, 67, 10 Sup. Ct. 13, 33 L. Ed. 242.

Without further discussion, our conclusion upon the whole case is that the new agreement made by Schulze, as president of the water company, with Krutz, for the conveyance of the water right for 320 acres of land, is, under all the facts considered herein, a valid one, and that the ends of justice would be subserved by its enforcement.

The decree of the circuit court is affirmed, with costs.

NORTHERN PAC. RY. CO. v. TYNAN.

(Circuit Court of Appeals, Ninth Circuit. October 6, 1902.)

No. 790.

1. MASTER AND SERVANT—DEFECTIVE RAILROAD CARS—ASSUMED RISK.

It is the duty of a railroad company, which it owes to its employé as well as to the public, to use reasonable care to see that the cars used on its road are in good order and fit for the purposes for which they are intended; and an employé has the right to rely upon the performance of this duty, and does not assume the risk arising from the company's neglect to perform it.

2. SAME—CONTRIBUTORY NEGLIGENCE—COUPLING CARS.

The burden of proving contributory negligence of an employé, to defeat recovery for his injury, rests on the master; and it must be shown not only that he was negligent, but that his negligence caused or contributed to the injury. The fact that a brakeman, killed while attempting to couple cars on a side track which was on a curve, was working from the inside of the curve, does not warrant an instruction that he was guilty of negligence, as a matter of law,—much less, that he was guilty of contributory negligence,—where there was evidence that, with the cars to be coupled, there was as little danger on the inside as on the outside.

5. SAME—ACTION FOR DEATH OF BRAKEMAN—QUESTION FOR JURY.

Plaintiff's intestate, while employed as a brakeman by defendant railroad company, was killed while attempting to couple two cars on a side track. One of the cars was equipped with an old-style Miller hook coupler. It was little used, and when used was coupled to cars having link and pin couplers; but it was not blocked to hold the hook in position, as customary when such cars are so used, and was old and not in good repair. The other car had also an old-style skeleton link and pin coupler, not generally in use, and the coupling between the two was more than usually dangerous. Deceased was not instructed as to the kind of couplers, and, so far as appeared, did not know the kind in use on such cars. *Held*, that defendant was negligent in the use of such appliances, and that, in the absence of conclusive proof of contributory negligence, the court properly refused to direct a verdict for defendant.

¶ 1. See *Master and Servant*, vol. 34, Cent. Dig. § 554.

4. APPEAL—REVIEW—REFUSAL OF INSTRUCTION.

A judgment will not be reversed on appeal because of the refusal of instructions requested, where the record does not contain the entire charge given.

In Error to the Circuit Court of the United States for the District of Oregon.

To clearly understand the contentions of the respective parties, and the opinion of the court, it is essential to outline the substance of the testimony given at the trial. The testimony shows that the deceased went to work for the railway company as brakeman on its Burke-Wallace Branch about three weeks prior to his death; that he was a competent, skillful brakeman; that the train crew consisted of Chattin, as conductor, the deceased, and Chester, as brakeman; that on the morning of March 13, 1899, deceased and Chester were, pursuant to Chattin's orders, engaged in the Wallace yards in making up the train that was to leave for Burke; that Chattin told them to get a certain box car off of a yard track called the "Nine-Mile Track," and put it in the train behind coach 417, which was the passenger coach regularly used on that run; that in front of said box car on the nine-mile track was coach 645; another coach was standing on the adjoining house track; to get said box car in its proper place in the train, deceased and Chester had to first move the coach on the house track, to throw the switch, and get in over the frog to the nine-mile track, and then couple onto and move coach 645; that deceased and Chester were doing the coupling and switching and braking required in the making up of the train; that Chattin did not get over to where they had been working until after the deceased was injured, and just as he died; that deceased and Chester were proceeding in the right way to get said box car, when, in the act of coupling coach 417 onto coach 645, for the purpose of moving the latter and getting at the box car, deceased was injured; that, immediately before and at the time of the injury, Chester was on top of the box car for the purpose of letting off the brake thereon, and said brake was not to be let off, nor Chester leave the top of the box car, until deceased had coupled 417 to 645, and also coupled the other end of 645 to the box car, and then Chester was to release the brakes on the box car; that the coupler on the end of 417 was a skeleton drawbar, made of malleable iron, and riveted together; this skeleton draw bar was an old-style link and pin coupler, the first one that was ever gotten out, and was unhandy and dangerous, and, in making a coupling between it and any other coupler, a link and two pins would have to be used; that this skeleton drawbar on 417 was different from, and more dangerous and inconvenient to use than, the ordinary style of skeleton drawbars; that 645 was an extra coach, not used regularly; that it was equipped with Miller hooks on both ends: that it was the only car used on the Burke Branch that was equipped with Miller hooks; that the Miller hook was an old-style coupler, designed and intended for passenger coaches, to be used automatically with another Miller hook, and at the time of the injury was not in general use; that more modern automatic couplers had been in general and successful use on both passenger coaches and on freight cars for some time before the deceased was injured; that the head of the Miller hook is hook-shaped; that the coupler has a long shank, which sets, and has considerable play and lateral motion in a carrying iron; that this play and motion allow the sloping sides of the heads, as two Miller hooks come together, to slip by each other until the hooks pass, when, by the action of a large heavy spring back of the carrying iron, the hooks are forced and grip together, and thus an automatic coupling is effected; that a Miller hook will only couple automatically with another Miller hook; that, to couple it to anything else, a link and pin must be used; that a coupling between a Miller hook and a skeleton drawbar is the most dangerous and difficult coupling known to trainmen; that a coupling could be much more easily effected between a Miller hook and skeleton drawbar of the ordinary style than between the particular Miller hook and the particular skeleton drawbar that were actually used on coaches 645 and 417; that the employés on the

Wallace-Burke Branch had, prior to the employment of deceased, complained to the railway officers of the danger of making couplings between Miller hooks and skeleton drawbars, and had requested the removal of the objectionable equipment; that the lateral motion of the Miller hooks could be prevented by putting blocks and wedges in the carrying iron or stirrup that holds the Miller hook; that when thus blocked the space where the Miller hook would otherwise move from side to side in the carrying iron is filled in with the block that is strapped or bolted there, which prevents the Miller hook from shoving over; that it was customary and usual to block Miller hooks when they were habitually used in making link and pin couplings; that the Miller hook on 645 was not blocked in any way, and was used in nothing but link and pin coupling; that in the ordinary performance of the duty of coupling cars a brakeman could not observe whether or not a Miller hook was blocked; that, owing to the infrequent use of 645, the train crew were seldom called on to make a coupling between a Miller hook and skeleton drawbar, and deceased had not attempted, so far as known, to make such a coupling during his employment by the railway company; that deceased was never warned by defendant, or any of its officers or employés, of the danger of making a coupling between a Miller hook and skeleton drawbar; that the proper and the safest way to make the coupling between the Miller hook on 645 and skeleton drawbar on 417 was to first put the link in the skeleton drawbar (417 being the moving car), and then guide such link by hand into the Miller hook on 645; that deceased had endeavored to make the coupling in that way; that an examination made immediately after the injury disclosed the fact that the ends or heads of the two couplers had slipped by each other so that the Miller hook was slipped in behind the lip of the skeleton drawbar, thereby allowing the platforms of the two coaches to come much closer together than they should come; that attached to the platforms of 417 and 645 were iron buffer plates, with springs attached to the back thereof, the object and purpose of which was to take up the slack and prevent the cars coming together with a jar; that the buffers were not designed or intended to keep the couplers far enough apart to prevent a man who was coupling them together from being squeezed to death; that there were no bumpers or deadwood or anything else on said coaches which would prevent such a result, or which would, in the event of the couplers passing each other, keep the platforms further apart than the thickness of those bumpers,—about three inches; that the coaches were on a curve at the time of the injury; that deceased was making the coupling from the inside of the curve; that an ordinary link and pin coupling can be made as easily and safely on a curve as on a tangent; that cars on a curve are ordinarily and generally coupled from the inside of the curve, because ordinarily the trainmen cannot get from the outside, and can from the inside, see and give signals to the engine; that the coupling between 417 and 645, which deceased was making, could be as safely made from the inside as from the outside of the curve; that deceased was compelled to make the particular coupling from the inside of the curve, because he could not signal the engineer from the outside of the curve, for two reasons, namely, (1) the cars and train which they were making up, stood in the way, and (2) cars on the house track, which was next to the nine-mile track on the outer side of the curve, stood so close to the nine-mile track at the place of coupling that the deceased could not get far enough away from such outer side; that it was not practicable to make a coupling between the Miller hook and skeleton drawbar with a stick or knife or coupling pin; that the railway company's rule that requires couplings to be so made was universally disregarded, and no attempt was ever made by the railway company to enforce it.

B. S. Grosscup and Jas. F. McElroy, for plaintiff in error.

Arthur C. Spencer, Dan J. Malarkey, and Carey & Mays, for defendant in error.

Before GILBERT and ROSS, Circuit Judges, and HAWLEY, District Judge.

HAWLEY, District Judge, after making the foregoing statement, delivered the opinion of the court.

This action was brought by the administrator of the estate of John Tynan, deceased, under the provisions of the Revised Statutes of Idaho of 1887 (section 4100), to recover damages for the death of John Tynan, which occurred while he was employed as a brakeman by the railway company, and engaged in attempting to couple two of its cars. The coupler on one of the cars was a Miller hook, and the coupler on the other was a skeleton drawbar. It is alleged in the amended complaint that both couplers were old, and not adapted to each other or fit for use; that they were faulty in construction, out of repair, and did not couple automatically by impact; that there were no bumpers or deadwoods or other contrivance on the end of the cars to prevent the platforms on each car coming together in case the couplers passed each other in attempting to effect a coupling; that the Miller hook was not blocked, adjusted, or fixed so as to prevent or reduce the lateral motion thereof in an attempt to couple it with a skeleton drawbar; that the railway company failed to warn the deceased of the faulty condition and character of the coupler, and of the danger that would accompany the act of making the coupling. The answer denies these allegations of the complaint, and, for affirmative defense, alleges that when the deceased applied to it for employment he was furnished with a book of rules for the guidance of its employes, and that rule 25 provided that, before making a coupling, employes should take time to examine and ascertain the style and condition of the coupling to be made, and notified them that couplings cannot be uniform in style, size, or strength; that the deceased at the time of his employment represented that he had nine years' experience in the railroad service, and promised that he would comply with the rules and regulations of the company, and would discharge the duties of his employment, and assume the risks thereof; that the deceased was guilty of neglect in making the coupling from the inside instead of the outside of the curve; that the deceased was guilty of negligence in making the coupling by placing the link in the skeleton drawbar instead of in the Miller hook; that the cars were used solely upon the Burke Branch, within the state of Idaho, and were not used in interstate commerce. Upon these issues the cause was tried before a jury, resulting in a verdict and judgment in favor of the defendant in error.

The principal error assigned is that the court erred in refusing to give the following instruction:

"I instruct you, gentlemen of the jury, that it will be your duty, under the evidence in this case, and the law governing the same, to return a verdict for the defendant, and I hereby so direct you to do."

A careful reading of the entire testimony contained in the record, a portion of which is embodied in the foregoing statement of facts, has convinced us that the court did not err in refusing to give this instruction.

On March 2, 1893, congress passed "An act to promote the safety of employees and travelers upon railroads by compelling common carriers engaged in interstate commerce to equip their cars with automatic couplers and continuous brakes." 27 Stat. 531 [U. S.

Comp. St. 1901, p. 3174]. This act has no special bearing on this case, except in so far as it suggests the reasons that led to its adoption. It is wholly immaterial whether the railway company was or was not engaged in the use of the cars in question in the business of interstate commerce, and we shall not discuss that question. Prior to the passage of this act there had been numerous decisions rendered by the courts of this country wherein it was held that the railroad companies were guilty of negligence in using the Miller coupler in connection with the ordinary link and pin drawbars. *Russell v. Railway Co.*, 32 Minn. 230, 233, 20 N. W. 147; *Hungerford v. Railway Co.*, 41 Minn. 444, 43 N. W. 324; *Railway Co. v. Garrett*, 73 Tex. 262, 13 S. W. 62, 15 Am. St. Rep. 781; *Martin v. Railway Co.*, 94 Cal. 326, 329, 29 Pac. 645; *Southern Pac. Co. v. Burke*, 9 C. C. A. 229, 60 Fed. 704; *Smith v. Railway Co.*, 72 Hun, 545, 25 N. Y. Supp. 638. These cases are all directly in point in favor of the ruling of the court below. But the present case is much stronger in its facts than in any of the cases cited, in this: that in the present case it is shown that there was no blocking, and that the couplings on each of the cars were old and particularly dangerous, even of their kind. The facts in the case of *Railway Co. v. Archibald*, 170 U. S. 665, 666, 18 Sup. Ct. 777, 42 L. Ed. 1188, closely resemble the facts in this case. It was there held that it is the duty of a railroad company to use reasonable care to see that the cars employed on its road, both those which it owns and those which it receives from other roads, are in good order and fit for the purposes for which they are intended, and this duty it owes to its employes as well as to the public; that an employe of a railroad company has a right to rely upon this duty being performed, and, while in entering the employment he assumes the ordinary risks incident to the business, he does not assume the risk arising from his employer's neglect to perform the duties owing to him with respect to the appliances furnished.

In the light of the testimony and of these decisions (many others might be cited to the same effect), the contention of the plaintiff in error that it had used ordinary and reasonable care in procuring and using proper and safe appliances for the coupling of its cars, and that its employe John Tynan, deceased, had assumed all the risks, and was himself guilty of contributory negligence, does not specially commend itself to the favorable consideration of this court. *Kohn v. McNulta*, 147 U. S. 238, 13 Sup. Ct. 298, 37 L. Ed. 150, and *Southern Pac. Co. v. Seley*, 152 U. S. 145, 154, 14 Sup. Ct. 530, 38 L. Ed. 391, upon which the plaintiff in error relies, are readily distinguishable in their facts from the case at bar. The party injured had in the one case seen and coupled the cars there used, and in the other well knew of the dangerous appliances, without complaining of their use. In neither case was it pretended that the appliances were out of repair, or in a defective condition, old, or unfit for use. Every case depends upon its own peculiar facts. The burden of proving contributory negligence on the part of the employe is always cast upon the railroad company, and the general rule is that it must not only appear that the employe was negligent, but it must also be shown that his negligence contributed to the injury. *Coasting Co. v. Tolson*, 139 U. S. 551, 557, 11 Sup. Ct. 653,

35 L. Ed. 270, and authorities there cited; *Railway Co. v. Volk*, 151 U. S. 73, 77, 14 Sup. Ct. 239, 38 L. Ed. 78.

Considerable stress is laid by the plaintiff in error upon the fact that the deceased was negligent in attempting to make the coupling from the inside of the curve. It is always easy to say that the injury which occurred might not have happened if the injured party had been on the other side or had used other methods in trying to make the coupling. But the question to be determined is whether or not he was guilty of negligence in attempting to make the coupling at the place, in the manner and under the circumstances shown by the testimony. There was testimony in this case tending to show that the coupling could have been made, while the cars were on the curve, with as little danger on the inside as on the outside. The reason why it was attempted on the inside is shown by the existence of obstructions which prevented the deceased from signaling the engineer on that side when the coupling was made, which was a part of his duty. In *Bucklew v. Railway Co.*, 64 Iowa, 603, 609, 21 N. W. 103, the court said:

"The engineer occupies one side of the locomotive, and the fireman the other. The usual position of an employé desiring to make a signal for the purpose of controlling the movements of a train, when not on a curve, is on the engineer's side. In the present case the plaintiff was on the fireman's side when he gave the signal to stop the train. It is claimed the plaintiff cannot recover because he was not in his proper place. But there was evidence tending to show that, immediately prior to the time the signal was given, the train passed over a curve in the track, and that a signal given while the train was so passing from the engineer's side could not have been seen by him. Now, conceding that the train had passed a short distance beyond the curve, we cannot say that the plaintiff was negligent in not more promptly passing to the other side of the train before giving the signal."

But in any event the question of contributory negligence under the testimony, including rule 25 of the railway company, was one of fact, for the jury to determine. The law is well settled that no case should ever be withdrawn from the jury unless the conclusion necessarily follows, as a matter of law, that no recovery could be had upon any view which can properly be taken of the facts which the evidence tends to establish. *Railroad Co. v. McDade*, 135 U. S. 554, 571, 10 Sup. Ct. 1044, 34 L. Ed. 235; *Railway Co. v. Ives*, 144 U. S. 408, 417, 12 Sup. Ct. 679, 36 L. Ed. 485, and authorities there cited; *Railway Co. v. Cox*, 145 U. S. 593, 606, 12 Sup. Ct. 905, 36 L. Ed. 829; *Gardner v. Railroad Co.*, 150 U. S. 349, 361, 14 Sup. Ct. 140, 37 L. Ed. 1107.

The other errors assigned relate to the refusal of the court to give instructions to the jury as requested by the railway company. We shall not review these instructions, because it would be impossible, in the absence of the whole charge, to decide whether or not the court erred in refusing to give any of the requested instructions. The record does not contain the entire charge of the court to the jury. It does show that the railway company took exceptions to two points that were contained in the charge, and that upon both of these points the exceptions of the railway company were allowed by the court. For aught that appears from the record, the court, of its own motion, may have properly instructed the jury upon all the points sought to be raised by the assignments of error. When the entire charge is not

given in the record, it is the duty of the appellate courts to presume that the requested instructions were refused because substantially given in the general charge. *Scaife v. Land Co.*, 33 C. C. A. 47, 90 Fed. 238, 246; *Case v. Hall*, 36 C. C. A. 259, 94 Fed. 300, 302; *Myers v. Sternheim*, 38 C. C. A. 345, 97 Fed. 625; *Railway Co. v. Wineland*, 42 C. C. A. 588, 102 Fed. 673, 676; *Insurance Co. v. Payne*, 45 C. C. A. 193, 105 Fed. 172, 176; *Reagan v. Aiken*, 138 U. S. 109, 113, 11 Sup. Ct. 283, 34 L. Ed. 892; *Andrews v. U. S.*, 162 U. S. 420, 424, 16 Sup. Ct. 798, 40 L. Ed. 1023.

In *Myers v. Sternheim*, supra, this court said:

"The only other point relied upon by the plaintiff in error arose out of exceptions to the charge of the court, but a reference to the record shows affirmatively that the plaintiff in error has brought up only a part of the court's charge, and there is nothing to indicate that the omitted portion had no bearing upon the point made. Under such circumstances, we would not be justified in reversing the judgment, even if, in the portion of the charge brought here, error appeared, since, in the portions of the charge omitted, the error, if any, may have been corrected."

The judgment of the circuit court is affirmed, with interest and costs.

NATIONAL TEL. NEWS CO. et al. v. WESTERN UNION TEL. CO.

(Circuit Court of Appeals, Seventh Circuit. October 28, 1902.)

No. 789.

1. LITERARY PROPERTY—MATTER SUBJECT TO COPYRIGHT—TELEGRAPHIC QUOTATIONS.

The matter gathered and transmitted by a telegraph company, and printed on a tape by tickers in the offices of its customers, consisting merely of a notation of current events, such as market quotations or the result of a race or game, and having only a transient value, due solely to its quick transmission and distribution, is not copyrightable as literary property, under the constitution and statutes of the United States, but is essentially a commercial product.

2. UNFAIR COMPETITION—TELEGRAPH COMPANIES—COPYING OF MARKET QUOTATIONS.

The gathering of news and its transmission by telegraph is a legitimate business enterprise, carried on through the joint agency of capital and business ability, and as such is entitled to protection, in all its branches, from unfair competition, on the principle which governs courts of equity in granting relief against infringement of common-law trade-marks; and a company engaged in such business, which gathers at its own cost, and distributes to its customers by means of special wires and tickers, news in which they have a peculiar interest, and for which they pay, such as market quotations,—the value of the business to the company depending upon its ability, through the facilities it has created, by the expenditure of money, to furnish such news immediately after the occurrences noted,—cannot be said to have thereby published such news, in such sense as to entitle a competitor to copy the same from a customer's tape as fast as received, and distribute it to its own patrons.

Appeal from the Circuit Court of the United States for the Northern Division of the Northern District of Illinois.

¶ 1. Matter subject to copyright, see note to *Drill Co. v. Mullen*, 27 C. C. A. 248.

¶ 2. Unfair competition, see notes to *Scheuer v. Muller*, 20 C. C. A. 165; *Lare v. Harper & Bros.*, 30 C. C. A. 376.

The bill in the Circuit Court was by appellee, a corporation of New York, against the appellants, The National Telegraph News Company, a corporation of Illinois, and F. E. Crawford and A. K. Brown, citizens of Illinois; and the appeal is from an interlocutory order restraining the appellants, and each of them, their servants, agents and employés, from copying from the appellee's electrical instruments and printing machines, known as tickers, for the purpose of publishing, selling or transmitting through their own tickers, or otherwise disposing of, or using, any of the news or information—such as base-ball, foot-ball, racing, athletics, stock, grain and produce quotations, financial and other reports—which may thereafter be collected, formulated and transmitted by the appellee through its tickers; and from publishing, selling or using the matter so copied until the lapse of fully sixty minutes from the time such news items are printed by appellee's tickers.

The further facts appear in the opinion of the court.

Thomas S. Chadbourne and Charles S. Holt, for appellants.

H. D. Estabrook, for appellee.

Before JENKINS and GROSSCUP, Circuit Judges, and BUNN, District Judge.

GROSSCUP, Circuit Judge, delivered the opinion of the Court:

The appellee, the Western Union Telegraph Company, does a general telegraphing business, having offices in every state, village, hamlet and railroad station in the country, and wires connecting the same with central offices through the country.

About 1881 there was invented an instrument which, by means of a type wheel, actuated by electrical impulse, automatically prints in plain, ordinary type, upon a strip of paper, messages transmitted electrically from a distance. The instrument is now generally known as the "ticker," and is commonly found in the offices of brokers, bankers and other persons interested in the current price of securities, and in hotels, saloons and other places where people, who are interested in the happenings of the race tracks, athletic clubs, base-ball associations, and in pending events generally, are in the habit of gathering. Upon the perfecting of this instrument appellee entered, in addition to its general telegraph business, upon a business heretofore new to it. It collected at various points, where it had offices, news relating to events there transpiring, and, after accumulating in its central offices such product by means of its wires, re-distributed to its tickers, in the offices and places of its patrons, by means of local wires, what was deemed of sufficient interest. The news thus gathered and printed upon strips of paper is open to the inspection of all persons who may come within these places.

The appellants, The National Telegraph News Company, and F. E. Crawford and A. K. Brown, its officers, own and control within the city of Chicago, a system of wires, connecting their operating office with tickers of their own, in the offices and places of patrons of their own. The evidence in the record before us shows that they have been appropriating *vi et armis* the news appearing upon the appellee's tape; and thereupon, with the loss of a few moments only, redistributing such news over their own wires and tickers to their own patrons. Such appropriation is not denied; but is defended as appellants' lawful right, upon the ground, chiefly, that upon the appearance of the printed tape upon the appellee's tickers, in the places

of appellee's patrons, there is such a publication as, within the meaning of the law, dedicates the contents of the tape to the public, and deprives appellee of any further monopoly therein.

The contention is grounded, chiefly, upon the assumption that the matter thus printed is, unless the subject-matter of copyright, unprotected against appropriation by the public; and, if the subject-matter of copyright, comes under section 4956 of the Revised Statutes [U. S. Comp. St. 1901, p. 3407], which provides that no person shall be entitled to a copyright unless he shall, before publication, deliver at the office of the librarian of Congress, or deposit in the mail addressed to the librarian of Congress at Washington, a printed copy of the title of the book, or other article, or a description of the painting, drawing, chromo, statue, statuary, or a model or design for a work of the fine arts, for which he desires copyright.

It is obvious, at a single glance, that the appellee is at great expense in gathering and transmitting the news, and in maintaining the instrumentalities, the offices, and the wires, through which its work, in this respect, is accomplished. At every initial point there must be one who is on the look-out—eyes trained to see, and a judgment trained to discriminate—and in every central office there must be minds fitted by native wit and acquired knowledge to winnow the wheat from the chaff. Added to this is the increased cost of dispatchers, instruments, wires and plant made necessary by this special department of appellee's business.

It is obvious, also, that if appellants may lawfully appropriate the product thus expensively put upon the appellee's tape, and distribute the same instantaneously to their own patrons, as their own product, thus escaping any expense of collection, but one result could follow—the gathering and distributing of news, as a business enterprise, would cease altogether. Appellee could not, in the nature of things, procure copyright under the Act of Congress upon its printed tape; and it could not, against such unfair conditions, without some measure of protection, compete with appellants upon prices to be charged their respective patrons. And in the withdrawal of appellee from this business, there would come death to the business of appellants as well; for without the use of appellee's tape, appellants would have nothing to distribute. The parasite that killed, would itself be killed, and the public would be left without any service at any price.

The general question raised by appellants' contention, then, is this: Is the printed tape, coming out of appellee's tickers, a book or article within the meaning of the copyright laws of the United States, and especially of section 4956 [U. S. Comp. St. 1901, p. 3407], and if not a book or article within the meaning of the copyright law, is there any remedy that will protect this feature of appellee's business against the kind of piracy shown?

We are of the opinion that the printed tape would not be copyrightable, even if the practical difficulties were out of the way. When the federal constitution was adopted the right of property in literary production had been already securely established in English law. Its source, whether in natural right, or in the statute of Anne, was

still in doubt; but that an author had ownership of some species over the production of his brain—an ownership as distinctive as that of the creator of corporeal property—was conceded by all. Indeed, it could not be otherwise in a civil polity that recognizes the individual, and his right to enjoy what he creates, as the unit of organized society.

But when the federal constitution was adopted, the application of this right to productions other than those strictly literary had not yet been mooted. The great case of *Donaldson v. Beckett*, 2 Brown, Parl. Cas. 129, had been decided only thirteen years previously. The business world, that in this day permits nothing to escape as a means for its exploitation had not yet pressed into her service art and books. Business catalogues, circulars containing market quotations, sheets, such as Dun's and Bradstreet's, directories—the whole staff of aides-de-camp to commerce, now familiar to all—were then practically unknown. In the public mind, the publication of a book meant that literature, as Literature, had received an accession.

Unquestionably, the framers of the constitution, in vesting Congress with "power to promote the progress of science and the useful arts, by securing for limited times to authors and inventors exclusive right to their respective writings and discoveries," had this kind of authorship in mind; and were the intention of the framers of the constitution to give boundary to the constitutional grant, many writings, to which copyright has since been extended, would have been excluded. But, here as elsewhere, the constitution, under judicial construction, has expanded to new conditions as they arose. Little by little copyright has been extended to the literature of commerce, so that it now includes books that the old guild of authors would have disdained; catalogues, mathematical tables, statistics, designs, guide-books, directories, and other works of similar character. Nothing, it would seem, evincing, in its makeup, that there has been underneath it, in some substantial way, the mind of a creator or originator, is now excluded. A belief that in no other way can the labor of the brain, in these useful departments of life, be adequately protected, is doubtless responsible for this wide departure from what was unquestionably the original purpose of the constitution.

But, obviously, there is a point at which this process of expansion must cease. It would be both inequitable and impracticable to give copyright to every printed article. Much of current publication—in fact the greater portion—is nothing beyond the mere notation of events transpiring, which, if transpiring at all, are accessible by all. It is inconceivable that the copyright grant of the constitution, and the statutes in pursuance thereof, were meant to give a monopoly of narrative to him, who, putting the bare recital of events in print, went through the routine formulæ of the copyright statutes.

It would be difficult to define, comprehensively, what character of writing is copyrightable, and what is not. But, for the purposes of this case, we may fix the confines at the point where authorship proper ends, and mere annals begin. Nor is this line easily drawn. Generally speaking, authorship implies that there has been put into the production something meritorious from the author's own mind;

that the product embodies the thought of the author, as well as the thought of others; and would not have found existence in the form presented, but for the distinctive individuality of mind from which it sprang. A mere annal, on the contrary, is the reduction to copy of an event that others, in a like situation, would have observed; and its statement in the substantial form that people generally would have adopted. A catalogue, or a table of statistics, or business publications generally, may thus belong to either one or the other of these classes. If, in their makeup, there is evinced some peculiar mental endowment—the grasp of mind, say in a table of statistics, that can gather in all that is needful, the discrimination that adjusts their proportions—there may be authorship within the meaning of the copyright grant as interpreted by the courts. But if, on the contrary, such writings are a mere notation of the figures at which stocks or cereals have sold, or of the result of a horse race, or base-ball game, they cannot be said to bear the impress of individuality, and fail, therefore, to rise to the plane of authorship. In authorship, the product has some likeness to the mind underneath it; in a work of mere notation, the mind is guide only to the fingers that make the notation. One is the product of originality; the other the product of opportunity.

Judged by a test like this, the printed matter on the tape in question is in no sense copyrightable. It is, at most, the mere annal of events transpiring. True, the happenings of a race track, or the incidents of a college boat race, may be put in narrative, involving creative imagination; or the doings of a board of trade become the basis of a useful book or article evincing originality. But the printed tape under consideration is no such book or article, and affects no such dignity. It is, in its totality, nothing more or less than the transmission by electricity, over long distances, of what a spectator of the event, occupying a fortunate position to see or hear, would have communicated, by word of mouth, to his less fortunate neighbor. It is an exchange merely, over wider area, of ordinary sight-seeing; and the exchange is in the language of the ordinary sight-seer. Matter of this character is not, within the meaning of the copyright law, the fruit of intellectual labor, and would not, if actually copyrighted, be protected by the courts. *Iron Works v. Clow*, 27 C. C. A. 250, 82 Fed. 316.

Indeed, the printed tape under consideration has no value at all as a book or article. It lasts literally for an hour, and is in the waste basket when the hour has passed. It is not desired by the patron for the intrinsic value of the happening recorded—the happening, as an happening, may have no value. The value of the tape to the patron is almost wholly in the fact that the knowledge thus communicated is earlier, in point of time, than knowledge communicated through other means, or to persons other than those having a like service. In just this quality—to coin a word, the precommunicatedness of the information—is the essence of appellee's service; the quality that wins from the patron his patronage.

Now, in virtue of this quality, and of this quality alone, the printed tape has acquired a commercial value. It is, when thus looked at,

a distinct commercial product, as much so as any other out-put relating to business, and brought about by the joint agency of capital and business ability. In no accurate view can appellee be said to be a publisher or author. Its place, in the classification of the law, is that of a carrier of news; the contents of the tape being an implement only, in the hands of such carrier, in its engagement for quick transmission. This is Service; not Authorship, nor the work of the Publisher.

This, then, brings us to the second inquiry: Is there any remedy that will protect appellee, in this feature of its business, against the piracy of outsiders? Has appellee, in the performance of this service, no appeal to the law?

It will be noted, first, that the business is, as an entirety, a lawful one. It meets a distinctive commercial want, and in some of its branches, at least, adds to the facilities of the business world. Indeed, no argument against its lawfulness has been advanced.

The business involves, also, the use of property. This consideration brings it at once, in a general way, within the protecting care of courts of equity. At first glance the immediate act restrained in the order below—the use of the information by a rival enterprise until after sixty minutes—may not appear as a trespass upon, or injury to, property, other than to the extent that there may be property in the printed matter. But such a view falls short of looking far enough. Property, even as distinguished from property in intellectual production, is not, in its modern sense, confined to that which may be touched by the hand, or seen by the eye. What is called tangible property has come to be, in most great enterprises, but the embodiment, physically, of an underlying life—a life that, in its contribution to success, is immeasurably more effective than the mere physical embodiment. Such, for example, are properties built upon franchises, on grants of government, on good will, or on trade names, and the like. It is needless to say, that to every ingredient of property thus made up—the intangible as well as the tangible, that which is discernible to mind only, as well as that susceptible to physical touch—equity extends appropriate protection. Otherwise courts of equity would be unequal to their supposed great purposes; and every day, as business life grows more complicated, such inadequacy would be increasingly felt.

Nowhere is this recognition by courts of equity of the intangible side of property better exemplified, than in the remedies recently developed against unfair competition in trade. An unregistered trade name or mark is, in essence, nothing more than a symbol, conveying to eye and ear information respecting origin and identity; as if the manufacturer, present in person, and pointing to the article, were to say, "These are mine"; and the injunctive remedy applied is simply a command that this form of speech—this method of saying, These are mine—shall not be intruded upon unfairly by a like speech of another.

Standing apart, the symbol or speech is not property. Disconnected from the business in which it is utilized it cannot be monopolized. But used as a method of making an enterprise succeed, so

that its appropriation by another would be a distinctive injury to the enterprise to which it is attached, the name, or mark, becomes at once the subject-matter of equitable protection. Here, as elsewhere, the eye of equity jurisdiction seeks out results, and though the immediate thing to be acted upon by the injunction is not itself, alone considered, property, it is enough that the act complained of will result, even though somewhat remotely, in injury to property.

Considering that in such case, equity, without question, lays its restraining hands upon the injurious appropriation of words that belong to the common language of mankind—than which nothing could be freer to the uses of men—there ought, it would seem, to be no difficulty, in the case under consideration, to find the power so manifestly needful.

The case under consideration may be summed up as follows: The business of appellee is that of a carrier of information. The gist of its service to the patron is, that, by such carriage, the patron acquires knowledge of the matter communicated earlier than those not thus served. The ticker, with its printed tape, is an implement or means only to this commercial end, which the patron, or the patron's patron, may utilize to the end intended, but may not appropriate to some end not intended, especially if such appropriation result in injury to, or total destruction of, the service. In short, the law being clearly inadequate to that purpose, equity should see to it, that the one who is served, and the one who serves, each gets what the engagement between them calls for; and that neither, to the injury of the other, shall appropriate more.

The immediate business of appellee brought to our attention, in the case under review, may not arouse any great solicitude. It relates to the gathering and distributing of news, not looked upon perhaps, in all quarters, as essential to the public welfare. But the questions raised are of much wider significance. They involve, among others, that modern enterprise—one of the distinctive achievements of our day—which, combining the genius and the accumulations of men, with the forces of electricity, combs the earth's surface, each day, for what the day has brought forth, that whatever befalls the sons of men shall come, almost instantaneously, into the consciousness of mankind. Thus, a gun thunders in a harbor on the other side of the earth; before its reverberations have ceased, the moral sequence of the event has taken root in every civilized quarter of the earth. Famine arises in India to begin its grim march; it has gotten but little under way until a counter army—the unfailing benevolence of human kind—has been mustered from America to Russia. On an isolated island, and without premonition, a mountain claps its black hands upon the population of a city; almost before a ship in the harbor, with tidings of the catastrophe, could have set sail, relief ships from the harbors of Christendom are under way. By such agencies as these the world is made to face itself unceasingly in the glass, and is put to those tests that bring increasing helpfulness and beauty into the heart of our race.

Is service like this to be outlawed? Is the enterprise of the great news agencies, or the independent enterprise of the great newspa-

pers, or of the great telegraph and cable lines, to be denied appeal to the courts, against the inroads of the parasite, for no other reason than that the law, fashioned hitherto to fit the relations of authors and the public, cannot be made to fit the relations of the public and this dissimilar class of servants? Are we to fail our plain duty for mere lack of precedent? We choose, rather, to make precedent—one from which is eliminated, as immaterial, the law grown up around authorship—and we see no better way to start this precedent upon a career, than by affirming the order appealed from.

Affirmed.

Note. BAKER, Circuit Judge, though not sitting in this case, read, in connection with the following case, Illinois Commission Co. v. Cleveland Tel. Co., *infra*, the briefs and record herein, and took part, informally, in the conferences. He authorizes the statement that the reasoning and conclusions arrived at in this case, meet with his concurrence.

ILLINOIS COMMISSION CO. et al. v. CLEVELAND TEL. CO. et al.

(Circuit Court of Appeals, Seventh Circuit. October 28, 1902.)

No. 846.

1. TELEGRAPH COMPANIES—PROPERTY RIGHT IN MARKET QUOTATIONS—UNFAIR COMPETITION.

A telegraph company which by contract with the Board of Trade of Chicago is furnished by such corporation with the continuous market quotations from its exchange, for which the company pays, and which it transmits and distributes to patrons who pay therefor, has a property right in such quotations, which entitles it to protection by injunction restraining others, who are not its patrons, from taking the same from its wires or from the offices of its patrons, and selling or distributing them in competition.

Appeal from the Circuit Court of the United States for the Northern Division of the Northern District of Illinois.

The bill as amended, was by the Cleveland Telegraph Company, a corporation and citizen of the State of West Virginia; and the Western Union Telegraph Company; the Postal Telegraph Cable Company; and the Gold and Stock Telegraph Company, corporations existing under and by virtue of the laws of the State of New York, against appellants, and others, citizens of the State of Illinois. It set forth in substance, the organization of the Board of Trade of the City of Chicago; the general purposes of such Board; its right to make rules, regulations and by-laws, for the government of its affairs; the fact that it has a membership of about eighteen hundred members, and owns an Exchange Building costing upwards of one million dollars; and the manner of its conducting business, the latter as follows: that any person of good character and business integrity can become a member of the said Board of Trade upon application, and paying its regular initiation fee, or acquiring in lieu thereof from a member, a transfer of an existing membership, which is readily purchasable; and that said Board of Trade has provided within such exchange building for the exclusive use of its own members only, an exchange hall, where many of its members meet every business day between the market hours of 9:30 a. m. and 1:15 p. m. (except on Saturday, when the market hours are from 9:30 a. m., until twelve o'clock

noon) to buy and sell for themselves, or as brokers and agents for their customers, for present and future delivery, all kinds of grain and hog products, the volume of said transactions aggregating many millions of bushels of grain and many million pounds of hog products annually, and having become so large that said exchange is now the greatest grain and provision market in the United States; that said purchases are permitted by said Board of Trade to be made, and are made, only during said market hours, and by viva voce bidding; and the information of the prices thus made in said transactions during said market hours upon said Exchange has become a species of property of such large value to the said Board of Trade, that telegraph companies are willing to pay said Board of Trade large sums of money for the privilege of receiving instantaneously said quotations of prices and selling the same to their customers, and many persons throughout the United States who are engaged in the grain and provision business are willing to pay, and for many years have paid said telegraph companies large sums of money therefor; the prices which telegraph companies are able to get from their customers for the instantaneous and continuous quotations of said Board of Trade being as follows:

From Chambers of Commerce outside of the City of Chicago, from \$150.00 to \$300.00 per month.

From individuals outside of the City of Chicago when furnished by telegraph instrument known as the "Morse" instrument, from \$125.00 to \$175.00 per month.

From same persons when furnished by instrument known as "Tape Ticker," from \$6.00 to \$25.00 per week.

From persons in Chicago, \$4.00 per week; and for periodic or non-continuous quotations, as follows:

For quotations every fifteen minutes outside of ticker districts, \$20.00 per week; for like quotations every thirty minutes, \$10.00 per week; for four (4) quotations daily from \$10.00 to \$20.00 per month, depending on the number of articles quoted.

The bill further states the manner of collecting and distributing said quotations, as follows:

Experienced persons are placed during market hours, in each of the different parts of the exchange hall of said Board of Trade where the buying and selling of the different commodities is taking place—these parts being commonly known as "pits"—whose duty it is to at once mark on paper every fluctuation in the market price of the commodity dealt in in such pit, and to immediately transmit said written prices by messengers to a telegraph operator on the floor of said exchange hall, who at once transmits them by a certain electrical instrument called a "transmitter" over telegraph wires connected with said transmitter, and running thence to the various offices and places of business of persons in the city of Chicago, who desire, and are willing to pay for, such quotations, each of such wires being connected in said office with an electrical instrument known as a "ticker" by means of which the quotations which are thus electrically transmitted over such wires to said ticker, are automatically and immediately printed upon an automatically unrolling roll of paper called a "tape," so that persons in said offices can read the same on said tape within less than fifteen seconds after such prices are made in transactions upon such exchange; and such quotations are transmitted to persons outside of the City of Chicago in a similar manner, except that they are required to be and are almost instantaneously retransmitted over telegraph wires by means of a telegraph instrument known as a "Morse" instrument, this retransmission being necessary in order to send such quotations any considerable distance, and by the method herein indicated said continuous quotations can be conveyed to persons in all the cities and towns of the United States within twenty seconds after said prices are made in said transactions of said exchange; and your orator is informed and believes that the yearly expense to said Board of Trade of collecting said quotations as aforesaid, is more than seven thousand dollars (\$7,000.00).

The bill then sets forth the following agreement:

This Agreement, Made this 15th day of April, 1901, between the Board of Trade of the City of Chicago, a corporation, organized under the laws of

the State of Illinois, party of the first part, and The Western Union Telegraph Company, a corporation organized under the laws of the State of New York, party of the second part, and the Postal Telegraph Cable Company, a corporation organized under the laws of the State of New York, party of the third part,

Witnesseth: First. The said Board of Trade agrees to furnish, without discrimination or delay, to the said party of the second part and said party of the third part, complete and continuous quotations of prices made in transactions between members of said Board of Trade in its Exchange Hall. Such quotations shall be received by each of said telegraph companies at its office or offices in the City of Chicago, over a wire or wires to be furnished by the said telegraph company, connecting its office or offices with Morse telegraph wire or wires in the exchange building of the said party of the first part, which shall run to and be connected with the Morse telegraph transmitting instrument upon the floor of said exchange; such transmitting instrument to be the only instrument by which such quotations are to be transmitted from the said exchange hall. Said market quotations shall be collected in the different parts of said exchange hall and be brought to the Morse telegraph operator at said transmitting instrument with as much speed, efficiency and completeness as they were prior to June 22, 1900, collected by the said parties of the second and third parts; and shall be transmitted by said operator with the same diligence, promptness and completeness as the same were prior to June 22, 1900, transmitted by the said parties of the second and third part; the operator, Morse telegraph transmitting instrument and wires leading to the various telegraph companies, parties hereto, to be located at the wheat pit, and within reach of the wheat reporter, said operator to be satisfactory to the telegraph companies. The said party of the first part agrees to employ or cause to be employed, without expense to the party of the second or of the third part, a sufficient number of competent persons for the purpose of collecting and transmitting the said quotations of sales upon said exchange hall, including the necessary force of messengers for carrying said quotations and reports to the transmitting operator, so that the parties of the second and third part shall obtain complete and continuous quotations throughout all sessions of said Board of Trade of the prices at which commodities dealt in on said exchange are bought and sold. The party of the first part agrees that the intention of this clause is to insure that the delivery of its quotations to the parties of the second and third parts hereto shall be simultaneous with and in the same manner as their delivery to any other telegraph company or party to whom they may be furnished for distribution. And said Board of Trade further agrees that said telegraph companies may designate some person of good character and proper behavior to take from the blackboard in said exchange hall, as the same is posted there, all market and statistical information which is posted on said blackboard, and that such person shall have a permit to enter said exchange hall for that purpose.

Second. The said parties of the second and third parts agree that they will not knowingly furnish or sell, directly or indirectly, said continuous quotations to any person, firm or corporation conducting a bucket shop, or other similar place, where such quotations are used as a basis for bets or other illegal contracts based upon the fluctuations of the prices of commodities dealt in on said Board of Trade; nor will they knowingly continue to furnish said continuous quotations to any person, firm or corporation who shall retransmit or furnish the same to any person, firm or corporation conducting such bucket-shop or other place; provided, however, that nothing in this contract shall be construed as imposing upon the said parties of the second and third parts the duty to investigate and determine the character of business conducted by any person, firm or corporation applying for or receiving such continuous quotations, but the procedure to be adopted for the purpose of determining whether any applicant for such continuous quotations, or any person, firm or corporation receiving said quotations, contemplates using them, or is using them, for any of the prohibited purposes aforesaid, shall be as follows:

1. Every applicant for such continuous quotations shall sign in duplicate an application in writing as follows:

"To the Telegraph Company:

We hereby apply to you for the continuous market quotations of the Chicago Board of Trade, and we represent and agree with you, and with the Board of Trade of the City of Chicago, from which you, under contract, have acquired the right to distribute said quotations--

I. That our business is and shall be the business of and that we are not keeping or causing to be kept, and will not keep or cause to be kept any bucket-shop, or any office, store, or other place wherein is conducted or permitted the business of making, or offering to make, contracts, agreements, trades or transactions respecting the purchase or sale or purchase and sale of any grain, provisions or other commodity or property, wherein both parties thereto or the undersigned contemplate or intend that such contracts, agreements, trades or transactions shall be, or may be, closed, adjusted, or settled according or with reference to the public market quotations of prices made on any Board of Trade or Exchange upon which the commodities or securities referred to in said contracts, agreements, trades or transactions are dealt in, and without a bona fide transaction on such Board of Trade or Exchange, or wherein both parties or the undersigned shall contemplate or intend that such contracts, agreements, trades or transactions shall be or may be deemed closed or terminated when the public market quotations of prices made on such Board of Trade or Exchange for the articles or securities named in said contracts, agreements, trades or transactions shall reach a certain figure; and we agree that we will not use or allow anyone else to use such quotations or any of them for any such purpose or in such bucket-shop.

II. We further agree with you, and with the said Board of Trade of the City of Chicago, that said quotations are to be received by us only for our private and individual use, and that said quotations will be used only in our said business; and that we will not sell or communicate or otherwise give said continuous quotations to any news distributing company, or telegraph company, or other person or corporation, nor allow any person or corporation whatsoever to take, directly or indirectly, said continuous quotations from said office, or to make a wire connection with the instruments or wires in said office over which we receive said quotations. But nothing herein shall preclude us from transmitting said quotations to any branch office of ours, nor to any of our correspondents, provided that before transmitting said continuous quotations to any such correspondent we first obtain in duplicate (one of which shall be at once delivered to said Board of Trade) an agreement signed by such correspondent, in which said correspondent shall agree with you, and with said Board of Trade, to abide by and comply with Clauses I, II and III hereof. If the undersigned shall transmit, or permit to be transmitted, said quotations to any person, firm or corporation, who shall not have first signed a correspondent's agreement as above provided, the undersigned hereby agrees that said Board of Trade may sue the person, firm or corporation to whom said quotations are thus transmitted, to prevent the receipt or use of said quotations by said person, firm or corporation without making the undersigned a defendant thereto; provided the undersigned does not, or in case of a partnership, all the members thereof do not, reside within the jurisdiction of the court in which said suit is brought. By 'continuous quotations' in this clause II is meant quotations wherein the price of any commodity shall be quoted oftener than at intervals of ten minutes.

III. We further agree that a strict compliance with the above provisions is and shall be a condition precedent to our right to a continuance of said quotations; and agree if we shall violate either of the above provisions, then you shall have the right at once and without notice, to cut off and cease furnishing said quotations.

We further agree with you that you shall not be pecuniarily liable for the accuracy of the quotations which you may furnish under this application, nor for errors, delays or omissions in the service.

This application shall become a contract binding upon us when accepted by you."

One of such applications so signed shall be by the telegraph company mentioned therein at once transmitted to the party of the first part at Chicago,

which shall thereupon instigate such investigation as it deems proper to determine whether such applicant desires said quotations for said prohibited purposes. Such investigation shall in the case of applications made and delivered to the party of the first part, within thirty days after the date hereof, be completed within sixty days after the date hereof; and when so received after said thirty days, said investigation shall be completed within ten days after such receipt of said application. If said party of the first part shall not within the time above specified notify said telegraph company at its office in Chicago that, for the reasons aforesaid, said application should not be granted, then said application shall be accepted and said telegraph company may thereupon furnish said applicant said quotations; but if within said time said party of the first part shall find upon investigation, and shall notify said telegraph company, that said applicant wishes said quotations for any of said prohibited purposes, said telegraph company shall refuse to furnish said quotations upon said application. If legal proceedings shall thereupon or thereafter be commenced against said telegraph company on account of any delay in receiving said quotations or such refusal to furnish quotations, said proceedings shall be defended by the party of the first part, which shall, and hereby agrees to, pay all counsel and attorney's fees, costs, charges, damages, fines, penalties and expenses which said telegraph company may be put to or may be made subject to on account of such delay or refusal; and for the purpose of securing the said telegraph company against any such loss, expenses or damages occasioned by such delay or refusal or such legal proceedings, the said telegraph companies shall at all times retain from the compensation hereafter provided the amount of such compensation for the period of six months; and to this end, the first payment provided for under this contract shall not be made until seven months after it shall go into effect, and if at any time either of the said telegraph companies shall be obliged to pay any costs, damages or expenses which shall not be refunded to it by said party of the first part on demand, then the said telegraph companies may pay from the said fund so retained the amount so paid by said telegraph company, and may then retain from the subsequently accruing installments a sum sufficient to make good the amount so paid out from said fund for costs, damages or expenses.

2. If said Board of Trade shall at any time ascertain that any person, firm or corporation receiving said continuous quotations from the party of the second or third part, or from persons to whom either party of the second or third part furnishes said quotations, is using said quotations for the purpose of conducting the business of illegal gambling in any of the commodities dealt in on said Board of Trade, or is conducting a bucket-shop as defined by the law of Illinois, or is violating any of the agreements contained in said application or correspondent's agreement, then said Board of Trade may (1) so inform said telegraph company so furnishing said quotations and tender to said telegraph company its bond, with a surety company in good financial standing as surety thereon running to said telegraph company, and in such penal sum as shall be fixed by said telegraph company, conditioned to save said telegraph company harmless from all costs and damages (including attorney's fees) that may be incurred by said telegraph company by acting upon said information and thereon withholding said quotations from such person, firm or corporation. And thereupon said telegraph company shall at once cease to furnish said quotations to such person, firm or corporation, or if a correspondent, then to the person, firm or corporation whose correspondent he is; and in that event said Board of Trade shall, at its own expense, defend any suits brought against said telegraph company, by reason of its said conduct. Or if said Board of Trade shall elect not to give such bond of indemnity then it (2) may at its own expense, commence legal proceedings in a court of competent jurisdiction against such person, firm or corporation and said telegraph company to enforce this contract and determine whether such person, firm or corporation is using said quotations for such illegal purposes, or is using said quotations in conducting a bucket-shop or contrary to the terms of his, its or their agreement aforesaid; and in such suit said telegraph company shall enter its general appearance as defendant,

and if in said suit or in any suit brought by any such person, firm or corporation against either or both of the telegraph companies, parties hereto, it shall be determined by injunctive order or final judgment or decree conclusive upon the parties to said suit, against the right of such person, firm or corporation to have or use said quotations, then said quotation service to such person, firm or corporation shall be discontinued by said party of the second or third part furnishing the same, and said Board of Trade shall indemnify and save said party of the second or third part harmless against any loss, damage or expenses which may result to it by reason of said discontinuance of said service.

Third. It is further agreed by the said Board of Trade that it will cause to be kept quotation records showing the fluctuations throughout the day with the specific time of said fluctuations in the same manner as said quotation records have been heretofore kept, and that said parties of the second and third parts may at all times have access to said quotation records.

Fourth. The said parties of the second and third parts hereby agree to pay said Board of Trade for said quotations and other market news the sum of twenty-five hundred dollars per month, payable on or before the second day of each succeeding month during which they shall receive said quotations, provided that the first payment shall not be required to be made until seven months after the going into effect of this contract, in accordance with the provisions of clause two of this contract. The proportions of said amount which shall be contributed by each telegraph company to be agreed upon between themselves. Thirty days after the termination of this contract the amount of money withheld by the telegraph companies as a security fund aforesaid shall be paid by them to the party of the first part. Provided, that if there are then pending any suits or claims against either of said telegraph companies on account of its refusal to furnish or continue furnishing said quotations, then the parties of the second and third parts shall have the right to retain a sufficient amount of said fund to amply secure them against said suits and claims, and on the final adjudication or settlement of said suits and claims the amount withheld as security therefor shall be paid by the second and third parties to the party of the first part. But if said party of the first part shall give to the parties of the second and third parts a good and sufficient bond ample to protect them against said impending suits and claims, including all costs, damages and expenses, signed by some surety company in good standing and satisfactory to the parties of the second and third parts, then said telegraph companies shall pay the balance of said fund to the first party.

Fifth. The said party of the first part shall designate as parties of the second and third parts some officer of said Board of Trade to whom said telegraph companies, or either of them, shall apply for the correction of any faulty or inefficient service in the gathering, reporting or transmission of said quotations; or for any necessary change in said service and to whom said telegraph companies, or either of them may refer in case of any dispute which may arise as to the correctness of said quotations, and to whom said telegraph companies, or either of them, may apply touching any incidental question arising on account of said quotation service.

Sixth. Said party of the first part agrees to use all reasonable efforts to protect its property right in said quotations against purloiners thereof, and said telegraph companies agree that they will join either with said party of the first part or other telegraph company having the right to distribute said quotations, or both, as plaintiffs in any suit now pending or hereafter commenced, to protect said property right in said quotations from purloiners, provided that said telegraph companies shall be saved harmless by said party of the first part from any expense, costs, attorney's fees and damages incurred in or by reason of any such suit.

Seventh. Each of said parties of the second and third parts agrees that it will, whenever requested by said party of the first part, furnish to it a list of the persons who have discontinued said continuous quotations, to the end that said party of the first part may at all times know the names, locations and street addresses of all persons, firms or corporations then receiving said continuous quotations.

Eighth. It is further agreed that said telegraph companies may furnish said quotations to any other telegraph company with which either of them now have or may hereafter have any operating contract or any other arrangements, provided that every such telegraph company shall first sign a contract or agreement, running to said party of the first part, to abide by and conform to clauses two, six, seven and ten of this agreement.

Ninth. And the said party of the first part hereby agrees that it has not entered into and will not enter into any contract or arrangement with any other person or company who has or may acquire the right to distribute said quotations, in which contract or arrangement the said party of the first part has agreed or shall agree to pass upon applications of persons applying for the quotation service in a shorter period than those above provided for in the second clause of this contract. And it is further agreed that in passing upon applications for said quotation service presented by either of the second or third parties it will act without discrimination as between said second or third parties, or as between either of them, and any other person or corporation sending in applications for its patrons. And whenever the said party of the first part shall have before it at the same time applications from the same person, firm or corporation presented through two or more persons, telegraph, telephone or ticker companies, if it approves any of said applications, it shall approve them all at the same time and shall notify at the same time all of said persons or companies through whom said applications were presented of such approval. This shall apply either when an application is approved affirmatively or by the failure of the said party of the first part to act upon any application.

Whenever either party of the second or third parts shall obtain and deliver to the party of the first part an application for the quotation service from any person, firm or corporation, who at the time of making said application is receiving said quotations with the approval of said first party, then the party of the second or third part may furnish said quotations on said application without waiting for an approval by the party of the first part as hereinbefore provided in other cases.

Tenth. The words "continuous quotations" wherever used in the second and eleventh sections hereof shall be construed to mean every service of quotations wherein the price of any commodity shall be quoted oftener than at intervals of ten minutes. Each of said telegraph companies agrees not to furnish said continuous quotations to any person, firm or corporation, except as provided in sections two and eight hereof, the only intent and purpose hereof being to prevent the misuse of said quotations for said unlawful purposes, or in said unlawful business, and not to discriminate between persons desiring them for other than said prohibited purposes.

Eleventh. This agreement shall be in force for one year from the date hereof and thereafter until the first party shall give to said second party and third party, or said second party and third party shall give to said first party, sixty days written notice of its or their intention to terminate the same.

In witness whereof, the parties hereto have hereunto affixed their signatures and corporate seals, the day and year first above written.

[Seal.]

Attest:

Geo. F. Stone,
Secretary.

Board of Trade of the City of Chicago,
By William S. Warren,
President.

[Seal.]

Attest:

A. R. Brewer,
Secretary.

The Western Union Telegraph Company,
By Thos. F. Clark,
Vice-President.

[Seal.]

Attest:

Chas. P. Bruch,
Ass't. Secretary.

Postal Telegraph-Cable Company,
By W. H. Baker,
Vice-President and Gen'l M'gr.

(Endorsed on back) Filed Aug. 5, 1901. S. W. Burnham, Clerk.

A like agreement was made with the Cleveland Telegraph Company.

The bill then charges appellants with having entered into a conspiracy to steal such quotations, either as the same were transmitted over the Telegraph Companies' wires to their customers, or from the offices of said customers when said quotations are received; and asks for an injunction restraining appellants from obtaining, receiving, selling or distributing such quotations, and for other and further relief. Affidavits were filed, showing that the appellants obtained the quotations after the same were taken from the wires by the patrons of the Telegraph Companies, and written upon their blackboards for the use and information of such people as came into their offices.

The motion for a temporary injunction was heard in the Circuit Court, upon demurrer to the bill, and affidavits; resulting in an order restraining appellants, their respective officers, directors, agents and employees, until the further order of the court, from obtaining, receiving, selling or distributing the market quotations of the Board of Trade of the City of Chicago; and from aiding, abetting or assisting others in the taking or selling, or distributing, of such quotations. From this order the appeal is prosecuted.

Frank F. Reed, for appellants.
Henry S. Robbins, for appellees.

Before JENKINS, GROSSCUP, and BAKER, Circuit Judges.

GROSSCUP, Circuit Judge, after stating the facts as above, delivered the opinion of the Court:

The real questions presented on this appeal we decided in *National Telegraph News Co. v. Western Union Tel. Co.*, 119 Fed. 294. Neither in this case, nor in the one cited, do we decide that the Telegraph Company is not a common carrier of news; that any proposing patron may not have the news upon conforming to the regulations, and the payment of charges, proffered to other patrons; or that the Board of Trade may make an exclusive contract for the transmission of news. None of these questions are material to the judgment to which we have come. The appellants in neither case have brought themselves into a situation where they may claim the service of the Telegraph Company as common carrier, or where they may deny to the Board of Trade its right to make the contract referred to. In this state of the record we are content, on the reasoning of *National Telegraph News Co. v. Western Union Tel. Co.*, to affirm the order below.

Affirmed.

CASSERLEIGH v. WOOD et al.

(Circuit Court of Appeals, Eighth Circuit. November 3, 1902.)

No. 1,728.

1. CONTRACTS—CONSIDERATION.

Whether a contract rests upon a valuable consideration or otherwise must be determined by conditions as they exist when it is made; and, if the promisor supposes that the thing which he seeks to obtain and promises to pay for will be beneficial to him, he cannot avoid his promise on the strength of a subsequent discovery that it was really nonessential, or of no value.

2. FEDERAL COURTS—FOLLOWING STATE DECISIONS—APPLICATION OF STATUTE TO PARTICULAR FACTS.

While the federal court is bound by the construction placed by the highest court of a state upon a local statute, yet, when it becomes necessary to apply the statute, as construed by the local court, to a particular contract, and determine, upon a consideration of all of the provisions of the contract, whether it is violative of the statute as it has been construed, a federal court is entitled to express an independent judgment, the question involved being one of general law, rather than of statutory construction.

3. SPECIFIC PERFORMANCE—CONTRACTS AGAINST PUBLIC POLICY.

Complainant contracted with defendant to furnish evidence deemed essential to establish the defendant's interest as an heir in certain mining property, and to commence litigation, if necessary, to recover such interest. The agreement contemplated that he would produce the witnesses to establish the case, and that, in effect, he should have full direction and control of the litigation through attorneys whom he individually was to select and employ, and that he was "to be at all cost in the matter," in consideration of which the defendant contracted to give the complainant two-thirds of all his interest recovered through law, if legal proceedings were commenced. *Held* that, even if the contract in question was not voidable under the local statute against maintenance, being, as it would seem, a contract entered into for the purpose of gambling in litigation, yet that such an agreement was voidable on grounds of public policy; and that, even if it should be regarded by a court of law as not so voidable, yet that it was so far meretricious, and tainted with illegality, that a court of equity would not enforce it specifically.

Appeal from the Circuit Court of the United States for the District of Colorado.

This is a bill in equity, which was filed by John H. Casserleigh, the appellant, against James O. Wood and the Aspen Mining & Smelting Company and Jerome B. Wheeler, the appellees, to compel the specific performance of a contract made by James O. Wood on July 21, 1887, which is in words and figures following, to wit:

"This agreement, made and entered into this 21st day of July, A. D. 1887, by and between James O. Wood, of Milwaukee, Wisconsin, party of the first part, and J. H. Casserleigh, of Denver, Colorado, party of the second part, witnesseth: That whereas, the said party of the first part, son of the late William J. Wood, deceased, is desirous to recover at law, or by settlement otherwise, all interest he may have or may have had in and to a certain mining claim located near Aspen, Colorado, in Roaring Fork mining district, known as the 'Emma,' and now claimed by Jerome B. Wheeler and others, and as certain evidence necessary to establish the citizenship of the said Wm. J. Wood, who was the locator of said mine, is now in the possession of said party of the second part, procured by him at a large expense of money and use of time, and in consideration of the premises herein stated, I, the party of the first part, do hereby agree to give unto the said party of the second part a two-thirds ($\frac{2}{3}$) of all my interests in and to the amount recovered for me through law, if legal proceedings are commenced, and, if a settlement is had without legal proceedings, then and in that case the said second party is to receive a one-quarter ($\frac{1}{4}$) of all my said interest in and to the amount recovered by such settlement. The said second party is to be at all cost in the matter, and such proceedings as are necessary to a settlement to be commenced forthwith by the said second party or his assignee.

"James O. Wood. [Seal.]

"Signed and acknowledged before me this 21st day of July, A. D. 1887.
 "[Seal.] Geo. A. McGarigle, Notary Public, Wis."

¶ 2. State laws as rules of decision in federal courts, see notes to *Griffin v. Wheel Co.*, 9 C. C. A. 548; *Wilson v. Perrin*, 11 C. C. A. 71; *Hill v. Hite*, 29 C. C. A. 553.

The bill alleged, in substance, that after the execution of the aforesaid contract the complainant, Casserleigh, being unable to obtain a settlement of the claim, retained an attorney by the name of Thomas A. Green to bring an action against Jerome B. Wheeler and the Aspen Mining & Smelting Company, two of the appellees herein, for the recovery of such interest in the Emma mine as James O. Wood, who executed the aforesaid agreement, was entitled to in right of his father, William J. Wood, deceased; that he furnished the said attorney all the necessary information and documentary evidence then in his possession upon which to institute said suit, and arranged with said attorney for compensation for his services, and assigned to him, in payment for his services in prosecuting the litigation, a one-half interest in the aforesaid contract; that the action in question was brought by said Green on April 14, 1888,—only a short time before the right of action to recover said interest would have been barred by the statute of limitations,—and that after various proceedings had in said suit it resulted in a decree on July 30, 1896, under and by virtue of which decree James O. Wood became entitled to one forty-second of whatever interest Jerome B. Wheeler and the Aspen Mining & Smelting Company had in the stock of the Compromise Mining Company growing out of a conveyance of a part of the Emma mine to said Compromise Mining Company, and to a one-tenth interest in a judgment against said Wheeler in the sum of \$195,252.97, with interest thereon at the rate of 8 per cent. per annum from July 16, 1894, and also to a one-tenth interest in a judgment against said Wheeler and the Aspen Mining & Smelting Company in the sum of \$209,328.95, with interest thereon at the rate of 8 per cent. per annum from July 16, 1894. The complainant below further alleged, in substance, that on or about August 1, 1892, he had served on Jerome B. Wheeler individually, and upon him as president of the Aspen Mining & Smelting Company, a notice of his interest in the aforesaid judgment, which he had acquired under and by virtue of the aforesaid contract with James O. Wood; that he had fully performed all the conditions of the aforesaid contract with James O. Wood; that, besides compensating said attorney, Thomas A. Green, who brought said suit, for his services in attending to the litigation so that Wood would not be at any further cost in the matter, he had furnished said attorney the necessary information and documentary evidence then in his possession to enable said attorney to bring and prosecute said suit, and had furnished him with documentary evidence showing that William J. Wood, deceased, had declared his intention to become a citizen of the United States in Allen county, Kan., long prior to his removal to Colorado, and before he had taken part in the location of the Emma mine. He further averred that he had consulted with the attorney whom he had employed to bring said suit from time to time, and had carefully watched all of the proceedings in said cause, and had held himself ready at all times to yield any aid and assistance therein, if he was called upon; that he had theretofore made a demand upon the defendants for a recognition of his interest in the judgment which was recovered in said action under and by virtue of his contract with Wood, but that, notwithstanding such demand, the defendants below had refused to recognize his interest under said existing contract, and that the defendant Wood had failed and refused to keep and perform the terms of said agreement. In view of the premises, the complainant prayed that it might be decreed that James O. Wood held in trust for him the title to one-third of an undivided one forty-second interest in said Emma mine; that he was also entitled to one-third of one forty-second of whatever interest Wheeler and the Aspen Mining & Smelting Company had in the stock of the Compromise Mining Company growing out of a conveyance of a part of the Emma mine to said company, and that it might be decreed that the complainant was entitled to one-third of one-tenth of the two money judgments rendered as aforesaid on July 30, 1896, against Jerome B. Wheeler and against the Aspen Mining & Smelting Company; and that it might be further decreed that the complainant had a lien upon all and everything which was recovered by James O. Wood in the suit which had been brought as aforesaid in his behalf under and by virtue of the provisions of the aforesaid contract. The defendants below demurred to the bill generally upon the ground that it did not contain any matter of equity entitling

the complainant to any relief against the defendants. This demurrer was sustained, and the bill was dismissed. To obtain a reversal of the decree the complainant below has brought the case to this court by appeal.

George W. Taylor (F. J. Mott, on the brief), for appellant.

C. S. Thomas and L. M. Cuthbert (W. H. Bryant, H. H. Lee, Henry T. Rogers, and Daniel B. Ellis, on the brief), for appellees.

Before SANBORN and THAYER, Circuit Judges, and LOCHREN, District Judge.

THAYER, Circuit Judge, after stating the case as above, delivered the opinion of the court.

The general question which arises on this appeal is whether the contract that was entered into by James O. Wood, one of the appellees, under date of July 21, 1887, is a contract of such a nature that it can be specifically enforced by a court of equity; and the determination of this question depends upon the further inquiry whether the contract was founded upon a valuable consideration, as well as upon the inquiry whether it is voidable either on account of its champertous character or because its enforcement would be opposed to public policy. In the lower court the bill was dismissed, as it seems, upon the ground that, as this court had held on July 5, 1892, in the case of *Billings v. Smelting Co.*, 10 U. S. App. 1, 2 C. C. A. 252, 51 Fed. 338, that the evidence which Casserleigh had in his possession, namely, "evidence necessary to establish the citizenship of * * * William J. Wood," was in fact immaterial to the successful prosecution of the suit by the Wood heirs to recover their interest in the Emma mine, the promise of James O. Wood to give a two-thirds part of his interest in the mine for the production and use of that evidence was a promise without consideration, and therefore voidable at the election of the promisor. We are of opinion, however, that if James O. Wood, at the time the contract was entered into, supposed that the evidence to establish the citizenship of his father, which was in Casserleigh's possession, was material and necessary to the successful prosecution of his claim to an interest in the Emma mine, then the contract which he signed was founded upon a valuable consideration, although it was subsequently decided by this court that such testimony was not essential to the establishment of his claim. A promise to pay a given sum for property, or for information which the promisor supposed that he needed, at the time of the making of the promise, surely does not become voidable because of a subsequent discovery that the property or the information was not needed. Whether a contract rests upon a valuable consideration or otherwise must be determined by conditions as they exist when it is made; and, if the promisor supposes that the thing which he seeks to obtain and promises to pay for will be beneficial to him, he cannot avoid his promise on the strength of a subsequent discovery that it was really nonessential, or of no value.

The important question in the case is whether the contract in question is voidable for either of the other reasons mentioned above; that is to say, because it is champertous, or because it is opposed to public policy. That the contract is champertous when tested by the

rules of the common law admits of no controversy. According to the usual definition of champerty, it is that species of "maintenance" which consists of a bargain with a plaintiff or a defendant for a part of the thing recovered in a suit at law or in chancery, be it land or something else, which suit the champertor undertakes to carry on or prosecute at his own expense; and at common law champerty was a public offense. Bouv. Law Dict. 305; Chit. Cont. 676; 4 Bl. Comm. 134, 135; *Duke v. Harper*, 2 Mo. App. 1. Now, by the contract under consideration, it was agreed that Casserleigh should receive two-thirds of whatever might be recovered by Wood by means of legal proceedings on account of his interest in the Emma mine; also that Casserleigh was "to be at all cost in the matter," which plainly means that he should pay all costs if an action was brought, and that he would save Wood harmless therefrom. It is obvious, therefore, that at common law the contract in question was voidable for illegality.

The case, however, cannot be determined solely from the standpoint of the common law, since the contract was a Colorado contract, and in that state the old English statutes relative to maintenance and champerty never were in force, or, if once in force, are so no longer, because the common law on the subject has been superseded by a statute (Mill's Ann. St. Colo. § 1299), which is as follows:

"If any person shall officiously intermeddle in any suit at law or in chancery that in no wise belongs to or concerns such person, by maintaining or assisting either party, with money or otherwise, to prosecute or defend such suit with a view to promote litigation, every such person so offending shall be deemed to have committed the crime of maintenance, and upon conviction thereof shall be fined and punished as in cases of common barratry: provided, that it shall not be deemed maintenance for a man to maintain a suit of his kinsman or servant or poor neighbor out of charity."

The courts of Colorado have held that this statute supplants the common law on the subject of maintenance in that state. *Kutcher v. Love*, 19 Colo. 542, 546, 36 Pac. 152. At common law, maintenance is declared to be an "officious intermeddling in a suit that no way belongs to one, by maintaining or assisting either party with money or otherwise." Chit. Cont. 676; 4 Bl. Comm. 134. The definition of the same offense by the Colorado statute is somewhat different, in that it requires such officious intermeddling by assisting a litigant with money or otherwise to be done "with a view to promote litigation"; and in a recent case which was brought by this appellant against another of the Wood heirs (*Casserleigh v. Wood*, 14 Colo. App. 265, 59 Pac. 1024), where a contract precisely like the one now involved was under consideration, it was held that the gist of the offense, under the Colorado statute, consists of the intent or purpose with which the act of intermeddling is done. It was further held that the statutory offense is committed when a man, with a view of fomenting litigation, encourages another to bring a suit or to make a defense which otherwise he would not have brought or made; and that a contract to assist another in the prosecution of a suit, although the intermeddler engages to bear the costs of the action, and to furnish a part of the evidence which is

deemed essential to maintain it, does not violate the statute unless the contract was entered into in bad faith by the intermeddler, either for the purpose of oppressing others, or with intent to gamble in litigation, or for the purpose of inducing suits which otherwise would not have been commenced. *Casserleigh v. Wood*, 14 Colo. App. 265, 272, 273, 59 Pac. 1024. This decision has very recently been affirmed by the supreme court of Colorado in an opinion not yet reported. *Wood v. Casserleigh*, 71 Pac. 360. This construction of the statute is binding, as a matter of course, upon the federal courts, it being an authoritative interpretation of a local law. But we are of opinion that when it becomes necessary to apply the statute, as thus construed by the local courts, to a particular contract, and determine upon a consideration of all of its provisions whether it is violative of the statute, a federal court is entitled to express an independent judgment. In the case last supposed the question to be determined is one of general law, rather than of statutory construction, and the decision of the federal court thereon ought to be something more than a mere echo of a previous decision of the same question by a court of co-ordinate jurisdiction, although such a decision is entitled to the highest respect, and should be regarded as persuasive authority.

Turning to the contract now under consideration, it is to be observed that the compensation which Casserleigh was to receive for producing the evidence in his possession was wholly contingent on the success of the litigation which he was about to institute. He was not to be paid in any event for the evidence of citizenship which he had secured, or for his other services, but his compensation depended entirely on his bringing the litigation to a successful termination. It furthermore appears from the averments of the bill that the evidence to establish the citizenship of William J. Wood, deceased, and his identity as one of the locators of the Emma mine, did not consist exclusively of documentary evidence, which could not well be falsified. On the contrary, some facts which were deemed of vital importance when the contract was made were to be established by the mouths of witnesses whom Casserleigh had discovered, or claimed to have discovered. Moreover, the agreement contemplated that he would produce these witnesses, and that he should, in effect, have full direction and control of the litigation through the attorneys whom he individually employed, since it is alleged that Wood resided in another state when the contract was signed, and contemplated remaining there during the progress of the suit. Another fact, already mentioned, should also be kept in mind, namely, that Casserleigh made himself responsible for all the costs in the action that might be incurred, and this irrespective of the result of the litigation. In view of these considerations it is difficult to resist the conviction that Casserleigh's purpose in entering into the contract was not to aid a poor and helpless litigant in the prosecution of a claim which he believed to be meritorious, but that his real object was to take advantage of a flaw in another's title for his own benefit; or, in other words, to gamble in litigation. The contract shows that he was to receive by far the greater part

of the money or property which might be recovered if an action was brought and successfully prosecuted, and that he intended to profit more largely by the suit than the person whom he ostensibly befriended. We think, therefore, that it might well be held that the contract in question is voidable under the Colorado statute of maintenance, within the construction which has been placed on the statute by the local courts, because it appears from the provisions of the contract and the allegations of the bill that Casserleigh, by promising to produce evidence which was deemed absolutely essential to a recovery, and by engaging to bear the costs of litigation, induced the bringing of a suit concerning a subject-matter in which he had no interest whatever; and that he did so for his own benefit, hoping to derive a large profit from money invested in maintaining a law suit. Most any one would permit an action to be brought in his name under the favorable conditions on which the appellant proposed to bring a suit against the owners of the Emma mine, and it may well be that the action would not have been brought but for his active efforts in that behalf and promise of assistance.

But even if the contract in question is not voidable under the aforesaid statute and for the reasons heretofore stated, the question nevertheless arises whether such a contract is not so far opposed to public policy that the courts—particularly a court of chancery—should decline to enforce it. In the case of *Peck v. Heurich*, 167 U. S. 624, 630, 17 Sup. Ct. 927, 42 L. Ed. 302, Mr. Justice Gray, speaking for the court, said, in substance, that, even where the English statutes of champerty have become obsolete, or have never been adopted, an agreement by an attorney to prosecute a suit at his own expense to recover an interest in land in which he has no personal interest, present or contingent, in consideration of receiving a part of what is recovered, is regarded as voidable on grounds of public policy according to the rules of the common law as generally recognized in those states where they have not been modified by statute. Many other courts have also held that, while a lawyer may agree to take a contingent fee, to be paid out of what is recovered in an action, yet it is contrary to a sound public policy to uphold contracts where a lawyer, in addition to agreeing to take a contingent fee, payable in kind out of what is recovered, also stipulates to bear all of the costs of the action, thereby inducing others to bring doubtful and speculative suits, without risk to themselves, which otherwise might not have been brought. *Railway Co. v. Brady*, 39 Neb. 27, 50, 57 N. W. 767; *Boardman v. Thompson*, 25 Iowa, 487, 499; *Jewel v. Neidy*, 61 Iowa, 299, 300, 16 N. W. 141; *Lafferty v. Jelley*, 22 Ind. 471; *Aultman v. Waddle*, 40 Kan. 195, 202, 19 Pac. 730; *Dockery v. McLellan*, 93 Wis. 381, 67 N. W. 733. See, also, *Belding v. Smythe*, 138 Mass. 530, 532; *Duke v. Harper*, 66 Mo. 51, 37 Am. Rep. 314; *Brown v. Bigne*, 21 Or. 260, 28 Pac. 11, 14 L. R. A. 745, 28 Am. St. Rep. 752. If contracts of that kind, when made, either by a lawyer or a layman, are upheld and enforced, the tendency would undoubtedly be to occasion much unnecessary, vexatious, and oppressive litigation, as persons can generally be found who are ready and willing to take advantage of any defect or flaw, no matter how slight, in another's

title, and to prosecute an action to upset it, at their own expense, especially if the property involved is of great value, and the reward, in case of success, promises to be large. Men can be found who are prone to speculate in litigation as in other subjects. While such contracts may at times result in the enforcement of rights that would otherwise be lost, yet we are persuaded that, as a general rule, they tend to disturb the peace of society and occasion suits that otherwise would not have been brought, and which ought not to have been brought. We are of opinion, therefore, that, even if it be conceded that there is no statute in the state of Colorado expressly interdicting the practice of that species of maintenance which is termed "champerty," yet, in virtue of the general rules of the common law, which are in force there as they are everywhere, the contract now under consideration is voidable, and the enforcement thereof ought to be denied on the ground of public policy. We are also of opinion that, even if an action at law could be maintained for a breach of the contract, yet it is so far meretricious and tainted with illegality that a court of equity ought not to enforce it specifically.

The decree appealed from being for the right party, it is accordingly affirmed.

CITY OF OTTUMWA, IOWA, v. CITY WATER SUPPLY CO.

(Circuit Court of Appeals, Eighth Circuit. November 26, 1902.)

Nos. 1,658, 1,712.

1. JURISDICTION OF FEDERAL COURTS—AMOUNT IN DISPUTE—SUIT BY TAXPAYER FOR INJUNCTION.

In a suit by a taxpayer to enjoin a city from issuing bonds claimed to be in excess of the constitutional limit of its indebtedness, the power of the city to issue such bonds is the matter in dispute for the purpose of determining whether the amount or value in controversy is sufficient to give a federal court jurisdiction, and not the tax to which complainant would be subjected.

2. SAME—FOLLOWING STATE DECISION—APPLICATION OF LOCAL LAWS.

While the federal courts are bound by the construction placed by the highest court of a state on a state statute or constitutional provision, when it becomes necessary to apply the statute or provision, as thus construed by the local courts, to a particular contract, and to determine from a consideration of all its provisions whether it is a violation of the law, a federal court is entitled to express an independent judgment.

3. MUNICIPAL CORPORATIONS—LIMITATION ON POWER TO CREATE INDEBTEDNESS—IOWA CONSTITUTION.

The constitution of Iowa provides (article 11, § 3) that "no county or other political or municipal corporation shall be allowed to become indebted in any manner or for any purpose to an amount in the aggregate

¶ 1. Jurisdiction of circuit courts as determined by amount in controversy, see notes to *Auer v. Lombard*, 19 C. C. A. 75; *Shoe Co. v. Roper*, 36 C. C. A. 459.

¶ 2. State laws as rules of decision in federal courts, see notes to *Railway Co. v. Ziegler*, 9 C. C. A. 548; *Wilson v. Perrin*, 11 C. C. A. 71; *Hill v. Hite*, 29 C. C. A. 553.

¶ 3. Constitutional and statutory limitations of municipal indebtedness, see note to *City of Helena v. Mills*, 36 C. C. A. 6.

exceeding five per centum on the value of the taxable property within such county or corporation, to be ascertained by the last state and county tax lists previous to the incurring of such indebtedness." The city of Ottumwa, which was at the time indebted to an amount beyond such limit, passed an ordinance authorizing the issuance of nearly \$400,000 in negotiable bonds to be sold by the city, and the proceeds used in the construction of a waterworks plant to be owned by the city, and such action was subsequently approved by a vote of the electors. The bonds were to be payable at stated times, to bear interest payable semiannually, and to be secured by a mortgage on the water plant. The ordinance also levied a sinking fund tax of two mills for the current year and every year thereafter until the cost of the plant should be fully paid, and pledged the proceeds of such tax to the payment of the principal and interest of the bonds. It further provided that there should be levied every year after the construction of the waterworks a water tax of 5 mills, or so much thereof as might be necessary, together with the net proceeds of the water rents, to pay the cost of maintenance, etc., "and to pay any of the purchase price or cost of constructing said works, or bonds or mortgages issued therefor, or interest thereon, which shall not be paid from the proceeds of the two mill tax provided for in section 2 thereof." Any surplus arising from such water tax or water rentals was pledged to the payment of the bonds, and it was provided that no part of the same, principal or interest, should be paid out of any fund, levy, or tax other than those so provided. *Held*, that such bonds would create an indebtedness of the city within the meaning of the constitutional provision, and that the city was without power to issue the same; that the plain purpose of such provision was to restrict the power of the legislature to authorize, and of municipalities to create, obligations "in any manner or for any purpose" in excess of the limit imposed, which must be paid by taxation, and that it could not be evaded by the previous levy of a continuing tax, and by providing that the obligation should be paid only from its proceeds, even if such limitation was absolute, as was not the case with the bonds in question, under which the holders would have the additional right to compel the levy of the water tax to the full limit from year to year for their benefit, if necessary to meet maturing payments, so long as any of the bonds were unpaid.

Appeals from the Circuit Court of the United States for the Southern District of Iowa.

By Ordinance 566, passed by the city council of the city of Ottumwa August 21, 1899, it was provided and ordained that the city of Ottumwa accepts and elects to exercise the powers granted it by chapter 5 of the Code of Iowa of 1897, as amended, and to acquire by purchase or erection a system of waterworks for supplying the city and its inhabitants with water. To create a sinking fund for such purchase or erection, there was levied by said ordinance for the year 1899, and every year thereafter until the purchase or contract price for the waterworks should be fully paid, a tax of two mills on the dollar on all property within the corporate limits of the city, except lots greater than 10 acres, used for horticultural or agricultural purposes; the proceeds of such tax levy to be used exclusively to pay the purchase price or cost of such waterworks and any bonds, mortgages, or other obligations issued therefor, with interest; also that there should be levied every year on all taxable property within the limits of benefit and protection of the waterworks a water tax of five mills on the dollar, or so much as should be necessary, together with the net proceeds of water rents collected from consumers, to pay the cost of maintenance, operation, repairs, extensions, and improvements, and any of the purchase price or cost of construction, or bonds or mortgages issued therefor, or interest thereon, not paid from the proceeds of said two-mill tax. The ordinance, after some provisions for an effort to purchase the waterworks of the appellee, which need not be further noticed, provided that, if such effort failed, the city council should cause plans and specifications for waterworks to be prepared, advertise for bids, and contract

with the lowest bidder; the contract to be subject to the approval of the electors of said city at a special election to be called. By an amendment to said ordinance, passed February 4, 1901, it was provided that, to create a special fund to pay the cost of erecting the contemplated waterworks in case the electors of the city should approve the contract for such erection, a sufficient number of bonds, enough, with the sinking fund on hand, to pay the contract price for the waterworks and connected expenses, should be issued in denominations not less than \$100 nor more than \$1,000, bearing semiannual interest not more than 4½ per cent., and payable \$5,000 two years from their date and \$5,000 at the end of each year thereafter for 22 years, and then not less than \$10,000 per year not exceeding 50 years from their date, such payment to be secured by a mortgage on the system of waterworks, and that to such payment should be pledged the entire proceeds of the two-mill sinking fund tax and so much of the water rates and rentals from consumers and of said water tax as might not be needed for maintenance, operation, repairs, extensions, and improvements; that said bonds should be sold for not less than par, and the money received therefor be held by said city as a special and trust fund to pay for the construction and completion of the waterworks; that the contract for the erection of the works should provide for payment out of said funds only; and that the city should assume no other obligation than that of negotiating and selling said bonds and holding said fund for the purpose of paying for said plant, and that the fund should be devoted to no other purpose; the bonds to be sold before the erection was begun, or during the progress of the work to pay monthly estimates, or turned over to the contractor to pay as the work progressed, should the city so contract. On March 30, 1901, in accordance with a bid accepted by said city council, said city, through its proper officers, entered into a written contract with the Fruin-Bambrick Construction Company for the construction by that company of such waterworks in accordance with plans and specifications mentioned for the sum of \$398,991; the work to be begun within 60 days after the ratification and approval of the contract by the electors of said city at a special election to be called, or as soon thereafter as the city should succeed in negotiating and selling its bonds for the purpose of creating a trust fund; the work to be completed by June 25, 1902. Thereupon the appellee, a corporation of the state of Maine, filed its bill of complaint in the circuit court of the United States for the Southern district of Iowa, alleging that complainant owned a large amount of real estate and personal property in said city on which was expended more than \$500,000, and which was mainly devoted to supplying said city and its citizens with water, under franchises derived from said city, and is a large taxpayer of said city, and that its annual tax charge and payment equals and exceeds \$2,000. That the Iowa constitution provides that no municipal corporation shall be allowed to become indebted in any manner or for any purpose to an amount in the aggregate exceeding 5 per centum on the value of the taxable property within such corporation, as ascertained by the last state and county tax lists previous to the incurring of such indebtedness; and that the valuation of the taxable property within said city as ascertained by the last state and county tax list made for the year 1900 was \$2,394,890. That the limit of indebtedness it could incur lawfully was \$119,744.51, and that on the 30th and 31st days of March, 1901, it was already indebted more than \$123,000. That a special election to ratify and approve said contract for the erection of waterworks had been called; and that such contract, if entered into and carried out, would increase the then existing indebtedness of said city \$400,000. That the matter in dispute in the suit exceeded \$2,000, exclusive of interest. And complainant prayed for decree enjoining the holding of the special election and the issuing of any bonds in accordance with said ordinances and contract, and for other relief, including a similar injunction pendente lite. The defendant city took issue by demurrer and plea to the allegations of the bill that the matter in dispute in the suit exceeds \$2,000, exclusive of interest. Its answer, also filed, in effect admitted all the other facts above recited, and the allegations of the bill above stated, as to the existing indebtedness of the city and the value of the taxable property within the city as shown by the last state and county tax lists. Upon full hearing July 31, 1901, the

court ordered the temporary injunction as prayed, except that the proposed special election was not enjoined, and from this order the defendant appealed to this court. Afterwards, on November 25, 1901, upon leave of the court duly obtained, the complainant filed its supplemental bill in said cause, reciting the original bill and proceedings thereunder, and that at a special election held in said city September 7, 1901, the canvass of the votes showed that said contract between said city and the Fruin-Bambrick Construction Company was approved by the electors, and that said city threatened and was about to carry out said contract and incur indebtedness in excess of the constitutional limit; and upon said supplemental bill, and the answer of the city thereto, and further showing, the court, on December 21, 1901, ordered a further temporary injunction, enjoining and restraining said city and its officers from issuing or causing to be issued, executed, or negotiated any bonds or other obligations of said city pursuant to said ordinances, and from doing any act under said contract with said Fruin-Bambrick Construction Company. From this order the second appeal to this court is taken. Pursuant to stipulation, the two appeals were consolidated and heard together in this court.

W. H. C. Jaques (Geo. F. Heindel and J. R. Jaques, on the brief), for appellant.

Wm. McNett and Wm. A. Underwood, for appellee.

Before SANBORN and THAYER, Circuit Judges, and LOCHREN, District Judge.

LOCHREN, District Judge, after stating the case as above, delivered the opinion of the court.

1. The amount in dispute in this suit, if only measured by the injury to the complainant from the increased taxation of its property in the city of Ottumwa necessary to provide for the payment of bonds proposed to be issued for the construction of the new waterworks, was more than sufficient to sustain the jurisdiction of the circuit court. Whether we consider the proportion of the \$398,991—the cost of the proposed waterworks—which would rest on the complainant's property as part of the taxable property of the city, or the two-mill tax thereon during the period of 50 years provided for, the burden or incumbrance which would be made to rest on the property of complainant would considerably exceed the sum of \$2,000.

But the city of Ottumwa was about to enter into the proposed contract for the erection of waterworks, and issue and negotiate bonds of the city as proposed to the amount of \$398,900 to procure money to pay for the same. Complainant contends that the city, being already indebted beyond the constitutional limit, has no right or power to enter into such contract or issue such bonds. Whether it has or has not such power to issue and negotiate that large amount of bonds is certainly the matter in dispute in this suit, brought to restrain and prohibit the city from taking such action. *Johnston v. City of Pittsburg* (C. C.) 106 Fed. 753; *Rainey v. Herbert*, 5 C. C. A. 183, 55 Fed. 443; *Market Co. v. Hoffman*, 101 U. S. 112, 25 L. Ed. 782; *Railroad Co. v. Ward*, 2 Black, 485, 17 L. Ed. 311; *Stinson v. Dousman*, 20 How. 461, 15 L. Ed. 966; *Scott v. Donald*, 165 U. S. 107, 114, 17 Sup. Ct. 262, 41 L. Ed. 648.

2. Section 3 of article 11 of the constitution of Iowa is as follows:

"No county or other political or municipal corporation shall be allowed to become indebted in any manner, or for any purpose to an amount in the

aggregate exceeding five per centum on the value of the taxable property within such county or corporation, to be ascertained by the last state and county tax lists previous to the incurring of such indebtedness."

The language of this section is plain and simple, and its meaning is unmistakable. The incurring of indebtedness beyond the amount limited is absolutely and unqualifiedly prohibited, no matter what the pretext or circumstances, or the form which the indebtedness is made to assume. It curbs equally the power of the legislature, the officials, and the people themselves; and was designed to protect the taxpayers from the folly and improvidence of either, or of all combined. When the ordinances referred to in the foregoing statement were passed, and the contract for the erection of the waterworks entered into subject to the approval of the voters, which approval has since been had, it is admitted that the city of Ottumwa was, and still remains, indebted beyond its constitutional limit, and that it could not and cannot incur any further indebtedness "in any manner or for any purpose." Under these ordinances and that approved contract, the city now proposes to issue and sell at par its bonds to the amount of \$398,900, bearing interest at $4\frac{1}{2}$ per cent., payable semi-annually, the principal payable at stated times, as above mentioned; and with the money obtained by the city from the sale of such bonds to cause to be constructed under said contract the projected system of waterworks, to be owned by the city when constructed. The scheme thus stated, in its principal features, without considering the details which are claimed to have the effect of wholly changing its character, plainly involves the incurring of indebtedness by the city to the amount of the bonds. The bonds are obligations of the city to pay the amounts thereof to the holders as the bonds and coupons shall mature. The city is to sell the bonds at par, and use the proceeds for the construction of its own waterworks plant, constructed for its municipal uses and purposes. The city, therefore, by the transaction, will borrow the money from the purchasers of the bonds, obligate itself to repay it according to the terms of the bonds, and invest the money thus borrowed in property to be owned by it and used for a municipal purpose.

But it is contended by the appellant that no indebtedness on the part of the city will be incurred by the issuing and negotiation of such bonds and construction of such waterworks, because in the ordinances referred to for the purpose of creating a sinking fund to be used in the erection of a system of waterworks there is levied for the year 1899 and each year thereafter till the cost of the waterworks is fully paid a tax of two mills on the dollar upon all property within the limits of the city, except lots greater than 10 acres, used for horticultural or agricultural purposes. The proceeds of such tax are to be used exclusively to pay the cost of construction of such waterworks and any bonds, mortgages, or other obligations issued to pay such cost and the interest thereon. And, further, that there shall be levied each year on all taxable property lying within the limits of benefit and protection of the waterworks, after its construction, a water tax of five mills on the dollar, or so much thereof as may be necessary, together with the net proceeds of water rents collected, to pay the

cost of maintenance, repair, and operation of the waterworks and extensions and improvements, "and to pay any of the purchase price or cost of constructing said works, or of any bonds or mortgages issued therefor, or interest thereon, which shall not be paid from the proceeds of the two-mill tax." It was also provided that the payment of the bonds and the interest thereon shall be secured by a mortgage on the system of waterworks, and to the payment thereof shall be pledged the entire proceeds of the two-mill sinking fund, and so much of the proceeds of the water rates and rentals and of said five-mill water tax as may not be needed for the maintenance, repairs, operation, extension, and improvement of the waterworks. Said ordinances further provide that no part of the cost of said waterworks, or any of the bonds issued therefor, shall ever be paid out of the general funds of said city, or out of any fund or the proceeds of any tax other than the property and funds specifically named, and that such provision and limitation shall be recited in the bonds; and hence it is argued that the transaction will not create any indebtedness on the part of the city, but that the money borrowed by the city from the purchasers of the bonds will be only an anticipation by the city, for its present use, of specific revenues which it has provided for, to accrue in the future. This contention of the appellant is based upon a palpable jugglery of phrases, and cannot be maintained. If it can, the constitutional provision above quoted, which prohibits any municipality from becoming indebted beyond the specified limit "in any manner or for any purpose" is delusive, and of no avail to protect taxpayers. Here the city of Ottumwa is admittedly indebted beyond the constitutional limit. It is conceded that legislative sanction is powerless to authorize it to increase its indebtedness. It proposes to issue and sell at par its bonds to the amount of nearly \$400,000 to raise money to construct waterworks to be owned by the city. The bonds are to be formal obligations of the city to pay the interest and principal, as the same shall mature, from moneys to be raised and collected by taxes levied on the taxable property of the city. The mixing of water rent surplus with the "sinking fund" means nothing, as, in addition to the water rents, an annual tax of five mills is agreed to be levied yearly to provide the annual current expenses of operating the waterworks. The city has no revenue, nor means of raising money, except by levy of taxes. It is admitted that if the scheme contemplated the payment of the bonds only from a two-mill tax, which was agreed to be levied year by year for their payment, an indebtedness of the city would be created; but it is contended that by making one levy now of an annual two-mill tax, to be collected of the taxpayers year by year for 50 years, or till the bonds are paid, and from which fund only they are to be paid, no indebtedness is created, and that the borrowing of the money for which the bonds are negotiated is but a simple method of anticipating for present use the future revenue, which will come from the tax so levied covering the future years. We think the taxpayer in future years will regard this scheme as a subterfuge to deprive him of the protection of the constitution, and that the thought will force itself upon him that a city creates an indebtedness when it borrows money to be paid, with

interest, from taxes in the future, whether such taxes are formally levied at one time, covering that future, or yearly, to meet the payments when about to mature.

The creation of an indebtedness by an individual is often effected by borrowing money for his present uses, and always in anticipation of his future revenues and resources, whether he has a reliable source of revenue or it is only uncertain and hoped for. If he has a reliable fixed income in property rentals, for example, and agrees with the lender that he will devote and set apart and apply in satisfaction of the loan all the rents—already fixed in amount—which he will receive and collect from a specified building or estate, yearly, as he shall collect the same, and the lender agrees to be content with that arrangement, and that he will not seek to otherwise recover the sum loaned, is it not clear that the borrower is indebted to the lender until the loan is satisfied by payment? The rents agreed to be applied are owing by the tenants to the borrower. When paid by the tenants, the money belongs to their landlord, the borrower, and never belongs to the lender until paid over to him by the borrower; and then, and not before, it is applied to the satisfaction of the loan. If the borrower should, after receiving such rents, fail to pay the same to the lender, the latter would become released from his agreement to wait for the rents, and could proceed against his debtor generally. This supposed case is precisely analogous to the scheme of the city of Ottumwa which we are considering. If the proposed bonds are issued and negotiated, the city will borrow from each bond purchaser the amount he pays for the bonds so purchased. The bonds constitute and embody the agreement and obligation of the city to pay the sums so borrowed and interest, but only from the collections of a particular tax which it has levied once for all, covering the future, year by year, and which it obligates itself to collect, year by year, and apply to the payment and satisfaction of the interest and principal of the bonds. The bondholders have no interest in or dominion over this tax so levied, and cannot collect it, or in any way coerce the taxpayers. The city alone can collect such tax, with its other taxes. When paid by the taxpayers, the money goes into the treasury of the city, and belongs to the city, like all other moneys raised by general taxation levied for specific purposes, as for the construction of streets, bridges, sewers, or support of schools. The money so collected from the taxpayers by the city never belongs to the bondholders till it is actually paid over to them by the city. If the city should fail to pay it over, its contract with the bondholders, expressed in the bonds, would be broken, and the bondholders released from the limitation requiring them to await the accumulation of moneys in a particular fund to be so raised by taxes for the payment of the city's indebtedness on the bonds. The proposed mortgage of the waterworks to secure the payment of the bonds emphasizes the fact that the city is indebted in the amount of the bonds by such pledge of the city's property for their payment. A mortgage which is to be discharged by the payment of money secures an indebtedness, and cannot exist without the existence of a debt. Even if the creditor's remedy is limited by the contract to the property of the debtor which is cov-

ered by the mortgage, the relation of the debtor and creditor exists, and the debtor pays the debt when his mortgaged property is converted into money to discharge it, just as certainly as if, in the absence of any mortgage, his same property were sold under execution for the same purpose.

Appellant's contention amounts to this: That, notwithstanding the constitutional limitation referred to, and that the city, being already indebted beyond that limit, has no power, even with legislative sanction, to incur any new indebtedness to the amount of a single dollar, it may nevertheless borrow money to the extent of \$400,000, issuing its negotiable bonds therefor, with interest, contracting to pay the same at specified dates, and that this will not create any indebtedness, if it shall at the same time levy taxes to be collected annually from the taxable property of the city for a long term of years, or indefinitely till the sum borrowed is paid therefrom, and provide that the bonds shall only be paid from the taxes so specially levied. If this may be done to build waterworks, the city may go on, and in the same way borrow and issue its bonds for an equal amount to build public buildings, and for another equal amount to construct a system of sewers, and for another equal amount to construct modern schoolhouses, and an unlimited amount as bonus to some railroad, taking care in each case to levy once for all a sufficient annual tax to meet the maturing bonds; and, though the property of the taxpayers may be thus practically confiscated, by being loaded down with taxes beyond any income which the property can produce, and for periods beyond any expectation of life which the taxpayers can indulge in, still those taxpayers, while groaning under such special levies, fixed upon them and extending hopelessly into the future, will have the happiness and satisfaction of knowing that they live in a city which has no municipal indebtedness large enough to cause uneasiness.

The fact that these proposed bonds are to bear interest at $4\frac{1}{2}$ per cent. cannot be overlooked. Why should the city pay interest—that constant, distinguishing, most irksome, and disagreeable feature of indebtedness—upon money which it does not owe; money which belonged to it before it was received; being only its own fixed revenues, gotten hold of for present use, a little in advance, by “anticipation,” and in no wise by incurring indebtedness? Up to the time when the circuit court granted in this suit the injunctions which are the subjects of these appeals, there was no decision of the supreme court of Iowa adjudging that a city could issue and negotiate bonds like the proposed issue under consideration, without creating any indebtedness, by merely making such bonds payable only out of the proceeds of a special tax at the same time levied on the taxable property of the city, and payable yearly, during a long term, by the taxpayers of the whole city, like all other taxes. The cases in that state bearing on the subject were all reviewed in *Windsor v. City of Des Moines*, 110 Iowa, 175, 81 N. W. 476, 80 Am. St. Rep. 280, and it must be admitted that there are loose dicta of judges in some of them which tend in that direction. In other states having like constitutional provisions such attempted evasion of the constitution has not generally

been sustained. *Prince v. City of Quincy* (Ill.) 21 N. E. 768; *City of Joliet v. Alexander* (Ill.) 62 N. E. 861; *Earles v. Wells* (Wis.) 68 N. W. 964, 59 Am. St. Rep. 886; *Brown v. City of Corry* (Pa.) 34 Atl. 854. But the supreme court of Iowa, in *Swanson v. City of Ottumwa*, 91 N. W. 1048, by its decision filed October 25, 1902, since the hearing of this cause in this court, sustains in full the contention of the appellant in this cause; holding that the proposed issue of bonds by said city to the amount of \$400,000 will not, for the reasons urged by appellant, and fully stated above, create any indebtedness against the city of Ottumwa. This decision does not rest upon any peculiar construction of the constitution or statutes of Iowa. It holds in terms, as we do, that the provision of the Iowa constitution absolutely prohibits municipalities from contracting indebtedness in any manner or for any purpose in excess of the 5 per cent. limit. And we agree with its holding that the Iowa statutes authorizing cities to levy a continuing two-mill sinking fund tax for the purchase or erection of waterworks, and to pledge the proceeds of such tax and the net revenues to be derived from the waterworks, and the surplus of the annual tax not exceeding 5 mills, to meet operating expenses, to the payment of the purchase price or cost of construction of such works, and satisfaction of any bonds or mortgage for the security of such payment, and by contract restricting payments to moneys produced from such revenues, are constitutional; as, consistently with the constitution, they will apply to municipalities which are not indebted, or where the indebtedness to be incurred for such waterworks will not increase the total indebtedness of the municipality beyond the 5 per cent. limit. There is nothing on the face of these statutory provisions which can stamp them as a legislative evasion of the constitutional limitation in respect to municipal indebtedness. And it must be held that such statutory powers can only be exercised in cases where their exercise will not conflict with any constitutional restriction. The Iowa supreme court, after referring to these statutes, quotes the constitutional limitation above set forth, and very justly adds:

"The statute we have under consideration does not in terms or by necessary implication provide for the creation of any indebtedness by a city in excess of the limit here named, and therefore cannot be said to be void for unconstitutionality."

To this statement we fully agree, and we concur entirely in the statement by that court of what is the vital and only question in the case, as follows:

"But the finding of the constitutionality of the statute does not necessarily imply the validity of all the contracts made thereunder; for, if the obligation assumed by the city in such an enterprise is a 'debt' within the meaning of the constitution, it is valid only when such debt is within the 5 per cent. limit. Here we have indicated the vital question in the case before us. Does the contract create an indebtedness against the city? If answered in the affirmative, the judgment of the trial court is right, and must be affirmed; but, if answered in the negative, the judgment should be reversed, and the injunction dismissed."

This question,—whether the proposed contract of the city for the construction of waterworks to be owned by it, and the issue and

sale of its bonds to borrow nearly \$400,000 to pay for such construction, will create an indebtedness against the city,—if not answered by its bare statement, must be solved by reference to the law applicable to contracts in general, and to negotiable bonds in particular. And while we agree with the Iowa supreme court in its construction of its constitution and statutes, we are not bound by the opinion of that court that the proposed contract and issue of bonds will not violate the provisions of the constitution thus construed. What is said by Judge Thayer in the recent case of *Casserleigh v. Wood*, 119 Fed. 308, is pertinent here:

"But we are of opinion that, when it becomes necessary to apply the statute, as thus construed by the local courts, to a particular contract, and determine, upon a consideration of all its provisions, whether it is a violation of the statute, a federal court is entitled to express an independent judgment. In the case last supposed the question to be determined is one of general law, rather than of statutory construction, and the decision of the federal court thereon ought to be something more than a mere echo of a previous decision of the same question by a court of co-ordinate jurisdiction, although such a decision is entitled to the highest respect, and should be regarded as persuasive authority."

We have examined carefully the opinion in *Swanson v. City of Ottumwa* and the cases which are supposed to give support to its conclusions. It will not be profitable to review in detail the reasoning employed to reach the result arrived at. To our minds it is not persuasive, and we decline to be guided by it. Its citations exhibit the unceasing attempts in that state and some others to nullify and evade wholesome constitutional limitations upon the power of municipalities to create indebtedness, and thus place intolerable burdens on the taxpayers; and its reasoning but adopts the ingenious but obviously untenable arguments by which such attempts have ever been supported. In the case of *Swanson v. City of Ottumwa* the supreme court of Iowa holds, in accord with the contention of the appellant in this case, that the city of Ottumwa, though already indebted beyond the constitutional limit, may now borrow \$400,000 to construct waterworks by the issue and sale of its negotiable, interest-bearing bonds to that amount, to be paid by taxation on the taxable property of the city collectible year by year for 50 years, and that the city will not thereby create any indebtedness if, at or before the issuing of such bonds, it levies, once for all, this continuous yearly tax, and bargains with the bondholders that the bonds are to be paid only from the fund which shall be produced or accumulated from the proceeds of this continuous yearly tax, with a vague possibility of re-enforcement from a surplus of water rentals over and above the cost of operating, maintaining, and extending the waterworks. But the whole reasoning of the Iowa supreme court drives it to this admission: That if the bondholders are not confined to such provided fund, and have the right to go beyond that, and under any circumstances require that the city shall in any future year levy any tax to make payment on the bonds, then an indebtedness is created by the issue and sale of the bonds, and the constitution violated. And that court overlooks or ignores the fact that future taxation for the payment of the bonds under specified circumstances,

and if the provided fund shall happen to be in any year insufficient to pay the maturing principal and interest, is distinctly provided for by the ordinances and proposed contract under consideration, which provides that there shall be levied every year after the construction of the waterworks a water tax of five mills on the dollar, "or so much thereof as may be necessary, together with the net proceeds of the water rents, to pay the cost of maintenance, repairs," etc., "and to pay any of the purchase price or cost of constructing said works, or bonds or mortgages issued therefor, or interest thereon, which shall not be paid from the proceeds of the two-mill tax provided for in section two hereof." This quotation is from section 3 of ordinance No. 566, and will be found quoted at large near the beginning of the opinion of Judge Weaver in the Iowa case. That ordinance is the one which levies the continuing two-mill tax, and contains the whole contract between the city and the bondholders in respect to the issue and payment of the proposed bonds. Is it not perfectly clear, under the clause of section 3 above quoted, that, if in any year a water tax of only one mill shall be needed, together with the net proceeds of the water rents, to pay the cost of maintenance, repairs, etc., and at the same time there is matured and due principal and interest of the bonds in excess of what can be paid from the proceeds of the two-mill continuing tax, and enough to require the levy of the other four mills of water tax to discharge the same, the council must for that year levy that four mills for that very purpose? And, should the council refuse to make such levy, the bondholders might coerce them by mandamus. Therefore, if there were any sense or reason in the doctrine that the borrowing of money by a municipality in anticipation of a special fund, to be collected year by year from a continued tax, from which fund alone the borrowed money is to be paid, does not create an indebtedness, it is apparent that such a case is not presented here. In our judgment, the proposed bonds, if issued, will create an indebtedness against the city of Ottumwa, wholly in violation of the constitution of the state of Iowa.

The orders appealed from are affirmed, with costs.

NOTE. The following is the opinion of the circuit court on granting the first preliminary injunction (July 31, 1901), by McPHERSON, District Judge:

The complainant, a citizen of Maine, has filed its bill in equity against the respondent, a citizen of Iowa, a municipal corporation, and a city of the first class under the laws of Iowa.

1. The jurisdiction of this court is challenged by demurrer on the ground that the amount in controversy does not exceed \$2,000 in amount or value. It is not denied but that the allegations of the bill are in the language of the statute, and in conformity to the forms recognized by all of the courts and the profession. A plea in abatement has also been filed, subject to the demurrer, by which it is claimed that the jurisdictional amount is not in controversy. Complainant is the owner of much property in, and a taxpayer of, the defendant city. Its annual taxes for several years past has been about, but a little less than, \$2,000; and for this reason the city insists that the amount in controversy is too small to confer jurisdiction. But the bill alleges that the city is about to enter into an illegal contract involving the creation of an illegal debt of about \$400,000, of which illegal debt the complainant, if it does not obtain relief in this action, will be required to pay many times \$2,000. And I believe, and so hold, that, both because of the amount of

the debt that complainant will be required to pay and because of the amount of the alleged illegal debt, the court has jurisdiction.

2. The Iowa constitution, among other things, provides (section 3, art. 11): "No county or other political or municipal corporation shall be allowed to become indebted in any manner, or for any purpose, to an amount in aggregate exceeding five per centum on the value of the taxable property within such county or corporation, to be ascertained by the last state and county tax lists, previous to the incurring of such indebtedness." The bill alleges that the last state and county tax list shows that in the city there is \$2,394,890 of taxable property, five per centum of which is, in round numbers, \$120,000. After allowing for all cash on hand, the present indebtedness of the city is a little in excess of this constitutional amount, besides quite large sums which may or may not be valid items of indebtedness, as the proofs may be considered, but which I do not determine, because, without reference to them, the indebtedness not controverted equals that allowed by the constitution, and will be very largely exceeded if the proposed contract sought to be enjoined, if consummated, will create an indebtedness within the meaning of the constitution. It appears that complainant is the owner of and now operates a system of waterworks in defendant city. Evidence as to the manner in which complainant has its waterworks has been presented by both parties. Those matters are not determined. The city council of the defendant city, August 21, 1899, adopted an ordinance No. 566. Section 1 is to the effect that the city elects to erect or purchase a system of waterworks under chapter 5, tit. 5, Code 1897, Laws Iowa. Section 2 provides that for the year 1899 there shall be levied on all the property within the city, excepting lots greater than ten acres in area, used for agricultural and horticultural purposes, a tax of two mills on the dollar. The proceeds of such tax levy for the year 1899, and all subsequent years until the contract or purchase price of the system is paid for, shall be used to create a sinking fund to pay for such system of waterworks. Section 3 provides for a levy of five mills on the dollar on all taxable property within the limits of the benefit and protection of the waterworks to be constructed. The proceeds of the five-mill levy shall, with the rentals of private consumers, be used for expenses, and the excess, if any, shall go into said sinking fund. Section 4 is with reference to a proposed purchase of complainant's property, which is not material to this discussion. Section 5 provides that the engineer shall provide estimates and plans for the proposed system, the making of the contract for the construction, and a vote of the people to affirm or reject such contract. Section 6, as amended, provides for the issuance and sale of sufficient bonds of the city to raise funds with which to pay for the construction of the system. The bonds will bear interest at $4\frac{1}{2}$ per cent., payable semiannually. At the end of two years, \$5,000 of the bonds are payable, and a like sum annually thereafter for twenty-two years. Then the remaining bonds are to be re-funded for a term not exceeding fifty years, making \$10,000 payable annually. The bonds must be sold at not less than par. The proceeds from all the bonds are to constitute a trust fund with which to pay for and construct the works. Section 7 provides that no part, principal or interest, of the bonds, shall be paid out of any fund, levy, or tax other than the five-mill and the two-mill levies aforesaid. During the argument I suggested that it was apparent to me that the bonds never could be paid without going to some other fund, provided the city should not increase in wealth. The answer was made by counsel for the city that the purchasers of the bonds must buy them with knowledge of this fact, and, if the levy would not pay them, they must remain unpaid. I do not recall that I ever before heard of threatened repudiation in advance of the sale of bonds. The bill alleges, and the proofs show, that the plans of the engineer and the specifications for the works show that they can be constructed for \$318,262. It is further made to appear that bids were advertised for. One bid was made, and that at a price in round numbers more than \$80,000 greater than the estimate of the engineer. On such bid a contract has been made. The people at an election are to vote for and against the proposition to carry out this contract. By a restraining order issued, the election has been delayed. The restraining order should not have prevented the election. The election would be the exercise

of political rights, and is so much like the assembling of the people that it should not be denied by the process of the court. But the right or power to issue practically \$400,000 of bonds, to run half a century or more, bearing interest payable twice a year, is a question for the courts, and on application of a taxpayer a court must decide for or against the validity of such proposed bonds. If the proposition is voted in the affirmative by the people, then the bonds may, and will no doubt, be quickly issued, unless restrained by the court. The bonds will, no doubt, be negotiable in form. Innocent purchasers may procure them. Therefore, if this is the creation of an illegal indebtedness, the danger is imminent, and this becomes a proper case for a court of equity. Therefore the question to be decided is, will this contract, if consummated, and the bonds issued, create an indebtedness?

A great many cases have been cited by counsel, which I am asked to consider. With satisfaction to myself, I can omit particular mention of many of the cases cited by making a few suggestions. A great many of those cases relate to special assessments. In all such cases the burden is borne by the property adjacent to the improvement for which the expenditure is made. This is on the theory, now too well established to controvert, that the adjacent property is benefited and enhanced in value equal to the tax or special assessment; and, this being so, the adjacent owners must pay for the improvement. Now, it may be, and in some instances the facts are, that the municipality issues and its officers sign the bonds or evidence of debt. But such evidences of debt are paid off and discharged by money paid by the adjacent owners, and other taxpayers of the city pay no sum whatever. The city acts as agent or trustee in collecting the money from the adjacent owners and in discharging the evidences of debt issued by, and sometimes in the name of, the municipality. And this statement covers all that can be said of any of the special assessment cases cited from Iowa, as well as from other states. Such cases are not in point. They are not authorities on the question now being considered. It is true that excerpts can be taken from many of those opinions, and an argument be made therefrom. But it is taking dictum, instead of taking, as we ought, what the courts in fact decided. I concede that on this question excerpts and dictum can be taken from the many opinions which to some might seem as tending to support the contention of the city in this case. But such an argument is arguing in a circle, and, however, long the argument or the circle, one gets back to the starting point, which is the constitutional provision in question, "No city shall be allowed to become indebted in any manner or for any purpose." And a promise to pay a certain amount, with interest, within a fixed time, out of taxes taken from all the people, including those not benefited, would seem to most people to be a debt. A few of these special assessment cases are the following: *Davis v. City of Des Moines*, 71 Iowa, 500, 32 N. W. 470; *City of Clinton v. Walliker*, 98 Iowa, 655, 68 N. W. 431; *Tuttle v. Polk*, 92 Iowa, 433, 60 N. W. 733. And even on this question there is a conflict. *Fowler v. City of Superior*, 85 Wis. 411, 54 N. W. 800. But I do not care to review the cases on the question of special assessments.

The two gravel-road cases by the Indiana supreme court were cited to me on the hearing as being in point. But they are special assessment cases. The supreme court of Indiana decided the cases on the ground of special benefits equal to the taxation. *Board v. Harrell*, 46 N. E. 124; *Board v. Reeves*, 28 N. E. 995. There is another class of cases containing much dictum that was urged before me, but a class of cases entitled to no consideration in the determination of the case at bar. And they are the cases pertaining to current expenses, such as furnishing light or water. They create no debt, excepting as the light or water is furnished. They are the ordinary expenses of the city. A few of these cases only need be cited as illustrating all of them: *Grant v. City of Davenport*, 36 Iowa, 396; *Creston Waterworks Co. v. City of Creston*, 101 Iowa, 687, 70 N. W. 739. There are many cases like them. The courts have held that, when the city can pay for the water or light from year to year out of its current revenues, such contracts are valid; and then only when the water or light has in fact been furnished, and even on that question the cases are in conflict. In Iowa the cases sustain the validity of such contracts, even though the city is in debt up to the constitutional

limit. But the question here is whether the city of Ottumwa, being in debt up to the constitutional limit, can erect a system of waterworks of its own at an expense of \$398,000, sell its bonds and raise the money with which to make payment, and then in turn pay off the bonds by levy and assessment on all the taxpayers. And on that question the defendant city, by its counsel, has not cited an authority holding such contracts valid. And, broad as the statement is, I do not believe such an authority can be found. Respondent's brief is full of citations. But when they are examined—and I have examined them all—it will be found that they are as follows, without exception: (a) Dictum. Language from opinions which sustains the contention of the counsel for the city. But the dictum is very different from the question in fact decided by the judgment of the court. (b) Special assessment cases, where the city issues the evidence of debt, but where such evidence was to be discharged by the owners of property benefited, and the taxpayers generally did not contribute. And the two Indiana gravel-road cases are no exception. Nor are the two cases from the state of Washington exceptions. *Winston v. City of Spokane*, 41 Pac. 888; *Faulkner v. City of Seattle*, 53 Pac. 365. In those cases the bonds were to be paid for only from the receipts of the waterworks. In all such cases, and in all special assessments, the city is only the agent or trustee to collect the money and pay it over; and the taxpayers generally do not contribute to the payment. (c) Current expenses, such as annual rentals for fire hydrants, when the same is only to be paid for as the water is furnished, and when the same can be paid for out of the current revenues. On this proposition, according to the Iowa cases, the argument of defendant's counsel is sound. But we have no such case here. On the question here presented the cases without conflict, as I read them, hold that the city, when in debt to the constitutional limit, cannot make a valid contract for the erection of some work or improvement with the promise to pay therefor in the future. Such a promise is an indebtedness, and is an indebtedness in its entirety from the time the promises are made. And the constitutional provision in question is an inhibition upon both the legislature and the municipalities of Iowa, and was so intended. And, however shrewd or artful or plausible the proposed scheme may be, legislation by the state or action of the municipality will, when attempting to avoid the constitution, be overthrown by the courts. And to call a tax to pay off such contracts a special assessment or special levy is an attempt to argue the constitution to the winds, in order to succeed in a purpose for a supposed present necessity. And to argue that the project is a necessity is of no avail. The project may be of seeming absolute necessity; and it may be that every taxpayer but one favors the project, but that one taxpayer may resist it. This provision is found in the constitution of several of the states, and the supreme courts of such states have uniformly held as above stated. A few only of these cases I will cite:

In Iowa the latest case is *Windsor v. City of Des Moines*, 110 Iowa, 175, 81 N. W. 476, 80 Am. St. Rep. 280. In that case the contract was for the erection of an electric light plant. The contract was ingenious and plausible. The water rentals were pledged. The payments covered many years. All of the property of the plant was to be mortgaged to secure the bonds. The contract was held to be void, as seeking to create an indebtedness in addition to what the city was already indebted up to the constitutional limit. In *Allen v. City of Davenport*, 107 Iowa, 90, 77 N. W. 532, is a case where bonds were issued on account of street grading. The bonds were declared void, because they sought to create an indebtedness; and this in the face of the fact that the city would get the money, or the greater part of it, back from abutting owners. This is what the case decided. There is much dictum in the opinion to the effect as contended for by the city in the case at bar, and authorities are cited, which do not sustain the dictum. And the same is true of the *Windsor Case* above cited. *Orvis v. Board*, 88 Iowa, 674, 56 N. W. 294, 45 Am. St. Rep. 252: Here was a case with a scheme to make a park district the same in boundary lines as the city, and, making it a distinct corporation from the city, allow the issuance of bonds; and the scheme was much the same as in the case at bar, and the statute under which they were proceeding was much like the statute under

which the city in this case is acting. But it was held to be a scheme, and the indebtedness void. *First Nat. Bank of Decorah v. District Tp. of Doon*, 86 Iowa, 330, 53 N. W. 301, 41 Am. St. Rep. 489, was a case of bonds issued to refund some old indebtedness created beyond the constitutional limit. They were held void. *French v. City of Burlington*, 42 Iowa, 614: This was a case of street grading, and a part of the expenses were to be paid by the abutting owners and a part by the city. It was held to be a debt, and, being beyond the constitutional limit, held to be void. *Mosher v. School Dist.*, 44 Iowa, 122: In this case the school district issued bonds to pay for a schoolhouse. The legislature provided that a lien should exist for materials furnished. Being in excess of the constitutional limit, the bonds and the indebtedness and proposed liens were held to be void. *McPherson v. Foster*, 43 Iowa, 48, 22 Am. Rep. 215, is a case like the *Mosher* Case, and with a like holding. I have not attempted to review these Iowa cases. I have attempted to state what was held in the several cases. In the opinions cited other cases are referred to. And the Iowa cases are uniform in such holdings.

In other states, with like constitutional provisions, we find similar holdings. But I will only refer to the cases. In Kentucky is the case of *Beard v. City of Hopkinsville*, 23 L. R. A. 402, and footnote (s. c. 95 Ky. 239, 24 S. W. 872, 44 Am. St. Rep. 222). *City of Laporte v. Gamewell Fire-Alarm Tel. Co.*, 146 Ind. 466, 45 N. E. 591, 35 L. R. A. 686, 58 Am. St. Rep. 359. In West Virginia, in case of *Spilman v. City of Parkersburg*, 14 S. E. 282. In Illinois are the cases of *Prince v. City of Quincy*, 128 Ill. 443, 21 N. E. 768, and cases cited. In Pennsylvania, in case of *Brown v. City of Corry*, 175 Pa. 528, 34 Atl. 854. In Wisconsin, in case of *Earles v. Wells*, 94 Wis. 285, 68 N. W. 964, 59 Am. St. Rep. 886. And the supreme court, in the cases of *District Tp. of Doon v. Cummins*, 142 U. S. 366, 12 Sup. Ct. 220, 35 L. Ed. 1044, and cases cited. And no case, state or federal, has been called to my attention, and I know of none, that, in my opinion, is in conflict with any of the foregoing cases cited on this point.

The evil that existed, and which evil was corrected by the adoption of the constitutional provision, is known by all. If not so known, one has but to read the debates of the convention of 1857. He will find that many cities and counties in Eastern Iowa—the only part inhabited to a great extent—were in debt hopelessly. In some of those cities and counties the taxpayers are still struggling to pay for improvements, some of which were never constructed. But all such improvements were loudly contended for by the people, as they are at the present day. And the evil was successfully checked, if the courts will but stand by the constitution. But in the case at bar the argument seems to be that the city can go in debt more than the 5 per centum by calling it by some other name than "debt!" It is said that the ordinance provides, and the bonds will so recite, that the money will all be obtained by a "special assessment on all the taxpayers," and that only at the rate of two mills per year; and that, with the surplus of the five-mill levy, and the profits of private consumers, make the burden, not a debt, but a "special assessment." Ordinarily, "special assessments" mean the taxation of abutting property, such as is done for sidewalks, paving, etc. But a special levy of two mills on the dollar on all the property within the city, some of which may be one or more miles from a water main or hydrant, is not a "special assessment," and calling it such does not make it so. The constitution says, "No municipal corporation shall be allowed to become indebted in any manner, or for any purpose, more than five per centum on the last assessment," etc. The words "for any purpose" seems to me to cover a system of waterworks, and the words "any manner" are broad enough to cover "a two-mill levy." If those words do not so mean, then, as I believe, they are utterly without meaning or force. If the provisions can be ridden down by a two-mill levy, then a ten or twenty mill levy per year can be authorized each year for the erection of waterworks, and a like sum for an electric plant, and then for a city hall, and then for parks, and public bath houses, and libraries, and so on, until, under the pretense urged in this case, absolute confiscation can be authorized by the legislature, under the guise of taxation, in one year. But I do not say that the statute under which the ordinance was adopted is not constitutional. If the city were not in debt, and

the proposed improvement cost less than the 5 per cent., there would be no legal objection thereto. Or, if the money was raised in advance, the Iowa supreme court has held there can be no objection. *Youngerman v. Murphy*, 107 Iowa, 686, 76 N. W. 648. But that case does not conclude this point. It will be observed that the *Allen Case*, in the same volume, was decided at a later date. And there is no claim in the *Youngerman Case* that the general rule is overthrown. The validity of another section of the same statute, which provides that a system of waterworks so constructed may be governed by trustees appointed by the judges is now before the Iowa supreme court awaiting decision. The chances are that the court will not look with much favor upon a statute that either commands or allows judges to perform other than judicial duties, and takes from cities their rights of local self-government. Our constitution can be modified or amended by any one of three ways: An amendment can be submitted to the people by two successive legislatures. As to this provision, there has been no such amendment proposed. The legislature can call a constitutional convention. This has not been done. Under the constitution, the people must be asked at the general election every ten years if they want a change. The people have now four times—1870, 1880, 1890, and 1900—said they want no change. Can it not be said that the policy, in force for forty-four years, that the legislature is inhibited from allowing and the municipality from going into debt more than 5 per centum, is not now the settled policy of Iowa?

A temporary injunction will issue as prayed, excepting as against the election.

WRIGHT v. STANLEY.

(Circuit Court of Appeals, Sixth Circuit. December 2, 1902.)

No. 1,063.

1. MASTER AND SERVANT—NECESSITY OF INSTRUCTIONS.

Where an employer sets an employé at work at machinery with the operation of which the employé is not acquainted, and there is a safe way and an unsafe way, the employer, if he has reason to know that the employé is unskilled, is required to give him instructions for operating it in the way by which he will avoid injury.

2. SAME—DANGEROUS MACHINERY—ASSUMPTION OF RISK—EVIDENCE.

While a 17 year old boy, working for the first time at a planing machine, was attempting to pull out the "chaser" from the rear, his foot slipped against the cylinder, which was obscured by a pile of chips and shavings, and was so mutilated that amputation became necessary. In an action against his employer for such injuries, evidence examined, and held for the jury whether he had assumed the risk.

3. SAME—DUTY TO INSTRUCT—INSTRUCTIONS.

In an action for injuries received while working at a planing machine, instructions in regard to the duty of the defendant to instruct plaintiff in the use of the machine examined, and held not objectionable in that they led the jury to understand that defendant became the insurer of plaintiff's safety.

In Error to the Circuit Court of the United States for the Eastern District of Michigan.

Lorenzo T. Durand, for plaintiff in error.

F. T. Cahill, for defendant in error.

Before LURTON, DAY, and SEVERENS, Circuit Judges.

¶ 1. Assumption of risk incident to employment, see note to *Railroad Co. v. Hennessey*, 38 C. C. A. 314.

See *Master and Servant*, vol. 34, Cent. Dig. § 314.

SEVERENS, Circuit Judge. This was an action brought by Stanley, the plaintiff in the court below, to recover damages suffered by him from an injury which he received while at work on a planing machine in a mill of the defendant below, who is the plaintiff in error here, an injury which resulted in the loss of a foot. The plaintiff was a boy 17 years old, who had been employed by the defendant some months before the accident to take care of a horse used about the premises. After being employed in that work for a time, he was directed by his employer to report to the foreman of the mill after his morning's work was done, and occupy his time in service there. Under this direction he had been for a short time occupied in various duties about the mill, though not upon the planing machine until the day of the accident; but he had been about the machine, and had seen this, and other machinery of a different kind, used in the mill, in operation. On coming to the mill that day, he was directed by the foreman to run the machine,—that is to say, to deliver the boards into the machine to be planed,—but not further defining his duties. Near the fore end of the machine were a pair of pressure rollers, one above and one below, between which the board was gripped and carried along to the planing cylinders, one of which was not far behind the rollers and planed the upper surface of the board, and the other about 12 inches from the rear end of the platform of the machine, and located in the bed thereof. This latter cylinder planed the lower surface. There were also pressure bars bearing on the upper surface of the board to hold it down to the work of the cylinder below, and a guide against which the board moved through the machine. The under-running cylinder projected a few inches below the platform, and was run at the speed of 3,500 revolutions per minute. In operating the machine it was necessary that one board should immediately follow another through the machine, otherwise the board in the machine would stop after passing the pressure rollers; so that when the last board of a given piece of work was put through the machine, it was necessary to follow it with a "chaser," or strip of board used only for that purpose. The "chaser" itself would, therefore, have to be taken out before the machine could be readjusted for new work. So far there seems to have been no dispute.

With reference to the other facts there was evidence tending to show that the directions of the manufacturers of the machine provided a method of extricating the "chaser" by certain manipulation of its parts, but that while the plaintiff had been in the mill it was usual for the men operating the machine to pull it out from the rear end by main strength, while the machine was in motion, by laying hold of the "chaser," and putting a foot against the rear end of the platform for advantage in the pulling; and that the plaintiff had seen upon several occasions the fore-end man go back and pull it out in this way, or assist the off-bearing man at that end in getting it out by such means. The under-running cylinder, though set with knives, revolved so rapidly when the machine was in operation that it could not be distinguished from a roller, though some portions of it were in sight to one standing at the rear of the machine. The defendant gave the plaintiff no warning of any danger resulting from its presence, or spe-

cial directions for operating the machine. We have said there was evidence tending to prove these things. It is not to be disputed that other evidence was put into the case tending to refute some or all of the matters thus stated, and which, if we were weighing the facts, might persuade us to a different conclusion as to some of them. But this was the province of the jury, and not of the court, if, as we think was the case here, evidence was given, which, if credited, tended fairly to show such facts, notwithstanding they might have been disputed by evidence more persuasive with the court. The plaintiff, while employed on the machine as above stated, had occasion to run a "chaser" through it. It stopped in the machine, and it was necessary, as the plaintiff supposed, to get it out. Accordingly, he went around to the rear end of the machine, and, seizing the "chaser" with his hands, pressed one foot against the rear end of the platform, and tried to pull it out. The rear cylinder was obscured by a pile of chips and shavings, and he says he did not see it. His foot slipped, and went back under the platform into contact with the cylinder, and was so mutilated that amputation became necessary.

At the close of the evidence the defendant's counsel prayed an instruction to the jury that the plaintiff was not entitled to recover, for the reasons, as then stated: "That under the evidence in the case the plaintiff was guilty of contributory negligence. That the risk was an obvious risk. The plaintiff had an equal opportunity with the defendant to know and appreciate the danger, and that by bracing his foot against that end of the planer and pulling upon the chaser, as shown by the evidence, he was guilty of such contributory negligence as defeated his right to recover." This instruction was refused, and the defendant excepted. Although there are other exceptions, the principal controversy is upon the question whether this instruction should have been granted. We think the court correctly held that the case was such that it was required to submit it to the jury. Appeal is made to the rule as first stated by the supreme court in *Pleasants v. Fant*, 22 Wall. 116, 22 L. Ed. 780, in which Mr. Justice Miller declared the "true principle to be that, if the court is satisfied that, conceding all the inferences which the jury could justifiably draw from the testimony, the evidence is insufficient to warrant a verdict for the plaintiff, the court should say so to the jury." But, gauged by this rule, there was some testimony bearing upon the facts which it was incumbent on the plaintiff to make out to support his action, which, if the jury thought it most worthy of credit, justified the verdict. It is a well-settled proposition that, when the employer sets his employé at new work in conditions of danger not understood or appreciated by the latter, the employer is bound to warn him of the peril. And if the work is to be done by machinery with the operation of which the employé is not acquainted, and there is a safe way and an unsafe way, the employer, if he has reason to know that the employé is unskilled, is required to give him instructions for operating it in the way by which he will avoid injury. This duty is emphasized where, as in this case, the employé is a mere youth; for the presumption of the lack of knowledge and skill on his part is all the greater. We have quite recently

had under review so many cases in which questions of this character have been involved and the rules applicable thereto have been explained and applied that we think it unnecessary to go into extended discussion of the subject. *Ellsworth v. Metheney*, 44 C. C. A. 484, 104 Fed. 120, 51 L. R. A. 389; *Railway Co. v. Miller*, 43 C. C. A. 436, 104 Fed. 124; *Felton v. Girardy*, 43 C. C. A. 439, 104 Fed. 127; *Telegraph Co. v. Burgess*, 47 C. C. A. 168, 108 Fed. 26.

What we have said has equal application to the questions relating to the assumption of risk by the plaintiff and his alleged contributory negligence. But we add that the plaintiff did not assume risks which, from his inexperience and lack of warning and the obscurity of the danger, he could not fairly be regarded as having contemplated. In the circumstances which we have recited, we think it was for the jury to determine whether or not the risk to which he was exposed was of the character which he was bound to assume.

Nearly all of the other matters discussed in his brief and in argument upon the hearing by counsel for the plaintiff in error consist of subordinate points involved in the question already considered as to whether the court should have taken the case from the jury, none of which requires independent consideration.

One other question remains. It is urged that the court, in its instructions to the jury, gave them to understand that the defendant became an absolute insurer of the plaintiff's safety. In order to see whether this objection is well founded, perhaps the best way will be to set forth the instructions which are supposed to have induced the wrong understanding on the part of the jury.

"That is, gentlemen, if Ebert [the foreman] set him at one end of this machine simply to feed in the boards and not to take out the chaser, then he cannot recover; but if Ebert set him to running this machine,—to do this planing,—and it was understood that the man who did the planing took out the chaser, as the plaintiff swears he saw Ebert and other operatives of this machine do, then you would be justified in finding, if you came to that conclusion, that when Ebert set him to putting the boards into this machine and running this planer that he was not only to feed in the boards, but to do the work of the operator of the machine, which would be, he says, to take out the chaser after the last board had been run through. You must find that from the evidence."

"And if you find that Ebert did set the plaintiff at work to run this planer, and it was his understanding that the plaintiff was not only to run the boards through, but the plaintiff was to run the last board through by means of the chaser, and then take the chaser out; and if you find that under all the facts and circumstances in the case it was the duty of Ebert to instruct the plaintiff that the chaser should be taken out by loosening the pressure bar, if you find that was the way in which the chaser was to be taken out when it was found to be fastened so that it required force,—then I instruct you, gentlemen, that you may find it was the duty of Mr. Ebert (if that was not apparent so that any one could see it of ordinary intelligence and the age of this young man) to instruct the young man that to take out the chaser it would be only necessary for him to loosen this pressure bar."

"Gentlemen, if he was put there for the purpose of feeding the boards through, and, after he got through, to take out the chaser, then you could find that it was negligence in Mr. Ebert in not instructing him how to take out the chaser by unscrewing this set screw and relieving it by removing the pressure bar."

"But it is for you to find, under all the circumstances of the case, whether or not it was negligence for Ebert not to instruct him to release this pressure bar, and thereby release this chaser."

These instructions are not, in our opinion, susceptible of the interpretation that the court led the jury to understand that the defendant became the insurer of the plaintiff's safety. We have looked into the charge of the court, which appears to be set forth in full in the bill of exceptions, and think the case was fairly and correctly submitted to the jury.

Finding no error, the judgment must be affirmed.

UNITED STATES v. MULLINS.

(Circuit Court of Appeals, Sixth Circuit. December 2, 1902.)

No. 1,014.

1. INTERNAL REVENUE—RECOVERY OF TAX—EFFECT OF NEGLIGENCE OF OFFICERS.

The negligence of officers in failing to collect a tax on spirits at the proper time, when the spirits were removed from the warehouse, will not preclude the United States from recovering such tax in an action upon the distiller's bond, if it was properly chargeable.

2. SAME—TAX ON DISTILLED SPIRITS—PURCHASE AND WITHDRAWAL BY UNITED STATES.

Packages of distilled spirits purchased by the United States while in a bonded warehouse, and ordered by the secretary of the treasury to be allowed to be withdrawn "free of tax," under the provisions of Rev. St. § 3464 [U. S. Comp. St. 1901, p. 2284], are thereby withdrawn entirely from the operation of the internal revenue laws, and there is no occasion for the regauging and adjustment of the tax thereon, as upon a withdrawal for private consumption, and the distiller cannot be charged with the tax upon a claimed excess of shrinkage therein.

In Error to the District Court of the United States for the Western District of Kentucky.

R. D. Hill, for the United States.

Charles H. Stoll, for defendant in error.

Before LURTON, DAY, and SEVERENS, Circuit Judges.

SEVERENS, Circuit Judge. This cause consists of the consolidation of three actions brought to recover, upon three warehousing bonds executed and delivered by Dwight A. Aiken, as principal, and Alfred R. Mullins, as surety, certain taxes alleged to be due and unpaid on account of a quantity of distilled spirits entered and bonded at the distillery of Aiken, at Lexington, Ky. The bonds were given upon three several entries for the months of March, April and June, respectively, in 1881. On August 9, 1883, the United States having purchased some of the spirits, the secretary of the treasury directed the collector of that district to allow an agent of the United States to withdraw from the warehouse certain numbered packages thereof, "free of tax," for the use of the medical department of the army. The packages mentioned consisted of some of each of the several entries. They were withdrawn accordingly. They were regauged, but there was no provision made for the liquidation of the taxes here in question. All the packages of the several en-

tries were gauged at the time of their deposit in the warehouse, and the tax of 90 cents per gallon assessed against them, as prescribed by law. But at the date of the withdrawal a shortage was found to exist in the packages withdrawn, greater than that which the law permits for deduction on account of shrinkage. This excess of shrinkage amounted to 260 gallons, and the tax thereon, if chargeable, amounted to \$234; and it is for this, with penalty and interest, the government seeks recovery. It does not appear whether the government purchased the spirits of Aiken directly, or from some other person. The burden was on the plaintiff to prove that the purchase was of another person, if it claimed any advantage from such a fact.

The defendants filed an answer to the petition, in which, among other things, it was set forth that Mullins was a surety; that the government had a lien on the spirits for all taxes thereon, and owed him the duty to collect all taxes due on the spirits at the time of the purchase; and that, it having failed to do this, he (the surety) was discharged. The petitioner demurred to this answer. The court sustained the demurrer as to Aiken, and judgment was given for the plaintiff. As to Mullins, the demurrer was overruled. At this stage of the cause the government and Mullins agreed upon a statement of facts to be submitted to the court, without a jury, for judgment. The facts agreed upon were those hereinbefore set out. The court rendered judgment for the defendant Mullins, and the plaintiff brings the case here on writ of error.

Apparently, the court rendered its judgment in favor of the surety upon the ground that he was discharged by the failure of the government to deduct the tax on the shrinkage from the price paid for the spirits at the time of the withdrawal. We think that was a mistake, and that if the tax was chargeable, and the officers who conducted the business should have deducted it, but neglected to do so, the government was not responsible for their negligence. If that be so, neither of the obligors upon the bonds was discharged from liability for the tax, if that was a proper charge. Nevertheless, we are of opinion that the judgment in favor of the defendant Mullins was right for other reasons.

At the time the withdrawal was directed to be made, the tax, although there had been a preliminary gauging, had not yet matured; and the question arises whether the withdrawal for the government of the spirits "free of tax" involved the regauging and the adjustment of taxes, or, in other words, whether any further consideration of taxes upon the packages withdrawn was required. The statute under which the withdrawal was made was section 3464, Rev. St. [U. S. Comp. St. 1901, p. 2284], reading as follows:

"The privilege of purchasing supplies of goods imported from foreign countries for the use of the United States, duty free, which now does or hereafter shall exist by provision of law, shall be extended, under such regulations as the secretary of the treasury may prescribe, to all articles of domestic production which are subject to tax by the provisions of this title."

Counsel have not referred us to any statute giving the privilege mentioned in section 3464. The only one, then or thereafter, and

prior to the date of this transaction, existing, which provided for the purchase and withdrawal of imported goods for the use of the United States duty free, of which we are aware, was section 2514, Rev. St. [U. S. Comp. St. 1901, p. 1695], which was as follows:

"All articles of foreign production needed for the repair of American vessels engaged exclusively in foreign trade may be withdrawn from bonded warehouses free of duty, under such regulations as the secretary of the treasury may prescribe."

This section plainly imports that the articles purchased are withdrawn thereby from the operation of the statute providing for the payment of a duty. Section 3464 extends this privilege of purchasing "duty free" to all articles of "domestic production" which are subject to tax under the internal revenue act. There is no provision anywhere for the readjustment of the tax, such as takes place on withdrawal on private account, and it would be illogical and inconsistent with the purpose of the statute that there should be any such readjustment, the only object of which would be to ascertain whether the tax should be varied. It seems unreasonable to suppose that, the article having been made "tax free," the statute intended that an inquiry should be made to ascertain what tax would be due on account of the article. Regauging was necessary, of course, in order to measure the purchase price.

The argument by which the collection of the tax in question is supported seems technical and highly artificial. It assumes, without reason, as we think, that when the spirits are purchased by the United States the withdrawal is to take place with the same incidents as upon a withdrawal for private purposes. And upon this assumption it is contended that the theory of the transaction is that the government takes account of the tax, charges it up against the owner according to the original measurement, gives him credit for the tax according to the readjustment, and collects the tax on the shrinkage; imputing the shrinkage to the negligence or fraud of the owner. Of course, it is not difficult to see a certain plausibility in all this, if the premises were sound, but it is built up by construction upon an assumption which we think not well taken. It has been often held that, when a statute providing for taxation is of doubtful construction, the doubt is to be resolved in favor of the taxpayer. *U. S. v. Wigglesworth*, 2 Story, 369, Fed. Cas. No. 16,690; *U. S. v. Isham*, 17 Wall. 496, 21 L. Ed. 728; *Hartranft v. Wiegmann*, 121 U. S. 609, 7 Sup. Ct. 1240, 30 L. Ed. 1012; *Twine Co. v. Worthington*, 141 U. S. 474, 12 Sup. Ct. 55, 35 L. Ed. 821; *Rice v. U. S.*, 4 C. C. A. 104, 53 Fed. 910; *Matheson & Co. v. U. S.*, 18 C. C. A. 143, 71 Fed. 394. And such is undoubtedly the English rule. *Partington v. Attorney General*, L. R. 4 H. L. 100. We think that at least it is permissible to say of this doctrine what is said by Cooley in his work on Taxation (page 275 of the second edition):

"But there can be no propriety in construing such a law either with exceptional strictness, amounting to hostility, or with exceptional favor, beyond that accorded to other general laws. It is as unreasonable to sound a charge upon it as an enemy to individual and popular rights, as it is to seek for sophistical reasons for grasping and holding by its authority every subject of taxation which the dragnet of the official force has brought within

its supposed compass. The construction, without bias or prejudice, should seek the real intent of the law; and, if the leaning is to strictness, it is only because it is fairly and justly presumable that the legislature, which was unrestrained in its authority over the subject, has so shaped the law as, without ambiguity or doubt, to bring within it everything it was meant should be embraced."

And it would seem clear that, to warrant the imposition of a tax, the statute should plainly, and not by mere implication from analogies, require it.

Our conclusion upon the subject is that, upon such a withdrawal as took place in the present instance, it is not intended by the statute that the scheme of taxing the article should be pursued, but that the article should upon such withdrawal be freed from all the incidents of taxation.

The judgment will be affirmed.

BASHINSKI et al. v. TALBOTT.

(Circuit Court of Appeals, Fifth Circuit, December 9, 1902.)

No. 1,169.

1. BANKRUPTCY—EXEMPTIONS—ASSIGNED PROPERTY.

A bankrupt may claim his exemptions allowed by the laws of Georgia from the proceeds of a judgment which he assigned to a trustee for the benefit of creditors, although such assignment constituted a preference under the bankruptcy act, where the assignee never made any attempt to obtain the money or any claim thereto, but after the adjudication in bankruptcy it was paid over to the trustee, by direction of the court, by the bankrupt's attorney who had collected the same.

Pardee, Circuit Judge, dissenting.

Petition for Revision of Proceedings of the District Court of the United States for the Southern District of Georgia.

In Bankruptcy. On petition to revise.

Geo. S. Jones (T. S. Felder, C. A. Turner, and Isaac Hardeman, on the brief), for petitioners.

Washington Dessau (Nathaniel E. Harris and Chas. H. Hall, Jr., on the brief), for respondent.

Before PARDEE, McCORMICK, and SHELBY, Circuit Judges.

SHELBY, Circuit Judge. Ellis M. Talbott, the respondent, was the owner of a certain judgment against R. A. Lancaster. Before the proceedings in bankruptcy he made the following transfer of the judgment:

"For value received, I hereby transfer and assign to L. S. Worsham, trustee, all my interest in a judgment obtained in my favor in the case of Ellis M. Talbott v. R. A. Lancaster, Receiver, in the United States circuit court for the Western division of the Southern district of Georgia."

On the 23d of August, 1900, before any collection had been made on this judgment, a petition in bankruptcy was filed against Talbott, and on January 21, 1901, he was adjudged a bankrupt. On February 1, 1902, Talbott (he had been absent from the state of Georgia

for several months) filed schedules and asserted a claim to exemptions. The trustee in bankruptcy set apart to him as exempt several articles, valued at \$37.50, and \$1,562.50 in money, the total exemptions being \$1,600. The creditors filed objections to this allowance of exemptions. The objections were overruled by the referee, and the referee's ruling was affirmed by the district court. 116 Fed. 417. The money which was allowed the bankrupt as exempt was collected on the Lancaster judgment, which had been assigned to Worsham. The case is brought here on petition to revise the decree of the district court, and it is contended that the court erred in allowing the exemptions, because the bankrupt had transferred, prior to bankruptcy, the judgment on which the money set apart to him was collected. It appears from the record that no delivery of the instrument assigning the judgment was ever made to Worsham as assignee of the judgment. The judgment was collected, and the proceeds remained for some time in the hands of R. C. Jordan, the attorney of record for Talbott in the court where the judgment was obtained. Worsham, the assignee of the judgment, never made any effort to reduce the money to his possession. After the proceedings in bankruptcy against Talbott had begun, Jordan, under direction of the court, paid the proceeds of the judgment, less his fee, to the trustee in bankruptcy. Jordan at the time he was directed to pay the money to the trustee held the same as attorney for Talbott.

The following is the statute under which the exemption was claimed and allowed:

"There shall be exempt from levy and sale, by virtue of any process whatever, under the laws of this state, except as hereinafter excepted, of the property of every head of a family, or guardian, or trustee of a family of minor children, or every aged or infirm person, or person having the care and support of dependent females of any age who is not the head of a family, realty or personalty, or both, to the value in the aggregate of sixteen hundred dollars. And no court or ministerial officer of this state shall ever have jurisdiction or authority to enforce any judgment, execution or decree against the property set apart for such purpose, including such improvements as may be made thereon from time to time, except for taxes for the purchase money of the same, for labor done thereon, for material furnished therefor, or for the removal of encumbrances thereon." 2 Code Ga. 1895, § 2827.

This statute was in force when the petition in bankruptcy was filed, and it therefore governs the amount of exemptions to which the bankrupt is entitled. Section 6, Bankr. Act.

It is contended by the petitioners that the effect of the assignment of the judgment is to deprive the bankrupt of any right of exemption in the money collected on it, and that this contention is supported by the supreme court of Georgia in *McDowell v. McMurria*, 107 Ga. 812, 33 S. E. 709, 73 Am. St. Rep. 155. In that case it was decided that a deed made to defraud creditors, though void as to them, is good between the grantor and grantee, and that the former, after executing such deed, has no title to the property thereby conveyed, and therefore cannot have the same set apart and exempted as a homestead under the laws of Georgia. "In attempting to place his property beyond the reach of his creditors," said the court, "he has placed his exemption beyond his own reach." That case was one in which the grantor was guilty of actual fraud. He conveyed his

property to a trustee for the benefit of his children, with the intent and purpose to hinder, delay, and defraud his creditors. The creditors, by suit, sought to avoid the conveyance and condemn the property to the payment of their claims. This appears clearly from the record, although the court said it was "very meager and imperfect." The main point involved in the case was the construction of a decree previously rendered. The decree had adjudged that a certain deed, it having been made to defraud creditors, was null and void, and that it be delivered into court and canceled. The court held that, when nothing more appears, such decree will be construed as declaring the deed to be null and void as to the complaining creditors, and not as adjudicating the invalidity of the instrument as between the parties thereto. This was held on the application of the familiar doctrine that a fraudulent deed, although void as to creditors of the grantor, is good as against the grantor, his heirs, executors, and administrators and parties claiming under the grantor.

But is that principle applicable here to defeat the bankrupt's claim of exemptions? Here there has been no suit against the assignee of the judgment to avoid its transfer. The transfer of the judgment to Worsham was not made to defraud creditors. Its purpose was, as shown by the record, that Worsham should collect the judgment as trustee or agent for Talbott, and pay the proceeds to Talbott's creditors. It does not appear that Worsham ever took any steps to obtain the money collected on the judgment. He asserts no claim to the money. No claim is asserted in this case under the transfer of the judgment. The proceeds of the judgment having come into the hands of the trustee in bankruptcy as the property of the bankrupt, he clearly holds them for administration and distribution under the bankruptcy law, and not under the assignment of the judgment. It would seem to us unjust and contradictory to hold that the funds were the bankrupt's for administration and distribution among the creditors under the bankruptcy law, and yet that the bankrupt was not entitled to exemptions allowed by the same law. Can it be his money under the section relating to its distribution among his creditors, but not his money under the section allowing exemptions?

This is not a case in which the trustee in bankruptcy has sued for and recovered property which had been fraudulently transferred by the bankrupt. In such case it might be contended that a plaintiff who attacked the transfer in equity obtained a lien that would not be displaced by a claim of exemptions asserted after the transfer was avoided by decree. Here no suit has been brought against Worsham, the assignee of the judgment. He has neither held nor asserted any adverse claim against the petitioning creditors. The case is wholly unlike *McDowell v. McMurria*, *supra*.

In *Pendleton v. Hooper*, 87 Ga. 108, 13 S. E. 313, 27 Am. St. Rep. 227, it was held that the claim to exemption was not defeated by the fact that the claimant had parted with the title to his land by a deed of gift, he not having parted with the possession. In that case, Bleckley, C. J., speaking for the court, asked the pertinent question: "How, then, can the land be consistently treated as the property of the debtor for the purpose of subjecting it to sale, and not so treated

for the purpose of exempting it?" See, also, *Whitehead v. Mundy*, 91 Ga. 198, 17 S. E. 287. There are other cases which tend to sustain our conclusion, but we will not lengthen this opinion by quoting or discussing them. *In re Tollett*, 46 C. C. A. 11, 106 Fed. 866, 54 L. R. A. 222; *In re Falconer*, 49 C. C. A. 50, 110 Fed. 111; *Rice v. Nolan*, 33 Kan. 28, 33, 5 Pac. 437.

The statute allows the exemption to the head of a family. It was clearly the intention of the legislature to allow it as a support or benefit to the family of a distressed or insolvent debtor. The statute should be liberally construed to enforce the legislative intent. The courts should be reluctant to deprive the debtor's family of the benefit of the statute, on account of an act of the debtor which does not clearly demand such deprivation. We would, of course, follow the decisions of the supreme court of Georgia in construing the exemption statutes of that state. We find no decision of that court directly applicable to the state of facts presented in this record, but we think the principles announced in some of the cases we have cited tend to sustain our conclusion.

The decree of the district court is affirmed.

PARDEE, Circuit Judge (dissenting). On the 3d of May, 1900, Ellis M. Talbott made the following transfer:

"For value received I hereby transfer and assign to L. S. Worsham, trustee, all my interest in the judgment obtained in my favor in the case of *Ellis M. Talbott v. R. A. Lancaster, Receiver*, in the United States circuit court for the Western division of the Southern district of Georgia. [Signed] Ellis M. Talbott."

On the 25th day of August following I. Bashinski and other creditors of Ellis M. Talbott filed their petition in the bankruptcy court, praying that Ellis M. Talbott might be adjudicated a bankrupt on the ground that he, while insolvent, had transferred certain of his property, to wit, an execution in favor of said Ellis M. Talbott against R. A. Lancaster, and which was evidenced by a decree of the United States circuit court for the Western division of the Southern district of Georgia, amounting to about the sum of \$3,000, which transfer was alleged to be an act of bankruptcy and, as a preference, void under the bankrupt law. Upon this petition the said Ellis M. Talbott was finally adjudicated a bankrupt.

On the 22d day of January, 1901, various delays occurring on account of the nonresidence of said Talbott, he finally filed on the 1st of February, 1902, his schedules, wherein he showed, among other property turned over to L. S. Worsham for the benefit of creditors of Talbott & Palmer, the said judgment in favor of Ellis M. Talbott against R. A. Lancaster, receiver. In the meantime, and while the above proceedings were pending, a trustee was appointed, who, in March, 1901, instituted proceedings against one R. C. Jordan, an attorney at law, to recover from him the proceeds of the judgment in the case of *Talbott v. Lancaster*, which resulted in the recovery from said attorney, as proceeds of said judgment, the sum of \$2,000. Talbott filed his schedules February, 1902, and petitioned to have a homestead set apart to him out of the funds in the hands of the trus-

tee, which application was resisted because in fact the only funds in the hands of the trustee were the proceeds of the Lancaster judgment, which it was alleged had been recovered by the proceeding for the benefit of the creditors.

The following is the finding of fact made by the referee:

"I further find that on the 28th day of May, 1900, the said Ellis M. Talbott did make a transfer to L. S. Worsham, as trustee, to all of his interest in a judgment obtained in his favor against R. A. Lancaster, as receiver in the United States court for the Western division of the Southern district of Georgia, but that the proceeds of said judgment were never recovered by said Worsham, trustee, but that the same were in the hands of R. C. Jordan, one of the attorneys for said bankrupt, at the time the proceedings in bankruptcy were begun; that the said Worsham, trustee, never reduced any portion of the same to his possession; and that by order of the United States court the amount of said judgment was ordered to be paid to the trustee in bankruptcy of said Ellis M. Talbott, and the same was afterwards so paid by the said Jordan."

The judge of the bankruptcy court stated the facts as follows:

"Ellis M. Talbott had recovered by a proceeding in the circuit court a judgment against Lancaster, receiver, amounting to some thousands of dollars. Talbott became involved in his business. That was the business of a broker. He had a partnership with a Mr. Palmer. His firm failed, and to secure his creditors he assigned to a trustee the judgment which he had obtained in the case against Lancaster. The assignment was made in writing, and is as follows: 'For value received, I hereby transfer and assign to L. S. Worsham, trustee, all my interest in the judgment obtained in my favor in the case of Ellis M. Talbott v. R. L. Lancaster, receiver, in the United States circuit court for the Western division of the Southern district of Georgia.' This, it otherwise appears from the evidence, was an assignment for creditors. It is true, I believe, that it was assigned for the creditors of Talbott & Palmer, but Ellis M. Talbott was himself personally bound to pay those debts, and therefore it was, in contemplation of law, an assignment for his creditors. This assignment was made within four months anterior to the proceeding in bankruptcy. It was clearly a preference, and upon the proper issue made by the bankrupt court it was held to be a preference. The money recovered by virtue of the judgment was paid over to the trustee in bankruptcy, and then, after some delay before the referee and in this court, Mr. Talbott files his application for exemption out of this fund."

In *Pendleton v. Hooper*, 87 Ga. 108, 13 S. E. 313, 27 Am. St. Rep. 227, the supreme court of Georgia held that, although title had been parted with, a homestead might still be claimed on the theory of possession; holding that no present interest or estate in land beyond that implied in the fact of possession is requisite to sustain a claim of exemption as against a debt or lien inferior to the exemption right.

In *Whitehead v. Mundy*, 91 Ga. 198, 17 S. E. 287, the above case was cited approvingly, and a homestead allowed in a crop of corn raised on another man's land, on the theory of possession.

In *McDowell v. McMurria*, 107 Ga. 812, 33 S. E. 709, 73 Am. St. Rep. 155, a homestead was denied in a case where creditors had recovered property alleged to have been fraudulently conveyed. The court said:

"Under our statute, a homestead could, on the application of McMurria, only be set apart for the benefit of his family out of his own property. Civ. Code, § 2828. Inasmuch, however, as, prior to his application, the title by his own voluntary act had passed out of him, it follows that such homestead could not legally be granted. This is true whether the deed of conveyance was made with a good or a fraudulent intent. *Cassell v. Williams*, 12 Ill.

387; *Sumner v. Sawtelle*, 8 Minn. 309 (Gil. 272); *Huey's Appeal*, 29 Pa. 219. In *Re Graham*, 2 Biss. 449, Fed. Cas. No. 5,660, the court, ruling on this question, said: 'In attempting to place his property beyond the reach of his creditors, he has placed his exemptions beyond his own reach.' It follows, from what has been said, that the receiver should not have been restrained from the execution of the decree of the superior court of Calhoun county to sell the property, because of the application of *McMurria* for homestead."

In the present case the bankrupt has neither title nor possession, nor any meritorious claim, and, in my opinion, he is not entitled to a homestead out of the funds recovered by the creditors.

Talbott was put into bankruptcy because of the assignment of the Lancaster judgment. Up to the adjudication in bankruptcy there seems to be no pretense that under the law of Georgia he could have been assigned a homestead out of the proceeds of that judgment. In effect, the bankrupt's creditors sued for and recovered the proceeds of the judgment (for it was done by their trustee), and thereupon Talbott applies for and is allowed a homestead out of those proceeds. It would be interesting to know under what law Talbott gets his homestead. It is not supposed that the bankruptcy law allows any homestead to bankrupts except as otherwise entitled. The law of Georgia does not allow a debtor a homestead out of property that he has voluntarily sold and conveyed. An examination of the transcript shows that the pretense that Talbott's assignment to Worsham was incomplete is an afterthought, and without substantial basis in law or fact.

I think the learned judge of the court below and my brethren here have been too liberal with the property that should under the bankrupt law go to Talbott's creditors.

BENT v. HALL et al.

(Circuit Court of Appeals, Fifth Circuit. December 16, 1902.)

No. 1,180.

1. EQUITY—GROUNDS FOR RELIEF—SUFFICIENCY OF BILL.

A bill alleged that complainant made application to the commissioner of the general land office of Texas to purchase a section of school land owned by the state, and that his application was accepted, and he made the payments required by the statute as they came due, until the treasurer refused to receive further payments; that thereafter the land commissioner attempted to cancel his contract, and awarded and attempted to sell the land to another, who conveyed his pretended right to the land to defendants. The bill prayed that defendants be required to produce any writings under which they claimed; that the same be canceled, and complainant adjudged the owner of the land; and for a writ of possession. There was no allegation with respect to the possession of the land, either past or present. *Held*, that such bill did not state a cause of action for relief in equity, since it showed neither title nor possession in complainant to support a suit to remove a cloud from his title, and afforded no basis for a decree against defendants which would be effective to give him either title or possession, or to establish and enforce his contract with the land commissioner, who was not a party to the suit.

Appeal from the Circuit Court of the United States for the Eastern District of Texas.

This is a suit in equity brought by Joseph A. Bent against James N. Hall and wife and L. A. Fuller and wife. The averments of the bill, in substance, are as follows: "That he [plaintiff] is a citizen of the state of California, and that the defendants above complained of are each and all citizens of the state of Texas. That on the 29th of May, 1893, the state of Texas was the owner in fee simple of school section No. 26, surveyed and located under the laws of Texas, for the benefit of the public schools, by virtue of a certificate issued to the Gulf, Colorado & Santa Fé Railway Company. The said section is further described as follows: [Omitting the description of the land.] That on the said 29th of May, 1893, said section of land being isolated and detached from all other public lands belonging to the state of Texas, or any of its various funds or institutions to which lands had been appropriated or set aside, and the records of the general land office of Texas so showing it to be, your orator made application to the commissioner of the general land office of Texas to purchase said section from the state of Texas; it having been previously, in accordance with the provisions of an act of the legislature of Texas approved April 1, 1887, and the acts amendatory thereof approved April 8, 1889, and April 28, 1891, placed on the market at two dollars per acre, in forty equal annual payments; the first payment being thirty-two dollars in cash; the different payments to bear interest at the rate fixed by law. That the application to purchase said land was in due form made in good faith by him, and was accompanied with your orator's obligation to pay the said state the consideration for the said land fixed by its officers, and was accompanied by the first payment of thirty-two dollars; and said land was by said commissioner duly awarded to your orator on the 29th of May, 1893, and your orator's said money was duly received by the treasurer of the state of Texas on the same day, who issued your orator his receipt therefor. That orator paid annually, as and at the time the same became due, the principal due and interest accrued on all the principal to the state of Texas, on his said obligation, up to August 1, 1895, and offered to pay to the treasurer of the state on and previous to said day the amount of principal and interest then due or to become [due], but the said treasurer refused to accept same. That he has since regularly made a tender of all arrearages and all of the principal and interest due on his said obligation, as the same became due, to said treasurer, but they were each and all regularly refused by said treasurer. That orator is informed and believes that the commissioner of the general land office of the state of Texas unlawfully, and in violation of the plaintiff's contract with the state of Texas herein alleged, on February 12, 1895, attempted to cancel same by making an order on the books of his office and otherwise, and by notifying said state treasurer not to receive your orator's proffered payments; that the sale was canceled as erroneously made, and declared same void, and on this account the state treasurer refuses to accept the payments of your orator he offered to pay, and was by the terms of his contract required to make to the state. That subsequently, as your orator is informed and believes, the said commissioner of the general land office of Texas, conniving and colluding with one Lacour, attempted to award and did award and attempt to sell said land to him at the same price and on the same terms as your orator had previously bought same; that such attempted sale was void, and made by said commissioner in direct violation of the law. Orator says that the said Lacour, so he is informed and believes, has conveyed and transferred to the said defendants, or to some one or more of them, for the benefit of all of them, his pretended rights so acquired from the state, in fraud of and disregard of the rights of your orator, and that they, the said defendants, are openly asserting some interest in and to said land, and have frequently claimed to be the owners thereof, and are now depriving your orator of the use, benefits, and revenues and possession of same, to all which he is entitled, and have by their said acts, and the aid and assistance of the said state officers, cast a cloud on his title, and prevented your orator from selling, using, or enjoying same in any way; that your orator made the purchase of said tract of land from the state in good faith, believing that he would get title thereto from the state, and executed his obligation as required by law for the deferred payments, and has always been ready, willing, and able to perform same according to its terms, and still

is; that on or about the 15th day of April, 1895, he offered to pay to the state treasurer the full amount of principal and accrued interest for said land, or any other reasonable act or thing required of him to get a patent to said land, all of which was refused by said treasurer of Texas and commissioner of the general land office of Texas. Your orator further alleges that the said commissioner of the general land office has signified his willingness to reinstate your orator as a lawful purchaser of said land, should the said cloud from his title thereto be removed by a decree of some court of competent jurisdiction in a suit against the defendants hereto; that said tract of land is now of the value of \$12,800. [Omitting prayer for process.] Orator further prays that said defendants may be required to produce such writings, or certified copies thereof, from lawful custodian thereof, or all such originals on which they base their title or claim to said land, and that each and all of such instruments be decreed null and void, and that the same be annulled according to the practice in the courts of equity in like cases, and to stand, perform, and abide by such order, direction, and decree as may be made against them in the premises, as shall be meet and agreeable to equity; that he be adjudged the owner of said land; for a writ of possession and for general relief." The defendants pleaded the statute of limitations of four years and of three years. The court sustained these pleas. The plaintiff declined to amend the bill, and the court thereupon entered a decree that the bill "be, and is hereby, dismissed absolutely." It is assigned here that the court erred in dismissing the bill.

Alex. Bullitt (Rowe & Rowe and Lanier, Bullitt & Wilson, on the brief), for appellant.

Presley K. Ewing (Henry F. Ring and C. F. Stevens, on the brief), for appellee.

Before PARDEE and SHELBY, Circuit Judges, and BOARMAN, District Judge.

SHELBY, Circuit Judge, after stating the case as above, delivered the opinion of the court.

Without examining the ground on which the circuit court proceeded, we are of opinion that the bill was rightly dismissed. The land in question was the property of the state of Texas. The plaintiff proposed to buy it. His application was accepted, and he made a small payment on the purchase money. He never obtained any patent or other conveyance of title. Subsequently the commissioner of the general land office of Texas "attempted to cancel" the contract with plaintiff, and "attempted to award and did award and attempt to sell" the same land to one Lacour. Lacour has conveyed his "pretended right" or claim to the defendants. The plaintiff, having stated these facts in his bill, prays that the defendants may be required to produce such writings, or certified copies thereof, from lawful custodian thereof, or such originals on which they base their title or claim to said land, and that the same be canceled, and that he (plaintiff) be adjudged the owner of said land, and for a writ of possession. It does not appear from the bill that the plaintiff is now, or ever was, in possession of the land; nor is it shown that the defendant is in possession, or ever was in possession, of the land. There is a prayer for a writ of possession, but it does not appear who is to be ousted from possession. No one is shown to be in actual possession. There is nothing alleged to prevent the plaintiff from taking actual possession as against the defendants. The legal title to the land appears from the bill to be in the state of Texas, but we are not advised by the bill as to any actual possession,

past or present. On these averments, the question arises, what is the court asked to do that it can do? It is asked for a writ of possession, but, conceding that such writ may issue in a case where equity has jurisdiction, it is not shown that any one of the defendants is holding possession. It is not shown that any one is holding possession against the plaintiff. The plaintiff prays the court to adjudge him "the owner of said land," but the bill does not show the plaintiff to be the owner in the sense of having the legal title, nor that he has a complete equity, in the sense that he has paid the whole of the purchase money. We cannot hold the bill to be one for specific performance, because, whatever rights the plaintiff may have, on the averments of the bill, against the state of Texas, he shows no right to specific performance of any contract with the defendants. No contract of plaintiff with them is alleged. If an owner of land make a valid contract to convey it to one purchaser, and subsequently another contract to convey to another purchaser, the first purchaser may maintain a bill for specific performance against the owner, making the second purchaser also a defendant; and he may obtain not only a specific performance of the first contract of sale, but a cancellation of the second contract of sale. But we have no such case here.

Unless the bill can be sustained as one to remove cloud from the plaintiff's title, it certainly has no equity. Looking at it as a bill to remove cloud from the title, the prayer is that the defendants be required to produce their title or claim, that the same may be canceled. The only paper they are shown to have is the conveyance or transfer from Lacour. If that paper were produced and canceled, what good would it do the plaintiff? It would give him neither possession nor title. It would not change his contractual relations with the Texas land commissioner. The decree would be ineffectual. If it prevented Lacour's vendees from completing their purchase of the land by making the deferred payments, it would not secure the land for the plaintiff, nor in any way enforce his alleged agreement with the Texas land commissioner. It would not revive his contract, if legally canceled; nor would it settle its validity before cancellation, as against the land commissioner. The plaintiff seems to appreciate this difficulty, and, to avoid it, he alleges that the commissioner of the general land office has "signified his willingness to reinstate your orator as a lawful purchaser of said land, should the said cloud from his title thereto be removed by a decree of some court of competent jurisdiction in a suit against the defendants hereto." The effect of the decree that the court would render would depend on the willingness or unwillingness of the land commissioner to reinstate the plaintiff as purchaser. If he did not consent to abide by the decree, it would not bind him. It is clear that, if the plaintiff cannot enforce the specific performance of his original contract against the commissioner (a question not before this court), he could not enforce the commissioner's agreement about the effect that he would be willing to give the decree. Under the jurisdiction and practice in equity, independently of statute, a bill to remove cloud on title, which avers no facts conferring the right to other equitable relief, must show that the plaintiff has the legal title to the land, and that he is in possession. The bill "cannot be maintained without clear

proof of both possession and legal title in the plaintiff." If plaintiff's title is legal, and he is out of possession, his remedy is at law, by ejectment. If his title is equitable, and not such title as will support ejectment, he must acquire the legal title and bring ejectment. *Frost v. Spitley*, 121 U. S. 552, 556, 7 Sup. Ct. 1129, 30 L. Ed. 1010; *U. S. v. Wilson*, 118 U. S. 86, 89, 6 Sup. Ct. 991, 30 L. Ed. 110; *Herrington v. Williams*, 31 Tex. 448, 460; *Chinn v. Taylor*, 64 Tex. 385, 390.

The decree of the circuit court will be amended so as to make the dismissal of the plaintiff's bill without prejudice, and, as so amended, it is affirmed.

HUDSON v. MERCANTILE NAT. BANK OF PUEBLO, COLO.

(Circuit Court of Appeals, Eighth Circuit. November 19, 1902.)

No. 1,772.

1. BANKRUPTCY—DISCHARGE—CONCEALMENT OF PROPERTY.

A bankrupt furnished the money with which two tracts of public land were acquired, one by his son and the other by a third person. After the land was patented such third person conveyed his tract also to the son at the bankrupt's instance and without consideration. The land had previously been occupied for a number of years by the bankrupt as a part of his ranch, and he continued to occupy and use the same afterwards without accounting for rents or profits to the son, who did not reside upon the land, but had removed to Mexico even before the title was acquired. *Held*, that either a trust resulted in favor of the bankrupt from his payment of the consideration which he could enforce, or, if the conveyance to the son was for the purpose of defrauding creditors, he held it on a secret trust for the bankrupt, and in either case it was the bankrupt's duty to schedule the land as a part of his estate, and his failure to do so amounted to a fraudulent concealment of property from his trustee, within the meaning of Bankr. Act 1898, § 14b [U. S. Comp. St. 1901, p. 3427], which justified the court in refusing him a discharge.

Appeal from the District Court of the United States for the District of Colorado.

J. E. Rizer, for appellant.

Henry A. Dubbs (Henry Hunter, on the brief), for appellee.

Before CALDWELL, SANBORN, and THAYER, Circuit Judges.

THAYER, Circuit Judge. This is an appeal from an order made by the district court of the United States for the district of Colorado whereby Joshua B. Hudson, who was adjudicated a bankrupt on his own petition on June 4, 1900, was denied a discharge. Numerous specifications were made by his creditors in opposition to a discharge, most of the specifications being, in substance, that the bankrupt had willfully made false oaths in certain respects, in the course of the proceedings in bankruptcy; but by the tenth specification in opposition to his discharge it was alleged that the bankrupt had "willfully concealed from his trustee, while a bankrupt, certain property belonging to his estate in bankruptcy," which property so concealed was specifically described, and consisted of three quarter sections of land in Huerfano county, Colo., and a herd of cattle upon said land, all of

which property, as it was averred, belonged to the bankrupt, and had not been scheduled as a part of his estate, as it ought to have been.

The facts disclosed by the record, concerning which there is practically no dispute, are these: The schedules which he filed show that he owed debts to the amount of \$58,142.39, and that his assets, all of which he claimed as exempt, amounted to only \$1,680. Since the year 1885 the bankrupt has been in possession of a ranch in Huerfano county, Colo., consisting of four quarter sections of land, each containing 160 acres. The ranch is said to be of a value exceeding \$20,000. The land composing it was entered in the year 1889 by four different persons, namely, Stephen D. Curtis, Ira Hatch, Maggie Craig, and Isaac W. Hudson, the latter being the bankrupt's son. The land was entered by the persons aforesaid at the instance of the bankrupt, and with money furnished by him for that purpose. He had previously occupied the land either in whole or in part under what are termed "squatters' rights," which he had acquired in the name of his son I. W. Hudson, who is commonly called Walter. At the present time, by virtue of various conveyances that have been made, by the bankrupt's direction, since the land was entered, the record title to the four quarter sections composing the ranch is as follows: The record title to two of the tracts is in the name of the bankrupt's son Walter, the record title to another tract is in the name of his son Tim Hudson, while the record title to the remaining tract is in the name of the bankrupt and is held by him as a homestead. The homestead and the two tracts standing in the name of his son Walter are the most valuable parts of the ranch. One of the tracts, the title to which now stands in the name of Walter Hudson, was the tract which was originally entered in the name of Craig. It was conveyed by Craig to Stephen D. Curtis, without the latter's knowledge, in the year 1893, by direction of the bankrupt. Several years later Curtis was advised of the conveyance, and at the bankrupt's instance and without consideration Curtis conveyed the land which he had so acquired from Craig to Walter Hudson. The last-mentioned deed was withheld from record until November, 1899, being all the time in the bankrupt's custody.

Since the year 1885 the bankrupt has occupied the ranch and dealt with it as his own, applying whatever was realized therefrom to his own use and benefit. Walter Hudson went to Arizona in the year 1884, and engaged in the cattle business in that territory, which business proved to be unprofitable, and in the course of his cattle transactions he appears to have become largely indebted to his father. He returned from Mexico, where he subsequently went and where he now resides, when the time arrived to complete the filing on the two tracts of land which now stand in his name, and then returned to Mexico, and has not been on the ranch since 1895, and has never in fact paid any attention to it since his father's occupancy began.

If any one of the numerous specifications in opposition to the bankrupt's discharge is well pleaded and is sustained by the evidence, it follows, of course, that the order refusing a discharge must be affirmed, since it is not required of any one who objects to a bankrupt's discharge that he shall maintain all of his specifications in opposition thereto. It is unnecessary, therefore, to consider any of the matters

that are alleged in opposition to the discharge save such as appear to be well founded in fact and in law. We have reached the conclusion, after a careful perusal of the record, that the two quarter sections of land, the title whereto now stands in the name of Walter Hudson, are in fact the property of the bankrupt, and that they have belonged to him since their acquisition from the government. We are constrained to believe that as between the bankrupt and his son it has always been well understood that the title to the two tracts of land in question is held in trust by the son for the sole benefit of the father, and that the legal title so held by the son is subject to sale or other disposition, as the bankrupt may desire or direct. As this is purely a conclusion of fact, it would subserve no useful purpose to review the testimony in detail upon which the conclusion is based. It will suffice to say that we have been forced to conclude that Walter Hudson is a mere naked trustee of the title to the two tracts of land, by the manner in which the land was originally acquired by the bankrupt, by the manner in which it has been occupied and used by him for the past 15 years, by his failure to account to any one during that period for the rents and profits of the land, by the failure of the holder of the legal title to call upon the bankrupt for any account of the rents and profits, and by his taking up his abode in a foreign country, and by his failure to exercise any visible acts of ownership over the property since the title was placed in his name. These facts and circumstances in themselves, if there were no others, are quite sufficient, we think, to warrant the belief that Walter Hudson has no interest in the property in question, and that the bankrupt is the real owner and entitled to do with it as he pleases. Such appears to have been the view of the trial court, and we fully concur in that opinion. Moreover, as the land in question was purchased with money provided by the bankrupt, we are of opinion that the facts to which we have adverted rebut the presumption that a gift to the son was intended when the legal title was placed in his name, and that even as between the bankrupt and his son a trust would result in favor of the former, by operation of law, and that he could most likely compel a conveyance of the legal title to himself. On the state of facts presented by this record, we are disposed to hold that a resulting trust could be enforced by the bankrupt. At all events, such a trust could be enforced unless the title to the land was vested in Walter Hudson with a view of hindering, delaying, or defrauding the bankrupt's creditors, in which event, as a matter of course, a constructive trust would arise in favor of the creditors, which would prevent the enforcement of a resulting trust. On the oral argument, however, it was contended by counsel for the bankrupt that he was so far solvent when the title to the land was vested in his son that the act of taking the title in the latter's name did not operate as a fraud upon creditors nor create a constructive trust in their favor. If we accept that view as sound, it follows, of course, that the doctrine of resulting trusts may be applied to the case; and in that event the bankrupt is in a situation to compel a conveyance of the legal title to himself because, as before stated, the circumstances of the case are sufficient to rebut the presumption that a gift to the bankrupt's son was intended. They show rather that the title to the land was placed in the son's

name merely as a matter of convenience, and that it has always been held by him as a naked trustee subject to the control of the bankrupt and to be dealt with as he might direct.

We are of opinion, therefore, in view of what has been said, that it was the bankrupt's duty, when he filed his schedules in bankruptcy, to have included the two quarter sections of land standing in the name of his son Walter Hudson as a part of his property; and the fact that he did not do so, taken in connection with the fact that the record title stood in the name of his son, amounts, we think, to a willful and fraudulent concealment of property from his trustee within the purview of section 29 of the bankrupt act [U. S. Comp. St. 1901, p. 3433]; and the act in question being an offense under the latter section, it constitutes sufficient ground for refusing a discharge under subdivision b of section 14 of the bankrupt act [U. S. Comp. St. 1901, p. 3427]. It has been held on several occasions by courts of bankruptcy that where a person, prior to filing a petition in bankruptcy, conveys the whole or a part of his property to a third party to be held in secret trust for himself, and fails to schedule it as a part of his assets, such an act amounts to a fraudulent concealment of assets which will defeat his right to a discharge. In *re Welch* (D. C.) 100 Fed. 65; In *re Bemis* (D. C.) 104 Fed. 672; In *re Becker* (D. C.) 106 Fed. 54. In the case at bar, as already shown, the bankrupt either has a resulting trust in the two tracts of land in question, which arose without fraud, or Walter Hudson holds the land in secret trust for the benefit of the bankrupt, the trust having been created to defraud creditors; and in either event, as it seems, the land ought to have been scheduled by the bankrupt as a part of his estate, and his failure to do so amounts to a concealment of assets.

We are also strongly inclined to the view, after reading the evidence, that the bankrupt had such an interest in a herd of cattle, some 200 in number, that are now in the possession of a third party, as ought to have been scheduled as a part of his estate; but, as we have concluded that a discharge was properly denied because the bankrupt failed to schedule the land which stood in the name of his son Walter, it is deemed unnecessary to decide definitely whether his interest in the cattle was of a nature that ought also to have been scheduled.

The order denying a discharge is accordingly affirmed.

ROBERTS et al. v. LANGENBACH et al.

(Circuit Court of Appeals, Sixth Circuit. December 2, 1902.)

No. 1,123.

1. FEDERAL COURTS—ISSUES ON JURISDICTIONAL ALLEGATIONS—MANNER OF TRIAL.

Where a jurisdictional allegation in a plaintiff's pleading in an action at law in a federal court is denied by the answer, and the code practice of the state requires matters in abatement to be pleaded by answer, an issue of fact is thus joined, which is to be tried with the other issues, although it should be submitted to the jury for a separate finding distinct from that on the other issues.

In Error to the Circuit Court of the United States for the Western District of Kentucky.

Charles L. Jewett, for plaintiffs in error.
Henry Burnett, for defendants in error.

Before LURTON, DAY, and SEVERENS, Circuit Judges.

SEVERENS, Circuit Judge. This is a controversy between rival claimants to the possession of a tract of land in Kentucky supposed to contain mineral oil. The plaintiffs in the court below claimed possession under a lease of the premises from W. H. Mann, who was the owner, bearing date May 22, 1900. The defendants claimed under a lease from the same lessor dated September 2, 1901; their contention being that the former lease had before that time been forfeited and abandoned by the lessees, whereby the owner was privileged to grant the later lease to them. The petition set forth the former lease, and the rights claimed to have inured under it,—among them, the right to the possession of the leased land,—and alleged the forcible expulsion of the petitioners from the possession by the defendants under claim of right secured by the second lease; and the petitioners prayed for restitution of the possession of the premises. In founding the jurisdiction, the petition stated that the right claimed was of the value of \$2,000, exclusive of interest and costs. The defendants, answering, denied in general the right claimed by the petitioners, and the forcible expulsion charged, and denied that a sum amounting to \$2,000 was involved in the controversy. Upon the trial the defendants proposed to prove and offered evidence in support of their answer in respect to the amount or value involved in the controversy, as affecting the jurisdiction. This was objected to by counsel for the plaintiffs. The objection was sustained by the court, and defendants excepted. The reason for this ruling is not stated in the bill of exceptions, but we are advised by the opinion of the trial court that it was upon the ground that, being a plea to the jurisdiction, it was a preliminary question to be tried by the court, and was not for the jury. A doubt was expressed whether the plea was good, but the answer to that part of the plaintiffs' petition relating to this subject was not demurred to. Moreover, it was an express denial of the allegations of the petition in that behalf, and surely, if the petition was sufficient, the answer was. We do not doubt, however, that each was sufficient as a pleading. The question upon this branch of the case, therefore, is whether the court was right in holding, as it apparently did, that the answer should, in this respect, be treated as a plea to the jurisdiction, which should be first tried by the court without a jury.

Pleadings in Kentucky are regulated by a Code, and by that the old distinctions in regard to pleading, between matters which would abate the action and those which would defeat it on the merits, are superseded. The defendant may, by answer, present defenses of either kind or of both kinds, and he may have a trial by jury of any issue of fact so presented. Probably the court had in mind the practice prevailing under the common law, where it was held that such an objection as this must be pleaded in abatement and be first determined. *Sheppard v. Graves*, 14 How. 505, 14 L. Ed. 518. Even then, if an issue of fact arose upon such a plea, it was triable by jury.

But it has been held, since the old system of pleading was superseded in many of the states by a code of practice, and the passage of the act of congress requiring the courts of the United States to conform to the modes of the state practice in the trial of actions at law, that the defendant may plead by answer facts which would defeat the jurisdiction; and, indeed, that is the only proper way in which it may be done under the code practice in general. Pom. Code Rem. § 721. A very similar question was presented to the supreme court in *Roberts v. Lewis*, 144 U. S. 653, 12 Sup. Ct. 781, 36 L. Ed. 579. In that case, which was tried under the regulations of the Nebraska Code of Practice, the petition stated that the parties were citizens of different states, specifying them. The defendant's answer was a general denial. It was held that this put in issue the citizenship of the parties, and, for the reason that the record showed no proof or any finding upon that issue, the judgment, which was for the plaintiff, was reversed. The change, which had resulted in the practice of the federal courts in several states from the adoption of codes, was fully explained in the opinion by Mr. Justice Gray.

Doubtless the court should take measures upon the trial to present the several issues of fact to the jury distinctly, so that their finding may distinguish their conclusions upon each as the necessities and justice of the case may require. In the case of *Ashley v. Board*, 8 C. C. A. 455, 60 Fed. 55, this court was required to deal with a similar question. The record showed no issue upon the question of the bona fides of the citizenship alleged, but it did show that evidence was given upon the trial which raised a doubt upon that question. The jury had rendered a general verdict for the defendant. In reviewing the judgment for errors touching the merits, we pointed out the necessity for keeping the issues in such a case distinct, and requiring the verdict to respond to them; and we also directed that an amendment of the pleading might be made so as to present the question referred to, whereupon a separate verdict by the jury could be taken, or the court might determine the question for itself under the act of 1875. But the question here involved does not arise under the act of 1875, which gives to the court the power to dismiss the cause at any stage where it is convinced that a fraud upon the jurisdiction is being practiced, but arises in the regular course of pleading upon an issue in terms presenting it, quite independently of that act.

We shall pursue the course adopted by the supreme court in *Roberts v. Lewis*, above cited, and, refraining from expressing any opinion of the merits at the present time, reverse the judgment, and remand the case to the circuit court for further proceedings in accordance with the opinion of this court. It is so ordered.

On Petition for Rehearing.

(January 6, 1903.)

PER CURIAM. In this cause a petition for rehearing has been filed. It is pressed upon us that our opinion is in conflict with the decision of this court in *Butchers' & Drovers' Stock Yards Co. v.*

Louisville & N. R. Co., 14 C. C. A. 290, 67 Fed. 35, in which it was held, citing *Wickliffe v. Owings*, 17 How. 47, 15 L. Ed. 44, that a denial of the fact that the requisite amount to support the jurisdiction is involved could not be set up in an answer, but must be pleaded in abatement. There is, however, no such conflict as counsel supposes. The case referred to was a suit in equity. The bill alleged the necessary fact, and there was no special plea in abatement; but the alleged fact was denied by the answer. The case was similar in this respect to that cited from the supreme court. The pleading and practice of the circuit courts of the United States in equity are not affected either by the alteration of the codes of the states which have adopted them, as has been constantly held, or by the act of congress requiring the United States courts to follow the method of procedure in the courts of the states, suits in equity being expressly excluded by the act. Hence that decision.

The case we have at hand is an action at law. By the code of Kentucky matter in abatement and defenses going to the merits are to be pleaded in the answer. The circuit court was required to follow that method of procedure. As was said by Mr. Justice Bradley in *Amy v. City of Watertown*, 130 U. S. 301, 304, 9 Sup. Ct. 530, 531, 32 L. Ed. 946: "The statute of 1872 is peremptory, and whatever belongs to the three categories of practice, pleading, and forms and modes of proceeding must conform to the state law and the practice of the state courts, except where congress itself has legislated upon a particular subject and prescribed a rule." These considerations ought to make the distinction between our former decision and the present clear.

It was incumbent upon the defendants to deny in their answer the allegation of the petition in respect to the value of the matter in controversy, if they desired to put it in issue; for, although in the state court such an allegation not accompanied by an allegation of an express promise, or by a statement of facts showing an implied promise, to pay such value, would not be regarded as so far material that it would be necessary to deny it in order to put the plaintiff to his proof (see Code Ky. § 126), yet in the United States circuit courts, the jurisdiction being limited by the requirement that a certain sum must be involved in the controversy, the rule is otherwise. The allegation is material and necessary, and without it the petition would be demurrable.

There is no other ground suggested for a rehearing that has not been fully considered in the opinion hitherto filed.

The petition for rehearing is denied.

FITZPATRICK et al. v. GRAHAM.

(Circuit Court of Appeals, Second Circuit. December 15, 1902.)

No. 134.

1. WRIT OF ERROR—JOINDER OF ALL DEFEATED PARTIES.

To give the circuit court of appeals jurisdiction to review a joint judgment against all the defendants in ejectment, it is necessary that all the defendants join in the writ, or a severance of interest be effected and made to appear in the record.

2. SAME—WHAT CONSTITUTES JOINDER.

Two of the defendants against whom a joint judgment had been rendered failed to join in the petition for a writ of error, though the application for the writ was made by the attorney of record for all the defendants, who resisted unsuccessfully an order of the trial court striking from the writ the names of the defendants in question. *Held*, that as it was unnecessary that all the defendants join in the petition for the writ, but the joinder in the writ was sufficient to make them parties thereto, and as the trial court was without jurisdiction to amend the writ, they became and remained parties, so as to confer jurisdiction on the circuit court of appeals.

In Error to the Circuit Court of the United States for the Southern District of New York.

For opinion below, see 116 Fed. 1021.

Bayard L. Peck, for plaintiffs in error.

Sackett & McQuaid, for defendant in error.

Before WALLACE, LACOMBE, and TOWNSEND, Circuit Judges.

WALLACE, Circuit Judge. The motion of the defendant in error to dismiss the writ of error proceeds upon the theory that two of the defendants in the court below are not joined as plaintiffs in error in the writ. As the action was ejectment, and the judgment sought to be reviewed by the plaintiffs in error was a joint judgment against all the defendants for a recovery of possession and of mesne profits and costs, it was necessary that all the defendants should join in the writ. This court does not obtain jurisdiction to review such a judgment unless all the defendants have joined in the writ of error, or unless a severance in interest has been effected and made to appear by the record. *Masterson v. Herndon*, 10 Wall. 416, 19 L. Ed. 953; *Feibelman v. Packard*, 108 U. S. 14, 1 Sup. Ct. 138, 27 L. Ed. 634; *Ayres v. Polsdorfer*, 45 C. C. A. 24, 105 Fed. 737. It appears, however, that all the defendants are named in the writ as plaintiffs in error, and the contention that two of them are not joined rests solely upon the ground that these two did not join in the petition presented when the writ was granted, and that the court below upon the motion of the plaintiff made an order striking from the writ the names of the two defendants who did not join in the petition. Although all the defendants did not join in the petition, the application for the writ was made by the attorney of record for all the defendants named in the writ, and he did not consent to the order of the court below

¶ 1. See Appeal and Error, vol. 2, Cent. Dig. §§ 1802, 1806, 1811.

striking out the names of the two defendants who had not joined in the petition, but opposed the granting of the motion. It is not necessary that the application for a writ of error be founded upon petition, and the writ is valid notwithstanding any defect or insufficiency in the petition. The approval of a bond and the signing of a citation is a sufficient allowance of the writ. *Scott's Adm'r v. Stockton*, 41 U. S. App. 579, 18 C. C. A. 408, 72 Fed. 1; *Davidson v. Lanier*, 4 Wall. 447, 18 L. Ed. 377; *Ex parte Virginia Com'rs*, 112 U. S. 177, 5 Sup. Ct. 421, 28 L. Ed. 691. It follows that the fact that the names of two of the defendants who are joined in the writ of error do not appear in the petition is of no importance. Whether their omission to join in the petition was an oversight, or whether it was purposely made, are inquiries of no moment, inasmuch as their attorney concluded to join them in the writ with the other defendants. Having been joined in the writ, they remain joined notwithstanding the order of the court below striking out their names. A writ of error is a new suit in the appellate court, and the writ having been duly granted, and due service having been made, the order was a nullity because the court had no power to make any amendment of the writ. The power to amend a writ of error resides exclusively in the appellate court. *Rev. St. U. S. § 1005* [U. S. Comp. St. 1901, p. 714]; *Insurance Co. v. Pendleton*, 115 U. S. 339, 6 Sup. Ct. 74, 29 L. Ed. 432; *Butchers' Ass'n v. Slaughterhouse Co.*, 1 Woods, 50, Fed. Cas. No. 2,234; *Pearson v. Yewdall*, 95 U. S. 294, 24 L. Ed. 436; *Draper v. Davis*, 102 U. S. 370, 26 L. Ed. 121; *Keyser v. Farr*, 105 U. S. 265, 26 L. Ed. 1025.

The motion is denied.

THOMSON-HOUSTON ELECTRIC CO. et al. v. NASSAU ELECTRIC
R. CO. et al.

(Circuit Court of Appeals, Second Circuit. November 6, 1902.)

No. 2.

1. APPEAL—DISMISSAL—LACK OF SUBSTANTIAL CONTROVERSY.

An appeal from an interlocutory decree finding infringement of a patent presents for review only that part of the decree granting an injunction, and will be dismissed where it is shown that the controversy between the parties in respect to the injunction has been settled.

Appeal from the Circuit Court of the United States for the Eastern District of New York.

On Motion to Dismiss Appeal.

F. H. Betts, for appellants.

John R. Bennett, for appellees.

Before WALLACE, TOWNSEND, and COXE, Circuit Judges.

PER CURIAM. As the appeal in this cause is from an interlocutory decree, it lies only to that part of the decree which grants an injunction, and if there is no longer any controversy between the parties touching the right of the complainant to enjoin the infringement

alleged in the bill the appeal presents no real controversy for decision. The counsel for the appellant has very properly called the attention of the court to that part of the record which discloses the present relation of the parties to the controversy, and indicates that it has been settled, except as it relates to a recovery of profits and damages, and the statement and documents submitted by counsel for the appellee substantiate what appears in the record.

As there is no real and substantial controversy still existing between the parties which is presented by the appeal, the court ought not to hear the appeal. The appeal is accordingly dismissed.

SANFORD MILLS v. MASSACHUSETTS MOHAIR PLUSH CO. et al.

(Circuit Court of Appeals, First Circuit. November 12, 1902.)

No. 427.

1. PATENTS—INVENTION—PROCESS FOR MAKING PLUSH.

The Goodall patent, No. 605,710, for an improved process of making frisé plush, the essential steps in which are a thorough sizing of the fabric on both sides, and the drying of the size before embossing, is void for lack of patentable novelty, in view of the prior art, and also for direct anticipation.

Appeal from the Circuit Court of the United States for the District of Massachusetts.

Suit for infringement of letters patent No. 605,710, for a process for making frisé plush, granted to George B. Goodall June 14, 1898. From a decree dismissing the bill, complainant appeals.

The following is the opinion of the circuit court (LOWELL, District Judge):

This was a bill in equity for the infringement of letters patent No. 605,710, for an improved process of making frisé plush. The two claims of the patent are as follows:

"(1) The herein-described method of producing plush fabric showing at its face a figure or design, which consists in sizing the uncut pile-loops; drying said sized fabric; depressing or crushing down below the level of adjacent pile-loops a portion of said dried, sized, uncut loops, thus leaving some of the sized and dried loops standing and stiff and others depressed; cutting the standing loops to form the plush face; and removing the size from the fabric, which softens the same, and permits the previously-depressed uncut loops of pile to rise and show uncut loops in a field of cut loops in design,—substantially as described.

"(2) The herein-described method of producing plush fabric, which consists in heavily sizing the uncut pile-loops forming the face of the fabric; drying said heavily-sized pile-loops, rendering them stiff for standing against the cutting operation; cutting the loops to form the plush face; and removing the size, leaving the cut loops soft and pliable, substantially as described."

Frisé plush is a plush fabric in which the uncut loops form a pattern on a background of ordinary cut plush, or conversely. Frisé plush had usually been made upon a pattern or Jacquard loom, an expensive, though accurate and otherwise satisfactory process. Not a few attempts had been made to produce the same result by cheaper means, and nearly all the experiments were made in this general fashion: After the plush had been woven in the loop, the figures which were to remain uncut were depressed by embossing,

leaving the loops which were to be cut so as to form the ground standing up above the figures thus depressed. The uncut part thus left standing was then cut, commonly by a reciprocating machine like a lawn mower. The depressed figures were then raised, and the pattern appeared, formed by uncut loops on a ground of cut plush. The fabric thus made was not satisfactory, the outline of the figures being imperfect and ill-defined. Moreover, by reason of the clipping of the cut plush by a reciprocating cutter these uncut figures usually projected somewhat above the cut plush ground. The complainant's process meets this difficulty by sizing heavily and on both sides the whole fabric when uncut and fresh from the loom. The sized fabric is then dried, leaving all the loops standing upright and stiff. The figures are then depressed upon this stiffened fabric by embossing with a heated stamp, which softens the sizing beneath it, and glues the depressed loops to the back of the fabric. The upright loops are then cut, not by a reciprocating machine, but by rotary, vertical knives, so that the height and length of the cut pile is increased, rather than diminished, by the cutting. The sizing is then washed out, and the uncut loops raised to their full height. The figures made by the uncut loops thus appear very slightly lower than the cut plush ground. The method is satisfactory, and a commercial success. The mechanical process which the complainant has sought to patent is the sizing of the uncut fabric for the purposes described.

It is old in many arts to size almost any fabric; old, also, to size a fabric upon both sides. Sizing is applied for all sorts of purposes,—to increase weight, as in cheap cotton goods; to stiffen the fabric, as in shirt bosoms; and so forth. In cut fabrics like plush or velveteen sizing has long been applied to hold the pile fast to the body of the fabric, so that the process of cutting shall not tear out or fray the pile, but shall leave its upper surface even. The functions claimed in argument by the patentee for his sizing are these: First. A fastening of the pile to the body of the fabric, so that the loops shall not be torn out in the cutting, but shall present an even-topped appearance after they are cut, as if they had been cut in the weaving, like ordinary plush. It was old in the art to apply sizing to the back of the fabric for this purpose; and in the Peterson patent it is stated that "it is well to size the fabric first carefully," without specifying if the face, or back, or both are intended. The patentee's use of sizing for this purpose shows no patentable novelty. The complainant's expert Livermore seems of the opinion that for this purpose there is no advantage in sizing the face of the fabric. Second. To fasten down to the body of the fabric the depressed uncut loops which are to form the pattern. Manifestly, sizing tends to glue the depressed loops to the body of the fabric, and to hold them down out of the way of the cutters while these are operating; otherwise the loops might rise in whole or in part during the cutting, and might thus be subjected more or less to the action of the rotary cutters. This function is stated in the Chwalla patent, especially at claim 5 and in Fig. 2, and in the Scott patent. It appears to be without patentable invention. Third. In defining more sharply the depressed figures. It is evident that this may be done by the stamping of sized pile as compared with unsized, if the sized pile is left soft enough to receive the desired impression, and at the same time is made so stiff as to retain the impression after that is received. If no sizing is employed, the impression can easily be made, but the resiliency of the fiber will cause the impression to lose its sharpness as soon as the embossing tool is removed, unless great heat is employed. On the other hand, if an embossing tool is pressed upon a sized material in a wet condition, manifestly the impression will not be so definitely retained as if it were stamped dry, because the moist walls of the depressed figure will tend to fall into the figure itself. This function of retaining a sharp impression may not be expressly stated in any of the prior patents, but it plainly exists therein. It is true that in the Scott patent the stamping is directed to be done while the sizing is wet, but the mere drying before stamping does not appear to constitute a patentable invention. Scott expressly provided for drying before cutting. To dry the size before embossing does not appear to me patentable, though this is claimed by complainant's expert Livermore. Fourth. The stiffening of the upright loops

against the action of the cutter. This is declared by the defendant's expert Browne, and by the complainant's expert Livermore, to be a hurt, rather than an advantage; and upon the whole I suppose this to be the case, though there is a little testimony to the contrary. Most of the apparent contradiction arises from confounding the necessary function of fastening the upright loops firmly in the body of the fabric, and the unnecessary function of stiffening the body of the loops against the cutting machine. Fifth. The greater ease of handling the sized fabric during the necessary operations. This is not claimed in the patent, though it is probably an important function. Doubtless, a patent protects a machine even when that machine is employed in a use not foreseen by the patentee; but where the process sought to be patented, as in this case, is an operation of the commonest sort, that common operation can hardly be made patentable by a useful result of the operation not claimed in the patent, or then known to the patentee. Moreover, the result would be equally effective in the patents of Chwalla, Scott, and Peterson.

It is urged by the complainant that the patent should be sustained by reason of the commercial success obtained by it. But this commercial success appears to me due in large part to the rotary cutter, which the patentee seems to have invented independently, though anticipated by Peterson. This was a more important improvement than the exceptionally abundant use of sizing. It is to be observed that the complainant's expert Livermore limits the "new steps" of the patent in suit to "the permeating the loops with size and thoroughly drying the size before embossing."

For these reasons, I think the invention was without patentable invention, and there must be a decree for the defendants. It thus becomes unnecessary to consider if Aveyard anticipated the manufacture of the complainant.

Bill dismissed, with costs.¹

Nathan Heard, for appellant.

Frederick P. Fish and W. Orison Underwood, for appellees.

Before COLT, Circuit Judge, and ALDRICH and BROWN, District Judges.

PER CURIAM. We agree with the reasoning and conclusion of the circuit court, and, in view of the prior patents referred to in its opinion, and of the common practice in the manufacture of embossed plush to dry the size before embossing, we are of the opinion that there was no patentable novelty in what the appellant terms the "characteristic" and "essential" steps in the Goodall process, namely, a thorough sizing of the fabric on the pile face and back, and the drying of the size before embossing. Moreover, the appellees have clearly proven that these exact steps were used by Aveyard, their superintendent, long prior to March, 1896, the date of Goodall's alleged invention. This evidence not only supports the view that these steps were merely an application of the common knowledge of those skilled in the art of embossing pile fabrics, but is, in our opinion, sufficient to clearly establish anticipation by Aveyard of what is said to be the essence of the Goodall invention and of the Goodall patent.

The decree of the circuit court is affirmed, and the costs of appeal are awarded to the appellees.

¹ NOTE. The patents referred to in the opinion are the British patent No. 8,547 of 1892, to Otto Petersen, and the French patent of the same year to the same inventor; the British patent No. 18,016 of 1897, to Gustav Chevalla; and the two British patents of 1883 to Dugald Scott, No. 5,902 and No. 5,904.

COATES et al. v. BOKER.

(Circuit Court of Appeals, Second Circuit. December 2, 1902.)

No. 62.

1. PATENTS—PATENTABLE NOVELTY—HAIR-CLIPPING MACHINE.

The Lee patent, No. 382,288, claim 4, for a hair-clipping machine having ball bearings between the reciprocating cutter-plates and the cap, in view of the common use of such bearings for the same purpose in analogous structures, is void for lack of patentable novelty.

Appeal from the Circuit Court of the United States for the Southern District of New York.

Appeal from a decree holding valid the fourth claim of letters patent No. 382,288, granted to Lewis S. Lee for a hair-clipping machine, and granting an injunction and an accounting. The opinion of the circuit court will be found in 115 Fed. 637.

Harold Binney, Louis C. Raeger, and S. L. Moody, for appellant.
Stewart Chaplin, for appellees.

Before LACOMBE, TOWNSEND, and COXE, Circuit Judges.

COXE, Circuit Judge. Every element of the combination of the fourth claim, except the ball bearings, was old at the date of Lee's application. The desirability of anti-friction devices in hair-clipping machines had long been recognized and rollers having this object in view had been interposed between the cap and the reciprocating cutter. Lee substituted balls for the rollers of the prior art.

In order to sustain the claim we must find that it involved an exercise of the inventive faculty to make this substitution. If ball bearings, which concededly are one of the most familiar means for overcoming friction, had been used by Lee for the first time in a clipping machine, it is possible that invention might be predicated of such use. But precisely what he did had been done before in an analogous art.

Several of the appellant's references are to grass and grain cutters, but such structures are entirely relevant to the present issue. Little attempt has been made in the testimony to dispute this proposition and one of the patents in proof is for a machine "for the cutting of hair, grass, and for other purposes." The application of an old structure to a similar use is not invention. *Briggs v. Ice Co.*, 8 C. C. A. 480, 60 Fed. 87. *Voss*, in March, 1888, had used ball bearings, in an almost identical environment, to reduce friction between the upper and lower cutting plates of a mowing machine. In view of this patent, which we regard a complete though not the only answer to the patent in suit, we feel constrained to hold the claim in controversy void for lack of patentability.

Decree reversed.

THOMPSON SCENIC RY. CO. v. CHESTNUT HILL CASINO CO.

(Circuit Court, E. D. Pennsylvania. December 16, 1902.)

No. 30.

1. PATENTS—ANTICIPATION—PLEASURE RAILWAYS.

The Thompson patent, No. 367,252, claim 5, for an elevated gravity and cable road, in combination with a car provided with an automatic grip, is void for anticipation.

2. SAME—INVENTION.

The Hinkle patent, No. 307,942, claim 1, for "a gravity tramway having a convoluted return curved track, crossing itself, substantially as described, for the purpose set forth," which is to economize space by making the track go twice around, instead of once, is void for lack of patentable invention; also *held* not infringed, even if valid.

In Equity. Suit for infringement of letters patent No. 307,942, for a gravity pleasure road, granted November 11, 1884, to Philip Hinkle, and No. 367,252, for an elevated gravity and cable railroad, granted to L. A. Thompson July 26, 1887. On final hearing.

George J. Harding, for complainants.

Joseph C. Fraley, for defendants.

ARCHBALD, District Judge.* The so-called Scenic Railway, constructed and operated by the defendants at Chestnut Hill Park, Philadelphia, violates, as it is claimed, two several patents held by the complainant company, one issued to Philip Hinkle, November 11, 1884, for a gravity pleasure road; and the other issued to L. A. Thompson, July 26, 1887, for an elevated gravity and cable road. The structure of which complaint is made consists of an elevated, undulating, part gravity and part cable, railway, covering an area about 600 feet long, and 25 feet wide in its central part, enlarged at one end to 35 feet, and at the other to about 70 feet. It is arranged in four tracks, two going and two returning in parallel lines, with loops at either end, the tracks of which are also parallel, except that, in order to make the whole a continuous or endless rail, the outer return track crosses the inner one overhead at the beginning of one of the loops, and becomes the inner outgoing track; the track so crossed veering to the outside, and becoming the outer outgoing one. This is illustrated in the following diagram:

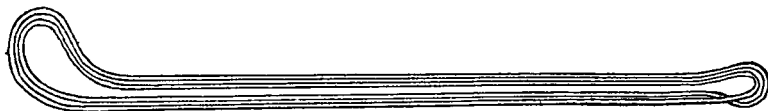

In one of the loops is an entrance pavilion, and at the other, a covered structure or tunnel; and, the road being designed for diversion and pleasure, a person desiring to enjoy it embarks on the cars at the pavilion, and is carried twice over the whole course, making a ride of about half a mile. In its elevation the road is made up of

* Specially assigned.

a number of sharply descending and ascending planes, the cars being carried down the one by gravity, and up the other by a cable; being caught by the latter as they pass from one to the other before their momentum has ceased, by means of an automatic grip, from which they are released in turn at the top of the next incline, where the force of gravity again engages them. In this way the cars are carried forward over the road, up one incline and down another, in a continuous course, imparting pleasure from their rapid and undulating motion. It is contended on the part of the plaintiffs that the defendants' structure infringes on the Hinkle patent, because the tracks are curved and convoluted, and that it adopts and infringes the Thompson patent, by reason of its being a part gravity and part cable railway, with a gripping device that acts automatically. The defendants deny the infringement, and attack the validity of the patents relied upon, and these are the questions to be disposed of.

All the claims of the Thompson Company have been withdrawn, except the fifth, which is for:

"An elevated gravity and cable railway in combination with a car, provided with a gripping device operating automatically, a cable and motive power arranged substantially as described, to elevate simultaneously cars traveling in opposite directions, substantially as and for the purposes set forth."

There can be no doubt that the defendant's railway comes within the terms of this claim. As both the exhibits and the description show, it is a combined gravity and cable railway; the cars which run upon it being equipped with a gripping device which operates automatically, and the motive power being so arranged as to elevate them simultaneously as they move back and forth in opposite directions from one end of the line to the other. It is of no moment that two cables are employed instead of one, or that the gripping device differs in some particulars from that described in the patent. It is the combination which is patented, and this, if valid, covers these variations, as equivalents. The infringement being clearly made out, this part of the case turns, therefore, on the validity of the patent.

The combination of ascending planes and descending inclines, over the one of which cars are elevated by means of a cable, and over the other are propelled by the force of gravity, is not new in general railroad engineering, or in this special branch of it. Over 50 years ago the Pennsylvania Coal Company constructed a coal-carrying road on this exact principle from its mines at Pittston, Pa., to Hawley, on the line of the Delaware & Hudson Canal, a distance of some 45 miles. This road was in successful operation for about 35 years, until supplanted some 17 years ago by a more pretentious locomotive railway. Even before this, the Delaware & Hudson Canal Company, which was engaged in the mining of anthracite coal in the Northern coal basin, had a similar road about 7 miles long from its coal mines at Archbald to Carbondale, and in 1858 extended the system some 16 miles further, over the Moosic Mountain, to Honesdale. This road was also in active operation until within 4 or 5 years. The well-known switch-back railway at Mauch

Chunk, Pa., affords another example. This, like the others mentioned, was originally a coal road extending some 9 miles to Summit Hill and return, but is now entirely given up to pleasure, and is still in operation. In each of these instances the railway was made up of sharply ascending planes, up which the cars were drawn by means of cables, alternating with slightly descending grades, called "levels," down which they were allowed to run by gravity, the location of the planes and levels being controlled by the physical conformation of the country traversed; and in each case there was a return track, made up in the same way, by which the cars were brought back to the starting point. These are matters of local history in the anthracite coal regions, so prominent and so well known to me by personal acquaintance and observation that I feel justified in referring to them in this way.

But to keep strictly to the record, there are several of the defendants' references which clearly disclose the elements under discussion. Thus the Graulhie British patent (1823), both in the specifications and drawings, shows an undulatory track composed of alternating ascending planes and descending inclines; the cars being drawn up the one by cables, and proceeding to the foot of the next plane on a descending grade by force of gravity; the device patented, of which this is a part, being claimed by the inventor to be applicable not only for the "conveyance of persons and goods over water and ravines for military or other objects," but also for "purposes of recreation and exercise." The Hinkle patent (1884), in suit, and the Lake British patent (1885), are also constructed on the same principle; the latter being, as it is to be noted, for improvements "in endless railways designed for recreation or amusement." Each of these establishes that a part gravity and part cable railway, with alternating ascending and descending grades, whether designed for business or pleasure, was not new at the time of the Thompson patent. As to these elements, therefore, the patent is without novelty; and the only question is how far it is saved by the combination with an automatic grip, which is also a part of the claim.

The designed effect of automatically engaging and releasing the car as it advances along the track is to produce a continuous, pleasurable motion, up and over the several undulations of the course from one end to the other, without stopping, and this is the combined result of the form of the track, the motive power employed, and the method of engaging it. It is therefore a true combination, and involving, as I think it does, the exercise of inventive skill, was properly patentable, provided it had not already been anticipated or disclosed in the art. But unfortunately for the complainants, it had been. It can be spelled out, as it seems to me, in the Graulhie (1823), already referred to; and it specifically and clearly appears in the Lake, of 1885. As we have already seen, this is for a combined gravity and cable road; and an automatic grip, working in combination the same way as in the Thompson, is also an essential feature. This is shown by the seventh claim, which is for:

"A circular railway track, having a general down grade, which operates the vehicle by gravity, and a uniform up grade, provided with a cable trac-

tion for the vehicle, both grades being so arranged in relation to each other that the momentum of the vehicle will carry it partly on to the up grade, and an automatically operating cable grip on the vehicle, all combined substantially as described."

Turning to the specifications, we find that the grip is to be "so arranged that a vehicle running up the incline * * * will automatically gripe the cable and be drawn up the incline by its help, and then be automatically released again when the top of the incline is reached." The same combination is to be found in the Hinkle (1884), in suit. The operation of the gravity pleasure road, which is there patented, is thus described:

"From this [starting] point an incline * * * reaches the highest * * * point of the track, and along the said incline * * * the cars are drawn by an endless cable * * * mounted on sheaves. * * * At certain points on the endless cable are loose ends or lengths * * *, the ends of which are provided with toggles or other desired fastening devices to engage * * * with the car or cars and draw them up the incline; and, as soon as the cars pass the highest point and pass onto the incline, * * * they run forward of the cable and release themselves from the fastening device, passing on around the track."

Nothing more is needed to show the entire anticipation by others of all that is covered by the Thompson patent. If any particular kind of gripping device was specified, it might, to that extent, perhaps, be saved; but, as it depends on the general combination of the elements brought together, it is of no novelty, and affords no ground for the present complaint.

The alleged infringement of the Hinkle patent remains to be considered. The first claim, which is the one relied upon, defines the patent as "a gravity tramway having a convoluted return curved track, crossing itself substantially as described, for the purpose set forth." The preceding specifications embrace considerably more than this, as we have just seen; but the patentee is, of course, confined to what he claims. The infringement asserted consists in the alleged curved and convoluted character of the defendants' tracks as they return upon each other at either end of the line. The object of the construction patented is declared, among other things, to be "to increase the distance of possible travel of the cars within the necessarily circumscribed space in which such structures are built"; and the invention is said to consist "of a continuous convoluted track, passing through two or more ellipses in traversing the space within which the track is contained." This is no more than saying that, in order to economize space and have a longer track, the railway is made to go twice around, instead of only once; one track at the end crossing the other at grade, or going over or under it. Surely this cannot be said to involve inventive genius. It is what any one of ordinary mechanical ability could do if the problem were presented, and is altogether too obvious to be patented. Without stopping to consider any references, I am persuaded that the patent is, to this extent, void, for want of invention.

But even if mistaken in this view, I am satisfied that the defendants have not infringed. Taking the description as it is given in the claim, it is not at all clear what is meant by a "convoluted return curved track crossing itself," and, standing alone, it is a question how far it

would be good. But the added words, "substantially as described for the purpose set forth," carry us back to the specifications; and we find there, as already stated, that this part of the invention consists of "a continuous convoluted track, passing through two or more ellipses." The inventor thus commits himself to an elliptical form of track, and the accompanying drawings and descriptions show that the ellipses are intended to approach very nearly to a circle, and to be closely concentric. The purpose of this is to permit of a central revolving observation platform or pavilion, which is an independent but important feature of the general invention. It cannot, therefore, be extended to embrace other forms of tracks, even though they double upon themselves so as to be in some respects curved and convoluted. In the defendant's railway, as already indicated, we have what might be called an elongated dumb-bell or golf stick. For 500 feet the tracks run in a straight line, parallel with each other, and just far enough apart to pass to and fro conveniently, the whole space occupied being about 24 feet wide; and while at the two ends they curve around together so as to return on themselves, and may, to that extent, be said to be curved and convoluted, yet, taken as a whole, they certainly do not have that form, nor any that is described or covered by the patent. Both on the ground, therefore, of the noninfringement of the Hinkle patent, as well as the invalidity of it, this part of the plaintiffs' case cannot be sustained, any more than the other.

Let a decree be drawn dismissing the bill, with costs.

BISHOP & BABCOCK CO. v. LEVINE.

(Circuit Court, S. D. New York. November 29, 1902.)

1. **PATENTS—CONTRIBUTORY INFRINGEMENT—SALE OF UNCOMPLETED ARTICLE.**
One who makes and sells a part of a structure, adapted and intended to be completed by the purchaser, and which when so completed is an infringement of that of a patent, is a contributory infringer, although the uncompleted article as it leaves his hands lacks essential elements of the patented device, and in itself is not an infringement, where, unless so completed, it is not operative and has no commercial value.
2. **SAME—LIQUOR CABINET.**
The Berner patent, No. 537,434, for a combination cabinet for liquids on draught, claims 1 and 2 construed, and defendant held chargeable with contributory infringement in making and selling the shell of a cabinet adapted to be completed by the insertion and connection of pipes and faucets, and which, on such completion, is substantially the structure of the patent.

In Equity. Suit for infringement of letters patent No. 537,434, for a combination cabinet for liquids on draught, granted April 16, 1895, to H. D. Berner. On final hearing on pleadings and proofs.

Herbert A. Banning, for complainant.
J. L. V. Heinberg, for defendant.

¶ 1. Contributory infringement of patents, see notes to Edison Electric Light Co. v. Peninsular Light, Power & Heat Co., 43 C. C. A. 485.

LACOMBE, Circuit Judge. The specification states that the apparatus is "adapted to be used for drawing mineral waters or liquors of any kind which are under a sufficient pressure to flow through the pipe from beneath upward through the several chambers to the faucets." The pipe (or several pipes, each for a different liquid) passes from the source of supply into a lower cooling chamber, where it coils under ice; thence it passes, at the back, through a cold-air passage, open to upper and lower chamber, into the upper chamber, where it again coils under ice and terminates in faucets at the front of the upper chamber. The cover of the lower chamber is sectional, the front half consisting of a removable drip pan adapted to receive and convey away the drippings from and through a perforated sheet cover serving as a receptacle for cups or glasses, and the rear half is a corrugated or fluted sheet metal top which extends over the front section sufficiently to convey the drippings into the drip pan. Either or both the sections may be removed to fill the lower chamber with ice, or for any other purpose. These parts, as the specification states, "might be modified and yet remain within the spirit of the invention." The claims relied on are:

"1. The cabinet described having the lower chamber and the cover therefor consisting of the drip pan H, and perforated plate K over the same, and the separate removable cover section L along its back portion having the drain plate overlapping the said drip pan, and the upper chamber having the faucets above the said drip pan H, substantially as set forth.

"2. The cabinet described having the chambers A and E and the back portion C connecting said chambers, a series of faucets arranged along the front portion of the chamber E, the drip plate K and associated parts over the front portion of the chamber A, and the cover L having a drainer surface overlapping the said plate K, substantially as set forth."

The past history of the controversy greatly simplifies the issues now to be determined. In November, 1898, suit was brought on the patent against the present defendant, in which, upon his written consent, a decree was entered adjudging the validity of the patent, and that an apparatus which the defendant then made was an infringement. That decree has never been set aside, and the only question now to be determined is whether some modifications which defendant has since made take his apparatus out of the claim of the patent. The manner in which the apparatus is set up for use is as follows: A manufacturer constructs the two cooling chambers, upper and lower, with the connecting cool-air passage, with suitable apparatus for the entrance of pipes and for their exit at the places where the faucets are to be attached, and with drip pan, perforated cover, and corrugated sectional top arranged appropriately to the location where the faucets are to be placed. Defendant's expert appropriately described this as a "shell"; until the pipes are inserted and the faucets affixed it has no commercial utility. It is then turned over to a purchaser, or, as defendant says, "to the plumbers who connect the pipes in the boxes [chambers]." Such a "shell" was held to be an infringement in the first suit.

The only differences which, as defendant himself testified, are to be found in his later apparatus are these: (1) The drip pan is made to slide under the corrugated plate, or rear sectional cover of the

lower box. It is, nevertheless, removable. The sliding may be an improvement, but the drip pan is still within the patent. (2) The drain pipe from the upper chamber connects with the superstructure of the lower chamber, then with the trough from which it enters the waste pipe. But the drain pipe is not an element in either the first or second claim. (3) The corrugated drain plate on the lower box slants or pitches toward the back. In the patent it pitches towards the front; in the former infringing device it was level. The variance seems to be immaterial. (4) The upper ice box or chamber is made removable. This is for the purpose of making it more readily adjustable to the surroundings amid which it is to be placed. When put up, it becomes as stationary as the upper chamber of the patent. Defendant's expert calls these minor differences, as indeed they are. They effect no change of function, and in no wise alter the combination of the first two claims, which are the only ones relied on. The same expert bases his opinion that defendant's structure does not infringe on the absence of pipes and faucets. He says:

"As there are neither pipe coils for cooling liquids by the application of ice thereto, nor faucets to draw the liquids in dispensing the same, I do not find that the defendant's cabinet or structure contains the invention designed to be secured by the patent. * * * It is a mere shell, so to speak, without the means of serving as an apparatus for dispensing liquors on draught. And therefore it is without the ability to perform the offices necessary in a beverage dispensing apparatus."

This proposition is undoubtedly sound. As it leaves defendant's hands, the cabinet is not the completed structure of the patent. It is made and sold, however, adapted to receive pipes and faucets so as to become an operative apparatus; its parts are so arranged that when these are inserted it will be such a structure as the patent described and claims; without this adaptability it could not be sold at all, for it would have no commercial utility. That the defendant knows this, and that he makes and sells his "shell" with the intention that it shall be thus fitted with pipes and faucets, seem entirely clear. He is a contributory infringer under all the authorities, and complainant may take the usual decree.

WESTINGHOUSE ELECTRIC & MFG. CO. v. ORANGE COUNTY GAS & ELECTRIC CO.

(Circuit Court, S. D. New York. November 17, 1902.)

1 PATENTS—INFRINGEMENT—ELECTRICAL CONVERTERS.

The Stanley patent, No. 469,809, for a system of electrical distribution, covers a combination of which one element is a converter, in which the length of wire in the primary coil is that determined by the so-called "Stanley rule," and is not infringed by a converter in which the length of such wire is substantially different from what it would have been had that rule been applied and followed.

In Equity. Suit for infringement of letters patent No. 469,809, granted to William Stanley March 1, 1892, for a system of electrical distribution. On motion for preliminary injunction.

J. Edgar Bull, for the motion.

M. B. Philip, Charles E. Mitchell, and H. B. Brownell, opposed.

LACOMBE, Circuit Judge. The questions arising upon this motion were considered in the opinion of the circuit court of appeals in this circuit in *Westinghouse Electric & Mfg. Co. v. Saranac Lake Electric Light Co.*, 113 Fed. 884, 51 C. C. A. 514. Without now going exhaustively into the discussion with which the briefs are concerned, it will be sufficient succinctly to indicate the reasons for the conclusion now arrived at in the case at bar. The circuit court of appeals opinion states that the claims in controversy cover a combination which includes primary and secondary coils, and in which the primary coil is given "such length of wire exposed to magneto-electric induction that, when operated by the dynamo with which it is used, under certain conditions certain results will follow." The opinion proceeds:

"The man skilled in the art would not have found in that art anything which would have told him precisely what that length of wire should be. The claim does not give any formula for determining what it should be, and, if the specification were equally silent, there might be some question as to whether Stanley had really contributed anything of importance to the art; certainly it would yet remain for others to inform the art just how to find out a length which would operate as indicated in the claim. But when the patentee in his claim enumerates as one element of his combination a wire of a length which will accomplish the result sought to be achieved, and his patent discloses a method for determining that length with mathematical exactness, his claim may fairly be sustained for the length thus shown, although it might be that some other length covered by the language of the claim, but not of the rule, would fall outside the claim."

It seems to this court that the court of appeals found that the claims of the patent were for a combination of the elements therein set forth, of which one element was a primary coil having a length of wire equal to what would be found to produce the indicated results when applying the Stanley rule; and that the claims were sustained for a combination of the enumerated elements into a converter, not merely for a process of determining one of those elements. In the case before the court of appeals the length of wire in the primary coil of the infringing device, when operated by the dynamo with which it was to be used with its secondary circuit open, produced the result indicated in the claim. It did not appear by satisfactory evidence that the length of the wire in the primary coil was substantially different from the length which would have been indicated if the maker had employed the Stanley rule in determining such length. The single reference on the motion for reargument was not at all persuasive, possibly because the witness took a different view of the patent from that subsequently settled on by the court. Therefore it was held that the transformer then before the court infringed, the court of appeals concurring in the opinion of the circuit court that "the order in which the steps necessary to produce the desired transformer are taken would seem to be immaterial." The court of appeals was fully advised that in the case before it there was no proof that the person who made the transformer actually used the so-called "Stanley rule" in determining the length of wire in the primary coil, but it did appear that the length used was substantially the length he would have determined if he had used

that rule, its action under prescribed conditions was identical, and infringement was found. The evidence in the case at bar as to the two new types of transformer "A O" and "G" is much more specific as to the length of wire in primary coil; and, in view of the repeated and concurrent testimony of the many experts called by the defendant, it cannot be held that the length of wire in primary coil is substantially the same as it would be if such length were determined by the Stanley rule. If it be not substantially the same, we seem to have the very exception suggested in the opinion of the court of appeals,—“some other length covered by the language of the claim, but not of the rule,”—and infringement is not shown.

The motion is denied.

UNION SPECIAL SEWING MACH. CO. v. AMERICAN RAVELLER CO. et al.

(Circuit Court, S. D. New York. December 29, 1902.)

1. PATENTS—INVENTION—TRIMMING ATTACHMENT FOR SEWING MACHINES.

The Clark & Murphy patent, No. 324,818, for an improvement on the trimming attachment for sewing machines shown in the Dewees patent, No. 266,783, is void for lack of patentable invention, being an obvious mechanical improvement for bringing the cutting parts into closer contact as they become worn.

In Equity. Suit for infringement of letters patent No. 324,818, for an improved trimming attachment for sewing machines, granted August 25, 1885, to William S. Clark and John F. Murphy. On final hearing.

C. L. Sturtevant and Joseph C. Fraley, for complainant.
John R. Bennett, for defendants.

COXE, Circuit Judge. This is an equity action for the infringement of letters patent, No. 324,818, granted to William S. Clark and John F. Murphy, August 25, 1885, for an improvement upon the trimming attachment patented to J. W. Dewees October 31, 1882, No. 266,783. The Dewees trimmer, unlike those of the prior art, did not cut the fabric which was being trimmed, but accomplished the desired result by means of two blunt-edged toggle jaws, which rocked on each other, and thus pinched off the superfluous fabric. These toggle levers were adjusted to rock in close contact and when in operation were subjected to great pressure, which, in time, wore away the jaws and prevented true contact from being maintained. Dewees provided against this lost motion by making the lower jaw vertically adjustable so that it could be moved up in close contact with the upper jaw. The only serious objection to this arrangement was that in time the jaws were raised above the plane of the work plate. That Dewees contemplated the adjustment of the upper jaw also, should it be deemed necessary, is quite deducible from the following statement in his specification:

“To provide for adjusting edges of the levers or jaws g h toward each other, to take up wear or lost motion, the construction shown in the drawing may be employed.”

Clark and Murphy adopted this suggestion and made the upper jaw also adjustable. The specification says:

"The nature of our improvement consists in the combination of the plate or bracket with a cross-plate that is dovetailed on the upper end of the bracket-plate, the upper jaw being attached to said cross-plate, whereby the upper jaw may be adjusted toward the lower jaw in order to take up the wear thereof, and means for clamping the cross-plate to the bracket-plate, as will be more fully set forth hereinafter. * * * The object of our invention is to make the jaws last much longer than they have heretofore, and this we accomplish by means of the devices, whereby we are enabled to adjust the upper jaw also, as previously fully described, and herein shown. It will be seen that the cross-plate, to which the upper jaw is attached, can be adjusted on the bracket-plate for a considerable distance, (nearly half an inch,) and thereby the life of the jaws can be very considerably increased. Another advantage gained by our improved devices is that we are enabled to keep the meeting edges of the jaws always in line with the upper side of the cloth-plate of the sewing machine, which cannot be accomplished when only the lower jaw is adjustable."

The patent contains 5 claims, and four of them are involved, but it will only be necessary to refer to the first, which fully covers the improvement. It is as follows:

"(1) In a trimming attachment for sewing machines, the combination of the bracket-plate, the cross-plate adjustable vertically on the bracket-plate, the lower toggle jaw fulcrumed to the bracket-plate and vertically adjustable, and the upper toggle jaw fulcrumed to the cross-plate, whereby the meeting edges of the jaws may be maintained in line with the cloth-plate of the sewing machine as the jaws wear away, substantially as described."

The only defense argued is the lack of invention. It will be seen that the difficulty in the Dewees mechanism was the ordinary one which occurs when two parts which must be maintained in close contact are worn down by use. The obvious thing to do in such cases is to move the parts so that they will again come together. Dewees had already shown how to do this, but, as the necessity for the downward movement of the upper jaw had not then been demonstrated he showed the movable adjustment only in connection with the lower jaw. As the complainant's counsel correctly state:

"It is true that the earlier Dewees patent No. 266,783 disclosed a means for vertically adjusting the lower jaw for taking up wear, but this adjustment was not sufficient and it was found necessary to adjust the upper jaw."

When it became apparent that the constant raising of the lower jaw above the throat plate prevented the machine from accomplishing the best results, what more natural than the adoption of the obvious expedient of lowering the upper jaw to meet the lower jaw at the proper plane? The necessity for this would occur spontaneously to the skilled workman, and, having once grasped the idea, the means were ready at his hand. Dewees had shown how the adjustment could be made and the mechanic had only to duplicate in the upper jaw the adjusting mechanism of the lower jaw with such obvious mechanical changes occasioned by the new environment as would occur to any skilled machinist. Of course it was necessary to make a compact and firm adjustment with the parts strong enough to withstand the enormous pressure on the levers, but to do this did not call into play anything beyond ordinary skill, especially when the

patent to Gilbert shows adjustable upper and lower knives in trimming attachments for sewing machines.

The court finds it impossible to predicate invention of the natural and almost obvious changes made in the Dewees trimmer by the patentees. Where parts that must be in close contact are worn down by friction there is but one thing to do, namely, move them into close contact again. If the point of contact must be always on a fixed plane it is manifest that both parts must be moved so that their action will be neither above nor below that plane. The patentees saw what any skilled mechanic must have seen and they did what any skilled mechanic must have done. No new result was accomplished. The Dewees attachment operated after the upper jaw had become vertically adjustable precisely as it did before, and the right to use it with one or both jaws adjustable became the property of the public when the Dewees patent expired. *Industrial Mfg. Co. v. Wilcox & Gibbs Sewing Mach. Co.*, 50 C. C. A. 387, 112 Fed. 535.

The bill is dismissed.

UNION SPECIAL SEWING MACH. CO. v. AMERICAN RAVELLER CO. et al.

(Circuit Court, S. D. New York. December 29, 1902.)

1. PATENTS—INVENTION—TRIMMER FOR SEWING MACHINES.

The Dewees patent, No. 309,699, for a trimming attachment for sewing machines, construed, and held valid as showing patentable invention.

In Equity. Suit for infringement of letters patent No. 309,699, for a trimming attachment for sewing machines, granted December 23, 1884, to J. W. Dewees. On final hearing.

C. L. Sturtevant and Joseph C. Fraley, for complainant.
John R. Bennett, for defendants.

COXE, Circuit Judge. This is an equity action founded on letters patent, No. 309,699, granted to J. W. Dewees, December 23, 1884, for a trimming attachment for sewing machines; being an improvement upon the device shown in a previous patent to Dewees, No. 266,783, dated October 31, 1882. The trimmer of the prior patent did not operate satisfactorily when thick heavy goods were being trimmed. Such fabrics would pucker in front of the toggle jaws causing them to sever, or cut the cloth in a curved irregular line. The object of the invention in suit was to provide an attachment which would feed the material, whether thick or thin, regularly and in a straight line. This is accomplished by providing the movable jaws of a trimming attachment with serrations, whereby the jaws will operate to feed forward and sever the material. The serrations, or teeth, take hold of the cloth, on the downward motion of the upper jaw, and feed it forward simultaneously with the severing action. They also prevent the cloth from turning under the jaw thereby preserving it and severing it in a straight line. The claim is as follows:

"What I claim as my invention is as follows: In a fabric-trimming device, the combination, with a movable severing device, blunt upon its periphery and

provided with teeth upon its edges, of a similarly blunt-edged device adapted to work against the other, substantially as described."

The patent expired *pendente lite*. At the argument the complainant's title was admitted, the defense of prior use was withdrawn and infringement was conceded. The only defense argued was the lack of patentability. The device in question is a simple but ingenious improvement upon a meritorious and popular sewing machine attachment. The earlier structure would not operate successfully on heavy and thick knit fabrics used for undershirts and drawers. The difficulties encountered in this respect were remedied in the device of the patent by the simple expedient of placing a series of teeth on the side edges of one of the blunt toggle jaws, leaving them, in all other respects, to operate as before. The prior art shows teeth on the top of feeding devices, but such structures would not avail in the Dewees attachment where the blunt jaws, having smooth and not serrated faces, rock together and pinch off, rather than cut off, the fabric. The distinguishing feature of the invention was the arrangement of the notches on the vertical edge rather than on the face of the cutter. This feature was new with Dewees, nothing like it is found in the prior art and it accomplished the desired result. By its use the Dewees attachment was for the first time made to operate successfully on thick fabrics. It is thought that to do this required an exercise of the inventive faculties. The skilled artisan would have proceeded along different lines. The idea which, in all probability, would have first occurred to him would be to roughen the face of the lower jaw or cut notches therein, but he would soon have discovered that if this were done the value of the jaw as an abraising and severing device would be destroyed. He would then have sought a solution by attaching to the device some of the rotary or reciprocating feeding mechanisms of the prior art, and, finding this a complicated and expensive, if not an impossible, task to accomplish he would have given up the problem as insolvable. The step taken by Dewees was by no means obvious; it was, on the contrary, ingenious and unusual and produced an unexpected result. Even now it is difficult to explain why notches on the side edge of the severing jaw will operate to feed thick and heavy material to the cutters with such uniformity and precision. The improvement made the trimming attachment of the earlier patent applicable to an entirely new industry; it went immediately into use and was acquiesced in by all until the defendants began infringing about a year before the patent expired. The contrivance of the patent, simple though it be, was a valuable contribution to the knitting art and, even if there were doubt on the subject of patentability, it is peculiarly a case where the doubt should be resolved in favor of the inventor.

The complainant is entitled to a decree for an accounting.

SHERBOURNE et al. v. WILLCOX & GIBBS SEWING MACH. CO.

(Circuit Court, E. D. Pennsylvania. December 10, 1902.)

No. 95.

1. PATENTS—ACTION FOR ROYALTIES—DEFENSE OF ADJUDGED INVALIDITY OF PATENT.

It must clearly and certainly appear from the opinion of the circuit court of appeals in an infringement suit that the court held the patent void, before such decision can be availed of, as matter of law, to defeat an action to recover royalties from a licensee under such patent.

At Law. On motion by defendant for judgment non obstante veredicto on question of law reserved.

See 105 Fed. 970.

Frank P. Prichard and John G. Johnson, for plaintiffs.

P. K. Erdman, Hubert Howson, and George Tucker Bispham, for defendant.

DALLAS, Circuit Judge. Upon the trial of this case the court directed a verdict for plaintiffs, reserving the question of law whether the decision of the circuit court of appeals for the Third circuit in the case of Industrial Mfg. Co. v. Wilcox & Gibbs Sewing Mach. Co., (No. 4, September term, 1901) 112 Fed. 535, relieves the defendant, under the evidence in this case, from liability, etc. The point primarily presented by this reservation is whether the circuit court of appeals did or did not decide, in the case referred to, that a certain patent (No. 341,790, division B) was invalid, for, if it did not so decide, a fundamental essential of the defense interposed to this action is nonexistent. That case was an appeal from a decree by which the patent above mentioned had been sustained and its infringement found, and the determination of the appellate court was that that decree "must be reversed and the record remitted, with instructions to dismiss the complainant's bill." It is obvious that this determination might have been based upon the ground either that the patent was invalid, or that it had not been infringed, or upon both of these grounds; and, but for the first sentence of its final paragraph, the opinion which accompanied the order of reversal would perhaps support the defendant's insistence that the patent was held to be void. But that sentence is, "If the patent No. 341,790 [division B] can be sustained, it must be upon a construction so narrow that the defendant's device does not infringe;" and it is not easy, especially in view of the general disinclination of the courts to unnecessarily overthrow patents, to reconcile this final statement with the supposition that by what had previously been said it was intended to decide that upon no construction of it could the patent in question be upheld. I, however, think that I should, if possible, abstain from putting a construction upon an adjudication of the court

¶1. Effect of previous adjudications as to patents on circuit court of appeals, see notes to Thomson-Houston Electric Co. v. Hoosick Ry. Co., 3 C. C. A. 565; National Cash Register Co. v. American Cash Register Co., 27 C. C. A. 427; Emigration Co. v. Gallegos, 32 C. C. A. 475.

of appeals in which I participated; and in this instance it is not requisite that I should do so. The present case will no doubt be taken to that court, and to it, I think, may properly be left the interpretation of its own decision. It is enough now to say that it does not appear with certainty that it was intended to have the effect which the defendant ascribes to it, and for this reason the question reserved must be resolved in favor of the plaintiffs. *Russell v. Place*, 94 U. S. 606, 24 L. Ed. 214.

The defendant's motion for judgment non obstante veredicto is denied, and judgment will be entered for the plaintiffs upon the verdict in the sum of \$6,957.96.

101
210 **BURGER v. LUCAS.**

(Circuit Court, S. D. New York. November 24, 1902.)

1. PATENTS—INFRINGEMENT—PAPER DECORATIONS.

The Burger patent, No. 603,619, for a paper decoration, construed, and held not infringed, on motion for a preliminary injunction.

In Equity. Suit for infringement of letters ^U patent No. 603,619, for a paper decoration, granted to Rudolf ^U Burger May 10, 1898. On motion for preliminary injunction.

Herman Lindheimer, for the motion
James C. Chapin, opposed.

LACOMBE, Circuit Judge. The validity of the patent is not disputed, the only question being whether or not the device which defendant makes infringes the device of the claim. The point of difference on which defendant relies is that his sheets of tissue paper are pasted together only at edge positions, none of them being pasted in the center, whereas each of the five claims of the patent mentions a pasting in the center. In the absence of any testimony as to the prior state of the art, it would seem that this center pasting is an essential of the patent. Nowhere in the specification is any other method referred to than that of pasting one layer in the corners, and the next in the center. The language of some of the claims is not entirely clear, but, on the record as it now stands, it is doubtful whether they should be so construed as to cover decorations where there is no pasting at the center, but only alternately at opposite corners. They can be fairly and reasonably construed so as to cover only the device mentioned in the specification. To illustrate: The first claim uses the language, "layers * * * pasted on each other, once in the center, and once at the edge, or near the edge, or at edge positions." This may fairly mean alternately in the center and either (1) at the edge (i. e., the whole edge, a continuous line of contact), or (2) near the edge, also a continuous line, or (3) at separate and scattered points on the edge. The use of the plural in the phrase "at edge positions" does not necessarily import a pasting alternately at one edge position, and then at an opposite one.

The motion for preliminary injunction is denied.

DE SOLA et al. v. POMARES et al.

AMSINCK et al. v. SAME.

(District Court, S. D. New York. December 5, 1902.)

1. SHIPPING—RECOVERY OF PREPAID FREIGHT NOT EARNED—CUSTOM.

The settled rule of commercial law that freight prepaid, but which is not earned by the delivery of the goods, is to be refunded, in the absence of special agreement to the contrary, where the loss is not due to any fault of the shipper, cannot be overcome by proof of a local custom that freight prepaid is not to be returned in case the vessel is lost on the voyage.

2. SAME—CONTRACT MADE BY BILLS OF LADING—VARIANCE BY PAROL.

Bills of lading in the ordinary form, which show prepayment of the freight, in connection with the established rules of law, constitute a completed contract, binding the carrier to refund the freight, if not earned; and, in the absence of fraud or mistake, parol evidence is not admissible to change the conditions of such contract.

In Admiralty. Actions to recover freight prepaid, but not earned.
Black & Kneeland and Carter & Ledyard, for libellants.
Owen & Sturges, for respondents.

ADAMS, District Judge. These are actions brought to recover back certain freights, amounting respectively to \$1,478.35 and \$2,739.68, which were prepaid on goods to be transported by the respondents as charterers of the bark Canopus, from New York to La Libertad and Acajutla, Salvador and San Jose, Guatemala. The goods were duly delivered to the vessel and bills of lading taken therefor from the master.

The charter party provided for a trip from New York to Corinto, Nicaragua and/or Amapolo, Honduras and/or La Libertad and/or Acajutla and/or San Jose, Guatemala and/or Champerico, Guatemala and/or Ocos, Guatemala and return to New York by way of Punta Arenas, Costa Rica, for which the master of the vessel was to receive £2,100, £525 thereof to be advanced in New York, £525 thereof to be paid on the right delivery of outward cargo on the West coast and the balance of £1,050 on the right delivery of the homeward cargo at the port of discharge. A portion of the outward cargo which was destined for Corinto was duly delivered there and the freight of \$1,039.80 earned. Just after leaving that port the vessel was lost and no further freight was earned. The freight that was collected in advance and not earned remained in the possession of the respondents.

It is well settled that freight being the compensation for the carriage of goods, if paid in advance, is, in all cases, unless there is a special agreement to the contrary, to be refunded, if from any cause not attributable to the shipper the goods are not carried (The Kimball, 3 Wall. 37, 45, 46, 18 L. Ed. 50) and the respondents here, recognizing the principle, have alleged that the libellants tendered the cargo in question and the respondents agreed to receive it on

condition that the freight should be paid in advance and should in no event be returned to the shipper because of any failure on the vessel's part to perform the voyage in whole or in part, and they have further alleged that according to a well known custom in the port of New York freight prepaid is in no event to be returned in case of the loss of the vessel upon the voyage, which custom was well known to the libellants.

With respect to the custom, testimony was taken out of court, tending to show that in dealing with the respondents, who were the principal, if not the only, merchants engaged in furnishing transportation between New York and the ports in question, the witnesses understood that prepaid freight was not recoverable back and they therefore insured it, but the testimony was taken subject to objection as to its competency and materiality and evidently is not admissible to establish the general custom pleaded, nor would the custom, if proved, operate to overcome such a well settled rule of commercial law as the one in question—*Emery v. Dunbar*, 1 Daly, 408; *Frith v. Barker*, 2 Johns. 327.

The other question is whether a special agreement was made between the parties to the effect that the prepaid freight was not to be refunded in any event. There is no contention that there was any written evidence of the shipping contract apart from the bills of lading, and they do not contain anything relating to such an agreement. They were stamped by the respondents with the words: "Freight paid in New York," which apparently amount to nothing more than a statement showing the payment in advance, which would bring into operation the rule with respect to such freights being repayable if the consideration of carriage should fail. There is no evidence to show that the words by usage in the particular trade to which the contract referred had any different meaning from what they would ordinarily import. It is contended, however, that there was a specific oral understanding between the parties, prior to the delivery of the goods, that a rule made by the respondents that they would not receive goods otherwise than upon freight being paid in advance and not to be returned in any event, should apply to these shipments. Testimony was taken out of court, over proper objection, for the purpose of establishing such an understanding, but there is no competent evidence of the fact. Bills of lading, like other written contracts, are not, in the absence of fraud or mistake, neither of which is suggested in this case, open to change in their conditions by parol—*The Delaware*, 14 Wall. 579, 602, 603, 20 L. Ed. 779—This is not a case where something in the minds of the parties was left unexpressed and with respect to which the contract is silent. It is in itself a complete instrument, which in connection with a firmly established rule of law, requires the repayment of the freight paid in advance and not earned. It is not permissible therefore to consider parol testimony which might serve to entirely change the nature of the contract in such particular—*Godkin v. Monahan*, 27 C. C. A. 410, 83 Fed. 116; *Association v. Edwards*, 51 C. C. A. 279, 113 Fed. 445.

Decrees for the libellants.

THE SEABOARD.

(District Court, S. D. New York. December 3, 1902.)

1. SHIPPING—LOSS OF CARGO—LIEN.

The fact that a steamer was being operated under a charter, even if known to shippers, does not relieve her from a lien arising from default in her obligation to the cargo.

2. SAME—STIPULATIONS IN BILLS OF LADING—NEGLIGENCE.

Stipulations in bills of lading that the carrier shall not be liable for any damage to goods which is capable of being covered by insurance will not relieve the vessel from liability for loss due to the carrier's negligence.

3. SAME—HARTER ACT.

Loss of cargo, resulting from the overloading of a lighter, due to the negligence of officers of the ship, is within section 1 of the Harter act [U. S. Comp. St. 1901, p. 2946], and not within section 3, and cannot be relieved against by a stipulation in the bills of lading.

4. SAME—LIEN FOR LOSS OF CARGO—DEFENSE OF LACHES.

A purchaser of a vessel cannot invoke the defense of laches to defeat a suit by an insurer to enforce a lien for the negligent loss of cargo, occurring before the purchase, where the suit was commenced within a year after the loss, and it does not appear that he bought without knowledge of the lien.

In Admiralty. Suit in rem for loss of cargo.

Coudert Bros., for libellant.

Robinson, Biddle & Ward, for claimant.

ADAMS, District Judge. This was an action brought by the libellant, by rights of subrogation, to recover certain amounts paid by it to various shippers of goods on the steamer Seaboard for delivery at Carrabelle, Florida, in September, 1899.

The principal facts have been agreed upon and may be stated briefly as follows:

The steamer, prior to and during September, 1899, was being run by one W. C. Taylor, as charterer under the name of the Mobile Steamship Company, as a common carrier of such freight as she might, from time to time, receive for transportation between Mobile and Carrabelle and other points; that upon each trip from Mobile, the steamer was put upon the berth as a general ship, and advertised as such, and received such cargo as was offered her, giving receipts in a form which, among other things, provided that "The carrier is not to be liable for any damage to any goods which is capable of being covered by insurance" and that the agent of the vessel should have "the option of hiring lighters at the port of destination for the landing of the * * * goods, at the expense and risk of the owners of the said goods"; that about the middle of September, 1899, or a little later, the steamer Seaboard was placed upon berth for cargo in Mobile, and the goods in question were shipped upon her to certain consignees, in good order and condition, to be transported to Carrabelle and there delivered to the respective consignees, or to a connecting carrier, to be forwarded to the consignees; that the Walker Steamship Company owned the steamer in May, 1899, and continued to own it until May 25, 1900, during which time she was

chartered to said Taylor, who had the right, and exercised it, of appointing all her officers and crew except the chief engineer; that upon the 25th of May, 1900, the owner sold the steamer to the present claimant; that the several shippers had heard that some of the steamers being operated by Taylor, under the style of the Mobile Steamship Company, were chartered vessels but did not know whether the Seaboard was under charter, or not; that each of the shippers insured with the libellant the respective goods shipped by them, in amounts which were fair values of the goods with ten per cent. added, and the several lots of goods were fairly worth at Carrabelle, the several amounts for which they were insured, plus the freight thereon less the added ten per cent.; that the steamer transported the goods safely to Carrabelle and there unloaded them into a lighter and the lighter sank before it reached the wharf, resulting in a loss of the goods, upon which no freight was paid; that the libellant paid to the several shippers the amounts for which the said goods were so insured; that the steamer could not reach a wharf at Carrabelle on arrival there owing to the shoalness of the water and had to unload into lighters in order that the goods might be landed, which was customary at that port with steamers of the Seaboard's draft; that the lighters upon which the goods were loaded were procured for that purpose by the agent of the said Taylor at Carrabelle; that after the loss of the goods the steamer was operated between Mobile and Tampa, Florida, until May 25, 1900, when she left for New York and in being so operated, she was in Mobile six times during 1899 and nine times in 1900, up to April 16th.

The only substantial controversy upon the facts arose with respect to the seaworthiness of the lighter and some testimony was taken in that connection but I do not think it needs discussion because it clearly appears that the lighter became unseaworthy through being negligently overloaded by the officers and crew of the steamer and it was from such cause that the loss occurred. Two lighters were used for the purpose of delivering the cargo, and the one in question sank alongside of the ship a few minutes after the loading was finished.

Various defenses have been put forward by the claimant to escape liability: (1) the fact of the vessel being chartered and the shippers being put upon inquiry with respect to the provisions of the charter; (2) the effect of the insurance in connection with the provision in the bill of lading relating thereto; (3) the effect of the Harter Act, and (4) laches.

(1) The fact of the steamer being operated under a charter, even if the fact were known to the shippers, would not serve to relieve the steamer from a lien arising from default in her obligation to the cargo—*Freeman v. Buckingham*, 18 How. 182, 15 L. Ed. 341; *The Alert*, 9 C. C. A. 390, 61 Fed. 113.

(2) The stipulation with respect to insurance will not excuse loss by the carrier's negligence. *The Hadji*, (C. C.) 20 Fed. 875; *The Egypt*, (D. C.) 25 Fed. 320.

(3) This loss is within section 1 of the Harter Act [U. S. Comp. St. 1901, p. 2946] and not within section 3. The primary cause of the loss was negligence in the delivery of the cargo, for which no exemp-

tion can be had by stipulations in the bills of lading—*Knott v. Botany Worsted Mills*, 179 U. S. 69, 21 Sup. Ct. 30, 45 L. Ed. 90; *The Germanic*, (D. C.) 107 Fed. 294.

(4) It does not appear that the claimant purchased the vessel without knowledge of the liens and it is not therefore in a position to invoke the doctrine of laches. Moreover, the delay between the time of the accident, September, 1899, and the filing of the libel, July 28, 1900, was not so unreasonable as to affect the libellant's rights in view of the circumstances of the case.

Decree for libellant, with interest. An order of reference may be entered, if the amount of loss is disputed.

AMMON-STIVERS MIN. CO. v. GREAT NORTHERN MINING & DEVELOPMENT CO.

(Circuit Court, S. D. New York. October 10, 1902.)

1. EQUITY JURISDICTION—SUFFICIENCY OF BILL.

A bill *held*, as against a demurrer, to state a cause of action in equity to charge defendant as trustee with respect to mining property, on the ground that the person from whom defendant acquired title obtained the same while acting as receiver of the property and in violation of his duty to complainant, to conserve whose interests as owner he was appointed.

In Equity. On demurrer to amended bill.

Rollin C. Wooster, L. J. Morrison, and Peter C. DeWolf, for complainant.

Shearman & Sterling and John A. Garver, for defendant.

TOWNSEND, Circuit Judge. The complainant alleges that on June 25, 1895, it was the owner and in full possession of certain mining claims and real estate in Montana; that the work required by law upon the mining claims was thereafter performed and the requisite affidavits duly filed; that thereafter, in 1895, judgment in foreclosure upon mechanics' liens which had accrued while another corporation was in possession, but not the owner, was rendered, and the right and title of the complainant to the value of part of the property was sold under execution under said judgment, and that, although the purchasers acquired no rights by virtue of said sale, they took possession; that on or about June 15, 1896, complainant's president went to Montana, and was endeavoring to raise money to meet the demands of said intruders, when one L. G. Phelps represented to him that if it would employ W. W. Phelps, brother of said L. G. Phelps, as complainant's attorney in an action which had been commenced to recover the possession of said property, and would consent that said L. G. Phelps should be appointed receiver, he would furnish money to meet the demands of said intruders and to protect the property and secure to complainant possession thereof; that said proposal was accepted and carried into effect, so far as the change of attorneys and the appointment of the receiver,

and that a suit was commenced by said W. W. Phelps for the complainant; that said L. G. Phelps qualified as receiver; that said suit was not pressed; that thereafter, in 1896, said L. G. Phelps bought the title to the property, individually, upon sheriff's sale, for \$219.61 on a judgment for \$209.30, of which complainant had no notice, in a suit in which legal service had not been made; that, the entry of judgment in said suit being regular upon its face, under the laws of Montana the court which has rendered the judgment is without jurisdiction to set it aside as against the defendant herein, defendant having acquired its title since said suit; that, while said L. G. Phelps was receiver, he further endeavored to cloud the title of complainant in the property by employing one Littlejohn to relocate a former mining claim upon it, although there was no legal ground for a relocation; that thereafter a firm claiming to have made some arrangement with alleged lienors of said property were allowed by said Phelps while receiver to assume possession thereof, and that in 1897 a receiver was appointed in an action brought against said firm, and that said L. G. Phelps arranged to purchase said property from said firm and obtain all its rights for a consideration not exceeding \$15,000, and that thereupon the last-mentioned receiver was discharged, and that the complainant had no knowledge of the said acts and doings of L. G. Phelps until some time in the year 1900; that said L. G. Phelps on March 15, 1897, caused a petition signed by him, and representing that there was no further occasion for his receivership, and an order discharging him as receiver, both dated October 24, 1896, to be filed in the court in which he was appointed, which petition falsely stated that the dangers which necessitated his former receivership had ceased to exist, whereas, in fact, they had increased; that complainant had no knowledge of said order discharging said L. G. Phelps as receiver until the year 1901; that, previous to the application for said order discharging said L. G. Phelps as receiver, he had acquired in his individual name the title to most of complainant's property, and that shortly after the entry of said order he openly took title thereto in his own name; that he shortly after commenced to operate said property, and realized more than \$75,000 from said operation; that in the summer of 1897 he made arrangements with the incorporators of the defendant to convey to them the property; that about August 1, 1898, defendant was incorporated, and that thereafter said L. G. Phelps conveyed or caused to be conveyed all of said property belonging to complainant to said defendant; that on or about March, 1899, defendant began to operate the mines and extract ore therefrom, and since that time has taken from the mines gold bullion in excess of \$1,500,000, and that the value of the ore in one mining claim is \$6,000,000, and the value of another mining claim in said property is at least \$2,000,000; that defendant and its incorporators and officers had notice of the equitable title of complainant by reason of the facts aforesaid; that said L. G. Phelps is without the jurisdiction of the United States.

Defendant insists that the allegation of title in the defendant is an allegation of matter of law, and that the facts whereby defend-

ant acquired title should be fully and sufficiently stated; that on the face of the complaint complainant has title and an adequate remedy at law by suit in ejectment; that no facts justifying the interposition of a court of equity exist; and that the complainant has not sufficiently excused his delay in bringing this action.

While it seems very doubtful whether complainant upon the hearing will be able to establish sufficient facts to fix upon the defendant the character of a trustee of the complainant, and very probable that it may be estopped by delay in asserting its rights during the time the property was being developed and its value proved, yet, upon the allegations, the acts of said Phelps, in acting for his own individual interest against the parties whose interest as receiver he was bound to protect, were contrary to his official duty, and the proceedings of himself and his brother as an attorney as alleged were contrary to the duty which they owed to the complainant.

The demurrer is overruled, and the defendant required to answer. The question of laches, as well as all the other questions involved, can better be decided when the facts are fully proved on final hearing.

In re LIPSET et al.

(District Court, S. D. New York. December 5, 1902.)

1. **BANKRUPTCY—HEARING BEFORE REFEREE—EXCLUDED TESTIMONY—RECORD.**
Under General Orders in Bankruptcy No. 37 (32 C. C. A. xxxvi, 89 Fed. xiv), providing that in proceedings in equity instituted for the purpose of carrying into effect the provisions of the act, or for enforcing the rights or remedies given by it, the equity rules of the supreme court of the United States shall be followed as nearly as may be, it is the duty of a referee in bankruptcy to take down all excluded testimony, and make the same a part of the record, with his ruling on the objections, and also the exceptions which may be taken notice of in connection with such testimony.

In Bankruptcy. The following is the opinion of Referee WISE:

I, Morris S. Wise, one of the referees of said Court in Bankruptcy, and to whom had been referred the issues arising on specifications filed in opposition to the application for the discharge of the bankrupts herein, do hereby certify that in the course of the proceedings in said cause before me, the following question arose pertinent to said proceedings:

The counsel for opposing creditors having a witness under examination propounded a question as follows:

"Q. Did Mr. Levittan at any time refer you to Mr. Milch or introduce Mr. Milch to you as his representative in the transactions?"

Counsel for the bankrupts objected to the question as immaterial, incompetent, irrelevant and leading. Such objection was sustained and an exception noted in favor of the opposing creditors. The witness was then directed to answer the question, the same to be taken subject to the objection and exception.

Counsel for the bankrupts then interposed the following objection: "I object to the witness being compelled to answer after my objection is sustained, and I ask you to certify to the district judge the question whether, notwithstanding an objection is sustained by the referee, it is proper practice to compel the witness to answer and to incorporate such answer in the records."

And the said question is certified to the judge for his opinion thereon.

I have held that the said question should properly be answered in the affirmative and that the proper practice is notwithstanding that an objection

is sustained, to have the question objected to answered, and the answer incorporated in the records for the following reasons:

The question certified to the honorable district judge is a very simple one and yet it is of considerable importance in view of the fact that no express decision has been made upon the point involved in this district.

General Orders in Bankruptcy No. 37 (32 C. C. A. xxxvi, 89 Fed. xiv), provides as follows:

"In proceedings in equity instituted for the purpose of carrying into effect the provisions of the act or for enforcing the rights or remedies given by it, the rules of equity practice established by the Supreme Court of the United States shall be followed as nearly as may be. * * *"

The rule in equity applicable to the taking of depositions is Rule 67 as amended, and that rule was passed upon by the United States Supreme Court in the well known case of *Blease v. Garlington*, 92 U. S. 1, 23 L. Ed. 521. See, also, *Ridings v. Johnson*, 128 U. S. 212, 9 Sup. Ct. 72, 32 L. Ed. 401. And the reason for having the record include evidence which would otherwise be excluded was well considered in the able opinion of Circuit Judge Lacombe in *Appleton v. Ecaubert*, (C. C.) 45 Fed. 282. And that learned judge pointed out that if the appellant tribunal should reach the conclusion that the court erred in excluding evidence, it would have to remand the case for the taking of additional proof in respect to the suppressed deposition.

That the practice pursued herein is the proper one has also the authority of the text writers.

Foster's excellent work on Federal Practice, volume 1, (2d Ed.) page 506, states the rule for the proper taking of evidence as follows:

"The examiner must note all objections and exceptions to questions and answers and take the testimony subject to them, but can not decide on their validity." *Loveland, Bankr. 502*, has the following: "It would, therefore seem that referees have power to pass upon the competency, relevancy or materiality of any question in the course of an examination subject to have the question reviewed by the judge upon certificate. The more convenient practice would seem to be for the referee to make his rulings and thereupon require the question to be answered. If his ruling be against the question and the court should reverse his finding, it would not be necessary to have a re-examination of the witness. If the court should affirm such ruling, the answer may properly be disregarded."

And in the opinion of *Brandenburg*, the author of another excellent text book on the present bankrupt law, it was held:

"The same rule would doubtless apply under this act as under a similar provision of the act of 1867, where it was held that the register had no power to decide on the competency, materiality or relevancy of any question, and therefore had no power to exclude any question." Citing *In re Rosenfield*, 1 N. B. R. 60, Fed. Cas. No. 12,059; *In re Bond*, 3 N. B. R. 2, Fed. Cas. No. 1,618; *Brandenburg, Bankr. p. 420*.

The same rule was laid down by the honorable district judge for the Southern District of California, who in a very long and well considered opinion, decided that "a hearing before a referee under the bankrupt act of 1898 is in the nature of a hearing in equity and is governed by the rules in equity practice of the Federal Courts both as to the hearing itself and as to the review by the judge, and that it is the duty of the referee, although he must pass on objections to testimony, to cause all testimony excluded to be taken down and made a part of the record, with the rulings and exceptions noted; and upon a review, the judge is not required to reverse the decision because of the erroneous admission or exclusion of evidence, but it becomes his duty to determine the issues de novo upon the competent evidence in the record, or he may recommit the case for further hearing as the circumstances may require." *In re De Gottardi (D. C.) 114 Fed. 328*.

This practice naturally, may lead at times to some abuses on the part of parties who may desire to obstruct or unduly prolong examinations, but it was expressly provided by General Orders No. 22 (32 C. C. A. xxv, 89 Fed. x) that the court "shall have power to deal with the costs of incompetent, immaterial or irrelevant depositions or parts of them as may be just," which is substantially an incorporation of a similar provision found in the sixty-

seventh rule of the practice in equity as amended of the United States Supreme Court.

The referee will of course, also be in a position to protect witnesses in the exercise of their constitutional privilege, and for any abuse of the power of unduly expanding an examination the court will speedily find a remedy therefor by the imposing of the full costs and expenses occasioned by such undue exercise of the power of examination.

An additional reason why in this particular instance the ruling of the referee was correct may be found in the fact that the referee in this case, sitting as special commissioner on the hearing of testimony offered in support of the specifications filed in opposition to the discharge of the bankrupts, is acting not in the capacity of referee in bankruptcy, but in the advisory capacity, such as a special master in chancery or as a standing examiner of the court (*Fellows v. Freudenthal*, 4 Am. Bankr. R. 490, 42 C. C. A. 607, 102 Fed. 731).

And such officials in the taking of testimony, under the equity practice of the United States courts, invariably take all answers given by witnesses to all questions asked of them.

Joseph H. Harris, for bankrupts.
Rudolph Marks, for objecting creditors.

ADAMS, District Judge. The witness should answer and the answers be incorporated in the minutes.

The referee's opinion correctly states the law in the matter.

WONG HIM v. CALLAHAN et al.

(Circuit Court, N. D. California. December 5, 1902.)

No. 13,245.

1. SCHOOLS—CHINESE—SEPARATE SCHOOLS—CONSTITUTIONAL RIGHTS.

Pol. Code Cal. § 1662, provides that, where separate schools have been established by the school trustees for children of Mongolian descent, such children must not be admitted into any other schools. *Held* that, regardless of the motive in the enactment of the statute, where the Chinese schools offered the same advantages as the other schools, the operation of the law was not a violation of Const. U. S. Amend. 14.

2. DECREE—DEFAULT—COMPLAINT—INSUFFICIENT ALLEGATIONS.

Though a defendant may be in default, the complainant is not entitled to a decree pro confesso where the allegations of his complaint are insufficient to support a decree in his favor.

George D. Collins, for complainant.

DE HAVEN, District Judge. The question presented to the court for decision at this time arises upon complainant's motion for a decree pro confesso under equity rule 18. The complainant is an infant, and native-born citizen of the United States, of Chinese parentage, and seeks in this action, brought by his father as prochein ami, for a decree against the principal of the Clement Grammar School in the city and county of San Francisco and the members of the board of education of that city and county, restraining them from preventing the admission of the complainant into the Clement Grammar School as a pupil. The bill alleges that all children, irrespective of age and

¶ 2. See Equity, vol. 19, Cent. Dig. § 958.

nationality, are permitted to attend said grammar school, with the exception of children of Chinese descent, and that the defendants exclude the complainant from the right to attend this school upon the sole ground that he is of Chinese descent, and claim the right to do so under the provisions of section 1662 of the Political Code of the state of California, which gives to the trustees of school districts the power to establish separate schools for children of Mongolian or Chinese descent, and further provides that "when such separate schools are established, Chinese or Mongolian children must not be admitted into any other schools." It is further alleged that this statute is in conflict with the fourteenth amendment to the constitution of the United States, in that it deprives the complainant of the equal protection of the laws of California relative to his right to admission as a pupil into the public schools of the state. As I construe the allegations of the bill, there has been established in the city and county of San Francisco a separate school exclusively for Chinese children and children of Chinese descent, which the complainant can attend. It is not alleged that such school does not afford the same advantages in the matter of acquiring an education as is given to children of schools to which Chinese are not admitted. The sole ground of complaint is that the maintenance of separate schools for children of Chinese descent is a discrimination against such children, and it is alleged that such discrimination "is arbitrary, and the result of hatred for the Chinese race." The validity of the statute referred to does not depend upon the motive which may in fact have actuated the members of the legislature in voting for its enactment. Upon such an inquiry the courts have no right to enter. If the law does not conflict with some constitutional limitation of the powers of the state legislature, it cannot be declared invalid. Concerning the authority of the state over matters pertaining to public schools within its limits, and the validity of legislation of the character of that under consideration, it is well settled that the state has the right to provide separate schools for the children of different races, and such action is not forbidden by the fourteenth amendment to the constitution, provided the schools so established make no discrimination in the educational facilities which they afford. When the schools are conducted under the same general rules, and the course of study is the same in one school as in the other, it cannot be said that pupils in either are deprived of the equal protection of the law in the matter of receiving an education. *Ward v. Flood*, 48 Cal. 36, 17 Am. Rep. 405; *Lehew v. Brummell* (Mo.) 15 S. W. 765, 11 L. R. A. 828, 23 Am. St. Rep. 895; *State v. McCann*, 21 Ohio St. 198; *People v. Gallagher*, 93 N. Y. 438, 45 Am. Rep. 232; *People v. School Board of Borough of Queens*, 161 N. Y. 598, 56 N. E. 81, 48 L. R. A. 113; *U. S. v. Buntin* (C. C.) 10 Fed. 736; *Bertonneau v. Board*, 3 Woods, 177, Fed. Cas. No. 1,361. The case of *Roberts v. City of Boston*, 5 Cush. 198, may also be cited in support of the conclusion that the matters alleged in the bill do not show that complainant has been deprived of the equal protection of the laws of the state of California relating to education.

2. The defendants are in default, but this does not entitle the complainant to a decree pro confesso, unless the allegations of the bill are

sufficient to support a decree in his favor. *Thomson v. Wooster*, 114 U. S. 104, 5 Sup. Ct. 788, 29 L. Ed. 105. The bill does not, in my opinion, state facts sufficient to entitle the complainant to the relief prayed for, nor to any relief, and for this reason must be dismissed, and it is accordingly so ordered.

**KWONG CHIN CHONG v. UNITED STATES. YUET SING v. SAME.
WING WO OHONG v. SAME.**

(Circuit Court, S. D. New York. November 11, 1902.)

Nos. 550, 551, 552.

1. CUSTOMS DUTIES—CHINESE SPIRITUOUS BEVERAGES.

Chinese spirituous beverages imported in bottles containing on the average one-tenth of one gallon, and in spirituous strength below proof, are dutiable at \$2 per gallon, under paragraph 311 of the tariff act of 1883.

2. SAME—BOTTLES CONTAINING BEVERAGES.

Bottles containing Chinese spirituous beverages assessable under paragraph 311 of the tariff act of 1883 are themselves subject to duty of three cents each, under paragraph 310, which provides that bottles containing spirituous liquors shall pay the said rate unless otherwise specially provided for.

Albert Comstock, for the importers.
D. F. Lloyd, Asst. U. S. Atty.

TOWNSEND, Circuit Judge. These cases involve several sorts of Chinese spirituous beverages imported under the tariff act of 1883. Some of them were classified at \$2 per gallon, under paragraph 311 of that act. This classification is not now contended by the importers to have been wrong. Such of the items on the invoices, however, as were described under the name "medicine wine," or similarly, and were returned for duty at 50 cents per pound, under paragraph 118, are now contended to have been not wines and not medicinal, but to have been dutiable at \$2 per gallon only, under paragraph 311 of said act.

These three cases were decided by the board very early in its history, —in 1891,—without a hearing of the importers, and upon evidence which, by stipulation, is now before this court. The board of general appraisers at a later date than that at which these cases were decided took up some further protests on the same issue, and therein reached the above-stated conclusion contended for by the importers, and embodied it in its decision G. A. 2,098, which was accepted without appeal by the treasury department, and has since been applied by the board to numerous similar protests. In accordance with this evidence and these proceedings it must be held that the items above designated were dutiable under paragraph 311, as claimed, and to that extent only the decision of the board is reversed.

It should be added, as testified to before the board of appraisers in the later cases and incorporated in its finding, that the items in question were imported in bottles containing on the average one-tenth of

one gallon, and that in spirituous strength the beverage was below proof. In connection with the assessment under paragraph 118, on the contents, the glass bottles containing it were assessed with duty at 30 per cent. ad valorem, under paragraph 133 of the act of 1883. In view of the conclusion, however, that the contents of these bottles should have paid duty under paragraph 311, it follows that the bottles containing it should pay duty at the rate of three cents each, under paragraph 310, which provides that bottles containing spirituous liquors shall pay the said rate of duty unless otherwise specially provided for.

In all other respects than as thus specified the decision of the board is affirmed.

UNITED STATES v. PERKINS et al.

(Circuit Court, S. D. New York. November 11, 1902.)

No. 3,213.

1. CUSTOMS DUTIES—OFFER TO ENTER—EFFECT.

Where goods were tendered for consumption entry before 4 o'clock on July 24, 1897, and on refusal of the tender a warehouse entry was made on the 26th, they were dutiable under the tariff act of 1894, and not the act of 1897 [U. S. Comp. St. 1901, p. 1626].

Appeal by the United States from a Decision of the Board of United States General Appraisers.

Henry C. Platt, Asst. U. S. Atty.
Albert Comstock, for importers.

TOWNSEND, District Judge. On July 24, 1897, before 4 o'clock in the afternoon, certain goods arrived on the steamship *Latouraine*, consigned to the appellees herein. They tendered a consumption entry of the goods before 4 o'clock p. m., but such tender was refused by the collector, and on the following Monday, July 26, 1897, they made a warehouse entry of the goods. The question raised is the same as that raised in the case of *U. S. v. Legg*, 45 C. C. A. 134, 105 Fed. 930, namely, whether the goods are dutiable under the tariff act of 1894 or of 1897 [U. S. Comp. St. 1901, p. 1626]. The only distinction between that case and the case at bar is that in the *Legg* Case the importer renewed his tender of the consumption entry on July 26th, while in this case, in order to avoid the payment of extra duty, the appellees made a warehouse entry of the goods on the 26th. In *U. S. v. Legg* it was held that whatever rights the importer had prior to 4 o'clock on July 24, 1897, vested at that time. It does not appear herein that the importers waived such rights by presentation of a warehouse entry and bond.

I think this case clearly falls within the reasoning in the *Legg* Case, and the decision of the board of appraisers is therefore affirmed.

FEDERAL MANUFACTURING & PRINTING CO. v. INTERNATIONAL BANK NOTE CO.

(Circuit Court, S. D. New York. October 7, 1902.)

1. EQUITY PLEADING—INTERROGATORIES.

The fact that interrogatories filed with a bill are not specifically referred to therein, in conformity to equity rule 43, does not excuse defendant from answering the same, where he is not prejudiced by the informality.

2. SAME—DISCOVERY—TRADE SECRETS.

A defendant cannot be required to answer an interrogatory requiring it to state how an article manufactured by it is constructed if not constructed as charged in the bill, where it states that such construction is a trade secret.

·In Equity. On exceptions to answer.

Willis Fowler and William J. Gibson, for complainant.

Philipp, Sawyer, Rice & Kennedy, for defendant.

TOWNSEND, Circuit Judge. Complainant excepts to the answer because it fails to reply to nine interrogatories filed by the complainant. Defendant insists that the interrogatories are not referred to in the bill, and that the bill, therefore, does not conform to the requirements of rule 43 of the equity rules. It does not appear that the defendant is prejudiced by this informality, and the interrogatories may, therefore, be considered as part of the bill. Defendant makes no objection to the first eight interrogatories, other than as above stated. The ninth interrogatory is as follows: "(9) If said automatic wipers for plate printing presses were not so constructed, how were the same constructed?" Defendant objects to this interrogatory on the ground that it is not a proper one, and, further, on the ground that defendant is entitled to preserve the secrets of its manufacture, and that in defendant's special business such preservation of its secrets is peculiarly important. Complainant cites *Coop v. Development Inst. (C. C.) 47 Fed. 899, 901*; *Id.*, 48 Fed. 239. This case involves a construction of a walking track of a gymnasium. Inasmuch as such tracks must be known to the general public, and the construction is easy of ascertainment, no such objection could have been raised in that case. In *Gamewell Fire Alarm Tel. Co. v. City of New York (C. C.) 31 Fed. 312*, also cited by complainant, the opinion does not specifically pass upon this question, and the interrogatory, as claimed by the complainant, differs substantially from the ninth interrogatory herein. In any event, defendant should not be required to answer this interrogatory, provided such answer would disclose trade secrets, and, as such is claimed to be the fact, it should be so stated. No costs will be taxed.

THE SANTO DOMINGO.

(District Court, E. D. New York. December 18, 1903.)

1. WAR—PRIZES—DESTRUCTION TO PREVENT RECAPTURE.

A captured vessel is not appropriated "for the use of the government," within the meaning of Rev. St. §§ 4615, 4624, 4625 [U. S. Comp. St. 1901, pp. 3127, 3130], so as to entitle the captors to prize money where they destroy it to prevent recapture.

2. SAME—ORDER OF NAVY DEPARTMENT.

Order 492 of the navy department providing for four alternatives: (1) Sending the prize to the nearest home port, (2) converting it to public use in case of need; (3) selling it if it may not be sent in for reasons indicated; (4) destroying it if it cannot be sold or there be imminent danger of recapture,—does not authorize destruction of the prize with the view of converting it to public use.

3. SAME—BOUNTY.

Where captors of a vessel destroy it to prevent recapture, they are not entitled to prize money, but to bounty, under Rev. St. § 4635, providing that there shall be paid as bounty to the captors of a vessel of war which is immediately destroyed for the public interest, but not in consequence of injuries received in action, \$50 for every person who shall be on board at the time of such capture.

Harriman & Fessenden (James D. Fessenden, of counsel), for captors.

George H. Pettit, U. S. Atty.

THOMAS, District Judge. The United States war ship *Eagle* pursued the *Santo Domingo*, a Spanish armed vessel of equal or superior force, and, between 3 and 4 o'clock in the afternoon of July 12, 1898, captured her after she had been stranded upon the coast of Cuba. The *Eagle* could have floated her prize only with assistance and after a delay of several days. The commander, believing that there was imminent danger of recapture, directed that the prize be destroyed by fire, and at sundown of the same day this was done. However, \$1,100, the value of certain property taken from her, has been deposited for disposition in this action. This money, less the proper expenses of the action, should be distributed to the captors.

But the captors contend that the vessel and her cargo of food and munitions of war, intended for the enemy, were appropriated "for the use of the government" of the United States, within the meaning of Rev. St. §§ 4615, 4624, 4625 [U. S. Comp. St. 1901, pp. 3127, 3130], and that they should recover the value thereof. Their argument is: The vessel was captured; there was imminent danger of recapture; hence the commander of the *Eagle* directed the destruction of the prize; such destruction was equivalent to an appropriation for the use of and by the United States, acting through its representative, the commander of the *Eagle*; hence the captors stand in the same position as if the prize, or her proceeds, if sold, had been taken to the proper port and adjudicated, or as if she had been taken in fact and used by the United States.

This contention is not approved. Captors share in such property as is delivered for adjudication. Such delivery must be actual, unless on account of the condition of the property it cannot be made, when

sale is authorized by the commanding officer present, or unless it has been appropriated "for the use of the government." Rev. St. § 4615 [U. S. Comp. St. 1901, p. 3127].

"Sec. 4625. If by reason of the condition of the captured property, or if because the whole has been appropriated to the use of the United States, no part of it has been or can be sent in for adjudication, or if the property has been entirely lost or destroyed, proceedings for adjudication may be commenced in any district the secretary of the navy may designate; and in any such case the proceeds of anything sold, or the value of anything taken or appropriated for the use of the United States, shall be deposited with the assistant treasurer in or nearest to that district, subject to the order of the court in the cause. If, when no property can be sent in for adjudication, the secretary of the navy shall not, within three months after any capture, designate a district for the institution of proceedings, the captors may institute proceedings for adjudication in any district. And if in any case of capture no proceedings for adjudication are commenced within a reasonable time, any parties claiming the captured property may, in any district court as a court of prize, move for a monition to show cause why such proceedings shall not be commenced, or institute an original suit in such court for restitution, and the monition issued in either case shall be served on the attorney of the United States for the district, and on the secretary of the navy, as well as on such other persons as the court shall order to be notified." [Page 3130.]

It should be observed that there is no provision for a deposit in case of property "lost or destroyed"; nor are the captors specifically enabled to institute proceedings in any district, "if the property has been entirely lost or destroyed," although provision is made in the first sentence of the section for an adjudication under such conditions. The captors may institute proceedings after three months, in any district, if the secretary of the navy has not designated one, "when no property can be sent in for adjudication," by reason of its condition requiring sale, or because it has been appropriated by the United States. This limitation of the captors to initiating proceedings in any district of their selection to the conditions last mentioned, and thereby excluding them from instituting proceedings in such district "when the property has been entirely lost or destroyed," indicates that congress did not contemplate that the captors could have any interest in property destroyed. The last sentence of the section refers to suit for restitution and proceedings for adjudication by "parties claiming the captured property."

Section 4624 [page 3130] provides:

"Whenever any captured vessel, arms, munitions, or other material are taken for the use of the United States before it comes into the custody of the prize court, it shall be surveyed, appraised, and inventoried, by persons as competent and impartial as can be obtained, and the survey, appraisal, and inventory shall be sent to the court in which proceedings are to be had; and if taken afterward, sufficient notice shall first be given to enable the court to have the property appraised for the protection of the rights of the claimants and captors. In all cases of prize-property taken for or appropriated to the use of the government, the department for whose use it is taken or appropriated shall deposit the value thereof with the assistant treasurer of the United States nearest to the place of the session of the court, subject to the order of the court in the cause."

The statute provides for bringing into port for adjudication the property itself, or the proceeds of the property, if it has been sold, unless before delivery it shall have been appropriated upon an ascertainment of its value in the manner stated.

This brings the discussion to an essential duty imposed upon captors as a prerequisite of recovering prize money. A captor is not entitled to prize money unless he capture and prevent recapture. The captor must take and deliver. He must in offensive action seize, and, if need be, in defensive action retain, and his success in both regards, if it be good prize, perfects his right to an adjudication for prize money. Rescue or recapture defeats such right. But the captors' present claim is that they may capture, and that, if there be imminent danger of recapture, which event would preclude prize money, they may destroy the res, and recover as in case of due delivery; that is, while defense against recapture is a condition precedent to recovery, they urge that they may avoid such defense, and its consequences to them, by destroying the thing itself, and recover as if they had successfully defended it. Their apprehended inability to fulfill the condition precedent, viz., prevent recapture, is their very excuse for its nonperformance, and the basis of their claim for an award only due upon such performance. They neither took in the prize nor attempted to do so; they neither defended nor attempted to defend; they destroyed the prize in anticipation of their incapacity to do these things; yet they seek the benefit that matures only upon such accomplishment. When captors take a lawful prize, they have alternative duties,—to save it, if practicable, to destroy it, if it be impracticable to save. The first duty insures prize money, other elements of the right existing; the second duty involves the sacrifice of prize money, and the pecuniary reward is in the form of bounty. But captors cannot scuttle the ship captured, and have her in the form of prize money. Their money reward is measured by what they deliver secure from the enemy. If persons be sent to capture a vessel, and thereupon to destroy her, the destruction precludes prize money (*Decatur v. U. S.*, Dev. Ct. Cl. p. 201), and if the destruction ex necessitate rei must and does follow capture the captor's status is the same. Indeed, if it is impracticable to bring the property into port or to make some safe disposition of it, the captor's duty is to destroy, although it result in a renunciation of prize money. The usual duty to save a capture from the enemy to earn prize money stands as does the duty to sacrifice the prize and prize money if occasion demands. The suggestion that a person bound to save against the peril of recapture, if he would have prize money, may avoid the peril by destroying the subject of defense, and yet recover a compensation measured by the value or proceeds of the thing destroyed, as if it had been defended and saved, involves contradictions which forbid its adoption as a rule of law.

But it is urged that the navy department authorized appropriation of a captured vessel by the destruction thereof, if there was imminent danger of recapture, leaving to the judgment of the commander present whether the vessel should be taken for its value by the government. The directions found in certain subdivisions of general order No. 492 are as follows:

"(20) Prizes should be sent in for adjudication, unless otherwise directed, to the nearest home port, in which a prize court may be sitting.

"(21) The prize should be delivered to the court as nearly as possible in the condition in which she was at the time of seizure. * * *

"(24) The title to property seized as prize changes only by the decision rendered by the prize court. But, if the vessel itself, or its cargo, is needed for immediate public use, it may be converted to such use, a careful inventory and appraisal being made by impartial persons and certified to the prize court.

"(25) If there are controlling reasons why vessels may not be sent in for adjudication, as unseaworthiness, the existence of infectious disease, or the lack of a prize crew, they may be appraised and sold; and if this cannot be done they may be destroyed. The imminent danger of recapture would justify destruction, if there was no doubt that the vessel was good prize."

This order is intended to interpret the statutes for the guidance of captors. It provides for four alternatives: (1) Sending the prize to the nearest home port; (2) converting it to public use in the case of need; (3) selling it if it may not be sent in for reasons indicated; (4) destroying it if it cannot be sold or there be imminent danger of recapture. One of these courses the captor must adopt. It is quite obvious that the navy department did not intend to authorize the destruction of the prize with the view of converting it to public use. The order for converting to use, numbered and stated separately from the order respecting destruction, excludes conversion to public use by way of destruction. Destruction is authorized only in case the prize cannot be sent in for adjudication, converted to the use of the government, or sold, upon some of which events the recovery of prize money depends. The order adds nothing to the usual practice or duty of captors, nor does it attempt to create new rights or a new method of meeting the requirements of the statutes.

It has been pointed out already that the statute upon which award depends fixes the condition of receiving it, and that the salving of property captured, and not its destruction, is a prerequisite of sharing in the proceeds thereof. Indeed, compensation, measured by the value or proceeds of something saved, is the very vital thought of the statute. Conservation, not destruction, entitles.

It is not to be inferred that the navy department intended to give to its order a meaning inconsistent with the usual law and the statutes. The language itself explicitly excludes such interpretation, and is in perfect harmony with the recognized duty to take and keep, or to destroy, if necessary, to prevent recapture, or in case of inability to bring into port.

In view of such conformity of the general order to the usual duty of the commander of the capturing force, the long-prevailing practice in such cases, and the law as heretofore interpreted, it is not to be presumed that the department intended to commit the government to the payment of the value of all prizes destroyed, at the instance of every victorious captain, where there was imminent danger of recapture, or where it was necessary to abandon them without sale, upon the theory that such destruction is equivalent to an appropriation to the use of the government. If the government appropriates when it destroys in apprehension of recapture, it may appropriate when destruction is prompted by any other motive, and destruction in every case would become appropriation to its use. The statute does not permit the distribution of the proceeds of nonexisting property that was never sold, or of the amount of the value of property that was appropriated to use by being made incapable of use. If

a once res not in esse may be regarded as useful—that is, profitable—to the government, because its negativity renders it incapable of use by the enemy, yet in no proper sense can it be said that a thing destroyed to prevent use by the hostile force, and thereby actually bereft of entity, is appropriated to the use of the government. The use of nothing as if it were something baffles conception. No. 24 of the order of the navy department directs that “if the vessel itself, or its cargo, is needed for immediate public use, it may be converted to such use.” The captors’ contention would paraphrase the order as follows: “‘If the vessel * * * is needed for immediate public use, it may be converted to such use’ by destroying it.” Use is service. Property may be devoted to a service that will result in its consumption or destruction, but destroying it for the sake of destruction, to prevent anybody using it, is not user.

While refined definition is not desirable, it is inferred that the statute uses words according to their usual meaning, and that it does not contemplate that the use of the vessel appropriated should consist in the act of laying waste to it, or in annihilating it, or the benefit arising therefrom; and the general order of the navy department certainly excludes any intention to take and pay for the property when no use thereof is actually had, and it is destroyed before such actual use for the purpose of preventing its recapture.

The compensation of the captors in the present case seems to fall under section 4635, which provides, among other things:

“* * * And there shall be paid as bounty to the captors of any vessel of war captured from an enemy, which they may be instructed to destroy, or which is immediately destroyed for the public interest, but not in consequence of injuries received in action, fifty dollars for every person who shall be on board at the time of such capture.”

The scheme of the statute seems to be to allow captors in case of proper prize to share in the value of property saved, and to reward by way of bounty for property destroyed in the engagement, or in consequence of injuries sustained in action, or destroyed thereafter for the public interest. The following is a summary of the holding herein:

The destruction of a lawful prize at the instance of the commander of the captors, by reason of the imminent danger of recapture, is not such an appropriation of the property for the use of the government as constrains the United States to deposit the value thereof for distribution, and entitles the captors to share therein. This conclusion is based upon the following findings:

(1) The statute contemplates that the captured property, or the proceeds, if sold, shall be brought to the proper port, unless it be destroyed or appropriated to the use of the government before such delivery, and, in case of appropriation before or after delivery, the value of the property shall be deposited by the government for disposition. Adjudication as to the legality of the capture and award of prize money in a proper case are required when the vessel is brought in, sold, or appropriated, but adjudication only as to lawful prize as distinguished from award of bounty money when the property has been destroyed.

(2) The general order of the navy department clearly distinguishes between conversion to public use and destruction, and makes one the alternative of the other.

(3) The duty of saving the property from recapture is a condition precedent of recovering prize money, which is measured by what is delivered secure from the hostile force, and not by what may be destroyed in view of the peril of recapture or other exigency, and this duty to defend and to save cannot be used as a plea to escape defense, under the guise of appropriation at the public expense.

(4) The common duty of captors is to destroy, if the property cannot be brought in, sold, or safely kept, and such destruction precludes the recovery of prize money. The performance of this long-existing obligation is inconsistent with and has not and cannot be regarded as an appropriation for the use of the government.

(5) Property annihilated, although its nonexistence be beneficial in depriving the enemy of its use, is alike incapable of use by the captors' government, and the act of destroying for the sake of destruction, as distinguished from consumption or destruction in the course of use, is not such user as the statute contemplates.

The money in court is alone subject to distribution, and a decree will be entered accordingly.

LEWIS et al. v. AMERICAN NAVAL STORES CO.

HIBERNIA BANK & TRUST CO. v. LEWIS.

(Circuit Court, E. D. Louisiana. December 8, 1902.)

No. 13,088.

1. RECEIVERS—JURISDICTION OF FEDERAL COURT TO APPOINT—FOREIGN CORPORATIONS.

A federal court has jurisdiction to appoint a receiver for a corporation of another state, where, by appearing and pleading to the merits, such corporation waives its exemption from being sued out of the district of its domicile, and its action in submitting to the jurisdiction of the court cannot be overruled at the instance of a stockholder or creditor who was not a party to the original suit, but who has been permitted to intervene.

2. SAME—EFFECT OF APPOINTMENT—TITLE TO BILL AND RIGHT OF POSSESSION OF PROPERTY.

The effect of the appointment of a receiver for a corporation is to vest in him, as an officer of the court, a qualified title to all of the property of the corporation within the court's jurisdiction and the right of possession for purposes of administration and for the benefit of those ultimately shown to be entitled to it.

3. SAME—PROPERTY IN OTHER JURISDICTIONS.

While the appointment of a receiver does not confer upon him the right to sue in another jurisdiction to recover property or debts, the modern practice is to permit him to bring such suits as a matter of comity where such permission will not conflict with the rights of citizens or creditors in the state where the suit is brought; and the constant tendency of the courts is towards a more liberal policy, which recognizes the receiver's right to the possession of the property embraced by the decree appointing him, although situated without the territorial jurisdiction of the court making the appointment.

4. SAME—ANCILLARY SUITS.

The practice of bringing ancillary suits and obtaining the appointment of a receiver therein in different jurisdictions may properly be followed where the defendant is a corporation engaged in business and owning property in different federal districts and in different states; and, while the courts in which such auxiliary suits are brought are entirely independent in fact of the court of primary jurisdiction, in the exercise of their discretion and to the end of securing economy of administration and equality of distribution, they will treat their jurisdiction as ancillary.

5. SAME—SUITS FOR WINDING UP CORPORATION — COURT OF PRIMARY JURISDICTION.

Where a decree has been entered by a federal court appointing a receiver for a corporation of another state, which owns property in the district consisting in part of real estate, on a bill filed by stockholders and creditors for winding up its affairs, which the corporation has answered, submitting to the jurisdiction, such court should be recognized as the court of primary jurisdiction by all other courts in which other proceedings may be subsequently instituted having the same object in view, even those in the state in which the corporation was organized, where it conducts no business and has no property in such state, and but a single stockholder, holding one share of stock, to meet a requirement of the state laws.

6. FEDERAL AND STATE COURTS—PRIORITY OF JURISDICTION—APPOINTMENT OF RECEIVER.

A bill was filed in the circuit court of the United States for the Southern district of Alabama against defendant, a New Jersey corporation, which owned property in the district, and had complied with the laws of the state with reference to foreign corporations doing business in the state by filing a copy of its articles of incorporation and designating an agent on whom process might be served. Complainants were large stockholders, and also creditors, and prayed for the appointment of a receiver and the liquidation of the business of the corporation by the court. On the same day service was made an answer was filed by authority of the directors admitting the allegations of the bill and consenting to the appointment of a receiver, and on the following day a decree was entered making the appointment, and the property of the corporation was turned over to the receiver. *Held*, that such decree vested the receiver with the right to possession of property of the corporation situated in Louisiana, as against a different receiver, appointed by a state court of Louisiana in a suit instituted therein by another stockholder, in which the petition was not filed nor service made until a later date than in the federal court.

In Equity. Ancillary suit for liquidation of the American Naval Stores Company. On application for an order requiring the receiver to turn over property to a receiver appointed by other courts.

T. M. Stevens and J. H. Lyons, for plaintiffs.

Wm. C. Fitts, D. B. H. Chaffe, and E. J. Bowers, for petitioner Hibernia Bank & Trust Co.

J. P. Blair, for respondent J. J. Lewis.

Before SHELBY, Circuit Judge, and PARLANGE, District Judge.

SHELBY, Circuit Judge. This is a contest between two receivers, appointed by different courts, each claiming the right to the possession and control of the assets of the defendant corporation. To show the points in controversy, it is necessary to state the facts as shown by the pleadings and the evidence offered at the hearing.

The parties to the immediate controversy are J. J. Lewis, who was

appointed receiver by the United States circuit court for the Southern district of Alabama and by the United States circuit court for the Eastern district of Louisiana, and the Hibernia Bank & Trust Company, which has been appointed receiver of the defendant corporation by the civil district court for the parish of Orleans, state of Louisiana, and also by the United States circuit court for the district of New Jersey. J. J. Lewis, as such receiver, is now in the possession of the assets in question, and the Hibernia Bank & Trust Company, as receiver, seeks to obtain an order placing it in possession of such assets. Lewis' title as receiver will first be stated.

On September 25, 1902, D. R. Lewis, a citizen of the state of North Carolina, and W. P. Lewis, a citizen of the state of Alabama, residing in the Southern district of that state, filed their bill in the United States circuit court for the Southern district of Alabama, against the American Naval Stores Company, a corporation organized under the laws of New Jersey. Plaintiffs are stockholders in the defendant corporation, having \$20,000 of stock, and are creditors of the corporation to the amount of \$2,650. The capital stock of the corporation is \$250,000, but only \$106,000 of the stock has been issued and paid for. The debts of the corporation amount to about \$100,000. Its assets consist of real estate, part of which is situated in the Southern district of Alabama and part in the Eastern district of Louisiana,—that in Alabama worth about \$3,834.48, and that in Louisiana worth about \$12,659.74; of bills receivable and accounts, secured and unsecured, amounting to about \$125,000; of rosin in Florida worth about \$8,000, in Illinois, worth \$18,000, and in Kentucky, worth \$5,000; and other personal property in Mobile and in New Orleans. These facts appear by the bill, which elaborately states the grounds and reasons why it became and is necessary to appoint a receiver, and why it would be to the interest and advantage of the stockholders and creditors of the corporation to appoint one. The prayer is that a receiver may be appointed to take possession and control of all the assets, credits, and property belonging to the defendant company, and that the company may be liquidated, adjusted, and wound up under the supervision of the court, and for an injunction restraining any and all parties from prosecuting or instituting any suits against the defendant company, and for general relief. A subpoena in equity was issued on the day the bill was filed, and served on that date. On the same day (September 25, 1902) the defendant, the American Naval Stores Company, answered the bill, admitting its allegations, and consenting and agreeing that a receiver be appointed. It is shown in the answer that the board of directors of the defendant company, having had notice of such bill, had authorized and directed the president to file an answer consenting to the appointment of a receiver. The answer is under seal of the defendant corporation, and is verified by the president. The defendant corporation had complied with the constitution and laws of the state of Alabama by filing in the office of the secretary of state a certified copy of its articles of incorporation, designating its known place of business in Mobile, Ala., and an agent on whom process might be served. A foreign corporation may be sued in any county in Alabama where it does business. Const. Ala. 1901, art. 12, § 232; Ex parte

Schollenberger, 96 U. S. 369, 24 L. Ed. 853. On September 26, 1902, the bill and answer being submitted to one of the circuit judges of the Fifth circuit, a decree was rendered appointing J. J. Lewis receiver, as prayed for, with power and authority to take charge and possession of all the assets, real and personal, of the defendant, and with power to collect the debts due to the company from any and every source, and with the usual powers conferred on receivers. He was required to give and did give bond in the sum of \$100,000. It was further ordered, adjudged, and decreed that all stockholders, stock subscribers, and creditors were enjoined from instituting or prosecuting any suits against the company, and from interfering with or seeking to reach any of the assets or property of the defendant company, "except in this court and in this cause." On the same day—September 26, 1902—an ancillary bill addressed to the judges of the circuit court of the United States for the Eastern district of Louisiana by the same plaintiffs and against the same defendants—a similar answer by the defendants having been presented—was submitted to the same circuit judge, and a decree was signed assuming in that court ancillary jurisdiction of the cause, and confirming the appointment of J. J. Lewis as receiver. This ancillary bill and the decree thereon were received and filed in the office of the clerk of the United States circuit court for the Eastern district of Louisiana on September 29, 1902. On the same day similar ancillary bills and answers were presented to the same circuit judge as judge of the United States circuit court for the Northern district of Florida and as judge of the United States circuit court for the Southern district of Mississippi, and similar ancillary decrees were signed by him. On September 29, 1902, on similar ancillary proceedings, J. J. Lewis was appointed receiver of the defendant corporation by the United States circuit court for the Eastern district of Kentucky, by decree signed by one of the judges of that court. On October 3, 1902, on similar ancillary proceedings in the United States circuit court for the Northern district of Illinois (a judge of that court presiding), J. J. Lewis was appointed receiver of the defendant company.

The claim and title to the assets asserted by the Hibernia Bank & Trust Company as receiver must now be stated. Its claim is asserted in two separate petitions, which will be considered together. On September 26, 1902, Charles E. Pearce, a citizen of Mobile, Ala., filed a petition against the American Naval Stores Company in the civil district court for the parish of Orleans, La. He is a stockholder in the defendant company to the amount of \$1,000, being the owner of one share. The petition alleges that the company has assets in New Orleans, and that the president and secretary of the company have resided there during the last 18 months, and that none of the officers of the corporation are domiciled in New Jersey, except one director, who has never been present at any of the meetings of the directors, and who was elected and holds office solely to comply with the statute of New Jersey, which requires that one director of a corporation created under its laws should be a resident of the state. Irregularities in the management of the company are then alleged, and it is prayed that an injunction should be issued enjoining and restraining the defendant corporation and its agent from selling, pledging, or

alienating any of the property of the company. It is also prayed that the defendant be ordered to show cause why a receiver should not be appointed to take possession of the property and business of the defendant corporation, and that, after due proceedings, a fit and proper receiver be appointed, fully empowered to manage, control, conduct, or liquidate the affairs of the defendant. On the same day—September 26, 1902—the judge of the state court granted the writ of injunction, and also made an order that the defendant show cause on the 7th day of October, 1902, why a receiver should not be appointed as prayed for; and on the same day—September 26, 1902—citation was duly issued on the petition. A copy of the injunction was served by personal service on “M. A. Moses, director,” and a copy on “J. J. Lewis, secretary and treasurer,” on September 26, 1902. The citation and order were served September 27, 1902, by the sheriff of the parish, “by leaving a copy of the same at the office of the defendant corporation at No. 606 Commercial alley, in the hands of L. C. Bodit, clerk, the president and other superior officers being absent.” On October 27, 1902, Pearce’s application for the appointment of a receiver coming on to be heard in the district court for the parish of Orleans, that court rendered judgment appointing the Hibernia Bank & Trust Company receiver of the defendant corporation upon its furnishing bond in the sum of \$25,000, which was given, with full power and authority to “hold, administer, manage, and dispose of the property and income of the corporation in such manner as the court shall direct.” On October 30, 1902, Charles E. Pearce filed a bill in the United States circuit court for the district of New Jersey against the American Naval Stores Company, seeking to have a receiver appointed for the defendant corporation by that court. He alleged that he was a stockholder in the company, holding one share, and was a creditor having a claim against the corporation for more than \$2,000. He described the proceedings in the United States circuit court for the Southern district of Alabama and in the other United States courts in which a receiver had been appointed, and also the proceedings in the Louisiana state courts. On October 30, 1902, the New Jersey federal court, without notice to the defendant corporation, appointed the Hibernia Bank & Trust Company receiver of the American Naval Stores Company, with full power and authority to take possession and control of the assets, credits, and property of the defendant company wheresoever situated, and all papers and books of accounts, choses in action of every character, belonging to the said company. It was further ordered by the New Jersey court that the defendant show cause on the 10th day of November “why the appointment of said receiver should not be made permanent, and an injunction issue, as directed, to the said defendant”; and, cause having been shown, the question of making the receiver permanent by that court is still pending and undetermined. It is shown by affidavits offered that the debtors of the defendant corporation reside in the Southern district of Alabama, the Northern district of Florida, the Southern district of Mississippi, and the Eastern district of Louisiana, and that no debtor of the corporation resides in the state of New Jersey, and that the corporation owns no property situated in New Jersey; and that the notes, mortgages, and accounts due to the

defendant corporation which have come into the hands of J. J. Lewis as receiver amount to \$176,728.96; and that he has been actively performing the duties of his trust since his appointment on September 26, 1902.

1. The United States circuit court for the Southern district of Alabama unquestionably had jurisdiction of the case made by the bill. The fact that the defendant corporation was chartered under the laws of New Jersey does not, under the pleadings, affect the question of jurisdiction. If it be conceded that the corporation could not be sued, without its consent, except in New Jersey, the record in this case shows that it submitted to the jurisdiction of the court. It has been held by the supreme court that exemption from being sued out of the district of its domicile is a privilege which a corporation may waive, and which is waived, by pleading to the merits. It is so held in *Trust Co. v. McGeorge*, 151 U. S. 129, 14 Sup. Ct. 286, 38 L. Ed. 98, in which case a receiver was appointed for a defendant foreign corporation. The American Naval Stores Company having appeared and voluntarily submitted itself to the jurisdiction of the court, its action cannot be overruled at the instance of a stockholder or creditor, who was not a party to the original suit, but who has been permitted to intervene. *Trust Co. v. McGeorge*, supra; *Railway Co. v. McBride*, 141 U. S. 127, 11 Sup. Ct. 982, 35 L. Ed. 659; *Ex parte Schollenberger*, 96 U. S. 369, 24 L. Ed. 853; *Bank v. Morgan*, 132 U. S. 141, 10 Sup. Ct. 37, 33 L. Ed. 282; 5 *Thomp. Corp.* § 6860; *Winans v. Navigation Co.*, 6 *Blatchf.* 215, *Fed. Cas. No.* 17,862.

2. The decree appointing J. J. Lewis receiver vested in him a qualified title to the property of the corporation, together with the right of possession for the purpose of administration. 5 *Thomp. Corp.* § 6918. By this is not meant that the ownership of the property is changed, or even the right to possession as between the parties. The effect of the appointment is to put the property, from the time of the appointment, in his custody as an officer of the court for purposes of administration, and for the benefit of the party ultimately shown to be entitled to it. *Union Bank v. Kansas City Bank*, 136 U. S. 223, 10 Sup. Ct. 1013, 34 L. Ed. 341. The right to obtain the custody, control, and possession of all the property within the jurisdiction of the court making the appointment is conferred on the receiver by the decree.

3. In *Booth v. Clark*, 17 *How.* 322, 335, 15 L. Ed. 164, it was held that the appointment of a receiver by a court of chancery under a creditors' bill does not confer the right to sue in a foreign jurisdiction. In that case, which was decided in 1854, Mr. Justice Wayne said: "Our industry has been tasked unsuccessfully to find a case in which a receiver has been permitted to sue in a foreign jurisdiction for the property of the debtor." That case has been often cited to sustain the proposition that a receiver appointed in one state has no right to sue in another state. The doctrine is generally recognized that a foreign receiver has no right to sue in another state, but, while the right is denied, the modern practice is to permit him to bring such suits, on the ground of comity, in all cases where such permission will not conflict with the rights of citizens or creditors in the state where the suit

is brought. And the constant tendency of the courts is toward a more enlarged and liberal policy,—the recognition of the receiver's right to the possession of the property embraced by the decree appointing him, although situated without the jurisdiction of the court making the appointment. *Boulware v. Davis*, 90 Ala. 207, 8 South. 84, 9 L. R. A. 601; *Beach*, Rec. § 682; *High*, Rec. (2d Ed.) 241; *Gluck & B.* Rec. (2d Ed.) 42; *Gilman v. Ketcham*, 84 Wis. 60, 54 N. W. 395, 23 L. R. A. 52, 36 Am. St. Rep. 89; *Hurd v. City of Elizabeth*, 41 N. J. Law, 1; *Chandler v. Siddle*, 3 Dill. 477, Fed. Cas. No. 2,594; *Bank v. McLeod*, 38 Ohio St. 174. This tendency is so pronounced, and so well sustained by authority, that it is probable that the doctrine ultimately to be established will give to receivers the same right of action in all the states of the Union with which they are invested in the jurisdiction in which they are appointed. There can be no doubt but that the decree of the circuit court for the Southern district of Alabama of September 25th invested the receiver not only with a limited title to the property within the local jurisdiction of the court, but with a right that would be recognized, on the ground of comity, to sue for and recover any of the property or debts belonging or due to the defendant corporation outside of the Southern district of Alabama.

4. But Lewis' claim as receiver to hold the property against the contention of the receiver of the state court is not based alone on the decree of the circuit court of the Southern district of Alabama. On the same day that that decree was entered, a decree was rendered on ancillary proceedings in equity in the United States circuit court for the Eastern district of Louisiana and in other districts of the Fifth judicial circuit, as stated above. This procedure and practice of bringing auxiliary suits originated from the limitations imposed upon the territorial jurisdiction of the circuit courts, and from the fact that many railroads run into or through two or more states, constituting one property and one continuous line. 2 *Bates*, Fed. Eq. Proc. 617; *Southern Ry. v. Carnegie Steel Co.*, 176 U. S. 257, 20 Sup. Ct. 347, 44 L. Ed. 458; *Farmers' Loan & Trust Co. v. Northern Pac. Ry.* (C. C.) 72 Fed. 26. While the practice is especially applicable to such cases in which the title to real estate in different jurisdictions will be conveyed, it is applied also to cases involving the property of corporations engaged in business and owning property in different judicial districts and in different states. The courts in which the auxiliary suits are brought are entirely independent in fact of the court of primary jurisdiction. The end to be secured—the collection of all the assets of the corporation, and their uniform and equitable administration and distribution—moves the discretion of the court to treat its jurisdiction as ancillary, and to aid in the collection of the assets, and to transmit them to the court of primary jurisdiction; and this course secures equality among creditors and stockholders and economy in the administration. *Shinney v. Building Co.* (C. C.) 97 Fed. 9; *Towle v. Society* (C. C.) 60 Fed. 131; *Miles v. Association* (C. C.) 95 Fed. 919.

5. The first suit was brought in the circuit court of the United States for the Southern district of Alabama. That court has been recognized as the court of primary jurisdiction by the several federal courts in the

Fifth circuit and in the Sixth circuit in which auxiliary bills have been filed. The plaintiffs invoked, and the defendant consented to and acquiesced in, the jurisdiction of that court. Part of the defendant's property is situated in that district. The defendant's stockholders first organized an Alabama corporation, but subsequently obtained the charter in New Jersey for business reasons. It has complied with the constitution and laws of Alabama by filing with the secretary of that state a copy of its charter, and designated an agent on whom process may be served, and a place of business in that state. The bill that was filed in the United States circuit court of the district of New Jersey was exhibited by a single stockholder more than 30 days after the jurisdiction of the federal court in Alabama had attached and had been acquiesced in by the defendant. The defendant corporation has but one stockholder in New Jersey, and he holds but one share. No debtor to the corporation lives in New Jersey, and it owns no property in that state. In *Farmers' Loan & Trust Co. v. Northern Pac. Ry. Co.* (C. C.) 72 Fed. 31,—a case decided by four of the circuit justices,—several bills having been filed relating to the same corporation and its property, the primary jurisdiction of the court in which the first bill was filed was recognized; the court saying:

"But in view of what has transpired in these foreclosure proceedings,—especially in view of the fact that a portion of line of road owned by the Northern Pacific Railroad Company was and is within the state of Wisconsin, and at the time of the filing of the creditors' bill (in which the trustee in the mortgage was a coplaintiff) the Northern Pacific Railroad Company was operating its road through the Eastern district of Wisconsin, although that part of its line so operated belonged to another company, and was under lease to the Northern Pacific Railroad Company for ninety-nine years,—and in view of the further fact that the railroad company entered its appearance, and assented to the act of the circuit court for the Eastern district of Wisconsin in taking jurisdiction, and as such exercise of jurisdiction has been recognized by the circuit court in every district along the line of the Northern Pacific Railroad, and all parties, for the space of about two years, during which time many orders in the course of administration have been entered, we are of opinion that the circuit court for the Eastern district of Wisconsin has jurisdiction to proceed to a decree of foreclosure which will bind the mortgagor company and the mortgaged property, and ought, therefore, to be recognized by the circuit courts of every district along the line of the road as the court of primary jurisdiction; and that proceedings in the latter court, while protecting the rights of local creditors, should be ancillary in their character, and subordinate to the proceedings in the court of primary jurisdiction."

In view of the facts shown by the record, we think the court in which the first bill was filed should be recognized as the court of primary jurisdiction. 2 *Bates*, Fed. Eq. Proc. § 617.

6. But the claim of the Hibernia Bank & Trust Company does not rest alone on the decree of the New Jersey federal court. On September 26, 1902,—one day after the date of the decree of the federal court in Alabama,—Charles E. Pearce, a citizen of Mobile, Ala., living within the jurisdiction of that court, filed a petition in the civil district court for the parish of Orleans, La., against the defendant corporation. He sued as stockholder. His suit resulted in an injunction granted that day, and in service and citation served on September 27, 1902, and in the appointment of the Hibernia Bank & Trust Company as receiver

on October 27, 1902. It is contended by the Hibernia Bank & Trust Company that, inasmuch as the ancillary decree signed in Alabama by the circuit judge on September 26th did not actually reach the clerk's office in the Eastern district of Louisiana till September 29th, the state court first obtained jurisdiction of the assets of the defendant corporation situated within the Eastern district of Louisiana. Much that we have already said about the effect of the decree of the federal court in Alabama bears on this contention. The general rule is, undoubtedly, that the court which first takes cognizance of the controversy is entitled to retain jurisdiction till the litigation is ended, and to take possession of the property involved in the controversy to the exclusion of all other courts of concurrent jurisdiction. No other court can interfere with the property without permission of the court first acquiring jurisdiction. While this is indisputable, nice questions constantly arise as to when a court acquires jurisdiction, and as to which of two courts is entitled to hold and to administer and distribute the assets of a defendant. In an important case, *Woods*, Circuit Judge, gave controlling effect to the filing of the bill and the service of the subpoena in equity, and Circuit Justice Bradley to the obtaining actual possession of the property which was involved in the suit (*Wilmer v. Railway Co.*, 2 *Woods*, 410, Fed. Cas. No. 17,775); and in *Adams v. Trust Co.*, 15 C. C. A. 1, 66 Fed. 617, 620, the United States circuit court of appeals for this circuit approved the views expressed by Judge Woods that the actual seizure of the property involved was not necessary to the jurisdiction of the federal court to the exclusion of the jurisdiction of a state court of concurrent jurisdiction. In the latter case Judge Pardee, speaking for the court, held that the "views expressed by Judge Woods have been accepted and followed in this circuit at least, and we fully concur therein." That decision is controlling in this court. The late authorities sustain this view that priority of jurisdiction is dependent on priority of service (*Gluck & B. Rec.* [2d Ed.] 99); but many other cases make the jurisdiction depend on the priority of making the appointment. *Thomp. Corp.* § 6855.

The Alabama federal court first obtained jurisdiction by the filing of the bill and service of process, and by first appointing a receiver, and also by obtaining, through its receiver, actual possession of the property involved before the filing of the petition and service of process thereon in the state court. By the application, therefore, of any one of the rules stated, the Alabama federal court first acquired jurisdiction; and, having acquired jurisdiction of the controversy, and possession, through its receiver, of the property involved, the subsequent proceedings and decree in the state court conferred no authority or right on the receiver appointed by the latter court to take or obtain by suit the possession of the property. *Gluck & B. Rec.* (2d Ed.) 97.

A decree will be entered denying the petitions of the Hibernia Bank & Trust Company. Petitions denied.

PEERS v. NEVADA POWER, LIGHT & WATER CO.

(Circuit Court, D. Nevada. December 1, 1902.)

No. 729.

1. WRONGFUL DEATH—ACTION FOR DAMAGES—SUFFICIENCY OF COMPLAINT.

The statute of Nevada (Cutting's Comp. Ann. Laws, §§ 3983, 3984) which creates a liability for wrongful death where the act, neglect, or default causing such death "is such as would (if death had not ensued) have entitled the party injured to maintain an action and recover damages in respect thereof," and provides that the action shall be brought by the personal representative of the deceased, and how the proceeds recovered shall be distributed among certain kindred, and that "the jury in every such action may give such damages, pecuniary and exemplary, as they shall deem fair and just, and may take into consideration the pecuniary injury resulting from such death to the kindred as herein named," creates but a single cause of action, and not one in right of the deceased by survival, and another in right of the next of kin; and a complaint based thereon is not demurrable because it does not allege separately the damages resulting to the kindred or that any so resulted.

2. SAME—EXEMPLARY DAMAGES.

Nor is it necessary under such statute that the complaint should specify what portion, or whether any, of the damages prayed for are claimed as exemplary; the allowance of such damages, as well as damages resulting to the kindred, being a matter to be determined by the jury, in their discretion, from the evidence.

3. SAME—NAMING BENEFICIARIES.

The complaint in an action for wrongful death should state the names of the kindred of the deceased who are entitled to share in the recovery by the terms of the statute; but, where the names of kindred are so stated, it is not necessary to expressly negative the existence of relatives other than those named.

At law. On demurrer to complaint.

The complaint in this action among other things avers:

That Frank A. Wells died intestate at Reno, Nev., March 1, 1902; that plaintiff is the duly appointed and qualified administrator of his estate; that at the time of his death, and for a long time immediately prior thereto, the defendant in a careless, reckless and negligent manner maintained across the premises described in said complaint "electric wires, and conducted electricity upon and through said wires across said street, and the said wires were at the said times and place of insufficient caliber, capacity, material, insulation, height above ground, attachment, support, and general construction to safely conduct the amount of electricity with which they were at said times and place surcharged and overburdened by defendant."

(11) That on the 1st day of March, 1902, defendant knew and had notice that said wires were of insufficient caliber, etc., as above mentioned. Notwithstanding such knowledge and notice, the "defendant recklessly, negligently, and in willful disregard of and indifference to the personal safety of public travelers over the said Ninth street, and the personal safety of the said Frank A. Wells, deceased, while a traveler, at said time and place maintained, surcharged, and overburdened the said wires with a highly dangerous amount of electricity."

(12) That while said wires were recklessly and negligently maintained by defendant "the said Frank A. Wells, deceased, while traveling afoot upon the said Ninth street, and without fault or negligence upon his part, came in con-

¶ 2. Punitive damages for wrongful death, see note to *McGhee v. McGarley*, 44 O. C. A. 259.

¶ 3. See Death, vol. 15, Cent. Dig. § 64.

tact with the said wires, and was by the electricity with which the same were recklessly and negligently surcharged and overburdened by defendant as aforesaid then and there killed."

(14) That said Wells died, leaving surviving him a mother, sister, and a brother, whose names and ages are stated in the complaint.

(15) That by reason of the premises hereinbefore mentioned and pleaded, plaintiff, as the administrator of the estate of Frank A. Wells, deceased, has sustained damage in the sum of \$40,000.

To this complaint the defendant interposed a demurrer on several grounds; among others: (1) That the complaint does not state facts sufficient to constitute a cause of action. (2) That the 11th paragraph of the complaint is uncertain, in this: That it cannot be ascertained therefrom that the defendant knew or had notice of the matters therein set forth before the alleged injury. (3) That the tenth, eleventh, and twelfth paragraphs are uncertain, in that it does not appear therefrom whether the death of Wells was due "to the alleged careless, reckless, and negligent manner in which said wires were maintained across Ninth street, or to the amount of electricity with which they were surcharged and overburdened, or to the insufficient caliber, capacity, material, insulation, height above ground, attachment, support, or general construction of said wires." (4) That the complaint is uncertain, because it cannot be ascertained therefrom "whether said plaintiff seeks to recover pecuniary or exemplary damages, or both; nor does it appear therefrom the amount of each of said kinds of damages which he claims to have sustained." (5) That it does not appear therefrom whether Wells left surviving him a father or other relative than those mentioned in the complaint, or that said plaintiff has been damaged by any of the alleged wrongful acts of defendant." (6) That it does not appear therefrom that any pecuniary injury resulted to the plaintiff, or to any or all of the kindred of the said Wells." (7) That two causes of action—First, a cause of action which would have entitled the said Frank A. Wells to maintain an action in respect thereof; and second, a cause of action created by statute in favor of the kindred of said deceased—are improperly united in said complaint, and are not separately stated." (8) "That said complaint is uncertain, in that it cannot be ascertained therefrom what damages are claimed for the alleged cause of action which the said Frank A. Wells would have been entitled to maintain an action in respect thereof, and what damages are claimed in favor of the kindred of said Frank A. Wells, deceased."

Torreyson & Summerfield, for plaintiff.

A. E. Cheney (Van Ness & Redman, of counsel), for defendant.

HAWLEY, District Judge (orally). An action for the death of an intestate was unknown to the common law, and is of purely statutory origin. The unsatisfactory state of the common law, which denied any right to recover for death due to negligence or wrongful act, led to the passage of statutes giving a right of recovery in such cases. The English act of 1846 (9 & 10 Vict. c. 93), commonly designated as "Lord Campbell's Act," so often referred to, has served as a model upon which most of the statutes of the various states of the Union have been enacted. Statutes of this general character do not merely remove the operation of the maxim, "*Actio personalis moritur cum persona*," but give a new cause of action. The object of all statutes passed in conformity with the general purpose of the Lord Campbell act is to provide the means for recovering the damages caused by that which is in its nature a tort. The death of the party injured ceases to relieve the wrongdoer from liability for damages caused by the death. This is the main purpose and effect of all the statutes upon this subject. *Stewart v. Railroad Co.*, 168 U. S. 445, 449, 18 Sup. Ct. 105, 42 L. Ed. 537. "For want of a common-
119 F.—26

law remedy, statutes vesting in certain designated persons a right of action for injury resulting from death by negligence have been passed in different jurisdictions, and in the case of a death * * * the terms of the statute in force in the particular jurisdiction must be looked to in order to determine the right to sue, the form of action, the parties plaintiff and defendant, the conditions of liability, and the measure of damages." Patt. Ry. Acc. Law, § 350. It would, therefore, serve no useful purpose to review or refer to many of the cases cited by defendant, because most of them are based upon statutory provisions radically different from the act of this state requiring compensation for causing death by wrongful acts, neglect, or default, which reads as follows:

"Section 1. Whenever the death of a person shall be caused by wrongful act, neglect or default, and the act, neglect, or default is such as would (if death had not ensued) have entitled the party injured to maintain an action and recover damages in respect thereof, then, and in every such case, the persons who, or the corporation which would have been liable, if death had not ensued, shall be liable to an action for damages, notwithstanding the death of the person injured; and although the death shall have been caused under such circumstances as amount in law to a felony.

"Sec. 2. The proceeds of any judgment obtained in any action brought under the provisions of this act shall not be liable for any debt of the deceased: provided, he or she shall have left a husband, wife, child, father, mother, brother, sister, or child or children of a deceased child; but shall be distributed as follows: First—If there be a surviving husband or wife, and no child, then to such husband or wife; if there be a surviving husband or wife, and a child or children, or grandchildren, then equally to each, the grandchild or children taking by right of representation; if there be no husband or wife, but a child or children or grandchild or children, then to such child or children and grandchild or children by right of representation; if there be no child or grandchild, then to a surviving brother or sister; or brothers or sisters, if there be any; if there be none of the kindred hereinbefore named, then the proceeds of such judgment shall be disposed of in the manner authorized by law for the disposition of the personal property of deceased persons: provided, every such action shall be brought by and in the name of the personal representative or representatives of such deceased person; and provided further, the jury in every such action may give such damages, pecuniary and exemplary, as they shall deem fair and just, and may take into consideration the pecuniary injury resulting from such death to the kindred as herein named."

Cutting's Comp. Ann. Laws, §§ 3983, 3984.

This statute was construed by Judge Hillyer in *Roach v. Mining Co.* (C. C.) 7 Fed. 698. Without giving my approval to all the views expressed by him, it seems clear to my mind from the principles therein announced and the law applicable to the facts alleged that the general demurrer on the ground that the complaint does not state facts sufficient to constitute a cause of action should be overruled. I differ with Judge Hillyer in his construction of the act that "there are two causes of action,—two grounds upon which a recovery can be had,—one for the injury to the deceased, and one for the injury to the kindred named in the act." A careful reading of the entire act shows that there is but one cause of action, and this is given in section 1 (3983). The second section (3984) does not provide for another cause of action. It simply provides "how the proceeds of any judgment" obtained under section 1 shall be distributed, and, after declaring that "such action [that is, the action based upon the pro-

visions of the first section] shall be brought by and in the name of the personal representative or representatives of such deceased person," it then further provides that "the jury in every such action may give such damages, pecuniary and exemplary, as they shall deem fair and just, and may take into consideration the pecuniary injury resulting from such death to the kindred as herein named." This latter clause does not give another cause of action, but provides what proof may be given in the cause of action based upon the provisions of section 1. The first section creates the right of action, and the second section measures the recovery, and declares how the distribution must be made under the right created. There is but one cause of action stated in the complaint, to wit, a cause of action for the death of Frank A. Wells, caused by the alleged "wrongful act, neglect, or default" of the defendant.

The intention of the legislature must, of course, be given controlling effect; but in applying the ordinary and well-established canons of construction to be given to statutes it does not seem reasonable that the legislature intended to give two independent causes of action for the same injury, which causes of action would have to be separately stated in the complaint. This conclusion is supported by the reasoning of the court in *Brown v. Railroad Co.*, 22 N. Y. 191, 194; *Sweetland v. Railroad Co.*, 117 Mich. 329, 334, 75 N. W. 1066, 43 L. R. A. 568; *In re Mayo's Estate*, 60 S. C. 401, 411, 38 S. E. 634, 54 L. R. A. 660; *Seward v. Vera Cruz*, 10 App. Cas. 59, 70. This act is not a "survival act" in the strict sense of that term. It applies to cases of instantaneous death as well as to cases where the person injured survives the injury for a period of time. In this connection the law is well settled that in all cases where the death is instantaneous—where there is no appreciable length of time between the injury and the death—there cannot be any recovery for damages for the pain and suffering of the deceased. '8 Am. & Eng. Enc. Law, 866, 892. The statutes that have been passed upon this subject, while preserving the right of recovery, are by no means uniform, either as to the character, kind, or amount of damages, or by whom or for whose benefit they may be recovered. The evident intention of the legislature of this state, as appears from the language of the act itself, was to afford a complete and adequate remedy for the recovery in one action of all damages, whether compensatory or exemplary, which might result from the death of the deceased, and for the distribution of the damages recovered to the persons entitled to the same in the manner described in the second section of the act. In actions to recover damages for injuries received, the decided weight of the authorities is to the effect that it is not absolutely necessary, although it is held in several cases to be the better practice that plaintiff should set out in his complaint that he claims some or all of his damages to be punitive. It is sufficient if he makes a case by his pleading and proof upon the trial which will, under the law, entitle him to exemplary damages. *Railway Co. v. Holland*, 82 Ga. 257, 271, 10 S. E. 200, 14 Am. St. Rep. 158; *Express Co. v. Brown*, 67 Miss. 260, 265, 7 South. 318, 8 South. 425, 19 Am. St. Rep. 306; *Wilkinson v. Searcy*, 76 Ala. 176, 182; Rail-

road Co. v. Arnold, 84 Ala. 160, 169, 4 South. 359, 5 Am. St. Rep. 354; Hoadley v. Watson, 45 Vt. 289, 292, 12 Am. Rep. 197; Gustafson v. Wind, 62 Iowa, 281, 284, 17 N. W. 523; Davis v. Seeley, 91 Iowa, 583, 586, 60 N. W. 183, 51 Am. St. Rep. 356; Sloane v. Railway Co., 111 Cal. 668, 685, 44 Pac. 320, 32 L. R. A. 193; 1 Estee, Pl. § 1857; Suth. Dam. § 422.

In Gustafson v. Wind, supra, the court said:

"It is urged that no exemplary damages can be allowed, because the plaintiff demanded no such damages in her petition. We do not think such an allegation was necessary. Exemplary damages are not the subject of a claim in the sense that it is necessary to make averment thereof in the petition. The cause of action is founded upon injury to the person, property, and means of support. Where it is shown that damages have been suffered in any of these respects, it is in the discretion of the jury, in a proper case, to add to the verdict such a sum as they think proper as exemplary damages."

In Railway Co. v. Holland, supra, the court said:

"The point made that punitive damages could not be recovered because they were not claimed, 'eo nomine,' is wholly without merit. * * * It certainly cannot be necessary for the plaintiff to set out in his declaration, in so many words, that he claims some or all of his damages as punitive."

In Wilkinson v. Searcy, supra, the court said:

"Exemplary damages are not special damages which need be claimed in the complaint as a condition of their recovery."

In Hoadley v. Watson, supra, the court said:

"Exemplary damages grow entirely out of the nature of the act of the defendant for which the plaintiff recovers. They are given in enhancement, merely, of the ordinary damages, on account of the bad spirit and wrong intention of the defendant manifested by the act, and are recoverable with the ordinary damages, under the common allegation that the act declared for was done to the damage of the plaintiff."

The general rule as to the allowance of pecuniary or exemplary damages applicable to the present case is fairly and correctly stated in 8 Am. & Eng. Enc. Law, 924, as follows:

"Whether such damages are recoverable in an action for wrongfully causing the death of a person must depend upon the provision of the statute fixing the damages to be recovered. Where the statute expressly or by clear implication limits the damages recoverable to the pecuniary injury sustained by the beneficiaries by reason of the wrongful death, the damages must be compensatory merely, and nothing can be allowed as exemplary or punitive damages. When the statute does not so limit the recovery, it seems that such damages may be allowed where the proof shows that the death was due to the willful wrongdoing of the defendant, or to such gross negligence on his part as indicated a willful disregard of the rights of the deceased."

The objections urged against the fifteenth averment in the complaint that plaintiff, as administrator of the estate of Wells, "hath sustained damages," are untenable. They are purely technical, and apply only to the form, and not to the substance, of the averment. The death of Wells did not damage J. V. Peers individually, and there is no claim that it did. The action is not brought by him individually, but in his representative capacity as administrator of Wells' estate. Under the express provisions of the statute the action must be brought by the representative of the deceased, and he alone is en-

titled to recover damages, if any, resulting from the death of Wells by the wrongful act of the defendant,—not for his own individual benefit, but for the benefit of those to whom the damages recovered are to be distributed as provided for in the second section of the act. The averment in question follows approved forms in such cases (1 Estee, Pl. § 1841), and must be construed as having precisely the same meaning as if the words “hath sustained damages” had been left out, and in lieu thereof the words, “brings this action to recover from defendant \$40,000 damages for the death of the deceased.”

The manner in which the alleged negligence of defendant is stated in the complaint is sufficiently clear and certain. There are various causes or acts stated. Proof of either might be sufficient to enable plaintiff to sustain the averment of negligence. But defendant cannot complain because plaintiff saw fit to embrace other acts of the alleged negligence by the defendant. The eleventh paragraph of the complaint is not uncertain in so far as it alleges that “defendant knew and had notice” of the acts alleged to be negligent. It was unnecessary to allege when or how such notice was given. That is a matter of evidence which might be proven by direct notice, or be necessarily inferred from other facts established at the trial.

Is the averment in the fourteenth paragraph of the complaint, “that Wells left surviving him a mother, sister, and a brother,” giving their names and ages, sufficient to authorize the legal inference that he did not leave “surviving him a father, or any other relative than those named in said complaint”? This question must be answered in the affirmative. It is true that, for aught that appears upon the face of the complaint, the intestate may have left other kindred than those named therein; but it is equally true that there is nothing on the face of the complaint to indicate that he left surviving any other kindred than those named therein. The averment as made must be taken as true upon demurrer, and necessarily implies that there were no other kindred. Non constat, if there had been, they would have been mentioned; and, if this is not true in fact, the plaintiff should ask leave to amend the complaint in this particular. I am of opinion that good pleading requires such an averment as will advise defendant of the names of all the surviving kindred who are by the terms of the statute entitled to a distribution of the damages that may be recovered in the action; but I am also of opinion that where, as here, the existence of such kindred as authorizes a recovery is positively stated in such a manner as to authorize a recovery for their benefit, it is not necessary that plaintiff should be required to negative the existence of relatives other than those named by him. In *Barnes v. Ward*, 67 E. C. L. 392, 398, it was argued by counsel that the declaration should have negatived the existence of any parent or other relative of the deceased than those named. Maule, J., interrupting, “Did it appear that there was any other person entitled”? and, upon receiving a negative reply, said, “I do not see how the defendant can be injured by the supposed omission.”

The demurrer is overruled.

In re LESLIE.

(District Court, N. D. New York. January 3, 1903.)

1. **BANKRUPTCY—CONCEALING PROPERTY—EVIDENCE—SUFFICIENCY.**
The mere fact that there was a shrinkage of \$12,000 in the assets of a bankrupt within a year of his failure was not sufficient proof that he had that amount of property and concealed it from his creditors and the trustee, when his petition in bankruptcy was filed.
2. **WITNESSES—CREDIBILITY.**
A witness may be as thoroughly discredited by the inherent improbabilities of his testimony as by the direct testimony of other witnesses.
3. **BANKRUPTCY—APPLICATION FOR DISCHARGE—BURDEN OF PROOF.**
Where on an application for the discharge of a bankrupt, it was shown that he had received money after the filing of the petition, and without the authority of the trustee, and the disposition of such money was not disclosed, the burden of proving that it was paid over to the trustee was on the bankrupt.
4. **SAME—TESTIMONY AT CREDITORS' MEETINGS—ADMISSIBILITY.**
By Bankr. Act, § 7a, subd. 1 [U. S. Comp. St. 1901, p. 3424], the bankrupt is directed to "attend the first meeting of his creditors" and (sub-division 9 [U. S. Comp. St. 1901, p. 3425]) "when present * * * and at such other times as the court shall order, submit to an examination concerning * * * matters which may affect the administration and settlement of his estate; but no testimony given by him shall be offered in evidence against him in any criminal proceeding." *Held* that, though the testimony so given by the bankrupt proved a fraudulent concealment of property by him, it could nevertheless be used to defeat his application for discharge.
5. **SAME—GROUND FOR REFUSING DISCHARGE.**
If a bankrupt willfully and fraudulently conceals any of his property from the trustee, he is not entitled to a discharge.
6. **SAME—PREPONDERANCE OF EVIDENCE.**
A fair preponderance of the credible evidence is all that is needed to show a fraudulent concealment of property by a bankrupt, so as to defeat his discharge.
7. **SAME—EVASIVE ANSWERS BY BANKRUPT.**
While evasive and disingenuous testimony by a bankrupt is not a ground for refusing a discharge, it is a material consideration in determining his credibility when testifying as to what became of certain money.
8. **SAME—EVIDENCE—SUFFICIENCY.**
Evidence in an application for the discharge of a bankrupt examined, and *held* to show that certain money received by him after the filing of the petition had not been paid to the trustee.

This is an application to confirm the report of the special master to whom this matter was referred on the application of the bankrupt for a discharge. The special master has reported in favor of granting the discharge, and the question is, shall the report be confirmed, and the discharge granted?

White, Cheney & Shinaman, for bankrupt.
Benjamin Stolz, for opposing creditors.

RAY, District Judge. On or about October 1, 1900, the bankrupt filed his petition and schedules in bankruptcy. The schedules contained a list of his liabilities and an inventory of his assets. At the

¶ 5. See Bankruptcy, vol. 6, Cent. Dig. § 735.

first meeting of the creditors a trustee was elected, and he proceeded, as the evidence shows, to perform the duties of his office in a very loose and unsatisfactory manner. The bankrupt himself seems to have conducted his business in a very loose and unsatisfactory manner. The opposing creditors allege, and the petition and schedules of the bankrupt, with other evidence, demonstrate, that within a year of the failure of Leslie there was a shrinkage in his assets of at least \$12,000. From this fact the creditors claim that the court is justified in finding and holding that the bankrupt had that amount of property at the time of his failure, and has concealed the same from his creditors and from the trustee. The bankrupt does not explain or attempt to explain this shrinkage. His mode and manner of living are not shown. There is no pretense that he met with serious losses. The naked fact stands that there was a shrinkage in his assets of about \$12,000 within the time mentioned. It may be that the bankrupt had this money at the time of his failure, but there is no proof of the fact. He may have wasted the same in riotous and extravagant living or in gambling. The case is bare of proof on this question. The referee was justified in holding that there was no sufficient proof that the bankrupt had this amount of money at the time of his failure.

But a more serious question is presented from the evidence. It is alleged and shown that the bankrupt had in his employ at the time of his failure a person who was selling goods for himself or the bankrupt, and paying therefor to the bankrupt. It is immaterial how that fact was. At the time of the failure, and at the time of filing the petition in bankruptcy, at least \$113 was owing to the bankrupt, either from the persons who had had the goods, or from the salesman who made the sales. This salesman or agent, whichever he may be called, collected the money and turned it over to the book-keeper of the bankrupt; and she, in turn, paid it to the bankrupt after he had filed his petition in bankruptcy, and at about the time the trustee was appointed. It is claimed that the bankrupt did not turn this money over to the trustee, and that the trustee never accounted for it. On the hearing before the special master the bankrupt testified that he did turn this money over to the trustee, but he says that he cannot tell the time or place when he paid it over, or the circumstances under which the payment was made. He took no receipt. One witness testifies, in substance, that he was requested by the bankrupt not to say anything about this money. The trustee says that the money was paid over to him by the bankrupt, but he gave no receipt, and is unable to tell when or where the money was paid to him. He did not deposit it as a separate or distinct item, nor does he pretend that he deposited it at the time he received it. He claims that he took it to his office, and that it was put in the drawer of a clerk in the office, and remained there for several days, and that in the meantime he was making collections, and finally sold the whole stock, and that the money was all deposited in a lump sum. The trustee also testifies that he kept no book of account, but did keep some loose memoranda on slips of paper, and that these memoranda have all been lost or destroyed. When, where, or how such

loss occurred, is not explained. The law partner of the trustee was not sworn, nor were the clerks in the office. At one time the trustee testified, and his accounts show certain collections of certain accounts. If that testimony was true, and he collected accounts to the amount he said he did, then he never received this \$113 from the bankrupt, or, if he did, he never accounted for it or deposited it in the bank, as it was his duty to do. The special master evinced a disinclination to accept this statement of the bankrupt and of the trustee, but, as it was not contradicted directly, appears to have felt himself bound to accept the statement. A witness may be as thoroughly discredited by the inherent improbabilities of his testimony as by the direct testimony of witnesses. This court is not inclined to believe, and does not believe, on the evidence now produced, that this money was ever turned over by the bankrupt to the trustee. It is satisfied from the evidence now before it that the bankrupt and the trustee were in collusion. It may be, however, that the testimony of the law partner of the trustee and of his clerks, if they are called as witnesses, will be of such a nature as to convince this court that the money was paid over to the trustee as alleged. It seems incredible that an officer of this court, receiving that amount of money belonging to the creditors of this bankrupt estate, would allow it to lie around loose in his office in the manner described. If, however, it shall appear that this was the manner of doing business in that office, the court may be compelled to accept the statements of the witnesses; but it will not accept the evidence now before the court, or believe that such a loose manner of conducting business prevailed, or that the trustee was guilty of such gross violations of duty as the evidence and his own confessions, unexplained, establish, when given to secure a discharge for the bankrupt, and after the trustee has been discharged. The fact that this bankrupt received this money after his petition was filed, without authority of the trustee, which he had no right to do, being conceded, and its disposition not being disclosed, the burden of proof so far shifted that it was incumbent on him to establish by credible evidence that he paid it over to the trustee. *Asher v. Bank*, 7 Alb. Law J. 43; *Heinemann v. Heard*, 62 N. Y. 448; *Eichhold v. Tiffany*, 20 Misc. Rep. 680, 46 N. Y. Supp. 534; *Whitlatch v. Casualty Co.*, 149 N. Y. 50, 43 N. E. 405. This is the only transaction of the kind connected with that estate, and it is not credible that intelligent men have forgotten where or about when the payment of that money took place.

Again, in his report, the trustee says:

"From the time of the acceptance of my trust herein to the date of sale, I made strenuous efforts through my attorney, to collect in the outstanding accounts due and owing the bankrupt estate, and did succeed in collecting, after having sent out in the neighborhood of 800 letters, the sum of \$151.81."

Here is a plain statement that the trustee, as the result of strenuous effort through his attorney, collected on these accounts \$151.81 after sending 800 letters. No suggestion that \$113 of this sum was voluntarily paid in to the bankrupt before the appointment of the trustee, and prior to the sending of letters, and was speedily paid over, without any effort, "strenuous" or otherwise,—certainly not through

the efforts of his attorney. Is it true, in the face of this statement, that the trustee collected, through these strenuous efforts made through his attorney, only \$38.81 on accounts?

Again, in the summary this trustee reports the amount received on the lump sale of the stocks of goods at \$3,002.90. Then, "Cash received from D. Y. Leslie, balance on hand at the time of filing the petition," \$4.63. If the trustee received \$113 cash in addition from D. Y. Leslie, why did he not so state?

This trustee reports that in selling those goods in a lump sum for...	\$3,002 90
Receiving from the bankrupt, cash.....	4 63
Receiving from the bankrupt without any effort, if he did get that money from him.....	113 00
Collecting on accounts.....	38 81
And receiving on canceled insurance policies.....	27 96
Total	\$3,187 30

—He expended the sum of \$834.03. These facts should be considered seriously before giving the testimony of the bankrupt and this trustee full faith and credit.

Again, it has been urged that the evidence given by the bankrupt on his examination at the meetings of his creditors, and pursuant to the order of the court, cannot be used against him to defeat his discharge. No well-considered case has ever held such a doctrine. In *re Marx*, 4 Am. Bankr. R. 521, 102 Fed. 676, and *In re Logan*, 4 Am. Bankr. R. 525, 102 Fed. 876, have not been followed. They are expressly overruled in this circuit. In *re Gaylord*, 112 Fed. 668, 50 C. C. A. 415. By section 7a, subd. 1 [U. S. Comp. St. 1901, p. 3424], the bankrupt is required to—

"Attend the first meeting of his creditors if directed by the court or a judge thereof to do so, and the hearing upon his application for a discharge if filed, * * * and (subdivision 9 [U. S. Comp. St. 1901, p. 3425]) when present at the first meeting of his creditors and at such other times as the court shall order, submit to an examination concerning the conducting of his business, the cause of his bankruptcy, his dealings with his creditors and other persons, the amount, kind and whereabouts of his property, and, in addition, all matters which may affect the administration and settlement of his estate; but no testimony given by him shall be offered in evidence against him in any criminal proceeding."

This last clause was not written into the law as an encouragement to, or as a premium on, perjury. Nor was it placed there to license the bankrupt as a liar in the proceedings, and protect him from the consequences of his misstatements when he comes to apply for his discharge. The evidence cannot be used against him in any criminal proceeding. This is all. The proceedings on his application for a discharge are not criminal proceedings, or even criminal in their nature, like an action to recover a penalty or impose and enforce a forfeiture, but simply a civil proceeding instituted and being prosecuted by the bankrupt for a discharge from his debts; and, if the opposing creditors can show in such civil proceeding that the petitioner has committed any of the offenses mentioned in the bankruptcy act, the proceeding fails, and the discharge must be denied. No penalty or forfeiture is imposed, and no punishment follows. A discharge is not a matter of right, nor is its refusal the imposition of a penalty or a

forfeiture. The opposing creditors may show that the petitioning bankrupt has been guilty of the acts mentioned, by his admissions or statements made at any time. If, on the hearing at a time directed by the court, he admits under oath that he has willfully and fraudulently concealed his property from his trustee, that admission may be given in evidence against him on the hearing of his application for a discharge; but it cannot be made the basis of, or used against him on, a criminal charge and prosecution. A "criminal proceeding" is an action instituted and prosecuted by the state or sovereign power in its own name against a person who is accused of a crime, to punish him therefor. See Cent. Dict. tit. "Action"; Abb. Law Dict. tits. "Criminal Action" and "Criminal Case"; also "Civil Case."

"Criminal Action or Prosecution. A suit instituted for the enforcement of penal law, to secure the conviction and punishment of an offender. 'Prosecution,' alone, when used in the sense of a legal proceeding, and in ordinary context, sufficiently indicates that a proceeding for crime is intended, without a prefix of the word 'criminal.' See, also, 'Civil Action.'

"Criminal Case. An action, suit, or cause instituted to secure conviction and punishment for a crime. See 'Case.'

"Criminal cases are those which involve a wrong or injury done to the republic, for the punishment of which the offender is prosecuted in the name of the whole people. *Grimball v. Ross*, T. U. P. Charl't. 175."

A. sues in replevin for a horse, and shows prior possession as evidence of ownership. The defendant shows as a defense that the plaintiff obtained the horse feloniously, and never had any other possession. Is this a criminal proceeding? Clearly not. A civil action does not become a criminal proceeding because it becomes necessary for a party to prove that his opponent has committed a crime. No one is being prosecuted or proceeded against criminally. Hence the evidence given by the bankrupt may be given in evidence, if pertinent to an issue framed by the specifications of objections, on the hearing of the application for a discharge, either as an admission or in contradiction of his testimony given on such hearing.

The main purpose of the bankrupt law is to prevent preferences, and secure a fair and an equitable division of the bankrupt estate among the creditors, not to grant discharges. This end accomplished, the bankrupt is granted a discharge from all his debts. The attainment of the first is not to be sacrificed to the accomplishment of the last. If he willfully and fraudulently conceals any of his property from the trustee, he is not entitled to a discharge. The discharge is not denied as a penalty or a forfeiture because of the offense. The debtor has not performed one of the conditions precedent to obtaining a discharge from his debts. It is not necessary to establish this concealment of assets beyond a reasonable doubt, but by a fair preponderance of credible evidence only. The evidence must be satisfactory. In *re Gaylord*, 112 Fed. 668, 50 C. C. A. 415; *Ferry Co. v. Moore*, 18 Abb. N. C. 106, 102 N. Y. 667, 6 N. E. 293; *Wright v. Grant*, 6 N. Y. St. Rep. 362; *Davis v. Railroad Co.*, 56 Hun, 372, 10 N. Y. Supp. 460. Where the objecting creditors have made a prima facie case, the burden is on the bankrupt to so weaken it by credible evidence as to present a question of fact. Such is this case, and, when it was conclusively established that Leslie had this money after he filed

his petition, and the assignee's account failed to show its receipt by him, it was incumbent on the bankrupt to show by credible evidence that he paid it over to the trustee. This has not been done. Courts are not compelled to accept the bald statements of interested witnesses, or of any witness when his statements are laden with inconsistencies, or burdened with inherent improbabilities, or discredited by incriminating confessions. It is not probable this bankrupt was receiving and paying out so much money to divers individuals at this time that he fails to recollect any of the particulars of this alleged transaction with the trustee.

There is much in the evidence of this bankrupt displaying such gross ignorance, real or pretended, of his business affairs, that the court is justified in holding that his evidence is not entitled to credit on either of two grounds: First, such want of knowledge, memory, and intelligence as to make his testimony unreliable; or, secondly, such an unwillingness to disclose the truth as to wholly discredit him. His statements are destitute of those elements which command confidence and justify judgment based thereon. Remembering that in such a case as this, where two inferences may be drawn, one consistent with innocence, and the other pointing in the opposite direction, the court is bound to draw the first, still in this case it is impossible to draw any inference consistent with fair and honest dealing. The evasive and disingenuous testimony of the bankrupt is not a ground for refusing a discharge. In *re Gaylord*, 112 Fed. 669, 50 C. C. A. 415. But it is a most material consideration in determining his credibility when testifying this money was paid to the trustee. The presumption of innocence, even in a civil case, prevails until overcome by evidence; but, when overcome by the evidence of the witness himself or by testimony, it fails to have weight.

For these reasons, an order will be entered referring this matter back to Mr. Stone, with directions to take such pertinent and legal evidence as may be offered by either party, and with particular instructions to ascertain the facts as to the whereabouts of this \$113, and to obtain a copy of the bank account and deposit slips of this trustee.

UNITED STATES v. RIDENOUR.

(District Court, W. D. Virginia. December 13, 1902.)

1. INTERNAL REVENUE—TAX ON DISTILLED SPIRITS—PUNISHMENT OF FRAUD—EXEMPTION FROM LIABILITY—REPEAL OF STATUTE.

Rev. St. § 3257 [U. S. Comp. St. 1901, p. 2112], punishing distillers who defraud or attempt to defraud the United States of the tax on spirits distilled by them, is not repealed by Act March 3, 1877 (19 Stat. 393 [U. S. Comp. St. 1901, p. 2137]), providing for the establishment of a bonded warehouse exclusively for the storage of grape brandy, removal of such spirits thereto, their deposit and withdrawal, etc., and Act October 18, 1888 (25 Stat. 560 [U. S. Comp. St. 1901, p. 2141]), extending the provisions of the act of March 3, 1877, to distillers of all fruit brandies.

2. SAME—CONSTRUCTION OF STATUTE.

Rev. St. § 3257 [U. S. Comp. St. 1901, p. 2112], punishes every person engaged in carrying on the business of distiller who shall defraud or at-

tempt to defraud the United States of the tax on spirits distilled by him. *Held*, in view of the legislative intent, manifested by legislation for many years, that "spirits distilled" should include apple brandy, a distiller of apple brandy was properly indicted under section 3257 for an attempt to defraud the government of taxes due by him.

Thos. L. Moore, U. S. Dist. Atty.
Chas. A. Hammer, for defendant.

McDOWELL, District Judge. The question here arises on a demurrer to each of the two counts in a bill of indictment. The first count gives the defendant no sufficient notice of the offense with which he is charged, and the demurrer as to it should be sustained. The second count reads as follows:

"And the grand jurors aforesaid, on their oath aforesaid, do further present that the said T. A. Ridenour on the _____ day of _____, in the year 1901, in the said division of said district, and within the jurisdiction of said court, was engaged in the business of a distiller, and did then and there distill a large quantity of spirits, to wit, two hundred and eighty gallons of apple brandy, then and there subject to the internal revenue tax then imposed by law upon distilled spirits, and the said T. A. Ridenour then and there unlawfully did defraud and attempt to defraud the said United States of the tax on said spirits so produced by him as aforesaid, by using and disposing of said spirits before the said tax had been paid thereon as is required by the statutes in such cases made and provided, contrary to the form of the statute in such case made and provided, and against the peace and dignity of the United States. Thos. Lee Moore, United States Attorney."

The contention of counsel for defendant is that there is no statute which makes it a criminal or penal offense for the distiller to use or dispose of apple brandy without having first paid the internal revenue tax thereon. In the first place, it seems to me that the act of March 3, 1877 (19 Stat. 393 [U. S. Comp. St. 1901, p. 2137]), relating to the production of grape brandy, and punishing frauds connected therewith, as extended to distillers of apple brandy by act of October 18, 1888 (25 Stat. 560 [U. S. Comp. St. 1901, p. 2141]), is probably broad enough to cover the charge made in the indictment. However, the indictment does not seem to have been drawn under the above-cited provisions, and may be open to the objection that it does not negative the idea that the accused "disposed" of the brandy by removing it to a special bonded warehouse. The indictment was drawn under the statute found in section 3257, Rev. St. [U. S. Comp. St. 1901, p. 2112], taken from section 5, Act March 31, 1868 (15 Stat. 59), which reads as follows:

"Sec. 5. And be it further enacted, that every person engaged in carrying on the business of a distiller who shall defraud or attempt to defraud the United States of the tax on the spirits distilled by him, or any part thereof, shall forfeit the distillery and distilling apparatus used by him, and all distilled spirits and all raw materials for the production of distilled spirits found in the distillery and on the distillery premises, and shall, on conviction, be fined not less than five hundred dollars, nor more than five thousand dollars, and be imprisoned not less than six months, nor more than three years."

The contention is that this section does not apply to a distiller of fruit brandy, but only to distillers of whisky. This position does not seem to me to be tenable. To go no further back, it will be suffi-

cient to examine the language used in statutes enacted in 1864 and thereafter.

In the act to provide internal revenue, of June 30, 1864 (13 Stat. 223 et seq.) subsec. 16 of section 79 (page 253) requires that "distillers" pay \$50 for a license; but distillers of apples, grapes, and peaches, distilling less than 150 barrels per year, shall pay only \$12.50 for license. By section 55, a tax, in addition to the distillers' license, is required on all spirits of from \$1.50 to \$2 per gallon. In section 57 is a proviso "that brandy distilled from grapes shall pay a tax of twenty five cents per gallon." See, also, Act March 3, 1865 (13 Stat. 472), which amends the foregoing proviso by making the tax on grape brandy 50 cents per gallon, and by fixing the tax on brandy distilled from apples or peaches at \$1.50 per gallon. In the above statutes there can be no doubt that the word "distiller" included a distiller of apple brandy, and that "distilled spirits" included apple brandy.

In the act of July 13, 1866 (14 Stat. 98), at page 117, is the following, relating to licenses:

"Distillers shall pay one hundred dollars. * * * Provided that distillers of apples, grapes or peaches, distilling or manufacturing fifty and less than one hundred and fifty barrels per year from same, shall pay fifty dollars; and those distilling or manufacturing less than fifty barrels per year from the same, shall pay twenty dollars."

At page 157 of this same act, the tax on spirits is fixed at \$2 per gallon. Then follow numerous minute and exacting provisions to be complied with by distillers in the manufacture of spirits, and at page 163 is the following:

"And the commissioner of internal revenue is hereby authorized * * * to exempt distillers of brandy from apples, peaches or grapes exclusively, from such of the provisions of this act relating to the manufacture of spirits as in his judgment may seem expedient."

By amendment,—act of March 2, 1867 (14 Stat. 477),—the tax on grape brandy is reduced to \$1 per gallon. Clearly, in these statutes the word "distiller" includes a distiller of apple brandy, and the term "spirits" or "distilled spirits" includes apple brandy.

The act of March 31, 1868 (15 Stat. 59), repeals the tax on distilled spirits; but on July 20, 1868 (15 Stat. 125), was passed an "act imposing taxes on distilled spirits and tobacco, and for other purposes." This act (page 125) imposes a tax of 50 cents per gallon on "all distilled spirits." And it is provided that:

"The tax on brandy made from grapes shall be the same and no higher than that upon other distilled spirits; and the commissioner of internal revenue is hereby authorized * * * to exempt distillers of brandy from apples, peaches or grapes exclusively from such other provisions of this act relating to the manufacture of spirits as in his judgment may seem expedient."

Then follow numerous provisions relating to the manufacture of spirits. At page 150, § 59, a special tax is imposed on all distillers, in the following language:

"Distillers producing one hundred barrels or less of distilled spirits * * * within the year, shall each pay four hundred dollars; and if producing more than one hundred barrels, shall pay in addition four dollars for each such barrel produced in excess of one hundred barrels."

This act clearly imposes a tax of 50 cents per gallon on apple brandy, and requires a license tax to be paid by a distiller of apple brandy. And certainly in this act the word "distiller" includes the maker of apple brandy, and "spirits" includes apple brandy.

On April 10, 1869 (16 Stat. 43), an act was passed to amend the act "imposing taxes on distilled spirits" of July 20, 1868. Inter alia, this amendment provides:

"That section fifty nine be further amended so as to require that distillers of brandy from grapes, peaches and apples exclusively, producing less than one hundred and fifty barrels annually, shall pay a special tax of fifty dollars, and, in addition thereto, the tax of four dollars per barrel."

This amendment certainly puts beyond all question the fact that in passing the act to impose taxes on distilled spirits, of July 20, 1868, congress intended that the word "distiller" should embrace a distiller of apple brandy, and that "distilled spirits" should include apple brandy.

The next act that I find is one of June 6, 1872, "to reduce * * * internal taxes and for other purposes" (17 Stat. 230 et seq.), which amends the act of July 20, 1868, as amended by the act of April 10, 1869, inter alia, by repealing at page 244 so much of the above-mentioned section 59 as imposes a special tax on distillers and the tax of \$4 per barrel. But the tax of 50 cents per gallon on all distilled spirits, including apple brandy, imposed by the act of July 20, 1868, is not repealed, and it is at page 238 increased to 70 cents per gallon.

I have no copy of the first edition of the Revised Statutes (1873). In 18 Stat. pt. 3, I find nothing that seems to bear on the question in hand, though in section 16, at page 310, of an act to amend existing customs and internal revenue laws, of February 8, 1875 [U. S. Comp. St. 1901, p. 2095], a penalty is denounced against those who carry on the business of a distiller without having given bond, or with intent to defraud the government. Nothing in this act suggests that a distiller of apple brandy is not included within its intent.

The next statute which seems to have any bearing is the one heretofore mentioned, of March 3, 1877 (19 Stat. 393 [U. S. Comp. St. 1901, p. 2137]), which relates only to the production of grape brandy, and to the punishment of frauds connected therewith. The reason which led to the enactment of this statute is not entirely clear to me, but I presume that under regulations made by the commissioner of internal revenue, exempting brandy distillers from certain requirements of the law, frauds were being committed by grape brandy distillers. This statute would, of course, have little or no bearing on the subject in hand, but for the act of October 18, 1888 (25 Stat. 560 [U. S. Comp. St. 1901, p. 2141]), extending its application to apple-brandy distillers, which will be further considered hereafter.

At this juncture the Revised Statutes (edition of 1878) were published. By section 3247 [U. S. Comp. St. 1901, p. 2107], "Every person who produces distilled spirits * * * shall be regarded as a distiller." By section 3251 [U. S. Comp. St. 1901, p. 2108], the tax on all distilled spirits, excepting only such as were deposited in a bonded warehouse prior to August 1, 1872, is fixed at 70 cents per gallon. By section 3254 [U. S. Comp. St. 1901, p. 2111], "All prod-

ucts of distillation, by whatever name known, which contain distilled spirits or alcohol, on which the tax imposed by law has not been paid, shall be considered and taxed as distilled spirits." By section 3255 [U. S. Comp. St. 1901, p. 2111], "The commissioner of internal revenue * * * may exempt distillers of brandy made exclusively from apples, peaches or grapes from the provisions of this title, relating to the manufacture of spirits, except as to the tax thereon. * * *" By section 3257 [U. S. Comp. St. 1901, p. 2112], punishment is provided, in the same language as that used in the act of March 31, 1868 (15 Stat. 59), for a distiller who defrauds or attempts to defraud the government of the tax on the spirits distilled by him. It is true that many of the sections of title 35, Rev. St. [U. S. Comp. St. 1901, pp. 2038-2312], seem to apply only to spirits distilled from grain or molasses; but the sections hereinabove adverted to must, by every principle of construction, having in view the earlier legislation, be held to relate to distillers of apple brandy as well as to makers of other spirits.

The act to amend the laws relating to internal revenue, of March 1, 1879 (20 Stat. 327 et seq.; 1 Supp. Rev. St. 231 [U. S. Comp. St. 1901, p. 2060]), is entirely confirmatory of the above construction. In section 5 (page 335, 20 Stat.), relating, inter alia, to surveys of distilleries to change the spirit-producing capacity, it is provided that, under certain circumstances, surveys of "stills in a distillery of apples, peaches or grapes exclusively," may be made without taking certain measurements. See, also, section 6 (pages 340, 341, 20 Stat.), making special provision as to "distillers of fruit."

The act of May 28, 1880 (1 Supp. Rev. St. 284 [U. S. Comp. St. 1901, p. 2180]), does not seem to affect the question under consideration.

The next act that may seem to bear on the point is that of October 18, 1888 (1 Supp. Rev. St. 632 [U. S. Comp. St. 1901, p. 2141]), heretofore mentioned, which extends the act of March 3, 1877 (19 Stat. 393 [U. S. Comp. St. 1901, p. 2137]), relating to grape brandy, to apple and peach brandy. But I do not perceive that it is of any importance in this discussion. Neither of these statutes, even by implication, repeals the tax on apple brandy, or repeals the law providing punishment for a distiller who defrauds or attempts to defraud the government of the tax; and neither affords any reason for holding that the word "distiller" does not include a manufacturer of apple brandy.

The act of August 27, 1894 (2 Supp. Rev. St. 266), does not further affect the question under consideration than to make it even more certain that apple brandy is included under the term "distilled spirits." By this act (pages 325, 326) the tax on "all distilled spirits" is fixed at \$1.10 per gallon, and upon spirits in bond the time of payment of the tax is extended to eight years "from the date of the original entry for deposit in any distillery warehouse, or from the date of original gauge of fruit brandy deposited in special-bonded warehouses." I have found nothing in the subsequent legislation, including the acts of the First session of the 57th congress (1901-1902), which has any bearing on the point in question.

It seems, therefore, that section 3257, Rev. St. [U. S. Comp. St. 1901, p. 2112], stands unrepealed; that a manufacturer of apple brandy is included in the meaning of the word "distiller"; and that apple brandy is embraced in the term "spirits distilled." This statute punishes by fine and imprisonment the distiller who defrauds or attempts to defraud the United States of the tax on the spirits distilled by him, or of any part thereof. The second count in the indictment charges an offense in the words of the statute, and specifies with sufficient certainty the manner of the commission of the alleged offense. The demurrer to the second count must be overruled.

UNITED STATES v. McLEOD.

(Circuit Court, N. D. Alabama, S. D. December 6, 1902.)

1. OFFICERS—INTIMIDATION—PAST DUTY.

Rev. St. § 5399 [U. S. Comp. St. 1901, p. 3656], providing for the punishment of any person who "endeavors to influence, intimidate or impede any officer" in any court of the United States "in the discharge of his duty," does not include an assault committed on a United States commissioner, who had previously held defendant to answer on a criminal charge to be considered by a federal grand jury, where such assault did not occur until some months after the final termination of the proceedings before such commissioner.

2. SAME—UNITED STATES COMMISSIONER—COURTS.

The fact that an assaulted United States commissioner does not hold a "court of the United States" does not prevent such assault from constituting an offense under Rev. St. § 5399 [U. S. Comp. St. 1901, p. 3656], punishing any person who, by threats or force, obstructs or impedes the due administration of justice in any court of the United States, if such assault in fact could or did obstruct justice in the particular case in the circuit or district court.

3. SAME—INDICTMENT—PRESUMPTION.

Where, in an indictment for obstructing justice, it was alleged that, after defendant was held to the federal grand jury by United States commissioner, defendant committed an assault on such commissioner, but the indictment did not allege that the proceeding in which defendant was held was still pending in the federal, circuit, or district court at the time of the assault, it would be presumed that the matter had been concluded before the assault.

4. SAME—OBSTRUCTING JUSTICE.

Since the United States commissioner, after having held a person accused to answer to the federal courts, has no further duty to perform in the matter, a subsequent assault committed by such accused on the commissioner, induced by the latter's act, does not constitute an "obstruction of justice," within Rev. St. § 5399 [U. S. Comp. St. 1901, p. 3656], providing for the punishment of every person "who corruptly, or by threats or force, obstructs or impedes, or endeavors to obstruct or impede the due administration of justice" in any court of the United States.

The third count of the indictment is the only count insisted on, and reads as follows:

"And the grand jurors aforesaid upon their oaths aforesaid do further present that on the 20th day of June, 1900, a case came on for hearing before G. B. Randolph, a United States commissioner for the Northern district of Alabama, to wit, the case of the United States against A. N. McLeod on a charge of violating section 5440 of the Revised Statutes of the United States

[U. S. Comp. St. 1901, p. 3676], and that on the final hearing of said cause the said G. B. Randolph, as such United States commissioner as aforesaid, who had full power and authority to act as such United States officer, made an order requiring the said A. N. McLeod to make and execute a bond for his appearance at the next term of the circuit and district courts of the United States for the Southern division of the Northern district of Alabama. the said A. N. McLeod well knowing that the said G. B. Randolph was such officer as aforesaid, and well knowing that he was duly authorized to make such order; and the grand jurors do further present that on, to wit, the 30th day of October, 1900, the said A. N. McLeod did go upon the highway and unlawfully did threaten and assault the said G. B. Randolph, the said officer as aforesaid, for the reason that the said G. B. Randolph, as such officer, had required the said A. N. McLeod to execute a bond for his appearance before the grand jury of the United States as aforesaid, contrary to the form of the statute in such case made and provided, and against the peace and dignity of the United States."

The defendant demurred on numerous grounds, which resolve themselves into the objections that the count shows that the commissioner had fully and completely discharged his duty before the assault; that it did not appear that there was any proceeding pending before the commissioner, to be influenced or impeded, at the time of the alleged assault; that it did not appear that there was any proceeding pending or thereafter coming before the commissioner, to be influenced by the alleged assault; that the commissioner does not hold any court of the United States; that the indictment charges no offense against the laws of the United States.

Thos. R. Roulhac, U. S. Dist. Atty., and N. L. Steele, Asst. U. S. Dist. Atty.

Knox, Acker & Blackmon, for defendant.

JONES, District Judge (after stating the facts as above). The first clause of section 5399 of the Revised Statutes [U. S. Comp. St. 1901, p. 3656] deals with "endeavors to influence, intimidate, or impede, any witness or officer, in any court of the United States, in the discharge of his duty." It is the discharge of duty which this clause seeks to protect. There can be no discharge of duty, to be influenced in any way, when there is no duty to be performed. Neither a duty discharged in the past, nor the motives which induced it, can, in the nature of things, legal or moral, be recalled or influenced in any wise by a subsequent assault, not contemplated by him who performed the duty at the time it was discharged. The assault here charged clearly does not fall within this clause.

The remaining clause provides for the punishment of every one "who corruptly, or by threats or force, obstructs, or impedes, or endeavors to obstruct or impede, the due administration of justice therein,"—that is, "in any court of the United States." The word "therein," here used as synonymous with "in any court of the United States," qualifies the preceding words "due administration of justice," and necessarily restricts their meaning, when we remember that this is a penal statute, to particular cases as they arise in court. But for the restraining influence of the word "therein," the words "due administration of justice" might perhaps be held to include practices subversive of the general administration of justice, regardless of their effect upon any particular case. As here used, the words "the due administration of justice therein" mean the enforcement of the law of the land in individual cases brought or sought to be brought before the courts.

Justice is administered, in the sense of this statute, only by bringing rights or wrongs, and the persons or things concerned in them, before a judicial tribunal, and there dealing with each particular case as it arises. Every instrumentality or power, the exercise of which is proper or necessary to the accomplishment of any of these ends, is part and parcel of "the due administration of justice." Every unlawful act, specified in the statute, which interferes with or obstructs the normal and proper operation of any of the instrumentalities or powers which the law provides for bringing a matter before a judicial tribunal, deciding it after it is there, and enforcing the judgment rendered, constitutes, as to such matter, either an impediment or an obstruction, or an endeavor to obstruct or impede, "the due administration of justice," within the meaning of the statute.

The defendant insists the assault cannot be an obstruction to justice, or an endeavor to obstruct it, "in any court of the United States," because a commissioner who conducts a preliminary examination does not hold any court of the United States. *Todd v. U. S.*, 158 U. S. 278, 15 Sup. Ct. 889, 39 L. Ed. 982. When a commissioner examines and holds a defendant to bail, he performs a necessary step in the final administration of justice in the circuit or district court. The fact that the assaulted commissioner did not himself hold "any court of the United States" cannot withdraw the unlawful act from the grasp of the statute, if what was done to the commissioner could or did obstruct justice in the particular case in the circuit or district court.

The government insists the defendant is guilty, because he had been held to answer before the circuit and district courts where his case was pending at the time of the assault, and that the assault was an endeavor to impede, or an obstruction to, "the due administration of justice" in that case in the circuit or district court. The indictment, being silent as to the pendency of the case in the circuit or district court, cannot be aided by intendment. The presumption would be that the matter had been concluded there before the assault was made. If, however, the case were pending in the circuit or district court at the time of the assault, it could not bring the defendant within the mischief prohibited by the statute. An assault upon one who never had any authority or duty in the case pending in the circuit or district court, or whose relations to the case had ended before the assault, and who consequently could not, by the discharge of any function or power committed to him, exert any influence over the conduct or fate of the case in the circuit or district court, cannot constitute either endeavors to impede or an impediment to or an obstruction of justice "therein." Justice can be obstructed or influenced only by obstructing or impeding those who seek justice in a court, or those who have duties or powers in administering justice "therein." The commissioner at the time of the assault had no power to exercise, nor any duty to perform, which could be influenced by the assault. There was nothing he could do or leave undone, "in the discharge of his duty," which could exert the slightest influence upon the trial or decision of the case in the circuit or district court. The "due administration of justice therein" cannot be obstructed or impeded after it has run its course.

It is next insisted that the direct and ordinary effect of violence

upon the commissioner, because of past discharge of duty, being to influence and intimidate him in its future discharge, the defendant's unlawful act must necessarily amount to an endeavor to obstruct, or an obstruction to, "the due administration of justice," within the meaning of the statute. As we have observed, unless there is some case pending in a court, or sought to be brought "therein," there is nothing as to which "the due administration of justice" can be influenced or obstructed "therein." This statute does not create the offense of obstructing justice in general or in the abstract. Justice, in the meaning of the statute, is administered only in particular cases which are brought or sought to be brought before the court. If the unlawful act, done with reference to a particular case pending or contemplated to be brought before a judicial tribunal, does not obstruct the administration of justice "therein," no offense is committed, under this statute, though the evil effect of the unlawful act may militate against the administration of justice in some other case. Certainly a person cannot be guilty of obstructing justice, under this statute, in a case as to which he has done or intended nothing unlawful. The defendant can be held guilty here for acts done with reference to a particular case, only by holding the assault, induced because of the decision in that case, to constitute a continuing force, which ripens into a crime by relation to some other case. If the statute can fasten upon this assault, which related to a past transaction, and locate its effect upon some other case, totally disconnected from that as to which the unlawful act was done, the defendant could be held guilty, because of the doing of the one unlawful act as to one case, of as many other obstructions to justice as there were cases then pending or thereafter arising in which the discharge of duty could be directly affected by his act, though he had done or intended nothing unlawful concerning them, or, for that matter, may have been ignorant of their existence. Neither the reason nor the letter of the statute, nor any known rule of construction, permits the court to impart such fearful elasticity to a penal statute, as against a defendant. *Pettibone v. U. S.*, 148 U. S. 197, 13 Sup. Ct. 542, 37 L. Ed. 419.

There are other considerations quite persuasive of the correctness of the above views. The statute under which this indictment is found was passed March 2, 1831. If it covered assaults upon officers of court, or any other person engaged "therein" in the administration of justice, because of past discharge of duty, would congress have thought it necessary to pass any subsequent statute on the subject? That congress did not deem this section to cover assaults upon court officers, or others engaged "therein" in the administration, because of past discharge of duty, is apparent from its legislation 40 years afterwards, in the act of April 20, 1871, now section 5406 of the Revised Statutes [U. S. Comp. St. 1901, p. 3657]. This is the first instance in our criminal laws where an injury done any one on account of past discharge of duty in the courts is made a penal offense. This statute does not include court officers within its protection, but specifically restricts it to parties, witnesses, and jurors. Why, in dealing with the evil of assaults for past discharge of duty in the courts, has congress omitted officers of the court, and provided only for protection

against such evil of parties, witnesses, and jurors? This later statute would have been entirely unnecessary if the government's contention as to the proper construction of section 5399 of the Revised Statutes [U. S. Comp. St. 1901, p. 3656] is correct. The terms of this later statute are persuasive, at least, to show that section 5399 [page 3656] does not cover this case. The uniform policy of congress, as disclosed by its legislation since the foundation of the republic down to the present hour, with the exception noted in section 5406 [page 3657], has been to leave the protection of officers of court against assaults on account of past discharge of duty to the operation of the laws of the states, and the restraining influence of the power of the courts of the United States "to punish contempts of their authority." Whether the assault, under the circumstances disclosed by the record, constitutes a contempt which should be summarily dealt with, is a matter which will be taken up and considered hereafter.

The demurrers are sustained. As the act charged cannot constitute an indictable offense against the United States, the judgment will be that the defendant go hence without day.

CADY v. ASSOCIATED COLONIES.

(Circuit Court, N. D. California. November 3, 1902.)

No. 13,284.

1. REMOVAL OF CAUSES—PROCEEDINGS AFTER REMOVAL—VACATING JUDGMENT.

Where at the time a cause was removed into a federal court a judgment had been rendered against the defendant, but the state court had power under the statute to vacate the same, the federal court was vested on the removal with the same power.

2. SAME.

Where a cause has been properly removed into a federal court, that court cannot remand it for the purpose of having a motion to vacate a default judgment, rendered against defendant before the removal, determined by the state court.

3. SPECIAL APPEARANCE—FILING PETITION FOR REMOVAL—EFFECT.

The appearance of a defendant in a state court to file a petition and bond for removal is special, and is not a waiver of the right to object to the jurisdiction of the state court over him.

4. FEDERAL COURTS—JURISDICTION—DETERMINING VALIDITY OF SERVICE ON FOREIGN CORPORATION.

The authority of a federal court into which a cause has been removed to determine whether the state court, by the service made, acquired jurisdiction over the defendant, a foreign corporation, to render judgment against it, is neither derived from nor limited by the laws of the state; nor is such court concluded by the decision of the state court thereon.

5. FOREIGN CORPORATIONS—JURISDICTION IN SUIT AGAINST—VALIDITY OF CONSTRUCTIVE SERVICE.

Constructive service on a foreign corporation under a state law applicable to corporations doing business in the state will not confer jurisdiction, where at the time of such service the corporation is not doing business in the state.

¶ 5. Service of process on foreign corporations, see note to *Eldred v. American Palace Car Co.*, 45 C. C. A. 3.

On motion of defendant to quash the service of summons, recall an execution, and vacate a default and judgment entered by a state court before removal of the cause.

Goodwin & Goodwin and E. A. Bolton, for plaintiff.

W. F. Williamson, for defendant.

MORROW, Circuit Judge. This action was commenced in the superior court of this state, for the county of Lassen, by the plaintiff, to recover from defendant the sum of \$6,000 and interest, claimed to be due on a contract for the use of water for irrigation purposes during the years 1898, 1899, and 1900. The complaint was filed in the state court on February 5, 1902. It is alleged in the complaint that the defendant is a foreign corporation, having its office and principal place of business in the city of New York, state of New York; that from July 27, 1897, up to and including the time of the filing of the complaint, the defendant has been engaged in carrying on the business of farming agricultural lands in Lassen county, state of California; that the defendant has failed to designate a person residing in the state upon whom process issued by authority or under the law of the state may be served; and that the defendant has failed to execute and file any such designation in the office of the secretary of the state, as provided by an act of the legislature of the state of California entitled "An act in relation to foreign corporations," approved April 1, 1872, and the acts supplementary and amendatory thereof. Section 1 of the act of April 1, 1872, as amended by the act of March 17, 1899 (Statutes and Amendments of the Codes of California 1899, p. 111), provides as follows:

"Section 1. Every corporation heretofore created by the laws of any other state or foreign country, and doing business in this state, shall, within ninety days after the passage of this act, and any corporation hereafter created by the laws of any other state or foreign country and doing business in this state, within forty days from the time of commencing to do business in this state, designate some person residing in this state upon whom process, issued by authority by or under any law of this state, may be served, and within the time aforesaid shall file such designation in the office of the secretary of state, and a copy of such designation, duly certified to by the secretary of state, shall be sufficient evidence of such appointment and of the due incorporation of such corporation, and it shall be lawful to serve on such person so designated, or in event that no such person is so designated then on the secretary of state, any process issued as aforesaid. Such service shall be made on such person so designated, or the secretary of state, in such manner as shall be prescribed in case of service required to be made on foreign corporations, and such service shall be deemed a valid service thereof on such corporation."

It is claimed that the summons issued upon the complaint filed in this case and served upon the secretary of state on the 27th day of February, 1902, was a legal constructive service, under this statute. On the 2d day of April, 1902, the plaintiff had the default of the defendant entered in the clerk's office of the superior court of Lassen county, and on the 3d day of April, 1902, the court filed its findings of fact and conclusions of law; upon the same day entering a judgment in favor of the plaintiff and against the defendant in the sum of \$6,945, and costs of suit, taxed at \$11. On the 20th

of September, 1902, the defendant appeared by counsel and filed a motion with the clerk of the court to recall the execution issued in the case, to vacate and set aside the default and judgment, and quash the service of summons. The motion was supported by the affidavit of W. E. Smythe, the president of the corporation defendant. In this affidavit it is averred:

"That said defendant, the Associated Colonies, is, and for more than five years last past has been, a corporation organized and existing under the laws of the state of New York, and that the business for the carrying on of which it was incorporated and the objects of the incorporation of said company were to colonize, irrigate, and sell lands for homes and farming purposes, and to buy, sell, and deal in mortgages, bonds, and securities. That ever since its incorporation the said defendant has had its office and principal place of business in the city of New York, in the state of New York. That affiant is now, and was at all the times hereinafter mentioned, and ever since its incorporation, the president of the said defendant corporation. That prior to the 1st day of January, 1900, said defendant company had owned certain real and personal property in the county of Lassen, state of California, and for a period of about one year prior thereto had, through its tenants and agents, cultivated a small portion of its said lands in the said county of Lassen, state of California, but never at any time, or ever at all, carried on, transacted, or did any business in the state of California, other than the cultivation of said portion of its said lands as aforesaid. That on or about the 2d day of January, 1900, the said defendant corporation transferred, sold, and conveyed all of its said property, real and personal, in the state of California, and abandoned all intention of carrying on business in the state of California, and since said date has neither owned nor been in possession or use of any property, real or personal, of any kind, in the state of California. That since said 2d day of January, 1900, the said defendant has not done or carried on any business in the state of California, and has not been doing business in the state of California, and was not at the commencement of this action, or at the date of the attempted service of summons herein, or at the date of the said default or of said judgment, engaged in any business, trade, or calling in the state of California, and was not on either of said dates doing its or any business in the state of California, and did not on either of said dates, or ever or at all, since the 2d day of January, 1900, maintain any office or agent in the state of California. That the summons in this action was never personally served upon said defendant corporation, or upon any of its officers or agents, and that affiant, individually or as president of the said defendant corporation, never knew that this case had been begun by plaintiff against said defendant until on or about the 8th day of May, 1902, when he was advised that the said plaintiff had recovered a judgment against said defendant corporation; but even then affiant did not know upon what plaintiff based his claim or brought his suit, or when the suit had been begun, or where. That affiant was not fully informed of the facts or particulars of plaintiff's claim, or of the nature of his cause of action, or of the amount of the judgment, or its date, or where or when the suit was brought, until on or about the 1st day of August, 1902, when he was advised of those facts by W. F. Williamson, Esq., his attorney, who had made inquiry in that regard at his instance and request."

It is further averred that the defendant is advised by its attorney that it has a good, valid, meritorious, and legal defense on the merits.

On the same day that defendant filed its motion to recall execution, vacate and set aside the judgment, and quash the service of summons, it presented its petition to the court for removal of the case to this court, alleging diverse citizenship, and that the amount involved exceeded the sum of \$2,000, exclusive of costs and interest; and, upon giving the proper bond, the case was brought to this court.

The matter now before the court is the motion to recall the execu-

tion, vacate and set aside the judgment, and quash the service of summons. The determination of this motion depends upon the question whether the service of process made upon the secretary of state gave the superior court of Lassen county jurisdiction over the defendant. Section 1 of the amended act of the legislature of March 17, 1899, providing for the service of process upon the secretary of state, is made applicable to any corporation created by the laws of any other state or foreign country, and "doing business in the state." The defendant was a corporation created by the laws of the state of New York, and it had not designated any person residing in this state upon whom the process might be served. If, then, the defendant was "doing business in this state," the service of process on the secretary of state was sufficient, under the statute, to obtain constructive service upon the defendant. Was the defendant "doing business in this state"? It is objected that this court cannot examine into this question, on the ground that it had already been judicially determined by the state court that it had such jurisdiction. It would be a sufficient answer to this objection to say that when this case was removed to this court the superior court of Lassen county had authority, under section 473 of the State Civil Code of Procedure, to relieve the defendant from the judgment entered in the case. That section provides, among other things, that:

"The court may * * * also upon such terms as may be just, relieve a party or his legal representative from a judgment, order, or other proceeding taken against him through his mistake, inadvertence, surprise or excusable neglect: provided, that application therefor be made within a reasonable time, but in no case exceeding six months after such judgment, order, or proceeding was taken. When from any cause the summons in an action has not been personally served on the defendant, the court may allow, on such terms as may be just, such defendant or his legal representative at any time within one year after the rendition of any judgment in such action, to answer to the merits of the original action."

The judgment by default was entered on April 3, 1902. Defendant's motion to vacate and set aside the default judgment and to quash the service of summons was made on September 20, 1902, or within six months after the judgment and order was entered. The state court had authority, while the case was still pending in that court, to determine upon such a showing whether the defendant was entitled to be relieved from the judgment or not, and upon the removal of the case that authority was vested in this court.

The suggestion of the plaintiff that the case be remanded to the state court to have this motion determined cannot be entertained. This court cannot abdicate its authority or duty in any case in favor of another jurisdiction. *Hyde v. Stone*, 20 How. 170, 175, 15 L. Ed. 874. Moreover, the appearance of the defendant in the state court, under the circumstances, was not a waiver of objection to the jurisdiction. The appearance must be treated as a special appearance to secure the removal of the case to this court. *Railway Co. v. Brow*, 164 U. S. 271, 279, 17 Sup. Ct. 126, 41 L. Ed. 431. But the authority of this court to determine whether the state court had jurisdiction of the defendant to make the order and enter the judgment contained in the record has a wider scope than the power conferred upon the

state court to set aside defaults, as provided in section 473 of the State Code of Civil Procedure. In *Goldey v. Morning News*, 156 U. S. 518, 523, 15 Sup. Ct. 559, 30 L. Ed. 517, the supreme court of the United States declared that this authority was not limited by the laws of the state, but was dependent upon its constitutional jurisdiction under the laws of the United States. The court said:

"The jurisdiction of the circuit court of the United States depends upon the acts passed by congress pursuant to the power conferred upon it by the constitution of the United States, and cannot be enlarged or abridged by any statute of a state. The legislature or the judiciary of a state can neither defeat the right given by a constitutional act of congress to remove a case from a court of the state into the circuit court of the United States, nor limit the effect of such removal."

In that case the defendant was a corporation organized and existing under the laws of the state of Connecticut, and was engaged in doing business in that state, having no place of business, officer, agent, or property in the state of New York, where service of summons in the case was made upon the president of the corporation, a citizen and resident of the state of Connecticut. The service of summons was made upon the president while he was temporarily in the state of New York. Such a service had been held valid by the court of appeals of the state of New York, but invalid by the circuit courts of the United States held within that state. In the supreme court the latter opinion was upheld. The court, speaking upon this subject, said:

"It is an elementary principle of jurisprudence that a court of justice cannot acquire jurisdiction over the person of one who has no residence within its territorial jurisdiction, except by actual service of notice within the jurisdiction upon him, or upon some one authorized to accept service in his behalf, or by his waiver, by general appearance or otherwise, of the want of due service. Whatever effect a constructive service may be allowed in the courts of the same government, it cannot be recognized as valid by the courts of any other government. *D'Arcy v. Ketchum*, 11 How. 165, 13 L. Ed. 648; *Knowles v. Gaslight Co.*, 19 Wall. 58, 22 L. Ed. 70; *Hall v. Lanning*, 91 U. S. 160, 23 L. Ed. 271; *Pennoyer v. Neff*, 95 U. S. 714, 24 L. Ed. 565; *York v. Texas*, 137 U. S. 15, 11 Sup. Ct. 9, 34 L. Ed. 604; *Wilson v. Seligman*, 144 U. S. 41, 12 Sup. Ct. 541, 36 L. Ed. 338. For example, under the provisions of the constitution of the United States and of the acts of congress, by which judgments of the courts of one state are to be given full faith and credit in the courts of another state or of the United States, such a judgment is not entitled to any force or effect unless the defendant was duly served with notice of the action in which the judgment was rendered, or waived the want of such notice. Const. art. 4, § 1; Acts May 26, 1790, c. 11 (1 Stat. 122 [U. S. Comp. St. p. 677]), and March 27, 1804, c. 56 (2 Stat. 299; Rev. St. § 905 [U. S. Comp. St. p. 677]); *Knowles v. Gaslight Co.* and *Pennoyer v. Neff*, above cited."

These views of the supreme court with respect to the invalidity of a constructive service of process must, of course, be considered in connection with the admitted fact that the defendant was not doing business in the state of New York. The decision is cited mainly for the purpose of showing that the circuit court must determine for itself the validity of a service of process in a given case, whatever may be the law of a state, or its interpretation by the courts of a state, under which a valid service of process may be claimed.

This brings us to the consideration of the final question in this

case. The state has the right to exclude foreign corporations from doing business in the state, and, where they are not excluded, their right to engage in business within the state depends upon the laws of the state granting the permission. It follows that where the state provides by law that such a corporation doing business in the state must designate some person residing in the state upon whom the process must be served, and, in default of such designation, service of process may be made upon the secretary of state, such service is valid only when the corporation is actually doing business in the state. It is not valid when the corporation has withdrawn from the state, and has ceased to do business within the state. *St. Clair v. Cox*, 106 U. S. 350, 1 Sup. Ct. 354, 27 L. Ed. 222; *Swann v. Association (C. C.)* 100 Fed. 922; *Friedman v. Insurance Co. (C. C.)* 101 Fed. 535.

The affidavits introduced in this case in support of the motion under consideration show conclusively that the defendant had not been doing business in this state for more than two years when service of process was made upon the secretary of state. The fact that there was some claim against the defendant, remaining from its former business in the state, is not sufficient. It must be engaged in transacting some substantial part of its ordinary business. *U. S. v. American Bell Telephone Co. (C. C.)* 29 Fed. 37, 41.

The motion of the defendant to quash the service of summons, recall the execution, and vacate and set aside the default and judgment, is granted, and the action dismissed. *Railway Co. v. Brow*, 164 U. S. 271, 280, 17 Sup. Ct. 126, 41 L. Ed. 431.

CASSIDY FORK BOOM & LUMBER CO. v. ROARING CREEK & C. R. CO.

(Circuit Court, N. D. West Virginia. August 28, 1902.)

1. EQUITY—SUFFICIENCY OF ANSWER.

Various exceptions to the answers of defendants in a suit in equity considered and overruled.

2. CORPORATIONS—INSOLVENCY PROCEEDINGS—PURCHASE OF CLAIMS.

A creditor of an insolvent railroad company is not entitled to a discovery in respect to the prices paid for claims against the company by its president, who purchased for a third person having full right to buy the same, unless a conspiracy to defraud stockholders and creditors is first shown, and especially where such claims have been previously considered and allowed by a master.

In Equity. On exceptions to answers.

B. M. Ambler, for plaintiff.

E. D. Talbott, for defendant.

JACKSON, District Judge. This case is now heard upon the exceptions to the answer of Henry C. Terry, E. J. Burwind, and Charles Heebner. As Mr. Terry is the president of the company, and has been for some years, the court will first dispose of the exceptions to his answer, for the reason that the ruling upon the exceptions will sub-

stantially dispose of the exceptions to the answers of the other defendants.

The first exception filed by the plaintiff's counsel to the answer of Mr. Terry is to the answer of paragraph 4 of the bill. It is not necessary for the court to refer to paragraph 4 except to say that the answer of Mr. Terry specifically denies each and every averment of paragraph 4 of said bill, except so far as they are expressly admitted in his answer. Replying to that portion of the bill referring to traffic agreement, he expressly says that there was no traffic agreement. Replying to that part of the bill which states that the \$28,000 was made up by a fair average from 1896 of about \$10,000 per year, and giving an average of disbursements of about \$10,500 per year, as shown by the report, etc., the answer expressly says that the claim is not made up by giving the total receipts as an average and giving the average of disbursements, but is made up from the actual receipts and actual disbursements in connection with the operation of the said railroad, all of which are fairly and honestly stated and accounted for, which appears from an inspection of the master's report, the proofs of which were laid before him and allowed by him, and that the report further shows that there is a large amount due from the receiver, Thomas Fisher, to the defendant Terry. For the reasons assigned, the court overrules exception No. 1 to paragraph 4.

In reference to exception 2 to paragraph 4, in regard to the \$150,000 bonds and interest, the court overrules that exception, for it clearly appears from the answer of the defendant Terry how those bonds were acquired, and by whose money they were purchased. It is a question of fact to be determined upon the hearing whether or not the statements in his answer are true. The defendant Terry expressly denies that the bonds were held as collateral for any obligation of the railroad company.

Exception No. 3 to paragraph 4 as to the mechanics' liens, amounting to \$3,542.10, is overruled, for the reason that the answer states that they were just items of liens against the railroad company, and were purchased by him as trustee for E. J. Burwind, upon a fair and proper consideration. The question whether or not he paid the face value of those liens is, in the view of the court, not a matter for fair and proper consideration, for the reason that it clearly appears in other proceedings in this case that the railroad company was bankrupt, and was in the hands of a receiver, and its obligations, securities, and judgment liens against it were far below the face value of them. It is not to be presumed, in dealing with a bankrupt, that the purchaser would be expected to pay anything like the face value of its obligations, especially when it appears that the purchaser, Burwind, was in no wise connected or associated with the company. Though a conspiracy and combination is alleged between Burwind and the others, yet the answer denies in strong terms the existence of any such conspiracy or combination.

As to exception No. 4 to the answer, which states that, as to material used for the construction of the railroad, amounting to \$12,054.34, the said Terry did not pay as much as \$8,000 on account thereof, and the answer does not refer to such allegation, or make any

response in regard thereto, is overruled. The defendant, in his answer, states that the items making up that amount are all fair, just, and at fair prices, and that the claims therefor were purchased by this defendant as trustee for Burwind. A reference to the master's report shows that this claim of \$12,054.34 was supported by the evidence of Mr. Terry and Mr. Fisher. The latter had the vouchers therefor, as the court is informed by the master, although it does not appear upon the face of his report. But, if this were not so, Burwind had a right to purchase the \$12,054.34 claim for \$8,000, if he could get it, unless an allegation of fraud can be established by proofs. If, upon the hearing of the case upon its merits, the allegation of fraud is fully established, then it might be that it would be the duty of the court to more fully investigate the question of the consideration of these various claims purchased by Burwind.

As to exception No. 5 to the answer, in regard to the charges of \$63,000 for building the railroad $4\frac{1}{2}$ miles, at \$15,000 a mile, the answer of the defendant states that the building of the road and the expenditure of the money was authorized by a decree of the court at the price mentioned. This is a matter that has been disposed of by a former order of the court, and the bill here filed cannot be treated as a bill of review reviewing the decree of the court for allowing that claim, even if it was within the time to do so, but the court is of the opinion that the answer is a sufficient reply to that allegation of the bill.

Exception No. 6 of the plaintiff to the answer relates to the book accounts, amounting to \$112,572.05, reported by the master in favor of Terry, trustee, includes claims, all of which except about \$68,000 were acquired by said Terry not exceeding 50 cents on the dollar, and charges that the said Terry wholly fails to respond to such matter, and has not answered whether or not he acquired such claims at a discount or at the percentage specified. The answer states that the amount of \$112,572.05 was just and proper and fair claims against the railroad company, and were purchased fairly from the owners and holders thereof with the moneys of the said Burwind. This exception is overruled, for the reason that the answer states that they were purchased with the moneys of Burwind, and that the claims were just and proper against the railroad company. The defendant Burwind had a right to go into the market and purchase the claims upon such terms as the holders of the claims were willing to accept. These claims, as appears from the master's report, were passed upon by him and allowed, and vouchers were produced before the master, as I learn from him, showing the different items, stating the aggregate sum.

Exceptions Nos. 7, 8, 9, and 10 are covered by the concluding portion of respondent's answer, and therefore are overruled.

Exception No. 11, referring to the interrogatories, are questions all of which have been noticed and passed upon and disposed of in the first six exceptions to this answer, and are fully covered by that portion of the answer to which the first six exceptions apply.

It is apparent to the court that there is no equitable ground for the discovery asked for in this case, unless upon the hearing of this case the evidence should establish a combination and fraud upon the

part of Terry, Burwind, Heebner, and Fisher to sacrifice this property of the railroad company to the detriment of its stockholders and creditors. In addition to this, it is perfectly competent for the plaintiffs to introduce evidence in this case, and to call the defendants to the stand and make them testify, and answer questions independent of the answers.

There is an exception found in the papers to the answer of E. J. Burwind. The court is of the opinion that Mr. Burwind has answered fully, and, inasmuch as he adopts the answer of Mr. Terry in regard to the matters in controversy, and relying upon his answer to the various exceptions, the court is of the opinion to overrule all the exceptions to Mr. Burwind's answer.

There is also an exception to the answer of Thomas Fisher. The court is of the opinion that the exceptions are not well taken. His answer refers to the answer of the defendant Terry, and says that the facts set forth in the answer of said Terry he believes them to be true, and so avers. He denies all the averments of the fourth paragraph of the said bill, except so far as they are expressly admitted in the answer of Henry C. Terry, trustee. The fact is that the proceedings in this case were pending before the master from time to time for several years past, and it is apparent to the court that little or no interest was manifested by the stockholders, or by the plaintiff in this action, for they did not attend before the master when he was making up his report, and never in any way suggested to the master that they wished to be heard by him in reference to the claims against the railroad company, though every one interested had full notice of the time and taking of the account.

Pending these proceedings before the master, Wamelsdorf, who was general manager of the plaintiff company, and must have known of all matters of interest in which his company was concerned, filed his cross-bill in his own behalf on the 26th day of June, 1897, and he stated in his cross-bill that the only assets held by Henry C. Terry, trustee, are the matters in litigation in this suit,—that is, in the original suit,—and in his capacity as trustee he had no other assets out of which your orator can realize his claims; thus showing a familiarity with the assets in the hands of Terry, trustee. Subsequently Wamelsdorf dismissed his cross-bill on the 12th day of December, 1901. The court must conclude that the company, the plaintiff in this action, as well as the said Wamelsdorf, who was the general manager, was cognizant of the proceedings before the master, and that, if they had any interest in contesting the claims of Burwind, Terry, and the other parties, they should have appeared before the master and have done it.

H. B. CLAFLIN CO. v. FURTICK.

(Circuit Court, D. South Carolina. December 4, 1902.)

1. FORECLOSURE OF CHATTEL MORTGAGE—TEMPORARY RECEIVERSHIP—POWER OF COURT.

A federal court of equity has power, on a preliminary application, without notice, in a suit to foreclose a chattel mortgage, to take the mortgaged property into its custody through the marshal or a receiver for the purpose of preserving the status quo, where, in the exercise of its discretion, it deems such action necessary to protect the rights of the parties.

2. SAME—REVIEW OF ORDERS IN SAME COURT.

A federal judge, on the return to a rule on a defendant in a foreclosure suit to show cause why a receiver should not be appointed and an injunction granted, cannot review the action of another judge, sitting in the same court, in appointing a temporary receiver and entering a restraining order pending the hearing on such rule.

3. SAME—PARTIES—MORTGAGE TO TRUSTEE.

Where a chattel mortgage securing a single debt is taken to a third person named as a trustee, he is merely an agent of the creditor, and the latter may maintain a suit to foreclose in his own name.

4. SAME—JURISDICTION IN EQUITY—STATUTORY REMEDY.

A federal court of equity is not without jurisdiction of a suit to foreclose a chattel mortgage because the mortgagee had the right under the state statute to take possession of and sell the property on condition broken.

5. SAME—APPOINTMENT OF RECEIVER—GROUNDS.

A chattel mortgage on a stock of goods gave the mortgagee the right of possession through a cashier, to be appointed by the trustee to whom the mortgage was executed, who was to receive the proceeds of all sales, and, after deducting sufficient to pay current expenses, to apply the remainder on the mortgage debt. The mortgagor made a tender of the amount he claimed to be due on the mortgage, and on its refusal discharged the cashier and took possession of the stock. By operation of law also the mortgagee was entitled to possession on a breach of the conditions of the mortgage. *Held*, that under such facts the court would appoint a receiver in a suit to foreclose the mortgage to take possession of and hold the property pending a determination of the questions at issue, where the amount due on the mortgage, the value of the stock, and the solvency of the defendant were all matters in dispute.

In Equity. Suit to foreclose chattel mortgage. On application for appointment of a receiver and for an injunction.

Allen J. Green, for complainant.

Wm. H. Lyles and W. D. Mayfield, for defendant.

SIMONTON, Circuit Judge. This case now comes up on the return to a rule to show cause why a receiver be not appointed, and why the temporary injunction heretofore issued be not made permanent. In order to understand the case, a brief statement is necessary. William F. Furtick is a citizen of South Carolina, a merchant resident and doing business in the city of Columbia. Having become embarrassed, he employed Messrs. P. H. Nelson and W. D. Melton, attorneys, and instructed them to visit New York, and open negotiations with his creditors. These gentlemen visited New York, and finally consummated an arrangement with the H. B. Claflin Company, the

chief creditor of Furtick, whereby they obtained an amount of cash sufficient to purchase the claims of the other creditors, and secured a promise from that company to let Furtick have goods from time to time to a sum not exceeding \$5,000, so that he could continue in business. With the money so provided by the H. B. Clafin Company, these gentlemen purchased the other outstanding claims against Furtick on such terms as could be had with each separate creditor, the discounts varying in almost every instance. Upon reporting to Furtick the result of their effort and the contract made with the H. B. Clafin Company, their action was entirely approved by him. As a part of the arrangement with the H. B. Clafin Company, and to secure it in full, Furtick executed a mortgage of his stock of goods, furniture, and fixtures. This mortgage, at the request of the Clafin Company, was executed to W. D. Melton, Esq., styled their "trustee." This mortgage recites that Furtick is indebted to W. D. Melton, trustee, for merchandise sold and delivered and moneys loaned to him at divers times and in various sums, amounting in the aggregate approximately to the sum of \$23,000, and that he (Furtick) may become further indebted to the said Melton, trustee, at divers times thereafter in various sums, amounting in the aggregate to not more than \$5,000, with interest on all invoices of merchandise and on all sums of money from the time when same are payable. Now, to secure the same he mortgaged all his stock of merchandise, office and store furniture and fixtures in his establishment at Columbia, and all such merchandise, office and store furniture and fixtures as may from time to time hereafter be acquired in lieu and place of those above mentioned in the current business of said establishment. Among the covenants of the mortgage was this: That, after deducting from the daily sales, the current expenses, and a reasonable sum for the personal expenses of the mortgagor, the remainder of all such sales shall be paid over to William D. Melton, trustee, on account of the indebtedness secured by the mortgage, and to this end W. D. Melton shall appoint a cashier, selected by himself, to receive all cash receipts, and, after making the deductions provided as aforesaid, to pay the remainder to Melton, trustee. The mortgage provides that the indebtedness is to be paid within six months from its date, and in default of that, or on breach of any covenant in the mortgage, that Melton can enter, etc., as in the usual form of mortgages. This mortgage was duly executed and recorded, and the scheme put in operation. It continued for some time, some modifications being introduced, not material now to be mentioned, until October 17, 1902, when Furtick tendered to W. D. Melton, trustee, the sum of \$789.12, as payment in full of his entire indebtedness under the mortgage, after allowing him credit for sums paid from time to time, and demanded a receipt in full. This tender Mr. Melton declined. Thereupon Furtick dismissed the cashier, no longer accounted for the sales, and conducted the business on his own account entirely; whereupon the H. B. Clafin Company filed its bill for foreclosure against Furtick, praying also for the appointment of a receiver and an injunction. Upon presentation of the verified bill of complaint, his honor the district judge, presiding in the circuit court, passed an order di-

recting the marshal forthwith to take possession of the property described in the bill and the proceeds thereof, and to hold the same until the further order of the court; that defendant do show cause on a day fixed why the prayer of the bill be not granted, and a receiver appointed, and the injunction issued; that defendant be restrained from intermeddling with the mortgaged property, or in any way changing the status thereof or of its proceeds, until the further order of the court,—issuing the ordinary restraining order in the meantime. The defendant is also ordered to deliver the property to the marshal, and is given leave to move to vacate or modify the order on two days' notice. Subsequently, by stipulation between counsel, the defendant was authorized to conduct the business, reporting daily under oath the amount of the sales, and depositing the same, after deducting clerk hire, to the credit of the marshal, in a bank in Columbia.

The defendant has made his return, as follows:

1. He denies the jurisdiction of the court upon a preliminary application, without notice, to order the marshal to take possession of property in the possession of defendant and of the proceeds thereof, and to order the defendant to turn over the said property to said marshal. Having obeyed this order, he asks that it be rescinded. Perhaps no practice is better established in courts of equity than that of taking into the custody of the court property the subject-matter of litigation, and preserving the status quo by holding it for the benefit of all parties. And this practice is frequently exercised in cases of foreclosure of mortgages even where provision is not made, as is made in this case, that the net profits of the mortgaged property belong to the mortgagee. *Kountze v. Hotel Co.*, 107 U. S. 378, 2 Sup. Ct. 911, 27 L. Ed. 609; *Shepherd v. Pepper*, 133 U. S. 626, 10 Sup. Ct. 438, 33 L. Ed. 706; *American Nat. Bank v. Northwestern Mut. Life Ins. Co.*, 32 C. C. A. 275, 89 Fed. 612; *Central Trust Co. v. Chattanooga, R. & C. R. Co.*, 32 C. C. A. 241, 94 Fed. 282. Whether for this purpose it uses a receiver, or its own marshal, or any one of its other officers, the custody is the custody of the court. Such a course makes no change of title, decides no right; it simply preserves the status quo. This is always a matter wholly within the discretion of the court, and it is adopted when the court thinks it for the best interests of all concerned. If there be an abuse of this discretion, it may be reviewed in an appellate court. As this part of the return is directed to the action of the district judge sitting in this court, I have no right to review it, even if I did not concur in his view of the necessity or expediency of the act. But, considering all the circumstances of the case as then presented to him, I can see no possible objection to the course pursued by him. The question now before the court is whether, in the light of the return and the affidavits now in its possession, the custody of the court will continue. That will be discussed hereafter.

2. The next paragraph of the return says that this court is without jurisdiction at this stage of the proceedings, and before the time for answering has expired, to require the defendant to show cause why the prayer of the bill should not be granted, and is without juris-

diction to grant any relief that would be appropriate only on the final adjudication of the case. If by this is meant that the case is not ripe for final hearing, and that defendant is entitled to his day in court on the merits, it is unquestionably true. But the defendant in this part of the return has wholly misconceived the terms of the rule, and has omitted in his quotation some very important language, which modifies and controls the language of the rule. He is directed to show cause why the prayer of the bill be not granted, and (that is to say, in this) a receiver be appointed, and the injunction, etc., entered. This is the whole scope and purpose of the rule confining the return to these two points, and it is strictly in accord with equity practice.

3. The next paragraph of the return objects because no security was required from complainant at the time the restraining order was issued. This, again, is in the nature of a review of the order of the judge granting the restraining order. By section 718, Rev. St. U. S. [U. S. Comp. St. 1901, p. 580], "such an order may be granted with or without security at the discretion of the court or judge."

4. The fourth paragraph of the return raises the question that the trustee, W. D. Melton, is an indispensable party to the bill, even although making him so would oust the jurisdiction. The return goes farther; it avers that he is the only party who can file the bill for the foreclosure of the chattel mortgage set out in the bill. With regard to the character of the complainant and the objection to the filing of the bill by the cestui que trust and not the trustee, the point was made and distinctly ruled by the supreme court in *Grant v. Insurance Co.*, 121 U. S. 105, 7 Sup. Ct. 841, 30 L. Ed. 905. In that case the cestui que trust under trust deeds securing payment of money (a form of mortgage) filed a bill to enforce them in his own name. Objection was taken of the same character as this now set up, and the court overruled the objection, holding the practice proper. These were trust deeds of real estate. With regard to the position that W. D. Melton is an indispensable party, it will be noted that, although Mr. Melton is called a trustee, he is in fact the agent—the alter ego—of the H. B. Clafin Company. He represents no one else. He is responsible to no one else. He has no other interest in his charge. It was the money and the goods of the H. B. Clafin Company which were the consideration of the mortgage. So when the H. B. Clafin Company intervened it was the intervention of a principal to enforce a contract made with its agent. These proceedings were inaugurated by him, and the bill is sustained by his jurat. If any of his rights are involved, he would be precluded from hereafter setting them up. But he is a proper party to the bill, and at this stage the amendment can be made of course. Let the bill be amended, making William D. Melton, trustee, a party defendant.

5. The next objection is that the complainant has a plain, adequate, and complete remedy at law. The jurisdiction of the court of equity over foreclosure of mortgages is so well established that it needs neither authority nor argument to sustain it. *Scott v. Neely*, 140 U. S. 113, 11 Sup. Ct. 712, 35 L. Ed. 358. Besides this, in order to ascertain the amount due to the complainant in this case, an ac-

count must be taken as to the several payments made from day to day, and this itself is a ground of equity jurisdiction. The equity jurisdiction of the courts of the United States depends on the principles of general equity, and cannot be affected by any local remedy, unless that remedy has been adopted by the courts of the United States. *Fitch v. Creighton*, 24 How. 159, 16 L. Ed. 596. The defense of an adequate remedy at law means adequate remedy under the common law as it existed in 1789, and not to state statutory remedies. *Dodge v. Woolsey*, 18 How. 331, 15 L. Ed. 401; *Railroad Co. v. Elliott (C. C.)* 56 Fed. 773. It is true that complainant had another remedy. It held a mortgage of chattels, and claimed that the condition was broken. If so, it had the right to enter, take possession, and sell the chattels, accounting for any surplus that may remain. But this course was full of difficulty. The amount due was contested. Its establishment was a work of time, necessitating a trial. Very wisely it did not take this speedy and drastic course. It came into this court, where all the facts could be explained, the account be taken, and exact justice be done.

6. The last paragraph of the return goes more into the merits of complainant's demand. It avers that the mortgage was executed to secure moneys advanced to carry out a composition with the creditors of defendant at 50 cents on the dollar, in which composition the complainant had taken part, and to which it had assented, and, further, to secure all subsequent purchases by defendant from complainant; that from the net proceeds of sales, conducted under the supervision of complainant's agents, the money claim of complainant was reduced to \$789.13, and that defendant tendered that sum to complainant, which tender was refused, and so the mortgage is satisfied. The transaction between complainant and defendant, when negotiations were first opened and carried out, is told by Messrs. Melton and Nelson, who were specially authorized by defendant to enter upon and carry out this negotiation. The statement of these gentlemen varies entirely from the position now taken by defendant. They say: That the H. B. Clafin Company agreed to advance enough cash to purchase the outstanding claims against the defendant, and did in fact furnish the money. That with this money they approached the creditors individually, and negotiated with each creditor separately. That they made no general offer. They purchased the claims at varying discounts,—some as low as 30 per cent., others as high as 100 per cent.,—in every case taking an assignment of the claim, which was deposited with complainant as collateral. That on their return to Columbia they reported all this to defendant, and that he confirmed and approved their action. That defendant was informed that the H. B. Clafin Company debt was not compromised, but that that was to be paid in full, and to be secured by the mortgage. Defendant, on oath, denies this. It is true that the evidence now before the court is by affidavit,—the most unsatisfactory mode of proving anything. But deciding now upon affidavits, and for the purposes of this motion only, no other conclusion can be reached than that the account given by Messrs. Nelson and Melton is correct, and that the defendant's memory is at fault. The debt due to

complainant when this bill was filed was \$9,311.35, to which, as by the terms of the mortgage, attorney's fees must be added.

This brings us to the questions now before the court, shall a temporary receiver be appointed, and shall the injunction be continued? The affirmative to both of these questions depends somewhat upon the solvency of the defendant. His entire property is in the stock of goods. What is its value? Here again a conclusion must be reached upon the uncertain results of affidavits. Both sides produce them and they are irreconcilable. Those for the defendant say that the stock of goods is in excellent condition, and is worth between \$25,000 and \$30,000. Those for the complainant represent the stock as much broken up, worn, and much of it unsalable, estimating its value at about \$9,000. By other affidavits it appears that there are outstanding claims against Furtick, in judgment or in suit or in hands of attorneys for collection, about \$2,000. Although it seems that the preponderance of so much of the evidence as can be gathered from these affidavits is in favor of those of the complainant, it would not be satisfactory to rest on this alone. But by the terms of this mortgage complainant was placed in a supervisory position over this stock of goods. It was put actually in possession by Mr. Melton as its agent, appointed a cashier to remain in the store, and supervise the sales to the extent of ascertaining and receiving all the cash, except such as was needed for daily current expenses and a reasonable support of defendant. By operation of law, upon breach of any of the covenants of the mortgage the complainant was entitled to the possession of the stock. Whether there was a breach of the condition of the mortgage will depend upon the amount of the debt due thereunder. Defendant claims that nothing is due except the sum tendered. This must be ascertained and determined when the case is ripe for a hearing. In the meantime both parties assert a right of possession. Under these circumstances, without passing on these conflicting claims, it becomes the duty of the court to hold possession in the interests of both sides. To this end a receiver will be appointed.

Let both sides furnish the court with the names of persons competent to be receiver, and from them a selection will be made. In the meantime matters will remain as they now are, and the injunction will be continued until the further order of this court.

SPRIGG v. COMMONWEALTH TITLE INS. & TRUST CO.

(Circuit Court, E. D. Pennsylvania. December 20, 1902.)

No. 41.

1. CONSTRUCTIVE FRAUD—LIABILITY—IMPLIED REPRESENTATIONS IN LETTER.

A letter written by a trust company, copied from a draft prepared by counsel for the firm to which the letter was addressed, by which the company agreed to hold certain bonds of a corporation therein described, in trust for such firm, and which contained certain statements respecting such bonds, construed, and held not to constitute a representation that the bonds were valid, which rendered the company liable for deceit in case

they were not valid, where all the specific statements made were true, and there was nothing in the letter calling for any statement as to the validity of the bonds, and it was admitted that it was signed in good faith and without intent to deceive.

On Motion to Strike Off Judgment of Nonsuit.

Thomas Leaming, for plaintiff.

I. H. Mirkil and F. Carroll Brewster, Jr., for defendant.

DALLAS, Circuit Judge. The plaintiff's statement of claim, as originally filed, did not disclose what particular wrong the defendant was supposed to have committed. It alleged certain facts, but did not aver the legal effect intended to be ascribed to them. It did not appear from it whether the cause of action declared upon was deceit or was negligence, or whether the design of the pleader was to assert a right of recovery on both of these grounds. I did not doubt that both could, if desired, be included in a single suit *ex delicto*; but I suggested upon the trial that the statement should, perhaps, be more explicit upon the point I have mentioned, and thereupon the plaintiff moved for leave to amend. The defendant objected, and the court postponed consideration of the question thus raised until the motion to strike off the judgment of nonsuit should be heard. Both of these motions have since been argued, and are now for decision.

I am of opinion that the "amended statement of claim," a copy whereof is annexed to the brief submitted on behalf of the plaintiff, should be received; and accordingly, and in pursuance of the understanding between the court and counsel when the case was on trial, it will now be filed *nunc pro tunc*, with like effect as if it had been filed by leave of court prior to the entry of nonsuit.

The amended statement is, as plaintiff's counsel claims, and I think correctly, "to the effect that the defendant is liable to the plaintiff for writing a letter stating that it held valid bonds, whereas it did not do so"; and hence it appears that the wrongful act averred is the making of a statement which was not true, and that consequently this is an action of deceit. It is not a case of negligence, in the sense in which that word is ordinarily used to denote the specific wrong which is committed where any duty to exercise care is violated; and therefore such allegations of negligence as the declaration contains are not material, except as they may be pertinent to the question actually presented, which is, was any statement made in the letter which has been adverted to which entitles the plaintiff to recover for the loss which he says was thereby occasioned? This is the letter:

"Philadelphia, April 29th, 1893.

"Messrs. Rice Brothers, Providence, R. I.—Gentlemen: We are in receipt of an order from the Standard Coal and Timber Co., of West Virginia, instructing us to hold in trust for you one hundred first mortgage \$1,000 bonds of said company, the same being part of an issue of 1,000 bonds, \$1,000,000, all of which are equally secured by a first mortgage or deed of trust dated May 2nd, 1892, made to the Commonwealth Title Insurance and Trust Company of Phila. as trustee by the said Standard Coal and Timber Company of West Virginia, covering 204,000 acres of mineral and timber lands located in McDowell county, in said state of West Virginia. The company is incorporated

under the laws of the state of West Virginia, and the bonds are secured by the first mortgage or deed of trust now held by us as trustee. Said mortgage or deed of trust, together with certified abstract of title, opinions as to the value of property covered by said mortgage or deed of trust, maps, surveys, and other papers relating to the same, have been carefully examined and approved by us, and are now in our possession. We will hold the one hundred (100) bonds subject to your order.

"Respectfully yours,

A. A. Stull, Treas."

This letter was copied from a draft which had been written by the counsel of the firm to which it was addressed, and, as will be observed, it referred to a certain order, which order is as follows:

"A. A. Stull, Esq., Secty. Commonwealth Title, Insurance & Trust Company, Philadelphia, Pa.—Dear Sir: You will please hold in trust or deliver to the order of Rice Brothers, lumber dealers of Providence, R. I., one hundred (100) first mortgage one thousand dollar (\$1,000) bonds of the Standard Coal and Timber Company, in accordance with the terms of mortgage or trust deed held by you to secure said bonds.

"Respectfully yours,

Standard Coal and Timber Company,
"By O. C. Cokefair, Asst. Secty."

To make the statement of the circumstances under which the defendant signed the letter complained of sufficiently complete, it is necessary only to add that the draft of it was brought to the trust company by a person selected by the gentleman who had prepared it. It was not signed with intent to deceive. This is admitted, and, upon the proofs, could not be denied. But it is insisted that it contained statements of fact which were untrue, and that for their untruthfulness the defendant, though guiltless of conscious falsehood, was, by reason of the circumstances of the case, legally responsible. This contention cannot be sustained. The draft of letter was virtually a communication of inquiry, and its signature by the trust company was coupled with no duty upon its part but to see to it that, by the statements which it contained, the inquiries which it impliedly put were not untruly answered, either with knowledge of the untruthfulness of the matters stated, or in culpable ignorance of their falsity. *Pol. Torts*, p. 355; *Iron Works v. Barber*, 106 Pa. 125, 51 Am. Rep. 508. This duty was not violated. The statement that the defendant was in receipt of the order mentioned in the letter was true, as was also the designation of the bonds to which it referred as being a part of those which were secured by the coal and timber company's mortgage. It is equally true that the company was incorporated as stated, and that the mortgage and other papers had, as a matter of fact, been examined and approved by the trust company, and were then in its possession. Apart from its last sentence, which is reserved for separate consideration, it seems to me, therefore, to be perfectly clear that the letter was faultless. It did, indeed, describe the bonds in question as being part of an issue of 1,000 bonds, whereas, technically speaking, the issuance of 1,000 bonds had not occurred. But it is to be remembered that the language of this letter was not that of the trust company, but of the persons to whom it was addressed, and I think it is manifest that the word "issue" was neither understood by the one, nor intended by the other, to be significant of anything beyond fixing the identity of the bonds, and this it correctly did. It is likewise evident that the

word "secured," as it occurs in the letter, is also merely descriptive, and does not import either a warranty or a representation that the security of the bonds was perfect in law or was adequate in fact. Neither can the statement that the mortgage and other papers had been examined and approved be regarded as equivalent to a positive assertion that the title upon which the mortgage rested was a good one, and, at most, it amounted to nothing more than an expression of opinion, for which, of course, the defendant could not be held responsible. There remains, however, the promise with which the letter concludes, viz., "We will hold the one hundred (100) bonds subject to your order;" and it is insisted that here, at least, there was a misrepresentation for which the defendant is liable, because, as is claimed, the promise so made was calculated to induce the belief that the bonds to which it related were in all respects valid bonds, whereas certain acts necessary to their perfection had not been performed. This insistence is not well founded, either in fact or in law. The draftsman of the letter, who apparently had some knowledge of the matter he was writing about, did not in any part of it indicate that he desired information upon any subject not expressly covered by its terms. If he had wished to be apprised whether all things requisite to the perfection of the bonds had been done, he certainly should have included in his draft some statement upon that subject which could fairly be said to have directed attention to it. But this was not done, and now the effort is made to charge the defendant with fraud by ascribing to the word "bond," as used, an effect which cannot for a moment be supposed to have been intended. It is, of course, possible to conceive of a case in which a person speaking of bonds might be understood as necessarily meaning valid bonds; but this is not such a case. These obligations had been executed by the obligors. It was perfectly natural, therefore, that the draftsman of the letter should refer to them as bonds; and the defendant had no reason to suspect that it was really his purpose (if it was) to obtain an assurance of their validity. The implied question was, "Will you hold the one hundred (100) bonds subject to our order?" The answer of the trust company was, "We will;" and they have done so. The promise respected the particular bonds to which the letter had previously referred, and, as there has been no breach of that promise, I am utterly at a loss to see how the defendant incurred any liability, enforceable either by an action of tort or of contract. It is not asserted that it was guilty of purposed deception, and, upon the undisputed facts, a finding by the jury that it had acted with recklessness equivalent to fraud could not possibly have been sustained. *Griswold v. Gebbie*, 126 Pa. 363, 17 Atl. 673, 12 Am. St. Rep. 878. As was said by Lord Bramwell in *Weir v. Bell*, 3 Exch. Div. 243, "There never can be a well-founded complaint of legal fraud, or of anything else, except where some duty is shown, and correlative right, and some violation of that duty and right;" and, applying the principle thus tersely expressed, the conclusion seems to be inevitable that the plaintiff in the present suit wholly failed to make out a case. Therefore his motion to strike off the judgment of nonsuit is denied.

FRIEDLY et al. v. GIDDINGS et al.

(Circuit Court, D. Vermont. December 9, 1902.)

1. GENERAL VERDICT—SPECIAL FINDING—NECESSITY.

The court instructed that, if defendants were actuated by malice, when, in executing a writ of attachment, they broke open the door of the engine room of plaintiff's mill, and stopped the machinery, and carried away the main belt, the jury might give exemplary damages. In reply to a question by the foreman, they were told that they might state, if finding for plaintiff, how much of their verdict was for actual and how much for exemplary damages. *Held*, that a general verdict would not be set aside for want of such statement, as it covered the issues, and whether the court should require more in order to simplify or eliminate questions rested in its discretion.

2. HARMLESS ERROR.

The action of the court in not insisting on the special finding, if prejudicial to either, was harmful to plaintiff, rather than defendant.

3. JUDGMENT NOTWITHSTANDING VERDICT.

Judgment could not be rendered for the defendant notwithstanding the verdict where the record showed that the issues joined were not immaterial.

4. INSTRUCTIONS—IMMATERIAL ISSUES.

In an action for damages by reason of defendants' conduct in executing a writ of attachment by breaking into plaintiff's mill, stopping the machinery, and carrying away the main belt, there was no evidence or claim that plaintiffs might have procured another belt. The court instructed that from what the court and jury knew such belts could not be got at stores and put on, and that defendants would be liable for damages caused by them in keeping the belt until it was replevied. *Held*, that this was merely illustrative of a part of the situation not in issue, and was immaterial, and not prejudicial.

5. FIXTURES—MACHINERY—MAIN BELT.

According to the law of Vermont, the main belt of a steam marble mill, connecting the drive wheel with the main shafting, and furnishing the motive power, is a part of the realty.

6. WRONGFUL ATTACHMENT—EXEMPLARY DAMAGES.

Where operation of plaintiff's marble mill and quarry, valued at \$100,000, together with personalty valued at \$40,000, free of incumbrance, was stopped by a sheriff and constable, in executing a writ of attachment, by breaking into the mill and carrying away the main belt, instead of securing a lien of record under V. S. §§ 1101, 1103, exemplary damages might be granted.

7. SAME—EXCESSIVE VERDICT.

A verdict for \$996 could not be deemed excessive, exemplary damages being allowable, and the actual injury being incapable of definite ascertainment.

8. FEDERAL COURTS—STATE LAWS.

A motion for an adjudication by the court that the cause of action arose from the willful and malicious act of the defendants, and that they ought to be confined in close jail, and for a certificate thereof upon the execution, according to V. S. § 1751, cannot prevail, as Rev. St. U. S. § 914 [U. S. Comp. St. 1901, p. 684], providing that the practice, pleadings, and forms and modes of procedure in civil causes other than those in equity and admiralty cases shall conform to those in the state courts, applies to those for procuring the judgment, and not to those subsequent thereto, and section 916 [page 684], entitling the party recovering a judg-

¶ 8. Conformity of practice in common-law actions to that of state court. see notes to *O'Connell v. Reed*, 5 C. C. A. 594; *Insurance Co. v. Hall*, 27 C. C. A. 392.

ment in a common-law cause to similar remedies upon it to those of the state "to reach the property of the judgment debtor," applies to property, and not to the person.

At Law.

Fred M. Butler and Thomas W. Moloney, for plaintiffs.
Orion M. Barber and James L. Martin, for defendants.

WHEELER, District Judge. The plaintiffs own a marble mill operated by steam, and a quarry connected with it; the realty being worth upwards of \$100,000, and the personalty upwards of \$40,000, clear of incumbrance. The defendant Giddings, as constable, had a writ of attachment of \$12,000 against one of them. He took possession of the mill, nailed up the doors, and left the plaintiffs' superintendent in charge as keeper. The superintendent sent a resignation as keeper to Giddings, and started up the mill. Giddings got the defendant Wilson, who was sheriff of the county, to assist him, and requested the superintendent to shut off steam and stop the machinery, so he could take off the main driving belt connecting the engine with the main shafting, which was refused; and the defendants broke open the engineroom door, shut off the steam, and stopped the machinery, and took off the main belt, and carried it away, which stopped the mill until the belt was replevied and brought back; and then the foundation of the engine was found to be disturbed, and had to be repaired, which further delayed the running of the mill. According to the plaintiffs' evidence, the steam was shut off too suddenly while the machinery was in full motion, and the continuing of the motion by momentum without the steam shook the engine and injured the foundation; but, according to the evidence of the defendants, the shutting off of the steam, however sudden, would not have that effect. There was no evidence or claim that the plaintiffs might have procured another main belt, and started up sooner, to save loss. The court held and instructed the jury that the main belt was a part of the realty, not attachable and removable as personalty, and that the defendants were liable for the damage; that, from what the court and jury knew, such belts could not be got at stores here and put on, and that the defendants would be liable for what damages was caused by them in taking and keeping it away till it was replevied and brought back by the plaintiffs; that, if shutting off the steam by the defendants injured the foundation of the engine so the mill had to be stopped to repair it, the defendants would be liable for the damage caused by that; and that, if the defendants were actuated by malice for oppression, the jury might give exemplary damages. As the jury was about to retire, the foreman asked if they should state how much was for actual and how much for exemplary damages, and they were directed that they might state the amount of each, if any, on the verdict. They returned a general verdict for \$996 damages, but did not state what part, if any, was for exemplary damages. The defendants have moved to set aside the verdict for want of a statement as to what were found as actual damages and what as exemplary, because the dam-

ages are excessive, because of the ruling involved, and for judgment notwithstanding the verdict.

It was the duty of the court to require a verdict that would cover all the issues in the case. This was done by the general verdict. Whether the court should require more in order to simplify or eliminate questions saved as to some part of the case was discretionary. *Hodge v. Town of Bennington*, 43 Vt. 450. The special finding might have obviated questions as to exemplary damages saved by the defendants, but could not raise any not saved in respect to the general verdict. The exercise of the discretion in not insisting upon the special finding did not prejudice the defendants, but rather the plaintiffs, if either.

Judgment could not be rendered for the defendants notwithstanding the verdict here, for the issues were not joined upon the process, and were not immaterial. *Gage v. Barnes*, 11 Vt. 195. It is founded on the record, and not on evidence. *Cobb v. Cowdery*, 40 Vt. 27, 94 Am. Dec. 370. The record shows material issues to be tried, and not a right to judgment without trial.

The remark of the court about knowledge of procuring belts was illustrative merely of a part of the situation not in question, and was wholly immaterial.

The most important question is whether the main belt was realty or personalty; for, if it was personalty that could be taken away on the attachment, the verdict ought not to stand as it is. That the belt which connected the drive wheel with the main shafting was a part of the realty seems to be well settled by the law of the state, which is a rule of property, and must govern here in this respect. *Harris v. Haynes*, 34 Vt. 220, and cases therein referred to. The court there repeated with approval what it had said before about main shafting in such an establishment,—that it “was a constituent part of the mill, on the ground that the shafting was necessary to communicate the motive power to the machinery, and should be regarded as much a part of the mill as a water wheel would be if water applied by means of it furnished the motive power of the mill”; and, as to the things there in question, “we are of opinion that the engine and boilers, the arch mouth and grate, and the shafting and pulleys should be regarded as fixtures and parcel of the realty.” This belt took the power from the engine to the main shafting, and was as much a part of the machinery of the power as any of the appliances there mentioned.

The damages found go beyond what could be computed in dollars and cents from any evidence in the case. But the stoppage of such an establishment producing marble through various stages of manufacture for sale and shipment would involve injuries not capable of definite proof or estimate. The evidence showed clearly, from the admissions of the defendants themselves on cross-examination and otherwise, that the belt was removed for the purpose of stopping the mill and harassing the plaintiffs, when, by the laws of the state, at slight expense, a valid and adequate lien could have been created by record upon all the property without disturbing it. V. S. §§ 1101, 1103. Such wantonness was properly subject to exemplary dam-

ages, in the finding of which the jury would not be limited to those actually proved. *Earl v. Tupper*, 45 Vt. 275; *Hoadley v. Watson*, Id. 289, 12 Am. Rep. 197. The amount of such damages is so far within the judgment and discretion of the jury in view of the conduct of the party liable to them that it cannot be justly said that here they got outside their province.

The plaintiffs have moved for an adjudication by the court that the cause of action arose from the willful and malicious act of the defendants, and that they ought to be confined in close jail, and for a certificate thereof upon the execution, according to the statutes of the state (V. S. § 1751). The statute of the United States providing that the practice, pleadings, and forms and modes of procedure in civil causes other than those in equity and admiralty cases shall conform to those in the state courts, applies to those for procuring the judgment, and not to those subsequent (Rev. St. U. S. § 914 [U. S. Comp. St. 1901, p. 684]; *Ex parte Fisk*, 113 U. S. 713, 5 Sup. Ct. 724, 28 L. Ed. 1117); and that entitling the party recovering a judgment in a common-law cause to similar remedies upon it to those of the state "to reach the property of the judgment debtor" applies to property, and not to the person (Rev. St. § 916 [U. S. Comp. St. 1901, p. 684]). This motion therefore cannot prevail.

Motions overruled.

In re REMINGTON AUTOMOBILE & MOTOR CO.

(District Court, N. D. New York. December 26, 1902.)

1. CORPORATIONS—LIABILITY OF STOCKHOLDERS—ENFORCEMENT—INJUNCTION.

Creditors of an insolvent New Jersey corporation, who claim to have causes of action against certain stockholders by virtue of Laws N. J. 1896, c. 185, §§ 21, 48, 49, which, if the insolvency had not intervened, could only have been enforced by a creditors' bill after a judgment at law had been obtained against the corporation, execution issued, and returned unsatisfied, ought not to be restrained from prosecuting their claims against the corporation to judgment after proceedings in bankruptcy begun, but before adjudication, it being uncertain whether the trustee in bankruptcy, when appointed, could enforce the liability of the stockholders until the creditors had reduced their claims to judgments; but proceedings on the judgments will be enjoined, and only one proceeding allowed for the benefit of all, with the trustee a party thereto.

This is a motion to make permanent an injunction granted herein on the 19th day of November, 1902, and through which it is sought to restrain the creditors of the above-named corporation from commencing or prosecuting any action against said corporation, or entering any judgment against same. The alleged bankrupt is a corporation organized under the laws of the state of New Jersey, but has property and has been doing business in the state of New York.

Geo. E. Dennison, for petitioning creditors.

J. H. Grant, C. G. Irish, and John F. Nash, for certain creditors.

¶ 1. Stockholder's liability to creditors in equity, see notes to *Rickerson Roller-Mill Co. v. Farrell Foundry & M. Co.*, 23 C. C. A. 315; *Scott v. Latimer*, 33 C. C. A. 23.

RAY, District Judge. The general corporation law of the state of New Jersey, being chapter 185, Laws 1896, by sections 48 and 49 provides as follows:

"Nothing but money shall be considered as payment of any part of the capital stock of any corporation organized under this act, except as herein-after provided in case of the purchase of property, and no loan of money shall be made to a stockholder or officer thereof; and if any such loan be made the officers who make it, or assent thereto, shall be jointly and severally liable, to the extent of such loan and interest, for all the debts of the corporation until the repayment of the sum so loaned."

"Any corporation formed under this act may purchase mines, manufactories or other property necessary for its business, or the stock of any company or companies owning, mining, manufacturing or producing materials, or other property necessary for its business, and issue stock to the amount of the value thereof in payment therefor, and the stock so issued shall be full-paid stock and not liable to any further call, neither shall the holder thereof be liable for any further payment under any of the provisions of this act; and in the absence of actual fraud in the transaction, the judgment of the directors as to the value of the property purchased shall be conclusive; and in all statements and reports of the corporation to be published or filed this stock shall not be stated or reported as being issued for cash paid to the corporation, but shall be reported in this respect according to the fact."

Section 21 of such act provides as follows:

"Where the whole capital of a corporation shall not have been paid in, and the capital paid shall be insufficient to satisfy its debts and obligations, each stockholder shall be bound to pay on each share held by him the sum necessary to complete the amount of such share, as fixed by the charter of the corporation, or such proportion of that sum as shall be required to satisfy such debts and obligations."

The creditors claim that sections 48 and 49 have been violated, and that they have causes of action arising thereunder and under section 21 of the act against certain stockholders, which can be enforced only after judgment and the return of executions unsatisfied. The brief of the counsel for the petitioning creditors says the claim is "that property tangible and intangible (i. e., supposed good will or a business name) was bought at a fictitious price, and stock issued for it, which by some contrivance went into the treasury of the company, and was sold by the company to the stockholders sought to be sued for much less than par." He then denies that causes of action are given by any statute, conceding the facts stated, and further alleges that, if any such rights of action exist, the same are in the company, and will pass to and may be enforced by the trustee or trustees of the alleged bankrupt, when appointed, for the benefit of all the creditors, and that, therefore, the creditors should not be permitted to prosecute their actions to judgment as a basis for enforcing the alleged liability of the officers who have violated the sections quoted.

Section 68 of the act provides:

"Property, franchises, etc., of insolvent corporation vests in receiver upon appointment.—All of the real and personal property of an insolvent corporation, wheresoever situated, and all its franchises, rights, privileges and effects shall, upon the appointment of a receiver, forthwith vest in him, and the corporation shall be divested of the title thereto."

From the papers before it, this court understands the claim of the creditors to be: (1) That the whole capital was not paid in, be-

cause of noncompliance with sections 48 and 49, above quoted; (2) that the capital paid in is insufficient to satisfy the debts and obligations of the corporation; and therefore (3) each stockholder is bound to pay on each share held by him the sum necessary to complete the amount of such share as fixed by the charter of the corporation, or such proportion of that sum as shall be required to satisfy such debts and obligations. If this be true (assuming that insolvency had not intervened), a creditor may file a bill to enforce the liability created by the violation of the statute. But he can do this only after he has exhausted his remedies at law by judgment issue of execution and its return unsatisfied. And he must sue in behalf of all the creditors of the corporation, and not for himself alone. The corporation must be made a party; and all the property and assets of the corporation must be brought into the suit, and put in course of administration. The proceedings are in the nature of an equitable accounting. *Bickley v. Schlag*, 46 N. J. Eq. 533, 20 Atl. 250; *Wetherbee v. Baker*, 35 N. J. Eq. 507. When shares of stock were issued at a very excessive valuation, the transaction was held to be dishonest, and it was held that the shares were not fully paid. *Heberd v. Cattle Co.*, 55 N. J. Eq. 18, 36 Atl. 122. Some of the creditors of this alleged bankrupt corporation are now seeking to put their respective claims in judgment, issue execution, and thus place themselves in a position to bring an action in equity of the nature and for the purpose mentioned. If this preliminary action be necessary when bankruptcy has intervened, the injunction should not be made permanent or continued; for, if such a liability exists, and it can be enforced only by a creditor with judgment and execution returned unsatisfied, or by the trustee, when appointed, after a creditor or creditors have put themselves in this position, then to grant or make permanent this injunction will be to deprive the creditors of their rights. Is this liability an asset of the corporation, and, if so, will it pass to the trustee when appointed, and may he enforce it for the benefit of all? Will the proof of the insolvency of the corporation and the adjudication of its bankruptcy, followed by the proof in due course of the claims of creditors, be a substitute for judgment against the corporation and execution returned unsatisfied? If so, then action by creditors against the stockholders of the corporation may be unnecessary. But suppose the trustees, when appointed, should refuse to bring the action, must the creditors lose their rights to proceed against the stockholders which they might should they be denied the right to put their claims against the corporation into judgment? Under this statute the courts of New Jersey hold that when the corporation is insolvent, and its business is ended, the subscribers for or holders of its unpaid stock are assessable for only so much of what is unpaid on the stock as will satisfy the claims of corporate creditors and meet the expenses of winding up its affairs. An order for such an assessment may be made by the court of chancery in the suit wherein the corporation was adjudged to be insolvent, and, when so made, its propriety cannot be questioned in suits brought against the stockholders for its enforcement. *Cumberland Lumber Co. v. Clinton Hill Lumber Mfg. Co.*, 57 N. J. Eq. 627, 42 Atl. 585. See.

also, *Barkalow v. Totten*, 53 N. J. Eq. 573, 32 Atl. 2; *Hood v. McNaughton*, 54 N. J. Law, 425, 24 Atl. 497. The liability of the stockholders of this corporation, if any, under section 21 of the act, is contractual, one assumed by subscribing to the stock, and not a mere personal liability of the stockholder for the debts of the corporation created only by the statute of the state of the corporation's domicile. It is, therefore, enforceable in the state of New York. *Stoddard v. Lum*, 159 N. Y. 265-272, 53 N. E. 1108, 45 L. R. A. 551, 70 Am. St. Rep. 541; *Dayton v. Borst*, 31 N. Y. 435; *Cochran v. Wiechers*, 119 N. Y. 399, 23 N. E. 803, 7 L. R. A. 553; *Flash v. Conn*, 109 U. S. 371, 3 Sup. Ct. 263, 27 L. Ed. 966; *Richmond v. Irons*, 121 U. S. 27, 7 Sup. Ct. 788, 30 L. Ed. 864; *Sanger v. Upton*, 91 U. S. 60, 23 L. Ed. 220. In *Sanger v. Upton*, 91 U. S. 56, 23 L. Ed. 220, it was held that an assignee in bankruptcy (old law) might recover of the stockholders of an insolvent corporation adjudged a bankrupt the amount of their unpaid subscriptions; and the bankruptcy court made an order that the amount unpaid on the capital stock of the corporation should be paid to the assignee on or before a certain day, and in default thereof that the assignee proceed to collect the same. Notice to the stockholders of such order was given, and then suit was brought by the assignee, and it was held that the court had power to make the order, and that the action could be maintained. The supreme court of the United States has held:

"The amount of the unpaid subscriptions to the stock of the corporation is a trust fund for the payment of its debts. It is a substitute for the personal liability which subsists in private copartnerships. When debts are incurred, a contract arises with the creditors that it shall not be withdrawn or applied otherwise than upon their demands until such demands are satisfied. The creditors have a lien upon it in equity. If diverted, they may follow it as far as it can be traced, and subject it to the payment of their claims, except as against holders who have taken it bona fide for a valuable consideration, and without notice. It is publicly pledged to those who deal with the corporation for their security. Unpaid stock is as much a part of this pledge, and as much a part of the assets of the company, as the cash which has been paid in upon it. Creditors have the same right to look to it as to anything else, and the same right to insist upon its payment as upon the payment of any other debt due to the company. As regards creditors, there is no distinction between such a demand and any other asset which may form a part of the property and effects of the corporation." *Sanger v. Upton*, 91 U. S. 60, 61, 23 L. Ed. 220. See cases there cited.

The New Jersey statute may limit the liability of the stockholders, but it does not destroy it, or change its nature, which is contractual. It seems plain that when the adjudication is made in this case, and a trustee is appointed, the court may direct him to proceed against the stockholders, and enforce any liability for nonpaid subscriptions to the stock of this corporation. He will be subject to the order of the court. But it does not follow, and is by no means clear, that this may be done until the creditors have established their claims by reducing them to judgments. In *Bank v. Francklyn*, 120 U. S. 747, 7 Sup. Ct. 757, 30 L. Ed. 825, it is held:

"When the statutes of the state which creates a corporation, making the stockholders liable for the corporate debts, provide a special remedy, the liability of a stockholder can be enforced in no other manner in a court of the United States."

It was accordingly held that a "creditor of a Rhode Island corporation cannot bring an action at law against the executor of a stockholder in the circuit court of the United States in New York without having obtained a judgment against the corporation, even if the corporation has been adjudged bankrupt." In *Shellington v. Howland*, 53 N. Y. 371, the creditor seeking to reduce his claim against the corporation (adjudged a bankrupt) to judgment was restrained from the prosecution of his action by the United States court. The New York statute provided that a creditor of the corporation seeking to enforce a liability for his claim against a stockholder first must have reduced it to judgment, and followed this by the return of an execution unsatisfied. Held that, whatever judicial proceedings were required by the statute as a condition precedent to defendant's liability, the taking of such proceedings having been rendered impossible by the paramount law of the United States, put in operation by him (the stockholder), a compliance with the condition was excused. There are cases both ways on the question whether, when the corporation has been adjudged a bankrupt, and a dissolution has in this way been brought about, the remedy against the corporation need not be first exhausted. See 1 *Cook, Stock, Stockh. & Corp. Law*, § 200, page 251, and cases cited note 2. See opinion *Stoddard v. Lum*, 159 N. Y. 272-273, 53 N. E. 1108, 45 L. R. A. 551, 70 Am. St. Rep. 541, and consult *Tube Works Co. v. Ballou*, 146 U. S. 317, 13 Sup. Ct. 165, 36 L. Ed. 1070. So long as uncertainty exists as to the effect of enjoining these creditors from prosecuting their claims against this corporation to judgment, the wise course is to permit the creditors to bring their actions and prosecute them to judgment; otherwise the creditors may be deprived of a valuable part of the assets of the corporation. All proceedings on such judgments will be enjoined, however, and, if a creditor's action to recover the unpaid subscriptions is found necessary, only one will be permitted, as that must be brought for the benefit of all, and the trustee will be a party, and the rights of all protected.

The adjudication in bankruptcy and appointment of a trustee (in whom all the property of the corporation is then vested) will be a substitute for execution returned unsatisfied. So ordered.

McNALLY v. FIELD.

(Circuit Court, D. Rhode Island. December 20, 1902.)

No. 2,662.

1. INTERNAL REVENUE—ADMINISTRATOR'S BOND—LIABILITY TO TAX—CONSTRUCTION OF STATUTE.

Act March 2, 1901 (31 Stat. 945 [U. S. Comp. St. 1901, p. 2304]), being an amendment of Act June 13, 1898 (30 Stat. 460 [U. S. Comp. St. 1901, p. 2284]), for the purpose, as shown in its title, of reducing taxation, provided: "Seven. Bond: For indemnifying any person or persons, firm or corporation who shall have become bound or engaged as surety for the payment of any sum of money, or for the due execution or performance of the duties of any office or position and to account for money received by virtue thereof, fifty cents." The original act had added to this pro-

vision, "all other bonds of any description except such as may be required in legal proceedings, not otherwise provided for in this schedule." *Held* that, in view of its purpose to reduce taxation, the amending act would be construed as referring only to bonds given to indemnify sureties, and would not cover the original bond of an administrator, which, by ruling of the commissioner of internal revenue, would have been exempted under the original act as a bond required in a legal proceeding.

2. SAME—DOUBTFUL CONSTITUTIONAL POWER.

The constitutional power of congress to impose a tax on an administrator's bond running to a state court having probate jurisdiction being questionable, that construction of the statute will be adopted which will relieve it from the imputation of an exercise of a doubtful power.

3. STATUTE IMPOSING TAX—AMBIGUITY—CONSTRUCTION IN FAVOR OF TAXPAYER.

Where a statute imposing a tax is susceptible of two constructions, and the legislative intent is in doubt, the doubt should, as a rule, be resolved in favor of the taxpayer.

Wm. M. P. Bowen, for petitioner.
Chas. A. Wilson, U. S. Dist. Atty.

COLT, Circuit Judge. The question presented on this petition for a writ of mandamus is whether administrators' bonds are within the following paragraph of the act of March 2, 1901 (31 Stat. 945 [U. S. Comp. St. 1901, p. 2304]):

"Seven. Bond: For indemnifying any person or persons, firm, or corporation who shall have become bound or engaged as surety for the payment of any sum of money, or for the due execution or performance of the duties of any office or position, and to account for money received by virtue thereof, fifty cents."

The contention of the petitioner is that this paragraph is limited to bonds for indemnifying a surety upon bonds for the payment of any sum of money, or upon bonds for the due execution and performance of the duties of any office or position, and, consequently, that it does not cover original bonds such as are given by administrators. On the other hand, the contention of the government is that the first part of the paragraph covers bonds for indemnifying a surety, and that the latter part has reference to original bonds given for the due execution and performance of the duties of any office or position, and therefore includes administrators' bonds.

The arguments of counsel on one side and on the other fail to make the meaning of this paragraph plain. It is manifestly ambiguous upon its face, and may be interpreted either way.

We have presented, then, for our determination the proper interpretation of a statute capable of two constructions, and the question is whether the court should adopt the construction of the petitioner or the construction of the government. In my opinion, the construction asked for by the government is open to such serious objections that it should not be followed.

This paragraph appeared originally in the act of June 13, 1898 (30 Stat. 460 [U. S. Comp. St. 1901, p. 2304]), in the following form:

"Bond: For indemnifying any person or persons, firm, or corporation who shall have become bound or engaged as surety for the payment of any sum of money, or for the due execution or performance of the duties of any office or position, and to account for money received by virtue thereof, and all other bonds of any description, except such as may be required in legal proceedings, not otherwise provided for in this schedule, fifty cents."

Under the above paragraph, the commissioner of internal revenue ruled that the bonds of "receivers, assignees, executors, administrators, and guardians," "for the faithful performance of the duties of their office or positions," were exempt, since they were bonds "required in legal proceedings," and so within the exception mentioned.

As the paragraph now stands under the act of March 2, 1901, the words, "and all other bonds of any description, except such as may be required in legal proceedings," have been eliminated. The commissioner has ruled, and the government now contends, that the repeal of the exception in the above clause operates to make the bonds of receivers, assignees, executors, administrators, and guardians taxable under this paragraph. It does not seem to me that such was the intention of congress.

The original act of June 13, 1898 [U. S. Comp. St. 1901, p. 2284], was the Spanish war revenue act. Its purpose was "to provide ways and means to meet war expenditures." The act of March 2, 1901, was amendatory to this act, and its purpose, as the title shows, was to "reduce taxation" under the original act. In the accomplishment of this purpose parts of the original act were repealed, including that portion of the paragraph to which we have referred. The position of the government involves the conclusion that, in an amendatory act to reduce taxation, by which the omnibus clause of the former act covering "all other bonds of any description," together with an exception, was repealed, congress intended by this repeal to impose a tax on the very class of bonds which were expressly excluded by the original act. It is manifest that congress did not intend to enlarge the scope of the original act. In that act congress evidently desired to tax all classes of bonds, but, on grounds of public policy or because such taxation might prove unconstitutional, it excluded bonds "required in legal proceedings." Under such circumstances it is not reasonable to conclude that it was the purpose of congress, in an act to reduce taxation, to change the policy which it has followed since the adoption of the war revenue act of 1862 (12 Stat. 481), and to declare its purpose to tax this class of bonds. Certainly a conclusion of this character should not be reached in the absence of a clear and unmistakable intention on the part of congress. Such a conclusion should rest on a stronger foundation than an interpretation of an ambiguous statute which leads to such a result.

But the position of the government is open to other objections. It is familiar law that congress has no power to tax the governmental instrumentalities of a state. It is the acknowledged right of a state to administer justice through its own courts, and to employ all necessary agencies for that purpose, unobstructed by the federal government. These subjects are therefore not within the taxing power of congress. It is at least questionable whether this prohibition does not extend to bonds required in legal proceedings, such as the bonds of administrators, executors, receivers, assignees, and guardians. These bonds would seem to form a necessary part of the machinery through which the state exercises its judicial power.

Courts of probate are a part of the judicial system of the different states. The municipal court of the city of Providence has probate

jurisdiction. The bond of an administrator runs to the probate court. These bonds are an indispensable part of the judicial system of the state in the exercise of its probate jurisdiction. An administrator may be considered an officer of the probate court. He is at all times subject to its orders and decrees. The power to tax an administrator's bond involves the power to obstruct the state in the exercise of one of its most important judicial functions. It is not necessary, however, to pass upon the constitutional power of congress to levy this tax. It is sufficient, for the purposes of this case, that such a power is questionable or the fair subject of doubt. The present controversy turns on the construction of an ambiguous statute, and the court will never so interpret a statute as to involve the exercise of a doubtful constitutional power, if it is open to any other reasonable interpretation. It may also be observed that a tax should not be imposed unless such purpose clearly appears. When a statute is susceptible of two constructions, and the intention of the legislature is in doubt, such doubt, as a rule, should be resolved in favor of the taxpayer.

It is true that the decision of the commissioner of internal revenue or of any department of the government, in construing a statute, is entitled to due consideration and much respect; but, giving the rulings of the commissioner such weight as they are entitled to upon the facts as they appear, they cannot be permitted to govern where the proposed construction of the statute is open to the serious objections arising in the case at bar.

Demurrer overruled, and petition granted.

McCLINTOCK et al. v. FONTAINE et al.

(Circuit Court, N. D. West Virginia. September 27, 1902.)

1. TENANTS IN COMMON—ADVANCEMENT OF TAXES—CONTRIBUTION.

One who, as trustee, owning an undivided half of certain land, pays taxes on the whole, is entitled, as a tenant in common, to contribution from the other owners, and therefore to a lien on the land for the amount advanced.

2. VENDOR—DEFENSE OF TITLE—CONTRIBUTION FROM VENDEE.

The owner of land, who conveyed, with covenants for quiet enjoyment and of warranty, an undivided portion thereof, having defended a suit involving all the land, without any notice from the grantee requiring him to so defend, was entitled to contribution for expenses incurred thereby.

3. EQUITY—JURISDICTION—MULTIPLICITY OF SUITS.

In a suit for partition a cross-bill was filed by one of the co-owners, asserting a lien for taxes paid and advanced on the land, and seeking contribution. It appeared that plaintiffs were entitled to contribution from the complainants in the cross-bill for expenses incurred in defending a suit involving the whole land. *Held*, that the two claims could be adjusted in the partition suit, and it was not necessary for plaintiffs to file a bill for contribution, or bring an action at law.

Exceptions to Master's Report.

Vinson & Thompson, for plaintiffs.
Henry M. Russell, for defendants.

JACKSON, District Judge. On the 19th day of September, 1893, Alexander McClintock and John McClintock, partners doing business as Alexander McClintock & Son, who are citizens and residents of the state of Kentucky, filed their bill of complaint against W. B. Fontaine and C. B. Fontaine, partners doing business as W. B. Fontaine & Bro., who are citizens and residents of the state of West Virginia, and P. B. Dobbins, trustee, and others, who are citizens and residents of the state of West Virginia, and the Bowman Lumber Company, a corporation created and existing under the laws of the state of Pennsylvania, and doing business in the state of West Virginia. The plaintiffs in the bill allege that they are the owners of one undivided one-half interest in and to a tract of land lying and being in Logan and Boone counties, W. Va., containing 30,018 acres, and that the other half of the same tract of land is owned by P. B. Dobbins, trustee. One of the objects of this suit is to have the land partitioned and divided between the plaintiffs in this case and the trustee, Dobbins. Various other reliefs are prayed for in the bill, which are unnecessary to refer to at this time. On the 14th day of January, 1902, Howard Hazlett, who is one of the trustees of the property involved in this suit, appointed in the place of P. B. Dobbins, deceased, filed his petition setting up the fact that he is one of the trustees of one-half of the real property mentioned and described in the cross-bill, claiming a lien for \$2,800.72 for taxes paid and advanced by him to the state of West Virginia. Upon this petition another order of reference was made to A. G. Patton, who was directed to ascertain the liens upon the real property mentioned and described in the cross-bill filed in this case, with their respective amounts and priorities, and also to consider and determine the claims made in the cross-bill of liens for taxes, and whether or not there are any offsets against the liens for taxes, and, further, to report the situation and condition of the said real property, with respect to making a partition of the same amongst its respective owners, and whether or not it is to the interest of the owners to have the same sold and the proceeds divided, or whether the property should be divided in kind. In pursuance to this order the master made and filed his report on the 21st day of October, 1901. To that report exceptions are taken by C. L. Talbott and John McClintock. This case is now heard upon those exceptions.

The first and second exceptions to the master's report, stating that the master erred in finding that Hazlett, the trustee, has a lien against the said land for taxes paid thereon (especially for the last payment of taxes, as shown in his report), and that the master erred in finding that Hazlett, the trustee, is entitled to cost, and sale of the said land to be made for the payment of the said taxes, are overruled, for the reason that the trustee was acting as the agent of the joint co-owners of the land with the plaintiffs in this action; and the payment of the taxes by him, as one of the owners of the land, gave him a lien against the owners of the other half, and, by reason of the fact that he had

advanced the money to the state of West Virginia, gave him a right of action for contribution against the plaintiffs in this action, who owed their proportion of the taxes. Hazlett, as a tenant in common, was protecting the land in the interest of all the owners of the property; and, if he has paid the entire taxes on the property, he is entitled to contribution from the other owners for the amount that he advanced for them, to relieve the property of the lien of the state of West Virginia for its taxes. Hazlett is therefore entitled to a lien upon the property for the amount that he advanced.

As to the third and fourth exceptions to the master's report, it would seem to be but equitable and just that Hazlett, the trustee, who represented the owners of one-half of the interest of the land in controversy in the King suit, should contribute to the defense of that suit. But it is equally true that, if McClintock had not defended the suit and prevailed in it, their title to the land might have been lost. It was not McClintock's duty to defend the suit, as to the part he conveyed to Dobbins, unless Hazlett, acting for himself and those he represented, gave notice to him of the fact of the existence of the suit, and required him to defend it. It was clearly the duty of Hazlett and those whom he represented to defend their title, and a failure to do so would not entitle them to an action against McClintock upon his warranty, unless it was clearly established that their title would not avail against the title of King, and not then until after their eviction. It is well settled that an eviction is necessary to a breach of the covenants for quiet enjoyment and of warranty. If Hazlett knew of the suit of King against their land, and failed and neglected to defend it, it was his duty, being in possession of the land under a deed from McClintock, to protect it. Rawle, Cov. § 131. In this case it appears that McClintock expended a large amount of money in defending the suit against King, which was for the benefit of his co-tenants as well as himself. This being so, it would seem that Hazlett and those whom he represented should share in the burdens of the defense. "A tenant in common, claiming an equality of benefit, must submit to an equality of burden." *Wilton v. Tazwell*, 86 Ill. 29; *Freem. Co-Ten.* §§ 174, 175. But it is claimed that, to secure a contribution from his co-tenants, McClintock should file his bill, or bring an action in assumpsit, to assert his claim. Ordinarily this would be so. But can it be said that where a court is dealing, as in this case, with the equities between the parties, McClintock should be turned over to his bill seeking contribution, or to his action at law, to recover the amount which he claims is due him for defending the suit? Hazlett, in his petition, seeks to charge the land with a large amount for taxes that he has advanced. The plaintiff McClintock claims that he ought to be reimbursed, as a set-off to the taxes, for the expenses that he incurred, to the extent that his co-tenants would be liable in defending their interest to the land in controversy. It would seem, under the circumstances of this case, the court, having before it the claim of Hazlett for the amount of money that he advanced in the discharge of the taxes against the land, that McClintock should have the right to have his claim adjusted and settled in this proceeding, in order to avoid a multiplicity of suits.

For the reasons assigned, the court is of the opinion that the third and fourth exceptions to the master's report should be sustained, and referred back to the master, to ascertain the amount that McClintock paid in defense of the title to the 30,018 acres of land, and also to ascertain what is a just and proper charge against that portion of the land that Hazlett and those whom he represented claim.

PATTERSON v. J. S. OGILVIE PUB. CO.

(Circuit Court, S. D. New York. November 21, 1902.)

1. COPYRIGHT—DEPOSITING COPIES—EVIDENCE.

Evidence in a suit for an infringement of a copyright held sufficient to show that the author had mailed two copies of the book addressed to the librarian of congress, notwithstanding the register of copyrights certified that he could not find any copies on file.

2. SAME—FILING COPY OF TITLE OF WORK—VARIANCE.

The copy of the title of a book filed to obtain a copyright was "The Captain of the Rajah. By Howard Patterson. Illustrated by Warren Sheppard. A thrilling and realistic sea story from a noted sailor's pen, and lavishly illustrated by the pencil of America's greatest marine artist." The title of the book published was "The Captain of the Rajah. A Story of the Sea, by Howard Patterson. Illustrated by Warren Sheppard." Held, that the author did not lose his copyright by reason of publishing the book with the shorter title.

3. SAME—RESIDENCE OR CITIZENSHIP OF AUTHOR.

In a suit for an infringement of a copyright, on the issue of whether the author was a citizen or resident of the United States at the time he applied for the copyright, the certificate from the librarian described him as of New York, and the author testified that he was at the time of the trial a resident of New York, and that he had mailed the two copies to the librarian of congress in New York more than 10 years before. Held, that this was sufficient proof of the author's residence, in the absence of any evidence to the contrary.

4. SAME—PLACE OF PRINTING—PROOF.

Complainant in a suit for an infringement of a copyright of a book printed in 1890 is not obliged to prove that it was printed from type set within the United States, or from plates made therefrom; Rev. St. § 4956 [U. S. Comp. St. 1901, p. 3407], being amended as to require such proof by an act passed March 3, 1891.

5. SAME—ABANDONMENT.

In a suit for an infringement of a copyright it appeared that the author had type set up, plates taken therefrom, and sheets to the amount of 2,000 impressions struck off, and some of these were bound, distributed, and sold. A judgment was rendered against him, execution issued, and the plates were levied on and sold to a third person. Held, that the author, as against a purchaser of the plates from the third person, had not abandoned his copyright of the book.

6. SAME—ESTOPPEL.

The author, as against such purchaser, was not estopped from enforcing his copyright rights.

7. SAME—LIMITATION.

Rev. St. § 4968 [U. S. Comp. St. 1901, p. 3416], limiting actions for forfeitures or penalties under the copyright laws, is not applicable to a suit for an injunction against and damages for an infringement of a copyright.

This cause comes on for hearing on bill, answer, and proofs. The suit is for injunction against and damages for infringing complainant's copyright.

Chas. H. Luscomb, for complainant.
A. W. Gleason, for defendant.

LACOMBE, Circuit Judge. The proofs support the averments of the bill that complainant is the author of a work of fiction, and that on June 12, 1890, before the day of publication of the book, he deposited in the office of the librarian of congress, United States of America, a printed copy of the title thereof. The book published by defendant is a copy of complainant's. The relevant facts may be conveniently presented in connection with the discussion of the points raised by defendant.

The register of copyrights, on February 17, 1902, certified that he had made search, and could not find any copies of the book on file. The complainant testified that he personally inclosed two copies of his book in a package addressed to the librarian of congress, and deposited the same in the mail; and that this was in June, 1890,—a considerable time before the publication of the book. This is the evidence of the complainant, and it is not corroborated; but there is nothing in his testimony, direct or cross, which casts suspicion on his good faith, and there seems to be no reason for disbelieving his statement as to the mailing. The books were printed, and there was no reason at all why he should not have mailed them as he said he did. The certificate of the librarian of congress is that complainant "deposited in this office the title of a book, the title or description of which is in the following words to wit: "The Captain of the Rajah. By Howard Patterson. Illustrated by Warren Sheppard. A thrilling and realistic sea story from a noted sailor's pen, and lavishly illustrated by the pencil of America's greatest marine artist." Defendant contends that complainant has lost the protection of the statute, because he published the book with the short title: "The Captain of the Rajah. A Story of the Sea, by Howard Patterson. Illustrated by Warren Sheppard." A similar proposition was considered and held unsound in *Daly v. Webster*, 4 C. C. A. 10, 56 Fed. 483.

It is further contended that the copyright is void because it is not affirmatively shown that complainant, when he applied for copyright, was "a citizen of the United States, or a resident therein." The certificate from the librarian describes him as "of New York," and he testifies that he is now resident here, and that he mailed the two copies June, 1890, in New York City. The evidence is slight, but, in the absence of any evidence to the contrary, would seem to be sufficient.

It is further objected that there is no testimony to show where the type was set, or where the plates were made, and counsel for defendant refers to section 4956, Rev. St. [U. S. Comp. St. 1901, p. 3407], which provides that the book "shall be printed from type set within the limits of the United States, or from plates made therefrom." The difficulty with this objection is that the book was copyrighted and printed in 1890, and the amendatory act which inserted in section 4956 [U. S. Comp. St. 1901, p. 3407] the words above quoted was not passed until March 3, 1891.

It is further contended that complainant is estopped because of abandonment. It appears that he had type set up, plates taken therefrom, and sheets to the amount of 2,000 impressions struck off. Some of these were bound up, and distributed to papers and periodicals for review, or sold. He became financially embarrassed, a judgment was entered against him, execution issued, and the sheets and plates were levied on and sold by the sheriff. Defendant purchased the plates from some one to whom they had passed from the purchaser at sheriff's sale. The copyright was not sold, and complainant has not lost his right to enforce it because he failed to prevent the sale of the plates. They were mere pieces of metal, which became the property of the purchaser, but gave him no right to publish the copyrighted work which could be printed from them. Complainant did not abandon his copyright by failing to buy them in, and is not estopped thereby from enforcing his statutory rights.

Finally, it is contended that complainant is barred by the statute of limitations (section 4968, Rev. St. [U. S. Comp. St. 1901, p. 3416]). That section provides that no action shall be maintained in any case of forfeiture or penalty under the copyright laws unless the same is commenced within two years after the cause of action has arisen. The defendant published in 1894, and this suit was begun in 1901, soon after the complainant learned of the publication. This suit, however, is not for a forfeiture or penalty, so the section does not apply. The complainant is clearly entitled to an injunction.

The only question remaining is as to the damages. The usual practice is to enter an interlocutory decree providing for an injunction and sending it to a master to take proof of damages or profits. Upon the return of the master's report a final decree disposes of the question of damages. Complainant apparently tried the case on the theory that he was to make proof of damages at this stage. The record does not entitle him to recover more than the nominal amount, six cents. Nevertheless, if he now elects to take an interlocutory decree, and is willing to pay the master's fees, he may have the opportunity to show, if he can, that he is entitled to recover substantial damages.

Complainant may take a final decree for injunction and six cents damages, or an interlocutory decree for injunction, with reference to a master.

In re CERTAIN LAND IN LAWRENCE.

(District Court, D. Massachusetts. October 22, 1902.)

No. 1,327

1. CONDEMNATION FOR POST OFFICE—LAND DEDICATED FOR A PARK—CONTEST—COMPENSATION.

Under the laws and decisions of Massachusetts, governing in a proceeding by the United States to condemn land in that state for a post office, a city in which land has been dedicated for use of its inhabitants as a public park cannot have compensation therefor, it having no legal estate in the land; but it may contest the taking on the ground that the public use as a post office is not superior to the public use as a park.

¶ 1. See Eminent Domain, vol. 18, Cent. Dig. § 219.

Henry P. Moulton, U. S. Atty., and William H. Garland, Asst. U. S. Atty.

John P. Sweeney and John P. Kane, for city of Lawrence.
James R. Dunbar and Stimson & Stockton, for Essex Co.

LOWELL, District Judge. This is a proceeding to take land for a post office in Lawrence. The Essex Company once owned the land, and has never conveyed it by deed. The city of Lawrence has filed an intervening petition, which sets out:

"First. That said land was by the former owner thereof dedicated to the inhabitants of the said city of Lawrence for use as a public park; that said dedication was accepted, and said land has been so used and enjoyed by the public under said dedication for a period of forty years and upwards; and that the city of Lawrence is now the owner in fee of said land. Second. That said land has been used by the public as a public park, and also as a means of access by paths across the same, adversely, continuously, and uninterruptedly, for a period of more than twenty years, and that the city of Lawrence has acquired title to said land by prescription, or at least has acquired a prescriptive right of way across said land."

For the purposes of the case, it is assumed that the evidence would show an uninterrupted public user for more than 20 years, and would also show the designation of the land as a park upon plans made more than 20 years ago by the Essex Company. There was no other positive act by the company, and no formal act by the city government.

This land is condemned, not by virtue of any paramount authority of the United States, but by virtue of authority delegated to the United States by the commonwealth of Massachusetts. Const. U. S. art. 1, § 8; Rev. Laws Mass. c. 1, § 7; *Burt v. Insurance Co.*, 106 Mass. 356, 8 Am. Rep. 339. It follows that these proceedings are governed by the laws of Massachusetts, and that the rights of the city to the land in question are determined by those laws. So far as applicable, the decisions of the Massachusetts supreme court control this court.

That a town may acquire a right of way by prescription was decided in *Deerfield v. Railroad*, 144 Mass. 325, 11 N. E. 105, and doubtless it may in appropriate case acquire a fee. See *City of Boston v. Richardson*, 105 Mass. 351, 357. But the cases cited show that rights thus acquired are altogether different from those asserted by the city of Lawrence in the case at bar. They are not public, but private to the city. See *Green v. Inhabitants of Chelsea*, 24 Pick. 71, 79. The interest of the city of Lawrence in the land in question, whatever it may be, is an interest for the use and benefit of the public, and not such a private interest as a municipality may have in real estate. *Oliver v. City of Worcester*, 102 Mass. 499, 3 Am. Rep. 485; *Proprietors of Mt. Hope Cemetery v. City of Boston*, 158 Mass. 509, 519, 33 N. E. 695, 35 Am. St. Rep. 515. A park is in that class of municipal property which includes highways and schoolhouses, not in the class which includes city halls. Counsel for the Essex Company has contended that property so held by the municipality is in the control of the state for the benefit of the public, and that, in the absence of express statute, the attorney general alone can maintain an action for the defense of the public rights. *Attorney General v. Abbott*, 154 Mass.

323, 28 N. E. 346, 13 L. R. A. 251. That case held, also, that the fee in land dedicated by an individual for a public park remains in the individual. It seems, then, that, whether the right to public use arises from dedication or prescription, there is no title in the municipality to easement or fee. "A town does not in such case own the land over which a way passes. Nor does it own the easement created by the construction of the way. That belongs to the public." *Inhabitants of Cheshire v. Adams & C. Reservoir Co.*, 119 Mass. 356, 357.

But in some cases a municipality is permitted to maintain suit by virtue of its interest and of the interest of its inhabitants in property held for the public benefit. In *Inhabitants of Springfield v. Connecticut River R. Co.*, 4 Cush. 63, a suit was maintained by a town to prevent interference by a railroad with a highway laid out in part by the county commissioners, and in part by the selectmen. The fee in the land was not in the town, and the use was public. In *Easthampton v. County Com'rs*, 154 Mass. 424, 28 N. E. 298, 13 L. R. A. 157, the town of Easthampton sought to prevent the county commissioners from laying out a highway over land belonging to the town, and used in connection with a schoolhouse. Whether the town of Easthampton had the fee in the land, or only an easement, does not appear. The court made no question that the town was a proper party to bring the suit, but held that the legislature had the right to provide that property taken for one public use should be applied to another, and that, in the absence of express statutory provision, the question whether it had done so or not was to be answered upon consideration of the relative importance and the necessities of the two uses, the extent of the harm to be done, and the circumstances of the particular case. Under the circumstances of the case before it, the supreme court held that the highway was validly laid out; but the opinion implies that, had the highway been laid out, not over the land used in connection with the schoolhouse, but through the schoolhouse itself, the decision might have been different. To the same effect is *City of Boston v. Inhabitants of Brookline*, 156 Mass. 172, 30 N. E. 611, where the city of Boston sought to prevent the town of Brookline from laying out a way over a strip of land in which the city of Boston had condemned, and paid for, an easement for the construction of a sewer. In the absence of express statutory provision, the question is one of reasonable interpretation of the legislature's general intent, as applied to the case before the court. If a municipality can thus maintain suit to prevent interference with property condemned for a public use, it can also maintain suit where the public use arises from dedication or prescription. While the cases cited decide or imply that the municipality can sometimes maintain suit to test the validity of a taking of land within its limits already devoted to one public use, yet they contain no implication that the municipality is ever to be compensated in money for the later taking. Thus, in *Boston & A. R. Co. v. City of Boston*, 140 Mass. 87, 89, 2 N. E. 943, speaking of highways and railroads, the court said, "The legislature has authority to grant either so as to interfere with a previous grant of the other, providing for compensation when private rights are impaired." In *Inhabitants of Mill-*

bury v. Blackstone Canal Co., 25 Mass. 473, no damages were allowed the town for interference with highways. See *Inhabitants of Cheshire v. Adams & C. Reservoir Co.*, *ubi supra*; *Browne v. Turner*, 176 Mass. 9, 13, 56 N. E. 969. In *Inhabitants of Millbury v. Blackstone Canal Co.* and in *Inhabitants of Cheshire v. Adams & C. Reservoir Co.*, where the plaintiff towns did not own the fee in the highways, it was intimated, indeed, that the result might have been different if the fee had been in the town. See, also, *Prince v. Crocker*, 166 Mass. 347, 362, 363, 44 N. E. 446, 32 L. R. A. 610. On the other hand, no compensation was allowed in *Easthampton v. County Com'rs*. Here it has been shown that the city of Lawrence has no legal estate in the land. Whatever may be the rule where the municipality has a legal estate, yet, in the want of such an estate, the municipality can intervene only to contest the taking, not to claim compensation for it. If the legislature authorizes the taking for one public use of land which is already subject to another public use, the land can be so taken without compensation. The legislature is the sufficient judge of the relative importance of the two uses. If there is no express legislative provision, the relative importance of the two uses is to be determined by the court. If the later use is deemed by the court, under all the circumstances, to be more important than the earlier, the land is taken for the later use without compensation for the loss of the earlier. If the earlier use is deemed the more important, the later is forbidden, and the earlier continues.

We come next to the application of these principles to the facts of this case. There is here no express provision of statute. I do not believe that the United States could, at its will, build this post office in the middle of the principal street of Lawrence, or across the main line of an important railroad. I do not think that the right of the public to prevent the first-mentioned taking can be vindicated only by the attorney general. I doubt if it can be laid down, without qualification, that the public use of a post office is in all places superior to the public use of a park. That it is so in the case at bar appears probable from what appeared incidentally at the argument, but the issue was not then raised, and cannot be determined without further hearing, if the city desires to be heard.

ANDREW D. MELOY & CO. v. DONNELLY et al.
(Circuit Court, D. Connecticut. December 30, 1902.)

No. 523.

1. CONSPIRACY—FRAUD—COMPLAINT.

A complaint for conspiracy alleged that defendants jointly confederated to fraudulently induce plaintiff to exchange stock for certain real estate belonging to one of the defendants; that three of the defendants, who ostensibly acted as plaintiff's agents, in fact represented the real estate owner, and fraudulently stated to plaintiff that the land was worth \$48,800, and that two other defendants were conservative appraisers, acquainted with the property, who would appraise the same; that such

defendants executed a written appraisal valuing the property at such sum, though it was not worth more than a third thereof, with intent to deceive and defraud plaintiff, and that representations of the owner as to a reason for selling were substantiated, defendants, ostensibly acting as plaintiff's agents, intending to induce plaintiff not to make an investigation of the value of the property, by reason whereof, plaintiff exchanged the stock for the property without such examination; and that the owner's agent received 600 shares thereof as his share of the profits of such conspiracy. *Held*, that the complaint was not demurrable, as against any of the defendants, on the ground that the fraud alleged was a mere expression of opinion as to value.

At Law.

Arthur L. Shipman and G. Edward Mills, for plaintiff.
Henry G. Newton and A. D. Penney, for defendants.

PLATT, District Judge. This is an action in tort, demanding damages resulting from a conspiracy on the part of the defendants to cheat and defraud the plaintiff by certain alleged false and fraudulent acts respecting certain real estate situated in New Haven. The alleged wrongdoing may be summarized as follows: Plaintiff is a New York corporation, dealing in bonds, stocks, securities, etc. Defendants are citizens and residents of New Haven, in the state of Connecticut. About January 1, 1902, said Donnelly owned certain real estate in New Haven. Crofutt, Church, and Calhoun were agents of the plaintiff. Scoville was a real estate agent, doing business as an appraiser. Phelps was a builder. Moorhead was a real estate agent. About January 6th they conspired and agreed together to cheat and defraud the plaintiff out of certain stocks in the manner hereinafter set forth. Crofutt, Church, and Calhoun, acting ostensibly for the plaintiff, but in fact for Moorhead and Donnelly, told the plaintiff that the real estate was worth \$48,800; that it ought to rent for \$4,000 per year, and that the reason why it was not so rented was that the former owner was an old lady, who objected to all tenants but those of a certain character; that the property was increasing in value, and had been doing so for some years, and would command a ready sale in the market. All this was false, and known to the five defendants mentioned last to be false, and was told to the plaintiff to obtain from it 3,000 shares of a certain stock in return for the property. The stock was worth \$5 per share, and more. To further the scheme, said five defendants procured Phelps and Scoville to appraise the property at \$48,800, and told the plaintiff that Phelps and Scoville were conservative appraisers in the city of New Haven, and in no way interested in the transaction, which the five knew to be false. On or about January 7, 1902, Scoville and Phelps signed an appraisal to the effect that the property was worth \$48,800, and said appraisal was delivered to the plaintiff by the five defendants. The appraisal was fraudulent and excessive, and put the value about three times too high, and was done by "defendants for the purpose of deceiving, cheating, and defrauding the plaintiff out of the ownership and possession of said shares of stock." To further carry out the scheme, Donnelly told the plaintiff that the property was easily worth the \$48,800, and that his reason for sacrificing it was that he was a contractor, and needed ready

money. Crofutt, Church, and Calhoun backed him up in his statements, all the time pretending to be acting for the plaintiff, thereby preventing the plaintiff, and intending to prevent the plaintiff, from making an intended investigation regarding the value. Plaintiff relied upon the false representations of the defendants, and turned over the stock for the property. The property was never worth \$48,800, and is now worthless. Moorhead got 600 shares of the stock "in consideration of his share of the profits, of and in pursuance of said conspiracy between the remaining defendants to defraud plaintiff." On discovering the fraud, the plaintiff, on April 14, 1902, demanded the stock, and tendered Donnelly a deed of the land, Donnelly and Moorhead refused to give back the stock, and Donnelly refused to accept the deed. Plaintiff claims \$17,000 damages.

Each defendant has demurred on the ground that the only act charged against him is that he expressed an opinion as to the value of the real estate which gave an excessive valuation. *Gustafson v. Rustemeyer*, 70 Conn. 132, 39 Atl. 104, 39 L. R. A. 644, 66 Am. St. Rep. 92, is cordially accepted as containing a very clear and comprehensive statement of the true rule, and exceptions thereto, as to the importance in evidence of estimated values of real estate. Even a casual reading of the complaint, however, settles the demurrer in the negative as to every defendant except Scoville and Phelps, and it is surely unnecessary to specify the reasons for reaching such a conclusion. Giving Scoville and Phelps the benefit of every doubt, it is clear that the plaintiff says that they, having been held out to the plaintiff as conservative real estate appraisers, signed a false and excessive appraisal, and that the appraisal was obtained by the other defendants for the purpose of carrying out their fraud, and was used for that purpose. If Scoville and Phelps signed a false and excessive appraisal, how can it benefit them to ask the court to imagine that they did not know what use was to be made of the evidence furnished by their deliberate action? Their profession, advantages, and capacity entitled their judgment to far greater weight than that of the ordinary citizen. They were peculiarly well fitted by training and experience to express opinions upon values of real estate. They were neither vendors nor vendees. Their signatures, appended to a document containing excessive valuations, which was put under the control of the other defendants, gave the others an added opportunity to work great harm. Such a document could be used effectively to deceive a distant plaintiff, who was led into a position of fancied, but false, security by the connivance of the others, several of whom were in a position which naturally evoked special trust and confidence.

It is alleged that the property was only worth one-third of the appraised value. It is hardly reasonable that experienced appraisers, acting with honest purpose, should fall so far short of the actual worth. When local controversies arise, and when any one of numberless motives impel, it is easy to find witnesses who will swear up values, and others equally worthy who will swear the same values down, and the greater the local agitation, and the more important the matter at stake, the greater the diversity; but looking at the allegations of the complaint in the case at bar, if there be eliminated from the face of the

papers a purpose to join in a conspiracy to overreach and injure the confiding absentee, no sound reason can be advanced to account for such a glaring discrepancy. It would seem that it is plainly the duty of Phelps and Scoville, as well as the other defendants, to make full and complete answer to the charges preferred against them: It is inconceivable that they can seriously expect to be released from all the consequences of their action before the disputed facts have been thoroughly presented and duly weighed in the balances.

Each demurrer is overruled, with costs.

THE JOSEPH M. CLARK.

(District Court, E. D. Virginia. November 26, 1902.)

1. COLLISION—STEAM VESSELS CROSSING—LEAVING WHARF WHEN ANOTHER VESSEL IS APPROACHING.

The steamer Belle Horton and the tug Joseph M. Clark were both making regular passenger trips, from a wharf, across Hampton Roads. In the evening, at a time when the Horton was due, and was in fact approaching the wharf, fully lighted up, and only 400 or 500 feet distant, the Clark cast off and started on the return trip, attempting to pass across the bows of the Horton, which, being to the starboard of the Clark, was the privileged vessel, under the navigation rules. A collision resulted, in which the Horton was damaged. *Held*, that the Clark was in fault, both for leaving the wharf at the time and under the circumstances, and for violation of the rules thereafter; the danger of collision being such as to impose upon her the duty of exercising the greatest care and skill from the time of leaving. Also *held*, under the evidence, that the Horton was not in fault.

In Admiralty. Suit for collision.

H. L. Lowenberg and H. H. Rumble, for libelant.
Hughes & Little, for respondent.

WADDILL, District Judge. The libel in this case is filed to recover damages sustained in a collision between the Belle Horton, a passenger steamer owned by the libelant, the Norfolk & Atlantic Terminal Company, and the Joseph M. Clark. The collision occurred about 9 o'clock on the night of the 12th of August, 1901, a short distance southwest of the pier owned by the Norfolk & Atlantic Terminal Company, at the terminus of its street car line, at Norfolk on the Roads, on the eastern side of Hampton Roads. At the time of the collision the steamer Belle Horton was owned and used by the Norfolk & Atlantic Terminal Company in the transportation of passengers between Norfolk and Newport News, from the terminus of its street car line, across Hampton Roads, to and from Newport News; and the Joseph M. Clark was temporarily chartered for the same service,—for the carrying of passengers between Norfolk on the Roads and Old Point Comfort, Va. The steamer and the tug thus engaged made hourly trips between the said places, connecting with the Norfolk & Atlantic Terminal Company's street car lines for Norfolk. On the night in question the Joseph M. Clark reached the pier in advance of the Belle Horton, and selected her berth upon

the western end of the pier; and the Belle Horton attempted to land upon the southwestern angle of said pier,—that being the proper berth, in the then condition of wind and tide. As the Belle Horton was making in to her berth, the Joseph M. Clark cast off and proceeded on the return trip to Old Point Comfort, and the two vessels came together; the starboard quarter of the steam tug raking the stem and bow of the Belle Horton, knocking off the stem and carrying away about four feet of the bow of the Belle Horton. The faults assigned against the Joseph M. Clark are: (1) Casting off in the existing conditions of wind and tide, when the Belle Horton was so near her pier; (2) not maintaining a proper lookout; (3) failing to keep out of the way of the Belle Horton; (4) attempting to cross her bow; (5) failing to stop and reverse its engines; and (6) increasing her speed. The faults charged against the Belle Horton are: (1) That she approached the pier at too high a rate of speed, at a time when it was known, or should have been known, that the tug was about to leave; (2) failing to have a proper lookout; (3) failing to keep out of the way the tug; (4) failing to obey the signal of two blasts from the tug, and the giving to the tug a cross-signal in reply thereto; (5) failing to slacken speed, stop, or reverse in time to prevent a collision; and (6) failing to starboard at the time of the collision.

The evidence was taken orally before the court, and a large number of witnesses examined, consisting, among others, of the officers and crews of the respective vessels; and, as to many of the material questions involved, the conflict is irreconcilable. It is not deemed necessary to enter into a lengthy discussion of the evidence, further than to say that it has been considered, and the conclusion reached is that the collision must be attributed to the fault of the steam tug Joseph M. Clark in negligently leaving her pier, without taking the precaution to observe the approaching steamer, and its negligent navigation after so leaving the pier. While the evidence of those navigating the two vessels is utterly irreconcilable as to just how the accident did happen, the account given by the libellant's witnesses is far more reasonable, in the essential particulars, than that of the respondent's; and, indeed, in the light of the undisputed evidence, and the indisputable physical facts surrounding the collision, it does not seem possible that it could have occurred as claimed by the respondent. It is quite apparent from the respondent's own evidence that no account was taken by those in charge of the Joseph M. Clark of the incoming steamer until after she had cast off and gotten under way, and not then until the lookout had taken time to coil the rope after casting off, that being also a part of his business. This of itself was gross negligence. It was known at the time, or should have been known, that the Belle Horton was then due at the pier, and that, under the then existing conditions of wind and tide, she would have to pass across the bow of the Joseph M. Clark in making her landing; and it is admitted that she was not more than four or five hundred feet from the pier at the time. The Joseph M. Clark's effort to leave the pier at all, under these circumstances, except by backing out, can only be attributed to the fact of its neg-

lect to observe the incoming steamer; and, for her failure in this respect, she, and not the incoming steamer, is responsible.

The faults assigned against the Joseph M. Clark in the matter of her navigation at the time of collision seem also to be established by the evidence. The two vessels were evidently approaching each other, from the moment the Joseph M. Clark cast off, in such manner as to involve risk of collision; and the Belle Horton was to the starboard side of the Joseph M. Clark, which imposed upon the Joseph M. Clark the duty of keeping out of the way of the Belle Horton, and required the latter vessel to keep her course and speed. Article 19, Act Cong. June 7, 1897 (30 Stat. 101 [U. S. Comp. St. 1901, p. 2883]). Under these circumstances, it was not only the duty of the Joseph M. Clark to keep out of the way of the Belle Horton, but, if the circumstances admitted, to avoid crossing ahead of her, and upon approaching the Belle Horton, if necessary, to slacken her speed, or stop or reverse. Articles 22, 23, Act supra. Notwithstanding these plain provisions of law, the Joseph M. Clark confessedly increased her speed, and attempted to cross ahead of the Belle Horton, and, as a consequence, the collision occurred. In the court's view, the danger of collision in the position in which the two vessels were after the Joseph M. Clark had cast off, and when those navigating her observed the Belle Horton, was imminent, and certainly such as to have called for the exercise of the greatest possible care and skill on the part of those navigating the Clark, and no further risk of collision should have been taken by the Joseph M. Clark. The presence of danger, or anticipated danger, was enough to admonish her of the necessity of complying with the rules of navigation. *The Carroll*, 8 Wall. 302, 19 L. Ed. 392; *The New York*, 175 U. S. 187, 270, 20 Sup. Ct. 67, 44 L. Ed. 126; *Steamship Co. v. Low*, 50 C. C. A. 473, 112 Fed. 161, 166, 172; *The Richmond* (D. C.) 114 Fed. 208.

The Belle Horton being the favored vessel on the occasion of the accident, should ordinarily have kept her course and speed; but if to do so would have involved absolute danger, or there was a failure on the part of her navigators to understand, from any cause, the course or intention of those navigating the Joseph M. Clark, it was her duty to immediately signify the same, by giving several short and rapid blasts, not less than four, and to have slowed down, as prescribed by rule 3 of article 18 of the inland rules, or article 28. This the Belle Horton did, and, indeed, she seems to have done everything in her power, under the circumstances in which she was placed, to avert the collision.

In what has been said, sight has not been lost of the fact that the collision in question occurred in the vicinity of a wharf where the steamers should have been managed with great caution, sounding their whistles as was necessary, to guard against collision or other accident. This, however, imposed an equal burden on each vessel; and, conceding that the Belle Horton should have given greater warning of her approach, still she had the right to suppose, on a dark night, with nothing to interrupt the view, and at a time when her arrival should have been anticipated, that those navigating the

Joseph M. Clark would have observed her approach, she being fully lighted up; and, besides, the Belle Horton had the right to assume that the Joseph M. Clark would not leave her pier and proceed across the bow of an incoming steamer.

The fault assigned against the Belle Horton, of coming in to the pier at too great a speed, is not established by the evidence; and certainly the speed at which she approached does not appear to have materially contributed to the accident, as the navigators of the Joseph M. Clark insist that there was ample room to have avoided the collision after the Belle Horton was observed by them and signaled to, had the navigators of the Belle Horton exercised proper care and caution on their part.

Under the view taken by the court, the collision was the result solely of the fault of the Joseph M. Clark, and a decree so finding may be entered.

THE JONAS H. FRENCH.

(District Court, D. Massachusetts. December 12, 1902.)

No. 1,376.

1. MARITIME LIENS—ENFORCEMENT—VESSEL IN CUSTODY OF ANOTHER COURT.

A vessel in the actual possession of receivers appointed by a circuit court is not subject to seizure on process from the district court for the same district in a suit in rem to enforce a demand which arose prior to the receivership, unless by permission of the circuit court.

In Admiralty. Libel for seamen's wages. On petition by receivers of the circuit court for discharge of vessel from custody.

Russell & Russell, for libellant.

Guy Cunningham and Loren E. Griswold, for receivers.

LOWELL, District Judge. This is a libel for seamen's wages, brought against the lighter Jonas H. French, a vessel which belonged to the Cape Ann Granite Company. Before the libel was filed, the circuit court for this district appointed receivers for that company. The receivers took possession of the Jonas H. French, which remained in their possession until seized by the marshal in this suit. They have petitioned this court to discharge the vessel from the custody of the marshal, and to restore it to them. The allegations of the petition were admitted to be true for the purposes of the hearing thereon.

In *Moran v. Sturges*, 154 U. S. 256, 274, 14 Sup. Ct. 1019, 38 L. Ed. 981, it was said:

"It is a rule of general application that, where property is in the actual possession of one court of competent jurisdiction, such possession cannot be disturbed by process out of another court."

The French was in the actual possession of receivers appointed by the circuit court. That this court should disturb that possession, the libellants must show either (1) that the possession of the receivers is not the possession of the court; or (2) that in this case the general rule stated in *Moran v. Sturges* does not apply.

1. In *Moran v. Sturges* the state court had appointed receivers for the owner of certain vessels. Thereafter those vessels were taken in custody by the marshal in a suit in admiralty to enforce a maritime lien. The supreme court held that the arrest was authorized, because:

"At the time these libels were filed, and the marshal seized the property, it had not been developed whether or when the receiver would or might give the security required and enter upon the discharge of his duties, and he had neither actual nor constructive possession." 154 U. S. 284, 14 Sup. Ct. 1019, 38 L. Ed. 981.

And the supreme court said:

"As between two courts of concurrent and co-ordinate jurisdiction, having like jurisdiction over the subject-matter in controversy, the court which first obtains jurisdiction is entitled to retain it without interference, and cannot be deprived of its right to do so because it may not have first obtained physical possession of the property in dispute. But where the jurisdiction is not concurrent, and the subject-matter in litigation in the one is not within the cognizance of the other, while actual or even constructive possession may, for the time being, and in order to avoid unseemly collision, prevent the one from disturbing such possession, yet, where there is neither actual nor constructive possession, there is no obstacle to proceeding, and action thus taken cannot be invalidated by relation." 154 U. S. 283, 284, 14 Sup. Ct. 1019, 38 L. Ed. 981.

The supreme court thus stated that a district court could not, under a libel in rem, arrest a vessel in the actual possession of the receivers of another court.

In *The Willamette Valley*, 66 Fed. 565, 13 C. C. A. 635, the circuit court of appeals for the Ninth circuit sustained a libel in rem for supplies furnished in San Francisco to a vessel then in the possession of a receiver appointed by a court of the state of Oregon. The court said:

"The powers of a receiver are bounded by the territorial limits of the court under whose authority he is appointed and acts. Within that territory the possession by the receiver of the property placed under his control will be respected by all other courts, and his possession may not be disturbed by process issued out of any court." 66 Fed. 566, 13 C. C. A. 637. "But the decisions establishing the immunity of the receiver's possession of the property brought by him into a foreign jurisdiction refer solely to the attempted enforcement of demands that existed before the property was taken under the control of the court." 66 Fed. 567, 13 C. C. A. 638. "When a receiver, under the order of his court, takes a vessel, the property of his trust, out of the jurisdiction of the court, and sends her into a foreign port under the charge of a master, he places her in the position of all other vessels engaged in like business. It is our judgment that in so doing he subjects her to the same conditions that other vessels are subject to." 66 Fed. 568, 13 C. C. A. 638.

In other words, the case was decided upon the ground that the district court did not improperly disturb a receiver's possession of a vessel by arresting it, outside the jurisdiction of the court appointing the receiver, for supplies furnished outside that jurisdiction, and after the receiver had taken possession. That the district court would not disturb the receiver's possession within the jurisdiction of the court appointing him, to enforce a maritime lien arising before his appointment, was clearly implied. There is nothing, therefore, in the cases just cited, to modify the general rule that the possession of the receiver is the possession of the court, and the French

must here be deemed to be in the custody of the circuit court for this district.

2. Is there anything in this case to modify the general rule stated in *Moran v. Sturges*, and to authorize the district court to disturb the possession thus taken by the circuit court? The libelants rely upon *Paxson v. Cunningham*, 63 Fed. 132, 11 C. C. A. 111. In that case a vessel in the possession of receivers appointed both by the circuit court for the Eastern district of Pennsylvania and by the circuit court for the district of Massachusetts was libeled for a collision in Boston harbor. The receiver filed a petition in the circuit court for the district of Massachusetts, asking an injunction to restrain the prosecution of the libel. *Cunningham* demurred, and the circuit court of appeals for this circuit sustained the demurrer. Mr. Justice Gray, in delivering the opinion, pointed out that St. 1888, c. 866, § 3 (25 Stat. 436 [U. S. Comp. St. 1901, p. 582]), expressly permitted a suit in personam against the receivers without leave of the circuit court previously obtained, and continued:

"The libel in rem against the steamboat for a wrong done by her while in the possession and employment of the receivers, if not within the terms of the statute, is within its reason and equity. Independently of the statute, there could be no objection to proceeding with that libel, so far as might be done without interfering with the possession of the receivers. *Heidritter v. Oilcloth Co.*, 112 U. S. 294, 304, 5 Sup. Ct. 135, 28 L. Ed. 729. And whether the libel in rem against the steamboat in the hands of the receivers is or is not considered as coming within the statute, it was clearly within the discretion of the circuit court to permit the libelants to establish and enforce their maritime lien in the district court in admiralty, as the appropriate tribunal to try and determine that matter."

See *The St. Nicholas* (D. C.) 49 Fed. 671.

That is to say, the court held that the receiver's petition must be dismissed because (1) the libel was expressly authorized by statute; or (2) might be allowed by the circuit court in its discretion. In the case at bar the libel is not authorized by statute, which allows suit only "in respect of any act or transaction of [the receiver's] in carrying on the business connected with the property." The undoubted right of the circuit court to permit the marshal to arrest the vessel under this libel does not help this court to make the arrest in the absence of permission. Had the circuit court, upon application made to it by the receivers, already refused to restrain proceedings on this libel, it may be that this court would treat the refusal to restrain as the equivalent of a permission to sue, but this has not happened here. It follows that *Paxson v. Cunningham* does not support the libelant's contention in this case. Other cases are clear to the point that a court of admiralty will not enforce a maritime lien by the seizure of a vessel in the custody of another court, though the other court is without authority to affect the lien by its judgments or decrees. *The Oliver Jordan*, Fed. Cas. No. 10,503, 2 Curt. 414; *Lewis v. Orpheus*, Fed. Cas. No. 8,330, 3 Ware, 143; *The Robert Fulton*, Fed. Cas. No. 11,890, 1 Paine, 630; *The E. L. Cain* (D. C.) 45 Fed. 370; *The J. G. Chapman* (D. C.) 62 Fed. 939. See *The Resolute*, 168 U. S. 437, 18 Sup. Ct. 112, 42 L. Ed. 533, and *Taylor v. Carryl*, 20 How. 583, 15 L. Ed. 1028. The dis-

senting opinion of the chief justice in the last-mentioned case shows that he agreed with the counsel for the libelants in the case at bar, and understood that the majority of the court decided otherwise.

Of the unreported case of *The Williamsport*,—the admiralty suit under consideration in *Paxson v. Cunningham*,—it is sufficient to say that Judge Nelson refused to restore the vessel to the receivers without giving any reason for his refusal; and this may have been rested either upon the statute, or upon the fact that the lien there in question had arisen since the receiver's possession.

The receivers' petition is granted as to the release of the vessel, but the order of restoration will not issue for three days, in order that the libelants may apply to the circuit court for leave to proceed with their libel.

In re HOWELL.

(District Court, M. D. Pennsylvania. December 8, 1902.)

1. ELECTIONS—CONTESTED ELECTION OF CONGRESSMAN—PRESERVATION OF EVIDENCE.

Under Rev. St. §§ 109, 123 [U. S. Comp. St. 1901, pp. 60, 63], which authorize a district judge of the United States to issue subpoenas and orders for the purpose of obtaining testimony and papers to be used as evidence in case an election of congressman is contested, such judge has power and it is his duty, on proper application, to require the ballots cast at the election to be taken from the boxes and preserved, where it is shown that they are desired as evidence by one of the parties to the contest, and that under the state law they would be destroyed before they could be used; and it is immaterial whether or not the issues to the contest have been made up so as to authorize the taking of testimony when such application is made.

At Law. Application for order for the production of papers, under sections 109 and 123 of the Revised Statutes [U. S. Comp. St. 1901, pp. 60, 63], in the contested election of congressmen.

At the general election, November 4, 1902, in the Tenth congressional district of Pennsylvania, George Howell, the Democratic candidate, received a majority of 461 votes, and thereupon his opponent, William Connell, gave notice of contest. Under the law of Pennsylvania, the ballots cast at the general election in November are kept in the ballot boxes until the municipal elections held in February, and are then taken from the boxes and destroyed to make way for that election. For the purpose of obtaining and preserving the ballots cast at the election in contest, a petition was presented by the contestant to Archbald, District Judge, setting forth: "First. That on the 4th day of November, 1902, there was held in the county of Lackawanna, state of Pennsylvania, which comprises the Tenth congressional district of Pennsylvania, an election for the purpose of electing a member to the house of representatives of the 58th congress of the United States. Second. That at the said election there were returned and counted for your orator 13,139 votes, and for the defendant 13,600 votes. Third. That in the several election districts in the said congressional district at the said election there were cast, returned, and canvassed for George Howell, for member of the house of representatives, of the said 58th congress, illegal, false, and fraudulent ballots, the said fraud, falseness, and illegality being committed, as your orator by his attorneys is informed and believes, in the following ways: (a) There were cast and counted at said election numerous votes by persons who were not registered, and who did not make legal proof of their right to vote at said election. (b) There were cast and counted at said election

numerous votes by persons who were not of the age of 21 years. (c) There were cast, counted, and returned at said election numerous votes by persons who were not born in the United States, and had never been naturalized in conformity with the law, at the time they and each of them cast said ballots at said election. (d) There were cast and counted at said election, in the several election districts, numerous votes by persons who had failed to pay taxes in conformity with law. (e) There were cast and counted at said election, in the several election districts, numerous votes by persons who were not entitled to vote according to law on account of lack of residence, as required by law, in said election districts. (f) That at said election in several districts of said congressional district the election officers were not sworn in conformity with law, and were not qualified to hold an election or make return or count of the votes cast therein. (g) That in the several election districts the count by the election officers was illegal, false, and fraudulent, and in violation of the election laws. (h) That in the several election districts original ballots were secured by agents of the defendant and cast by people secured by them. (i) That election officers fraudulently counted ballots marked X in the circle at the top of the Democratic column for the defendant, George Howell, notwithstanding the fact that the said defendant was debarred from being a candidate on the Democratic ticket for membership in the house of representatives in the 58th congress of the United States by a decision of a court law of the commonwealth of Pennsylvania. Fourth. That not only were many of said ballots fraudulently counted and returned, but many were also irregularly marked. Fifth. That, upon a fair and lawful count of the duly authorized ballots, your orator would be decided to be elected by a large majority. Sixth. That proceedings have been instituted and are now pending and suit has been begun to the extent of serving notice upon the defendant by your orator of a contest to determine the right of the defendant to a seat as member of the house of representatives of the 58th congress of the United States. Seventh. That your orator, by his attorneys, is informed and believes that there is a plan to fraudulently tamper with the ballot boxes, and to change the ballots as they now exist. Eighth. That, according to the statutes, the present ballots must be destroyed before the election to be held in February, 1903, in order that the boxes may be used in the said February election. Ninth. That the said ballots will be needed as evidence in the trial of the above-mentioned suit to determine the right of the defendant as a member of the house of representatives in the 58th congress of the United States, notice of which has been served upon the defendant by your orator, to prove fraud, fraudulent counting, and the other allegations hereinbefore made. Tenth. That the said ballots will not be needed as evidence to prove fraud, illegality, and fraudulent counting, before they would necessarily be destroyed in conformity with the statute law of Pennsylvania. Eleventh. That said ballots should be preserved to defeat fraud, and to perpetuate the evidence in the suit now begun to determine the right of your orator to be seated as a member of the house of representatives in the 58th congress of the United States from the Tenth congressional district of Pennsylvania. Twelfth. That if said ballots are tampered with through fraud or dishonesty, or stolen, or destroyed in conformity with the statute, the evidence which will be needed in the above-stated contest case, in which your orator is plaintiff, will be impaired or destroyed, and your orator will be irreparably injured thereby. Thirteenth. That there is no remedy at law to preserve the ballots until such times as they may be needed as evidence in the case stated brought by your orator against the defendant, other than as provided by sections 109 and 123 of the Revised Statutes. Fourteenth. Your orator prays that a subpoena or subpoenas may issue from your honor directed to the custodians of the ballot boxes of each and every election district of the said congressional district, directing that said custodians be and appear before your honor, as judge of the district court of the United States for the Middle district of Pennsylvania, in the court room in the federal building at Scranton, upon a day or days to be designated by your honor, and to bring with them the ballot boxes of each and every election district in the said congressional district, containing the ballots and all other official papers which be therein, to be deposited with your honor for safe-keeping until such time

as the said boxes may, after a hearing by a decree or order issuing from your honor, be emptied of the ballots and other official papers, and said ballots and other official papers be sealed up and preserved until such time as they may be needed as evidence in the case brought by your orator against the defendant, in which case proceedings have been instituted and are now pending."

In pursuance of the petition the following notice was served:

"Hon. George Howell—Sir: You are hereby notified that application will be made to Hon. R. W. Archbald, judge of the U. S. district court, at his chambers in the United States building, in Scranton, at three o'clock in the afternoon of the 8th day of December, 1902, for an order directing that the ballots and contents of the several ballot boxes in the several election districts in the county of Lackawanna be forthwith collected, sealed, and deposited in a place of safety, pending the disposition of and final judgment in above-stated case.

"R. H. Holgate, of Counsel for Contestant."

R. H. Holgate, for petitioner.

C. Ballentine, for respondent.

ARCHBALD, District Judge (orally). The authority given by the section of the Revised Statutes referred to cannot be questioned, and I cannot refuse an application which is brought within its terms. It is immaterial whether an issue has yet been made up or not, because if testimony were being taken I would have no right to pass upon its relevancy or irrelevancy. I am also of the opinion that it is within the authority given by the statutes to require the production of these ballots. They are important evidence, if desired, and before they can be used they will be destroyed under the state law to make way for the coming municipal elections. The only question is how best to get at it. I could require the parties in whose custody the boxes now are to produce them before me and have the boxes opened in my presence and the contents of each taken out and sealed up in separate and convenient packages. But why cannot this be done just as well through the medium of commissioners appointed by the court and acting for it? This is the course pursued in contested elections in the state courts, and, while the analogy is not complete, yet the practice is at least suggestive. I am inclined to pursue it, and, if counsel for the respective parties to this proceeding will each nominate some one in whom I have confidence, I will appoint them to act.

The following order was subsequently made:

In re Contested Election of George Howell, Congressman-Elect for the Tenth Congressional District of Pennsylvania.

On due application made by William Connell, contestant, it is hereby ordered that the ballot boxes, with the ballots and contents of the same, which were used in the general election held November 4, 1902, in the Tenth congressional district of Pennsylvania, composed of the county of Lackawanna, be forthwith produced, by the several parties in whose possession or custody they may be, before the undersigned, United States district judge of the Middle district of Pennsylvania, wherein the said congressional district is situated, at his chambers in the federal building at Scranton; and P. W. Stokes and John J. Toohey are hereby appointed commissioners to receive in that behalf the said ballot boxes, and the contents of the same, so ordered to be

produced, with authority to open the said ballot boxes at the several places where they may be found, and to take therefrom all ballots, papers, or other contents, and the same to severally inclose and seal up in convenient packages, keeping separate the ballots, papers, and contents of each box, noting at the time the condition in which each of the said ballot boxes is found, and where and in whose custody found; and, having identified the said packages with their signatures and seals, they shall deliver and deposit the same with the clerk of the said district court at his office in the said federal building.

Witness my hand this 8th day of December, A. D. 1902.

R. W. ARCHBALD, District Judge.

THE O. L. HALLENBECK.

OLSEN v. CAHILL.

(District Court, E. D. New York. November 26, 1902.)

1. TOWAGE—NEGLIGENCE OF TUG—LIABILITY FOR LOSS OF TOW.

While a tug was engaged in towing two scows from New York to the dumping grounds and return in the evening, one of the scows went adrift, and was lost with the man in charge. The tug did not discover the loss until four hours afterward, on the return trip. The sea was rough, requiring vigilance, and the night was clear. Also, after the scow went adrift, two other vessels in the vicinity blew alarm signals to call the tug's attention to her, and the master noted that two lights were absent from the tow, but no further investigation was made. *Held*, that the tug was chargeable with gross negligence and inattention to her tow, which rendered her liable for the loss.

2. ADMIRALTY—TORTS CAUSING DEATH—RECOVERY OF DAMAGES.

The next of kin of a scowman, lost through the negligence of a tug, were two sisters who supported themselves, but it was shown that the deceased had promised to take them back to Norway to live and to supply the money required. *Held*, that such evidence was sufficient to warrant the court in awarding damages for the death against the owner of the tug in the sum of \$500.

In Admiralty. Suit against a tug for the loss of a scow, and action against the owner to recover for the death of the scowman.

Albert A. Wray, for Morris & Cumings Dredging Co.

Fredk. W. Rowe, for Olsen and Albert A. Wray, advocate.

James J. Macklin, proctor for claimant and respondent.

THOMAS, District Judge. In February, 1901, the tug Hallenbeck undertook to tow two scows to and from the mud buoy off Sandy Hook Lightship, and on the way No. 38, the after scow, went adrift, at about 8 o'clock in the evening, and was lost with her scowman. None of the 10 men on the tug discovered the loss until, after rounding the dumping buoy, the tug reached Craven Shoals, at about 12 o'clock midnight, on her return trip. Thus for four hours the Hallenbeck went on her way, at least one hour of the time outward bound, and for three hours inward bound, and did not know that half of the burden of her tow had been released. Such failure to know the condition of her tow seems impossible in the employment

of ordinary care. Why should she have known it? The observance of requisite oversight of her tow should have revealed it. The wind was blowing a gale, and this, with the tide, made rough water. This condition demanded vigilance. The night was clear. This promoted discovery. Moreover, two tugs in the neighborhood of the tow blew alarm signals to call attention to the scow adrift; those on the tug heard, and the captain and others on the tug claim to have looked back. A lantern was waved by some one on the tow; the mate in actual charge of the tug at the time saw it; he called the master, who looked with glasses, and discovered that two lights were absent on the tow, but he did nothing by way of investigation. The master and the mate heard the alarm whistles, the mate saw the waving light, the master saw that two lights were missing. Why was nothing done? The excuse of the captain is, variously, that he thought his tow was crowding the other tows; that the scows were asking for an opportunity to extend their sea line; but the variety of his explanations impairs the validity of his excuse.

It may be that the contentions of the claimant and respondent respecting other accusations of negligence are correct; that is not determined. The startling fact is that such was the gross inattention of those navigating the tug that one of the vessels in tow went adrift and was lost, with the man on board, and the discovery was made only after four hours. Whatever the tug had done or had not done, either by way of vigilance or omission in other respects, this failure to keep track of her tow, and render assistance to a part that had gone adrift, seems such inexcusable negligence that there is no hesitation in awarding a decree for the loss of the scow. The fact that the mate, unlicensed for such service, was in charge of the tug, and that there were two women aboard of the tug, in violation of law and good morals, may account for the preoccupation of the captain and mate.

The next of kin were sisters of the deceased scowman. They were supporting themselves. There had been conversation between them and the deceased that at some time they would go back to Norway and live upon a farm owned by the decedent. There is evidence that he had promised to supply the money for the return of the sisters to Norway. This evidence does not furnish a very substantial basis for pecuniary damages, but, employing the latitude that is permitted, it is considered that there was some financial loss, and that the damages on account of the death amounted to the sum of \$500, for which sum the administratrix will have a decree.

FRANCKLYN et al. v. UNITED STATES.

(Circuit Court, S. D. New York. November 12, 1902.)

No. 3,202.

1. CUSTOMS DUTIES—CRUDE HEMATITE ORE.

Crude hematite ore, which in its present state cannot be used as a pigment or color, is assessable at 40 cents per ton as "iron ore," within paragraph 121, Tariff Act July 24, 1897 [U. S. Comp. St. 1901, p. 1636], and not at 30 per cent. ad valorem, as "color," under paragraph 58.

Appeal by the Importers from a Decision of the Board of General Appraisers Which Affirmed the Classification by the Collector of the Importation in Question.

Howard T. Walden, for importers.

Henry C. Platt, Asst. U. S. Atty.

TOWNSEND, Circuit Judge. The merchandise in question is a crude mineral product, which was assessed for duty at 30 per cent. ad valorem, under the provisions of paragraph 58, Tariff Act July 24, 1897 [U. S. Comp. St. 1901, p. 1630], as a "color," and was claimed to be dutiable at 40 cents per ton, as "iron ore," under paragraph 121 of said act [U. S. Comp. St. 1901, p. 1636]. The paragraphs bearing on this question are the following:

"Par. 58 [U. S. Comp. St. 1901, p. 1630]. All paints, colors, pigments, lakes, crayons, smalts and frostings, whether crude or dry or mixed, or ground with water or oil or with solutions other than oil, not otherwise specially provided for in this act, thirty per centum ad valorem; all paints, colors and pigments, commonly known as artists' paints or colors, whether in tubes, pans, cakes or other forms, thirty per centum ad valorem."

"Par. 121 [U. S. Comp. St. 1901, p. 1636]. Iron ore, including manganiferous iron ore, and the dross or residuum from burnt pyrites, forty cents per ton: provided, that in levying and collecting the duty on iron ore no deduction shall be made from the weight of the ore on account of moisture which may be chemically or physically combined therewith; basic slag, ground or unground, one dollar per ton."

The merchandise is in fact crude hematite ore, or iron ore. In its present state it cannot be used as a pigment or color, and, even if it be assumed that it is in fact a color or pigment, then it is a color specially provided for as iron ore in paragraph 121. Congress having seen fit to levy a duty of 40 cents per ton on iron ore without qualification as to its use, and without the limitation "not specially provided for," such designation must stand. In the Vandegrift Case (C. C.) 107 Fed. 265, where a similar article was considered, the issue was not the same as that raised by this protest. Upon an issue practically identical with that raised herein, the board, in G. A. 1,312, held, in construing a similar provision of the act of 1890, that a like article was an iron ore, and not a color.

The decision of the board of general appraisers is reversed.

RICHTER v. HANNEMAN.

(Circuit Court, S. D. New York. November 11, 1902.)

1. SET-OFF—CLAIM IN DIFFERENT RIGHTS—PERSONAL AND REPRESENTATIVE CAPACITY.

Since a husband cannot recover choses in action of which his wife died seised, and to which he is entitled as a distributee, except through administration, such claims are not due to him personally, and cannot, therefore, be set off against a personal debt due by him to the plaintiff.

Wm. R. Baird, for demurrer.
Henry Parsons, opposed.

WALLACE, Circuit Judge. The plaintiff has demurred to the defendant's answer setting up a counterclaim. The action is brought by the executrix of Ludemann to recover the amount of a loan made by Ludemann to the defendant. The answer sets up as a counterclaim a debt owing by Ludemann at the time of his death to Amanda Hanneman, and alleges that before the commencement of the action she died leaving the defendant, who was her husband, and one daughter surviving, and that letters of administration upon the estate of the deceased wife were duly granted to the defendant by the surrogate having jurisdiction.

In support of the demurrer the plaintiff relies upon the well-settled rule that the defendant sued for a debt due by him personally cannot set off a demand due to him in a representative capacity. In support of the answer the defendant, while conceding this rule, claims that it is inapplicable upon the facts alleged, because, as husband, he became the owner of all the choses in action of his deceased wife, and his title was neither fortified nor impaired by his subsequent appointment as administrator.

It is the law of this state that the husband upon the death of his wife becomes entitled to the choses in action which belonged to her, and of which she had not made any disposition, testamentary or otherwise, and which he has reduced to his possession. He may release them, or take payment of them without administration, if he can get payment. There has been some difference of opinion in the courts of this state as to whether his title accrues by virtue of his right to administer, or independently, but the weight of authority is to the effect that where the wife leaves no descendant the husband's title is not affected by the granting of administration. *Robins v. McClure*, 100 N. Y. 328, 3 N. E. 663, 53 Am. Rep. 184, disapproves *Barnes v. Underwood*, 47 N. Y. 351, upon this point, and follows *Ransom v. Nichols*, 22 N. Y. 110, *Ryder v. Hulse*, 24 N. Y. 372, and *Olmsted v. Keyes*, 85 N. Y. 602. The statute provides that where the wife leaves a descendant the husband shall be entitled to the same distributive share of her personal estate as a widow would have in the estate of her deceased husband. The courts of New York have not decided that in such a case the husband takes title otherwise than by administration, and as the statute secures him merely a distributive share of the effects it would seem that he could not. And they have never decided that where a chose in action is in the

possession of another the husband can recover it without assuming administration. If administration is needed to reduce the choses in action to possession the husband is entitled to letters, but until he has obtained possession he cannot maintain an action, but to do so he must assume administration and recover then in his capacity as administrator; and this is the rule which all the adjudications assume to exist. *Whitaker v. Whitaker*, 6 Johns. 112; *Hunter v. Hallett*, 1 Edw. Ch. 388; *Latting v. Latting*, 4 Sandf. Ch. 31; *Jenkins v. Frever*, 4 Paige, 51; *Woodin v. Bagley*, 13 Wend. 453; *Westervelt v. Gregg*, 12 N. Y. 202-206, 62 Am. Dec. 160; *Grosvenor v. Lane*, 2 Atk. 180; *Bourne v. Crofton*, 2 Moll. 318.

As the defendant could not maintain an action upon the demand set up in his answer, it is not good as a counterclaim, and the demurrer should be sustained; and it is so ordered.

SCHERING et al. v. UNITED STATES.

(Circuit Court, S. D. New York. January 25, 1900.)

No. 2,137.

1. CUSTOMS DUTIES—DRUGS—HYOSCIN HYDROBROMATE.

Hyoscin hydrobromate, shown to be a chemical salt of solely medicinal use, in the preparation of which alcohol is necessarily used, is dutiable under Tariff Act 1890, par. 74, as a medicinal preparation in the preparation of which alcohol is used, and not under paragraph 76, as a chemical compound or salt.

2. SAME—SALOL.

Salol, being a medicinal preparation, in the preparation of which alcohol may or may not be used, is dutiable under Tariff Act 1890, par. 76, as a chemical compound or salt, and not under paragraph 74, covering medicinal preparations in the making of which alcohol is used.

Appeal by the importers from a decision of the board of United States general appraisers which affirmed a decision by the collector of customs at the port of New York.

Albert Comstock, for appellants.

Charles D. Baker, Asst. U. S. Atty.

TOWNSEND, District Judge (orally). The merchandise in question consists of hyoscin hydrobromate and salol, assessed for duty, under the provisions of paragraph 76 of the tariff act of 1890, at the rate of 25 per cent. ad valorem, as "chemical compounds or salts," and claimed by the importers to be dutiable at the rate of 50 cents per pound, under the provisions of paragraph 74, as "medicinal preparations * * * in the preparation of which alcohol is used."

As to the hyoscin hydrobromate, the testimony of the chemist for the importers, concurred in by that of the chemist for the United States, is to the effect that it is a chemical salt whose use is solely medicinal, and that in its preparation alcohol is necessarily used. This brings the case within the rule laid down in *Fink v. U. S.*, 170 U. S. 584, 18 Sup. Ct. 770, 42 L. Ed. 1153.

Salol is a medicinal preparation in the preparation of which alcohol may or may not be used. It is admitted that alcohol was used in the preparation of this particular salol. In these circumstances, I am constrained to follow that portion of the opinion in *U. S. v. Battle & Co.*, 54 Fed. 141, 4 C. C. A. 249, in which the court says, "The result of holding the present importation dutiable under that clause [paragraph 74] would be to impose a different rate of duty on the same drug, depending upon the process of manufacture."

The decision of the board of general appraisers is reversed as to hyoscin hydrobromate, and affirmed as to salol.

UNITED STATES v. SCHERING et al.

(Circuit Court, S. D. New York. November 11, 1902.)

No. 3,141.

1. CUSTOMS DUTIES—DRUGS—CHLORAL HYDRATE.

Chloral hydrate is dutiable under Tariff Act 1897, par. 67 [U. S. Comp. St. 1901, p. 1631], as an alcoholic medicinal preparation, and not under paragraph 66 [U. S. Comp. St. 1901, p. 1630], as a medicinal preparation not containing alcohol, or in the preparation of which alcohol is not used.

Appeal by the United States from a decision of the board of United States general appraisers.

Charles D. Baker, Asst. U. S. Atty.
Albert Comstock, for importers.

TOWNSEND, Circuit Judge. This case involves an importation of chloral hydrate, under the tariff act of 1897 [U. S. Comp. St. 1901, p. 1626]. Duty was assessed on it at 55 cents per pound, as a medicinal preparation, alcoholic, under paragraph 67 of said act [U. S. Comp. St. 1901, p. 1631]. The importers claim that they should pay but 25 per cent. ad valorem, under paragraph 66 [U. S. Comp. St. 1901, p. 1630] of said act, as a medicinal preparation not containing alcohol, or in the preparation of which alcohol is not used. Protestants make other claims, which it is unnecessary to consider.

Counsel for the United States rests his contention upon a recent decision of the circuit court (*Battle & Co. Chemists' Corp. v. U. S.*, 108 Fed. 216), in which Judge Adams reached a conclusion contrary to that reached in this circuit by the writer in the case of *Schering v. U. S.* (suit No. 2,137, decided January 25, 1900) 119 Fed. 472. The decision in *Battle & Co. Chemists' Corp. v. U. S.* also appears to be in conflict with the decision of the circuit court of appeals in this circuit in the case of *Koechl v. U. S.*, 33 C. C. A. 363, 91 Fed. 110. In these circumstances, I feel constrained to follow the decisions in this circuit.

The decision of the board of appraisers is affirmed.

GRAY v. SCHNEIDER.

(Circuit Court, S. D. New York. November 8, 1902.)

1. INSPECTION OF DOCUMENTS BEFORE TRIAL—RIGHT TO RELIEF.

Rev. St. U. S. § 724 [U. S. Comp. St. 1901, p. 583], provides that in the trial of actions at law the federal courts may, on motion and notice, require the parties to produce books or writings in their possession or power, containing evidence pertinent to the issue, in cases and under circumstances where they might be compelled to produce the same by the ordinary rules of chancery. *Held*, that a party litigant had the right to compel production and inspection of books before trial at law, especially where a bill of discovery had shown that books existed which contained the entries sought to be proved.

2. SAME—NATURE OF ORDER.

An order for the inspection by a party litigant, before trial at law, of books which contain entries with which he has no concern, and which he ought not to see, will be conditioned to require the deposit of the books in the clerk's office, and to provide for the attendance of a representative of the opposite party, the relevancy of contested entries to be determined in the first instance by the clerk, with summary application for review thereof to the judge at chambers.

Motion to Compel Production and Allow Inspection of Books before Trial at Law. Rev. St. U. S. § 724 [U. S. Comp. St. 1901, p. 583].

Carlisle Norwood, for the motion.

Fraye, Smith, White & Seaman, opposed.

LACOMBE, Circuit Judge. The practice in the past has been somewhat unsettled, but the exhaustive opinion in *Victor G. Bloede Co. v. Joseph Bancroft & Sons Co.* (C. C.) 98 Fed. 175, shows that the weight of authority is in favor of the relief prayed for, especially where a bill of discovery has elicited the information that books exist which contain the entries defendant seeks to prove. Indeed, since the act of 1892 the Code practice is also available. The books may contain other entries with which he has no concern, and which he ought not to see. The order, therefore, while requiring their deposit in the clerk's office, will provide for the attendance of some representative of the plaintiff while defendant is conducting his examination. As to entries which plaintiff may contend are not relevant, and should not be disclosed, the same shall be inspected in the first instance by the clerk; and, if the parties or either of them are not satisfied with his decision thereon, application to review it may be made summarily to any judge of this court in chambers.

KENNY v. KNIGHT et al.

(Circuit Court, D. Massachusetts. December 9, 1902.)

No. 1,269.

1. CONTRACTS—ACTION FOR BREACH—DEMURRER TO COMPLAINT.

A demurrer to the complaint in an action on a contract, on the ground that the contract is vague, indefinite, incapable of enforcement, and void for uncertainty, goes to the right of the plaintiff to maintain the action, and the question whether the damages specifically claimed are such as are recoverable for breach of the contract declared on cannot be considered.

2. SAME—POWER TO TERMINATE—EFFECT.

Though a contract shows on its face that it is terminable at the will of either party on reasonable notice, it does not follow that it is not obligatory upon the parties so long as they continue to act under it, before revoking or terminating it.

3. SAME—CONSTRUCTION.

A contract recited that defendants were sole owners of a fire extinguisher, together with the patents under which it was made and sold. It was provided that plaintiff should have charge of the introduction of the extinguisher in a certain state, and that defendant might annul the contract by notice in writing. *Held*, that the contract did not show that the term contemplated by the parties was the term of the patent.

On Demurrer to Declaration.

Elder & Whitman, for plaintiff.

Charles A. Castle, for defendants.

BROWN, District Judge. The cause of demurrer is stated, as follows:

"The contract declared on herein by plaintiff, a copy of which is annexed to the declaration, which said contract is the basis of plaintiff's action, is vague, indefinite, incapable of enforcement, and void for uncertainty."

Under this general demurrer, the question whether the damages specifically claimed are such as are recoverable for breach of the contract declared on cannot be considered. The demurrer goes to the right of the plaintiff to maintain an action upon the contract, and not to the measure of damages for a breach of such contract.

The sole ground presented upon argument to support the contention that the plaintiff has not stated such a cause of action as entitles him to relief in law is that the written contract contains no express limit as to time, and is therefore terminable by either party. Even were we of the opinion that the written contract showed upon its face that it was terminable at the will of either party, or upon reasonable notice, it would not follow that the agreements therein contained would not be obligatory upon the parties so long as they continued to act under such contract, before revoking or terminating it. It cannot be inferred from the declaration that there has been any revocation or termination of the contract.

Nor is it at all clear that the defendants are right in their contention that the contract itself contains no provision as to its continuance. The written memorandum of agreement, which is made part of the declaration, recites that the defendants are sole owners of a fire ex-

tinguisher known as the "Underwriters' Fire Extinguisher, No. 6," together with the letters patent of the United States thereon, and under which said extinguisher is manufactured and sold; that the defendants are desirous of availing themselves of the experience and services of the plaintiff in the introduction and sale of said extinguisher in the states of North and South Carolina. It is agreed that the defendants shall sell and deliver to the plaintiff as many fire extinguishers as the plaintiff shall order. The price, and the circumstances under which the price can be varied, are clearly determined by the contract. By the ninth clause the plaintiff agrees, "after the first ninety (90) days, to take forty (40) or more extinguishers per month, and, failing to do so for any three consecutive months thereafter, that the parties of the first part [the defendants] shall have the right of annulling this contract by giving notice in writing to the last known address of the party of the second part [the plaintiff] thirty (30) days in advance." The plaintiff contends that upon an interpretation of the whole contract, which relates to a patented article, it appears that the parties contemplated the term of the patent as the term of their agreement. This contention is, in my opinion, erroneous. The mere recital of the fact that letters patent of the United States cover the manufacture and sale of the articles is of no significance; and there is nothing in the agreement from which an intention to assign or to license, or to continue the agreement for the term of the patent, can be inferred.

It is unnecessary, upon this demurrer, to determine whether the defendants are bound, under the first and ninth clauses of the written contract, to furnish the extinguishers so long as the plaintiff orders 40 or more per month. It is sufficient to say that the declaration sets out an agreement by the defendants to sell the plaintiff, at a fixed price, as many fire extinguishers as he should order, and alleges that the plaintiff has ordered 527, which the defendants refused to sell and deliver. The declaration alleges also, in substance, that the agreement in writing was in force at the time of this refusal to sell and deliver, and also alleges breaches of other provisions of the contract. Upon an examination of the declaration and of Exhibit A, it cannot be said, as a matter of law, that the breaches of contract declared upon are legal impossibilities.

Demurrer overruled.

LORSCH et al. v. UNITED STATES.

(Circuit Court, S. D. New York. November 10, 1902.)

No. 2,783.

1. CUSTOMS DUTIES—IMITATION PEARLS—COMPETENCY OF EXPERTS.

Dealers in precious stones only are not competent to testify as to the commercial uses of ornaments claimed to be imitations of precious stones.

2. SAME—CLASSIFICATION.

Imitations of pearls, made of paste or glass, and mounted on wires, used for jewelry or ornamental purposes, are dutiable at 10 per cent. ad valorem, under paragraph 454 of the tariff act of 1890 and paragraph 338 of the tariff act of 1894, as "imitations of precious stones not set,"

and not under paragraph 108 of the act of 1890 as "manufactures of glass, not specially provided for," or under paragraph 351 of the act of 1894 as "manufactures of paste not specially provided for."

Appeal by the Importers from a Decision of the Board of General Appraisers Which Affirmed the Classification by the Collector of the Importation in Question.

Albert Comstock, for importers.

Charles D. Baker, Asst. U. S. Atty.

TOWNSEND, Circuit Judge. The merchandise in question comprises various cheap representations of valuable stones and pearls used for jewelry and other ornamental purposes. A portion of it was assessed for duty as "manufactures of glass, not specially provided for," at 60 per cent. ad valorem, under the provisions of paragraph 108 of the act of October 1, 1890, and another portion under the provisions of paragraph 351 of the act of August 27, 1894, as "manufactures of paste, not specially provided for," at 25 per cent. ad valorem. It was claimed to be dutiable at 10 per cent. ad valorem, as "imitations of precious stones, * * * not set," under paragraphs 454 of the act of 1890 and 338 of the act of 1894. Some of the ornaments are set on posts. There is no contention on the part of the importers that they are not dutiable. That the ornaments are made of paste or glass is not disputed. That they are not set, except such as are on posts, is proved. They are not imitations of what are technically known as precious stones, which, according to the testimony, comprise only diamonds, rubies, emeralds, and sapphires, and perhaps cats' eyes and alexandrites. The great preponderance of testimony—in fact, almost the unanimous testimony—of dealers in such articles is that they are universally known in trade and commerce as imitations of precious stones. The chief question at issue is whether there is sufficient evidence under the rule to support the finding of the board of appraisers that they are not thus commercially known. It is admitted that the trade designation must control. The witnesses produced by the government who deal in real precious stones only, limited to the four or six varieties already stated, are not dealers in any imitations of precious stones, either in the technical or commercial sense. They are not, therefore, competent to testify as to the commercial uses of these ornaments. Furthermore, it appears from their testimony that the reason why they state that these articles are not imitations of precious stones is because they are not imitations of the diamond, ruby, emerald, sapphire, etc. It appears, however, from the decisions of the courts that various other stones, such as those simulated by these exhibits, have been held to be precious stones commercially in this country. In these circumstances it must be found that the definition of the experts called by the government is too limited, and that the evidence as to trade designation does not sufficiently support the finding of the board. The question as to whether imitations of pearls are imitations of precious stones has been especially pressed upon the court in the argument. Without reference to whether pearls are precious stones or not, it must be found on the evidence in this case that the imitations of pearls mounted on wires and shown in the

suit in question are known in trade and commerce as imitations of precious stones.

The decision of the board of appraisers is reversed.

UNITED STATES v. NORDLINGER.

SAME v. McELROY.

(Circuit Court, S. D. New York. November 10, 1902.)

Nos. 2,875, 2,926.

1. CUSTOMS DUTIES—CANARY SEED.

Canary seed is not free from duty, under paragraph 656 of the tariff act of 1897 [U. S. Comp. St. 1901, p. 1687], as "grass seeds," not specially provided for, but is dutiable at 30 per cent. ad valorem, under paragraph 254 [U. S. Comp. St. 1901, p. 1650], as "seeds, not specially provided for."

Appeals by the United States from a Decision of the Board of United States General Appraisers.

Henry C. Platt, Asst. U. S. Atty.

A. E. Nordlinger, for importers.

TOWNSEND, Circuit Judge. The merchandise in question is canary seed, returned by the collector for assessment of duty at 30 per cent. ad valorem, as "seeds, not specially provided for," under paragraph 254 of the act of 1897 [U. S. Comp. St. 1901, p. 1650]. The importers protested, and the board of general appraisers sustained the protest, and held that canary seed was a grass seed, and free of duty, under the provisions of paragraph 656 of said act [U. S. Comp. St. 1901, p. 1687], for "grass seeds," not specially provided for. No testimony was introduced before the board of appraisers, but considerable has been taken in this court by both parties. Canary seed has always been admitted free of duty. In the prior acts of 1890 (paragraph 699) and 1894 (paragraph 611) it was specifically exempted from duty. Paragraph 656 of the act of 1897 [U. S. Comp. St. 1901, p. 1687], is practically identical with the corresponding paragraph in the act of 1894, except that from the present act the word "canary" is omitted. It is admitted that canary seed is botanically a grass seed in the same sense as wheat, oats, and other cereals. Three witnesses for the importer—two of them parties to the suit, and the third one interested as an importer—testified somewhat evasively and with uncertainty that the merchandise is included under the heading of grass seed in the sense that, if a customer called for grass seed, he (the witness) would ask whether he wished canary seed, timothy seed, clover seed, or millet seed. Five witnesses for the government, apparently disinterested, testified that canary seed has never been known in the trade and commerce of this country as a grass seed, but only as a bird seed. This commercial understanding appears to accord with the popular understanding of the seed as bird or canary seed, and not grass seed. In these circumstances it must be assumed that congress, by the exclusion of the word "canary" from said paragraph, intended that canary seed should be classified for duty.

The decision of the board of appraisers is reversed.

WING et al. v. UNITED STATES.

(Circuit Court, S. D. New York. November 10, 1902.)

No. 3,336.

1. **CUSTOMS DUTIES—UNDECORATED FIRE BRICK WEIGHING OVER TEN POUNDS.**
Fire brick, not capable of decoration, over 10 pounds in weight, designed for linings to retort ovens, are dutiable, under the similitude clause of section 7 of the tariff act of 1897 [U. S. Comp. St. 1901, p. 1693], as "fire brick, weighing not more than ten pounds each, not glazed, enameled, ornamented, or decorated," under paragraph 87 [page 1632], and not under paragraph 97 [page 1633], covering decorated or undecorated articles and wares of earthy or mineral substances not specially provided for.

James R. Ely and Edward B. Whitney, for importers.
D. F. Lloyd, Asst. U. S. Atty.

TOWNSEND, Circuit Judge. The merchandise in question is fire brick, over 10 pounds in weight, designed for linings to retort coal ovens, assessed for duty under paragraph 97, Tariff Act 1897 [U. S. Comp. St. 1901, p. 1633], which provides as follows:

"(97) Articles and wares composed wholly or in chief value of earthy or mineral substances, or carbon, not specially provided for in this act, if not decorated in any manner, thirty-five per centum ad valorem; if decorated, forty-five per centum ad valorem."

It is claimed to be dutiable under the similitude clause in section 7 of the act of 1897 [U. S. Comp. St. 1901, p. 1693], as similar in material, quality, texture, and use to fire brick weighing not more than 10 pounds, under paragraph 87 of said act [page 1632], which provides as follows:

"(87) Fire-brick, weighing not more than ten pounds each, not glazed, enameled, ornamented, or decorated in any manner, one dollar and twenty-five cents per ton; glazed, enameled, ornamented, or decorated, forty-five per centum ad valorem; brick, other than fire-brick, not glazed, enameled, painted, vitrified, ornamented, or decorated in any manner, twenty-five per centum ad valorem; if glazed, enameled, painted, vitrified, ornamented, or decorated in any manner, forty-five per centum ad valorem."

The importers also claim under other paragraphs of the act, not necessary to be considered.

Counsel for the government relies upon the decision of the circuit court of appeals in the case of *Dinglestedt v. U. S.*, 33 C. C. A. 395, 91 Fed. 112, in which the court holds that said paragraph refers to articles which are susceptible of decoration. It is admitted that these articles are not susceptible of decoration, but that they are in fact fire brick similar to those weighing not more than 10 pounds. Inasmuch as both paragraphs (87 and 97) refer to articles designed for or capable of decoration, the controlling question would seem to be whether the articles are similar to either of the articles named in said paragraph. It must be held that they are more similar to fire brick weighing not more than 10 pounds each. This conclusion is strengthened by the fact that paragraph 97 only covers articles not specially provided for, while paragraph 87 contains no such clause.

The decision of the board of general appraisers is reversed.

MOSLE et al. v. BIDWELL.

(Circuit Court, S. D. New York. December 2, 1902.)

1. CUSTOMS DUTIES—TIME OF ACCRUAL—IMPORTED GOODS—DEPOSIT IN BONDED WAREHOUSES—EFFECT.

Customs Administrative Act, § 20 [U. S. Comp. St. 1901, p. 1950], provides that any merchandise deposited in bonded warehouses may be withdrawn for consumption within three years from importation, on payment of the duties and charges "to which it may be subject by law at the time of such withdrawal." *Held* that, in the absence of a statute releasing them, the duties payable at the time of withdrawal were such as accrued at the time of importation, and hence the fact that after importation from Porto Rico, but before withdrawal from the bonded warehouse, Porto Rico had become United States territory, would not relieve the importer from liability for customs duties.

Henry C. Platt, Asst. U. S. Atty., for the demurrer.

A. Henry Mosle, opposed.

WALLACE, Circuit Judge. The demurrer to the complaint presents the question whether, under section 20 of the customs administrative act (act of June 10, 1890, as amended October 1, 1890 [U. S. Comp. St. 1901, p. 1950]), the collector of the port of New York was justified in requiring payment of duties upon imported merchandise at the rate and amount to which the goods were subject at the time of their importation and deposit in the bonded warehouse, or whether he was justified only in requiring payment of such duties as they would have been subject to if imported at the date of their withdrawal for consumption. The goods consisted of sugars imported from Porto Rico. They were imported and entered for warehouse and bonded April 4, 1899. The collector liquidated the duties thereon at \$1,442.24, and it is to be assumed, in the absence of averments to the contrary, that at that time the goods were subject to duty in that amount. Subsequently, and May 6, 1899, they were withdrawn for consumption, and the collector required payment of the duties as liquidated. The complaint avers they were not subject or liable to any duty at that date, because they were not imported from a foreign country into the United States, within the meaning of any valid statute or executive order of the United States. It is conceded by counsel that this averment means that before the sugars were withdrawn for consumption, the treaty of peace between the United States and Spain having been ratified, the sugars, being importations of Porto Rico, were not dutiable, because Porto Rico was no longer a foreign country, within the meaning of the tariff acts, according to the decisions of the supreme court of the United States.

Section 20 of the customs administrative act [U. S. Comp. St. 1901, p. 1950] provides as follows:

"That any merchandise deposited in bond in any public or private warehouse may be withdrawn for consumption within three years from the date on which they were originally imported, on payment of the duties and charges to which it may be subject by law at the time of such withdrawal."

¶ 1. See Customs Duties, vol. 15, Cent. Dig. § 8.

It is not disputed that the goods were subject to duty in the amount exacted of the plaintiffs when they were deposited in bond. Being then subject to these duties, they remained so, in the absence of any treaty or statute of congress relieving them from duty. No such treaty or statute is invoked, but the argument is that the section means to allow the withdrawal of dutiable goods upon the payment of such duties as they would have been subject to if they had been imported at the time of the withdrawal. The language of the section does not require such a construction. It requires payment of the duties to which the goods are lawfully subject at the time of withdrawal. This means the duties which have become an accrued liability. Duties accrue at the date of the importation and entry of merchandise, and on that date a lien attaches to the goods and a debt for the amount accrues from the importer to the government. Warehousing is a privilege given by the statutes to which the section relates, by which, in lieu of compelling the importer to make immediate payment of his debt, he is permitted to postpone payment until he withdraws the merchandise from the warehouse for consumption. The privilege is not conferred in order that he may thereby escape by some contingency the payment of his debt. It does not contemplate giving him an advantage in that regard over other importers who pay their duties upon the entry of their goods.

Warehoused goods on withdrawal for consumption pay duties at the same rate and amount as provided by law when imported and entered, unless there is some provision of the existing tariff laws, or in subsequent legislation by congress, providing for the payment of a different rate or amount, and applicable to the goods in warehouse. The United States have never been divested of their right to the duties which accrued when the goods were imported and warehoused, because neither the treaty of peace, by any of its provisions, nor any statute passed subsequently to the one imposing the duty, has impaired or affected that right.

None of the decisions of the supreme court cited for the plaintiffs conflict with the conclusions thus reached. The observations in the opinions are to be read as addressed to the facts of the particular case under consideration by the court, and, so read, contain nothing to sanction the argument for the plaintiffs.

Judgment is ordered for the defendant.

LAVERGE v. UNITED STATES.

(Circuit Court, S. D. New York. November 6, 1902.)

No. 2,937.

1. TARIFF ACT—TAX ON COVERINGS.

Where boxes used as coverings for imported tobacco were not the usual coverings in which such tobacco was imported, but were of no value, and were thrown away or destroyed after the tobacco had been removed, they were not taxable under Act June 10, 1890, § 19 [U. S. Comp. St. 1901, p. 1924], declaring that if there be used for covering or holding imported merchandise, whether dutiable or free, any unusual

article or form, designed for use otherwise than in the bona fide transportation of such merchandise, additional duty shall be levied thereon.

Appeal by the importers from a decision of the board of general appraisers which affirmed the classification by the collector of the importation in question.

Jacob Fromme, for the importers.
Charles D. Baker, Asst. U. S. Atty.

TOWNSEND, Circuit Judge. The articles in question are boxes used as coverings for Sumatra tobacco, and were classified for duty at 35 per cent. ad valorem, under the provisions of paragraph 208, Tariff Act 1897 [U. S. Comp. St. 1901, p. 1647], on the ground that said boxes come within that portion of section 19 of the act of June 10, 1890 [U. S. Comp. St. 1901, p. 1924] which provides that "if there be used for covering or holding imported merchandise, whether dutiable or free, any unusual article or form designed for use otherwise than in the bona fide transportation of such merchandise to the United States, additional duty shall be levied and collected upon such material or article at the rate to which the same would be subject if separately imported." It is undisputed that the boxes are not the usual coverings of imported tobacco, but there is no evidence that such boxes were designed for use otherwise than in the bona fide transportation of such merchandise to the United States. In fact, the testimony shows that they are not designed for any other use, but are thrown away or cut up into kindling wood.

The decision of the board of appraisers is therefore reversed.

UNITED STATES v. BROWN et al.

(Circuit Court, S. D. New York. November 19, 1902.)

1. FALSE IMPERSONATION—REVENUE OFFICERS—INDICTMENT.

An indictment charging that defendants, unlawfully and feloniously, falsely represented themselves to be revenue officers of the United States, and in such assumed character did demand and receive \$200 from I. for a pretended violation by the latter of Act Cong. June 13, 1898 [U. S. Comp. St. 1901, p. 2293], in respect of knowingly and willfully buying washed revenue stamps, etc., and with having such washed and restored revenue stamps in possession knowingly and without lawful excuse, as prohibited by Rev. St. § 5448 [U. S. Comp. St. 1901, p. 3679], was sufficient.

2. SAME.

An indictment charging that defendants, with intent to defraud one I., unlawfully and feloniously did falsely assume and pretend to be officers and employes acting under the authority of the United States, to wit, revenue officers and employes, and in such pretended character did fraudulently demand and obtain from I. a sum of money, to wit, \$200, etc., sufficiently stated the offense described by Act April 18, 1884 (1 Supp. Rev. St. p. 425 [U. S. Comp. St. 1901, p. 3679]), prohibiting the impersonation of a United States officer, etc.

Points at issue:

The defendants, Brown and Harnett, were jointly indicted under section 5448, Rev. St. U. S. [U. S. Comp. St. 1901, p. 3679], and the act of April 18,

1884 (1 Supp. Rev. St. p. 425 [U. S. Comp. St. 1901, p. 3679]). The first count charged that the defendants, unlawfully and feloniously, falsely represented themselves to be revenue officers of the United States, and in said assumed character did demand and receive certain money, to wit, \$200, of and from one A. Isaacs, for a pretended violation by the said Isaacs of a revenue law of the United States; that is to say, of section 8 of an act of congress concerning internal revenue taxation, approved June 13, 1898 [U. S. Comp. St. 1901, p. 2293], as amended, in the respect of knowingly and willfully buying washed revenue stamps, etc. The second count was like the first, except that it charged that the defendants had in possession washed and restored revenue stamps, knowingly and without lawful excuse. The first and second counts were laid under section 5448, Rev. St. [U. S. Comp. St. 1901, p. 3679]. The third count was framed under the act of April 18, 1884 [U. S. Comp. St. 1901, p. 3679], above named. It charged that the defendants, with intent to defraud one Isaacs, unlawfully and feloniously did falsely assume and pretend to be officers and employes acting under the authority of the United States, to wit, revenue officers and employes, and in such pretended character did fraudulently demand and obtain from him, the said Isaacs, a sum of money, to wit, \$200, etc. The defendants, by their counsel, contended that the averments of the indictment were not sufficiently definite, particularly as to the designation of the sort of revenue officer meant; insisting that this should be specified, and applying the objection to all of the counts.

William S. Ball, Asst. U. S. Atty.

Charles O. Brewster (Max J. Kohler, of counsel), for defendants.

THOMAS, District Judge. The words of the indictment are technically sufficient to charge an offense under the Statutes of the United States. For the purpose of sustaining the several counts, it is not necessary to import language into either count, but it seems that it would be necessary to import such language to sustain some of the defendants' objections. What ruling may be required upon the facts as shown upon the trial need not be considered at this time.

The demurrer is overruled.

LITTLEJOHN et al. v. UNITED STATES.

UNITED STATES v. LITTLEJOHN et al.

(Circuit Court, S. D. New York. November 11, 1902.)

Nos. 3,201, 3,196.

1. CUSTOMS DUTIES—SAGO FLOUR.

Sago flour is entitled to free entry under paragraph 652 of the tariff act of 1897 [U. S. Comp. St. 1901, p. 1687] as "sago, crude," and not dutiable under paragraph 285 [U. S. Comp. St. 1901, p. 1653] as "starch," or under paragraph 20 [U. S. Comp. St. 1901, p. 1628] as a drug, or under section 6 [U. S. Comp. St. 1901, p. 1693], covering raw or unmanufactured articles not otherwise provided for.

Albert Comstock, for the importers.

Charles D. Baker, Asst. U. S. Atty.

TOWNSEND, District Judge. Upon sundry importations of sago flour, duty was assessed under the provisions of paragraph 285 of the tariff act of 1897 [U. S. Comp. St. 1901, p. 1653], for "starch, in-

cluding all preparations from whatever substance produced, fit for use as starch." The importers protested, claiming that the article was either free under various paragraphs of the act, the only one necessary now to be considered being the claim that it was free of duty as "sago, crude," under paragraph 652 of said Act [U. S. Comp. St. 1901, p. 1687], or was dutiable only at one-fourth cent per pound and 10 per cent. ad valorem under paragraph 20 [U. S. Comp. St. 1901, p. 1628], or at 10 per cent. or 20 per cent. under section 6 of said act [U. S. Comp. St. 1901, p. 1693]. Said section 6 imposes on all articles not enumerated or provided for, when raw or unmanufactured, a duty of 10 per cent., and when manufactured, in whole or in part, a duty of 20 per cent. The general appraisers sustained the claim of the importers under this last alternative, and the importers appealed, claiming free entry or lower duties. The United States also appealed from this decision.

The contention of counsel for the United States in support of its appeal that sago flour is starch, or a preparation fit for use as starch, cannot be sustained in view of the decision in the case of *In re Townsend*, 5 C. C. A. 488, 56 Fed. 222, and the decision of the supreme court in *Chew Hing Lung & Co. v. Wise*, 176 U. S. 156, 20 Sup. Ct. 320, 44 L. Ed. 412. Those cases concerned tapioca flour. It was held that tapioca flour was not fit for use as starch. From the evidence herein, it appears that the uses of sago and tapioca flour are identical. The appeal of the government is not sustained.

The importers contend that this sago flour is "sago, crude." It appears from the reports of the United States consuls, and from agricultural bulletins published by the British government, that there is a crude form of the sago pulp or pith known as "raw sago," and that it is a more crude product than sago flour. It also appears that commerce in this crude article is confined to the natives in the country where the sago grows, and it is fully proven that this raw sago has not come into this country, and would not bear transportation hereto. Sago flour is the first and only form in which the product of the sago palm is known in this country. But counsel for the government contends that it is not crude because the pulp of the sago tree has been subjected to certain processes in the foreign country before its importation here, and that in its state of importation into this country it is a completed article and ready for use. It appears, however, from undisputed testimony that the only manipulations which it undergoes in the foreign country are those which are necessary to fit it for importation, and consist in successive cleansing operations in order to get rid of the impurities which would otherwise cause fermentation.

The second claim of the government is that it is a completed article when imported, and is fit for present use. This fact might be decisive in some cases, but it is not a universal or safe test. In this case the processes of cleansing are essential to fit it for trade and commerce in this country; they neither refine nor manufacture it, but only serve to remove the impurities. Such processes are not sufficient to change its character from a crude product to a manufacture.

It is further contended that, since congress put crude sago and sago flour on the free list in former tariff acts, it must thereby have intended to designate two separate articles, and that the omission of sago flour from the free list in this act shows the intention of congress to make it subject to duty. But, inasmuch as the crude sago of Singapore is not, and cannot be, imported into this country, the words "sago, crude," in the present act, if this sago flour were excluded, would have no meaning, because they would not refer to any commercial product of sago, and no sago would be free. If, however, this term be confined to this sago flour as the first product capable of transportation, then the other manufactured products of sago or sago flour, such as "pearl sago" or "bullet," might be subject to duty under the appropriate paragraphs of said act.

It is therefore held that sago flour is entitled to free entry under paragraph 652 of the present tariff act [U. S. Comp. St. 1901, p. 1687], and the decision of the board of general appraisers is reversed.

DAISLEY v. DOUGLASS.

(Circuit Court, D. Massachusetts. December 23, 1902.)

No. 1,210.

1. LIBEL—DAMAGES—AMOUNT.

Where, in an action by a lumber dealer and building contractor for libel, he introduced evidence to prove compensatory damages, that his business loss amounted to from \$20,000 to \$24,000, resulting from the libel, but defendant in rebuttal showed that a part of the subscribers to its mercantile reports, in which the libel was published, had not withdrawn credit from plaintiff by reason of the publication, a verdict assessing plaintiff's damages at \$5,000 was excessive, and should be reduced to \$3,000.

C. F. Choate, Jr., for plaintiff.
Carver & Blodgett, for defendant.

PUTNAM, Circuit Judge. This is an action for a libel to the business of the plaintiff as a lumber dealer and building contractor. The verdict was in his favor for \$5,000, which the defendant now complains was excessive. On looking at the docket we find the verdict on a previous trial was the same. At that time, on a motion to set aside the verdict for excessive damages, we stated, in our opinion reported 107 Fed. 218, that our mind wavered, and that, as it wavered, we could not allow the motion.

There are great difficulties in the way of an attempt to formulate anything like a guiding principle in cases of this character, where, on the one hand, there is only the libel, and, on the other, nothing in the way of evidence except the fact that business has fallen off. The rest is pure matter of inference. In this respect suits for libel and slander, as we said during the trial, stand as exceptional. Of course, we were compelled to direct the jury that the verdict must be compensatory, and yet, under the circumstances, while thus technically only compensatory, the position is so akin to that of punitive

damages that it is very difficult for the court to arrive at a conclusion whether or not the jury overstepped the reasonable discretion which the law permits it to exercise. Yet, even with punitive damages, courts must see that there are limits beyond which the juries ought not to go.

At the previous trial it was plain that there were certain computations which the jury might make, and which should have limited them as to one element of damages. The evidence as to that was practically the same as it is now, proving a loss of business from \$20,000 to \$24,000 on the whole, all within two years from the time of the libel. Of course, the jury could not allow for this more than reasonable estimated profits on that amount of business, having, however, the fact in view that, if one's business, like the plaintiff's, falls off a certain percentage, it still carries with it, ordinarily, the same cost for office work, teams, and routine expenses which it does with the full volume of transactions; so that a partial loss ordinarily represents something more than the mere average profit on the goods he sells.

It seemed to us then, and it seems to us now, that the jury, assuming that it concluded that the loss of business proven was the consequence of the libel, might well have awarded as the damage thus proved from \$2,000 to \$3,000. Beyond that it could not have gone, unless it saw, in the general attitude of the case, a probability of damages ensuing not proven in this relatively direct way; that is to say, unless it saw a probability of a continuing diminution of credit, cropping out at unforeseen times, which would naturally result in a further loss of business. It was this unexplored field which led the court to make the remark at the former trial that its mind wavered, and that it, therefore, could not interfere with the verdict. At this present time the defendant has made a much stronger case in that respect than he did at the first trial. He has made a case so much stronger that it affects decidedly the views which the court takes of the question of damages. The defendant has now introduced witnesses who show that all, or nearly all, parties who were subscribers to the defendant's reports to whom the libel was published, did not withdraw credit after the publication. He has met in that way, not with absolute certainty, but with as much certainty as is possible in a court of law, the suggestion that the jury might be justified in going into this unexplored field, as we describe it.

As the case now stands, it seems to us that the jury was not justified in rendering a verdict for a sum substantially more than what might be estimated as the diminution of the plaintiff's net profits arising out of the proved loss of business. The court repeats its observation that, where the rules of law are so peculiar as they are in cases of this character, it is difficult for us to revise the verdict of a jury. Nevertheless, under all the circumstances, we are of the opinion that \$3,000 must be the extreme to which the jury could justly have gone; and the order will be that, unless the plaintiff remits all damages in excess of that amount, there will be a new trial.

In re EDSON.

(District Court, D. Vermont. December 8, 1902.)

1. NOTES—LIABILITY OF INDORSER.

A note payable to the order of the maker, when indorsed by him, becomes a negotiable instrument; and a second indorser for accommodation becomes a party to such instrument, with the liabilities and immunities of an indorser of commercial paper, and his liability can only be fixed by protest and notice in due form.

2. BANKRUPTCY—PROVABLE CLAIMS—NOTES UNLAWFULLY DISCOUNTED BY BANK CASHIER.

Where the cashier of a national bank, without the knowledge and against the orders of the other officers, discounted for the maker notes far in excess of the amount which the bank could legally loan to one person, and beyond the ability of the maker or indorser of such notes to pay, the facts that he was prosecuted and sentenced to imprisonment for misapplying the funds of the bank, and the maker of the notes for aiding and assisting him, and that the receiver for the bank sued and recovered on the cashier's bond the amount of the penalty therein, do not affect the validity of the notes, nor the bank's ownership thereof; and the receiver may prove the same in bankruptcy against the estate of the indorser, where proper steps were taken to fix his liability thereon.

In Bankruptcy. On review of the allowance by the referee of the claim of D. D. Muir, receiver of the Merchants' National Bank, on 78 notes, amounting to \$139,850, indorsed by the bankrupt.

Geo. L. Rice, for receiver.

Fred M. Butler and Thomas W. Moloney, for trustee.

Chas. L. Howe, for creditors.

WHEELER, District Judge. These notes were made by M. A. McClure, payable to himself or order, and indorsed by him in blank, and after him, for his accommodation, by the bankrupt; and were respectively discounted by the cashier of the bank without the knowledge and contrary to the directions of the other officers, and the avails went to McClure. The cashier, on a plea of guilty, has been convicted and sentenced for misapplying the funds of the bank by these transactions; and McClure, on a verdict of guilty, has been convicted and sentenced for aiding and assisting the cashier in these misapplications; and the receiver has recovered judgment in this court against the United States Fidelity & Guaranty Company for the penalty of a bond of indemnity of \$20,000 against fraud and dishonesty of the cashier on account of these losses.

One principal question made is as to the relation of the bankrupt to the notes. As to this, it is considered that when the notes were made they were merely promises of the maker to himself, and amounted to no undertaking at all; but when they were indorsed by him they became negotiable instruments, payable to his indorsee, and when the bankrupt indorsed after him the bankrupt became a party to the notes, as an indorser, with the liabilities and immunities of an indorser of negotiable paper. His position as such entitled him to due notice of demand and nonpayment before his liability would become fixed; and, as to the notes of the nonpayment of which no notice was given, no liability as indorser became fixed

upon him. He cannot, in any view, be held liable for the money passed, for he received none. The notes on which no notice of nonpayment was given to the bankrupt are disallowed.

The transactions are said, in behalf of the trustee, to have been illegal; and so repudiated by the prosecution of the cashier and McClure, and, by pursuing the surety company for the misappropriations of the cashier, that there was either no liability of the bankrupt on any of the notes, or it was lost by the election of those remedies. There was no illegality about the conduct of the bank itself that would invalidate the notes. The excess of the limit allowed by the loans to one person would not have that effect. The prosecution of the cashier and of McClure was by the law officers of the United States, and not by or in behalf of the bank. The notes were all genuine, and were always in and the property of the bank, after they were taken by the cashier, although the other officers of the bank did not know it. The criminality of the cashier consisted in secretly letting the funds of the bank go on these notes to such an amount that there could be no hope of their payment, thereby resulting in a misapplication, and not in taking notes that were not genuine and valid. The criminality of McClure consisted in assisting the cashier in thus depleting the assets of the bank by these means. The loss of the bank was not through any infirmity of the paper, but on account of the irresponsibility of the maker and indorser. The bank did not recover against the surety company on the ground that the cashier took notes that were invalid, but that they were valueless. The bank did not set up invalidity then where it does validity now. Its position has been consistent all the while. The notes were always valid against the maker and indorser, before as well as after its general officers knew of them. It had nothing to do to validate them after discovery of them. It has had no election to make in respect to them, and has made none. The protested notes, which amount to \$45,700, are allowed.

Report accepted, and allowance modified thereon to protested notes, amounting to \$45,700.

DICKSON MFG. CO. v. AMERICAN LOCOMOTIVE CO.

(Circuit Court, M. D. Pennsylvania. December 19, 1902.)

No. 1.

1. ARBITRATION—PROVISION IN CONTRACT—CONDITION OF ACTION.

Provision for arbitration in a bill of sale, following after an express agreement to pay, does not, on the arising of a dispute as to whether, under the contract, certain expenses are to be taken as an element of "cost to vendor," make an award of arbitrators a condition precedent to a right of action.

2. ARBITRATION—REVOKING AGREEMENT.

Provision in an arbitration clause in a bill of sale that failure of either party to appoint an arbitrator shall authorize the other to make an ap-

¶ 1. See Arbitration and Award, vol. 4, Cent. Dig. § 30.

pointment for the one in default does not prevent a revocation of the agreement for arbitration.

Alfred Hand and William Hand, for plaintiff.
Woodward, Darling & Woodward, for defendant.

ACHESON, Circuit Judge. Whether the two papers—the primary agreement of June 1 and the bill of sale of June 20, 1901—be read together or separately, the provision for arbitration embraces all disputes, of whatsoever character, that might thereafter arise between the parties touching their contract. The provision in paragraph numbered 7 of the agreement of June 1st (called the "Option Contract") is this:

"In case any difference or dispute shall arise between the parties hereto in respect to the interpretation or carrying out of this instrument or any of its provisions, including the cost of materials, supplies, product finished or in process, such dispute or difference shall be settled as follows: Each party hereto shall appoint one arbitrator or appraiser, and the two so chosen shall select a third. The written award or decision of a majority of such arbitrators shall be final and conclusive."

The paper of June 20th (the bill of sale) provides as follows:

"And said parties further mutually agree for themselves, their heirs, successors, representatives, and assigns, respectively, that any difference or dispute arising in respect to the matters of this paragraph shall be adjusted and settled by arbitration or appraisal and award, as provided in the paragraph numbered 7 of the option contract aforesaid."

If the operative effect of the latter provision is at all less than that of the former provision, it is only because the original agreement had been carried out in part. Certainly, as to everything yet remaining to be done on the one side or the other, the provision for arbitration expressed in the paper of June 20th is as comprehensive as is the seventh paragraph of the agreement of June 1st. No arbitrator or appraiser is named or designated in either of the papers. The arbitrators are to be chosen or selected thereafter, should any future difference or dispute arise. Plainly, the stipulation for arbitration relied on to defeat this action is an attempt to oust the jurisdiction of the courts to determine the rights of the parties.

Upon an examination of the authorities submitted to me, I am satisfied that the decisions of the courts, both of New York and Pennsylvania, are against giving to the stipulation the effect claimed for it by the defendant. But the ruling of the supreme court in *Hamilton v. Insurance Co.*, 137 U. S. 370, 385, 11 Sup. Ct. 133, 34 L. Ed. 708, is decisive against this defense. It was there held that a provision in a policy of fire insurance that "in case differences shall arise touching any loss or damage, after proof thereof has been received in due form, the matter shall, at the written request of either party, be submitted to impartial arbitrators, whose award in writing shall be binding on the parties as to the amount of such loss or damage, but shall not decide the liability of the company under this policy," cannot be pleaded in bar of an action on the policy; there being no provision in the policy postponing the right to sue until after an award. In the instruments under consideration there is no provision whatever postponing the right to sue until after an award. Moreover, the

stipulation for arbitration follows after an express promise to pay. These two stipulations are distinct and independent. The stipulation to refer is collateral. Neither by express stipulation nor by necessary implication is an award of arbitrators made a condition precedent to a right of action here. The following quotation from the opinion in *Hamilton v. Insurance Co.*, supra, is apt:

"But when no such condition is expressed in the contract, or necessarily to be implied from its terms, it is equally well settled that the agreement for submitting the amount to arbitration is collateral and independent, and that a breach of this agreement, while it will support a separate action, cannot be pleaded in bar to an action on the principal contract."

It is proper for me to state that the dispute which has arisen between these parties does not concern a matter of mere valuation or appraisal. It involves the interpretation of their agreement. It requires the determination of the meaning of the words "cost to vendor of the materials, supplies, and product finished or in process," as used by the parties in their contract. The parties differ radically as to what the phrase "cost to vendor" embraces. The difference between them raises the question whether, upon a true construction of the contract, general shop expenses are to be taken as an element of "cost to vendor."

I cannot concur in the view urged in behalf of the defendant, that the provision in the arbitration clause here that the failure of either party to appoint an arbitrator shall authorize the other party to make an appointment for the one in default, was the grant of a power coupled with an interest, and therefore irrevocable. As it is not in the power of parties to a contract to oust the courts of their jurisdiction, the whole clause for constituting the board of arbitrators necessarily fell when the plaintiff revoked the submission. In such a case as this even an express covenant not to revoke would not prevent a revocation. In its very nature, such an agreement for arbitration as this is revocable. That the plaintiff did duly revoke the agreement for arbitration is clear. The verbal notice to that effect given by the plaintiff's counsel was followed by the plaintiff's letter of February 15, 1902, to the defendant, containing an explicit revocation. Then, on February 17, 1902, before any board of arbitrators had been constituted, this suit was brought; and finally, on March 7, 1902, the plaintiff gave written notice to the arbitrators appointed ex parte that the agreement to arbitrate had been revoked, and suit brought.

The defense based on the arbitration clause will be overruled.

FEIL v. WABASH R. CO.

(Circuit Court, E. D. Missouri, N. D. June 10, 1902.)

1. SECURITY FOR COSTS—RIGHT TO SUE AS POOR PERSON—EFFECT OF CONTRACT TO PAY ATTORNEY CONTINGENT FEE.

A plaintiff in a federal court, who has made a contract with her attorney to prosecute her case for a contingent fee, in a state where the statute recognizes such contracts as valid, and gives the attorney a special lien for his fee on the judgment recovered, represents as plaintiff not

only her own interest, but that of her attorney, as trustee, and cannot sue as a poor person under the provisions of Act July 20, 1892 (U. S. Comp. St. 1901, p. 706), unless it is shown that all persons beneficially interested in the action come within the terms of the act.

On Motion for Security for Costs.

Thomas H. Bacon and J. D. Dale, for plaintiff.

Geo. S. Grover and Geo. A. Mahan, for defendant.

ADAMS, District Judge. This is a motion for security for costs, and the only question for determination is whether plaintiff is entitled to sue as a poor person, under the provisions of the act of July 20, 1892 (27 Stat. 252 [U. S. Comp. St. 1901, p. 706]), when it appears that she has made a contract with her attorney to prosecute her suit for a fee contingent upon recovery. Such contracts, unless they impose an obligation upon the attorneys to pay the costs and expenses of litigation, are not champertous. *Duke v. Harper*, 66 Mo. 51, 37 Am. Rep. 314, and cases cited. But when they are once made the attorneys have a pecuniary interest in the cause of action. Under the statutes of Missouri (Sess. Acts 1901, p. 46) such contracts have received legislative recognition, and the proceeds of the claim or cause of action sued on have been made the subject of a special lien in favor of attorneys to secure them in the interest acquired by their contracts. In such cases a plaintiff represents not only her own interest, but also that of attorneys in the case. She sues for herself and as trustee for others. She may be poor, and, standing alone, might be entitled to the beneficent provisions of the act of 1892; but in her representative capacity she cannot be poor within the meaning of that act, unless the beneficiaries whom she represents are also. In my opinion, no petition to sue as a poor person can avail unless it discloses that all the beneficiaries, as well as the nominal plaintiff, come within the purview of the act. The petition to sue as a poor person is accordingly denied, and the motion for security for costs is sustained. Plaintiff will be required, on or before the first day of the next term of this court, to make the usual deposit of \$50, or to give a cost bond, with sureties to be approved by the court, in the penal sum of \$200.

POLK et al. v. MUTUAL RESERVE FUND LIFE ASS'N et al.

(Circuit Court, S. D. New York. December 24, 1902.)

1. CORPORATIONS—SUIT FOR DISSOLUTION—SUFFICIENCY OF BILL.

In a bill by members of an insurance association for its dissolution, it is essential to allege the insolvency of the corporation, and that complainants have an interest in the fund, and such allegations must be explicit and based on facts pleaded.

In Equity. Suit by thirteen members of an insurance association to wind up its affairs and for the appointment of a receiver. On demurrer to bill.

William Hepburn Russell and D. L. Snodgrass, for complainants.
Frank R. Lawrence and Frank H. Platt, for defendants.

COXE, Circuit Judge. The bill covers 88 printed pages. That it is unnecessarily prolix was admitted at the argument. That it is tautological, uncertain, contradictory and verbose cannot be successfully disputed. It bears evidence of having been hastily prepared. It abounds in argument, it pleads evidence and conclusions of law, and it contains numerous allegations of wrongdoing which seem to be inconsequential; at least their relevancy to the supposed cause of action has not been pointed out. That the bill can, with advantage, be reduced to one-third its present dimensions must be obvious to any one who has read it critically. The demurrer challenges the jurisdiction of the court and alleges want of equity. The other grounds of demurrer to the bill in its entirety are that the complainants are not shown to have any interest in the subject-matter of the controversy and that an action of this character, if maintainable at all, must be instituted by the attorney general of the state. There are also 22 special demurrers aimed at various allegations of the bill which are alleged to be irrelevant, scandalous, uncertain and impertinent. After giving the matter careful consideration I have determined that the proper course to pursue is to sustain the demurrer with leave to the complainants to file an amended bill. I am not prepared at this time to assert that it will be impossible for the complainants to formulate a cause of action and, therefore, I deem it wise and prudent to refrain as far as possible from a discussion of the numerous questions argued in the briefs. A decision of these questions now may seriously complicate the controversy should they be again presented upon different or additional facts. It suffices to say that after a conscientious effort to understand the bill I am of the opinion that it cannot be maintained in its present form. It is clear that the nature and extent of the complainants' interest should be stated and that the bill should be purged of indeterminate and inconsistent allegations.

In actions of this character there can be no dispute regarding the following propositions: It is necessary to allege, first, the insolvency of the corporation, and, second, that the complainants have an interest in the fund. These allegations must be explicit and based on facts. In the present bill they are neither explicit nor are they based on facts. The initial defect in the bill is the failure to allege the contracts which determine the reciprocal rights of the parties. There is nothing but inference and conjecture to show that the complainants would have an interest in the fund should their action succeed; certainly there is nothing to show the extent of their interest. These agreements are the foundation upon which the right to relief rests, and yet the court is left in ignorance as to their terms. It is not enough to aver that the complainants were accepted as members of the association with all the privileges, interests, duties and obligations of such membership, or that they were accepted upon the same terms as other members; without knowing what the obligations of membership are or on what terms the other members were accepted. The naked allegation of insolvency is frequently made in the bill, but the facts to support it are contradictory and inadequate. In other parts of the bill facts are given and statements are made which lead to the conclusion that the association is in a perfectly solvent

condition. It is enough to say that I am at a loss to determine, after weighing all these statements and examining the exhibits attached to the bill, whether the association is solvent or insolvent. I certainly would hesitate to make a finding of insolvency based upon these allegations alone assuming all the facts stated therein to be true.

The demurrer is allowed, but with leave to complainants to amend the bill within 40 days.

THE BUENOS AIRES.

THE JOHN A. BOUKER.

THE N. Y. CENTRAL NO. 8.

(District Court, E. D. New York. November 29, 1902.)

1. COLLISION—VESSELS LYING AT END OF PIER—NEW YORK STATUTE.

Under the New York statute making it unlawful for a vessel to lie at the end of a pier, where she is liable to be injured by vessels entering the adjacent slips, under penalty of being denied recovery for such an injury, the fact that a vessel is so lying does not preclude a recovery for an injury caused by another vessel which is not at the time entering or leaving an adjacent dock.

2. SAME.

In clearing a slip in East river for a steamship, tugs placed a barge and canal boat outside of three other boats at the end of the pier below. The steamship, which was lying 400 feet off the ends of the piers, headed up stream, having decided not to dock at that time, swung around to go down the river, and in doing so struck the boats at the end of the pier, causing their injury. *Held*, that the tugs were not chargeable with fault contributing to the injury, which was due solely to the fault of the steamship in negligently going about as she did, instead of moving ahead before turning.

In Admiralty. Suit for collision.

James J. Macklin, for libelant.

Wing, Putnam & Burlingham (Mr. Forrester, of counsel), for the Bouker.

Butler, Notman, Joline & Mynderse (Mr. Brown, of counsel), for the N. Y. Central No. 8.

Convers & Kirilin (Mr. Kirilin, of counsel), for the Buenos Aires.

THOMAS, District Judge. An attempt to dock the steamship Buenos Aires on the upper side of pier 10 in the East river was abandoned after waiting some time for the slip to be cleared, the ebb tide meantime becoming too strong to permit its safe accomplishment, and thereupon the steamship, which was headed directly up the river, and several hundred feet off from the piers, ported to go about in the river upon her return to her anchorage in the North river, when her port quarter came in contact with a New York Central barge lying outside four other boats at the end of pier 9, causing damage to the Terrell, the fourth boat, whose owner brings the present action. The claimant of the Buenos Aires controlled and was entitled to the use of pier 10 and half the slip on each side of it. Before the steamship came up, the canal boat Terrell was lying in the slip north of pier

10, and the agent for the steamship company asked the harbor master that she be placed elsewhere. The latter ordered that she be taken to pier 6, where canal boats are usually stored. Thereupon the steamtug Bouker was engaged to take the Terrell to pier 6. The captain and mate of the Bouker state that the agent of the steamship company ordered the Bouker to get the Terrell out of the way, and mentioned pier 9 as a suitable place. The Bouker did take the Terrell, and left her outside of three boats at the end of pier 9, over which the steamship company had no jurisdiction; the captain of the Bouker stating to the Terrell's master that he would go back and get an elevator at pier 10, and upon returning would take the Terrell and carry her to pier 6. The Bouker carried the elevator to pier 6, but did not return for the Terrell. Hence, as regards the Terrell, the facts are that she was placed at pier 9 by the Bouker, and left with the expressed intention on the part of the captain of the Bouker to leave her no longer than would be necessary to go back to the slip above pier 10 and place the elevator. Later the New York Central tug No. 8 went to pier 11, outside of which a New York Central barge was lying, having been summoned to put her in the slip above pier 10 to load a schooner. Tug No. 8 found that the slip was crowded, and that she could not enter, and gave evidence that somebody, in apparent authority on the dock, suggested that the barge be placed at pier 9. Palmer, the agent in charge of the dock, states that he told the New York Central tug No. 8 not to get in the way, but did not direct that the barge should be placed at pier 9. It is claimed by the Buenos Aires that it was gross negligence on the part of the tug to place the New York Central barge and the Terrell at the end of pier 9 at the time when the Buenos Aires was seeking to make her dock, and was so close to pier 9. The statute makes it unlawful for a vessel to lie at the end of a pier, where she is liable to be injured by vessels entering the adjacent dock or pier, and the penalty is failure to recover damages for injury caused by any vessel entering or leaving any adjacent pier.

It will be observed that the statute makes it unlawful for vessels to obstruct the waters by lying at the end of wharves, except at their own risk of injury from other vessels entering or leaving any adjacent dock or pier. The injury in the present case did not arise while the Buenos Aires was entering or leaving the dock or pier. It appears from the evidence of the pilot of the steamship that the Terrell was in position when he arrived; that he took up his position headed directly up the river and 400 feet off from the pier, and that he remained in such position until he was prepared to go upstream and go around in the river; that he had determined, on account of the strength of the tide, not to dock his vessel, even before he saw anything of the barge; and that the accident occurred while he was swinging off into the river. Manifestly the statute has no application. Nor does it appear that at the time when the New York Central barge was placed outside of the Terrell the Buenos Aires was in such proximity as to make her presence there dangerous to herself or others, unless the Buenos Aires should enter the slip. Surely, the presence of the barge outside of the Terrell did not negligently

obstruct the Buenos Aires, in her attempt to go up the stream, round about into the North river, and go to anchorage, as she had determined to do it before the pilot even saw her. She had the usual opportunity to use the river, and simply came too close to the barge at the end of pier 10 in going about.

These views lead to the direction of a decree against the Buenos Aires alone, and a dismissal of the libel as to the other tugs.

WEST v. UNITED STATES.

(Circuit Court, S. D. New York. November 6, 1902.)

No. 2,893.

1. CUSTOMS DUTIES—GINGER ALE.

Ginger ale in bottles, imported when the tariff act of 1894 was in effect, was liable for duty, under paragraph 248 of the act, for 20 per cent. ad valorem, but was not liable for duty on the cost of corking, wiring, labeling, and capping, in accordance with Act June 10, 1890, § 19 [U. S. Comp. St. 1901, p. 1924].

Appeal by the importer from a decision of the board of general appraisers which affirmed the classification by the collector of the importation in question.

Hartley & Coleman, for appellant.
Charles D. Baker, Asst. U. S. Atty.

TOWNSEND, Circuit Judge. The merchandise in question comprises ginger ale in bottles, imported when the tariff act of 1894 was in effect. Paragraph 248 of said act provides as follows:

"248. Ginger ale or ginger beer, twenty per centum ad valorem, but no separate or additional duty shall be assessed on the bottles."

The collector, however, assessed duty at 20 per cent. ad valorem, not only upon the ginger ale, but upon the cost of corking, wiring, labeling, and capping, in accordance with the provisions of section 19, Act June 10, 1890 [U. S. Comp. St. 1901, p. 1924], as charges on the ginger ale. Said section provides as follows:

"Sec. 19. That whenever imported merchandise is subject to an ad valorem rate of duty, or to a duty based upon or regulated in any manner by the value thereof, the duty shall be assessed upon the actual market value or wholesale price of such merchandise as bought and sold in usual wholesale quantities, * * * including the value of all cartons, cases, crates, boxes, sacks, and coverings of any kind, and all other costs, charges, and expenses incident to placing the merchandise in condition, packed ready for shipment to the United States, and if there be used for covering or holding imported merchandise, whether dutiable or free, any unusual article or form designed for use otherwise than in the bona fide transportation of such merchandise to the United States, additional duty shall be levied and collected upon such material or article at the rate to which the same would be subject if separately imported. That the words 'value' or, 'actual market value' whenever used in this act or in any law relating to the appraisement of imported merchandise shall be construed to mean the actual market value or wholesale price as defined in this section."

It appears from the opinion of the board that they had formerly decided this question in favor of the importer, but were constrained

in this case to overrule their previous decision, and to reach a contrary conclusion by virtue of the decision in *U. S. v. Keane* (C. C.) 84 Fed. 330. Since said decision was rendered, however, the same question has been passed upon by the supreme court of the United States in the case of *Schlitz Brewing Co. v. U. S.*, 181 U. S. 584, 21 Sup. Ct. 740, 45 L. Ed. 1013. The reasoning and conclusions in that case are applicable to the question at issue here.

The decision of the board of appraisers is reversed.

PISTONER v. AMERICAN CAN CO.

(Circuit Court, E. D. Pennsylvania. December 11, 1902.)

No. 60.

1. MASTER AND SERVANT—FELLOW SERVANTS.

A foreman of a workroom in a factory is not, by reason of such employment, a vice principal and representative of the employing corporation with respect to other workmen in such room.

At Law. On motion for new trial.

H. J. Rebman, Glenn C. Mead, and J. G. Gordon, for plaintiff.

R. C. Dale, for defendant.

DALLAS, Circuit Judge. Two grounds are urged in support of the plaintiff's motion for a new trial, which should not be confounded, but be separately considered. It is contended, first, that a certain John Markowitz was not a fellow servant of the plaintiff, but was a vice principal; and, second, that the injury suffered by the plaintiff resulted from the failure of the defendant to maintain reasonably safe machinery for use by the plaintiff.

1. Upon the first of these questions I am still of the opinion which I entertained upon the trial. I think the court would not have been justified in holding that Markowitz, by reason of his employment as foreman of the room in which the accident occurred, was to be regarded as representative of the defendant company itself.

2. The duty which the defendant owed to the plaintiff, to exercise such care as an ordinarily prudent man would exercise to keep its machinery in safe condition, imposed a responsibility which it could not shift to Markowitz or to any one. The obligation was absolute. Had it been fulfilled? This question was submitted to the jury, and, in my opinion, its submission, and the jury's finding upon it, were both correct.

The motion for a new trial is denied.

¶ 1. Who are fellow servants, see notes to *Northern Pac. R. Co. v. Smith*, 8 C. C. A. 668; *Canadian Pac. Ry. Co. v. Johnson*, 9 C. C. A. 596; *Fluppen v. Kimball*, 31 C. C. A. 286.

See *Master and Servant*, vol. 34, Cent. Dig. § 427.

CITY OF CHICAGO v. PENNSYLVANIA CO.*

(Circuit Court of Appeals, Seventh Circuit. February 28, 1902.)

No. 735.

1. MUNICIPAL CORPORATIONS—LIABILITY FOR PROPERTY DESTROYED BY MOB.
A city may be held liable for the destruction or injury of property, in consequence of a mob or riot therein, where such liability is imposed by statute; and it is no defense to an action for its enforcement that the city exercised all its power to prevent the loss, or that the state and federal governments were also engaged in protecting the property.
2. SAME—ACTION FOR DAMAGES—EVIDENCE CONSIDERED.
Evidence examined, and held to sustain the finding of a jury that property was destroyed in consequence of a mob during the railway strike of 1894 in Chicago, within the meaning of the Illinois statute, so as to render the city liable therefor.
3. SAME—EVIDENCE.
In an action against a city to recover for property destroyed and injured in consequence of a mob or riot, a proclamation issued by the mayor calling for troops to suppress the riot, telegrams sent by him to the governor, and similar official acts are admissible in evidence to show the conditions existing at the time the property was destroyed.
4. BAILMENT—INTEREST OF BAILEE—RIGHT TO SUE FOR INJURY OF PROPERTY.
A railroad company has such property in cars which it holds under lease, and in cars of other companies temporarily in its possession and use as bailee as a common carrier, as will support an action for their wrongful injury or destruction.

In Error to the Circuit Court of the United States for the Northern Division of the Northern District of Illinois.

T. J. Sutherland, for plaintiff in error.

George Willard, for defendant in error.

Before JENKINS and GROSSCUP, Circuit Judges, and BUNN, District Judge.

BUNN, District Judge. This is an action at law, brought by the Pennsylvania Company against the city of Chicago, to recover damages caused to its property in that city, growing out of the riots there in July, 1894. The declaration sets out that on July 6, 1894, the plaintiff was the owner of certain railroad property and equipments within the city, giving a full description, and that in consequence of a certain mob or mobs, riot or riots, each of which was then and there composed of 12 or more persons within the territorial limits of said city, a large amount of such property and equipment was injured and destroyed, including seven box cars of the value of \$3,745, six stock cars of the value of \$5,000, four box cars of the value of \$1,000, one refrigerator car of the value of \$1,000, injured to the extent of \$140. Ten of said stock cars of the value of \$3,000 were injured to the extent of \$1,400. Thirteen of said box cars of the value of \$3,500 were injured to the extent of \$1,820. Various other allegations are contained in the declaration, alleging damage by fire

* Rehearing denied May 7, 1902.

¶ 1. See Counties, vol. 13, Cent. Dig. § 213; Municipal Corporations, vol. 36, Cent. Dig. § 1558.

and otherwise to buildings, cross-ties, targets, yardmaster's office, passenger station at or near Fifty-First street, milk trains, railroad track of the length of 25 miles and of the value of \$25,000 obstructed by derailment of cars, etc., and injured to the extent of \$600. One lot of merchandise of the value of \$10,000 is alleged to have been injured to the extent of \$5,000. A bill of particulars was filed with the declaration, giving in detail the property injured and the extent and place of loss, which foots up at the sum of \$16,010.44; and the plaintiff claims damages in the sum of \$30,000. The statute of the state of Illinois under which the action is brought, and without which no action could be maintained, is substantially as follows:

"Whenever any building or other real or personal property, except property in transit, shall be destroyed or injured in consequence of any mob or riot composed of twelve or more persons, the city, or if not in a city, then the county in which such property was destroyed, shall be liable to an action by or in behalf of the party whose property was thus destroyed or injured, for three-fourths of the damages sustained by reason thereof.

"No person or incorporation shall be entitled to recover in any such action if it shall appear on the trial thereof that such destruction or injury of property was occasioned, or in any way aided, sanctioned, or permitted by the carelessness, neglect, or wrongful act of such person or corporation; nor shall any person or corporation be entitled to recover any damages for any destruction or injury of property as aforesaid, unless such party shall have used all reasonable diligence to prevent such damage.

"No action shall be maintained under the provisions of this act, by any person or corporation whose property shall have been destroyed or injured as aforesaid, unless notice of claim for damages be presented to such city or county within thirty days after such loss or damage occurs and such action shall be brought within twelve months after such destruction or injury occurs."

Several special pleas were put in to the declaration, intended to exempt the city from liability, as that the city exercised all its power to prevent the loss; that the United States and the state of Illinois, as well as the city of Chicago, were all interested and engaged in protecting the property so lost; and that the city had not property or funds except such as could be raised by taxation to pay the loss. A demurrer to these pleas was sustained, and the pleas overruled, the court holding the city liable for the damage charged, done by the mob, upon the adjudged cases,—citing *Underhill v. City of Manchester*, 45 N. H. 214; *Darlington v. City of New York*, 31 N. Y. 164, 88 Am. Dec. 248; *Allegheny Co. v. Gibson*, 90 Pa. 397, 35 Am. Rep. 670; *Cooley, Tax'n*, 480; *Louisiana v. City of New Orleans*, 109 U. S. 285, 3 Sup. Ct. 211, 27 L. Ed. 936. The law as determined by the court below on the question of liability in a proper case seems to be well settled by these and other decisions. The case was tried before a jury, and a verdict rendered in favor of the plaintiff for the sum of \$2,792.58, upon which judgment was rendered which the writ of error is brought to reverse.

The case seems to have been carefully tried, and at the close of the trial the jury were fully and fairly instructed upon all the issues. We have been at the trouble of reading the evidence, as many of the assignments of error seemed to be based upon objections to the sufficiency or competency of the testimony. But we find no error in the record. The evidence of the plaintiff seems to be full and

abundant, even conclusive, upon all the material issues, and the verdict of the jury was certainly moderate in view of evidence of damage. There are 69 assignments of error, as though it were intended to make up in number what is apparently lacking in force. But, if counsel will incur the record with such an apparently needless number of exceptions and assignments of error, it can hardly be expected that the court should consider them all, in detail or otherwise, except in a collective way. We shall notice such as were mainly argued and relied upon on the hearing.

It is assigned first as error that the declaration does not state a cause of action, and that for that reason the verdict and judgment are against the law. We think this question was correctly decided on the demurrer to the pleas.

It is objected that it was not shown on the trial that the plaintiff's property was destroyed in consequence of a mob. It is hard to see what could be asked for in the case on this point more than was produced in evidence. There were dozens of eyewitnesses testifying to the riot and the overturning and destruction of cars and other property by fire and otherwise in consequence thereof. The mob was such for several days that the mayor called on the governor by telegram for troops to subdue it by force. Troops were called out, both state and national, to put down the riot and stay the destruction of property, and but for these troops it is difficult to see that the ravages of the mob could have been stayed. A few examples of testimony from many witnesses who were present will suffice to show the slight ground there is for this assignment.

Chas. D. Law, connected with the company since 1873 and superintendent of the Western division of the Ft. Wayne road, between Crestline and Chicago, testified that he was in Chicago during the forepart of July, 1894. "The 6th of July, in the morning about 9 o'clock," he says, "I noticed crowds beginning to gather inside of the yard at Fifty-First street. I then telegraphed to our headquarters in town asking for some protection, either police or military. I received an answer that a company of regulars, the Fifteenth or Sixteenth Regulars, which were then on duty at the Rock Island crossing at Fifty-First street, would be ordered by General Miles, or the commanding officer, at least, to report to me at Fifty-First street. I went over to the Rock Island tracks as quickly as I could, and found the captain in command, showed him this message, and found that he had not yet received his instructions; but, without waiting for them, he called his men together and we marched over from the Rock Island tracks to our tracks. We marched down Forty-Seventh street, and then down the track to Fifty-First street. When we reached Fifty-First street there were, I should say, at least 300 people congregated just inside of the fence on our ground, at least on the street crossing adjacent to it. Capt. Conrad, who was in command of the company, stepped out and informed his men first to cross the street, and he stepped in front and ordered the crowd to disperse. * * * He made another attempt to disperse them, but they laughed and hooted and made quite a good deal of noise. He then directed the lieutenant in charge to charge the crowd, which he did, and drove

them back outside the fence which marks the limits of our property on the east. Then the troops came back to their original position, which was about half way between the main track and the easterly line of our property, and still preserved that line, full company front, across Fifty-First street. By the time they had returned to their first position the crowd had surged in upon the company's property, and the captain again spoke to them, going out in front of his company, and talked to them, told them to go away, with the same result as before, and also the same result as to the charge. They charged the crowd a second time with bayonets. After that charge they stayed outside. Then I called the captain's attention to the necessity of placing guards at different points along the yards to keep unauthorized persons away, and before we had an opportunity to get any of these guards stationed, a fire broke out among the cars immediately south of Fifty-First street and east of our tracks, east of our main tracks,—what we called the 'east yard.' Side tracks are laid east of the main tracks. I ran down to Fifty-Fifth street to get some engines there to pull the cars away from there,—cars that were south of the burning cars,—pull them away to set them in other parts of the yard so the fire would not communicate to those cars. About the time I got to the south end of the yard the city fire department arrived and was playing on this fire. My recollection is that there were 25 or 30 cars damaged or burned in that fire. That was the 6th of July in the afternoon. I saw a crowd of men surrounding several cars immediately north of Fifty-First street on the side track and throwing them over,—throwing the boxes of the cars off of the tracks. This was on our right of way. I cannot say how many cars. I can recall I saw three thrown over. I cannot say that I saw more than three. I should say there were 25 or 30 persons in the crowd. Then on the west side of our main tracks, what we call our 'west end,' another crowd of about 20 people pushed a car that was standing on one of these yard tracks out over the lead track,—that is the track which connects the switch track, so called, in the yard, with the main tracks,—out over the lead until it got out and fouled the main track, to block that track. They pushed it from the side track onto the main track. That car stayed there. While I stayed there, there were at least three cars that I saw overturned. After that I saw a number of cars that had been overturned, but I did not see the operation performed. As to these overturned cars, I ordered the wrecking car out with a crew to set them up along the tracks, to pick these cars up, take them off the main tracks, and replace them upon their trucks. That was done during the afternoon. The same operation had to be performed again that night on cars that were overturned. That is all I saw on that day, excepting I saw fires started from one or two little shanties that we had, which were burned. I saw fires as they started from one or two little shanties, the yardmaster's office at Forty-Seventh street, and a little building we had at Fifty-First street, which was used by the crossing watchman and also by passengers who came to wait for our accommodation trains. I saw the fires start, and saw them burning from a distance; but I was not there. I did not see anybody around

them, and did not see anybody set fire to them. I saw the fires burning. * * * The cars which had been upset, which I did not see upset, as I have stated, were thrown over on their side across the main track, and were splintered and broken; that is, the boxes, the body of the car, roofs damaged, and cars generally racked, and besides the sidings of the cars broken. I do not say how many cars I saw that had been turned over. There were quite a number, but I cannot give the exact number. I did not keep any record of it. I should think there were 12 or 15, perhaps. They were scattered all along from Fifty-Fifth street north. They were lying across our tracks. These were not our cars. They were on the stockyards track, but they blocked our track so we did not get our passenger trains out on the night of the 6th at all,—trains which should have left at 5 o'clock. I say a part of those which were upset on the stockyards track, those were not our cars. Those were in charge of the stockyards company or some other road using their tracks. I should say 12 or 15 of our own cars on our own tracks were upset."

L. G. Haas testifies that he saw a crowd of persons engaged in overturning cars in the vicinity of Fifty-Fifth street on the 5th of July, and saw a number of cars that had been overturned.

E. M. Wineman testifies that on the 6th of July at Fifty-First street he saw a turbulent crowd of persons close up to the burning cars, and heard a number of persons in the crowd say they would not allow any cars to run.

W. J. Prindle testifies that disturbances on the plaintiff's road in Chicago began on the 28th of June and continued until the 9th of July; that at Forty-Seventh street July 6th employés were driven away from their work, cars overturned and burned, main tracks obstructed by piling timbers thereon and pushing cars from sidings; that a crowd of 300 people blocked the tracks, stoned him and other employés of the plaintiff, and threatened their lives; that this crowd was dispersed by soldiers. Thirty cars were burned in the Forty-Seventh street yard, switch targets destroyed, etc.

Richard Nelson testifies that on the 5th of July at Thirty-Ninth street he saw a car lying overturned, and a crowd of 500 to 1,000 people a little riotous; that he walked south along the tracks to Forty-Seventh street, where he saw a crowd of 200 people standing along the sides of the track, when suddenly 15 or 20 men rushed up to a car and turned it over on the main track, and then the crowd hurrahd; that next day about half past 9 o'clock he saw 15 or more men shove a car out from the siding onto the main track in the presence of several hundred people, who were yelling and holloing, laughing, and jeering; that shortly after, about half past 10, a fire broke out in the yard at Fifty-First street, and later when the firemen were there they were yelled at and hooted by a crowd of 40 or 50 persons; that a lieutenant of infantry with 15 men came up and charged bayonets on them. Twenty-two cars were burned at that fire.

The testimony of W. S. Morgan is to the effect that he saw a crowd tip over a car bodily at Fifty-First street July 5th, in the presence

of a crowd of 200 or 300, and then proposed to go to the roundhouse and blow up the _____ scabs.

The testimony of F. P. Smith is to the effect that on July 4th cars were upset and burned between Forty-Ninth and Fiftieth streets in the presence of a crowd of 300 or 400 people.

W. Kramer testifies that he saw a crowd of some 200 people at Forty-Seventh street July 5th, 20 or 30 of whom pushed some cars onto the track in front of his wrecking train and told him to pick up his tools and go home.

T. B. Hunt testifies that on July 6th he saw a large crowd at Fortieth street, where a milk train was stopped. The crowd hollered when raided by policemen, and shots were fired. Fire at Fifty-First street breaking out about that time.

Mr. Clapp saw a crowd surge back and forth along the track and upset cars near Fifty-First street; that the crowd said they were going to smash and upset the cars, and stop the road from running, and lay out the railroad men.

Thomas Griffin testifies that from the 1st to the 8th of July 300 cars were stored between Forty-Seventh and Fifty-Fifth streets; that crowds began gathering on the 29th of June, and the 3d of July cars were upset at Fortieth street; that July 4th a great crowd of people attacked the cars at Forty-Seventh street, and set fire to them, and tried to stop the firemen from putting the fire out. Pushed cars from the side tracks onto the main track; that the air was ringing with "Scabs!" that a great crowd at Fortieth street stoned a milk train, bruising it pretty bad and injuring the engineer; stoned and shot at the witness.

L. H. Pender testifies he saw persons gather along the tracks July 3d to 7th. Saw cars lying on the track, Forty-Seventh to Fifty-First street, and helped to pick them up with the wrecking train; was struck with a stone at Forty-Seventh street, and shot at near Forty-Fifth street, in the presence of about 500 people.

A. Cheffer testifies to seeing a crowd of from 100 to 300 persons at Fifty-First street in the afternoon of July 5th tipping over cars; that the same crowd raided a car of merchandise; that one of the crowd named "Shorty" called on others to go to the yards and kill some one.

Conductor E. Longhenry testifies as to how on the 5th of July he was assaulted and his train taken away from him at Forty-First street in the presence of a crowd of some 5,000 persons.

Engineer F. Stucker, of the same train, testifies as to how the mob stopped the train, got on his engine, and told him to go home, which he did.

Charles Fair, fireman on the same train, testifies as to how the crowd swarmed on and along the track, causing the train to stop, mounted the engine, and, seizing him, threw him bodily into the crowd, who caught him and carried him half a block away and told him to "git"; that the crowd overturned two cars on the track behind the train and put a rail through the spokes of the two driving wheels, so that the engine could not move; that from the 1st to the 5th of July they were frequently stoned.

Many other witnesses testified in a similar manner. There seemed to be no lack of evidence as to the fact of the property of the company being destroyed in consequence of the mob. It seems quite clear that the verdict of a jury upon such evidence as this must be conclusive that the destruction of the plaintiff's property was in consequence of the riot. The Chicago riots of July, 1894, are a matter of public history, and if the courts cannot take judicial notice of their existence it is only because the court is not presumed to know what every one else knows. The vital question in the case was, not whether there was a riot, but whether and to what extent the property of the Pennsylvania Company, which had many miles of track running through the south side of the city, was injured in consequence of it.

Exception was also taken to the introduction of the proclamation of the mayor calling for troops to suppress the riot, but such evidence was clearly admissible as a public act which had become a part of the history of those perilous and disturbing days, when danger to life and property throughout the city was imminent. The argument of counsel on this question that Hopkins had no authority to send the telegrams as mayor of the city, and that the sending of the state militia by the governor could not be lawfully in response thereto, but was only upon his own volition and responsibility, seems quite unfounded and irrelevant. What else could the mayor do, having the law to execute and the lives of millions under his charge, but call for military aid? It was a part of his official duty, and in the faithful discharge of it he should be upheld by all good citizens of the commonwealth.

It is also objected that the notice of claim served on the city was insufficient. It is only necessary to state what that notice was to show the triviality of such exception. This is the notice of claim for damages served upon the city, which is clearly sufficient, in connection with the attached schedule of property alleged to be destroyed, which is quite specific and lengthy:

"State of Illinois, County of Cook—ss.

"To the City of Chicago: You are hereby notified that, in consequence of a mob or riot, composed of twelve or more persons, the property of Pennsylvania Company, operating the Pittsburg, Ft. Wayne & Chicago Ry., was, within the city of Chicago, Cook county, Ill., while not in transit, destroyed or injured; that the dates and places of destruction or injury, and the damage to and description of said property, are stated in the schedule hereto attached, as accurately as can now be ascertained; that such destruction or injury was not occasioned, or in any way aided, sanctioned, or permitted, by the carelessness, neglect, or wrongful act of said company; that said company used all reasonable diligence to prevent such injury, damage, and destruction; and that claim against you for three-fourths of such injury, damages, and values is made, and payment thereof demanded, pursuant to the provisions of an act of the legislature of the state of Illinois, entitled 'An act to indemnify the owners of property for damages occasioned by mobs and riots,' approved June 15th, A. D. 1887.

Pennsylvania Company,

"Operating the Pittsburg, Ft. Wayne & Chicago Railway,

"By J. T. Brooks, 2nd Vice Prest."

One of the principal exceptions relied upon is that the title of the Pennsylvania Company to the property was not sufficient to war-

rant a recovery. The plaintiff's interest and title to the property was that of lessee and bailee,—to some as lessee of the Pittsburg, Ft. Wayne & Chicago Railway Company's track and equipment, and bailee of the certain cars marked with the initials of several other railroads, which were the general owners. As would naturally be expected, some of the cars destroyed belonged to other roads, and were in the possession and use of the plaintiff as bailee and common carrier for the time being. This gave the company a special interest in them, and it was responsible for the safe-keeping and return of the cars. The company was the owner in a sense, though not having the general title, and it is clear that the recovery cannot be limited to the property to which the company had the full title. Possession with a special interest as bailee is enough. It was not necessary that all persons having an interest in the property should be made plaintiffs. It could not have been contemplated that under the statute all persons having any interest in the property should be required to come to Chicago and bring separate actions, or join in one action for the recovery of damages. The statute did not change the general rule at common law that a common carrier may sue in his own name and recover for the value of the property which has been injured or destroyed by another while in his possession, and that bailees of property may sue in their own name and recover for wrongful injury to property in their possession. Schouler, *Bailm.* 531; *Ang. Carr.* § 348; *Story, Bailm.* § 93; *Hil. Torts*, p. 491, c. 18. Schouler lays down the rule thus:

"In conformity with the general doctrines of mutual benefit bailments, every common carrier is invested with a special property in the goods and chattels which a customer confides to him, so that he may maintain an action against any and all persons who disturb his possession thereof and injuriously interfere with the performance of his lawful duties. It is the general rule, applicable alike to real and personal property, that possession is both sufficient and necessary to maintain an action for a tort or wrong; more especially that 'bare possession gives a right against a wrongdoer for the invasion whereof an action of trespass will lie.'"

In *The Beaconsfield*, 158 U. S. 307, 15 Sup. Ct. 860, 39 L. Ed. 993, it was held that a carrier is so far the representative of the owner that he may sue in his own name, either at common law or in admiralty, for a trespass upon or injury to the property carried. And it was held in *Hardman v. Brett* (C. C.) 37 Fed. 803, 2 L. R. A. 173, that:

"Every bailee has a temporary qualified property in the thing of which possession is delivered to him by the bailor, which entitles him to maintain an action against any stranger who injures it; and the reason is because he is answerable over to the bailor and ought not to be responsible for the loss without being able to resort to the person who was the original cause of the injury."

See, also, *Railroad Co. v. McIntire*, 39 Ill. 298; *Railroad Co. v. Schultz*, 55 Ill. 421; *Benjamin v. Stremple*, 13 Ill. 466; *Hutton v. Arnett*, 51 Ill. 198.

Then it is objected that some of these cars destroyed were in transit and for which no recovery could be had under the statute. But the evidence shows that the cars were not in transit, but were stored in plaintiff's yards until wanted for actual use. The finding of the

jury upon this, as upon the other issues of fact, is final and cannot be questioned.

Various exceptions were made to the introduction of evidence and the refusal of the court to strike from the record, but we think no one of these exceptions maintainable, and if we do not notice them all in detail it is not because they have not been considered and passed upon. The trial lasted many days and many witnesses were sworn and examined. The case was well and carefully tried. An unusual number of exceptions were taken by defendant's counsel, but we find the record unusually free from error, and the plaintiff in error has little to complain of. "All hoods make not monks," and it is not every exception, or any number of exceptions poorly grounded, that can avail to reverse a judgment so well bottomed upon testimony and the verdict of a jury as is this.

The judgment of the court below is affirmed.

GEORGE FROST CO. et al. v. COHN et al.

(Circuit Court of Appeals, Second Circuit. December 15, 1902.)

No. 34.

1. PATENTS—PATENTABLE NOVELTY—SUBSTITUTION OF MATERIALS.

Whether the substitution of one known material for another in the construction of an article is patentable depends upon whether what was done involved the exercise of inventive faculty as distinguished from the ordinary skill of the calling, and when the substitution has accomplished a result which those skilled in the art had long and vainly sought to effect the evidence that it involved something beyond the skill of the calling is so persuasive that it generally resolves the inquiry in favor of patentable novelty.

2. SAME—HOSE SUPPORTER.

The Gorton patent, No. 552,470, for a hose supporter, claim 1, the essential feature of which is the substitution in the clasp of a well-known form of supporter of a button made of rubber or similar material having a fibrous, yielding, or elastic surface for the metal button of the prior art, was not anticipated, and discloses patentable novelty, in view of the marked superiority of the article as so constructed.

Appeal from the Circuit Court of the United States for the Southern District of New York.

For opinion below, see 112 Fed. 1009.

• J. Edgar Bull and Edmund Wetmore, for appellants.
A. D. Salinger and Frederick P. Fish, for appellees.

Before WALLACE and TOWNSEND, Circuit Judges.

WALLACE, Circuit Judge. The assignments of error challenge the patentable novelty of the hose supporter which is the subject of the patent to Gorton, No. 552,470, granted December 31, 1895.

The feature of novelty resides only in the material of which the button is composed, as supporters substantially similar to the one patented by Gorton were old, except that instead of having a button with a rubber shank or wholly of rubber the button and shank were of metal. The substitution of the rubber button was an improve-

ment of decided value. Supporters like that shown and described in the patent consist of two members,—one a plate with a button attached thereto, and the other a pear-shaped loop. Each member is attached to a strip of webbing, the loop member being usually mounted on a strip of elastic webbing. In using the device the fabric of the stocking is placed over the button, and with the button is then inserted through the large end of the pear-shaped slot, and the button is then drawn or forced into the contracted portion of the slot, so that the side walls of this contracted portion operate to hold the stocking firmly against the shank. With the metal button of the old device the fabric is gripped or clamped between two metal surfaces, the outer surface of the stud shank and the inner surface of the surrounding portion of the loop. If these metal surfaces are made smooth and round the fabric will slip between them, and even under a moderate strain will soon work its way free from the supporter. If, in order to overcome this objection, the metallic surfaces are roughened or sharpened to take a better hold of the fabric, they are likely to cut or wear the fabric away so that it will tear out or break away from the fastening, and may be badly damaged. Furthermore, the old fastener would not accommodate itself to different thicknesses of fabric, so that if the loop were fitted close to the shank of the stud to work well with thin fabrics it would not work properly with thick fabrics and was liable to injure them; and, on the other hand, if sufficient space were left to work better with thick fabrics, thinner fabrics would scarcely be held at all. Numerous patents had been obtained for modifications in the several devices composing the supporter intended to afford a clasp that would hold the fabric firmly without slipping and would not abrade under strain, and would be adapted for fabrics of different thicknesses. Beginning with the patent to Walker granted in 1878, and ending with the patents to Smith of 1893 and 1894, is found a long series of attempts. Some of these are for "garment supporters" in which the devices in combination are employed for the analogous use of holding up skirts or dresses as well as stockings. The patent of 1887 to Cattile is for a clasp in which the loop member is of flexible wire, and of a form which when the button is inserted will by its yielding and recession hold the fabric firmly. Smith, the latest inventor, endeavored in his patent of 1894 to remedy the defect by employing a button of which the shank was made of springing uprights. The difficulty was not satisfactorily remedied until the substitution of the rubber button of the patent accomplished the desired result; and notwithstanding hose supporters, having all the essential features of the patented clasp except the rubber button, were open to public use, the patented supporter at once met with great commercial success, and users and dealers promptly recognized its merits.

It is necessary that the button or stud be provided with a firm shank, which may be proportioned to the lower narrow end of the loop member, so that the fabric of the hose, interposed between the two, may be gripped or clamped between the shank of the stud and the portion of the loop surrounding it. The button of the patent is provided with such a shank, and the first claim, which is the

one that was adjudged valid by the court below, is for a supporter having with the other parts "the button composed of the central support and the surrounding rubber portion." The patentee, however, states in his specification that he prefers that the entire head of the button shall be of rubber. He also states in the specification that when he uses the term "rubber" in the claims he intends to include as an equivalent "any other material adapted to prevent the button from slipping, and having characteristics similar to rubber and adapted to the same use." By this he means to mention as an equivalent any material "having a fibrous, yielding, or elastic surface to which the garment tends to cling," as he elsewhere points out in the specification. In a later patent granted to him for a garment supporter, an article for an analogous use, he refers to the patent in suit, and states that it covers the use of other material than rubber, "including fibrous materials," and points out that "felt, fiber, cloth, and leather" would supply a surface to the button which would impart the desired characteristics, and form a surface to the button of a "yielding or elastic material."

It seems obvious that the claim in controversy is not to be limited to a hose supporter the button shank of which is made of rubber or surrounded with a rubber surface, and that it includes one in which the shank is made of or surrounded with any fibrous or yielding material, and that a button made of or covered with felt, fiber, cloth, or leather would, when combined with the other parts, infringe the claim.

As the scope of the claim must be as broad as any structure which would infringe it, the consideration of its patentable novelty is narrowed to the single question whether it was invention to substitute in the old hose supporter, in lieu of the metal button, a button made of rubber, leather, felt, or any other fibrous or yielding material to which the fabric of the stocking would tend to cling.

On first impression it would seem to have been an obvious thing to select some kind of material for the button that would resist the tendency of a smooth button to slip, although firmly gripped, and yield sufficiently, while resisting the slipping, to obviate the abrasion of the fabric. It was common knowledge that rubber is neither as hard nor as unyielding as metal, bone, or pearl. It was also common knowledge that it has the property of clinging, and its use on shoes, stairway steps, and for mats and floor coverings are familiar instances illustrating its adaptability to prevent slipping. It had also been used for buttons in order that its elasticity would permit the button to yield easily to sudden pressure, and yet not abrade the fabric of the button hole, as in the instance of the collar stud of the Allen patent. But in none of its prior uses had it been employed as the member of a device between which and another member a portion of the fabric was to be clamped. The instances of the prior use of such a material do not necessarily suggest its adaptability to do the work required of a button in a hose or garment supporter more efficiently than one of metal. That its selection was not an obvious thing is persuasively and cogently shown by the fact that during many years numerous inventors were trying to remedy the defects in the old device, and it did not occur to them how simply and satis-

factorily this could be done by making the button of rubber or some other elastic or yielding material. Its employment in the device of the patent was a new use, and imparted to the device a remarkable efficiency, as compared with that of the best type of former devices. Without the aid of such an experimental demonstration as was made upon the argument it would be difficult to realize the practical value of the improvement.

We have not overlooked the prior patent showing a device having a pair of jaws faced with springy or elastic material, which are pressed against the intervening fabric to hold it between them, nor the prior patent for a supporter in which an ordinary button of pearl or bone or some hard material is stitched to its place by thread. These patents are of insignificant value as anticipatory references, or as suggesting the adaptability of the material for the new occasion of its use.

It is not necessary to the patentable novelty of a device, which consists in employing a new material for an old one in constructing one of its parts, that the substitution should involve the discovery or utilization of an unknown or unexpected property of the material. This is one of the tests of patentable novelty, but it is not the only one. Whether the feature of novelty is the employment of a new material, or a change of adaptation in other respects, the inquiry always is whether what was done involved the exercise of inventive faculty as distinguished from the ordinary skill of the calling. When the substitution has accomplished a result which those skilled in the art had long and vainly sought to effect, the evidence that it involved something beyond the skill of the calling is so persuasive that it generally resolves the inquiry in favor of patentable novelty. Applying that rule to the present case, we conclude that the patent in suit, as regards the claim in controversy, is not invalid for want of patentable novelty.

A careful examination of the evidence has satisfied us that the invention of Gorton antedated the English patent to Knight. His long delay in making application for the patent creates a strong countervailing presumption, but is reasonably and adequately explained by the surrounding facts and circumstances, and, thus explained, ought not to prevail against the very convincing evidence which has been adduced by the complainants. The Knight patent is evidence that one out of a host of inventors working upon the same problem conceived the practicability of the rubber button. It is not evidence that there was no inventive thought in the conception, and as it was a publication later than the invention of Gorton it is of no value as an anticipatory reference.

Upon the evidence in the record the defense of an abandonment of his invention by Gorton does not merit serious consideration. The decree is affirmed, with costs.

MacWILLIAM v. CONNECTICUT WEB CO.

(Circuit Court, S. D. New York. November 25, 1902.)

1. EQUITY—EVIDENCE—OBJECTIONS TO ADMISSIBILITY OF DOCUMENTS.

There is no objection to a court's giving a certificate that an abandoned application for a patent, or a certified copy thereof, will be admitted in evidence in a suit in equity, if such certificate is required by the patent office as a prerequisite to the production or certification of the document; it being the duty of the court, under the rule of the supreme court, to receive it in evidence and make it a part of the record notwithstanding any objection to its relevancy, materiality, or pertinency.

In Equity. On motion for a certificate as to documents in the custody of the patent office.

Walter D. Edmonds, for the motion.

Herbert & Knight, opposed.

LACOMBE, Circuit Judge. It is not quite clear what sort of certificate this court is asked to give. No reference is made to any statute or to any rule or regulation of the patent office requiring a certificate of court as prerequisite to the production for inspection and copy of an abandoned application. For aught that appears, the commissioner of patents has full power in the premises. From the argument in the briefs of counsel for the respective parties, it would seem that the principal matter of dispute between them is as to whether the application is relevant and material to the issues in this suit. The supreme court, however, in *Blease v. Garlington*, 92 U. S. 1, 23 L. Ed. 521, has indicated that, in the course of taking proofs in equity, all such questions should be reserved for final hearing, and the testimony preserved for the appellate court should the decision at final hearing be adverse to its admission. This court is prepared to sign a certificate to the effect that, in conformity to the rulings of the United States supreme court, it would admit said abandoned application in evidence if it, or a certified copy, were offered, notwithstanding any objections to its relevancy, materiality, or pertinency.

In re GLASS.

(District Court, W. D. Tennessee. July 26, 1902.)

1. BANKRUPTCY—SPECIFICATIONS—OPPOSING DISCHARGE—AMENDMENT.

Specifications opposing a bankrupt's discharge, though entirely defective, may be amended at the discretion of the court.

2. SAME—SIGNATURE.

Specifications opposing a petition for a bankrupt's discharge (form No. 58) must be signed and sworn to by the opposing creditor, and, if there be more than one creditor, by each opposing creditor, and not alone by the attorney or counsel.

3. SAME—VERIFICATION.

The verification to specifications opposing a petition for a bankrupt's discharge must be in the form prescribed by the creditor's petition (form No. 3), to wit, that the creditor hereby makes solemn oath that the

¶ 1. See Bankruptcy, vol. 6, Cent. Dig. § 716.

statement contained in the foregoing specification of grounds of opposition to the bankrupt's discharge subscribed by him (or them) are true.

4. SAME—SIGNATURE BY CORPORATION.

Where the creditor opposing a bankrupt's discharge is a corporation, the signature to the specifications must be in the form prescribed by the supreme court under Bankr. Act 1867 for the petition of a corporation (form No. 3), to wit: "In witness whereof I have hereunto subscribed my name as president (or other officer or agent) of said corporation and affixed the seal of the same this — day of —,"—followed by the signature of the officer and seal of the corporation.

5. SAME—SIGNATURE AND VERIFICATION BY PARTNERSHIP.

Where the opposing creditor to a bankrupt's discharge is a partnership, the verification and signature of the firm to the specifications may be made by one of the partners authorized to sign the firm name.

6. SAME—VERIFICATION BY ATTORNEYS OR AGENTS.

Specifications in opposition to a bankrupt's discharge cannot be verified by the oaths of attorneys or solicitors or other agents, in the absence of a previous order of court allowing the same, in which event both the order and the oath should state the reasons therefor.

In Bankruptcy. On demurrer to specifications opposing bankrupt's discharge.

Frank P. Smith, for bankrupt.

Collier & Collier and Thomas M. Scruggs, for creditors.

HAMMOND, J. It is admitted by counsel that the specifications are not in proper form, and leave is asked to amend them. Objection is made that there is nothing by which to amend, the specifications being so entirely defective. There was an old doctrine that amendments could be made only where a good cause of action was defectively stated; but in modern practice, and especially under our liberal federal statutes of amendment, an entirely new cause of action may be stated in a pleading by way of amendment; and there are some very radical and startling rulings to that effect. Some decisions are against this, particularly where the bar of the statute of limitations is involved, or some like effect is the result of allowing the substitution of a new ground of action. Still the modern rule is that of great liberality in quite all cases, and it seems to me that, if the bankrupt has been guilty of any of the offenses for which his discharge may be opposed, the most liberal rule of amendment of the specifications should prevail, and that he should not be allowed to escape by the failure of the creditors to properly plead the grounds of opposition. The ordinary discretion of the court will protect the bankrupt against any injustice in the application of this liberality of amendment. His privilege of discharge from his debts is purely a matter of statutory grace, and not of any common right at all; and he should expect always to be denied a discharge unless he complies strictly with the conditions entitling him to that indulgence by refraining from any wrongdoing denounced by the statute as a bar to a discharge.

Here the specifications indicate that, if the facts be properly pleaded, there may be a bar. Not certainly so, and it may in the end turn out to be only a fraud upon creditors not made a ground for opposing the discharge; but it may be otherwise, and the averments

are not so entirely destitute of all merit as to invoke even the old rule of amendment relied on by the bankrupt's counsel. Rev. St. § 954; 1 Enc. Pl. & Prac. 462, 472; *Tilton v. Cofield*, 93 U. S. 163, 166, 23 L. Ed. 858; *Tiernan v. Woodruff*, 5 McLean, 135, Fed. Cas. No. 14,027; *Bank v. Sherman*, 101 U. S. 403, 405, 406, 25 L. Ed. 866; *Hunter v. U. S.*, 5 Pet. 173, 182, 8 L. Ed. 86; *Eberly v. Moore*, 24 How. 147, 158, 16 L. Ed. 612; *Richmond v. Irons*, 121 U. S. 27, 43, 47, 7 Sup. Ct. 788, 30 L. Ed. 864; *Graffam v. Burgess*, 117 U. S. 180, 195, 6 Sup. Ct. 686, 29 L. Ed. 839; *Shields v. Barrow*, 17 How. 130, 144, 145, 15 L. Ed. 158; *Smith v. Woolfolk*, 115 U. S. 143, 148, 5 Sup. Ct. 1177, 29 L. Ed. 357; *Hardin v. Boyd*, 113 U. S. 756, 764, 5 Sup. Ct. 771, 28 L. Ed. 1141. Under the act of 1867 such amendments of the specifications were allowed with liberality. *Bump, Bankr.* (9th Ed.) 281, 719; *In re Hill*, 2 Ben. 136, 1 N. B. R. 275, Fed. Cas. No. 6,482; *In re Rathbone*, 2 Ben. 138, 1 N. B. R. 294, Fed. Cas. No. 11,580 (where Judge Blatchford allowed them and enlarged the time on the distinct ground that the practice had not become settled); *In re Burk, Deady*, 425, 3 N. B. R. 296, Fed. Cas. No. 2,156; *In re Long*, 3 N. B. R. 66, Fed. Cas. No. 8,477; *In re Bellis*, 4 Ben. 53, 3 N. B. R. 496, Fed. Cas. No. 1,275. But not after issue joined, proofs closed, and case argued. *In re Smith* (D. C.) 16 Fed. 465, 467; *In re Graves* (D. C.) 24 Fed. 550. The discretion of the court is always available to prevent injustice to the bankrupt in the matter of these amendments. *Ubique supra*. The practice as to amendments under the existing bankruptcy statute of 1898 is just as liberal as under the former act and in other courts. They were allowed by this court in the first case coming before it. *In re Hirsch* (D. C.) 96 Fed. 468, 471, 2 Am. Bankr. R. 715, 718; *In re Holman* (D. C.) 92 Fed. 512, 1 Am. Bankr. R. 600, 605; *In re Hixon* (D. C.) 93 Fed. 440, 1 Am. Bankr. R. 610; *In re Morgan* (D. C.) 101 Fed. 982, 4 Am. Bankr. R. 402; *In re Frice* (D. C.) 96 Fed. 611, 2 Am. Bankr. R. 674; *In re Kaiser* (D. C.) 99 Fed. 689, 3 Am. Bankr. R. 767; *In re Mudd* (D. C.) 105 Fed. 348, 5 Am. Bankr. R. 242 (in which Judge Phillips denied an application to amend the specifications, and states the considerations that should induce such a denial). The doctrine of amendments in the admiralty courts is just as broad, and liberality in their allowance is commended by the highest authority. *The Zodiac* (D. C.) 5 Fed. 220, 222; 1 Enc. Pl. & Prac. 256. And even in criminal cases, where the statutes of amendment have the least effect, the practice is not destitute of all power of amendment. *Ex parte Bain*, 121 U. S. 1, 7 Sup. Ct. 781, 30 L. Ed. 849; 1 Enc. Pl. & Prac. 688. Thus we can see that to every court the statute of amendments (Rev. St. § 954) grants the fullest power and discretion. The bankruptcy statute being very liberal to the debtor in the matter of his discharge, confining the grounds of opposition to conduct on his part of a criminal nature or a quasi criminal carelessness and negligence, he should not be allowed to receive the acquittance of the statute because of any embarrassment or obstructions encountered by his creditors in presenting their opposition to his application for it. Only negligence of a culpable character on their part should debar them from the benefit of Rev. St. § 954, as to amendment of their specifications; and these,

it seems to me, are the considerations that should control the court in the exercise of its discretion in the premises.

Important questions of practice are made about the verifications of the specifications, which are conceded also to be defective; but it is complained that we have no rules of practice in this district regulating these details, and in this and other cases the necessity for verification of the specifications in opposition to discharge has been denied. One of the learned counsel for creditors insisted in the beginning that they do not require verification, and that they might be signed by counsel, and filed without it; but that, if they do require verification, he would not undertake, as an attorney, to verify them. He pointed to the fact, however, that forms Nos. 57 and 58 and general orders 31 and 32 do not prescribe any form of verification, while other forms do depend it wherever it is required. But this is only a fortuitous circumstance, I think, and quite indeterminate. These forms naturally are fashioned on those under the act of 1867, which required verification only in those matters where it was specifically provided by that act, or where the supreme court, exercising its statutory power to make the rules of practice and forms, chose to demand it. I have gone over those forms, and compared them with the forms under the existing act. Generally, each verification appended to the old forms was required in terms by the statute of 1867, though sometimes this was not so, as in form No. 40, for the removal of an assignee, which prescribes verification without any direction of the statute (Bump, Bankr. [9th Ed.] 924); while form No. 52 of the act of 1898 exacts none for the removal of a trustee (Loveland, Bankr. 770). The precept for verification does not appear to have been uniformly guided by the statute in either set of these forms. However this may be, the command of the statute of 1898 is imperative that "all pleadings setting up matters of fact shall be verified by oath." Section 18c. The omission of the supreme court, therefore, to prescribe a verification for a petition for discharge on form No. 57 of 1898, or for the specifications in opposition thereto on form No. 58, cannot override this plain command of the statute, if either of them be a "pleading," and "sets up matters of fact." Under the act of 1867, there being no such requirement, a verification might be, and often was, pretermitted in contracting the forms of 1867. And it is apparent that the draftsman of the new forms of 1898 factitiously followed the forms of 1867 in the omission of a verification without noticing this distinction between the two statutes. Thus he made forms No. 57 and No. 58 of 1898 conform, in respect of this absence of a verification, to forms No. 51 and No. 53 of 1867. Bump, Bankr. (9th Ed.) 930, 932. But in the one case the statute permitted the omission, and in the other it does not. Therefore it does not appear that in prescribing these forms the supreme court in 1898 has deliberately ruled that the specifications in opposition to a discharge are not "a pleading," and do not require a verification, under section 18c. That the specifications do "set up matters of fact" is beyond dispute, and that they have the form and substance of "a pleading" is equally clear; which being so, the omission of a verification from the new forms is a mere inexactness of compliance with the statute by the

draftsman, and does not bind us here, because the supreme court has overlooked the blunder.

It having been suggested that section 18c occurs in a section mostly, if not exclusively, devoted to procedure on an involuntary petition, it is insisted that its direction in respect of the verification of pleadings should be confined to involuntary cases. But this argument, and the rule of statutory construction on which it is based, are without force when applied to such an obviously patchwork structure as the whole statute shows itself to be. Besides, it is not in fact a section entirely concerning involuntary cases, and is under a subtitle of very much larger scope,—“Courts and Procedure Therein.” Again, neither the statute, the general orders, nor the forms make any distinction whatever between an application for discharge by a voluntary and one by an involuntary bankrupt. Nor do they suggest any distinction in the specifications in opposition thereto. Hence we are left confronted with the question whether they are “pleadings” in the sense of section 18c. This happens to be a voluntary case, but, if it were an involuntary case, precisely the same question would arise as to the verification being required by that section. Evidently it applies equally to both if it applies at all. There is a very narrow and technical sense in which the word “pleading” is confined both in law and equity practice to such formal written documents as the “declaration” or “bill,” the “demurrer,” the “plea” or “answer,” a “disclaimer,” and the like; but that is hardly the sense of this statute. Bouv. Dict. word “Pleadings.” It has seemingly rather the broader meaning there given of “stating in logical and legal form the facts which constitute the plaintiff’s cause of action or the defendant’s ground of defense; it is the formal mode of alleging that on the record which constitutes the support or the defense of the party in evidence.” Bouv. Dict. “Pleading in Civil Practice,” citing 3 Term R. 159; Doug. 278; Com. Dig. “Pleader”; Bac. Abr. “Pleas and Pleading”; Cent. Dict. word “Pleading”; 1 Enc. Pl. & Prac. 654, citing and quoting Snelling v. Darrell, 17 Ga. 141, where the restricted and more general meanings are each aptly disclosed in relation to statutes authorizing amendments.

It is not necessary to go into any nice discriminations of the practice in law or equity as to whether or when “a petition” can or does become “a pleading,” or when it is only a kind of extraneous statement for an outside purpose, and is de hors the technical record of the “pleadings.” The bankruptcy practice is, in respect of this, sui generis. It is all done by “petition.” It has no other formal statements except these and their concomitants, and in that relation the word “pleadings” of section 18c must mean “petitions,” and can refer to nothing else but those statements which come within the definition above quoted of a civil pleading, and the ordinary understanding of the meaning of that word. Bouv. Dict. “Petition”; 16 Enc. Pl. & Prac. 500, 511; 1 Enc. Pl. & Prac. 655, 656. The bankrupt’s “application for discharge” under section 14 is nothing more nor less than a “petition,” and is so called in form No. 57. On the analogies of equity practice as to “petitions,” those which are based wholly on the record, already made, and do not set up any extraneous

facts outside of any statute, would not require verification; but, setting up such facts, they would require it. 16 Enc. Pl. & Prac. 517; 22 Enc. Pl. & Prac. 1023, 1024. A petition for discharge avers, *inter alia*, that the petitioner "has duly surrendered all his property." That is a fact outside the record, known possibly only to himself as to its truth; and so it would seem that both by the statute and according to the analogies it should be verified by his oath, although this form does not call for it. So, also, the "specification of grounds of opposition to bankrupt's discharge" (form 58) is either an "answer" to the bankrupt's petition for discharge, and therefore a "pleading," in almost any sense, even the most technical, or else it is an independent petition, though not such in its form, asking the court to deny to the bankrupt his discharge because of the matters of fact extraneous to the record set up therein as the grounds of the opposition; and in either case, by all the analogies of any practice, and by the very terms of the statute, it surely requires verification. I cannot conceive of any kind of "pleading" which so certainly demands a verification as this "specification in writing." It is to all intents and purposes, under the statute, a criminal charge, or quasi criminal at least; and, while not possessing all the elements or consequences of criminal information or indictment, it is of so grave a nature that, if any "pleading" in any suit or practice reasonably demands verification by oath, that does most of all. Criminal informations are verified by the oath of the prosecuting officer or otherwise (10 Enc. Pl. & Prac. 451); and criminal indictments are verified by the oaths of the grand jurors. There is nothing in the bankruptcy record of so grave a nature as this, and it goes to the bifurcated root of the whole bankruptcy proceeding; for, on the one hand, the purpose is to distribute his voluntarily or involuntarily surrendered assets, and, on the other, to compensate him by a discharge. The shadow of the penitentiary also falls on his side of the general suit, when such charges are made; wherefore the reason for the exaction of all verifications is on the side of requiring it to such specifications, it seems to me. It was not so much so under the act of 1867, perhaps, though it must be admitted that this reasoning would have required it under that act also; and it was not demanded either by the statute or by the supreme court in its general orders or forms. And this may be the reason why the act of 1898 is so broad in its terms as expressed in section 18c.

While the petition for discharge is founded on the original petition in bankruptcy, voluntary or involuntary, and the record built upon that foundation, it is, after all, quite an independent proceeding, as are the specifications in answer to it. This is apparent from the statute, the general orders, the forms, and the entire procedure relating to the discharge and opposition to it. For this reason, also, it comes within the motive of the law for demanding the verification of pleadings under oath, in civil practice, which charge fraud and the like against the respondent, and likewise pleading under oath in answer to such a charge. That guaranty of good faith is the general principle at the bottom of such requirements, either under code practice or the general law in pleadings where the exaction is made. For example,

in explaining what pleas in equity are to be put in under oath and what not, it is said that generally those require verification where it will be necessary "to establish their truth by evidence upon oath at the hearing" (2 Daniell, Ch. Prac. [1st Ed.] 211); for the principle is that the court will not permit a defendant to delay or evade the relief sought by the plaintiff "unless he will first pledge his oath to the truth (or at least to his belief of the truth) of the facts upon which he relies, in all cases where the facts are those of which the court does not take judicial notice." Id. 112. And that is recommended by the learned author as the test by which the practitioner is to determine whether a given plea should be sworn to or not. Id. And in this case that is an all-sufficient test, and sheds abundant light upon the meaning of section 18c of the bankruptcy statute. Again: "Under the rules of chancery pleading a plea of matters in pais must be sworn to, and it is held that the waiver of an answer under oath in a bill does not waive the oath to the plea. A plea of matter of record need not be filed under oath, such a plea being proved by the production of the record." 16 Enc. Pl. & Prac. 594; Equity Rules 31, 32. 4 Desty, Fed. Proc. (9th Ed.) 517, gives form of verification of such a plea. It is a general rule that all petitions should be verified by an affidavit "that the facts therein contained are true, as far as known to petitioner, and that those facts which he states as knowing from others he believes to be true." Bouv. Dict. "Petition." And again, a petition should be signed by the party presenting it, and, when the facts upon which the application is based are not immediately before the court, a petition must be verified by oath; and that is also the practice in regard to petitions generally. 16 Enc. Pl. & Prac. 517; Swan v. Newman, 3 Head, 288. So this reason for the oath, and this test of discrimination whether it is due or not, permeates the civil practice everywhere, regulated definitely, sometimes, by statute and the Codes, but in federal practice mostly by the general law, unless by statute in particular instances, as in this bankruptcy statute. As to the verification of a bill, see 1 Daniell, Ch. Prac. (1st Ed.) 503; Id. (5th Ed.) 311, note 7; Id. 312, 313, 392-395. If there be several parties, all must join. Id. 396. For the verification by a corporation, see Id. 394, note 4, 396; for a form of the oath, see Id. 394, note 4; Id. 392, note 4; and for a corporation, Id. 2171, note 1; Id. 2172, note 4; Equity Rule 24; Fost. Fed. Prac. (3d Ed.) § 87, p. 240; Bates, Fed. Eq. Prac. § 123; 22 Enc. Pl. & Prac. 1015-1052. As to answers, all must be sworn to, unless the court specifically directs otherwise, or the oath be waived, where that privilege exists; though the reasons for that practice are somewhat different from those given for the verification of bills, pleas, and petitions, at least so far as pure equity practice is concerned. Unlike bills, the signature to answers is by the party himself, and not by attorney or solicitor; and so is the verification by oath, unless, again, by special direction, the court shall permit the signature and oath to the answer to be taken verbally by commission, and received without signature and oath, or that they be made by an agent duly and formally authorized. 2 Daniell, Ch. Prac. (1st Ed.) 268, 286; Fost. Fed. Prac. (3d Ed.) § 151; Bates, Fed. Eq. Prac. §§ 337,

342 (where the form of signature and verification both by natural persons and corporations are given); 22 Enc. Pl. & Prac. 1022, 1024, 1035, 1041-1043; Equity Rule 59. These are believed to be quite all the analogies to guide us in determining the practice in bankruptcy cases where the general orders and forms do not specifically direct us. General Order 37; Equity Rule 90.

In the very beginning there was a rule made by this court that attorneys should not be allowed to verify by oath the pleadings and proceedings in bankruptcy practice. The foregoing authorities show conclusively that such is the general rule in all courts, unless it has been changed by statute, and there is no act of congress permitting it. Where there is no statute, the practice in equity—and it is the same in bankruptcy—is that, when a party had to sign the pleading (as, for instance, an answer in chancery), or when a party had to verify the pleading, the signing or verification had to be done personally, and could not be done by attorney, both as to natural persons and as to corporations. In extraordinary circumstances—as that the party was beyond seas, or was mentally or physically incapacitated, or where the facts were peculiarly within the knowledge of the attorney, or the like—the court could make a special order that the signature and oath might be made by an agent or attorney; but always the previous order must be had, and the form of verification and signature must set out the special facts as a reason for the departure from ordinary practice; and this rule was very strict. The reason for it is plain,—that the adversary party shall have the responsible person bound by his own act, so that he should not be able to repudiate it, and put the other to the proof of an express or implied authority in the attorney, who might have neither, and, in the absence of a statutory authority, would have neither, except where the preliminary order of the court before mentioned had provided against that absence of authority. If the adversary party should challenge by a suit for malicious prosecution or otherwise that which had been done, it would be unjust, obviously, that he should be confronted with this interjection of outside and conveniently available defenses arising out of a denial of the attorney's authority. It is a very convenient and easy-going practice to allow attorneys to swear for their clients, saves time often, and expense, is one to which attorneys may readily resort, and is tempting, in fact, for these reasons; particularly if the swearing for one's client may be done upon "information and belief" as of course. But it is none the less a loose and unwise practice, condemned by the courts quite generally, even where it has been authorized by statute. In *Johnson v. Murray*, 12 Lea, 109, 116, Chancellor Cooper uses these apt words:

"The difficulties in this case, it may be added, have grown out of the loose practice, which ought never to be sanctioned, of permitting an answer to be filed without the signature of parties. The practice is equally objectionable of permitting petitions to be filed, signed, and sworn to by agents and solicitors, instead of by the parties themselves. The chancellor must have allowed the first petition, purporting to be by May and wife, to be withdrawn because it was not authenticated by, and therefore not binding on, them. But for this very reason neither petition ought to have been received."

It will be observed that all the existing forms in bankruptcy require the signature of the party himself. It may be, as in that of the debtor's petition,—form No. 1,—that the attorney signs it also, but not in any one of them,—certainly not in the petition for discharge or the specifications in opposition, forms No. 57 and No. 58,—does the attorney sign alone. Indeed only to the three petitions, respectively, of the bankrupt, of a bankrupt partnership, and of creditors for an adjudication in bankruptcy,—forms Nos. 1, 2, and 3,—is any provision made, or any note of any signature of attorneys; and not in one is there any verification by the attorney, except in proofs of claims, specially authorized to be so verified. There can be no implied authority, therefore, from the act itself, the orders, or the forms, for any signature or verification by an attorney. There must be some special authority by the court in the particular case for extraordinary reasons recognized as sufficient by general law, if it can be done at all. 2 Daniell, Ch. Prac. (1st Ed.) 268,—where it is said that, even where there be a power of attorney, and an authority of the court to sign by attorney, it is preferable to take the answer without signature, rather than to have the attorney sign the name of a defendant, so strict is this rule requiring the party to sign for himself. 1 Daniell, Ch. Prac. (5th Ed.) 395, note; 16 Enc. Pl. & Prac. 517; 22 Enc. Pl. & Prac. 1022, 1041, 1043. And where an attorney is allowed to take the oath it is on a special form. *Id.*; 4 Desty, Fed. Proc. (9th Ed.) 517, 819, in removal petitions; *Id.* 326, in admiralty pleading. In *Re Simonson* (D. C.) 92 Fed. 904, 1 Am. Bankr. R. 197, it was held that a petition in involuntary bankruptcy could not be verified by the attorney, and that section 1 (9) did not authorize it to be so verified. And in *Re Brumelkamp* (D. C.) 2 Am. Bankr. R. 318, 95 Fed. 814, it was held that the verification could not be taken before one's own attorney, where he was at the same time a notary. And in *Re Brown*, 50 C. C. A. 118, 112 Fed. 49, 7 Am. Bankr. R. 252, in the circuit court of appeals, Fifth circuit, it was definitely held that the specification in opposition to a discharge is a pleading, and requires verification, under section 18c of the statute. And as to the necessity for a verification of certain forms in bankruptcy, and especially of the petition for discharge and the specifications in opposition, see 22 Enc. Pl. & Prac. 379, 382.

The precise form required for the verification of any pleading is not, by the general law and practice, uniformly settled, is often doubtful, and difficult to frame, and presents some interesting conflict of opinion. Let us examine a little closely some of the varieties of form found in the verifications prescribed in these bankruptcy forms of 1898. A simple jurat, "Sworn to and subscribed before me," is often prescribed, as in that for a denial of bankruptcy,—form No. 6, for example. That prescribed for a debtor's petition (form No. 1) and a partnership petition (form No. 2) is a very common form of verification, but one that has been judicially criticised as defective, at least when it is appended to a paper that does not in its very text definitely point out that which is stated of the party's own knowledge and that which is stated only upon his information, while that of the creditors' petition (form 3) is a positive affirmation on oath

that the facts stated therein "are true"; that being the most absolute form known to the law, like that to a plea of non est factum (14 Enc. Pl. & Prac. 590; 16 Enc. Pl. & Prac. 546); or to a plea in equity (4 Desty, Fed. Proc. [9th Ed.] 517). And noticeably the verifications to the debtor's schedules are bare declarations that each is "a statement," etc., "in accordance with the acts of congress," etc., which acts of congress seemingly do not in terms require either oath to be "a true" statement,—section 7 (8); section 29 (2),—as did the act of 1867 (Rev. St. § 5015); and under the act of 1867 a corporation petition was signed by the president or other officer or agent, who affixed the seal of the corporation, and the oath was to be "changed to correspond with the form of the petition" (form No. 3, Bump, Bankr. [9th Ed.] 894). And it may be worth remarking here that a too close copying of the forms of 1867 may have resulted in making nugatory the oaths of the bankrupt to his schedules if they be challenged on an indictment for perjury. In *Re Brown*, 50 C. C. A. 118, 112 Fed. 49, 7 Am. Bankr. R. 252, it was held that the form of verification for specifications in opposition to a discharge should be "positive and certain, not vague and argumentative," and that the verification should be "by positive oath to the existence of the facts relied on as grounds for the same." This was said of verifications by the creditors in a form which states that "I am informed on reliable information, and have good reason to believe, and do believe, that the allegations and statements contained in the foregoing opposition to discharge are true"; and also by an attorney to the same effect, only he set out in his oath the sources of his information; both being held insufficient; and this decision is by the court of appeals of the Fifth circuit.

The familiar form for the verification of a bill in equity when that is required in practice is by an appended affidavit the wording of which is suited to the fact that the text of the bill itself states distinctly that averment which is made of the pleader's own knowledge and that which is made upon his information. But not one of these bankruptcy forms does this, as will be seen by inspecting them. Yet the debtor's voluntary petition has prescribed for its verification the common form of an affidavit to a bill,—a form of oath which is discredited by the authorities when the pleading does not in its text make discrimination between statements of one's own knowledge and of one's information from others. 22 Enc. Pl. & Prac. 1021, 1022, citing *Stirlen v. Neustadt*, 50 Ill. App. 378, where it is said that under such a verification it can only be known "by probing the mind of the pleader," which statement is given on self-knowledge and which on information only. See, also, *Fost. Fed. Prac.* (3d Ed.) § 87, note 10. On the other hand, the creditor's involuntary petition has its verification in the absolute form of a plea in equity, namely, "that the statements subscribed by them are true." An analysis of the petition filed by creditors and a comparison of it with the debtor's own petition and the partnership petition show that the two latter state facts that naturally are within the petitioner's own knowledge; while the other states some facts that naturally are within self-knowledge, such as those relating to the nature of the creditors' claims, and oth-

ers that naturally, or generally, rather, would be derived from information, such as those relating to the acts of bankruptcy. And yet according to the form they must swear as positively to these last as to those stated of self-knowledge. As to the forms of verification generally, see 22 Enc. Pl. & Prac. 1022, 1041, 1043; 16 Enc. Pl. & Prac. 594; 4 Desty, Fed. Proc. (9th Ed.) 517, 819; Fost. Fed. Prac. (3d Ed.) §§ 87, 151; Bates, Fed. Eq. Prac. §§ 123, 337, 342; 2 Daniell, Ch. Prac. (1st Ed.) 270, 286; Id. (5th Ed.) 394, note; Id. 743, 2171, 2172. Certainly the framework language of specifications in opposition to a discharge would not naturally take the form of a bill in equity, but rather that of a criminal information or indictment; wherefore the verification of a bill would hardly adapt itself to such a pleading.

Now, then, when a nicely discriminating and sensitive conscience comes to scrutinize these oaths which it is to take, it is very natural that one with such a conscience should hesitate to swear that charges made on the information of others "are true." Naturally, one would prefer to swear that one "believes them to be true." But it may be that the pleading to which he is swearing does not, in its text, discriminate between actual knowledge and information. If it be specifications in opposition to a discharge, it would be very difficult to so frame it as to meet the wants of the tender conscience, and put it in that shape. Practically it cannot be done, if technically it would be good. Neither can the affidavit of verification itself be any more practically so framed. By order of the supreme court a petitioning creditor must swear that facts that he states in his petition (form 3) on the information of others "are true," and why should he not make the same oath when he comes to specify his grounds opposing the discharge, albeit the knowledge come from others? In the very nature of the case it is to be implied that the oath is upon information, or, at least, it may be the one way or the other; and he is entitled to salve his conscience with the palliating implication. He must so salve it in the creditors' petition; and at any bar, in a trial for perjury, say, his oath would be so understood, especially where it was compulsory; and let us hope that it would be so understood in any court of conscience and at the bar of the Almighty, when He shall come to judge all of us in mercy and in truth. Psalms, lxxxix. 14.

I sincerely sympathize with the sensitiveness of litigants on this subject, as the law has always done in framing these forms of verification by oath; and would be inclined to be satisfied that the statute would be met by that form of oath which the supreme court appends to the debtor's petition (form No. 1) and to the partnership petition (form No. 2), notwithstanding the sensible objection to it set forth by the courts in Illinois and elsewhere. The statute might not be as completely satisfied by those verifications, but sufficiently, nevertheless, as it is by the form appended to the creditors' petition (form No. 3), also by that court. But for the sake of precedent and uniformity of practice, if nothing else, until the supreme court itself shall prescribe the form of verification for the specifications in opposition to a discharge (form 58), I feel constrained to adopt in this

district the form sanctioned by our Brother Meek in a Texas district, and approved by the circuit court of appeals for that circuit, and we will follow the form of verification to a creditors' petition (form No. 3), which has been sanctioned by the supreme court for a pleading not less obnoxious to the sentiment of a scrupulous regard for one's oath. In re Brown, supra.

The result here is:

1. The specifications opposing a petition for discharge (form No. 58) must be signed by the opposing creditor as indicated in the form itself, and not alone by the attorney or counsel, and must be sworn to by him.

2. If there be more than one creditor joined in the specifications, all must so sign it, and all must swear to it.

3. The verification must be in the form prescribed by the creditor's petition (form No. 3), to wit:

"Do hereby make solemn oath that the statements contained in the foregoing specification of grounds of opposition to the bankrupt's discharge subscribed by me (or them) are true."

4. If the opposing creditor be a corporation, the signature to the specifications must be in form prescribed by the supreme court under the bankruptcy statute of 1867 for the petition of a corporation (form No. 3, Bump, Bankr. [9th Ed.] 894), to wit:

"In witness whereof, I have hereunto subscribed my name as president (or other officer or agent) of said corporation, and affixed the seal of the same, this _____ day of _____ A. D.

"[Seal of the Corporation.]

(Signature of the Officer.)"

5. The oath of verification prescribed for other creditors as above set out must be made by the officer of the corporation, mutatis mutandis.

6. When the opposing creditor is a partnership, the signature of the firm name by one of the partners authorized to sign the firm name will be sufficient; as also the verification by him alone or another partner, if the facts be known to him and not the partner signing the pleading, the form of the oath stating the fact as it may be.

7. The attorneys or solicitors or other agents will not be allowed to take the oath to the verification, and the already existing rule of this prohibition as to all verifications in bankruptcy proceedings will be enforced, unless there be a previous order of the court allowing the oath to be taken by an attorney for reasons appearing in the order and on the face of the oath itself.

Ordered accordingly.

In re BABER.

(District Court, E. D. Tennessee, W. D. August 28, 1902.)

No. 104.

1. BANKRUPTCY—PROCEDURE BEFORE REFEREES.

On an application of a trustee in bankruptcy to the court for advice as to whether he should file a petition to have the claim of a creditor expunged for fraud, the referee has no authority to hear and determine the subject-matter of such petition on the merits.

2. SAME—TRUSTEES—APPLICATION FOR ADVICE.

An application by a trustee for the direction of the court as to whether he shall sign and file a proposed petition against a creditor, prepared by counsel, which alleges that such creditor fraudulently proved his claim as unsecured, and received dividends thereon, while at the same time it was prosecuting a suit in the state courts to enforce collateral security held for the debt, should be denied, and the trustee left to act in the matter on his own responsibility, aided by the advice of counsel, and, if he desires, by that of the creditors.

3. SAME—POWERS AND DUTIES OF TRUSTEES.

While a trustee in bankruptcy acts in a certain sense under the direction of the court, he is vested by the law with the title to the bankrupt's estate, and charged with duties with respect to the same which he is required to perform with intelligence and on his own responsibility. He may employ counsel, using such judgment as an ordinary man would in the transaction of his own business, and may apply to the creditors for authoritative advice and instructions upon questions of expediency, or for assistance with money to conduct litigation if without funds; but he is not entitled to devolve upon the court the responsibility of directing his actions where his legal duty is plain.

In Bankruptcy. On petition to review action of referee.

This is a petition to review the action of the referee on the application of the trustee for instructions by the court. The adjudication of the bankrupt was made October 30, 1900. At the first meeting of the creditors, December 2, 1900, the Bank of Huntingdon proved its claim as one without security for the sum of \$2,172.76, and a brother of the cashier of the bank was elected trustee by the creditors. Subsequently, January 29, 1901, and June 12, 1901, the bank received as dividends on its claim an aggregate sum of \$608.37. As a matter of fact, at the time the bank proved its claim without security, it held two notes of one Hardin, which had been secured by a purchase-money lien for land sold to Hardin by one McCracken. These notes were for \$175 each, and had been assigned to the bank by Baber, the bankrupt, in March, 1900,—the particular date not being shown by the record,—as collateral security for the indebtedness then held by the bank against Baber, which was subsequently proved in bankruptcy as above stated. These collateral notes had never been paid, but subsequently to their assignment to the bank one Swift filed a bill in the state chancery court against Hardin, the maker of the notes, and others, the purport of which is not shown by the record; nor is the date of the filing of that bill shown by the record, but it may be inferred that it was subsequent to the adjudication of Baber in bankruptcy. However this fact may be, both Baber and the bank were made parties to that bill, and the bank filed a cross-bill to enforce the lien of its collateral security by a sale of the land. Neither is the precise date of the filing of this cross-bill shown, but it is to be inferred that it was subsequent to the adjudication in bankruptcy, and subsequent to the proof of debt by the bank in the bankruptcy proceedings. Because in the proceeding now under consideration it is stated "that in the pleadings in said cause in which the said decree was rendered no mention is made of the said bankrupt proceedings," the trustee in bankruptcy was not made a party to this bill, nor was he brought in after his appointment by the plaintiff in the bill, nor by the bank in its cross-bill. He and the bankruptcy proceedings were wholly ignored throughout the progress of the case in the chancery court and the supreme court of the state. The case was conducted as if the bankruptcy proceeding had had no effect upon the right or title of the bank or Baber to the collateral notes. On the 14th of February, 1902, a final decree was made in the chancery court, which declared a lien in favor of the bank for \$373.79, the aggregate amount of the notes, and enforced the same by a decree of sale if the money should not be paid in 30 days from the date of the decree. The decree states that no decree is rendered against

¶ 2. See Bankruptcy, vol. 6, Cent. Dig. § 346.

Baber, "because he is a nonresident," and the bill is dismissed as to him. This decree, on appeal, was subsequently affirmed by the supreme court. On the 14th day of August, 1902,—one year eight and a half months after his appointment,—the trustee appeared by Joseph R. Hawkins, Esq., an attorney, at a meeting of the creditors before the referee, and moved "to be allowed to file the following petition on behalf of the trustee." But, "stating that the trustee desired to be instructed and directed by the court whether or not he should file the same," it also appears that the trustee stated through said attorney that "the trustee would only sign and qualify to the petition, and file the same, when directed to do so by the court." It does not appear whether the said attorney, Hawkins, was employed by the trustee to take these proceedings against the bank, or whether he represented some of the creditors, and was endeavoring to reach the end desired through the acquiescence of the trustee. Neither does it appear how the bank came to enter its appearance to this application of the trustee to be allowed to file the petition. It does not appear that any process was issued against the bank to answer the petition, nor that any notice was issued to it to appear and resist or show cause against the application by the trustee for instructions from the court. The bank did not file any answer to the petition or otherwise make any issue upon it; nor did it make any response to the application for instructions and for leave to file the petition in the nature of a response to a rule to show cause. Nevertheless, the report of the referee states as follows: "Whereupon Geo. T. McCall, attorney for the Bank of Huntingdon, tendered to the trustee the recovery had on the alleged preferences, which tender was reduced to writing, and which is in words and figures following, to wit: 'This paper writing is a formal tender to the trustee of the recovery "in the case of Swift v. Hardin in favor of the bank upon the collateral notes,' less, however, 'all expenses of litigation, including attorney's fees.' The petition of the trustee which it was proposed to file under the instructions of the court in that behalf sets out the facts as above related concerning the proof of the debt of the bank without security, and the institution and prosecution to enforce the lien of the collateral notes and the payment of the dividends to the bank without any disclosure by the bank to the trustee, the creditors, or the bankruptcy court of the fact that it held the collateral notes, or without any disclosure to the state courts of the fact of bankruptcy. The petition insists "that this was in such bad faith as to the rights of other creditors of the said Baber as should repel the said bank from your honor's court, and that said bank should be required to refund to your petitioner the entire amount so received by it for the benefit of other creditors of said Baber, and that said bank should be required to turn over to the petitioner all rights to the said two notes." The petition does not, in terms, pray, as it should have done, that the claim of the bank should be expunged and disallowed entirely; neither does it set up any facts to show that the assignment of the collateral notes by Baber to the bank was a fraudulent preference under the bankruptcy statute, such as that Baber was insolvent, either with or without the knowledge of the bank, at the time the collaterals were assigned to it. It does appear, however, from the report of the referee and the proof that was taken, that the assignment of the collateral notes to the bank by Baber was some time in March, 1900. This was at least seven months before the petition in bankruptcy was filed, and, if that be the correct date, it is difficult to see how the offer of the bank to surrender the collateral notes and the recovery thereon could be based on any notion of the surrender of a fraudulent preference under section 57g of the bankruptcy statute; nor why it should be assumed by the attorney for the bank and accepted by the referee as an obligation or duty of the bank to make such a tender or surrender. But the referee in his report bases his judgment of acceptance of the surrender by the trustee as for the best interest of the estate upon the ground that it is the full value of the securities to be estimated under section 57h of the statute. Yet under that section, as no surrender of these securities is required or contemplated, it seems that it must be inferred as one of the facts that the tender by the bank was by way of a voluntary surrender, and in the nature of a compromise offered to the trustee, and a compromise which the referee by his decision forces the trustee

tee to accept. Although there is no prayer in the petition offered by the trustee to be filed that the proof of debt made by the bank shall be expunged, there is a claim tantamount to such a prayer by the insistence above quoted that the bank should be required to refund to the trustee the entire amount of dividends received by it; and, besides, there is a general prayer as follows: "Wherefore your petitioner prays that he be allowed to file this petition, and that a subpoena be issued and served upon the Bank of Huntingdon, as provided in the act of congress relating to bankrupt proceedings, and that your honor may make such rules and orders as may to your honor seem proper and right, and that such judgment or orders may be entered as will meet the ends of justice and the law in bankruptcy proceedings." The special relief that the petition demands is that the dividends be returned to the trustee, and "that said bank be required to turn over to the petitioner all rights to the said two notes," but the general prayer for relief is as above quoted.

The deposition of the cashier of the bank was taken by the parties, and offered in evidence in support of the application for instructions and for leave to file the petition and the answer and the cross-bill of the bank in the case of *Swift v. Hardin et al.*, and the final decree of the chancellor in that case was also offered in evidence. This was a very unusual proceeding on such an application, and was wholly unauthorized in any view we can take of the case. But it is not necessary to further notice this proof in this statement of the facts, as the essential features appear in the proposed petition, and have already been related here.

The conclusions of law and fact as found by the referee are as follows:

"It is conceded that at the time the bank filed its proofs of debt that it held the securities complained of in the petition, and held the securities as a collateral, as set out,—as a collateral to secure the indebtedness filed. Section 57 of the bankrupt act reads as follows: 'Proof and Allowance of Claims. A proof of claim shall consist of a statement under oath in writing signed by a creditor setting forth the claim, the consideration thereof, and whether any, and if so, what securities are held therefor, what payments have been made thereon and the sum claimed is justly owing from the bankrupt to the creditor.' Section 57, par. 'g,' of the act, reads as follows: 'The claims of creditors who received preferences shall not be allowed, unless such creditors shall surrender their preferences.' Section 57h of the act reads as follows: 'The value of securities held by secured creditors shall be determined by converting the same into money according to the terms of the agreement pursuant to which the securities were delivered to such creditor or by such creditor and trustee and a dividend shall only be declared on the unpaid balance.' Form 33 (32 C. O. A. lxvii, 89 Fed. xliii) of the forms in bankruptcy, under which this claim was by the bank proven, it being of the form prescribed by the supreme court of the United States, as required by the act, requires the creditor to disclose any payments, set-offs, counterclaims, and what securities he holds, if any. The clear intention of these various sections are to provide an equitable distribution of the bankrupt's estate amongst his creditors, to prevent preferences, and to this end it is provided by the act that all liens, mortgages, deeds of trust that have been placed on the property within four months next preceding the adjudication of the bankrupt shall become void; and it is also clear that securities held for the protection of the debt filed shall be disclosed for the purpose of ascertaining whether it has been given as a preference, or, if a just and legal security, and not be made void by the act of bankruptcy, then that it may be taken into account, and reduce the debt filed to the extent of its value, and an easy mode provided for the ascertainment of its value, and, when so ascertained by the bankruptcy court, that it may be applied as a credit on the debt, and thus reduce the debt, and the pro rata be declared only on the remainder of the debt after the value of the securities are ascertained. The case at bar is not out of the ordinary, except in this: that the claim was filed on December 22, 1900, and allowed more than two years and eight months since, and the trustee at this late date makes the discovery of the securities so holden by the bank; and the further fact that the bank failed or omitted to disclose the securities so holden by the bank; and the further

fact that the bank failed or omitted to disclose the securities at the time of the filing of the claim. Two pro ratas have been declared and paid on the debt, and several meetings of the bankrupt's creditors have been held, since the filing of the claim. The proof also shows that the matter of said securities so holden by the bank was in litigation at Huntingdon, the home of the attorneys and the trustee all of the time of the pendency of this bankruptcy. The history of the bankruptcy proceedings before the referee being as follows: The matter was, on the 30th day of October, 1900, referred to the referee, the first meeting of creditors held on the 22d day of December, 1900, and on that date the claim of the bankrupt was proven and allowed; and the petition to review the claim of the bank is at this late day filed, offering no excuse for the failure to discover the error of the bank in failing to disclose these securities earlier. The total amount of the debts proven by the bank amounts to \$2,172.76; total amount of dividends paid bank \$608.37, the same having been paid in two pro ratas,—the first, 10 per cent., paid on the 29th of January, 1901, and the second, 18 per cent., paid 12th of June, 1901; total amount of securities held by the bank complained of \$350, in two notes executed by A. S. Hardin to S. A. Hardin. Now, if these two notes had been surrendered at the time proof of debt was filed, and the bankrupt court had reduced them to cash, and had realized this face value, they would have obtained \$350 for all creditors, if the same was void (holding which is not contended, nor charged in the petition); and we must infer that it was a valid security in the hands of the bank, and that when this court reduced it to cash it would had to have been applied on the bank's indebtedness to that extent, which would have left the sum of \$1,822.76 as the remainder due the bank, upon which dividends would have been declared, which would have left the following results: Twenty-eight per cent. of \$1,822.76 is \$510.23. They were paid \$608.37, or \$98.14 too much, which amount of \$98.14 would have been left in the general fund for distribution if the results above had been reached by tendering of the securities in the outset. But the bank now comes in, and tenders the entire amount of the securities,—does not ask that it be credited on their debt, and that they receive dividends on the remainder, but tenders it as a fund to be distributed among all creditors. And the question to be decided for the trustee is, which of the two propositions is the best for the general estate,—to have the \$98.14 returned into court, or accept the \$350 in securities for general distribution? The matter of the securities having been fought through the courts, a lien fixed and adjudicated by the supreme court of Tennessee, and the property ordered sold to satisfy the lien, it is clear to my mind that the interest of the estate will be best subserved by accepting the tender. No fraudulent concealment of the right of action is alleged in his petition for review, etc. The only charge in the petition that would indicate a fraudulent intent to conceal the securities held by the bank is as follows: 'Said bank, with full knowledge of the fact that said two notes were holden by it as collateral securities, and the date of said bankruptcy, and, as above set out, without disclosing, but concealing, in said bankrupt proceedings the fact that it held said notes secured, petitioner insists that this was in such bad faith to the rights of other creditors of said Baber as should repel said bank from your honor's court.' The charge or allegation is tantamount to alleging that the bank knew it held the securities at the time the proofs of debt were filed, and concealed the fact; that this was bad faith, and for which they should be repelled from court. A fraudulent concealment of the securities held would repel the bank from this court, but this is not alleged in terms nor in language that can be construed into such an allegation. Fraud, like crime, must be specifically alleged. The intentionally concealing, for the fraudulent purpose of injuring or damaging another, some material fact, must be alleged, and, inasmuch as no such allegation is made, and every intendment in pleadings is taken against the pleader, it is fair to this court to presume from the face of the petition that no actual fraud was intended, and no such fraud as would or should repel the bank from this court. The allegation in the petition, 'with full knowledge of the fact without disclosing, but concealing,' is not sufficiently charged to justify the court to infer the animus,—the dolus. This being true, and the

further fact that the bank now comes in and proposes to turn over the securities held by it that are complained of, and thus do what it should have done in the beginning, and restoring to the trustee in this bankruptcy at this date all that it could have turned over to the court at the date of the filing of the proofs of debt, it thus no doubt proposes to do all that this court could or would, through its orders, force it to do. I am therefore of the opinion that the filing of the petition and further litigation, expenses, and charges against the estate in bankruptcy will be useless expenditure of money, time, and energy, and I therefore decline to allow the petition to be filed."

Joe. R. Hawkins, for trustee.

Geo. T. McCall, for Bank of Huntingdon.

HAMMOND, J. (after stating the facts). Counsel for the Bank of Huntingdon and the trustee have both applied by letter to be heard in argument upon the questions raised by this petition for a review of the action of the referee, but the matter can easily be disposed of without any argument. Technically, the bank has no right to be heard at this stage of the proceedings, and the argument would be only a matter of courtesy to the bank and its counsel. The application of the trustee is for advice and a direction of the court as to the propriety of his bringing suit against the bank by petition in this court. In the nature of the thing, the bank is not a proper party to such an application by the trustee. It might become a party, under some circumstances, by a proper order of the court; but this proceeding has not progressed to that extent. Therefore, as the bank cannot be bound by any action taken by the court upon this application of the trustee, strictly speaking it has no right to be heard in argument. The court will be very glad to hear the learned counsel for the bank whenever the questions that may be made against it are to be adjudicated.

Notwithstanding that this is only an application by the trustee for instructions, the referee has heard the parties, and taken the proof, and decided the case between the bank and the trustee as if it were presented for final decision. The court cannot approve this action of the referee; nor, if the matters were properly presented for decision, is the court quite prepared to say that it would approve the judgment of the referee; but the truth is the questions between the trustee and the bank are not ripe for decision. The application of the trustee for advice and instructions of the court ought to have been denied, and, if a proper application were made by any creditor for the purpose, it is not impossible that the trustee ought to be removed, and another substituted, who is not so squeamish about the proper discharge of his duties, and not so timid about taking responsibility. That which the trustee should have done was to engage competent counsel to advise him, submitted the facts of his controversy with the bank to such counsel, and followed his advice in the matter of bringing whatever suit was necessary against the bank, or taking such other steps as he might be advised. If not in funds to pay counsel, he should have notified creditors of that fact, and, if necessary, ask the referee or court to call a meeting of the creditors to advise him of their wishes in the premises, and to act accordingly. The court has a strong suspicion, from the facts shown in this record,

that the trustee is acting disingenuously in making this application, and for the purpose of favoring the bank. It appears that the trustee is a brother of the cashier of the bank, who acted for the bank in the transaction involved. It is fairly to be inferred that this brother of the cashier received his appointment as trustee through the preponderating vote of the bank at the first meeting of the creditors. It would seem singular that he would remain in ignorance from the date of his appointment, in December, 1900, to the 14th day of August, 1902, of the fact charged in the petition that the bank had fraudulently concealed its possession of collateral securities for its debt, and that it had during that time carried through the chancery and supreme court of the state a proceeding to enforce the lien of its collateral securities upon the lands of Hardin. Why did the trustee not proceed against the bank more promptly? The record does not answer this question, except with a suspicion as above indicated. It does not appear whether the learned counsel who prepared the petition of the trustee now offered to be filed was engaged by the trustee to represent him, or is representing creditors seeking to call the bank to account for its alleged fraud in withholding the knowledge of the fact that it held the collaterals, of proving its debt without security, collecting full dividends without disclosing the truth, and at the same time trying to enforce the lien of the collaterals in the state court. But on the facts as shown in the petition it is preposterous that any trustee understanding his duty should not have proceeded against the bank as soon as the facts came to his knowledge. That he should refuse to sign and file this petition on the advice of this counselor, by whomsoever he was employed, until he should be instructed by the court to do so, seems to be, on the facts as shown by this record, disingenuous, to say the least of it. Undoubtedly, by the very terms of the bankruptcy statute, the trustee acts at all times technically under the direction of the court, and no doubt he has on proper occasions and under proper circumstances, the right to apply to the court for its instructions in the premises. Section 47(2). But this does not mean that he can shovel the administration of his trusteeship into the court, unload his responsibility upon the referee, or judge of the court, and evade or shirk his plain duties by asking the advice and directions of the court. Properly, he should be a man of affairs, ready to act upon his own responsibility and intelligence, as business men do in their own affairs; if necessary, resort to the advice of counsel; and, still more, if the further necessity exist, resort to the tribunal of the body of the creditors assembled in general or special meeting called for the purpose under the presidency of the referee or judge, as provided in the scheme of the act. It is for such purposes that meetings of the creditors are provided for, and, until resort has been had to these appliances to guide his judgment, and complications of a serious nature have arisen, it is disserviceable that a trustee should be applying to the court for its instructions and advice.

There is no provision in our bankruptcy statute, as in the English statute, specially authorizing trustees in bankruptcy to apply to the court in manner prescribed for direction in relation to any particular

matter arising under the bankruptcy. *William*, Bankr. 294, 467. But there is no doubt that such authority may be implied from the general scheme of the act of congress, and especially from section 47(2), where the duty is prescribed of collecting and reducing to money the property of the estate "under the direction of the court"; but, as before remarked, this does not mean that the trustee may devolve the administration of the estate upon the court by such applications. There was a similar provision as to all general trustees under Lord St. Leonard's Act (22 & 23 Vict. c. 35, § 30), but it was held under that act that the court would not adjudicate in that way upon doubtful points of fact or law, the decision of which would materially affect the rights of parties interested. When the trustee asked, under that act, for instructions, the court would require notice to be given to the parties interested, and, if it required formal suit between the trustee and the adverse parties, the court would remit the trustee to such action as he ought to bring under the advice of counsel. *Lewin*, Trusts, 352, § 28; *Id.* 618, § 18; *Id.* 620, § 23. We have the same rule in this country, which is thus expressed: "The trustee will not be permitted to seek the advice of the court upon a mere question of law about which he should have consulted an attorney, or, if necessary, tested the question by an action at law." 27 *Am. & Eng. Enc. Law* (1st Ed.) 153, citing *Greene v. Mumford*, 4 R. I. 313.

It is not necessary to particularly inquire in this place as to the limitation upon that authority in the practice of giving advice or instructions by courts of equity to trustees by contract or private appointment, such as donees of powers, executors, and the like, quasi official trustees,—as administrators, guardians, and the like; for a trustee in bankruptcy is not that kind of a trustee. Neither is he quite the same as a receiver of a court, although there is more analogy here than in the cases of trustees by contract applying to a court of equity for instructions. The rule of practice as to such applications by a receiver is laid down in *Fost. Fed. Prac.* (3d Ed.) p. 549, § 248, where the author quotes from a decision in the case of *Missouri Pac. Ry. Co. v. Texas & P. Ry. Co.* (C. C.) 31 Fed. 862, as follows:

"If there are parties in interest, and they have their day in court, the advice may be decisive. But if the matter is *ex parte*, the value of the advice depends largely upon the information and the ability of the judge, and is probably binding only on the receivers, for the judge may change his mind on hearing full argument."

See, also, *Fost. Fed. Prac.* (3d Ed.) 542, 557, and *Bates*, *Eq. Prac.* § 614.

It will be seen from these and other authorities that the privilege of trustees to apply for advice cannot be abused by running to the court to settle every question that may appear to an irresolute trustee to be desirable to have settled without responsibility of action on his part. Nor can this practice be resorted to for the purpose of carrying on litigation between himself and adverse parties in such an informal and irregular way as has been done in this case. Trustees in bankruptcy are *sui generis*. As was said by Judge Purnell in the

case of *McLean v. Mayo* (D. C.) 113 Fed. 106, 7 Am. Bankr. R. 115:

"While the bankruptcy act creates the office of trustee in bankruptcy, such trustee is a quasi officer of the court in a qualified sense. He is in reality elected by, and represents the creditors of, the bankrupt, under the provisions of the bankruptcy act. The bankruptcy court will protect the trustee in the discharge of his quasi official duties; but as the representative of the creditors his duties as such representative must be discharged, not as an officer of the court, strictly speaking, but as provided in the bankruptcy act."

He is not, like a receiver, a mere caretaker and manager of the estate to execute the orders of the court in the progress of administration, but he is the agent of the creditors, selected by them as a man of affairs to conduct the business of collecting the assets and distributing the proceeds among the creditors. The statute invests him with the title of the bankrupt, and makes him not only quasi owner, but the owner pro hac of all the property and rights of action belonging to the bankrupt. The management of the estate is committed to his discretion, and he is expected to exercise his powers and discharge his duties with the same intelligence that an owner would do, subject, of course, primarily, to the supervision of the creditors in their meetings called for the purpose, and the whole administration subject to the supervision of the court of bankruptcy. The proceedings are not conducted, like insolvency proceedings in the chancery courts of Tennessee, by a receiver, under the constant orders of the court, and who can do nothing, scarcely, without the previous direction of the chancellor; but the proceedings in bankruptcy are to be conducted according to the specific directions of the bankruptcy statutes and the rules and the forms prescribed by the supreme court. It is a comprehensive scheme of administration by the creditors through their trustee, with which the court interferes as little as possible. He may employ counsel, using such judgment as an ordinary man would use in the transaction of his own business (*In re Abram* [D. C.] 103 Fed. 272, 4 Am. Bankr. R. 575); and he may apply to the creditors for authoritative advice and instructions, and for assistance with money if in the conduct of litigation he be without funds (*In re Arnett* [D. C.] 112 Fed. 770). Under such a statutory system as this the necessity for applications to the court for its instructions and advice should be very rare, and would arise only under somewhat extraordinary circumstances.

As appears from this record, the real question in this case is whether or not, upon a proper application by the trustee, the bank should not have its proof of claim entirely expunged and disallowed because of the alleged fraud set forth in petition offered to be filed, and be required to refund the whole of the dividends which it has received, and be not allowed to participate in the assets at all, leaving the collaterals in its hands for what they may be worth; or, if the creditors shall so determine, they might direct the trustee to compromise this demand upon the bank by allowing it to surrender its collaterals and prove its whole debt, as the bank offers to do in this record by the tender that was made to assign the decree for the collateral notes to the trustee; or to make any other settlement:

that may be agreed upon between the bank and the creditors, notwithstanding the alleged fraud. It is not impossible that the bank may be able satisfactorily to explain the circumstances, and relieve itself of the imputation of fraud such as would justly forfeit its right to prove its claim under section 57 of the bankruptcy statute. And what is here said has been said with a full understanding that the bank has not yet been heard to make such explanation. It is open to the bank and to the creditors to settle these matters through the action of the trustee under the guidance of the creditors' meeting by any compromise they may agree upon. Or the creditors may instruct the trustee to proceed to expunge the claim of the bank, and insist upon the right of forfeiture of any share in the assets. The referee undertook, without any application by the trustee to that end, or without his consultation with the creditors, to accept the informal tender of the bank of its recovery against the landholder to enforce the lien of the collateral notes, and leave the bank to retain its dividends already received, and to take such other dividends as may be coming to it on such a settlement. There are no proceedings before the referee that would authorize him or the court to take such action. The trustee did not ask the court for instructions generally as to what he should do with this controversy with the bank, but only to be instructed whether he should sign a proposed petition in his behalf, prepared by his counsel or the counsel for the creditors; and that was the only question before the referee. It did not yet present a case, nor any occasion for an adjudication of the rights of the trustee against the bank; and the decision of the referee should have gone no further than to advise the trustee whether he should take the particular proceedings against the bank as suggested. And that was a question that ought to have been left by the referee's decision to the trustee's own discretion, under his responsibility to the creditors and the court for the wrongful exercise of that discretion; or else he should have been advised to apply for a meeting of the creditors to submit to them the decision of the question as to what steps should be taken against the bank, or whether a compromise should be made, and, if so, what compromise, just as was done in the case of Arnett, *supra*, to the rulings of which in such matters I desire to adhere, where the estate is of sufficient value to justify the expense.

It may be remarked that the theory of the petition propounded by the trustee, also that indicated by the tender of the bank, and possibly the theory accepted by the referee, namely, that the bank was under an obligation to surrender its securities, does not certainly appear upon the facts shown in the record to be tenable. The petition, on the face of it, does not set up any facts showing a fraudulent preference, and the assignment of the collateral notes to the bank appears to have been more than four months before the bankruptcy, and, if the circumstances were such that the assignment of the collaterals to the bank was a fraudulent preference outside the four-months limitation, the petition has not been definitely drawn to show or plead that fact. It is, however, unnecessary, in the view the court has taken of the case, to consider that question, as it will be

open to the trustee to shape any petition he may hereafter file against the bank as he may be advised, and claim any relief to which he may possibly be entitled. Much may depend in the exercise of his discretion upon the value of the recovery that has been had upon the collateral notes by the decree of the chancery court in its relation to the value of the land. It may be worth less than the amount of the decree, and very little, after paying the expenses of the litigation, including the attorney's fee as provided in the tender of the bank. It may be a mere empty offer on the part of the bank. This matter requires careful attention by the trustee and his legal adviser, and by the creditors at any meeting that may be called to consider the proposals made by the trustee, under the guidance of his legal adviser, to the creditors. Also it will require that the trustee and his legal adviser shall carefully determine whether this offer of the tender by the bank is one of mere compromise, or one of obligation on the bank to make and the creditors to accept. It will require, too, the careful attention of the trustee and his legal adviser to determine whether the trustee can claim for the creditors both a return of the dividends and a surrender of the collateral notes, now in the form of the decree recovered in the chancery court; or whether the trustee's remedy, outside of a mere compromise with the bank, is not strictly confined to a demand for a return of the dividends paid to the bank, and the expunging of the bank's proof of debt alleged to have been fraudulently made, and the consequent total disallowance of any share in the assets by the bank because of that alleged fraud. The holding of the referee that the petition proposed does not sufficiently plead any fraud on the part of the bank might be met by the fact that the circumstances showing the fraud are pleaded, and it is not necessary to use mere epithets to properly plead it. The petition states the facts of concealment, and it would be for the bank to show by its answer how the concealment could be otherwise than intentional. And, if intentional, it would be fraudulent, whether the bank knew it to be so or not, as all are presumed to intend the consequences of their unlawful act. Ignorance is not always a defense against unlawfulness; nor are good motives; and cannot always condone the injury done to the victim of the wrong that was done.

The court is of opinion that the referee was not authorized to decide any of these questions as the record was made before him, and that their decision here would be premature. They can only be made upon proper pleadings, issues, and proof, in a litigation between the trustee and the bank by petition and answer in the bankruptcy proceedings. An order will be entered to set aside the rulings of the referee, and dismissing the application of the trustee for the advice and instructions of the court in the premises, leaving him to take such action as he may be advised by counsel or a meeting of the creditors. Any creditor aggrieved by any neglect or refusal of the trustee to properly discharge his duty in the premises may apply to the court for his removal and the substitution of a trustee who will not hesitate to perform his plain duty under the bankruptcy statute.

Ordered accordingly.

DRESSEL et al. v. NORTH STATE LUMBER CO.

(District Court, E. D. North Carolina. December 13, 1902.)

1. BANKRUPTCY—EXCEPTIONS BEFORE REFEREE.

Exceptions taken before a referee in bankruptcy must be specific, as required by the settled practice of the federal courts.

2. SAME—CLAIMS—RIGHT TO CONTEST.

Only creditors of a bankrupt whose claims are allowed have any standing to contest the claims of others.

3. SAME—PREFERENCES.

A payment received by a creditor of a bankrupt from a third party, and which did not come out of the assets of the bankrupt, does not constitute a preference.

4. SAME.

A bank advanced money on a check drawn by a corporation, which afterward became a bankrupt, with the express agreement that the money was to be used only for a particular purpose. It was not so used, and was later returned to the bank in payment of the check. *Held*, that such transaction did not constitute a preferential payment, so as to affect other claims of the bank against the estate in bankruptcy.

5. SAME—PROCEEDINGS BEFORE REFEREE—OBJECTIONS TO EVIDENCE.

A referee in bankruptcy is governed by the rules in equity in taking testimony, and is not authorized to excuse a witness from answering questions on objection thereto.

6. SAME—FEES OF REFEREES.

A special allowance to a referee for services performed, in addition to the fees fixed by the bankruptcy act, cannot be made, even with the consent of the attorneys for the parties in interest.

In Bankruptcy. On review of report of referee.

Graham & Graham, for petitioners.

Manning & Foushee and Guthrie & Guthrie, for other claimants.

PURNELL, District Judge. After the former decision in this cause, March 11, 1901 (107 Fed. 255), other creditors joined in the petition, and without objection the North State Lumber Company was on August 20, 1902, adjudged a bankrupt, and the cause referred. Under the original order (see above citation) made in the cause the petitioners took depositions in support of their claims, which depositions seem to be full. After the adjudication the parties were before the referee, and the case is now before this court on the report or what purports to be the report of the referee. This report is defective in many particulars, especially in that the referee does not state his findings of fact and conclusions of law, but certifies the depositions, book of proceedings, and papers filed, in which the questions raised on the hearing appear when pointed out. Possibly the cause should have been re-referred for a proper report, but on account of official engagements the record was not examined until counsel had argued the case. It appears from the argument, and what can be gleaned from the record, that two claims are contested: First, the claim of I. N. E. Allen & Co., amounting to \$7,630.60, divided up by assignment as follows: Edw. A. Pierce, \$284.76, Fred. H. Dressel, \$367.10, Eugene F. Perry, \$5,999.55, and I. N. E. Allen & Co. \$999.42; second, the

¶ 2. See Bankruptcy, vol. 6, Cent. Dig. § 526.

claim of the First National Bank of Durham for \$2,485.92. The objections to the first claim, as divided up, was sustained, and the claim disallowed. The second claim was allowed by the referee.

The claims of I. N. E. Allen & Co. and their assignees, as set out above were objected to on the ground that neither were creditors of the North State Lumber Company, but, on the contrary, the said I. N. E. Allen & Co. was indebted to the bankrupt, and a suit involving the settlement of this contention is now pending in the courts of New York. Taking all the testimony and documentary evidence, it appears the dealings between the bankrupt and I. N. E. Allen & Co. were without financial basis, and what is known in commercial circles as "kiting." To go into the mystic details of these dealings has made a voluminous record, from which it is exceedingly difficult to eliminate facts. The claims classified above all depend upon the dealings between the bankrupt and I. N. E. Allen & Co., who did business at 31 Nassau street, New York, as wholesale dealers in lumber. I. N. E. Allen, who resided in New York, was an officer of the bankrupt corporation at Durham, N. C. E. A. Pierce frequently signed the checks and drafts of I. N. E. Allen & Co. From a careful examination of a complicated record and account, it appears and is found as a fact that I. N. E. Allen & Co. were financiering a bankrupt corporation, and adopted a system by which the corporation did not get ahead of them, and at the time of the filing of the petition and at the time of the assignment of the claims above, instead of being indebted to I. N. E. Allen & Co., the said I. N. E. Allen & Co. were indebted to the North State Lumber Company. Therefore the decision of the referee disallowing these claims is affirmed.

The exception to the ruling of the referee refusing to allow these claimants further time to take depositions in New York is overruled. As before said, the depositions seem to be full. Ample time was allowed for the taking thereof,—six or eight months,—and it was understood by the parties from the initiatory steps in this cause that their claims were contested. Many exceptions in the record it is unnecessary to notice in detail. They are what are termed "broadside" exceptions. Exceptions must be specific. This is too well settled in the United States courts to require the citation of authority. For the purpose of appeal, if parties are so advised, these exceptions are overruled.

The claim of the First National Bank was originally \$10,496.42, including two accepted drafts, which appear to have been assigned to Wilson R. Hunter for \$4,010.50 and Sydney C. Chambers for \$4,000; total \$8,010.50. These drafts were stricken from the claim by order of the referee, to which ruling the bank excepted. This ruling of the referee is affirmed. The objections to the proceedings before the referee for not granting time, etc., were matters of discretion with the referee, and, it not appearing it worked an injustice to even parties making such objection, but the facts were fully disclosed, such objections are without force.

The bank, after deducting claims which it had assigned, was permitted to prove a claim for \$2,485.92, which is made up as follows: A draft for \$185.35, drawn by A. G. Fleming on the North State Lumber

Company Sept. 25, 1900, at three months, duly accepted and paid by the bank; an acceptance of the North State Lumber Company indorsed by A. G. Fleming, at three months, for \$612.10; acceptance of North State Lumber Company indorsed by A. Max, ninety days, for \$396.06; a note for \$1,250, drawn by I. N. E. Allen & Co., indorsed by the North State Lumber Company, and discounted by the First National Bank; an overdraft of the North State Lumber Company for \$42.40, maturing December 1, 1900. The claim of the First National Bank was objected to by Frederick H. Dressel, I. N. E. Allen, and others, which objections were answered by the assertion these parties were not creditors of the bankrupt. This the referee found to be true, and the court affirms such findings. Not being creditors, their claim not allowed, they had no interest in the bankrupt estate or interest in the funds thereof; hence no right to be heard. It is not for parties not interested to interject objections in bankruptcy proceedings. They might be heard by permission of the court, under the equity rules, upon it appearing they had a bona fide interest in the fund; but they had no such interest.

The bankrupt corporation, in the assignment complained of as an act of bankruptcy, acknowledged itself indebted to the bank in a much larger sum than that now allowed, which indebtedness has been materially reduced by the withdrawal of notes which seem to have been assigned before the petition was filed. The objections were based on the allegation the bank had received a preference by payments on a claim of said bank against I. N. E. Allen & Co. and H. L. Garwood, upon which claim the bank had entered suit, and \$800 was paid to the attorney for the bank within four months of the filing of the petition in bankruptcy by one of the defendants. This \$800 was paid by check to J. S. Manning, Esq., attorney, not by the bankrupt, not out of the assets of the bankrupt estate, but upon a separate and distinct commercial paper. The acceptor on commercial paper is the principal debtor, the presumption being he owes the drawer of the draft, and one who discounts such paper may elect to sue such acceptor as principal, or the drawer of the draft as surety. But the payment was not by the bankrupt, and in no way reduced the assets of the bankrupt estate. It in no way worked an inequitable distribution of the bankrupt's assets, and could in no way be a preference. The money was paid by Garwood, not out of the bankrupt estate. H. L. Garwood signed a note at three months, payable to I. N. E. Allen & Co., for \$803.51, August 22, 1900. This note was discounted by the First National Bank, and the amount placed to the credit of the North State Lumber Company. Why, does not appear. The name of the lumber company does not appear in or on the note. Suit was entered on this note, and the \$803.17 was paid to J. S. Manning, attorney for the bank. Counsel claim this was a preference, but the court is unable to understand why, as the bankrupt was in no way connected with the payment or the suit. The bank acquired title to the note when the money was paid a year or more before the petition was filed, and the lumber company was in no way connected therewith.

There was another transaction, claimed by creditors represented by P. C. Graham, Esq., to be a preference, but this was not pressed in

the argument, and there is no force in the position that it is a preference. The facts are as follows: By an express agreement between Cochran, the president of the North State Lumber Company, and the First National Bank of Durham, a check (No. 566), drawn for \$3,500, by the North State Lumber Company, Limited, by John R. Cochran, president, payable to the order of John R. Cochran, and indorsed as follows: "John R. Cochran. North State Lumber Co., by John R. Cochran, President. Manufacturers' National Bank of Baltimore, Murchison National Bank of Wilmington, and the Fidelity Bank of Durham." This check was presented for payment on October 30th, and paid on the 31st of October. The check was given for a specific purpose, and was to be placed in the Manufacturers' National Bank of Baltimore to the credit of the North State Lumber Company in that bank, subject to the check of J. S. Manning, attorney for the North State Lumber Company. It was deposited there as the basis of a loan that they were to make through the Manufacturers' Bank, which was not made, and the money was withdrawn from the bank by the check of J. S. Manning, attorney of the North State Lumber Company, and placed to the credit of the North State Lumber Company in the First National Bank of Durham, N. C., to pay the check No. 566, drawn on the First National Bank, and the proceeds of check No. 566 for \$3,500 was returned to the First National Bank in that way. It was also agreed between Cochran and the First National Bank of Durham that the money should be placed in the Manufacturers' National Bank in the way indicated for the purpose of preventing any use of the money in any business of the North State Lumber Company. Witness testified, "The money was put there first to obtain the loan, and the loan was not granted, and the money was placed back where it originally came from." The whole transaction was in two checks.

The overdraft of \$42.50 is also argued as a preference, and many decisions cited to sustain the objection. Had the bank been the bankrupt, this would have been a preference; but this is not the case. The bank is the creditor. The overdraft did not effect a benefit in its favor to the detriment of other creditors of the North State Lumber Company, but increased the assets, on paper, of that corporation to this amount. The object of the Bankrupt Act, § 60 [U. S. Comp. St. 1901, p. 3445], as said by the supreme court in *Pirie v. Trust Co.*, 182 U. S. 438, 21 Sup. Ct. 906, 45 L. Ed. 1171, so far as creditors are concerned, is to secure equality, in the distribution, among all, of the property of the bankrupt. There are many decisions to the same effect (some of them cited on the argument) by other courts, but this decision of the supreme court is the test. The objections urged and noted, thus tested, are not a preference under the statute. It does not appear the bank has received any property or money belonging to the bankrupt which gives it a preference,—an unequal, inequitable share of the assets of the bankrupt. The claim of the bank as noted is allowed.

There are many exceptions to the ruling of the referee, some of which should be sustained; for instance, the referee, on simple objection, excuses witnesses from answering questions, notably the cashier of the bank. The referee should have noted the objection and answer,

and reported the facts as they occurred. Referees are governed by the rules in equity in taking testimony. These exceptions in the record were not, however, pressed in the argument, and do not seem to have affected any substantial right of petitioner who made the objection. The facts necessary to a determination of the controversy fully appear. Hence it is deemed unnecessary to remand the cause, and further complicate it.

Since the hearing a petition has been presented, attested by the consent of attorneys of all the parties asking for an order to pay certain claims for labor and cost of preserving the estate after the petition was filed; also an allowance of \$150 to W. K. Yates, referee. Under section 64b, subs. 1-4 [U. S. Comp. St. 1901, p. 3447], actual and necessary cost of preserving the estate subsequent to the filing of the petition and wages to workmen which have been earned within three months are given priority, and may be paid without consent. An order will be entered providing for the payment of these claims by drafts drawn under general order 29 (32 C. C. A. xxviii, 89 Fed. xii).

A special allowance to a referee for services performed under the statute cannot be made, even with the consent of attorneys. The fees fixed by statute are in full compensation. General Order Sup. Ct. 35 (18 Sup. Ct. ix); Bankr. Act, § 40. The consent of attorneys would not justify the court in reading into the statute what congress failed to put there, or in violating the provisions of the act as construed by the supreme court. The order for a special allowance is refused. Referees are entitled to the fees allowed in the bankrupt act for services required under the act, and will be allowed none other for such services.

PEOPLE OF STATE OF CALIFORNIA ex rel. BRADY v. BROWN'S VALLEY IRR. DIST. et al.

(Circuit Court, N. D. California. November 3, 1902.)

1. REMOVAL OF CAUSES—FEDERAL QUESTION—QUO WARRANTO PROCEEDING BY STATE.

An action in the nature of quo warranto to determine the right of an organization to exercise the functions and franchises of an irrigation district under the laws of California, in which the information of the attorney general recites the proceedings by virtue of which defendant claims to have been organized as an irrigation district, and charges that they were not in conformity to the laws of the state authorizing the organization of such districts, but were in violation of the same and of the constitution of the state, is not one arising under the constitution of the United States, and removable into a federal court on that ground, because it is also charged as a further ground of illegality that the acts of defendant were in violation of certain provisions of the federal constitution.

2. SAME.

Nor does an allegation in such information, in effect, that if the law of the state known as the "Wright Act," under which the defendant was professedly organized, authorized the proceedings taken, such act was void, as in violation of the provisions of the constitution of the United

¶ 1. Jurisdiction in cases involving federal question, see notes to *Bailey v. Mosher*, 11 C. C. A. 308; *Montana Ore Purchasing Co. v. Boston & M. Consol. Copper & Silver Min. Co.*, 35 C. C. A. 7.

States, state a controversy with respect to a federal question, which gives a federal court jurisdiction, since such question is only contingently involved; and, moreover, the Wright Act has been adjudged constitutional by the supreme court of the United States, and its constitutionality is therefore no longer a federal question.

W. H. Chamberlain, for plaintiff.

Rosenbaum & Scheeline and W. H. Gregory, for defendants.

MORROW, Circuit Judge. This is an action brought by the attorney general of the state of California, on the relation of Arthur J. Brady, to obtain a decree declaring that the Brown's Valley irrigation district, unlawfully and without right, claims to be, and acts as, and usurps, intrudes into, and unlawfully exercises the functions and franchises of, a public corporation; that it be excluded and enjoined from exercising the corporate powers and franchises of a public corporation and an irrigation district; and that it be abated. The action was commenced in the superior court of the county of Yuba, in this state, and, upon the petition of the defendants, was removed to this court.

The petition alleges that the action involves a question arising under the constitution of the United States. This question is stated in the petition, as follows:

"It is claimed by plaintiff in said complaint, on page 8 thereof, commencing with line 5 and ending with line 13 thereof, that 'the said printed notice was for said reasons, in addition to other reasons herein alleged, insufficient, illegal, null, and void, and constituted no notice whatever, or any process of law, and the same and all of the proceedings subsequent thereto, based and formed thereon, which are herein alleged, were and are, and each and every one of them was and is, without jurisdiction and void, and in violation of section 13 of article 1 of the constitution of the state, and of article 5 of the amendments to the constitution of the United States'; and it is claimed by the plaintiff in said complaint, on page 51 thereof, commencing at line 13, 'that on account of facts herein alleged, and for reasons herein given, said Wright act, so far as the same relates to or affects said alleged Brown's Valley irrigation district, and at all times since the passage thereof, was and is in violation of the provisions of articles 5 and 14 of the amendments to the constitution of the United States'; and it is claimed by said plaintiffs that the organization of said Brown's Valley irrigation district was in violation of the provisions of articles 5 and 14 of the amendments to the constitution of the United States."

It is contended on the part of the defendants that it appears from this statement of the plaintiffs' claim that the case is one arising under the constitution of the United States. The allegations of the complaint do not, however, support this claim. The action is in the nature of a quo warranto proceeding to determine the right of the defendant Brown's Valley irrigation district to exercise the functions and franchises of a public corporation under a law of the state, and the charge in the complaint is that it—

"Does now, unlawfully and without right, claim to be, and is acting as, and is usurping, intruding into, and unlawfully exercising the functions and franchises of, a public corporation, to wit, an irrigation district, and is now claiming, and has claimed, during all of said time, unlawfully and without right, to be legally organized and existing as such irrigation district, under and by virtue of the provisions of an act of the legislature of the state of California, entitled 'An act to provide for the organization and government of irrigation

districts, and to provide for the acquisition of water and other property, and for the distribution of water thereby for irrigation purposes,' approved March 7, 1887, commonly known and hereinafter designated in this complaint as the 'Wright Act,' and under and by virtue of the several acts of the legislature amendatory thereof or supplementary thereto, but that said Brown's Valley irrigation district has never been, and is not now, legally, or at all, organized or existing in compliance or in accordance with the provisions of said Wright act, or organized or existing at all as such irrigation district."

The complaint then proceeds to recite the proceedings under which the defendant claims to have been organized as an irrigation district under said Wright act, namely, the signing of the petition by certain persons, praying for the organization of an irrigation district; the publication of the petition; the publication of the notice stating the time when said petition would be presented to the board of supervisors of Yuba county; the presentation of the petition to the board, accompanied by a bond conditioned for the payment of the costs of organization of the district, and also by an affidavit of publication of the petition and notice; the hearing of the petition by the board of supervisors; the exclusion of certain lands by the board; the order made by the board for the purpose of changing certain boundaries of the district, and to establish its boundaries, and to call an election for the purpose of determining whether or not such irrigation district should be organized; the publishing of a notice of such election; the holding of an election; the canvassing of the votes cast at such election; the declaration of the result thereof by the board of supervisors; the order of the board of supervisors declaring the territory duly organized as an irrigation district under the name of "Brown's Valley Irrigation District"; and the recording in the office of the county recorder of Yuba county of a certified copy of said order. These proceedings, it is alleged, were in pretended compliance with the provisions of the Wright act, but were in fact contrary to its requirements, and were unlawful and without right or authority of law whatever. In paragraph 8 of the complaint it is alleged that the pretended notice of the time at which the original petition for organization was to be presented to the board of supervisors was insufficient, constituting no notice whatever, nor any process of law, and therefore all proceedings subsequent thereto based thereon were without jurisdiction and void, and in violation of section 13 of article 1 of the constitution of the state, and of article 5 of the amendments to the constitution of the United States. In paragraph 13 of the complaint it is alleged that the action of the board of supervisors in organizing the said district and establishing the boundaries thereof were without jurisdiction and void, and in violation of the intent and provisions of the Constitution of the state and of the United States. And in paragraph 48 it is charged that on account of the facts before alleged, and for the reasons there given, the Wright act, so far as it relates to or affects the said Brown's Valley irrigation district, is in violation of articles 5 and 14 of the amendments to the constitution of the United States, and also various provisions of the state constitution. But it is also alleged that all these acts were contrary to the provisions of the Wright act.

The allegations of the complaint that the proceedings in organizing the district did not conform to the requirements of the Wright act, and were in violation of the provisions of the constitution of the state, do not, of course, state a federal question; and the further allegations that these proceedings were also in violation of the constitution of the United States do not show that the case is one arising under the constitution of the United States. On the contrary, it distinctly appears that the controversy arises under the constitution and laws of the state; but, probably for the purpose of showing that the proceedings in organizing the district were illegal and void, in whatever jurisdiction they may be brought into question, it is further alleged in the complaint that the proceedings were in violation of the constitution of the United States. This allegation is not sufficient to give this court jurisdiction of the case, as involving a federal question. The allegation that the Wright act, so far as it relates to or affects the defendant, is in violation of the constitution of the United States, also fails to state a federal question. The allegation, in any view, is altogether too general for that purpose. But aside from that objection, the facts alleged in the complaint are all clearly designed to show, not that the Wright act is unconstitutional, but that the proceedings in organizing the district were contrary to its provisions. It may be that the pleader intended to say that, even if the proceedings were held to be in conformity with the Wright act, the act itself was in violation of the constitution of the United States, and therefore for that reason the proceedings were illegal and void. But this form of an allegation does not state a controversy with respect to a federal question that gives this court jurisdiction of the case. Besides, the Wright act has been declared constitutional by the supreme court of this state in *Irrigation Dist. v. Williams*, 76 Cal. 360, 18 Pac. 379; *Irrigation Dist. v. De Lappe*, 79 Cal. 351, 21 Pac. 825; *Board v. Tregua*, 88 Cal. 334, 26 Pac. 237; *In re Madera Irr. Dist.*, 92 Cal. 296, 28 Pac. 272, 675, 14 L. R. A. 755, 27 Am. St. Rep. 106; *In re Central Irr. Dist.*, 117 Cal. 382, 49 Pac. 354. The act has also been held constitutional by this court in *Herring v. Irrigation Dist.*, 95 Fed. 705, 715. It has also been held constitutional by the supreme court of the United States in *Irrigation Dist. v. Bradley*, 164 U. S. 112, 17 Sup. Ct. 56, 41 L. Ed. 369, and *Irrigation Dist. v. Shepherd*, 185 U. S. 1, 22 Sup. Ct. 531, 46 L. Ed. 773. The constitutionality of the Wright act is therefore no longer a federal question. *Montana Ore Purchasing Co. v. Boston & M. Consol. Copper & Silver Min. Co.*, 29 C. C. A. 462, 85 Fed. 867.

It appearing from the complaint in this case that the suit does not really or substantially involve a dispute or controversy properly within the jurisdiction of the circuit court, the case is remanded to the court from which it was removed.

THE LIBERTY.

(District Court, W. D. Tennessee, W. D. August 28, 1902.)

No. 1,068.

1. ADMIRALTY—SUIT TO ENFORCE MARITIME LIENS—DISPOSITION OF SURPLUS FUNDS.

Conceding the jurisdiction of a court of admiralty in a suit in rem to enforce liens against a vessel to direct the payment of maritime creditors who have proved their claims, but have been adjudged without lien, from the remnants remaining in the registry of the court after all liens have been satisfied, as against the owner of the vessel, still such jurisdiction should not be exercised where such owner is an insolvent corporation, represented by a receiver appointed by a state court in insolvency proceedings to wind up the affairs of the corporation; but in such case the remnants should be paid over to the receiver, to be distributed between the maritime and other creditors in accordance with the laws of the state. The admiralty court may, however, if the pleadings are sufficient to support judgments in personam against the owner, determine the amount due each of such maritime claimants, and enter judgment therefor.

In Admiralty.

Turley & Turley, Warrinner & Warrinner, Myers & Banks, L. & E. Lehman, R. O. Johnson, Hunsdon Cary, and Sterling Pierson, for libelants.

T. K. Riddick and W. W. Goodwin, for claimant.

HAMMOND, J. This is an application to have the remnants remaining in the registry after the payment of claims allowed as liens on the vessel paid over to the receiver of the insolvent corporation which owned her. The receiver was appointed by the chancery court of Shelby county on a bill there filed to wind up the insolvent corporation according to the statutes of the state in that behalf. It was filed after the libel in this case was filed, and after the seizure of the vessel in admiralty. But after the decree of sale the receiver came into this court by petition, asking leave to be made a party; that he be allowed to contest the claims of all libelants; and that the proceeds of the sale, after the payment of maritime liens, be paid over to him as such receiver. Among the intervening libelants are several creditors, who claimed a lien on the vessel for supplies furnished in her home port at Memphis, under the statute of the state giving such a lien, but whose lien has been defeated because their claims were not filed within the 90 days fixed by the statute for the continuation of such lien. These creditors ask that their debts be paid out of the fund notwithstanding the expiration of their liens, their contention being that their debts are maritime in their origin, and that a court of admiralty has full jurisdiction to decree their payments. The learned counsel for the claimant in this case have relieved the court of the necessity for determining the niceties of questions that would arise on the facts of this case if it were not for the liberal concession that they make to the libelants, who have lost their liens. I quote from the brief of one of them a paragraph as follows:

"It may be conceded at the outset that the court of admiralty, under well-established rules, has jurisdiction to consider the right of claimants where such rights are founded upon contracts maritime in their nature, to be paid out of the proceeds of sale after all maritime liens are satisfied. It may be conceded that this is true whether the claims are predicated upon a maritime contract which never did constitute a lien upon the ship, or whether they depend upon a contract for which a lien originally existed, but which has been lost either by laches under admiralty law, or a lapse of the statutory period where the lien existed by virtue of the state law. So it makes no difference how the claim is presented, whether by original petition in personam, or by petition in rem which has been dismissed because of the loss of the lien, still the court has jurisdiction to consider the claim, and, as between the owner and the claimant, to hear and determine the rights, and to require payment to be made out of remnants according to the right."

This concession is based upon the rulings in cases like that of *Leland v. Medora*, 2 Woodb. & M. 92, Fed. Cas. No. 8,237, and the approval of that jurisdiction by the supreme court in the case of *The Lottawanna*, 21 Wall. 558, 582, 22 L. Ed. 654. There is no jurisdiction requiring more careful scrutiny than this of a court of admiralty to avoid a usurpation of the jurisdiction belonging exclusively to courts of law and equity, and with which a court of admiralty cannot possibly deal. Indeed, the supreme court says in the *Lottawanna* Case, while declaring the jurisdiction to exist, that, "if a case should be so complicated as to require the interposition of a court of equity, the district court could refuse to act, and refer the parties to a more competent tribunal." That is precisely what happens in this case. It is conceded to counsel for the libelants, who have lost their liens under the statute, and who have maritime claims, that as against the owner of the vessel the court here would give them a judgment for the amount due each of them, and satisfy their claims pro rata or in full, as the case may be, out of these remnants. But the court here does not wish to be bound wholly by that concession as a precedent, for it is made without further discrimination, because counsel for the receiver so liberally grant it for the purposes of this case. The trouble here is that it is not the owner of the vessel against whom this relief is asked. The case is complicated by the fact that the owner is a corporation under the laws of the state of Tennessee, which has become insolvent, and is being proceeded against in the courts of Tennessee under the statutes of that state for winding up insolvent corporations, and it is the receiver of this insolvent corporation who insists that the court of equity appointing him shall distribute these remnants according to laws of Tennessee for winding up insolvent corporations. Under those laws the assets of an insolvent corporation are a trust fund for an equal distribution when there are no liens upon those assets. It is plain that a court of admiralty cannot exercise that jurisdiction and enforce that trust. It is equally plain that a court of admiralty cannot, because it happens to have jurisdiction of a part of the assets of the insolvent corporation by reason of its rightful seizure of one of the vessels of the corporation for the purpose of enforcing maritime liens, create priorities, preferences, or liens to the exclusion of other creditors not before the admiralty court, and who cannot come there to receive their share of the proceeds. Those maritime creditors who have lost their maritime liens under the statute have under the in-

solvent corporation laws of Tennessee no greater or other right to be paid out of the assets than have the common-law creditors. If we should pay the maritime creditors here out of these remnants, we would, in effect, give them a lien over the common-law creditors to which they are not entitled under any law, common or maritime, nor under the statute of Tennessee; or at least we should be giving them a preference over the common-law creditors, to which they are not entitled; or, unless we should undertake to ascertain their pro rata share along with the common-law creditors, we might pay them more than they are entitled to receive. It is obvious that this court cannot protect the statutory and equitable right of equal distribution among all the creditors of this insolvent corporation without usurping the jurisdiction that belongs to the court of equity operating under the Tennessee statute for winding up insolvent corporations. It is the very case indicated by the supreme court in the Lottawanna Case where the district court should refuse to act, and refer the parties to a more competent tribunal. It may be well enough to remark that the case is not of that kind where a court, having obtained jurisdiction for one purpose, will keep it for all purposes, to avoid further litigation and a multiplicity of suits. If that principle ever applies to a court of admiralty so as to authorize it to exercise common-law or equitable jurisdiction, it surely does not authorize the incongruous jurisdiction which would be found in operation if a court of admiralty should undertake to wind up an insolvent corporation under the statute of a state, either wholly or only as to a part of the assets of the corporation which happens to be found in the court of admiralty as remnants. The case of *The Edith*, 5 Ben. 432, Fed. Cas. No. 4,282, affirmed 11 Blatchf. 451, Fed. Cas. No. 4,283, and again affirmed by the supreme court, 94 U. S. 518, 24 L. Ed. 167, fully sustains the ruling we here make, if it does not go further, and deny the right of any one to be paid out of the remnants in admiralty, even against the owner, unless he has a lien. It is not necessary to decide that question in this case, since counsel for the receiver concedes that it may be done as above stated.

A difficulty I have had in dealing with this case in this view of it relates to the right of the libelants who have lost their liens under the state statutes to have this court to declare, nevertheless, the amount due to each of them. They have a maritime claim, and this court, upon a proceeding in personam, might give them a judgment in personam for what is due to each. This is not a proceeding in personam, and these intervening libelants have not proceeded in personam. Whether their libels intervening in a proceeding in rem may be turned into libels in personam to support a judgment of that character may be doubtful, but they certainly will support a petition to be paid out of the remnants, and, if that jurisdiction exist, certainly this court has a right to determine the amount that is due in some form of action; and, since the receiver takes no objection to these pleadings on the score of their insufficiency to support a declaration of the amount that is due, I have concluded to give a judgment here against the claimant, the receiver in this case, for the amount that is due to each of those libelants, so that they will be saved the expense of proving their claims again in the insolvency court, to which they must resort to receive their pro

rata share of this fund, unless that court shall require otherwise. The clerk will therefore enter a decree declaring the amount found due each of the intervening libelants according to his report; that is to say, for those libelants who have lost their liens under the state statute by failing to file them within the 90 days required by law. The remnants will be paid to the receiver.

Ordered accordingly.

=====

In re ROOSA.

(District Court, N. D. Iowa, Cedar Rapids Division. December 12, 1902.)

1. BANKRUPTCY—CONCEALMENT OF ASSETS—FRAUD—REVOCATION OF DISCHARGE.

May 14th the father of a bankrupt died, leaving a will bequeathing so much of his property as might be left after his wife's death to be equally divided among his children. June 18th, and after the probate of the will, the petition in bankruptcy was filed, no reference being made to the bankrupt's interest under the will. September 21st the bankrupt conveyed by warranty deed her interest in the estate, the consideration being more than sufficient to satisfy her liabilities. Notice of the proceedings in bankruptcy and of the application for discharge were sent to an objecting creditor at a wrong address, though the bankrupt had lived for many years in the creditor's neighborhood, and was well acquainted with him. The notice was not received, and the creditor did not learn of the matter until after the discharge had been granted. *Held*, that the facts disclosed such fraud on the part of the bankrupt as to necessitate a revocation of her discharge.

Submitted on application of G. W. Coleman for order revoking discharge heretofore granted to bankrupt.

Clark & Clark, for creditors.

W. G. Watkins, for bankrupt.

SHIRAS, District Judge. From the record of this case it appears that G. W. Coleman is the principal creditor of the bankrupt; that for 30 years he has resided on a farm in Monroe township, Linn county, Iowa, his post office for the past 20 years being the town of Robins; that the bankrupt has lived for many years in the same neighborhood, and is well and personally acquainted with the said Coleman; that, in setting forth in the schedules attached to the petition a statement of her indebtedness, the bankrupt gave, as the residence or post office address of the creditor, the city of Cedar Rapids, Iowa; that the creditor received no notice of the proceedings in bankruptcy nor of the application for a discharge, and did not learn of the fact that the bankrupt had instituted proceedings in bankruptcy until a neighbor informed him that he had seen a newspaper statement of the granting of the discharge, which information he received on the 12th day of September, 1902, the discharge having been granted on the 4th day of September, 1902, and thereupon he duly filed in this court an application for the revocation of the discharge, which was sent to the referee to take the testimony on the issues presented thereby, and the case has been finally submitted to the court on the evidence adduced by the respective parties. As a ground for defeating the petition for discharge, the creditor avers that the bank-

rupt intentionally failed to schedule the interest held by her under the provisions of the will of her father in the property of his estate, which interest she sold for the sum of \$1,000, the sale being made on September 21, 1901. The evidence shows that S. K. Byse, the father of the bankrupt, died on May 14, 1901, at Toddville, Iowa, leaving a will which was duly probated in the district court of Linn county, Iowa, on the 15th day of June, 1901; it being declared in said will that "at my death my wife, Loretta Byse, shall have the use of all the property of which I may die seised, both real estate and chattel property, during her lifetime. At her death the amount she may have left shall be equally divided between my three children, viz., Charity Hepker, Heseekiah Byse, Delilah Roosa, and my grandson Ellin Monison." The petition in bankruptcy was filed on the 18th of June, 1901, but no reference was made in the schedules to the interest coming to the bankrupt under the will of her father. On the 21st day of September, 1901, the bankrupt, for the named consideration of \$1,000, conveyed by warranty deed to Henry Hepker the undivided one-fourth of the realty which formed part of the estate of her father. This sum was far more than was needed to pay off in full the debts scheduled by the bankrupt, but she did not account for the same to her creditors, but subsequently applied for a discharge, without giving notice to the principal creditor.

Some discussion has been had by counsel with respect to the interest taken by the bankrupt under the will of her father in the realty owned by him at the date of his death, but it is not necessary to consider this question at any length. Whatever her interest was it was vested in her when she filed her petition in bankruptcy, and she did not set forth any statement concerning the same in the schedules attached to her petition.

The facts show that in the September following she discovered that she had an interest in the realty passing under the will of her father of such a nature that she was willing to sell the same and to warrant her title thereto. The interest she sold was not one acquired after the adjudication in bankruptcy, but it had been created by the death of her father and the probate of his will before she filed her petition in bankruptcy.

The evidence justifies the conclusion that the proceedings in bankruptcy were instituted for the purpose of enabling the bankrupt to protect the interest coming to her under her father's will from liability for her debts. Even if this be not true, good faith on her part required of her, when she ascertained that she had such an interest in her father's estate that she was enabled to sell the same for an amount exceeding her indebtedness, to have amended her schedules and accounted for the proceeds realized by her, instead of keeping the facts concealed from the court and from the creditors, and securing the granting of a discharge through the device of sending notice of the application for a discharge in such a way as to prevent its reaching the creditor.

As the facts proven show that the discharge was obtained through the fraud of the bankrupt, in sending notice of the application for discharge to Cedar Rapids, Iowa, instead of to Robins, Iowa, the proper

post office address of the creditor; and that knowledge of the fraud did not come to the creditor until after the granting of the discharge, and that the actual facts did not warrant the granting the discharge for the reason that the bankrupt had appropriated and concealed assets of her estate to an amount in excess of all the debts scheduled by her, it follows that the discharge heretofore granted the bankrupt must be revoked and set aside, and the petition therefor must be refused.

NEW YORK PHONOGRAPH CO. v. NATIONAL PHONOGRAPH CO.

(Circuit Court, S. D. New York. November 13, 1902.)

No. 7,719.

1. PARTIES—RIGHT TO MAINTAIN SUIT—EFFECT OF CHAMPERTOUS CONTRACT.

The right of a complainant to maintain a suit is not affected by a contract constituting a third person its agent to prosecute and collect all claims against defendant for a per cent. of the amount recovered, even though such contract may have been champertous.

In Equity. On plea.

Louis Hicks, for complainant.

Howard W. Hays, for defendant.

WALLACE, Circuit Judge. The complainant's right to maintain this action is in no respect affected by its contract with Andem. By this contract Andem was made its agent to prosecute all its claims and demands against the defendant and various other parties, and collect all moneys arising therefrom, and to retain as his compensation a sum equal to 60 per cent. of recoveries; and complainant undertook not to settle or compromise without his consent, and he undertook not to settle or compromise with the defendant for less than a specified sum without the consent of the complainant. Andem could not have maintained an action in his own name against the defendant.

As to the contention that the agreement was champertous, even if the law of champerty were in force in this state and if the agreement were void, the complainant would not be precluded from maintaining an action not founded upon the agreement.

The plea is overruled, with costs.

AMERICAN NAT. BANK OF DENVER v. WATKINS.*

(Circuit Court of Appeals, Seventh Circuit. October 7, 1902.)

No. 783.

1. TRIAL TO COURT—SPECIAL FINDINGS.

A special finding made by a circuit court, where a jury is waived by stipulation, pursuant to Rev. St. § 649 [U. S. Comp. St. 1901, p. 525], should state the ultimate facts on which the law must determine the rights of the parties, and should not contain a statement of the evidence.

2. SAME—CONCLUSIVENESS OF FINDINGS ON APPEAL.

A special finding which states the ultimate facts is conclusive upon the appellate court, even though it contains, in addition, statements of evidence and inferences therefrom.

3. SAME.

A special finding that plaintiff was not a bona fide purchaser of a note for value, but took the same subject to any defense affecting the consideration, is one of fact, and not reviewable on appeal as a conclusion of law.

4. PROMISSORY NOTES—FAILURE OF CONSIDERATION.

Defendant was an indorser on notes of a third party, which were also secured by collateral, and by a junior mortgage on real estate of the maker. At defendant's suggestion, but without any agreement that they should be acquired for his benefit, the payee purchased the prior mortgages, some of which were in process of foreclosure, and bid in the property thereunder, subject to a first mortgage which it also held. Subsequently a written contract was made between the parties, by which defendant executed his own notes, covering the entire indebtedness of his principal, and the amount expended by the payee in acquiring the property and liens; and the payee agreed to convey the property, and assign all the securities held by it, including the first mortgage, to defendant, and a deed was executed and deposited in escrow to await the termination of certain litigation affecting the title. In this situation the payee undertook, of its own volition, to foreclose the first mortgage, and in doing so lost title to the property, and also the proceeds of the mortgage, through the insolvency of its agent. *Held*, that the contract was one of bargain and sale of the property and securities, which bound the seller to convey as good title as it then had, and that its loss of title constituted a partial failure of the consideration for defendant's notes.

5. SAME—DEFENSES—PARTIAL FAILURE OF CONSIDERATION.

Under the modern American rule, a partial failure of consideration may be pleaded as a defense in an action at law on a note.

6. APPEAL—REVIEW—HARMLESS ERROR.

A judgment will not be reversed for technical errors in rulings on the admission of evidence which were not prejudicial.

In Error to the Circuit Court of the United States for the Eastern District of Wisconsin.

This action is brought to recover a balance of \$6,000 claimed to be due upon a note of \$16,000, dated January 20, 1892, made by the defendant in error to William Barth, payable four years after date. Barth was president of the City National Bank of Denver, and it is alleged that he transferred it to the bank, which in turn transferred it to the plaintiff in error. The defense is: First, that the plaintiff in error is the successor of the City National Bank, taking its assets and assuming its obligations, but did not take the note as a purchaser for value; second, that the City Bank was the real beneficiary and payee of the note, the consideration for which note was the execu-

* Rehearing denied January 6, 1903.

¶ 5. See Bills and Notes, vol. 7, Cent. Dig. §§ 1373, 1374.

tion and delivery by Barth and the City National Bank of Denver to Watkins, prior to the maturity of the note, of a good, sufficient, clear, and perfect title to certain described real estate in the county of Huerfano, Colo.; that neither Barth, nor the City National Bank, nor the plaintiff in error, nor either of them, have conveyed or offered to convey such title, but have refused so to do, whereby the consideration for the note has failed; and that Watkins had paid upon the note the sum of \$10,000. A jury was waived, and the cause was tried to the court. The trial judge filed special findings of fact and of law as follows:

"First. On or about the 20th day of January, 1892, at Denver, in the state of Colorado, the defendant, Samuel W. Watkins, executed and delivered unto one William Barth, then and now a resident of said state, his certain promissory note in writing, dated on said day, whereby he promised to pay to the order of the said William Barth the sum of \$16,000 four years after the date of said note, together with interest thereon at ten per cent. per annum from the date of said note until paid.

"Second. The said defendant paid on the principal of said note on the 29th day of January, 1896, the sum of \$10,000, together with all interest on said note to said date; and the time of the payment of the balance of the principal of said note without interest was extended to the 15th day of February, 1897, since which date no payment of principal or interest thereon has been made by or on behalf of said defendant.

"Third. The said William Barth, payee in said note, was at the date of the making thereof, and for some time prior thereto and thereafter, president of the City National Bank of Denver, and received the said note for the use and benefit of said bank. The plaintiff therein some time during the month of May, 1894, became the holder of said note, as successor to the said City National Bank of Denver, the assets and liabilities of which said National Bank of Denver the plaintiff assumed, and then obtained and now holds the said note subject to any defense existing in favor of said defendant affecting the consideration thereof. The said plaintiff did not acquire said note as a bona fide holder for value, without notice of the equities subsisting between the parties thereto.

"Fourth. The above-mentioned note was executed and delivered under the facts and upon the consideration as follows, and not otherwise: On and prior to March 28, 1891, the defendant was obligated to the said City National Bank as surety or indorser on several notes made by one T. F. Martin, amounting in the aggregate to about \$20,000, for which said bank further held as security certain collaterals given by said Martin, and also a trust deed upon certain real estate, which was subordinate, however, to three prior trust deeds or mortgages upon such real estate. Such indebtedness being unpaid, the defendant suggested and requested that the bank purchase in the prior incumbrances on the real estate and certain collaterals therewith, held by Thurlow, Hutton & Williams, representing that the value of the property would more than repay the debt and investment, and that the defendant would furnish \$6,000 of the purchase money required for that purpose, to be applied in the purchase of a specific collateral thereof, not involved in the present controversy. Accordingly, on March 28, 1891, such purchase was made in the name of said William Barth, as purchaser, through one J. P. Heisler, acting on behalf of said bank as its attorney, the price paid being \$17,475.60, of which \$6,000 was paid by the defendant, and the remaining sum by the bank; and pursuant to foreclosure notices then pending upon the second and third mortgages, on March 30, 1891, the real estate thereunder was bid in by said attorney in the name of said Barth, and conveyance so taken thereupon. By such transaction title in fee simple was acquired by said Barth (together with other matters) for the use and benefit of said City National Bank of Denver, to the following described real estate situated in the county of Huerfano, state of Colorado, as described in such second and third mortgages and foreclosed as aforesaid, to wit: All the lands, tenements, rights, titles, interest, and privileges of, in, and to the Lake Miriam Ditoh, and all reservoirs in connection therewith, together with lots 1, 5, 9, and 11 in block 50, and 25 feet off the south side of lot 5 in block 33, and lots 7, 11, 12, 13, and 14 in block 4, and all in the town of Walsenburg, Huerfano

county, Colorado, according to a map of the same now on record in the recorder's office of said Huerfano county, Colorado, together with the south half of the northeast quarter and the north half of the southeast quarter of section 13, township 28 south, of range 67 west; and said Barth, for said bank, further became the owner of a \$5,000 note of said Martin, and a trust deed securing the same, upon the same premises above described, which constituted a first lien, but was not included in the foreclosure. Said Barth owned said above-described real estate and prior mortgage, with no promise or obligation on his part or on the part of said bank to sell or otherwise dispose of the same to said defendant. On or about the said 20th day of January, 1892, an agreement in writing was entered into respecting the same, as follows, to wit:

"Memorandum of an agreement made and entered into this 20th day of January, 1892, as follows: The party of the first part herein, being William Barth, the City National Bank, and John R. Hanna, of Denver, Colorado, acting either individually or collectively, as the case may be, and the party of the second part herein being S. W. Watkins, of Walsenburg, Colorado. Whereas, during 1890, and possibly at other times, one T. F. Martin, and said S. W. Watkins became indebted to the said party of the first part in the sum of about twenty-one thousand (\$21,000) dollars, which was then or afterwards secured, in part only, by certain collaterals and trust deeds on certain property situated in Huerfano county, Colorado; and whereas, the said property so given as security or part thereof had also previously been given as security for certain indebtedness due from said Martin to Thurlow, Hutton & Williams, or some one or more of said persons, of Colorado Springs, Colorado, the evidence of indebtedness of said Martin to said T., H. & W., and the collaterals which belong to or were connected therewith, being afterwards bought by the said party of the first part herein, about March 30, 1891, for the sum of about \$17,500, said second party having advanced part of the same, so that there is due to said first party on account of matters above mentioned, with interest thereon, at this time, about thirty-five thousand four hundred and thirty-seven and twenty-two one-hundredths (\$35,437.22) dollars; and whereas, certain of the said collaterals given to secure the debt due to said first party, and certain collaterals and real estate given to secure the debt formerly due to T., H. & W., and afterwards purchased by said first party, having been foreclosed and sold, the same having been bought in by the said first party: Now, therefore, it is agreed that said second party shall execute his note, payable to Mr. William Barth, one of the said first parties above named, for the full amount of thirty-one thousand (\$31,000) dollars, and delivered to said first party upon the execution thereof, cash in hand, and notes as follows, to wit: One note due in two years for \$15,000, one note due in four years, \$16,000, with interest at ten per cent. per annum; pay cash to the amount of \$4,437.22; making a total of \$35,437.22,—and that said first party shall convey to said second party the real estate which has been foreclosed by reason of its heretofore having been given as security for any of the above indebtedness, and bought in by said first party, also the lots in Tourist City heretofore deeded by the Tourist City Town Company to said Hanna, and that said second party shall give a trust deed thereupon, also upon the north half of the N. E. quarter and the E. half of the N. W. quarter of Sec. 13, Tp. 28 S., R. 67 west, &c., to secure the payment of said notes, for \$31,000, and that upon payment of the same the several collaterals and other notes payable to said first party, and held on account of above matters, shall be thereupon assigned, without recourse on said first party, to the said party of the second part, and delivered to him as his own property, the said real estate to be conveyed to said second party by deed of said first party of date January 19th, 1892, and by trust deed of said second party dated January 20th, 1892. The collaterals above mentioned being scheduled as follows, to wit: 1,197 shares of stock in the Walsenburg Electric Light Company; 50 shares of stock of the Pythian Temple Association; 155 shares of the stock of the Tourist City Town Company; 720 shares of stock in the Walsenburg Water Company; three notes of T. F. Martin, each dated February 9th, 1891; one for \$5,000, due in six months; one for \$5,000, due in one year; one for \$10,000, due in 18 months; said notes being secured by a trust deed to J. P. Heisler,

trustee, which is recorded in Book 16, at page 264, of the records of Huerfano county; said notes being also given as evidence of indebtedness, which indebtedness is also evidenced by four other notes, upon the principal of which there is a payment of \$1,000; said four other notes being also included in the property here scheduled, and being described as follows (each signed by T. F. Martin and S. W. Watkins): One dated March 21st, 1890, for \$2,000; one dated May 21st, 1890, for \$5,000; one dated May 31st, 1890, for \$2,000; one dated June 7th, 1890, for \$12,000,—with various endorsements and credits thereon. Also the following notes: The note of the Tourist City Town Company, dated December 1, 1897, for \$8,670.00, on which a credit of about \$4,000 given by reason of the sale of certain property to the holder of said notes during the summer of 1891; one note of Louis De Camp, dated April 16th, 1888, for \$600; one note of L. Z. Watkins, dated July 8th, 1887, for \$100; one note of Gonzalez, dated April 5th, 1888, for \$160; one note of James O. Taylor, dated Aug. 20th, 1887, for \$160. Also three notes signed by T. F. Martin, which are secured by trust deeds on certain lands in said Huerfano county and lots in said town of Walsenburg, two of said trust deeds having been foreclosed, which embraces all the said lands and lots, and upon said notes proper credits have been made; said notes being described as follows: One dated April 28, 1887, for \$10,000; one dated May 25th, 1890, for \$2,500; one dated February 26, 1886, for \$5,000; one interest note dated February 26, 1886, for \$300, with various credits thereon. Also upon the payment of said notes for \$31,000 herein first mentioned, and the interest thereon, by said second party to the first party, all the papers, records, documents, pertaining to said lands above referred to, or to the stocks, notes, and other property herein scheduled, shall also be delivered to said second party as his own property, to be dealt with as he may deem best. All the above subject to all the suits by said Martin against said property or the payment of any of said notes; the proceeds, if any, to go to the credit of said Watkins.

“Executed in duplicate.

“Denver, Colorado, January 20, 1892.

“The City National Bank of Denver,

“By Wm. Barth, President.

“Wm. Barth.

“John R. Hanna.

“S. W. Watkins.”

“On the same day the defendant executed to said bank two notes, one for \$15,000, and the other (being the one in suit) for \$16,000, which were both delivered to said bank; and said defendant paid in cash to said bank the sum of \$4,437.22. For the purpose of carrying out this contract, as a part of the same transaction, Barth and Hanna, representing the bank, made a deed to the defendant, dated January 19, 1892, reciting the consideration of \$36,000, and that they ‘have granted, bargained, sold, and conveyed, and by these presents do grant, bargain, sell, and convey, unto the said party of the second part, his heirs and assigns, forever, all the following described lots and parcels of land,’ covering all the property, the title to which Barth or Hanna had acquired by the above-mentioned foreclosure, including the land hereinbefore specifically described on page 3 of these findings, ‘together with, all and singular, the hereditaments and appurtenances thereunto belonging or in any wise appertaining, and the reversion or reversions, remainder or remainders, rents, issues, and profits, thereof, and all the estate, right, title, interest, claim, and demand whatsoever of the said party of the first part, either in law or equity, of, in, and to the above-bargained premises, with the hereditaments and appurtenances, subject, however, to suits now pending against said property; the proceeds therefrom, if any, to be credited to said Watkins.’ As a part of the same transaction, the defendant executed a trust deed to the same premises, dated the 20th day of January, 1892, to secure the payment of the two notes mentioned above, and which deed contains a covenant that at the time of the making thereof he was well seised of the premises in fee simple, and that the same were free and clear of all liens and incumbrances whatever. The notes above mentioned were delivered to said bank, and the deed and trust deeds above mentioned were deposited in escrow with J. P. Heisler, who

on the 12th day of February, 1892, signed a memorandum of escrow, in the words and figures following:

“Memorandum.

“Memorandum of escrow in accordance with the contract accompanying this memorandum, which is dated January 20th, 1892, between William Barth, the City National Bank, and John R. Hanna, of the first part, and S. W. Watkins, of the second part, to wit, the deed of the property by first party to said second party has been executed, and the notes herein mentioned, to wit, for the sum of thirty-one thousand dollars, and has been executed by said second party, also the trust deed herein specified to secure the same; but it is understood that the said deed of conveyance made by said first parties, also the trust deed made by said second party, shall be held by John P. Heisler, and not delivered or recorded until such time as the litigation over the property in said deeds mentioned shall be determined, or until the parties executing said deeds may otherwise determine so to deliver or record the same; that said notes to the amount of \$31,000 shall, and are hereby delivered to the said party as of full force, and the respective copies of the agreement mentioned and hereto annexed, with a copy of this memorandum, is delivered to the respective parties as evidence of what has been entered into by them and is to be carried out. Also the notes are delivered and said sum of \$4,437.22 has been heretofore paid by said second party to said first party.

“Denver, Colorado, February 12, 1892.

“Executed in triplicate. Agreed to by all parties.

“J. P. Heisler, Atty.”

“The papers so deposited in escrow are still in the possession of Mr. Heisler. The litigation referred to in said escrow receipt was a suit brought by the mortgagor, Martin, against Barth, respecting the title under the foreclosure, and was finally determined in favor of said Barth on or about February 26, 1894. The value of the premises herein before specifically described appears from the evidence to have been \$25,000.

“Fifth. After the making of the said agreement of January 20, 1892, said William Barth, being the holder and owner as aforesaid of the note of Martin for \$5,000, and of the first mortgage or trust deed upon the premises described as aforesaid, securing said note, some time in the month of March, 1892, instituted proceedings to foreclose said first mortgage or trust deed by advertisement, and caused notice to be given of the sale thereof on April 11, 1892, the said Heisler acting as attorney for the said Barth therein; and thereupon the said Heisler attended at the time and place so appointed for said sale, the said defendant being present with him. Bids were made thereupon by said Heisler in behalf of Barth and the bank, and by a representative of one W. N. Coler, who was interested in the Walsenburg Waterworks, the reservoir connected with which was situated on said land. The sale was made by the sheriff of Huerfano county as successor in trust under the trust deed, and at the sale Heisler, in the name of Barth, as owner of the note, demanded that the sale be stopped, and tendered the note which was secured by the trust deed, with the memorandum attached thereto, signed by Heisler in the name of Barth, stating that the note had been fully paid. The sheriff refused to stop the sale, and the bidding proceeded; the two highest bids being made in behalf of Barth and the bank, and the next highest in the name of Coler; the bids being slightly in excess of \$15,000. Heisler demanded a deed of the property from the sheriff, and tendered in payment for the same the note secured by the trust deed, and the other notes secured by subsequent trust deeds on the property; but the sheriff refused to make a deed unless the whole amount bid was paid in cash, which Heisler declined to do, and the sheriff thereupon made a deed to said Coler, and offered to pay Heisler the sum of about \$6,000, the amount due on the note secured by the trust deed under which the sale was made; refusing, however, to pay the surplus over and above said sum to said Heisler or the representative of said bank. Heisler, on behalf of the bank, refused to accept the \$6,000. Thereupon the bank brought suit to set aside this sale; said Barth being plaintiff therein, and Coler and the sheriff being made defendants. The litigation finally resulted in

a decision against the plaintiffs, and affirming the said sale, whereby the title to the property was lost by the said bank and its representatives. Subsequently the bank demanded payment of the \$6,000 supposed to be in the hands of the sheriff who made the sale, but was unable to collect the same or any part thereof. The defendant was cognizant of all the proceedings aforesaid, but it does not satisfactorily appear from the proofs that he either directed or requested the bringing of such foreclosure. He was present at the sale by invitation of the attorney, but gave no directions in respect thereto. In the litigation referred to, to set aside the sale thereupon, the defendant participated both as a witness for the plaintiff, and by the employment of counsel to assist therein the counsel on the part of the bank, but not otherwise. Through such proceedings the title to the property in question was lost to the bank, and it became unable to convey the title thereof to the defendant in accordance with the agreement before mentioned, and the \$6,000, being the amount of the first mortgage note and interest, was also lost as aforesaid. And I find nothing in the conduct of the defendant in respect thereto to charge him with responsibility for the loss so incurred.

"Sixth. On January 29, 1896, before the final determination of the suit aforementioned to set aside the said sale by the sheriff, the defendant having paid the note in suit, except the sum of \$6,000 reserved thereupon, the plaintiff bank gave to the defendant a receipt thereupon as follows, to wit:

"\$10,800.

Denver, Colorado, January 29th, 1896.

"Received of S. W. Watkins the sum of ten thousand eight hundred (\$10,800) dollars, to be applied upon and as part payment of a certain promissory note dated January 20th, 1892, payable to the order of William Barth, executed by S. W. Watkins, due four years from the date thereof, which said payment appears as an indorsement on said note of this date; the balance due on said note, amounting to six thousand (\$6,000) dollars, to be carried without interest until the final determination of the suit of William Barth vs. W. N. Coler and Walter A. O'Malley, now pending in the supreme court of the state of Colorado.

"Executed in duplicate.

"The American National Bank of Denver,
"By John R. Hanna, Prest."

"And the suit referred to was finally determined by the aforementioned adverse decision of the supreme court of Colorado on June 24, 1897, and the consideration failed, at the least, for said unpaid balance of the note in suit.

"And as conclusions of law thereupon the court finds that the defendant is entitled to judgment dismissing the action, with costs in favor of the defendant. Let judgment be entered accordingly.

"[Signed]

Wm. H. Seaman, Judge."

The plaintiff in error (plaintiff below) filed its exceptions to such findings as follows:

"(1) The said plaintiff excepts to the refusal of the court to make the findings, and each of them, requested by the plaintiff.

"(2) The plaintiff excepts to that portion of the third finding of fact which reads as follows: 'And then obtained and now holds the said note subject to any defense existing in favor of said defendant affecting the consideration thereof. The said plaintiff did not acquire the said note as a bona fide holder for value, without notice of the equities subsisting between the parties thereto.' For the reason that the same is a conclusion of law, and is not supported by the evidence given on the trial of said cause.

"(3) The plaintiff excepts to that part of the fifth finding of fact reading as follows: 'And I find nothing in the conduct of the defendant in respect thereto to charge him with responsibility for the loss so incurred.' For the reason that the same is a conclusion of law, and is not supported by the evidence on the trial of this cause.

"(4) The plaintiff excepts to the conclusion of the court that the defendant is entitled to judgment, for the reason that the same is not supported by the findings of fact, and is contrary to the evidence introduced on the trial of said cause, and the law applicable thereto."

Thereupon judgment was entered in favor of the defendant in error, and is brought here for review.

The judge of the court below filed an opinion in the cause as follows:

"The suit is for recovery of the principal sum of \$6,000, and interest thereon remaining unpaid, upon a note for \$16,000 made by the defendant January 20, 1892, payable to the order of William Barth, who was president of the City National Bank of Denver, and received the note for the use and benefit of the bank. The plaintiff became the owner as successor to the assets and liabilities of the former bank, and holds the note subject to any defense existing in favor of the defendant, affecting the consideration. The answer sets up as a defense failure on the part of the payee to convey certain real estate in accordance with a contract of even date with the note; such real estate being then owned by the payee, and conveyance thereof by 'a good, sufficient, clear, and perfect title' being alleged as the consideration of the note.

"The testimony establishes, in substance, the following transactions as constituting the consideration of this note, together with another of like date for \$15,000: Prior to March, 1891, one T. F. Martin was indebted to the City National Bank on sundry notes, amounting to about \$20,000, upon which the defendant was an accommodation indorser; and the bank held as further security a mortgage given by Martin upon real estate holdings; which security was subordinate, however, to prior mortgages, being the fourth mortgage upon some of the property. When the defendant became indorser he was contemplating the purchase of an interest in the Martin properties, but later became dissatisfied with the state of affairs, and then urged upon the bank the purchase of the prior mortgages and collaterals outstanding against Martin, which were in the hands of Thurlow, Hutton & Williams, assuring the bank of the safety of such further investment, promising to advance a portion from means in his hands, for which he was to take the title to certain parcels of the real estate; and undoubtedly it was his intention to thus obtain an arrangement for securing himself as indorser. Thereupon Mr. Barth and Mr. Hanna, on behalf of the bank, purchased the prior mortgages and collaterals so held against Martin, bidding in the properties at foreclosure sales as previously advertised—that of the collaterals held on March 29, 1891, and of the premises under the second and third mortgages held on March 30, 1891; taking assignment of the first mortgage, which is the subject of this controversy. Of the investment thus called for, \$6,000 was furnished by the defendant, and was, by written agreement on the part of the bank, applied for the purchase by the defendant of a specific portion of the mortgaged property, not in controversy here; and the new investment of the bank was about \$11,500. Soon after the foreclosure sales of March 30th, two suits were commenced by Martin against Barth (the nominal bidder) to set them aside. At this stage of the transaction, and up to January 20, 1892, it was clear that the legal ownership of all these purchases from and through Thurlow, Hutton & Williams was vested in the bank, through its representatives; and, excepting as to the specific portion above mentioned, no express agreement appears between the bank and the defendant for the latter to have ownership of the property upon any terms. Since the hearing I have re-examined all the depositions in evidence, and the recitals of negotiations and conversations on the part of and with the defendant which led up to the purchase contain no stipulation or provision on one side or the other for his assumption of the purchase, aside from the single portion mentioned; and the fact of such express agreement in that instance would have called for a showing of strong equitable consideration before any parol understanding could have become admissible even for the protection of the defendant as indorser. On the other hand, the defendant alone testifies that there was a parol arrangement that he should attend to the disposition of the property to make the amount (1) of the investment in this purchase, and (2) the indebtedness for which he was held as surety, and that he expected further compensation or share of any surplus arising, though he claims there was no express agreement to that effect. It is true that this testimony was received at the hearing by way of reply to the rebutting case on the part of the plaintiff, and after the submission of the depositions on that behalf, and should be considered with due allowance

for such state of the proofs, with the witnesses for the plaintiff not present. But I find nothing in these statements by the defendant which is inconsistent with the facts stated on the other side; and it is clear that mere inferences, as stated by the witnesses for the plaintiff, that they acted for the benefit of the defendant throughout, cannot have effect beyond the facts related by them.

"I am satisfied, therefore, and so find from the undisputed testimony, that the bank, through its representatives, owned the securities and property, so far as the same is in controversy, up to the making of the contract of January 20, 1892, with no definite promise to or with the defendant for their purchase or acquisition by the latter, and the arrangement of that date was made and intended as an adjustment of the relations and interests of the parties, respectively, and that thereupon the purchase of the entire venture, as it then stood in the hands of the bank, was assumed by the defendant, in addition to his obligation as surety, all consummated in that contract, subject only to the conditions therein stated. The pre-existing arrangements and relations between the parties are admissible for the purpose of understanding the attitude in which they dealt, and to explain provisions not otherwise clear, but not to vary any of the terms.

"The contract entered into January 20, 1892, wherein Barth, the bank, and Hanna are first parties, and Watkins is the second party, recites the indebtedness to the first parties of Martin and Watkins, amounting to \$21,000, only partially secured by subordinate mortgages; the purchase by the first parties of the prior mortgages and collaterals held by Thurlow, Hutton & Williams against Martin for \$17,500, of which part is advanced by Watkins, so that there is due to the first party the sum of \$35,437.22 in the aggregate; and the foreclosure and sale of certain of the collaterals and mortgaged premises so purchased, which were 'bought in by the first party,'—and then provides that the second party shall execute notes for \$31,000, and pay in cash \$4,437.22, and for the conveyance thereupon by the first party to him of the property described. The second party is to make a trust deed to secure payment of his notes. Upon payment of the notes, all the collaterals described, including the notes of Martin, are to be transferred to the second party 'without recourse,' and the first mortgage upon the lands in question and notes therewith are enumerated to be thus transferred. It concludes as follows: 'All the above subject to all suits by said Martin against said property, or the payment of any of said notes; the proceeds, if any, to go to the credit of said Watkins.' On February 12, 1892, to carry out this contract, deeds of conveyance of the real estate on the part of the first parties, and the trust deed on the part of the second party, were executed, and both deposited in escrow with Mr. Heisler, an attorney, to be held by him 'until such time as the litigation over the property in said deeds mentioned shall be determined,' or the parties should otherwise direct. But the notes for \$31,000 were delivered to the first parties 'as of full force,' and the cash provided for was paid over by the second party. In a letter from Mr. Hanna to the defendant, which is practically simultaneous with the contract, and refers to its transmission, it is remarked, 'We, of course, will defend the suits progressing.'

"This contract, on its face, is manifestly one of bargain and sale of the property and securities enumerated, and I am of opinion that no other interpretation of the final arrangement is admissible, in the light of all the testimony offered of pre-existing facts; that all were to be transferred and accepted in the status and subject to all conditions of rights and title as then existing, of which the defendant was at least equally advised, with no covenants of title otherwise, express or implied. So construed, the vendor was bound to preserve existing rights to the extent of its means and power, and, when the conditions were fulfilled in conformity with the contract, was bound to perform with such rights unimpaired by any default or conduct on its part, unless excused by a sufficient release, or by acts or requirements on the part of the vendee which create an estoppel. Beyond this obligation, the doctrine of *Van Rensselaer v. Kearney*, 11 How. 297, 322, 13 L. Ed. 703, and other like cases cited on behalf of the defendant, is not deemed applicable; nor is the vendor in the position of a mere holder of collaterals, or of a stakeholder, as counsel for the plaintiff contends, and the rule of ordinary care and dili-

gence which obtains in such cases is not the test of liability for nonperformance.

"With the contract relation thus held, the final question remains, which party in interest must be held responsible for and must bear the loss incurred through the subsequent proceedings in the name of the vendor for a foreclosure sale under the prior mortgage? This singular transaction resulted not only in the destruction of the vendor's previous title in fee to the valuable real estate involved in such sale, and included in the executory contract to the defendant, but in the loss as well, through unfortunate circumstances, of the sum secured by the mortgage,—\$6,000 and over. The foreclosure sale occurred in April, 1892, under a proceeding by advertisement instituted by direction of Barth, one of the vendors and nominal assignee of the mortgage, and conducted by J. P. Heisler as attorney for the bank and its representatives. At the sale, however, the sheriff, who was appointed trustee for the purpose, acted in disobedience of the express directions of Mr. Heisler that he should not open or proceed with the sale under the notice, and later refused to recognize the bids made on behalf of the mortgagee, unless paid in cash, and finally deeded the property to a third party, whose bid was asserted to be the next best. Mr. Heisler had exclusive charge on the part of the bank, although the defendant and a local attorney were present and were fully informed on the day of the sale of his action throughout, namely, of his protests against and procedure with the sale, of his making bids over those offered, and other efforts to prevent adverse sale (not material for the present controversy), and of his eventual refusal to accept from the sheriff the amount tendered to cover the foreclosed mortgage, because he intended to repudiate the sale, and not to recognize it as valid for any purpose. Subsequently the bank instituted a suit to set aside the sale and conveyance, of which it is sufficient to remark that the defendant concurred in such action, employed counsel to aid in its prosecution, with the final result of a decision by the supreme court of the state upholding the sale; thus defeating the title which had become vested in the bank under the previous foreclosures, and depriving the defendant of a portion of the property included in his contract, which exceeded in value the unpaid balance of his notes. Furthermore, the mortgage security involved in that sale was lost through the merger; and the proceeds of the sale, of which tender had been refused, being left in the hands of the sheriff pending the litigation, were likewise lost through the subsequent insolvency and death of the sheriff, with no liability existing upon his official bond for a default of such nature. It should be observed, in passing, that the suits by Martin against the vendors, mentioned in the contract and in the terms of the escrow, were dismissed upon a trial, and were out of the way of performance long before the conclusion of the litigation over the sale in question, but were pending at the date of such sale.

"The testimony discloses no substantial reason for the proceeding to foreclose the first mortgage, which gave rise to the serious complication of the title and eventual loss. So far as appears, no benefit could be derived from it, even if carried out unopposed. But for the purposes of this case the only inquiry is, who was the real mover and actor in the proceeding from which the loss ensued? No question is presented of negligence by either party in the subsequent contest. Each was represented by able counsel, working in harmony, and confident of saving the property from the ill-advised foreclosure sale. Whichever of the contracting parties originated and carried on the unfortunate foreclosure proceedings must bear the resultant loss, represented, so far as concerns this case, by the unpaid balance of the purchase-money note in suit. The question is one of fact, and its solution is saved from difficulty by reason of the absence of direct testimony in point on the part of the plaintiff, thus presenting no substantial conflict in the evidence. The mere fact that the foreclosure was instituted in the name of the vendor party is not the test, for it could not have proceeded otherwise; but the fact that Mr. Heisler, as attorney for the bank, acted solely upon the instructions from that source, without understanding that he was to act under directions of the defendant, as his testimony clearly shows, at least casts the burden of proof upon the plaintiff, if it does not so rest on the prima facie case of the defendant.

"An examination of the testimony of Mr. Barth and Mr. Hanna furnishes no support for the assertion that the defendant directed this move. No written or verbal communication on the part of the defendant to so proceed is specified, nor is any explanation given by either for it, aside from the mere general statements of the inferences of these interested witnesses,—that it was 'for his benefit,' and in some instances stating it in the same general way as 'at his request,' but with no specification of even the substance of his language. In the connection stated, the answers are not probative, and are clearly insufficient to charge the defendant with the responsibility, in the face of his direct testimony that he neither requested nor suggested such course, and that it was entirely the plan of Mr. Barth, as a countermove for the Martin suits, mentioned to the defendant in a general way, only, and not as a foreclosure proceeding. The fact of the defendant's presence at the foreclosure sale, and of Mr. Heisler's conferences with him and with the local attorney, and the further fact of his taking part in the suits to set aside the sale, by the employment of counsel, and otherwise manifesting his interest, cannot serve to charge the responsibility against him. Nor was the duty cast upon the defendant to decide, after the fact of sale, whether or not the suit should be abandoned, and the proceeds accepted in lieu of the real estate,—certainly not upon the mere suggestion to that effect, stated by the witness Freeman in his testimony. I am of opinion, therefore, that the defendant is entitled to findings in his favor, and they may be prepared accordingly."

A voluminous bill of exceptions was filed, preserving many exceptions to supposed errors of the court in the admission and rejection of evidence, which need not be specifically stated, and are sufficiently referred to in the opinion of the court.

T. J. O'Donnell and Edward W. Frost, for plaintiff in error.
George H. Noyes, for defendant in error.

Before JENKINS and GROSSCUP, Circuit Judges, and BUNN, District Judge.

JENKINS, Circuit Judge (after stating the facts as above). The special finding of the statute should speak the ultimate facts on which the law must determine the rights of the parties, and should not contain a statement of the evidence from which those facts are determined. It is immaterial whether the finding rests on oral testimony or upon written evidence, or in part upon one and in part upon the other. The finding of fact is conclusive upon the appellate court, which may not search the evidence to ascertain if the finding be warranted. We may only inquire whether error intervened in the admission or exclusion of testimony, which should work a reversal of the judgment, and whether the facts found support the judgment rendered. The courts have often spoken to this subject, and the question is no longer an open one. *Wilson v. Trust Co.*, 183 U. S. 121, 22 Sup. Ct. 55, 46 L. Ed. 113; *Distilling & Cattle Co. v. Gottschalk Co.*, 13 C. C. A. 618, 66 Fed. 609; *Insurance Co. v. International Trust Co.*, 17 C. C. A. 616, 71 Fed. 88; *Minchen v. Hart*, 18 C. C. A. 570, 72 Fed. 294; *Jenks' Adm'r v. Stapp*, 9 U. S. App. 34, 3 C. C. A. 244, 52 Fed. 641; *Corliss v. Pulaski Co.* (C. C. A.) 116 Fed. 289.

We pass the first exception without comment, because the record fails to disclose that the defendant in error presented any findings, or requested the court to adopt them, or that there was any refusal upon the part of the court with respect thereto. We say this without implying that the practice suggested is permissible, or that error may be assigned upon refusal of the court to find as requested.

The second exception is to that portion of the third finding of fact which declares that the note was obtained by the plaintiff in error subject to any defense affecting the consideration, and that the plaintiff in error was not a bona fide holder for value, without notice. The objection urged is that this finding is a conclusion of law, and is not supported by the evidence. We are not warranted in looking into the evidence to ascertain if the finding be supported by it. The finding is not that of a conclusion of law. It is a finding of fact, dependent upon the circumstances under which the note was transferred.

The third exception is to that part of the fifth finding of fact to the effect that the court found nothing in the conduct of the defendant touching the foreclosure of the first mortgage by Barth and the bank, and the ensuing litigation with Coler, to charge him with responsibility for the loss thereby incurred. That is also a conclusion of fact, rather than of law,—a negative statement which finds as a fact that the defendant in error did not request or sanction the litigation in question. We may not review the evidence to ascertain whether that finding be warranted. It may, perhaps, be said of the findings that they embody evidence and inferences of fact in addition to the ultimate facts upon which judgment must proceed; but that gives the appellate court no right of review.

The fourth exception goes to the conclusion of law that the defendant below was entitled to judgment of dismissal of the complaint, and this proceeds upon the theory that the facts found do not support the judgment. The issue presented, aside from the question whether the plaintiff in error held the note subject to equities, is whether the consideration of the note had failed. The court, by its fourth finding, stated the facts found with respect to the execution of the note and its consideration. The court has not found as an ultimate fact that the consideration of the note was the agreement to convey the title to the land, but it does find that such was the purport of the agreement under which the note was executed. The finding seems to be that of the court's conclusion of the legal effect of the agreement of the parties. We have therefore sought to ascertain if the court below correctly held with respect to the legal effect of the agreement of January 20, 1892. The question is one not without difficulty, and has engaged our careful scrutiny. We have reached the conclusion that the court below was correct in its finding. The reasoning of the opinion of the court below, which is incorporated in the statement of facts, seems to us well founded, particularly in view of the fact found by the court that Barth owned the real estate and prior mortgages thereon, without promise or obligation on his part or on the part of the bank to sell or otherwise dispose thereof to the defendant. That being the condition of affairs at the time of the execution of the agreement of January 20, 1892, we think the court below was right in holding that the agreement was that of bargain and sale of the property and the securities mentioned, and that the subsequent failure of title through the conduct of Barth and the bank should not be visited upon the defendant in error.

It is also urged that partial failure of consideration is not a good defense at law, the amount being unliquidated. This is the English

rule, formerly followed in the United States. *Wentworth v. Goodwin*, 21 Me. 150; *Morrison v. Jewell*, 34 Me. 146; *Hogden v. Golder*, 75 Me. 293; *Drew v. Towle*, 27 N. H. 412, 59 Am. Dec. 380; *Riddle v. Gage*, 37 N. H. 519, 75 Am. Dec. 151; *Richardson v. Sanborn*, 33 Vt. 75; *Pulsifer v. Hotchkiss*, 12 Conn. 234; *Allen v. Bank*, 20 N. J. Law, 620. But the rule is now otherwise, and the cases referred to in Connecticut and New Jersey have been in express terms overruled by the courts of those states. *Avery v. Brown*, 31 Conn. 398; *Bouker v. Randles*, 31 N. J. Law, 335; *Wyckoff v. Runyon*, 33 N. J. Law, 107.

We have scrutinized the many assignments of error relating to the admission and rejection of evidence at the trial. Many of them are merely formal; some going to the order of proof, some to the striking out of testimony which was mere conclusion of witnesses. We find none of them of sufficient moment to consider at length, and none of them availing to a reversal of the judgment. If any of the rulings may be considered as technical and erroneous, it is clear that the errors charged, if such there were, could not have prejudiced and did not prejudice, and ought not to work a reversal. *Lancaster v. Collins*, 115 U. S. 222, 6 Sup. Ct. 33, 29 L. Ed. 373; *Holmes v. Goldsmith*, 147 U. S. 150, 13 Sup. Ct. 288, 37 L. Ed. 118; *Miller v. Railway Co.*, 5 C. C. A. 134, 55 Fed. 366.

The judgment is affirmed.

581 DIAMONDS (VAN ANTWERPEN et al., Claimants) v. UNITED STATES.

(Circuit Court of Appeals, Sixth Circuit. January 6, 1903.)

No. 1,083.

1. CUSTOMS LAWS—FORFEITURE OF SMUGGLED GOODS—RIGHT OF VENDOR TO RECLAIM GOODS OBTAINED BY FRAUD.

A seller of goods, which were delivered to the purchaser, although having the right, as against the purchaser, to rescind the sale and recover the goods, because they were obtained by means of fraudulent representations and with the intention on the part of the purchaser not to pay for the same, cannot assert such right against the right of the United States to forfeit the goods, where they were seized when the purchaser, while thus clothed with ownership and possession, was attempting to smuggle them into the country in violation of its customs laws.

In Error to the District Court of the United States for the Eastern District of Michigan.

On the 6th of July, 1899, the district attorney of the United States for the Eastern district of Michigan, filed an information seeking to condemn 581 diamonds, alleged to have been forfeited. The record discloses that these goods were seized when about to be unlawfully imported and smuggled into the United States on June 28, 1899, at Detroit, Mich., by one Louis Bush. Proceedings were duly had resulting in a judgment of forfeiture, which, so far as Bush is concerned, is not now contested. On the 22d of January, 1900, the firm of Van Antwerpen & Van Den Bosch were allowed to intervene and plead in the case. These parties claimed the diamonds as against the right

of the government to forfeit the same, and after further proceedings (not necessary to set out) were allowed to file an amended answer in the case setting up their claim, which is as follows:

The amended answer of Charles B. Van Antwerpen and Jean C. Van Den Bosch, the respondents to the above action, and intervening therein, now and at all times hereinafter saving to themselves any and all manner of benefit and exception that can or may be had or taken to the errors, uncertainties, and imperfections in the libel of information filed herein, for answer thereto, or to so much thereof as these defendants are advised is material and necessary to make answer to, answering say:

First. That they are now, and were at all times hereinafter set forth, co-partners doing business in the city of Antwerp, kingdom of Belgium, under the firm name and style of Van Antwerpen & Van Den Bosch, dealing in diamonds, cut and uncut.

Second. That on or about the 6th day of June, in the year 1899, one Max Hurvich called upon respondents and stated that he desired to purchase diamonds from respondents.

Third. Said Hurvich represented to respondents that he had been theretofore engaged in the clothing business in the city of New York, United States of America, but had given up said business and was about to engage in the purchase and sale of diamonds in said city of New York, and would make his office and place of business at the premises number nine (9) Maiden Lane, in said city; that he had considerable means, and was worth over and above all liabilities upwards of the sum of forty thousand dollars (\$40,000), and desired to purchase from respondents diamonds on credit, and was making these representations as to his financial standing for the purpose of inducing respondents to give him a line of credit.

Fourth. That for the purpose of inducing respondents to give him a line of credit he did then and there further represent to respondents that he had theretofore had business dealings with certain persons residing in the city of New York, and that all his dealings with such persons has been satisfactory to such persons; that so far as respondents can remember the persons so referred to by said Hurvich are Roseman, Maiden Lane, New York.

Fifth. As a further inducement why respondents should sell diamonds to said Hurvich, he represented to respondents that, in order to prepare to conduct and carry on the business in which he was about to engage, he needed large sums of cash, and therefore was not able to pay cash to respondents for all the goods which he at that time desired to purchase.

Sixth. Said Hurvich further represented to respondents that within six or seven months he would realize cash from some of his other property, and would be in a position to pay whatever there might be due on the unpaid purchase price of whatever diamonds he might purchase of respondents, and that his property was amply sufficient to enable him to raise all the funds that he might need for that purpose.

Seventh. Respondents, further answering, show that they believed each and every of said representations so made by said Hurvich to be true, and in reliance thereon did, on said 6th day of June, 1899, sell and deliver to said Hurvich, at said city of Antwerp, a large number of diamonds, to wit, upwards of five hundred and twenty-five (525) diamonds of various weights and measurements, to the value of four thousand two hundred and seventy-seven (4,277) pounds, twelve (12) shillings, and six (6) pence in English money, and in reliance upon the truth of said statements so made as aforesaid by said Hurvich did give said Hurvich credit on the purchase price of said diamonds to the extent of two thousand two hundred and seventy-seven (2,277) pounds, twelve (12) shillings, and six (6) pence in English money, and did agree to allow said Hurvich until the 18th day of December, 1899, to pay said last-mentioned sum, which said last-mentioned sum it was agreed said Hurvich should pay at London, England.

Eighth. Respondents, further answering, show that since the aforesaid purchase from respondents said Hurvich has admitted that at the time of said purchase he had formed the purpose of obtaining said diamonds without paying therefor the said sum of two thousand two hundred and seventy-

seven (2,277) pounds, twelve (12) shillings, and six (6) pence so remaining unpaid as aforesaid on the purchase price; and, further, that prior to the purchase of said diamonds, and at the time of the purchase thereof, he had formed the purpose of obtaining said diamonds without paying the full purchase price thereof, and with the intention and purpose of raising money on them by pledging or selling them to pawnbrokers or other persons who might be found willing to lend money thereon, or to purchase them at prices below their market value.

Ninth. Respondents, further answering, show that in furtherance of said fraudulent purpose and design said Hurvich did not pay said sum of two thousand two hundred and seventy-seven (2,277) pounds, twelve (12) shillings, and six (6) pence when the same became due as aforesaid, at the city of London, England, on the said 18th day of December, 1899.

Tenth. Respondents, further answering, say that they are advised and believe, and upon such information and belief they charge the fact to be, that said Hurvich, with said diamonds in his possession, proceeded directly from said city of Antwerp to the dominion of Canada, and there met one Louis Bush, who, your respondents charge, was a confederate of said Hurvich, and did then and there turn over and deliver to said Bush the said diamonds so as aforesaid obtained from respondents.

Eleventh. Respondents, further answering, say that since their former answer herein said Hurvich has admitted that the said diamonds now in the possession of the said court are a portion of those so obtained as aforesaid from respondents.

Twelfth. Respondents, further answering, say that, had they known at the time said representations so made as aforesaid by said Hurvich to them to be untrue, they (said respondents) would not have surrendered and delivered up said diamonds to said Hurvich.

Thirteenth. Respondents, further answering, say that the said representations made by the said Hurvich to said respondents, and upon which said respondents relied in making the sale and delivery of said diamonds, were each and every of them false and untrue, and respondents show that said Hurvich was not on said 6th day of June, 1899, worth over and above all liabilities upwards of the sum of forty thousand dollars (\$40,000); and respondents further show that the dealings of said Hurvich with the persons mentioned in the fourth paragraph of this answer had not been satisfactory to said persons; and respondents, further answering, deny that said Hurvich on said 6th day of June, 1899, had any property whatsoever from which he could realize cash within six or seven months after said last-mentioned date, as he told respondents he would be able to do; and respondents deny that he had any property sufficient to enable him to raise all the funds that he might need for the purpose of paying these respondents.

Fourteenth. Respondents, further answering, show that said representations so made as aforesaid, by said Hurvich were false and untrue, and made for the purpose of inducing these respondents to part with said diamonds to said Hurvich without receiving full payment therefor, and in furtherance of a fraudulent scheme and purpose theretofore entered into by and between said Hurvich, one Louis Bush, and one Louis Rosenberg of said city of New York, wherein and whereby it was agreed that said Hurvich should obtain said diamonds of your respondents by fraud and deceit, and when obtained he, with said Bush and said Rosenberg, should dispose of the same and the proceeds therefrom share with said Bush and Rosenberg.

Fifteenth. Respondents, further answering, say that they have been told that said Louis Rosenberg, named in the answer filed by said Louis Bush herein, is a pawnbroker in the city of New York, and they deny that said Louis Rosenberg is the owner of said diamonds, or any or either of them.

Sixteenth. Respondents, further answering, show that said five hundred and eighty-one (581) diamonds seized by the officers of the United States government, and which are the diamonds now being proceeded against in this honorable court, are some of the same diamonds so fraudulently obtained by them by said Hurvich.

Seventeenth. Respondents, further answering, show that they are prepared to repay, and do now tender, to this honorable court, or to such person as

this court may determine to be entitled thereto, the said sum of two thousand (2,000) pounds, so paid as aforesaid by said Hurvich to respondents as a part of the purchase price of said diamonds.

Wherefore respondents pray that upon the final hearing herein this honorable court may order and decree that the diamonds seized herein be, and are, the rightful property of the respondents, and that the same be restored to them free of duty; and they pray for such other and further relief as this honorable court may deem just and proper under the circumstances.

The district attorney filed exceptions raising the question of the sufficiency of this answer to entitle the claimants to the relief prayed for. These exceptions were sustained by the district judge, who found that Van Antwerpen & Van Den Bosch were not entitled to the goods, but the same were adjudged forfeited to the United States. From this order and judgment a writ of error is taken to this court.

Bowen, Douglas & Whiting (Peter Zucker, of counsel), for plaintiffs in error.

Wm. D. Gordon, U. S. Atty., and James V. D. Willcox, Asst. U. S. Atty.

Before LURTON, DAY, and SEVERENS, Circuit Judges.

DAY, Circuit Judge, after making the foregoing statement, delivered the opinion of the court.

As between the government and Bush there can be no question that the right to forfeit the goods seized has been fully and clearly made out. Bush was caught with the diamonds concealed in his shoes. He denied all knowledge of how he came to be thus possessed of the gems when entering the port of Detroit. On his way to the prison he practically confessed his offense in saying to the officer: "Now, if you have got all that you are looking for, let me go." The only question of importance in the case is as to the sufficiency of the amended answer of Van Antwerpen & Van Den Bosch to require the diamonds to be returned to them, instead of forfeited to the government. If the diamonds were imported in violation of the statute, it is established law that the forfeiture dates from the time of the commission of the wrongful act and binds the goods from that date. Henderson's Distilled Spirits, 14 Wall. 44, 20 L. Ed. 815. For the purposes of this inquiry we may regard the amended answer of the claimants as true. Thus treated, it makes allegations sufficient to establish the fraudulent character of the purchase of the diamonds by Hurvich. It is distinctly averred that not only did Hurvich make false statements to induce the sale as to his financial responsibility, but it is alleged that the goods were purchased in furtherance of a fraudulent scheme not to pay for them. In such case there can be no doubt of the right of the vendor to rescind the sale and recover the goods in the hands of the vendee, or from others than innocent purchasers for value. The rule is thus tersely stated by Mr. Justice Davis, in *Donaldson v. Farwell*, 93 U. S. 631, 23 L. Ed. 993:

"The doctrine is now established by a preponderance of authority that a party not intending to pay, who, as in this instance, induces the owner to sell him goods on credit by fraudulently concealing his insolvency and his intent not to pay for them, is guilty of a fraud which entitles the vendor, if no innocent third party has acquired an interest in them, to disaffirm the contract

and recover the goods. *Byrd v. Hall*, *41 N. Y. 647; *Johnson v. Moneff*, Id. 655; *Noble v. Adams*, 7 Taunt. 59; *Kilby v. Wilson, Ryan & M.* 178; *Bristol v. Wilsmore*, 1 Barn. & C. 514; *Stewart v. Emerson*, 52 N. H. 301; *Benj. Sales*, § 440, note of the American editor, and cases there cited."

In *Morrow Shoe Mfg. Co. v. New England Shoe Co.*, 6 C. C. A. 515, 57 Fed. 693, 24 L. R. A. 417, it is said:

"The seller, on discovering the fraud, may affirm the sale and sue for the price, or he may disaffirm it and reclaim the goods, or he may proceed criminally."

Notwithstanding the fraud, if there is an intention to part with the title, as well as the possession, the title passes subject to the right of the vendor to rescind the sale and reclaim the property. *Benj. Sales*, § 517. It is the intent of the law, so far as the forfeiture feature is concerned, to work that result only in cases where the owner, or some of those named in the statute, in his interest, are guilty of the attempt to defraud the revenue. *Origet v. U. S.*, 125 U. S. 240, 8 Sup. Ct. 846, 31 L. Ed. 743; *U. S. v. 1150½ Pounds of Celluloid*, 27 C. C. A. 231, 82 Fed. 627. The contention in this case is that neither Hurvich nor Bush were the owners of the goods, and that the real ownership as against the government's claim was in the claimants. When the goods were delivered to Hurvich under the circumstances detailed in the amended answer, he became the owner of them. He had the unqualified right to the possession thereof. He might lawfully remove them. That he intended to import them into the United States was well known to the vendors; not, it is true, with authority of the sellers to smuggle them into the country, but the control and possession of the property was delivered up, leaving the vendors to the right to rescind if they chose and recover the property. But there was always the chance that before the vendor became acquainted with the facts, or after knowledge and before action was determined upon, the one who had the ownership and control of the property might change its status so as to render ineffectual the right to rescind. The authorities agree that this would be the result of a sale to an innocent purchaser. It might be incurred in favor of one who dealt in good faith on the strength of the apparent ownership and title.

The question made is: Can the vendor assert this right against the right of the United States to forfeit the goods, when the one thus clothed with title and possession has attempted to smuggle them into the country in violation of its revenue laws? The statute under which forfeiture is claimed by the government is as follows:

"That if any owner, importer, consignee, agent or other person shall make or attempt to make any entry of imported merchandise by means of any fraudulent or false invoice, affidavit, letter, paper, or by means of any false statement, written or verbal, or by means of any false or fraudulent practice or appliance whatsoever, or shall be guilty of any willful act or omission by means whereof the United States shall be deprived of the lawful duties, or any portion thereof, accruing upon the merchandise, or any portion thereof, embraced or referred to in such invoice, affidavit, letter, paper or statement, or affected by such act or omission, such merchandise, or the value thereof, to be recovered from the person making the entry, shall be forfeited, which forfeiture shall apply only to the whole of the merchandise, or the value thereof, in the case or package containing the particular article or articles of merchandise to which such fraud or false paper or statement relates. And

such person shall, upon conviction, be fined for each offense a sum not exceeding five thousand dollars, or be imprisoned for a time not exceeding two years, or both, in the discretion of the court." Act June 10, 1890, § 9, 1 Supp. Rev. St. p. 749 [U. S. Comp. St. 1901, p. 1895].

Statutes to prevent frauds upon the revenue are considered to be enacted for the public good, and therefore, although they impose penalties or forfeitures, are not to be construed like penal laws generally, but are to be fairly and reasonably construed, so as to carry out the legislative intent. *U. S. v. Stowell*, 133 U. S. 1, 10 Sup. Ct. 244, 33 L. Ed. 555. It will be observed that the wrongful act, in order to work the forfeiture, must be done by "the owner, importer, consignee, agent, or other person." It is the attempt of this class of persons to evade the revenue laws of the United States; that is, to deprive the owner of his property as a punishment for such unlawful practice. In *U. S. v. 1,150½ Pounds of Celluloid*, 27 C. C. A. 231, 240, 82 Fed. 627, this court held that the descriptive words following the term "owner," to wit, "importer, consignee, agent," all describe some person having a relation to the owner, and for whose conduct in respect to his goods he may be responsible. It was further held that "other person," as here designated, meant some one of the same general class as those described in the associated terms used in the statute. It is, then, primarily the "owner" who is to be reached and punished by the forfeiture. When these goods were attempted to be smuggled in by Bush, it is directly averred that he was acting in collusion with Hurvich. If the averments of the amended answer are true, the latter, the legal owner of the goods, was deep in this scheme to defraud the revenue.

The statute is plain and clear in visiting the penalty of forfeiture upon the owner and his importer, consignee, or agent. Are we at liberty to so modify the statute as to qualify this right by reading into it an exemption of property, which, though fraudulently imported by the owner, is in such situation as to title that, because of the fraud of the owner, another might have claimed the property and divested the title? We cannot perceive on what principle we may do this. When an act comes within the terms of the statute, working a forfeiture which may entail a hardship, it is nevertheless to be enforced, not repealed or modified, by the courts. The right of congress to pass suitable revenue laws is conceded. It is the business of the courts to enforce such as are constitutionally passed. "Congress possesses the power to levy taxes, duties, imports, and excises, and it is as clear that congress may enact penalties and forfeitures for the violation of such laws as it is that congress may levy the taxes or duties or pass laws for their collection, safe-keeping, and disbursement." *Henderson's Distilled Spirits*, 14 Wall. 44-59, 20 L. Ed. 815.

So frequent are attempted frauds upon revenue laws that the wisdom of congress cannot be doubted in making strict regulations, which shall preserve the revenue of the government and prevent undue privileges to those who seek to enter the markets against the honest importer with the unlawful advantage of free goods gained by fraudulent acts and practices. When the owner has forfeited the goods by the unlawful acts shown in this case and admitted in the answer, the

operation of the statute seems clear, and the only judicial function is to enforce the law. To permit secret claims of ownership to be asserted after forfeiture would be in plain violation of the written law.

We have been unable to find any reported case which goes the length asked by the plaintiffs in error here. Two of those relied upon were reviewed by this court in *U. S. v. 1,150½ Pounds of Celluloid*, supra. Of them Judge Lurton said:

"In *U. S. v. 208 Bags of Kainit* (D. C.) 37 Fed. 326, there was no doubt of the intent with which the trespasser had made the unlawful removal of the merchandise involved in that case. The forfeiture was defeated because the owner had not done or authorized these acts, and could, therefore, have had no guilty intent; and the case was decided against the government because it was necessary to show an actual intent on the part of the owner, or some person acting under his authority, or under whom he derived title. So, in the case of *The Cargo ex Lady Essex* (D. C.) 39 Fed. 765, there was no doubt of the intent of the master of the *Lady Essex*. But the owner of the merchandise had not attempted to smuggle the goods into the United States, nor authorized the acts of those who had made such an attempt, and therefore could have no intent to defraud; and the language of sections 12 and 16 of the act of June 22, 1874, was construed by Judge Brown to 'apply to the owner of the goods, or his authorized agent, and not to a mere trespasser.'"

In the Celluloid Case the claim was made that the act of June 10, 1890 [U. S. Comp. St. 1901, p. 1886], was broad enough to require the forfeiture of the goods, although the owner was wholly guiltless of any participation in the attempted fraud. In that case the celluloid was stored in Windsor. It was attempted to be smuggled into Detroit by an employé, who was acting without authority and for his own unlawful gain. It was held that this did not forfeit the goods as against the innocent owner. In all the cases cited the goods were not given over by the owner, but were taken wholly without authority and by acts which practically amount to theft or trespass. In holding against the claim of forfeiture the courts have construed the statute as not intending to take the property of the owner for the wrongful or criminal acts of others wholly unauthorized in the premises. In the present case, while there may have been the right to rescind this sale for fraud, it was the act of the owner in attempting to defraud the revenue which brings the case within the terms of the statute.

We find no error in the proceedings in the district court, and its judgment will be affirmed.

POWERS v. UNITED STATES.

(Circuit Court of Appeals, Sixth Circuit. January 6, 1903.)

No. 1,072.

1. PUBLIC LANDS—UNLAWFUL CUTTING OF TIMBER—ACTION BY UNITED STATES.

The United States may maintain an action to recover the value of timber cut from unsurveyed mineral lands to which its title has not been divested, notwithstanding the locating of mining claims thereon by third parties.

2. TRIAL TO COURT—SPECIAL FINDINGS OF FACT.

In an action at law in a circuit court, where a jury is waived by stipulation, pursuant to Rev. St. § 649 [U. S. Comp. St. 1901, p. 525], and special findings are made by the court, such findings must state the ultimate

facts, presenting questions of law only, and, where only probative facts are found, leaving ultimate facts necessary to support the judgment to be inferred, the judgment must be reversed, and a new trial ordered.

8. PUBLIC LANDS—UNLAWFUL CUTTING OF TIMBER—MEASURE OF DAMAGES.

One who cut and removed timber from public mineral lands, which he converted into lumber and sold for the purposes permitted by Act June 3, 1878 [U. S. Comp. St. 1901, p. 1528], is not liable, as a willful trespasser, for the added value of the timber due to his labor and expense, merely because of his failure to keep the record required by the rules prescribed by the general land office pursuant to such act, if he believed in good faith that he was a resident of the state in such sense as to be within the terms of the act, and where his failure to keep the record was due to his ignorance that it was required.

In Error to the Circuit Court of the United States for the Southern Division of the Western District of Michigan.

This is an action in trover, brought by the United States to recover the value of certain logs and lumber converted by the plaintiff in error from pine timber standing on mineral lands in South Dakota belonging to the United States, on which locations had been made by other parties. The first count in the declaration alleges the conversion of 668,000 feet of pine lumber, and the second count the conversion of the same number of feet of pine logs. The defendant pleaded the general issue. The parties stipulated to waive a trial by jury, and that the cause should be heard and determined by the judge. It was also stipulated that the title to the lands from which the timber was cut was then in the United States, and that they were unsurveyed mineral lands. Pursuant to a request of counsel for the defendant, the court made special findings of the facts and law, which were filed before the entry of the final judgment, to many of which findings the defendant excepted. Upon the findings so made and filed, judgment against the defendant was entered for \$7,241 as damages, and for costs, whereupon the defendant brought the case here on writ of error.

Kingsley & Wicks (Kingsley & Kleinhans, of counsel), for plaintiff in error.

George G. Covell, U. S. Dist. Atty., and Walter I. Lillie, Asst. U. S. Dist. Atty.

Before LURTON, DAY, and SEVERENS, Circuit Judges.

SEVERENS, Circuit Judge, having made the foregoing statement of the proceedings in the case, delivered the judgment of the court.

1. The plaintiff in error raises the question whether, the lands on which the timber stood, having been already located, and thereby segregated from the public domain, the United States can maintain this action. But as the location had not been ripened by purchase and payment, and the title of the United States had not yet been divested, we have no doubt the plaintiff was entitled to bring the suit.

2. The principal question in the controversy, aside from the question of damages, arises upon the defense made under the act of congress of June 3, 1878 [U. S. Comp. St. 1901, p. 1528], granting the privilege to certain persons and for certain purposes to cut standing timber in that locality. The act reads as follows:

"All citizens of the United States and other persons, bona fide residents of the state of Colorado or Nevada or either of the territories of New Mexico, Arizona, Utah, Wyoming, Dakota, Idaho or Montana, and all other mineral districts of the United States, shall be and are hereby authorized and permitted to fell and remove for building, agricultural, mining or other domestic

purposes, any timber or other trees, growing or being on the public lands, said lands being mineral and not subject to entry under existing laws of the United States, except for mineral entry, in either of said states, territories or districts of which such citizens or persons may be at the time bona fide residents, subject to such rules and regulations as the secretary of interior may prescribe for the protection of the timber and of the undergrowth growing upon said lands, and other purposes: provided, the provisions of this act shall not extend to railroad corporations.

"Sec. 2. That it shall be the duty of the register and the receiver in the local office in whose district any mineral land may be situated, to ascertain from time to time, whether any timber is being cut or used upon any such lands, except for the purposes authorized by this act, within their respective land districts, and if so, they shall immediately notify the commissioner of the general land office of that fact, and all necessary expenses incurred in making such proper examinations shall be paid and allowed said register and receiver, in making up their next quarterly account.

"Sec. 3. Any person or persons who shall violate the provisions of this act, or any rules and regulations in pursuance thereof, made by the secretary of the interior, shall be deemed guilty of a misdemeanor, and upon conviction shall be fined in any sum not exceeding five hundred dollars, and to which may be added imprisonment for any term not exceeding six months."

Under the authority of this act, the commissioner of the land office prescribed certain rules, the fourth and sixth of which were as follows:

"(4) Every owner or manager of a sawmill, or other person, felling or removing timber under the provisions of this act, shall keep a record of all timber so cut or removed, stating time when cut, names of parties cutting the same or in charge of the work, and describing the land from whence cut by legal sub-divisions if surveyed, and as near as practicable if not surveyed, with a statement of the evidence upon which it is claimed that the land is mineral in character, and stating also the kind and quantity of lumber manufactured therefrom, together with the names of parties to whom any such timber or lumber is sold, dates of sale, and the purpose for which sold, and shall not sell or dispose of such timber, or lumber made from such timber, without taking from the purchaser a written agreement that the same shall not be used except for building, agricultural, mining or other domestic purposes within the state or territory; and every such purchaser shall further be required to file with said owner or manager a certificate, under oath, that he purchases such timber or lumber exclusively for his own use and for the purposes aforesaid."

"(6) Timber felled or removed shall be strictly limited to building, agricultural, mining and other domestic purposes, within the state or territory where it grew."

The defendant contended in the court below that he was a person authorized by the act to cut the timber in question, and evidence was given bearing upon the question of his residence at the time when the timber was cut and manufactured into lumber. The defendant claimed that he was a resident of South Dakota within the meaning of the act. No doubt this was a question involved in the issue. Certain evidential facts bearing upon it are stated in the findings of the court, as follows:

"That the defendant, at the time the logs were cut and the lumber manufactured and disposed of, was a citizen of the United States, living at Grand Rapids, Michigan, where he has resided for the last 54 years, during which time that place, and no other, was his voting domicile, and his principal interests and business were during all of that time, and still are, in the city of Grand Rapids, Mich. In 1879 he went to Spearfish, then a small hamlet in the Black Hills, about 15 miles from Deadwood, where he developed a

small water power for making sashes, doors, and blinds. He also put up a stucco mill for grinding plaster rock found in the hills, and built there three or four substantial dwelling houses, and invested about \$20,000 in the developing of his business at that place. Connected with his business at Spearfish was a small sawmill of six or eight thousand feet daily capacity, known as the 'Iron Creek Mill,' in the mountains, about 11 miles from Spearfish, in the mineral district, and the trees were cut from these located mineral lands at a distance of from one-half to three-quarters of a mile from the Iron Creek Mill, where the logs were sawed into lumber. This Iron Creek Mill was built in 1891, and the timber was cut and the logs sawed into lumber during the three summers next following. For 17 years following his first visit at Spearfish he spent three, four, or five months there during every summer attending to his business interests. During all of these 17 years he had resident agents looking after and attending to his interests, which included a lumber yard at Spearfish. He had two married daughters and one son living there, with whom he lived while he was there."

But this falls short of a finding of the ultimate fact as to whether he had a residence in South Dakota. Perhaps, upon balancing the facts, the conclusion might be drawn that he had no residence there. If so, it was for the trial court to state it. If the question were one of domicile, it might be admitted that the facts recited were cogent evidence that the defendant's domicile was all the while in Michigan. But a man may have a domicile in one place and a residence in another for business, health, pleasure, or for other purposes; that is to say, he may have the residence on which his domicile is maintained, and another residence for business or other purposes at another place. The statement that the defendant resided for 54 years at Grand Rapids is to be taken in connection with the other statement that he was carrying on business in South Dakota for 17 years, and spent 3, 4, or 5 months of each of those years at his place of business there, attending to it, and "lived" with members of his family resident there. A residence may be temporary with the *animo revertendi* to his place of domicile. One of the definitions given in the dictionaries of the word "live" is "to dwell, to reside, to abide." We do not make these propositions with a view to decide any question of fact in the present case, but only to show that the facts found do not necessarily establish the fact that the defendant was not a resident of South Dakota.

By section 649, Rev. St. [U. S. Comp. St. 1901, p. 525], it is provided that, when trial by jury is waived, and the issues of fact are determined by the court, "the finding of the court upon the facts, which may be either general or special, shall have the same effect as the verdict of a jury." But the finding must be either one or the other, general or special, and its effect is to be determined upon its character in that regard. As was said by the supreme court in *Norris v. Jackson*, 9 Wall. 125, 19 L. Ed. 608:

"A special finding is not a mere report of the evidence, but a statement of the ultimate facts on which the law of the case must determine the rights of the parties; a finding of the propositions of fact which the evidence establishes, and not the evidence on which those ultimate facts are supposed to rest. * * * Whether the finding be general or special, it shall have the same effect as the verdict of a jury; that is to say, it is conclusive as to the facts so found. * * * In the case of a special verdict [finding] the question is presented as it would be if tried by a jury, whether the facts thus found require a judgment for plaintiff or defendant."

And in *Raimond v. Terrebonne Parish*, 132 U. S. 192, 194, 10 Sup. Ct. 57, 33 L. Ed. 309, Mr. Justice Gray, in delivering the opinion of the court, said:

"By the settled construction of the acts of congress defining the appellate jurisdiction of this court, either a statement of facts by the parties, or a finding of facts by the circuit court, is strictly analogous to a special verdict, and must state the ultimate facts of the case, presenting questions of law only, and not to be a recital of evidence or of circumstances which may tend to prove the ultimate facts, or from which they may be inferred."

And in *The E. A. Packer*, 140 U. S. 360, 365, 11 Sup. Ct. 794, 35 L. Ed. 453, Mr. Justice Brown, referring to sections 649 and 700, [U. S. Comp. St. 1901, pp. 525, 570] observed:

"The findings of the court under these sections are treated as a special verdict, and are gauged by the rules applicable to them (*Norris v. Jackson*, 9 Wall. 125, 19 L. Ed. 608; *Insurance Co. v. Copelin*, 9 Wall. 461, 467, 19 L. Ed. 739; *Wayne Co. v. Kennicott*, 103 U. S. 554, 26 L. Ed. 486); and, as was said in *Graham v. Bayne*, 18 How. 60, 63, 15 L. Ed. 265, if a special verdict be ambiguous or imperfect,—if it find but the evidence of facts, and not the facts themselves, or finds but part of the facts in issue, and is silent as to others,—it is a mistrial, and the court of error must order a venire de novo."

Hence it follows that when, as here, the finding is special, the facts found should be sufficient to support the judgment, and this means the essential facts, and not those probative facts from which the essential facts may be inferred. It appears from the record that counsel for the defendant submitted a request for a finding as follows:

"As a matter of law, I find that the defendant, at the time the logs were cut and the lumber manufactured and disposed of, was a bona fide resident of South Dakota, within the meaning of the act of June 3, 1878, and, further, that, if the defendant is found liable at all for the 517,000 feet of lumber, he should only be charged with the stumpage of the logs in the tree or the value of the logs at the Iron Creek Mill."

This was refused. Counsel for the United States urge that the refusal amounts to a finding that the defendant was not a bona fide resident of South Dakota. But this is not so, for the finding requested included the determination of the measure of damages in the way proposed if the defendant should be held liable, and this determination would have been inconsistent with the finding of the court upon that subject, as the sequel shows. For aught we can know, the refusal may have rested upon this latter ground. But probably the right construction of the findings of the court is that it intended to pretermitt the finding of the ultimate fact of residence; for, having found that, although the defendant kept a set of commercial books at his lumber yard, yet that those books were not kept with any intention of complying with the rules and regulations of the secretary of the interior (meaning, as we suppose, the commissioner of the land office), and the books did not in any sense comply with such rules and regulations, proceeded to determine as matter of law "that the cutting and removing of the timber by the defendant * * * without complying with the rules and regulations as the secretary of the interior had prescribed, * * * made the defendant a trespasser from the beginning, and as such liable for all

the timber which he cut from those lands, and that he is liable for the value at the time he parted with the property, with no deduction for the outlay of labor and money he put upon it," which included the cutting and drawing the timber to his sawmill at Iron Creek, its manufacture into lumber there, and its removal thence to his lumber yard at Spearfish. In respect to the failure of the defendant to comply with the above-mentioned rules and regulations, the court found it "was due to his ignorance of such rules and regulations." Upon the subject of values the court found that the timber, when standing upon the lands, was of no value; that when brought to the mill at Iron Creek, where some of it was sold, it was worth \$3 per 1,000; that when sawed, in which condition some was sold, it was worth there \$8 per 1,000; and that after it had been removed to Spearfish, where the principal part of it was sold, it was worth \$13 per 1,000.

From what has been stated, it would appear that the fault of the defendant, on which he was adjudged liable, consisted in his failure to comply with the rules and regulations prescribed by the land department, in that he did not keep the records and statements required thereby, and which failure was due to his ignorance of such rules and regulations. In such circumstances we think it admits of question whether it would be proper to charge the defendant with the whole value of the lumber after it had been cut, manufactured, and brought to a place where it was marketable, and when in fact the whole value of the property with which the defendant is charged consisted of the labor and money he had expended upon it. The measure of damages in such cases depends upon the question whether the defendant contributed value to the article converted with knowledge that he had no right to thus deal with it. And we are quite unable to perceive how the situation is aggravated by attributing to the act of conversion the quality of a trespass *ab initio* which presupposes that the cutting was not in itself unlawful, but became so by reason of the failure to make the proper record. The law looks to the state of mind with which the act itself was done to see if it was of a character to so infect the improvement as that the actor ought to be deprived of all benefit from his outlay.

The rule laid down in the case of *Bolles Wooden Ware Co. v. U. S.*, 106 U. S. 432, 1 Sup. Ct. 398, 27 L. Ed. 230, and which has ever since been followed in the federal courts, was this: When the defendant is a willful trespasser, the plaintiff is entitled to recover the full value of the property at the time and place of demand or of suit brought, with no deduction for his labor and expense. But when the defendant is an unintentional or mistaken trespasser, or an innocent vendee from such trespasser, the value at the time of conversion, less the amount which he or he and his vendor have added to its value, constitutes the measure of damages. Later cases, where this rule has been followed and applied, are: *Benson Mining & Smelting Co. v. Alta Mining & Smelting Co.*, 145 U. S. 428, 12 Sup. Ct. 877, 36 L. Ed. 762; *U. S. v. Mock*, 149 U. S. 273, 13 Sup. Ct. 848, 37 L. Ed. 732; *Fisher v. Brown*, 37 U. S. App. 407, 17 C. C. A. 225, 70 Fed.

570; *Gentry v. U. S.*, 41 C. C. A. 185, 101 Fed. 51; *U. S. v. Van Winkle*, 51 C. C. A. 533, 113 Fed. 903. In *Fisher v. Brown*, supra, a case decided by this court, Judge Taft, delivering the opinion, said: "The rule which forfeits to the owner the added value conferred by the labor and money of the trespasser is a punitive one, and should not be made to apply to the innocent purchaser when it can be avoided,"—a proposition which, in principle, and as the authorities show, has equal application to one who, although a trespasser, is not a willful one. No doubt it is open to say that the defendant was negligent in not informing himself of the rules and regulations of the commissioner. Still, if the fact was that he was ignorant of them, and there was no actual bad faith, his trespass would not subject him to the severer rule.

These considerations bear also upon another subject, to which we now recur. The facts recited in the findings show that the defendant may have supposed that he had such residence as authorized him to cut the timber. But here, also, we are confronted with a similar situation to that existing in the record relating to the question already considered, namely, that, although the facts are stated in the finding from which an inference might be drawn with respect to the conclusion as to whether the plaintiff in error in good faith believed himself to be a resident of South Dakota, and within the authority of the act in cutting the timber, no conclusion is in fact made in the finding. This question has an important bearing upon the measure of damages, for, although the defendant was a trespasser, the rule applied by the court below was only applicable to a case of willful trespass.

The judgment must be reversed, and a new trial ordered.

THE ATLANTIS.

(Circuit Court of Appeals, Sixth Circuit. January 6, 1903.)

Nos. 1,094, 1,095.

1. COLLISION—CONTRIBUTORY FAULT—PRESUMPTION.

The fault of an overtaking vessel for a collision being established, in determining the question of the contributory fault of the vessel overtaken, every reasonable doubt should be resolved in her favor.

2. SAME—OVERTAKING VESSELS—EFFECT OF SUCTION.

The *Owen*, a large and heavily laden steamer, passing up the Detroit river, overtook and attempted to pass the *Atlantis*, a much smaller vessel, and while so passing the *Atlantis* sheered and came into collision with the *Owen*. It did not appear that the sheer was due to any action of her helm, but rather that it was the effect of suction caused by the *Owen*, and that the helm was not changed until the effect of the suction was felt, when it was used in an effort to overcome it. Held that, it being the duty of the *Owen*, as the overtaking vessel, to keep out of the way and to pass at a safe distance, taking into account the danger from suction, the *Atlantis* was not in fault for not changing her course to give more room, even if it could safely have been done, which was a matter in dispute, nor because of any unskillful maneuvers attempted in extremis, but that the fault was solely that of the *Owen* in coming too close to the *Atlantis* without necessity.

Appeals from the District Court of the United States for the Eastern District of Michigan.

Gray & Gray (Shaw, Warren, Cady & Oakes, of counsel), for libellant.

S. S. Babcock (Frank H. Canfield, of counsel), for respondents.

Before LURTON, DAY, and SEVERENS, Circuit Judges.

DAY, Circuit Judge. The merits of the controversy arising from the collision between vessels navigating the Detroit river are presented in case No. 1,094, being an appeal from a decree in admiralty holding both steamers responsible for the resulting disaster. The colliding vessels were the John Owen and the Atlantis, the former owned by the J. Emory Owen Transportation Company, and the latter by John W. Snook. The steamer Owen was a vessel of steel and wood; length of keel, 281 feet, over all 300 feet, with a beam of 41 feet, and a depth of 20 feet. The Atlantis was a much smaller steamer; 109 feet keel, 117 feet over all, 22 feet beam, and 6 feet depth of hold. At the time of the collision both boats were bound up the river, the Owen laden with 3,000 tons of coal, and drawing 16 feet, and the Atlantis with 250 tons of coal, and drawing 8 feet 6 inches aft, and 6 feet 4 inches forward. The collision occurred in the early morning of October 28, 1898. It was moonlight and clear, and very little wind was blowing. The place of collision was probably 600 feet below the South lightship, at the cut known as the "Lime Kiln Crossing." The Owen, which was the overtaking boat, had blown the passing signal of two blasts, which was responded to by the Atlantis with a consent signal. Just as the Owen was about to turn from the Bois Blanc range on to the North and South ranges, going up the cut, her captain sung out to the officer in charge of the Atlantis to "look out for himself," and, putting his helm to starboard, started to make the swing on to the North and South ranges. While the stern of the Owen was swinging toward the Atlantis, the latter vessel, which was on the starboard side of the Owen, was either drawn or steered in such way as to take a sudden sheer to port against the Owen, the vessels coming in contact in such wise that the Atlantis was held against the Owen until, by the backing of the vessels, she was released, and passed astern of the Owen. The effect of the collision was to send the Owen to the eastward upon the rocks, doing her considerable damage. The learned judge who tried the case in the district court found both vessels at fault, and divided the damages. From this decree the Owen did not take an appeal, and we may regard her fault as established, and need not consider that question any further than it enters into the discussion of the alleged fault of the Atlantis.

From the conflicting statements of the officers and men upon these two ships, we are to endeavor to get at the truth of this casualty, with the resulting liability of the respective vessels. It is claimed, on the one hand, that the Owen, after giving the passing signal and receiving permission to pass by the response of the Atlantis, was proceeding to do so on the port side of the Atlantis, at a slow rate of speed and at a safe distance, when the Atlantis, some 200 feet away, took a sudden sheer toward the Owen, recovered herself, and

almost immediately after regaining her course took another and more decided sheer into the Owen, striking her about 10 feet from her stern on the starboard side. On the other hand, it is asserted that the Owen came within 50 or 60 feet of the Atlantis, causing her stern first to be drawn within the influence of the suction from the Owen. This, overcome by starboarding the wheel a little, was followed by the pulling of her bow sharply to port, when the influence of the suction reached that part of the vessel, causing her to come into contact with the Owen about 10 feet from her stern, and at a point on the Atlantis 16 to 18 feet back of the stem, where she was held for a short time until she was released by the combined efforts of the two boats.

The first of these accounts, which may be called that of the Owen, seems highly improbable on its face. Whatever the rate of speed at which the Owen was passing the Atlantis,—and there is great conflict in the testimony on this subject,—it was faster than the latter vessel was going. Those in charge of the Owen place the first sheer at a time when the Atlantis' bow was opposite the pilot house of the Owen, the second when her bow was opposite a point about 75 feet from the stern of the Owen. The Atlantis is placed on a course about 200 feet from the Owen. It would seem incredible that the Atlantis, so far away, could have made these maneuvers while the Owen was going at a faster rate, and yet come into collision. It was most probable, and we think the testimony shows, that the vessels were closer together. Assuming it possible that the Atlantis could have been carried across the intervening channel by the force of her wheel alone, there is no motive for such a course, unless her navigators were willfully seeking a collision. The character of the "sheer" or "dive" of the Atlantis toward the Owen was such as clearly demonstrated the presence of some force other than the action of her rudder. *The City of Brockton* (D. C.) 37 Fed. 897.

That the smaller vessel was likely to be acted upon by the suction of the larger, we think, is apparent. It was a danger which should have been calculated upon by the navigator of the Owen. This force of suction, though the source of no little difference of opinion as to its mode of operation in a given situation, is recognized by the courts, and as well by practical navigators. It has undoubtedly been the cause of many marine collisions. Although our knowledge of its methods of operation and effects may not be reduced to an exact science, yet, as was said by Judge Lurton in the case of *The Ohio*, 33 C. C. A. 671, 91 Fed. 551: "Suction is a force to be reckoned with and to be guarded against when vessels pass in close proximity." *The Alexander Folsom*, 3 C. C. A. 165, 52 Fed. 403; *The City of Cleveland* (D. C.) 56 Fed. 729; *The Mesaba* (D. C.) 111 Fed. 215; *The Aureole*, 51 C. C. A. 181, 113 Fed. 224. It is apparent that many of the conditions most favorable to the operation of suction were here present. A large ship was passing a smaller one in a comparatively narrow and shallow channel. The theory is that the water displaced and "piled up" in front and along the sides of the passing vessel must flow back again into the opening made to accommodate the vessel as she passes along her course. The water, when it thus

begins to flow backward, exerts an influence to draw with it any passing vessel near enough to feel its effects. If the vessel is small and the channel shallow, so that more water to fill the space must come from the sides than below, it is very liable to yield to the power thus exerted and be deflected from its course. In the present case there is almost a complete demonstration of the exertion of this force by the Owen upon the Atlantis in the relation of the two vessels at the time of the collision.

What was the fault of the Atlantis? It was the duty of the overtaking vessel to keep out of the way, and to choose a place for passing which would not imperil the Atlantis. Spencer, *Collisions*, § 71, states the rule to be:

"A vessel of superior speed running astern of a slower one is not obliged to retard its own speed because of the inability of the leading ship to proceed at as great a rate. It has the right to pass if it can do so with safety to both. It must be its own judge as to the matter of safety; and, if the result shows it to have been in error as to the propriety of passing, it must suffer the consequences of its act; and the burden of proof rests upon it to show not only the prudence of her own conduct, but also the negligence of the other, where negligence is charged; and, failing to do this, she must be held accountable for the result."

Rule 22 specifically provides:

"Notwithstanding anything contained in these rules, every vessel overtaking any other shall keep out of the way of the overtaken vessel."

It was the duty of the Atlantis to hold her course. The Governor, 1 Abb. Adm. 108, Fed. Cas. No. 5,645. It was not her duty to keep away from the Owen. Undoubtedly, after the collision became imminent, it was her duty to do all that prudent seamanship required to avoid the collision. It is claimed that not only did the Atlantis contribute to the accident by faulty steering, but she could go, and under the circumstances it was her duty to go, farther to the eastward and give the Owen more room. As to the first of these claims, we have already stated our conclusion that the force which caused the Atlantis to "dive" toward the Owen was more than her rudder would likely exert. The testimony shows that the Atlantis was already to the eastward of the Bois Blanc range when she began to feel the force of the Owen's suction, drawing her stern to port toward the Owen. The mate in charge of the Atlantis gave his wheelsman the order to "watch his starboard wheel," and it was put over a short distance to starboard, almost immediately the mate noticed the bow being sharply drawn toward the Owen, and gave the order to "port—hard aport," and himself sprang to the wheel to help the man there to put and keep the wheel hard aport. In almost the same instant, the master of the Owen swung her stern to starboard with a view, as he says, to take the North and South ranges, and the collision was inevitable. Had he delayed a very short space of time, as we think he ought to have done, the collision would have been avoided. It may be that the Atlantis might have safely gone further to the eastward when the collision became imminent, but her master says that he feared the rocks on the eastern side of the channel, and was already as far over as he deemed it prudent to go. We find nothing to contradict him or to enable us to say that his

judgment was faulty. He was in extremis, placed there by the wrongful act of the Owen in unduly crowding upon the course of the Atlantis. Under such circumstances, a master may be excused if he does not maneuver with perfect skill, or even if he acts mistakenly under such pressure, or omits to do all that ought to be done. *The Elizabeth Jones*, 112 U. S. 514, 5 Sup. Ct. 468, 28 L. Ed. 812; *The Maggie J. Smith*, 123 U. S. 349, 8 Sup. Ct. 159, 31 L. Ed. 175; *The Iron Chief*, 11 C. C. A. 196, 63 Fed. 289. The same reasoning applies to the other maneuvers at the time of the collision. It may be that the wheel was put over a little too far to the starboard, although this is by no means clear, but it was the action of one seeking to avoid the sudden peril to which the misconduct of the overtaking vessel had exposed him. As to the incapacity of the Atlantis' wheelsman, he was probably not one of great skill. This fact is admitted by the mate of the Atlantis, and is evident from his manner of testifying when on the stand, but he seems to have been adequate to the situation, and to have promptly obeyed the orders of the mate given at the time. Upon the whole case, we are unable to discover any fault on the part of the Atlantis, made out by the weight of testimony, warranting her condemnation as a contributor to the injury.

In this case the fault of the Owen is established by failure to appeal, and we think the testimony leaves no doubt about its sufficiency to cause the disaster. In such contingency, it is not enough that a doubt be raised as to the propriety of the conduct of the navigators of the Atlantis. Any such reasonable doubt should be resolved in her favor. *The Livingstone*, 51 C. C. A. 560, 113 Fed. 879, and cases cited.

This conclusion renders it unnecessary to consider the question raised by the appeal in No. 1,095 as to the right to recover interest on the decree against the Atlantis. The decree of the district court, in so far as it holds the Atlantis liable, is reversed, and both causes in appeal remanded, with instructions to enter a decree holding the Owen solely at fault, with costs in favor of the owners of the Atlantis in both courts.

STANDARD OIL CO. v. MURRAY.*

(Circuit Court of Appeals, Seventh Circuit. October 7, 1902.)

No. 869.

1. **CONTRACTS—ACTION FOR BREACH—PERSONS NOT IN PRIVACY.**

An engineer, injured by an explosion of oil purchased by his employer, cannot maintain an action against the seller to recover for the injury, on the ground that the oil was not of the quality represented; such an action being grounded on a breach of the contract of sale to which plaintiff was not a party or privy.

2. **NEGLIGENCE—RIGHT OF ACTION—LIABILITY OF MAKER OF ARTICLE.**

The manufacturer and seller of an article which is essentially dangerous to person or property owes a duty to the public to use care in its manufacture, that it shall not be unnecessarily dangerous; but with respect to articles not of such dangerous nature his only liability for negligence is to the party with whom he contracts.

* Rehearing denied November 15, 1902.

8. SAME—EVIDENCE TO ESTABLISH—INFERENCE FROM CIRCUMSTANCES PROVED.

Plaintiff was injured by an explosion which followed his lighting a match to enable him to look into a tank which contained a petroleum lubricating oil manufactured by defendant. He alleged that the explosion was due to gas or vapor generated by the oil owing to negligence in its manufacture; but there was no direct evidence of such negligence, and defendant's evidence showed that it was refined with care and would not generate an appreciable amount of gas at any ordinary temperature. The tank did not explode, nor did the oil take fire. It was shown that gasoline, which would generate an inflammable vapor at a comparatively low temperature, was used in the room for lighting purposes, and there was evidence tending to show that there was a quantity in the room at the time. *Held*, that under such evidence negligence in the manufacture of the lubricating oil could not be inferred from the mere fact of the explosion.

In Error to the Circuit Court of the United States for the Northern District of Illinois.

The defendant in error, Frank Murray, brought suit in trespass on the case against the Standard Oil Company for personal injuries received by him while in the service of George O. Newberry & Co. as an engineer at a certain building in the city of Chicago. The first count of the declaration charges that Murray was an engineer in the service of Newberry & Co. and in charge of a stationary engine; that the Standard Oil Company on the 7th day of May, 1896, sold to his employer a certain quantity of oil designed for lubricating purposes, commonly known as "external engine oil"; that such oil, when properly manufactured and refined, will not under normal conditions, or when submitted to a moderate degree of heat or pressure, generate an inflammable or explosive gas; that the Standard Oil Company represented that the oil was of the usual and ordinary kind, and would not under ordinary conditions, or under a moderate degree of pressure or heat, generate or collect inflammable or explosive gas; that, notwithstanding, the oil purchased was of an impure and adulterated character, so that it evaporated, and generated and caused to be accumulated in the tank in which it was contained an inflammable and explosive gas; that on the 21st of July, 1896, while he was in the exercise of due care and engaged in the duties of his employment, there was a violent explosion of gas which had been generated and collected in the tank in which the oil was contained, whereby he was severely burned and scorched, and sustained injuries, etc. The second count charges that the Standard Oil Company was engaged in the business of manufacturing, refining, handling, and selling oil; that Murray was employed as engineer as stated in the first count; that the Standard Oil Company on the 7th of May sold to his employer for the purposes stated a certain quantity of oil designed for oiling and lubricating purposes; that the oil was of a vaporous and volatile character, likely to generate inflammable or explosive gas, as the Standard Oil Company then well knew or by the exercise of reasonable care might have known; that the company well knew that the oil was to be stored and kept in the engine room of the premises and was to be used in oiling the engine and machinery; that it was the duty of the company to warn Murray of the dangerous properties of the oil and that it was likely to evaporate and to generate inflammable or explosive gas in the tank wherein it was contained, but that the company wholly disregarded and neglected its duty and failed and omitted, in selling the oil, to warn Murray of its dangerous properties; that while he was in close proximity to the oil then remaining unused, and while in the exercise of due care, a large quantity of gas which had been generated and collected from the oil, ignited from a lighted match which Murray held in his hand, and thereupon the oil burned with a violent and explosive effect, whereby Murray sustained injuries, etc. At the trial, upon conclusion of the evidence, the Standard Oil Company requested the court to direct the jury to return a verdict for the defendant, which motion was overruled, and an exception to the ruling was duly preserved. A verdict was returned for the plaintiff below, and from a judgment rendered upon the verdict a writ of error is sued out by the Standard Oil Company.

The facts disclosed by the evidence are substantially without dispute. The Standard Oil Company on the 5th of May, 1896, sold to Newberry & Co. one barrel of "Renown Engine Oil," the highest grade of lubricating oil manufactured by the company. It has a fire test of 425° Fahrenheit, at which it burns. The oil was delivered on the 7th of May, 1896, and was pumped by Murray into a tank. The tank had no locks or padlocks. It had a hood, which could be pushed back, and upon the inside was a trap door, which could be lifted on a hinge; the pump being inserted into the barrel through the trap. Murray testified that up to the day of the accident he saw nothing to indicate that there was any gas about the oil, and he saw nothing to indicate anything injurious in connection with it. He drew from this tank of oil two or three times a day each day from May 8th until July 21st, at which time there was left of the original fifty-two gallons in the tank from five to fifteen gallons of the oil. The tank containing the oil was placed about twenty-five feet from the boiler and at the back end of the building. This boiler room was lighted with a gasoline torch and gasoline was used for that purpose during the time in question. The gasoline was kept in a barrel situated in the front basement of the building and was pumped directly into the gasoline torch through a funnel. Until the date of the injury Murray had no occasion to and did not use a light in the tank. On July 21, 1896, Murray lifted the hood and the inside cover of the oil tank, lighted a match, and leaned over the tank to ascertain the quantity of oil remaining therein, whereupon there was an explosion which threw him about seven feet against an engine, whereby he sustained injury. It was shown by the defendant that "Renown Engine Oil," such as was sold to Newberry & Co., is made from a high boiling process of the crude petroleum and is brought to certain special fire tests; the first test being 425° Fahrenheit, at which it takes fire and burns. The crude petroleum is boiled on a slow fire, and all the light boiling portion is eliminated; the gasoline and the intermediate oils being thrown off. A current of steam is introduced which removes all portions which burn at a low temperature. When the process is carried to a point where the test is sufficiently high, the oil remaining in the still is pumped into a large tank, and treated and made ready for use upon engines. From the tank it is drawn into barrels or tank cars, the barrels being new and of oak and holding about fifty gallons each. When the barrel is filled with the oil a bung first dipped in melted glue is then inserted and driven in perfectly tight, the glue allowed to set, and the barrels are then branded with the grade of oil with which the barrel is filled. It was also shown that gasoline would flash and burn at a temperature of 75° or 80°, and that "Renown Engine Oil" made by the Standard Oil Company would not explode under the circumstances detailed by the plaintiff and at the ordinary temperature of an engine room, or generate any appreciable amount of gas. It was also shown by the testimony of the superintendent of the company that, while gasoline would explode, he had never known lubricating oil to explode, and that only new barrels were used for "Renown Engine Oil." There was dispute of testimony with respect to a supposed custom obtaining in Chicago in 1896 to ascertain the method of discovering the amount of oil remaining in the tank,—the evidence on the part of Murray being that it is customary to use a lighted match and sometimes to use a rod; the evidence on the part of the company being that the custom was to use a graduated measuring stick as a gauge, or an ordinary rod, and that one could not tell by means of a light the amount of oil remaining in the tank. The evidence for the defendant below tended to show that on the day following the explosion the tank was in perfect condition, that a quart measure was upon the inside cover of the tank, having the odor of gasoline, and that a five-gallon can of gasoline was located about fifteen feet from the tank and a like distance from the boiler, and that gasoline would explode when in contact with a lighted match, but that the oil would not.

Alfred D. Eddy, for plaintiff in error.

R. M. Wing and T. L. Chadbourne, for defendant in error.

Before JENKINS, GROSSCUP, and BAKER, Circuit Judges.

JENKINS, Circuit Judge, delivered the opinion of the court.

1. There can be no recovery under the first count of the declaration. Murray's employer, and not Murray, was the purchaser of the oil. There was no privity of contract between the Standard Oil Company and Murray, and a breach of that contract cannot be taken advantage of by him. *Bank v. Ward*, 100 U. S. 195, 25 L. Ed. 621.

2. The second count proceeds upon the ground that the oil was sold to Murray's employer to be used by Murray in that service, as the Standard Oil Company knew; that the oil was of a vaporous and volatile character, likely to generate inflammable or explosive gas, as the oil company knew or ought to have known; and the company failed to warn Murray of the dangerous properties of the oil as was its duty. We said in *Goodlander Mill Co. v. Standard Oil Co.*, 24 U. S. App. 7, 11 C. C. A. 253, 63 Fed. 400, that:

"It is not every one who suffers loss from another's negligence who may recover therefor. Negligence, to be actionable, must occur by breach of a legal duty arising out of contract, or otherwise owing to the person sustaining the loss. *Kahl v. Love*, 37 N. J. Law, 5; *Sav. Bank v. Ward*, 100 U. S. 195, 25 L. Ed. 621. Mr. Wharton defines legal duty to be 'that which the law requires to be done or forborne to a determinate person or to the public at large, and as correlative to a right vested in such determinate person or the public at large.' Wharton, *Neg.* (2d Ed.) § 24."

The acceptance by a vendee of a thing sold, except under special circumstances, relieves the vendor from liability to a stranger for an injury resulting to him from the negligent manufacture or construction of the thing sold. *Bragdon v. Perkins-Campbell Co.*, 30 C. C. A. 567, 87 Fed. 109; *Necker v. Harvey*, 49 Mich. 517, 14 N. W. 503. The duty owing to the public, for breach of which one injured may recover, has respect to and is limited to instruments and articles in their nature calculated to do injury, such as are essentially and in their elements instruments of danger, and to acts that are ordinarily dangerous to life and property. If the wrongful act be not immi- nently dangerous to life or property, the negligent vendor is liable only to the party with whom he contracted. *McCaffery v. Manufacturing Co. (R. I.)* 50 Atl. 651, 55 L. R. A. 822. Petroleum oil, as we held in *Goodlander Mill Co. v. Standard Oil Co.*, *supra*, and in *Railway Co. v. Ballentine*, 28 C. C. A. 572, 84 Fed. 935, is not a dangerous agency within the rule that he who uses it does so at his peril. It is dangerous only when in considerable quantities it is brought into contact with fire. That is a fact of common knowledge, with which every one is chargeable.

3. There was no proof of negligence in the manufacture of the oil, unless culpable negligence is to be inferred from the mere fact of an explosion. We do not doubt the rule that an accident may be of such a nature that presumption of negligence will be indulged from its happening. The evidence here shows that the oil was refined with care, and at the ordinary temperature of an engine room would not generate an appreciable amount of gas, and that it would not take fire or burn at a less temperature than 425° Fahrenheit, while gasoline will at a temperature of 80°. The temperature of the room at the time of the injury was 95°. The oil had been in the possession of Murray's employer, and in the care of Murray, for more than

two months. It was placed in the room in which gasoline was used. There was an explosion upon igniting the match, but the oil did not take fire. Gasoline at an ordinary temperature gives off an inflammable vapor, impregnating the air, and, in contact with flame, causing an explosion. Under such circumstances no presumption of negligence can arise with respect to the manufacture of the oil.

4. The cause of the explosion rests in mere speculation. It may have occurred from the presence of gas generated from the oil, or more probably from the presence of gasoline, in conjunction with flame from a lighted match. The burden of proof was upon Murray, assuming that he could avail himself of negligence in the manufacture of the oil. None was shown, the mere fact of the explosion under the circumstances raising no presumption of negligence. It is not, therefore, necessary to consider the question whether, assuming negligence in the manufacture of the oil, such negligence was the proximate cause of the injury; or whether the act of lighting the match was not an intervening cause, superseding the original wrong, so as to make it remote in the chain of causation, although it may have remotely contributed to the injury as an occasion or condition.

The judgment is reversed, and the cause remanded, with a direction to grant a new trial.

GEORGE CARROLL & BRO. CO. et al. v. YOUNG.

(Circuit Court of Appeals, Third Circuit. January 7, 1903.)

No. 24.

1. BANKRUPTCY—RIGHTS OF LIEN CREDITORS—SALE OF PROPERTY AS AN ENTIRETY.

The principal asset of a bankrupt corporation was its manufacturing plant, consisting of a building on ground leased for a term of years and the machinery and appliances therein used by the bankrupt in carrying on its business, upon which there were various liens. Certain creditors, having valid mechanics' liens for the price of materials used in the construction of the building, which under the statute bound the building and the leasehold interest of the bankrupt in the land, objected to the granting of an order authorizing the trustee to sell the property as an entirety free from liens, upon the ground that all lien creditors did not stand upon the same basis, and that, in case of such sale, it would be impossible to tell how much of the fund each represented, or against what portion it could be enforced. The order was made, but "without prejudice to the right of lien creditors to claim from the fund derived from the sale the amount of their respective liens." *Held*, that the objection made and such proviso in the order fully protected the lien creditors in the right to assert their preferences against the fund, without the necessity of excepting to the return of sale, and that it was the duty of the referee to recognize and enforce such right, taking evidence, if necessary, to determine as nearly as possible what portion of the proceeds of the sale represented the property covered by their liens.

Appeal from the District Court of the United States for the Western District of Pennsylvania.

Henry A. Clark, for appellants.

John S. Rilling and Henry E. Fish, for appellee.

Before ACHESON, DALLAS, and GRAY, Circuit Judges.

ACHESON, Circuit Judge. The principal asset of the bankrupt, the Hygeian Milk Company, was its manufacturing plant, being a two-storied brick building equipped with boiler and engine, vats, pumps, tanks, and other machinery for making condensed milk, which the bankrupt had erected upon a piece of land in the city of Erie, county of Erie, Pa., held by the bankrupt under a lease for years. The appellants, the George Carroll & Brother Company and James McCarty, respectively, had furnished materials (the former, woodwork and lumber to the amount of \$1,246.93; the latter, brick to the amount of \$1,451) for the construction and erection of this building. Each of these parties for the materials so furnished by them had filed a lien under the provisions of the acts of assembly of Pennsylvania, and more particularly under the acts of February 17, 1858 (P. L. 29), and April 11, 1866 (P. L. 649), which extend the lien law to the interest of tenants of leased estates for "all improvements, engines, pumps, machinery, screens, and fixtures" erected by such tenants on leased lands in certain counties, including the county of Erie. The lien of the George Carroll & Brother Company, after reciting that the building stands on land leased by the Hygeian Milk Company, states that the lien is filed "against the interest of the said Hygeian Milk Company in said building and the said leased lot or piece of ground and curtilage appurtenant to said building." The lien of James McCarty states that he files his claim "against the Hygeian Milk Company, lessees of the premises hereinafter more fully and particularly described, and for material furnished for the construction and erection of a two-story building, with basement, on said premises, and against the building and the ground covered thereby, and so much other ground immediately adjacent thereto and leased to the said Hygeian Milk Company as may be necessary for the ordinary and useful purposes of the same; * * * and the lien is filed against the leasehold interest of said Hygeian Milk Company in the hereinafter described land and building, under the provisions of the acts of assembly of Pennsylvania," etc.

The referee in bankruptcy in his final report states that "the lien of the George Carroll & Brother Company, as amended, seems to be in proper form as required by the act of April 17, 1858," but that the lien of James McCarty is open to the objection that it is "not against the interest of the tenant in the specific improvement." In making this distinction, evidently the referee overlooked that part of the McCarty lien last above quoted. Both liens were filed against the interest of the tenant of the leased premises in the building and ground covered by the building, and so much ground adjacent and belonging thereto as is necessary for the ordinary and useful purposes of the building. There is no substantial difference between these liens in their terms, and we think that each of them complies with the statutory requirements. *Thomas v. Smith*, 42 Pa. 68, 73; *Association v. Kearns*, 103 Pa. 403, 407, 408. These cases decide that a building for business purposes erected by a tenant of a leased estate upon the leased land is an "improvement," within the meaning of the act of February 17, 1858, and that such building, together with the ground covered by it and so much adjacent ground as is necessary for the enjoyment of the building (to the extent of the interest of the tenant therein), is subject

to liens for work done and for materials furnished for the erection of such building. We are of the opinion that the trustee in bankruptcy here took the estate of the bankrupt subject to the liens of these appellants as filed by them, respectively.

The trustee presented to the referee in bankruptcy a petition setting forth the filing of six liens (including those of the appellants) against the property, and that it "would be impossible to realize but a small portion of the value of said building by selling the same in parcels or portions, or attempting to sell said property with said alleged liens attached," and praying for an order authorizing him to sell the property divested of all liens. The appellants each filed written exceptions to the granting of this petition. The referee, however, notwithstanding their objections, made an order that the trustee sell the property "divested of all liens, without prejudice to the right of lien creditors to claim from the fund derived from said sale the amount of their respective liens." In his return of sale the trustee reported that, "certain alleged mechanic's lien creditors" having objected to the sale of the plant as an entirety and requesting a sale of the machinery and building separately, he offered the property in three parcels, thus: First, the condensing machinery, the highest bid therefor being \$1,000; second, the leasehold, building, boiler, sewerage, plumbing, and electric wiring, the highest bid therefor being \$2,200; third, the engine, general plumbing, pulleys, belts, and shafting, the highest bid therefor being \$150,—and that he then offered the three parcels together, and so sold them for \$4,425. Afterwards, under an alias order made by the referee, the trustee sold the property as an entirety for the sum of \$5,035.

Upon the distribution of the fund by the referee the appellants claimed as secured creditors by virtue of their liens. The referee, however, disallowed their claims to preference and awarded them only pro rata dividends with the general creditors. In concluding his report the referee said:

"The sale was made of the plant as an entirety, was so returned by the trustee without exception filed by said claimants, and the first time the question was fully argued, and the special, limited nature of the claimants' liens brought to the attention of the referee, was on the hearing for dividend. Whatever power the referee might have had to protect the rights of these lien claimants, if invoked in time, I am of the opinion that it is now too late for him to afford them any relief."

The learned district judge, in a brief opinion sustaining the referee, said:

"The property having been sold as a whole without objection by them, they having no lien on it as a whole, and there being nothing, moreover, in the record to show the proportionate value of any individual part to the gross purchase price, it is clear the referee rightly refuses to award preference to the claimants."

We are not satisfied with the result. It is our conviction that injustice was done the appellants. The reasons assigned by the referee and the court for depriving them of the benefit of their liens strike us as inadequate. We cannot shut our eyes to the fact that these appellants in limine filed objections to such a sale as the trustee proposed and eventually made, namely, a sale of the property as an entirety, de-

vested of all liens. The third objection filed by each of them pointed out with sufficient distinctness the very difficulty which is now brought forward as a bar to their rights as lien creditors. That objection was as follows:

"Third, because all lien creditors do not stand upon the same basis, and, in the event of the leasehold interest, building, and the entire plant being converted into money, it would be impossible to tell how much of that fund each lien represented, and against what portion of it the lien might be enforced."

Moreover, the order of sale, while divesting all liens, contained this provision:

"Without prejudice to the right of lien creditors to claim from the fund derived from said sale the amount of their respective liens."

These lien claimants had a right to rely on this condition of the order of sale. In view thereof, it cannot fairly be urged against them that they did not file exceptions to the return of sale. That condition in the order of sale was a sufficient warrant for these claimants to go before the referee as secured creditors upon the distribution of the fund.

Again, it seems to us that there is in this record some evidence, namely, the first return of the trustee to the order of sale, tending to show the proportionate value of the particular part bound by the liens of the appellants to the gross purchase price. But, if the evidence on that point was incomplete, we think that the referee *sua sponte* should have taken additional proof to show the portion of the purchase price representing the building and its ground, apart from the machinery and other equipment.

It is too late to question the propriety of the order of sale which the referee made. Nor can the sale as made by the trustee be disturbed now without injustice to innocent parties. The purchase price was paid and the sale consummated. Then, too, time has been running against the term of the lease. Happily, however, the appellants are not remediless. We can open the referee's report and scheme of distribution so far as to permit these appellants as secured creditors to prosecute their claims to preference against the fund.

The decree of the district court is reversed in so far as it affected the appellants, with costs to be paid out of the estate of the bankrupt, and the cause is remanded to the court below, with direction to recommit the case to the referee in bankruptcy, with instructions to open the matter of distribution so far as to permit the George Carroll & Brother Company and James McCarty to prosecute their claims as preferred lien creditors against the fund.

McCAULLEY v. CITY OF PHILADELPHIA.

(Circuit Court of Appeals, Third Circuit. January 7, 1903.)

No. 21.

1. NAVIGABLE WATERS—OBSTRUCTIONS—NEGLIGENCE OF CITY.

A city, although charged by statute with the duty of keeping the channels of navigable streams within its limits free from obstructions, cannot be held liable for an injury caused by a sunken wreck, where the owner had in due time undertaken its removal through the agency of a reputable and experienced wrecking company, which was proceeding with apparent diligence and good faith and by customary methods.

2. SAME—JURISDICTION ASSUMED BY UNITED STATES.

Where the war department of the United States has taken charge of the removal of a sunken wreck in a navigable stream under authority of an act of congress, its jurisdiction in the matter is exclusive, and a city cannot be held negligent in failing to take action for its removal.

3. SAME—STATUTORY LIABILITY—CITY OF PHILADELPHIA.

Act Pa. April 14, 1859 (P. L. 643), which places on the warden of the port of Philadelphia, who is a state officer, the duty of removing any vessel "sinking in the channel way of the tide waters of the river Delaware or the river Schuylkill within the limits of the port of Philadelphia," modified the general provisions of section 28 of the consolidation act of February 2, 1854 (P. L. 37), which imposed upon the city of Philadelphia the duty of keeping the navigable waters within the city open and free from obstructions, so far as related to sunken vessels of the character described.

Appeal from the District Court of the United States for the Eastern District of Pennsylvania.

For former opinions, see 103 Fed. 661, and 116 Fed. 438.

Horace L. Cheyney, for appellant.

Chester N. Farr, Jr., for appellee.

Before ACHESON, DALLAS, and GRAY, Circuit Judges.

ACHESON, Circuit Judge. In this suit the libellant (here the appellant) sought to recover from the city of Philadelphia damages which the ship Windsor Park sustained on December 29, 1893, while being towed up the Schuylkill river, by reason of the collision of the ship with the wreck of the steamer Maryland, which was lying in the river a short distance below Point Breeze, within the city. The action was based and pressed upon the provisions of section 28 of the act of assembly of February 2, 1854 (P. L. 37), commonly called the "Consolidation Act," which provides in part as follows:

"It shall be the duty of the said councils, after the requisite surveys and soundings shall have been made, to fix the lines beyond which no wharf or pier shall be constructed, and to keep the navigable waters within said city forever open and free from obstructions."

The libel set forth that the wreck of the Maryland had been lying in the river since November, 1892, and charged that the city of Philadelphia was negligent in not having removed the wreck from the river before the happening of the collision. The learned district judge, while assuming that section 28 of the consolidation act was applicable to this case (103 Fed. 661; 116 Fed. 438), yet upon the facts shown by the proofs found that the charge of negligence contained

in the libel against the city was not made out, and hence dismissed the libel.

It appears that in November, 1892, in a destructive fire which occurred at Point Breeze, the steamer Maryland took fire, and that she was towed down stream a short distance, and run ashore upon the east bank of the Schuylkill river, where she sank in such a position that 50 or 60 feet of her length projected into the channel of the river. Very soon thereafter the wreck was sold to a responsible purchaser, who immediately contracted with a competent and experienced contractor—the Mason Wrecking Company—to raise and remove the wreck. The wrecking company began work early in March, 1893, which the evidence satisfactorily shows was as soon as weather conditions permitted. The work seems to have been prosecuted very diligently and with reasonably proper machinery and appliances. At first considerable progress was made toward removing the obstruction, and success seemed to be assured. In his letter (in evidence) dated May 11, 1893, to the Atlantic Refining Company, in reply to its complaint that the wreck "has shifted," etc., Maj. C. W. Raymond, the head of the corps of United States engineers stationed at Philadelphia, wrote:

"I have had an investigation made of the wreck and its locality, and it appears that the owner of the wreck, Mr. Fred. Creamer, of Camden, N. J., has been at work for some time making efforts to raise it with pontoons, and had practically succeeded in beaching it, when the extra strain caused by the freshet of last week parted his hawsers and sling chains, which permitted the vessel to be carried a short distance toward the channel. I understand that Mr. Creamer is again at work readjusting his chains and preparing to raise and beach the vessel. If the obstruction is not out of the way within a reasonable time, authority will be requested to remove it under the provisions of the act of congress approved June 14, 1880."

The Mason Wrecking Company renewed and continued its efforts to remove and beach the wreck with at least some show of success, but about the last day of August the wreck again slid down into the channel. On September 13, 1893, Major Raymond, in a written report to the war department, recommended the removal of the wreck by the general government, pursuant to the act of congress of June 14, 1880. Accordingly, on September 18th he advertised for proposals, and on September 28, 1893, the notice required by the act of congress of the purpose of the secretary of war to remove the wreck was given. On October 30, 1893, the Mason Wrecking Company applied to Maj. Raymond for an allowance of 30 days' more time for the removal of the wreck by that company, and this extension of time was granted by the war department upon the recommendation of Maj. Raymond, who, in his letter to the department of October 30, 1893, stated: "A recent examination shows that the wreck is not now in the way of passing vessels." The wrecking company, however, failed to remove the wreck within the extended time, and on December 19, 1893, the United States government entered into a contract with other wreckers for its removal, work to commence on December 31, 1893, and to be finished on January 31, 1894.

We do not see that the learned district judge erred in his findings of fact, and, even upon the assumption that section 28 of the consolidation act is still in full force, we agree with his conclusion that the

proofs did not convict the city of negligence. The city was not bound to intervene after the owner of the wreck within due time had undertaken its removal through the agency of a reputable and experienced wrecking company, while that company was proceeding with apparent diligence and good faith and by a customary method.

It may be that the act of congress of June 14, 1880, which makes it the duty of the secretary of war to cause the removal of any sunken vessel or water craft which shall obstruct or endanger the navigation of any river or navigable water of the United States, does not wholly supersede the state law relative to the removal of sunken vessels lying in the waters of the rivers Delaware and Schuylkill within the port of Philadelphia. But the important fact here is that as early as the month of September, 1893, the war department of the United States had interposed under the act of congress and taken charge of the matter of the removal of the wreck of the steamer Maryland. The war department advertised for proposals, gave the required notice of the purpose of the secretary of war, granted to the Mason Wrecking Company an extension of 30 days, and at the expiration of this extension made a contract for the removal of the wreck. All this took place before this collision, and such was the situation on December 29, 1893, when the collision occurred. Now, it is clear, we think, that after the secretary of war had taken action, and while he was proceeding under the act of congress, the authorities of the city of Philadelphia were precluded from acting with respect to this wreck. The jurisdiction of the secretary of war, having actually attached, was necessarily exclusive.

Here we might well rest the case. Our attention, however, having been particularly directed to the Pennsylvania act of April 14, 1859 (P. L. 643), relative to the duties of the master warden of the port of Philadelphia with respect to sunken vessels, it seems proper to give this act consideration. The act provides that it shall be the duty of the master warden of the port of Philadelphia, upon the sinking of any canal boat, barge, or other vessel "in the channel way of the tide waters of the river Delaware or river Schuylkill within the limits of the port of Philadelphia," to give notice to the owner, master, or other agent having charge thereof to raise and remove such obstruction within 10 days, under a penalty of \$100, and, in case of the refusal or neglect of the parties interested as aforesaid to raise and remove such obstruction, it shall be the further duty of said master warden to have it raised and removed at the expense of the owner, master, or agent, and he shall have a lien on the vessel and cargo for all expenses; and the subsequent act of May 20, 1864 (P. L. 906), authorizes the master warden to recover from the owner, master, or agent having control of said vessel, by a personal suit, the expenses of raising, removing, and selling the vessel, together with the penalty aforesaid and costs. The master warden of the port of Philadelphia is a state officer, appointed and commissioned by the governor. The act of 1859 distinctly imposes upon the master warden of the port of Philadelphia, a state, and not a city, official, the special duty of raising and removing vessels sinking "in the channel way of the tide waters of the river Delaware or river Schuylkill within the limits of the port of Philadelphia." This act does not repeal section 28 of the consolidation act, but we think

that it works a modification of the general language of that section to the extent of the particular duty thus imposed upon the master warden of the port. This construction harmonizes the two enactments. The specific duty of raising and removing vessels sinking "in the channel way of the tide waters" of the rivers within the port limits is put upon the master warden of the port, while the duty to keep the navigable waters open and free from all other obstructions remains upon the city. This was the construction given to the act of 1859 by the district court of Philadelphia in *Winpenny v. City of Philadelphia*, 7 Phila. 111. The opinion of Judge Thayer, enforcing this view, is very convincing. It is true that the judgment of nonsuit entered in that case was reversed by the supreme court of Pennsylvania. *Winpenny v. City of Philadelphia*, 65 Pa. 135. The reversal, however, was wholly upon the ground that the case before the court did not fall within the scope of the act of 1859. The obstruction which did the mischief there complained of was held not to be within the terms or the intent of that act. The obstruction was occasioned by an abandoned coal barge, which had been wrecked in the upper waters of the Schuylkill and brought down by a freshet and lodged within the port limits of the city of Philadelphia. The supreme court in its opinion said:

"It was not a trading vessel, or a boat, or barge, capable of use, but an old and worthless wreck, which had drifted off and lodged and became embedded in the mud. It did not sink, within the letter or the spirit of the act, in the tide water of the Schuylkill and the limits of the port of Philadelphia, but was brought down the river by a freshet. It had no owner, master, or agent having charge of it, but had been abandoned in the upper waters of the river."

We find nothing whatever in the opinion of the supreme court of Pennsylvania to indicate that that court disapproved of the construction which the district court of Philadelphia had given to the act of 1859.

Clearly the obstruction caused by the wreck of the steamer *Maryland* was one within the letter and the spirit of the act of 1859. The steamer sank in the channel way of the tide water of the river Schuylkill within the limits of the port of Philadelphia. The wreck was of considerable value and had a responsible owner, who had charge of it. We cannot doubt that, under the state law, the duty of having the wreck raised and removed was upon the master warden of the port, a state officer, and not upon the city of Philadelphia; and, if there was any neglect in respect to the wreck, it was the neglect of the master warden, for whose negligence the city is not answerable.

As well on the ground upon which the district judge placed his decision, as for the other reasons stated in this opinion, the decree of the court below is affirmed.

SCHOENEMANN v. UNITED STATES.

(Circuit Court of Appeals, Third Circuit. January 15, 1903.)

No. 11.

1. CUSTOMS DUTIES—CLASSIFICATION—SHELLS.

Shells which have been treated with chloride of lime and washed with water to cleanse them from animal or vegetable matter are entitled to free entry under paragraph 635 of the free list in the tariff act of 1897 [U. S. Comp. St. 1901, p. 1686], which includes "shells not sawed, cut, polished or otherwise manufactured, or advanced in value from the natural state." While the cleansing may add slightly to their value, they cannot be said to have been advanced in value from their natural state so as to exclude them from such paragraph.

Appeal from the Circuit Court of the United States for the Eastern District of Pennsylvania.

For opinion below, see 115 Fed. 842.

Frank P. Prichard, for appellant.

James B. Holland and Wm. M. Stewart, Jr., for the United States.

Before ACHESON, DALLAS, and GRAY, Circuit Judges.

GRAY, Circuit Judge. The appellant, William C. Schoenemann, imported into the port of Philadelphia, in September, 1897, merchandise consisting of shells. The marine animal had been taken from the shells and the shells themselves cleansed, by being put into a tub with chloride of lime and then washed with clean water, in order to remove all animal matter, dirt, and offensive smell. The importer claimed that these shells were free from duty, under paragraph 635, part of the free list of the tariff act of 1897 [U. S. Comp. St. 1901, p. 1686], which reads as follows:

"Pearl, mother of, and shells, not sawed, cut, polished or otherwise manufactured, or advanced in value from the natural state."

The collector of the port, who was afterwards sustained by the United States board of general appraisers, assessed the duty upon the shells at 35 per cent. ad valorem, under paragraph 450 of the tariff act of 1897 [U. S. Comp. St. 1901, p. 1678], which reads as follows:

"Manufactures of leather, finished or unfinished, manufactures of fur, gelatin, gutta-percha, human hair, ivory, vegetable ivory, mother of pearl and shell, plaster of paris, papier mache and vulcanized india rubber, known as 'hard rubber,' or of which these substances or either of them is the component material of chief value, not specially provided for in this act, and shells engraved, cut, ornamented, or otherwise manufactured, thirty-five per cent. ad valorem."

The grounds for this classification and imposition of duty, as stated by the board of general appraisers, were that although it appeared from the evidence that the articles had not been "engraved, cut, ornamented, or otherwise manufactured," the cleansing process had advanced the articles in value from their natural state to the extent of about 10 per cent. ad valorem, and that therefore, inasmuch as the shells had been materially advanced in value from what was called the "natural state," by the process of cleansing, they were excluded from the provisions of said paragraph 635 of the free list [U. S.

Comp. St. 1901, p. 1686], by the language used therein. The appraisers then proceed to justify the classification made by the collector, under paragraph 450 of the act [U. S. Comp. St. 1901, p. 1678], as follows:

"If it be admitted that the articles had not been subjected to any manufacturing process, the classification as made by the collector would be, in our opinion, justified by the proper application of the similitude clause, section 7 of the tariff act of 1897 [U. S. Comp. St. 1901, p. 1693], which provides that 'each and every imported article, not enumerated in this act, which is similar, either in material, quality, texture, or the use to which it may be applied to any article enumerated in this act as chargeable with duty, shall pay the same rate of duty which is levied on the enumerated article which it most resembles in any of the particulars before mentioned.' * * * Assuming it is true that the article in question is not specially enumerated in the tariff act, the settled rule is that a nonenumerated article, if found to bear a substantial similitude to an enumerated article, either in material, quality, texture, or the use to which it is applied, is made liable to precisely the same duty as that imposed upon the enumerated article. * * * There is a manifest resemblance between the articles under consideration and the shells described in said paragraph 450 [U. S. Comp. St. 1901, p. 1678], under which the collector made the classification, and this resemblance is not in the material alone, but also in the quality, if not in the use to which the articles were applied. It was not necessary for the collector to have expressly invoked the similitude clause in making the reported classification. It is sufficient if such classification can now be justified under the rules laid down by the courts."

In the proceedings for a review of this decision of the said board of general appraisers, before the circuit court, the learned judge affirmed their decision, and from the decree of that court, this appeal has been taken.

In the decision of the board of appraisers, thus affirmed by the circuit court, we think there was error. It seems to be now admitted that these articles could not be classified under paragraph 450, as "shells engraved, cut, ornamented, or otherwise manufactured," and that the collector was mistaken as to the shells having been cleansed by chemical process, or that an epidermis had been removed, or that they had been polished by such process. The evidence in the record before us shows that they had simply been washed with clean water, after having been left for a few hours in water containing chloride of lime, and clearly they were not "otherwise manufactured." The ground, however, on which the court sustained the classification of the appraisers, is the one stated by them. After stating his opinion that these shells were not embraced within paragraph 635 of the free list [U. S. Comp. St. 1901, p. 1686], the learned judge proceeds as follows:

"I think, however, that the rate of 35% was properly imposed under section 7 [U. S. Comp. St. 1901, p. 1693]. This is the so-called similitude section, and provides, 'That each and every imported article not enumerated in this act, which is similar either in material, quality, texture, or the use to which it may be applied to any article enumerated in this act as chargeable with duty, shall pay the same rate of duty which is levied on the enumerated article which it most resembles in any of the particulars above mentioned.' Paragraph 450 [U. S. Comp. St. 1901, p. 1678] imposes a rate of 35% upon manufactures of shell, and also upon 'shells engraved, cut, ornamented, or otherwise manufactured.' While it is true that the shells in controversy have merely been cleaned, and therefore do not come within the language

just quoted, nevertheless, they come so nearly within it that section 7 [U. S. Comp. St. 1901, p. 1693] carries them the remainder of the way. They are certainly similar in material, in quality, and in texture, to shells engraved, cut, ornamented or otherwise manufactured, and they are also similar in some of the uses to which they may be applied, for it appears in evidence that the shells in controversy are sometimes used as ornaments without being subjected to any further process."

We cannot agree with the learned judge in thinking that this "similar" section is applicable to the case before us. Paragraph 450 [U. S. Comp. St. 1901, p. 1678] imposes a duty on shells "engraved, cut, ornamented, or otherwise manufactured." Admitting that the shells in question are not within this category, they still are shells not "engraved, cut, ornamented, or otherwise manufactured," and to say that such are articles not enumerated in this act, similar either in material, quality, texture or the use to which they may be applied, to shells which are "engraved, cut, ornamented or otherwise manufactured," and so chargeable with the same rate of duty, makes the section in question work an absurdity. It is saying, in effect, that though "shells engraved," for instance, are expressly made subject to a tax of 35 per cent., shells not engraved shall be liable to the same tax, because shells not engraved are similar to "shells engraved." We do not think that this section is susceptible of this interpretation, or was meant to apply except to articles of manufacture, which, though different and distinct from each other, are similar in the respects mentioned in the statute. In this case, there is an identity of material, not similarity, and when the statute expressly prescribes a duty for this material, when it is in a certain condition, it must be taken to preclude the application of the similitude statute to the same material not in that condition. It would be equally as reasonable to say that, because certain stones fashioned into monuments or into cubical blocks are dutiable, stones not so fashioned and not in building shapes, should be liable to the same tax, on the ground of similarity of material.

There is nothing in the record of this case, that suggests an attempted evasion of the tariff laws, against which, the supreme court has said the similitude clause was designed to be a protection. These articles are not manufactured imitations of shells, suitable to take their place in use as ornaments; but they are the very shells mentioned in the act, lacking the changes from the natural state mentioned and described therein, as the conditions prerequisite to their being dutiable. It must be presumed that the lawmaking power had in mind the difference between "shells engraved, cut, ornamented, or otherwise manufactured," and shells that were not so, and did not intend that the very differentiation made by the law itself, should be nullified and made of no effect by this similitude provision. The contention of the court below makes the legislative act futile, and accomplishes the result clearly not intended, to wit, that all shells, in whatever state or condition, shall be dutiable at 35 per cent. ad valorem.

The shells in question, admittedly incapable of classification under paragraph 450 [U. S. Comp. St. 1901, p. 1678], and not coming within the purview of "the similar" provisions of section 7 [U. S. Comp. St. 1901, p. 1693], it remains to consider whether they should

be classified under paragraph 635 of the free list [U. S. Comp. St. 1901, p. 1686]. In this paragraph are included "shells not sawed, cut, polished, or otherwise manufactured, or advanced in value from the natural state." There is no controversy as to the meaning of the words "not sawed, cut, polished, or otherwise manufactured," or that, if those words stood alone, the shells in question would be admitted free of duty. It is, however, contended that the shells had been "advanced in value from the natural state," within the meaning of those words in the paragraph referred to, and that therefore they are excluded from the free list. We do not think, however, that the cleansing of these shells, in the manner disclosed by the evidence and already discussed, though adding slightly to their value, effected a change in them "from the natural state." Seashells are the hard, organized substances forming the exterior covering and protection of certain marine animals, and these hard bony coverings are not changed from their natural state, by having these animals and the adventitious and foreign matter clinging to them removed. They are no part of the shell, and the natural state of the shell remains after this removal takes place. It would be as reasonable to say that the natural state of the shell existed only when the marine animal, which it contained and protected, was present, as to say that there was a change from the natural state, wrought by cleansing it from foreign substances which were no part of it. Furthermore, we think that the words "or advanced in value from the natural state," must be read with "or otherwise manufactured," not disjunctively, but so as to join the general concept of the latter phrase with that of the former.

In this, as in all other such cases, we must bear in mind the rule laid down in *Hartranft v. Wiegmann*, 121 U. S. 609, 7 Sup. Ct. 1240, 30 L. Ed. 1012, where the court say:

"But, if the question were one of doubt, the doubt would be resolved in favor of the importer, as duties are never imposed upon the citizen upon vague or doubtful interpretation."

For these reasons, we think that the shells in question should have been classified under paragraph 635 of the free list [U. S. Comp. St. 1901, p. 1686]. Without quoting from them, we refer to the cases cited by the appellant, as supporting and illustrating the conclusions at which we have arrived. *U. S. v. Merck*, 13 C. C. A. 432, 66 Fed. 251; *U. S. v. Godwin* (C. C.) 91 Fed. 753; *U. S. v. Richards* (C. C.) 99 Fed. 262; *Frazee v. Moffitt* (C. C.) 18 Fed. 584. It is unnecessary, therefore, to resort to section 6 [U. S. Comp. St. 1693], imposing a tax upon the importation of raw or unmanufactured articles not enumerated or provided for in the act.

The decree of the court below is therefore reversed. Let a decree be drawn in conformity with this opinion.

SLAUGHTER et al. v. LA COMPAGNIE FRANCOISES DES CABLES
TELEGRAPHIQUES.

(Circuit Court of Appeals, Second Circuit. December 2, 1902.)

No. 28.

1. CONTRACTS—BREACH—ELECTION OF REMEDIES.

A party to a contract, who has brought an action at law for its breach, and prosecuted the same to a judgment for damages, cannot thereafter maintain a suit in equity to enforce specific performance.

Appeal from the Circuit Court of the United States for the Southern District of New York.

This cause comes here upon appeal from a decree of the circuit court, Southern district of New York (113 Fed. 21), sustaining a demurrer to the bill, and dismissing same, with costs.

Adalter Artz, for appellants.

Edw. K. Jones, for appellee.

Before WALLACE, LACOMBE, and TOWNSEND, Circuit Judges.

LACOMBE, Circuit Judge. The bill sets forth a written contract between the parties, by the terms of which defendant agreed to execute a lease for 99 years to complainants of certain cable lines and franchises upon complainants' fulfillment of certain conditions,—notably, the beginning work on certain repairs within 45 days, and prosecuting the same to the extent of \$10,000. It is expressly provided in the contract that it shall be null and void unless, within 45 days from its execution, complainants should commence the work of repairs, and within the same period pay to defendant any sum expended or agreed to be expended in the repairs in the contract contemplated, not to exceed \$5,000. The bill alleges that within the 45 days complainants tendered \$10,000 to the defendant, but does not aver that they commenced the work of repairs within the same period; that thereupon defendant refused to accept the \$10,000, or to carry out the terms of the contract, viz., to execute the lease. Wherefore specific performance is prayed. The bill further avers that heretofore complainants brought in this court a common-law action for damages for the breach of the same contract, specific performance of which is now prayed; that said action proceeded to trial and judgment upon a verdict sustaining the validity of said contract, and "awarding the plaintiff, by direction of the court, nominal damages, said court having held that no substantial damages for breach of said contract could be assessed at law."

The circuit court, in deciding the demurrer, held that, in view of the judgment between the parties in the common-law action, the question was no longer open whether the failure both to pay (or tender) and to begin work within the 45 days avoided the contract. The more serious difficulty with complainant's claim, however, is that he not only elected to sue at law for breach of the contract, but actually prosecuted that suit to final judgment in damages. One cannot have damages

¶ 1. See Election of Remedies, vol. 18, Cent. Dig. § 17.

for the breach of a contract, and a decree also for its specific performance. Not because the remedies are inconsistent. On the contrary, they are alternative. Both are in affirmance of the contract, and, indeed, remedy in both forms might be sought in one and the same action. *Connihan v. Thompson*, 111 Mass. 270. The beginning, therefore, of an action at law for damages, or of a suit in equity for specific performance, does not operate as a decisive act, which determines the rights of the parties once for all. But if the plaintiff institute separate actions, he cannot carry both to judgment and satisfaction, and may be compelled by order of the court, at any stage of the proceedings, to elect which he will further prosecute. *Rogers v. Vosburgh*, 4 Johns. Ch. 84; *Livingston v. Kane*, 3 Johns. Ch. 224. In *Fox v. Scard*, 33 Beav. 327, defendant had contracted not to carry on the business of surgeon at a particular place for a certain period of time, and had executed a bond in the penal sum of £1,000, conditioned to the same effect. It was held that a recovery of damages at law would bar his prosecution of a suit in equity for an injunction. To the same effect is *Sainter v. Ferguson*, 1 Macn. & G. 286. Defendant here relies on a dictum in *Fox v. Scard* referring to former practice in equity, where the legal right was in doubt, under which the court used to direct an action to try the right. If plaintiff merely established his right, and took nominal damages, he obtained equitable relief; but, if he sought and obtained substantial damages, the court, when he came back, dismissed his bill, saying, "You have already had your remedy at law." But the case at bar is not parallel. Plaintiff has not been directed or allowed by a court of equity to try the single issue of legal right in a court of law. In his action at law he sought for damages,—actual not nominal damages. Modern practice does not allow a party to bring an action at law, not for damages, but to establish some single issues in the controversy, such as validity of contract, breach of it, or what not, and then, having determined those issues in one action, to bring a second action for the relief appropriate to the facts found in the first one. If he sues at law for a breach, he is entitled to recover the damages he has sustained by such breach; and recovering them, whether their amount be large or small, bars him from insisting thereafter in equity that defendant perform the contract. If, as the trial of the action at law progresses, plaintiff discovers that the evidence is not likely to secure him sufficient damages, he should apply to withdraw a juror, so as to leave himself free to apply thereafter for equitable relief. In the cause at bar he was warned by the ruling of the trial judge, before it was sent to the jury, that he could not expect substantial damages. When after that he persisted in going on to verdict and judgment, he made an election which he cannot now repudiate.

Some weight is sought to be laid on the language attributed to the trial judge in the averments of the complaint as to the disposition of the action at law,—that the court held "that no substantial damages for breach of said contract could be assessed at law." Certainly the court did not hold, as a general principle, that, for the breach of a contract to lease personal property, substantial damages could not be assessed in an action at law. Nor does the language above quoted im-

port that any such ruling was made. The broadest permissible construction is that the court held that, in the particular case presented to it, when both sides rested, and the proofs were closed, no substantial damages for breach of contract could be assessed by the jury. That result not infrequently happens when there has been a failure to marshal evidence sufficient to give the jury some basis of arriving at a conclusion which they can fairly express in figures. If such failure result from plaintiff's neglect to gather available proof, it is his fault; if it result because such proof is not to be had, it is his misfortune; but if, because of such failure, he reaches the conclusion that he can better his condition by seeking equitable relief, it behooves him to make his election and terminate his action for damages before it goes to verdict and judgment.

The decree of the circuit court is affirmed, with costs.

DUNTON v. ALLAN S. S. CO., Limited.

(Circuit Court of Appeals, Third Circuit. January 15, 1903.)

No. 7.

1. COLLISION—STEAM AND SAILING VESSELS MEETING IN FOG—UNAVOIDABLE ACCIDENT.

A collision occurred at sea during a thick fog, between a schooner and a steamship, which met on nearly parallel courses. On hearing the fog signal of the schooner the steamer, which was then quite close, at once slowed down and proceeded with caution, while the schooner, which was sailing close-hauled on the port tack, with a very light breeze, kept her course and speed. The vessels were both properly manned and equipped, and had proper lookouts. After they sighted each other, when they were about 100 yards apart, the steamer did all that was possible to prevent collision. *Held*, that neither vessel was chargeable with any fault, and that the collision must be attributed to unavoidable accident.

Appeal from the District Court of the United States for the Eastern District of Pennsylvania.

For opinion below, see 115 Fed. 250.

Robert H. Smith, for appellant.

Henry R. Edmunds, for appellee.

Before ACHESON, DALLAS, and GRAY, Circuit Judges.

GRAY, Circuit Judge. The statement of facts made by appellant, so far as borne out by the record, are as follows:

The collision, out of which this suit grows, was between the fore-masted schooner "Lydia M. Deering," of which the appellant was the master, and the British steamship "Siberian," owned by the Allan Steamship Company, Limited, the appellee. It took place about 6:20 p. m. on June 2, 1901, the schooner at the time being bound from the Kennebec river, Me., to Washington, D. C., with a cargo of ice, and the steamship bound from Philadelphia to Glasgow, via St. Johns, Newfoundland, with a general cargo. The place of the collision was about 75 miles east from the Capes of the Delaware. The weather was very foggy at the time and place of the collision, and had been

more or less foggy all the day. The wind was very light from the south southwest. The schooner was carrying all her sails, except the jib topsail; was close-hauled by the wind on the port tack and was making about two knots an hour. The bluff of the steamship's port bow struck the schooner a glancing blow on the port side, near the mizzen rigging, doing considerable damage, but temporary repairs were made by her master and crew, and she proceeded to her destination, where she discharged her cargo, and then was towed to Baltimore and the collision damages repaired.

The witnesses on both sides agree that there was a thick fog at the time of the collision, as well as for some hours previous thereto. They also agree that the wind was light, and barely enough to give steerage way to the schooner. There is some difference in the testimony of those on the schooner and those on the steamship, as to the distance at which an object could be seen through the fog. There is no difference in the testimony as to the direction of the wind, and that the schooner, close-hauled on the port tack, was heading nearly west, and that the steamer bound from Philadelphia to Glasgow, heading somewhere about east by north, was in a course that would cross that of the schooner at about a point or a point and a half.

There is no real conflict in the testimony, but there is an important difference between the testimony of those on the schooner and those on the steamer, as to how long the signals of the other were heard prior to the collision. It is testified in behalf of the schooner, that she was equipped with a patent mechanical fog horn, which was being worked by a man stationed for that purpose, and that a signal of two blasts on this horn was blown at intervals of less than a minute, and had been so blown for several hours before the collision. The man stationed for this purpose did not testify, it being stated by the libellant that he had left the schooner and was sick in a hospital. The testimony of those on the steamer is, that an automatic steam fog whistle was blown at the required intervals of a minute or less during the fog, and up to the time of the collision. In fact, the case of libellant largely rests on the fact, testified to by those on the schooner, that the whistle of the steamer was heard at least 15 minutes before the collision, and on the contention thereupon made, that the fog horn of the schooner could have been heard on the steamer for a much longer interval than was testified to. The testimony of the navigating officers and the engineer of the steamer, on this point, is that some half hour or more before the collision, owing to the fog, a signal was given to the engineer of the steamer for, what is called, "half speed and stand by," and that about 20 minutes before the collision, the signal was given for "slow and stand by." There is no suggestion in the testimony that the steamer was not well officered and manned, or that the officers were negligent or inattentive in navigating the ship. Their testimony is, that some time before the collision, the master and first and second officers were on the bridge; that the first signal, which was one of two blasts, heard from the schooner, was just a few seconds before she loomed in sight through the fog; that immediately upon hearing these whistles, a signal was given to the engineer to stop, and within a few seconds thereafter, when the schooner loomed up, another signal

for "full speed astern" was given, and that almost immediately thereafter, the collision occurred. The schooner held her course, in obedience to the ordinary rule in that behalf, but it may well be doubted whether, in such conditions as then prevailed, with the whistle of a steamer sounding from a point to a point and a half on her port bow, she should not have parted her helm and thus steered clear of the course of the oncoming vessel. The libelant contends that the steamer was going at too high a speed, and that the signals from the schooner either were or should have been heard as soon as the steamer's signals were heard on the libelant's vessel. But those on board the steamer must be taken to know what occurred there, in the absence of any direct or collateral impeachment of their testimony. It is to be remembered, too, that the breeze was blowing from the steamer towards the schooner, and that the steamer's whistle was probably more powerful than the horn on the schooner.

A careful review of the testimony convinces us that, on both vessels, the requisite care, under the circumstances, was taken to avoid accident, and that the collision was an unavoidable accident, for which no fault should be imputed to either vessel. In this, we agree with the opinion of the learned judge of the court below, when he says:

"The testimony satisfies me that, as soon as the vessels came in sight of each other, everything that was possible was done upon the steamship to avert the threatened disaster. She had already slowed down upon hearing for the first time the fog signal from the schooner, and this, I think, was her full duty. As the supreme court of the United States has said in *The Holberg*, 157 U. S. 68, 15 Sup. Ct. 480, 39 L. Ed. 620: 'No case has ever held that a steamer was obliged to stop at the first signal heard by her, unless its proximity be such as to indicate immediate danger.' Clearly there was no such indication in the present case, and the steamship was not at fault, therefore, in doing no more than slowing down to a moderate speed, and thereafter proceeding with caution. As soon as the *Siberian* saw the schooner, she immediately had her engines put full speed astern, and put her helm astarboard in the effort to pass in safety. The schooner held her course, and in this I am unable to say that she was in error; for, if it be true, as was testified by some of the witnesses for the steamship, that the schooner's helm was put to port, the result would probably have been what those witnesses say that it actually was, namely: to swing the schooner's stern to port, and thereby bring her more directly across the bow of the approaching steamship. The bluff of the *Siberian*'s port bow struck the schooner's port quarter well aft, and did a good deal of damage. Neither vessel, I think, was moving through the fog at a negligent rate of speed. The schooner's sails were all drawing, but the wind was so light that, as I have already said, she was not moving faster than two knots an hour, which gave her little more than steerage way; and the steamship had slowed her speed at the first intimation of danger, and thereafter proceeded with due caution."

And we agree with the court below in thinking that the libel should be dismissed, leaving each party to bear his own costs.

Let a decree be so drawn.

SALEM IRON CO. v. COMMONWEALTH IRON CO.

(Circuit Court of Appeals, Third Circuit. January 5, 1903.)

No. 41.

1. INSTRUCTIONS—REQUESTS—FEDERAL PRACTICE.

In the federal courts a trial judge is not required to specifically and directly answer every point which may be submitted by counsel. If the instructions given; as a whole, fully, correctly, and clearly present the law, nothing further can be required.

2. CORPORATIONS—RATIFICATION OF CONTRACT—EVIDENCE.

Evidence that a contract made on behalf of a corporation by its officers was not objected to by the directors, even if not sufficient, under the circumstances shown, to prove ratification, is admissible on that issue where the corporation subsequently seeks to repudiate the contract.

In Error to the Circuit Court of the United States for the Western District of Pennsylvania.

N. B. Billingsley, for plaintiff in error.

Harvey D. Goulder and Wm. Scott, for defendant in error.

Before ACHESON, DALLAS, and GRAY, Circuit Judges.

DALLAS, Circuit Judge. In the courts of the United States, whatever may be the rule in other jurisdictions, a trial judge is not obliged to specifically and directly answer every point which may be submitted by counsel. *Improvement Co. v. Stead*, 95 U. S. 166, 24 L. Ed. 403; *Insurance Co. v. Ward*, 140 U. S. 76, 11 Sup. Ct. 720, 35 L. Ed. 371; *Railroad Co. v. O'Brien*, 16 C. C. A. 216, 69 Fed. 223. If the court's instructions, as a whole, fully, correctly, and clearly present the law, nothing more can be required; and careful examination of all that was said by the learned judge in this case has entirely satisfied us that he explained the whole law applicable to it, in precise conformity with our decision, made about a year ago, in the similar case of *Salem Iron Co. v. Lake Superior Consol. Iron Mines*, 50 C. C. A. 213, 112 Fed. 239. We have not been convinced that that decision was, upon any point, erroneous, and nothing need now be added to what was then said.

No error was committed in admitting the testimony that the contract in suit had not been objected to. Nonobjection may not, under the circumstances, have been equivalent to ratification; but, taken in connection with the other facts of which there was evidence, it was properly for consideration upon the question of ratification, which, with proper instructions, was rightly submitted to the jury.

What has been said renders it unnecessary to refer to the specifications with particularity. None of them is, in our opinion, well founded, and therefore the judgment of the circuit court is affirmed.

FARMERS' MFG. CO. v. SPRUKS MFG. CO. et al.

(Circuit Court, E. D. North Carolina. December 23, 1902.)

1 PATENTS—INFRINGEMENT—INDIVIDUAL LIABILITY OF OFFICERS OF CORPORATIONS.

Officers of a corporation are not liable in equity for infringement of a patent by the corporation where they are not charged with having participated in the infringement otherwise than as officers of the corporation.

2 SAME—DETERMINING VALIDITY—MATTERS OF COMMON KNOWLEDGE.

In determining the novelty of a patented device, the court will take judicial notice of matters of common knowledge relating to the state of the prior art.

3 SAME—VALIDITY—INVENTION

Patents are valid only when granted for a mechanically novel structure which involves invention, and not merely for an old thing in a better shape or of better material, or having its utility due to mechanical skill in adopting what was old.

4 SAME—PATENTABLE NOVELTY—VENTILATING BARRELS.

The East patent, No. 420,021, for a ventilating barrel made of a sheet of veneer provided with parallel slits arranged lengthwise the barrel, and terminating at a distance from the ends, leaving the edges of the veneer sheet integral, is void for lack of patentable novelty in view of the prior art which showed both barrels made of veneer sheets and bilged, and barrels and baskets having ventilating holes and slits in the sides. Claims 1 and 3 also construed, and *held* not infringed, even if conceded validity.

In Equity. Suit for infringement of letters patent, No. 420,021, for a ventilating barrel, granted to John F. East May 27, 1890. On final hearing.

E. T. Fenwick, S. C. Bragaw, and A. D. Ward, for complainant.

H. T. Fenton and W. B. Rodman, for defendants.

PURNELL, District Judge. Complainant filed a bill in equity as assignee of John F. East, on letters patent No. 420,021, May 27, 1890, for alleged improvement in ventilating barrels. The corporation defendant and its officers are jointly and severally charged with infringement by the manufacture and sale of barrels alleged to be substantially similar to the patented barrel. The answers filed by those defendants served with process set up the usual defenses in patent cases, but the proofs were directed to two issues only: (1) That the patent is invalid for want of novelty in the thing patented, if the claims are construed as the complainant contends; and (2) noninfringement, under any proper construction of the claims of the patent. Although complainant's patent contains four claims, it is alleged to be infringed by defendants' device only as to claims numbered 1 and 3, it being conceded that claims numbered 2 and 4 contain limitations which exclude defendants' device.

Claims 1 and 3 alleged to be infringed are as follows:

"No. 1. A barrel or receptacle having its sides composed of a sheet of veneer provided with parallel slits arranged lengthwise the barrel and terminating at a distance from the edges of the sheet and leaving the edges of the veneer sheet continuous or integral, as shown and described."

"No. 3. A barrel or receptacle having its sides composed of a sheet of veneer provided with parallel slits arranged lengthwise the barrel and terminating at a distance from the edges of the sheet and expanded in the middle to a greater diameter than at the ends, substantially as shown and described."

The defendant Geo. T. Leach, president of defendant corporation, answering the bill, denies that he has done or committed any act or thing in respect to the matter recited in the bill or alleged to have infringed any rights of the complainant in his individual capacity, and has not on his individual account made, used, or sold any ventilating barrels or co-operated with or acted for the said corporation codefendant in making, using, or selling any such barrel, except as an officer of said corporation, and that he is advised that the bill is defective and insufficient for lack of averment in charging him with the commission of any act, matter, or thing in his individual capacity. The objection of this defendant is sustained. As to him and the other defendants in their individual capacity, it is adjudged and decreed that the bill be dismissed. If it was intended in the bill to charge a conspiracy by the individual defendants served, the remedy would be at law, and not in equity. *Ambler v. Choteau*, 107 U. S. 556, 1 Sup. Ct. 556, 27 L. Ed. 322; *Bowers v. Atlantic, Gulf & Pac. Co.* (C. C.) 104 Fed. 887.

This narrows the inquiry to the contention between complainant and the Spruks Manufacturing Company, defendant, on the merits of the bill. The first inquiry which naturally presents itself is, for what novelty or device was the complainant granted letters patent? The letters patent, it is admitted, have not been adjudicated, hence the state of the art and the novelty of the device or claim is necessarily involved, and this question is expressly raised by the issues on the pleadings as well as in the argument. In considering questions of this nature, a court will not shut its eyes to what may be termed common knowledge, but will take judicial notice of such matters without proof. *Slawson v. Railroad Co.*, 107 U. S. 649, 2 Sup. Ct. 663, 27 L. Ed. 576; *Phillips v. City of Detroit*, 111 U. S. 604, 4 Sup. Ct. 580, 28 L. Ed. 532; *Glue Co. v. Upton*, 97 U. S. 3, 24 L. Ed. 985. The idea of a barrel is not new, nor is that of a ventilating barrel. The ordinary barrel with holes hacked in the staves for ventilation in shipping fruits, vegetables, and such articles of commerce which contain moisture, was used years prior to the East patent. The same may be said of veneering or thin sheets of wood veneer. This is not only common knowledge, but is proved in the record and admitted by all parties,—which is unnecessary.

In 1861, S. Roberts obtained letters patent, re-issued in 1874, No. 6,044, for a barrel made of a sheet of wood veneering, in which it is said the "invention relates to the formation of a barrel from volute sheets," etc. Roberts, it is claimed, is the first person to have made a barrel with a sheet of wood veneering. At all events, he did so, and obtained letters patent long prior to complainant's device. In 1887, letters patent, No. 7,289, were granted to E. B. Georgia for a stave barrel, with a bilge or curve having parallel slots cut longitudinally in the periphery, and not extending to the chine ends, for

the purpose of ventilation in the shipment of perishable goods, fruits, vegetables, etc.

In 1889, letters patent, No. 417,218, were issued to Henry C. Bailey for a wooden mat, described in the specifications as consisting of "wooden mats and similar articles from wooden blanks." This patent shows that slitted wood veneer sheets, with the slits held open, were used to make mats and other articles prior to complainant's invention.

The Cook patent, 1859, No. 24,723, and the Mabbett patent, 1868, No. 73,352,—the former for ventilated fruit baskets and the latter for berry boxes,—show the prior use of the idea of a receptacle of thin wood, slotted for ventilation. It will be seen from an examination of these patents that barrels made of a thin sheet of veneer, bilged or curved barrels made of a single sheet of veneer, barrels formed primarily in cylindrical form from a single sheet of veneer, and then given a bilge or curve by slotting the edges of the blank and contracting the ends; that ventilating barrels formed by a double series of parallel slots extending from near the center, and not out to the edge or chine end; that circular shaped berry baskets with ventilating slots; and that flaring baskets with wood strips, slotted and with terminal holes, expanded and held open by inside and outside bands,—were in use, constituting the state of the art, and not novel, such as should have entitled any one to letters patent for either in 1890, the date of the East patent, upon which complainant by assignment bases its suit.

A patent is a monopoly, generally denominated, the consideration for which is the disclosure by the patentee of something not then within the domain of public knowledge, or the ability of mechanical skill of persons in the art having personal knowledge of anything which was then old, to produce as the result of such mechanical skill, when called upon to do so by the necessity of the trade. *Dunbar v. Meyers*, 94 U. S. 187, 24 L. Ed. 34; *Hollister v. Manufacturing Co.*, 113 U. S. 59, 5 Sup. Ct. 717, 28 L. Ed. 901; *Thompson v. Boisselier*, 114 U. S. 1, 5 Sup. Ct. 1042, 29 L. Ed. 76; *Mast, Foos & Co. v. Stover Mfg. Co.*, 177 U. S. 485, 20 Sup. Ct. 708, 44 L. Ed. 856. Patents are valid only when granted for a mechanical novel structure which involves invention, and not merely an old thing in a better shape or of better material, or having its utility due to mechanical skill in adapting what was old. *Gardner v. Herz*, 118 U. S. 180, 6 Sup. Ct. 1027, 30 L. Ed. 158.

Tested by these and authorities of like trend, the East patent, when analyzed by reference to the patent itself and the claims thereunder, its scope, determined by the actual application of the invention claimed by the patentee, did not, in view of the extensive, prior art knowledge, involve anything more than ordinary mechanical skill,—a making by machinery instead of by hand, hence in a more marketable form at less cost, of what was then well known, and is anticipated under the rules in such cases. *Smith v. Nichols*, 21 Wall. 112, 22 L. Ed. 566. Possibly the end to be accomplished,—producing by machinery instead of by hand, at a less cost, and in a more marketable form,—

might entitle complainant to letters patent on the machine, or mechanical invention. But not the product. This, however, the court is not now attempting to decide.

For the reasons stated the court is, therefore, constrained to adjudge the East patent, No. 420,021, invalid.

But for a full determination of the cause, and admitting, for this purpose only, the validity of complainant's patent, or the East patent assigned to complainant, the court further finds, as a fact and conclusion of law, the said letters patent have not been infringed by defendant corporation, the Spruks Manufacturing Company. The defendants' barrel (Canfield barrel, February 1, 1901) is made from a sheet of veneer. The latter is cut to form two barrels, the central dividing line showing the line of cutting the sheet into two parts, from which two barrels are made. The blank for each barrel is a flat sheet having at each end a series of gores of V-shaped openings or slots, and intermediate the opposite gores, between the end hoops and the center bilge, a series of parallel cuts, partially through the wood. Barrels having a series of longitudinally arranged slots provided as ventilating openings were old (Roberts' patent). It is evident that both complainant and defendants have each merely improved upon the prior art; that neither is the originator of the three basic principles involved in each,—ventilating openings, a veneer barrel, and a bilged or curved veneer barrel. In such case, "if the advance towards the thing desired is gradual, and proceeds step by step so no one can claim the complete whole, then each is entitled only to the specific form of device which he has produced." *Railroad Co. v. Sayles*, 97 U. S. 554, 24 L. Ed. 1053.

The complainant's patentee, East, was not the first to make a ventilating barrel, nor was he the first to make a veneer barrel, or the first to make a bilged veneer barrel. In view of which, the fact that defendants' barrel is a ventilating barrel, that it is a veneer barrel, and that it is a bilge veneer barrel, does not determine or aid in determining its identity with complainant's barrel. That both are designed to effect the same purpose is not of importance in such inquiry. Results are not patentable, only the means to effect results. *Case v. Brown*, 2 Wall. 320, 17 L. Ed. 817; *Corning v. Burden*, 15 How. 252, 14 L. Ed. 683. Complainant and defendants started with the disclosures of the Georgia and Roberts patents as the foundation of their respective devices. With the early Georgia patent before a cooper or barrel maker, it certainly did not involve invention to cut a series of parallel ventilating slots or slits in the periphery of the Roberts bilged veneer barrel, more especially as that had been common with stave barrels. But East did not so alter the Roberts barrel, but, starting anew with Roberts' sheet of veneer, and avoiding Roberts' method of making a bilge barrel by contracting the chine ends, he did three things, which differentiate his method and the product of it,—three steps which are sequential, the order of which is essential,—and all so dependent on each other that none may be omitted without destroying or at least failing to obtain the resultant finished product,—the ventilating bilge barrel of veneer de-

scribed in the patent. Instead of cutting out edge gores as Roberts did, East substituted parallel slits or cuts arranged transversely to the length of the blank (parallel with the finished barrel), and extending only through the middle portion of the blank, uncut and continuous or integral, for the purpose of forming the chine ends of the barrel. Following Roberts, he rolled the sheets in cylindrical form and bilged or curved it, not, as Roberts did, by slotting or goring the end edges contracting the cylinder at the ends and bilging it at the center by surface slits, not through, thus causing ventilating spaces. In short, defendants obtained ventilation by means of the slotted ends, and complainant through the expanded center slits. But having taken these two steps, he, East, had a radical series of bent bows or staves, connected at the top and bottom, and under powerful tension, creating a natural and continuing tendency to split the opened slits out to the end; hence he supplied an absolutely essential means to prevent this splitting, by fixedly holding the barrel in the bilged or curved form which such middle expansion gave it, these holding means being "hoops placed inside the barrel to hold the sides of the barrel to its expanded form." And thus he accomplished what complainant now makes and sells, i. e., a ventilating veneer barrel, in which all of these features are required to be present.

Defendants, on the other hand, in the production of their barrel, began with the same Roberts veneer sheet. They preferred Roberts' method of giving the bilge or curve to the barrel, hence gored or notched the end edges, as he did, but cut the gores wider and deeper, so that, after forming a cylinder and when contracting its chine ends (still following Roberts), the widened gore edges would not be brought together, but leave deep ventilating spaces, and put on the usual outside quarter hoops,—and none inside, for none were needed there,—and supplied ventilation near the head or chine ends rather than altogether in the central portion of the barrel. The defendants' barrel is thus shown to be evolved from the Roberts barrel, and not from East's. Defendants widened the end gores or notches by a series of surface cuts on the veneer sheet. Complainant claims these are the slits of his patent. Hence this suit. Aside from the fact that the patented device is in the nature of, and described and claimed as, a combination of old elements, and hence to be compared as an entirety; and aside from the fact that the defendants' device wholly lacks two essential elements of the patented device—middle expansion, and integral chine ends without which it cannot be legally identified with that of the patent. This contention, therefore, cannot be sustained.

The sole other contention of complainant, on which he bases identity of defendants' structure with his, is that defendants' surface cuts, between the outside quarter hoops, are the same as, or the equivalent of, East's "slits."

In the depositions and the argument much expert testimony and learning are devoted to drawing a distinction between slits and slots,—the slots in the Roberts barrel and the slits in the East barrel. Expert testimony is sometimes valuable and frequently interesting, but

seldom controlling,—never when directed to matters capable of ocular demonstration, unscientific matters. That a slot is when a part of the veneer or wood or other material is cut out and removed, and a slit simply when it is cut through, does not require expert testimony or argument to determine. Both are understood as applicable to wood by every hammer and saw carpenter. Neither are per se patentable. Complainant uses a slit as described in the application for the East letters patent for the identical purpose for which Roberts used a slot,—ventilation. But giving to complainant all that is claimed in the argument, defendants do not and have not used for ventilation the slit in complainant's claim or device. Defendants obtain ventilation by means of slots at different places on their barrel from the slits on complainant's barrel, and only use gashes or slits, partially through the veneer, to obtain pliability or bilge. They are not the same, but are they equivalents? It is not controlling if they are, but they are not. "One thing, to be the equivalent of the other, must perform the same function as that other." *Rowell v. Lindsay*, 113 U. S. 103, 5 Sup. Ct. 507, 28 L. Ed. 906. But even this is not conclusive of identity, for "function must be performed in substantially the same way by an alleged equivalent, in order to constitute it such." *Burr v. Duryee*, 1 Wall. 573, 17 L. Ed. 650; *Dryfoos v. Wiese*, 124 U. S. 37, 8 Sup. Ct. 354, 31 L. Ed. 362. An infringement involves substantial identity. The argument used to show infringement assumes every combination of devices in a machine which is used to produce the same effect is necessarily an equivalent for any other combination used for the same purpose.

It is therefore ordered, adjudged, and decreed:

1. That the East patent, No. 420,021, is invalid for the reasons stated.
 2. That there is no infringement of the East patent by defendants.
 3. That the bill herein be dismissed.
 4. That the defendants recover of the complainant their costs and disbursements, to be taxed by the clerk of this court.
- A formal decree will be drawn accordingly.

ALASKA PACKERS' ASS'N v. LETSON et al.

(Circuit Court, D. Washington, N. D. December 16, 1902.)

No. 911.

1. PATENTS—INFRINGEMENT—EQUIVALENTS.

A mechanical equivalent must be adaptable to use as a substitute for something else, and competent to perform the functions of a particular device for which it may be substituted.

2. SAME—CAN-HEADING MACHINES.

The Jensen patent, No. 376,804, for a can crimping and capping machine, covers an invention of such merit and utility as to entitle its claims to a liberal construction. As so construed, claims 5, 9, and 10 are infringed by the machine of the Letson & Burpee patent, No. 629,574; claims 1, 3, and 11 *held* not infringed.

In Equity.

This is a suit in equity, commenced and prosecuted by the Alaska Packers' Association, a corporation, of the state of California, against J. M. K. Letson and F. W. Burpee, a firm engaged in the manufacture of machinery at Fairhaven, in the state of Washington. The complainant sues as the assignee and owner of United States letters patent No. 376,804, issued January 24, 1888, to Mathias Jensen, of Astoria, Or., for a can crimper and capper, a machine which has been extensively used in the business of canning salmon on the Pacific coast since the date of the patent. The bill of complaint charges infringement of said letters patent on the part of the defendants by making and selling without license other machines embodying the invention protected by said patent, and the prayer of the bill is for an injunction to restrain the continuance of such infringement, and for an accounting. This can crimping and capping machine and other inventions of Mathias Jensen have figured extensively during the past 10 years in litigation under the patent laws in the courts of the Ninth circuit, in which Jensen or his assignees were required to defend against similar charges of infringement. At first it was decided that his can crimping and capping machine was an infringement of older patents. See *Norton v. Jensen*, 1 C. C. A. 452, 49 Fed. 859, in which case the circuit court of appeals affirmed the decision of the United States circuit court for the district of Oregon, by Judge Sawyer. The circuit court of appeals, in the case referred to, commended the Jensen machine as being a valuable improvement, and successful in operation; but, giving a broad and liberal construction to one of the patents sued on in that case, which, from the evidence submitted, appeared to be a patent covering an invention of an original or pioneer character for automatically and rapidly placing the caps or end pieces upon can bodies, the court decided the Jensen machine to be an infringer. In cases which were subsequently considered, however, upon additional evidence, the court took a different view of the merits of the Norton inventions, and denied that they were infringed by an improved Jensen machine, built according to the specifications and drawings of United States letters patent No. 443,445. See *Wheaton v. Norton*, 17 C. C. A. 447, 70 Fed. 833; *Norton v. Jensen*, 33 C. C. A. 141, 90 Fed. 415.

Mr. L. W. Seely, one of the witnesses for complainant, gives a perspicuous general description of the Jensen crimping and capping machine, as follows: "The machine shown in the Jensen patent is one for placing heads upon cans, and is intended more particularly for heading cans which have already been filled. Consequently, one of its chief characteristics is that the can enters the machine in a vertical position, and remains in that position while being headed,—this in order to prevent the contents of the can from being spilled. The machine comprises, in the first place, a table, which supports the can-heading mechanism, which I will refer to hereafter. An automatic feeding device is provided, comprising a belt, lettered A in the drawing, which belt has automatically operated spacing mechanism to insure the feeding of only one can at a time. The cans entering the machine upon this belt in a perpendicular position are received by a feeding or transferring device which changes the direction of their motion, and transfers them to the header. When so transferred, each can rests upon a can support or plunger, which is situated in a vertical line with an upper plunger. Between the two plungers is a conical guide or opening, in which the heading takes place. The heads or caps are also automatically fed into the machine, and, when they reach their final destination, are in line with the can, and rest upon movable slides provided with countersinks or ledges which hold them in position. When the parts are in the position I have just stated, the lower can support or plunger is raised, lifting the can, and forcing it through the conical guide, and into the cap as it rests in the countersink. The upper plunger forms a backing or abutment for the cap during the heading operation. As soon as the can is introduced into its head, the slides are withdrawn, and the lower plunger descends, being followed down by the upper plunger, until the can reaches the level at which it entered the header, after which, in its headed form, it is delivered. In the passage of the can to the header it operates a

mechanism which controls the delivery of heads from their feeding device, the can striking a lever, which, through a connected mechanism, withdraws a stop from the can-head feed, and permits one head to be delivered. After the heading of the can in the Jensen machine, it is transferred from there to a crimping device, where the head is secured in place, and is then discharged from the machine."

The answer makes an issue as to the validity of the patent sued upon, but Mr. Wheaton, solicitor for the defendants, in his oral argument upon the hearing of the case fairly admitted the validity of the patent, and its merit as a useful improvement in machinery for automatically putting the head pieces or caps on filled cans, and conceded the invention to be of such degree of merit that the courts would apply a liberal rule in construing the patent to cover the actual combinations specified and claimed and all combinations of equivalent elements. It is also an undisputed fact in the case that the defendants are engaged in manufacturing and furnishing for fish canneries machines for automatically putting the head pieces or caps on cans already filled with fish, doing exactly the same kind of work as the Jensen crimping and capping machine, except crimping the flanges of the can heads, which is a part of the can-heading operation not performed by the alleged infringing machine.

The defendants are the inventors of a can-capping machine described in specifications and drawings in a patent therefor issued to them July 25, 1899, being United States letters patent No. 629,574, and the machines which they are manufacturing and offering for sale are built according to said specifications and drawings with certain modifications and improvements found to be useful since the date of their patent. As I have stated, the defendants' machine is designed to automatically place the caps on filled cans, and does that part of the work in a manner similar to the operation of the Jensen machine. Both machines comprise combinations of similar devices having the same functions, and the principal elements common to both, admitted by the testimony of the defendant Burpee upon his cross-examination, are as follows: There is in both machines a conical guide; that is, a beveled or funnel-shaped hole, which acts to round up and size and guide centrally the can into the can head or cap, which is held in place above the can by a ledge or counter-sunk space above the conical guide. In both machines there is an endless traveling belt, which carries the cans to a second feeding mechanism, which receives them one by one. In both machines similar means are provided for checking the cans in their passage upon the traveling belt, and spacing them so that each can must, with precision, come in contact with the second feeder, designed to move it to the proper position for capping. In both machines the cans are swept off the carrier belt by the second feeder. In both machines the transferring feeders are geared to move continuously when the machine is in operation. In both machines each can in its forward movement, by contact with a device in the nature of a trigger, withdraws temporarily a stop in the path of the can heads so as to admit of but one head at a time being conveyed to the machine. In both machines the can heads are carried automatically in a continuous line until brought in contact with mechanism for placing them one at a time in a position above and in line with the conical guide. In both machines the feeder places the cans one at a time on a rising and falling plunger or can support which moves each can upward into the conical guide. Both machines have, in connection with the conical guide, sliding plates having their inner edges shaped as arcs of a circle, and operate to close up, so as to form a complete circle, and to recede, so as to expand after each can has received its cap, and to admit of the can with the cap upon it being depressed downward and discharged from the conical guide. Both machines have an upper plunger above the cap when in position to receive the can, which rests upon the cap to resist the upward movement of the can, and follows the can downward after it has received its cap; and in both machines each can is automatically carried away from the plunger or can support after being capped.

If the Jensen machine, in its entirety, might be considered as the patented invention, and if another machine doing its work automatically by the opera-

tion of combinations of similar devices amounted to an unlawful infringement entitling the owner of the patent to redress at the hands of the court, the decision of this case would certainly have to be adverse to the defendants. But there is no patent covering the Jensen can crimping and capping machine as an entirety. The patent protects only the particular combinations referred to in each of its several claims, and to convict the defendants of infringement it is necessary for the court to find in the defendants' machine the same combination of devices and elements comprised in one or more of said claims, or equivalents for each element of a combination claimed. In this case it is not asserted that all of the 16 claims of the patent sued on have been infringed by the defendants. According to the evidence and arguments, the controversy relates only to claims numbered 1, 3, 5, 9, 10, and 11, which read as follows:

"(1) An endless traveling carrying belt, a stop, E, extending across it to change the direction of the cans, and arms swinging over the belt, whereby the delivery of the cans from the belt to the feeder is rendered exact, substantially as herein described."

"(3) In combination with a transverse belt, the feeder having the projecting arms between which the cans are received from the belt and the actuating devices by which the motions of the feeder are produced, substantially as herein described."

"(5) The inclined chute into which the caps are placed, and a stop extending across said chute, so as to prevent the caps from moving downward, in combination with a trigger extending across the path of the cans as they are moved toward the capping table, said trigger being connected with the stop, so that as it is moved backward by the passage of the can it withdraws the stop to allow a cap to move down the chute, substantially as herein described."

"(9) The vertically moving plunger upon which the cans are delivered by the feeder, in combination with the conical guide situated above the cans, and the transversely moving slides upon which the caps are received and held, with a mechanism by which the slides are withdrawn as the can enters the cap, substantially as herein described."

"(10) The vertically moving plunger by which the can is raised to receive the cap, and the guide into which the upper end of the can enters the transversely moving cap-holding slides, in combination with the second plunger moving vertically above the cap and following it down by gravitation or otherwise, so as to steady the can in its descent after the cap has been applied, substantially as herein described."

"(11) The vertically moving plunger upon which the can is received, a carrier for placing the can upon the plunger, and a mechanism by which this plunger is reciprocated vertically in combination with a second plunger, which rests upon the top of the cap and steadies it while descending, and a mechanism for raising the second plunger before the arrival of the next cap, substantially as herein described."

Neither of the claims comprise the particular mechanism of the Jensen machine, by which the can heads are transferred from the delivery chute and introduced with rapidity and precision into the countersunk ledge above the conical guide and under the upper plunger.

The subjoined drawings fairly represent the important parts of the two machines. The first sheet is a sectional view taken from a Jensen machine, which was exhibited in operation upon the trial. It is intended especially to show the form, location, and use of the stop-bar, E. The machine from which the drawing was made differs from the specifications in the Jensen patent in this particular: that sprockets and a chain are used to move the cans upon a track in the operation of feeding the cans to the machine in place of the traveling belt described in the specifications. Cuts II, III, and IV are taken from drawings of parts of the Jensen machine by Mr. Monteverde, a witness for the complainant. Cuts V and VII are from drawings of the Letson and Burpee machine, by the same expert witness.

CUT I.

Jensen Machine—Sectional View.

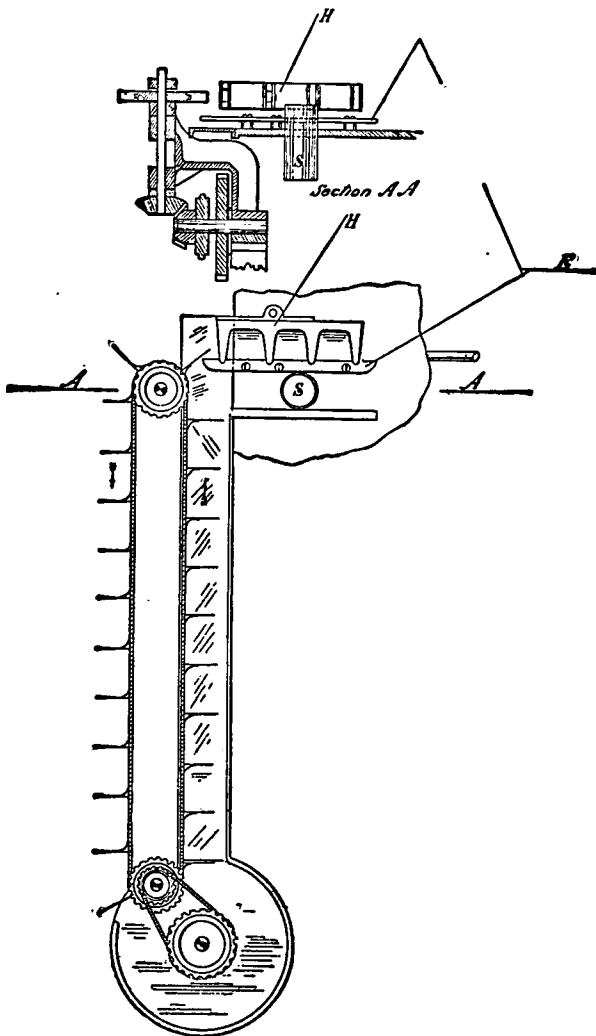

CUT II.
Jensen's Feeder.

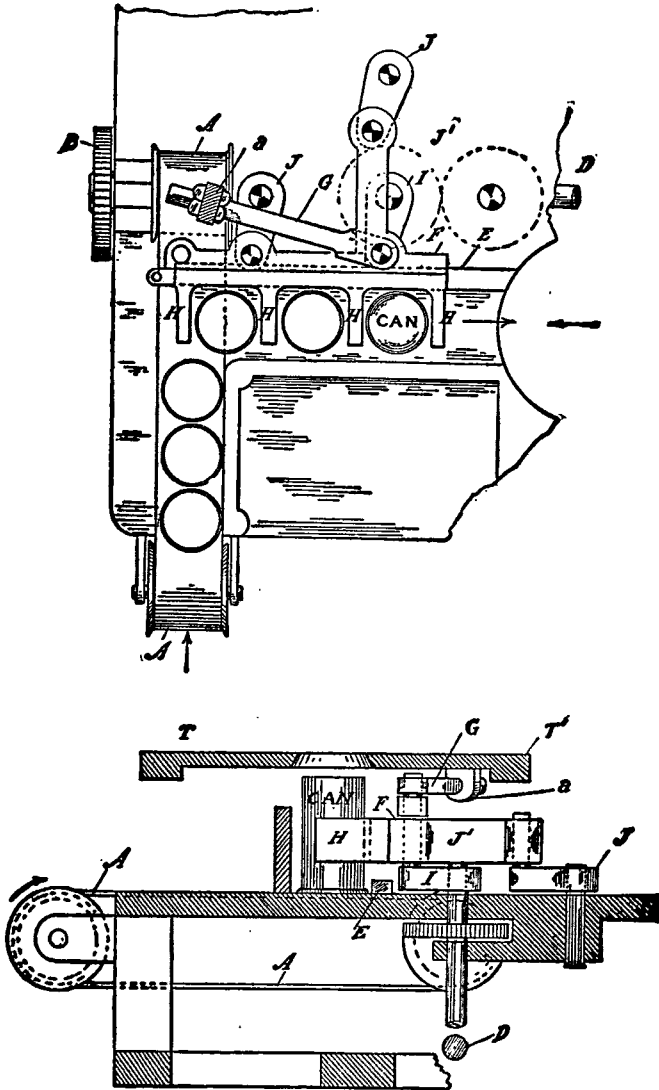

CUT III.

Jensen's Cap-Feeding Mechanism.

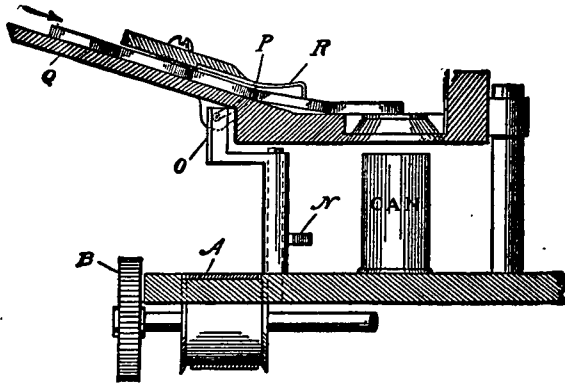
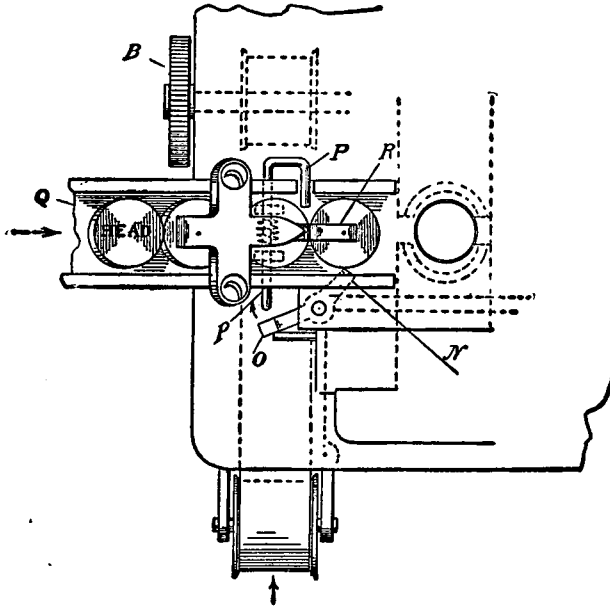

CUT IV.
Jensen's Capping Mechanism.

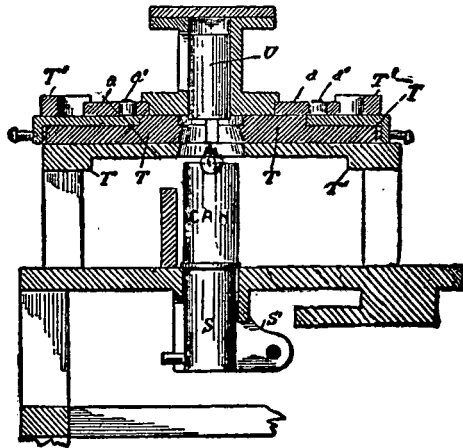
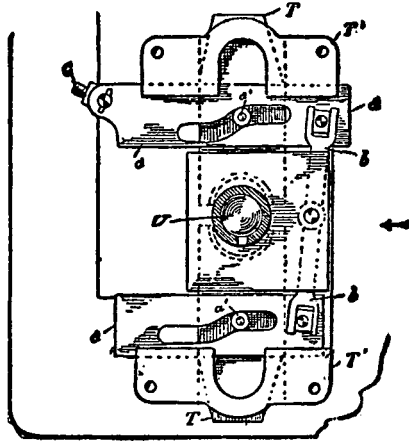

CUT V.

Letson & Burpee's Can-Feeding Mechanism.

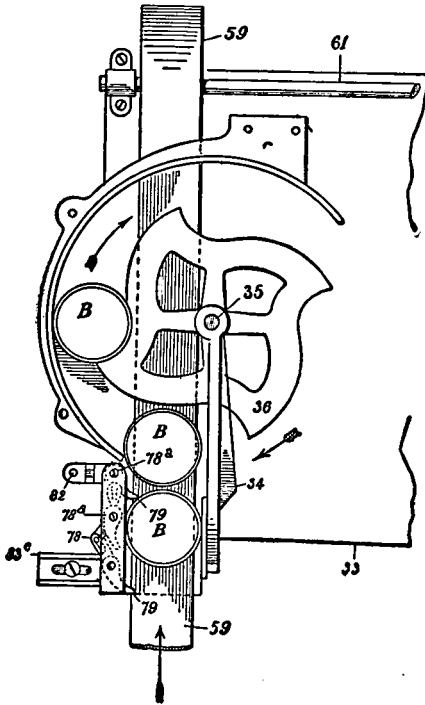

CUT VII.

Letson & Burpee's Can-Capping Mechanism.

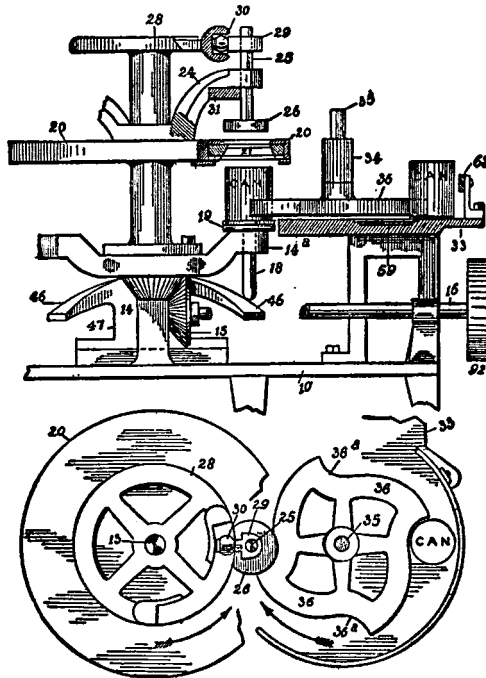

John H. Miller and Dorr & Hadley, for complainant.
Wheaton & Kalloch and Kerr & McCord, for defendants.

HANFORD, District Judge (after stating the facts). I will proceed now to a consideration of the claims in their order, and the question whether either of them has been infringed by the defendants' machine. There are three elements in the first claim, viz., an endless traveling belt, a rigidly fixed stop-bar, and flexible spacing bars swinging over the belt. By this combination of devices the cans are introduced one by one into the heading machine. There is no originality in the devices nor in the combination. The sole merit of the claim consists in the adaptation of the combination to the work of bringing the cans in a vertical position, with the required rapidity and precision, within the influence of the other mechanism which places the caps upon them. In the defendants' machine we find the identical device of a carrying belt performing exactly the same work as the carrying belt in the Jensen machine, and operating in the same way, and flexible spacing bars, which, if not identical in form and mode of operation, certainly have the same office as similar devices in the Jensen machine, and they are so nearly alike in their construction and mode of operation as to be equivalents. Thus we find in the defendants' machine two of the three elements of this combination, but that is all. That the defendants' machine does not contain the stop-bar, E, of the Jensen machine, is admitted; but it is contended that in the operation of the defendants' machine the cans are stopped in their forward movement upon the traveling belt by a device which is equivalent to the bar, E. This contention is stoutly denied by the defendants, and the scientific experts who have testified in behalf of the complainant are, with respect to this point, flatly contradicted by the evidence for the defendants. It will be convenient now to refer to the accompanying drawings illustrating the different parts of the two machines in which the elements of the first claim are designated as follows: A traveling belt, A, the spacing bars by the letters j, j, and the stop-bar by the letter E. In the defendants' machine the traveling belt is numbered 59, the swinging spacing bars 79, and the secondary feeder, which removes the cans from the carrying belt and places them upon the plunger, is numbered 36. This feeder is a wheel, fixed upon a central axis, which rotates in a true circle above the carrying belt, the periphery of which, instead of being circular, is cut away so as to form four concave spaces or pockets, which, as the wheel rotates, partly encircle the cans, sweeping them off the belt upon a curved track slightly inclined, so as to carry them over the belt to the plungers, the cans being kept upon the curved track by a guard, designated 63. The periphery of the wheel, 36, between the four concavities is convex, and the mechanism is so adjusted that each can as it moves upon the belt comes first in contact with the convex portion of the wheel, and according to the testimony in behalf of the complainant the can is stopped in its forward movement when it first strikes the wheel before the concavity operates to change the direction of the can from the direct line of the traveling belt towards the curved track, so that the convex

part of the wheel operates as a stop-bar, performing the same function as the bar, E, in the Jensen machine. This would be true if the periphery, instead of being convex, was cut away to form a straight edge, with an angular shoulder between the point where the can first comes in contact with it and the concavity, or if the speed of the belt in operation was faster than the speed of the wheel, so that the distance which the belt moves before the can commences to move laterally were perceptibly greater than the vacuity between the round can and the swiftly moving convex part of the wheel; but it is my opinion that the evidence, including the exhibit of the defendants' machine in operation upon the hearing, demonstrates that in active operation the can does not make any perceptible stop, but moves continuously, just as a railway train continues onward when its course is changed from a tangent to a curve. The speed of the can is undoubtedly checked, but the rapidly revolving wheel with its curved periphery admits of a continuous onward movement of the round can without halting for any fraction of time whatever. It does not help the case for the complainant to say that the cans are arrested in their forward movement by coming in contact with 36, and kept in position to be caught by its concave pockets, because that effect is not produced by any distinct operation of 36. That member of the organization in the defendants' machine seizes the cans while moving upon the belt, and by one continuous circular movement deflects them from the tangent upon which the belt travels to the curve described by the track and the guard, 63, and places them upon the plungers, and it does not at any time act as a stop. My conclusion is that the stop-bar, E, is an element of claim 1 which is entirely dispensed with in the organization of the defendants' machine, and, being entirely eliminated, infringement of this claim has been avoided.

One element of the combination comprised in claim 3 is the secondary feeder, F, which removes the cans from the carrying belt, and places them upon, and leaves them upon, the plunger, S, which is rigidly fixed in the central part of the machine, but moves vertically with regularity in time to push the cans upward into their caps, and descend after the caps are placed. By reason of its rigid location, S cannot actively assist in removing the cans from the grasp of the feeder, F, which, by its own movements, delivers the cans one at a time upon S, and removes them from it after they are capped. It is my opinion that infringement of this claim has been avoided by not reproducing in defendants' machine this feeder F, or substituting any equivalent for it. Therefore it is unnecessary to comment upon the other elements of claim 3. F is a straight-back with four arms or prongs, designated in the drawings by the letter H, projecting at right angles, so as to form three stalls or pockets. It is attached to three cranks which rotate, giving it an eccentric sweeping movement, which in operation pushes the cans laterally off the belt and longitudinally a step at a time. Each can, when in contact with E, is held stationary with the belt slipping under it, and in that position it first comes in contact with F between the first and second arms, H; that is to say, F, by its sweeping movement, comes against the can, and receives it into the first of the three stalls, and pushes it at right angles to the line

which the belt travels off the belt, and then moves it a short distance further into the machine towards S, and then recedes, leaving the can stationary upon the table until the next sweep, when it is received into the second stall,—that is, between the second and third arms,—and by that movement delivered upon the top of S, and F again recedes, leaving the can to be operated upon by S, in combination with other devices which put the cap upon it. Then by the next sweep F again receives the can after being capped in the third stall,—that is, between the third and fourth arms,—and moves it off the plunger, and again leaves it stationary upon the table, until by the next sweep the fourth arm, H, moves it a step further to a position within the influence of other devices which automatically deliver it to that part of the machine which crimps the flange of the cap tightly upon the can body. The feeder 36 in the defendants' machine necessarily acts in combination with the plungers, of which there are four in that organization, each of which is seated upon a projecting bracket or radial arm attached to a central revolving shaft, which causes the four brackets or radial arms to move continuously in a circle reverse to the continuous circular movement of 36. When a can, impelled by 36, and guided by the curved track and guard, 63, is brought into position upon the plunger seated upon the projecting extremity of one of the constantly turning radial arms, it is by that reverse circular movement released from the concavity, and it does not afterwards come in contact with any part of 36. The differences between F and 36 are radical, and not mere differences of shape and motion. I am not satisfied in my own mind that a true circular continuous movement of any device necessarily produces a fundamental difference from that produced by an eccentric and intermittent movement, but in this case the result produced by the differences in the movement of 36 from the movements of F is radical. A mechanical equivalent must be adaptable to use as a substitute for something else, and competent to perform the functions of a particular device for which it may be substituted. The word "equivalent" means equal in force and effect. 11 Am. & Eng. Enc. Law (2d Ed.) 252. Now, the feeder F, by its own movement, completes the delivery of the cans one at a time upon the plunger, S, and, after they are capped, removes them from it. The feeder 36 only places the cans upon the plungers. It cannot complete the delivery, because it cannot release them by its own movements; and it does not perform any part of the important function of removing the cans from the plungers, nor can it be adapted to perform both of these functions and work in combination with a rigidly located vertical moving plunger. Therefore I hold that 36 is not an equivalent for F. Nor can any combination of the devices in the defendants' machine which do perform all the functions of F be adapted to do the same work as F without entirely reorganizing the different combinations so as to make a different machine.

Claim 5 covers an important part of Jensen's invention, but the question whether this claim is or is not infringed is not important in this particular lawsuit, and for the sake of brevity I will not undertake to make a detailed comparison of this part of the machine with any of the mechanism of the defendants' machine. I say that the question

as to infringement of this claim is not important, because it has been proved by uncontradicted evidence that the defendants' machine can be operated successfully, rapidly, and economically without the set of linked fingers which act as stops upon the can heads while being conducted to the machine upon the traveling belt. Therefore an injunction to prohibit the manufacture and sale of machines having these spacing fingers to act upon the can heads will not hurt the defendants, and, if they dispense with the spacing fingers, infringement of this claim will be avoided, because there will then be no element in their machine to perform the functions of the stop designated by the letter P, which is operated to permit the caps to pass into the machine one at a time by contact of the cans with a trigger designated by the letters N and O. These members of the combination in claim 5, N, O, and P, perform an important function in the Jensen machine, so that the combination will be broken and infringement avoided by making a machine in which that function is not necessary.

The fundamental principle of Jensen's invention is the application of power to automatically receive sheet-metal filled cans in an upright position, and swiftly, accurately, and economically apply tight-fitting flanged covers over the top or open ends. The combination of devices which perform the important part of this operation are comprised in claims 9, 10, and 11 of the patent. These I consider to be the vital parts of the machine. The elements of claim 9 are a vertically moving plunger, designated by the letter S in the drawings; the conical or beveled hole situated above and in line with it; and two segments of a circle with mechanism to cause the two parts to join each other so as to form a complete circular opening smaller than the top of the beveled hole, and situated immediately above it, and to recede so as to enlarge the circular opening. The function of S is to receive the can and push it vertically into the conical guide until the top of the can receives the flanged cover, and then, acting in combination with the mechanism for actuating the movable segments which have supported the cover above the beveled hole, descends the moment the segments recede from each other, so as to release the headed can from the contracted circle. According to the undisputed evidence, this machine is the first one ever designed which in use has proved to be successful in applying tight-fitting covers upon filled cans, and its merits are such as to require liberality in construing these claims, so as to protect the owner of the patent from infringement by mere changes which any skilled mechanic might easily make in the devices which actuate the movable segments of the cap holder. The claim does not specifically mention any particular device for actuating the slides, although the specifications and drawings show the means which the inventor applied; but, giving a liberal construction to the claim, I do not consider that it should be restricted to the use of those particular devices. When this invention was perfected, there were numberless devices of arms, elbows, rings, wheels, levers, wedges, screws, springs, weights, cogs, and cams known to machinists which are adaptable to apply the force required to perform the function of contracting and expanding an open circle formed by movable segments. In the defendants' machine there are beveled holes above and in line with vertical moving plung-

ers through which the open top ends of the cans are pushed into the tight-fitting flanged covers supported above the hole by segmental plates which are movable, and when actuated the parts join each other so as to form a central circular opening through which the top end of the can passes into the cover, and there are actuating devices which cause these plates to form a resting place for the covers, and to recede at the right moment, so as to expand the circular opening and release the cans after the heads have been applied. The function of these segmental movable plates is exactly the same as in the Jensen machine, and the same result is accomplished by exactly the same means. There is this difference: that in the defendants' machine the cap holders are divided into three segments instead of two, and there is some difference in the devices for actuating them, to which further reference is unnecessary. The conical guides or beveled holes in the defendants' machine are similar to the same devices in the Jensen machine, the only difference being that in the defendants' machine as organized there are four conical guides to work in combination with four plungers, instead of the one guide in the Jensen machine. The defendants and their solicitors have labored strenuously to show by evidence and argument a substantial difference between the plungers in the defendants' machine and the Jensen plunger, but it is my opinion that they are alike in form and mode of operation, and perform the same functions in both machines by the same means. It is said that the Letson and Burpee plungers have two motions,—vertical and horizontal; that is, a circular motion on a horizontal plane,—and that the Jensen plunger has no other movement than the vertical. But I find that in the operation of the defendants' machine the plungers do not move at all, except as they are pushed upward by contact of the lower end of the piston, designated by the number 18, with the inclined surface of the cam, 46, as the radial arms which support the plungers revolve upon their central axis. The plungers are always in line with the conical guide into which they push the cans by the only movement which the plunger is capable of making. The lower end of 18 reaches the highest elevation of the inclined plane when the can has entered the can head, and then, as the radial arms continue to revolve, the headed can descends vertically as the lower end of 18 moves downward upon the descending incline of the cam. The plunger itself is a distinct part of the defendants' machine, just as it is in the Jensen machine, and the bracket which supports it is a different thing, and has a distinct movement. It is true that the plungers are carried around and around by the rotation of the brackets, but the can-heading mechanism above, which acts in combination with them, is affected by the same rotary movement. The Jensen machine would not be changed if it were placed intact upon a car, and made to operate as the car travels upon a horizontal plane as a railway track, and yet, by being carried along horizontally, the plunger would have a horizontal movement,—that is to say, it would be moving horizontally as the car traveled,—and that horizontal movement would be quite similar to the movement which affects the plungers in the defendants' machine by the rotary action of their supporting brackets or radial arms.

The tenth claim comprises the plunger, S, the conical guide or bev-

eled hole in combination with an upper plunger, which presses upon the can head, and follows it down by gravitation or other force so as to steady the can in its descent. There are similar upper plungers working in combination with the plungers, which push the cans upward into the can heads, in the defendants' machine, but it is contended that infringement of this claim has been avoided because the defendants' upper plungers are not required to steady the can, other means being provided to that end. It is not denied that the upper plunger may to some extent steady the cans in their downward movement, and the testimony shows that if a can for any reason sticks in the hole, so that it does not descend by gravity, the upper plunger acts as a positive force to push it down. It is my opinion, however, that the intention of the builder of an infringing machine has nothing to do with the question of infringement, because a device which is in fact the equivalent of another in force, and which produces the same effects by the same means, is an equivalent, notwithstanding any failure of its maker to comprehend in his design all the effects which it is capable of producing. I can find no substantial difference between the upper plungers in the two machines, either in form, effect produced, or the means by which the effect is produced.

It is unnecessary to discuss the eleventh claim any further than to say that among the devices making the combination of that claim there is included a part which I have heretofore referred to as the second feeder, F, which is not reproduced in the defendants' machine, as I have heretofore explained, and therefore the eleventh claim is not infringed by the defendants' machine.

By the final decree the court will award a perpetual injunction against the manufacture, sale, and use of machines embodying the combinations specified in claims 5, 9, and 10 of the Jensen patent, and will deny relief as to claims 1, 3, and 11. The case will also be referred to a master, if necessary, to state an account, or ascertain the amount of damages which the complainant is entitled to recover.

CONSOLIDATED STORE-SERVICE CO. v. WINTERS et al.

(Circuit Court, W. D. Arkansas, Texarkana Division. December 15, 1902.)

1. PATENTS—INFRINGEMENT—CASH CARRIERS.

The Osgood patent, No. 357,851, for a store-service apparatus, discloses a patentable invention which was not anticipated, and is valid. Also *held* infringed.

In Equity. Suit for infringement of letters patent, No. 357,851, for a store service apparatus, granted to Edwin P. Osgood February 15, 1887. On final hearing.

C. B. & Henry Moore and Guy Cunningham, for complainant.
Scott & Jones, for defendants.

ROGERS, District Judge. The validity of complainant's patent, No. 357,851, has been recognized in the following cases: Consolidated Store-Service Co. v. Siegel-Cooper Co. (C. C.) 103 Fed. 489;

Id., 46 C. C. A. 599, 107 Fed. 716; Same v. Herzog (C. C.) 100 Fed. 299, affirmed in 45 C. C. A. 159, 105 Fed. 985; Same v. Seybold, 45 C. C. A. 152, 105 Fed. 978. Relief was refused in all these cases, on the ground that there was no infringement. The same patent was also recognized in the following cases: Store-Service Co. v. Whipple (C. C.) 75 Fed. 27; Same v. Wilson (C. C.) 83 Fed. 201. Affirmative relief was granted in both these cases, the validity of the patent being recognized, and the defendants enjoined on the ground of infringement. In Wilson v. Store-Service Co., 31 C. C. A. 533, 88 Fed. 286, the circuit court of appeals for the First circuit dissolved a preliminary injunction, issued merely on affidavit, on the ground that the patent was too doubtful to justify it; but the court is informed that on final hearing, the defense having taken no testimony, the decree was entered for the plaintiff.

In view of these decisions, the court is of opinion that the validity of the patent in controversy ought to be considered as established; and, independent of that, determines for itself that patent 357,851 discloses a patentable invention which was not anticipated, and is valid; although, as said by Judge Shipman in Consolidated Store-Service Co. v. Siegel-Cooper Co., supra, it is entitled to a narrow construction.

It is not necessary, for the purposes of this case, to pass upon the validity of patent 293,192, in regard to the validity of which there seems to be some conflict in the decisions of the courts. My mind inclines to the view, however, that patent 293,192 also involves a patentable invention.

If the court is correct in holding that patent No. 357,851 is valid, and embraces a valid and patentable invention, then the only remaining question is as to whether or not there was an infringement in this case. The defense has taken no testimony whatever, and the only evidence bearing upon the question of infringement grows out of the testimony of P. G. Roquemore, which, by stipulation, is taken as his deposition, and wherein it appears that the defendants, after the 1st day of January, 1897, used a system of store-service apparatus consisting of four cash carriers, branded "Standard," in their store in Texarkana, Ark., and that the same were used up to within 18 months before the filing of the bill of complaint in this suit; and that the cut on opposite side of a sheet of paper attached to his deposition is a fair representation of the four cash carriers branded "Standard," now in the basement of the store formerly occupied by Joe Winter & Co., the differences "being more of an artistic than of a mechanical nature." On the opposite side of the paper referred to is a cut of the four cash carriers branded "Standard." A careful comparison of this "Standard" apparatus with the invention of the complainant leads me to the conclusion that the principles involved in both are precisely the same. There are some differences as to the methods of staying the same to the ceiling and walls of the building, but this is no part of the patentable apparatus, nor does it involve anything that is patentable. But the taut wire, the method of keeping it taut, the construction of the car, and the method of operating the car, as well as stopping it, are precisely the same as those covered by the Osgood patent, which is patent No. 357,851, owned by the complainant. True, in the "Standard" ap-

paratus the car, instead of being pushed by hand, is operated by a lever; but the lever and pulley used for that purpose are neither novel nor patentable, and involve no new principle whatever.

I conclude, therefore, that the "Standard" cash carrier used by the defendants was an infringement upon the Osgood patent. In this case it was conceded that the damages sustained were nominal, and counsel waived the reference of the case to a master. The decree of the court, therefore, is for the complainant for a permanent injunction. It is so ordered.

BURROWS et al. v. GOWER.

(District Court, D. Massachusetts. December 26, 1902.)

No. 1,257.

1. COLLISION—FOG SIGNALS—SAILING VESSEL LYING TO.

A sailing vessel lying to in a fog, but having some of her sails up, is "under way," and is governed by article 15, cl. "c," of the international navigation rules, and where the wind is on her starboard bow she is on the starboard tack, and the proper fog signal is one blast.

In Admiralty. Suit for collision.

Wm. A. Pew, Jr., for libelants.

Carver & Blodgett, for respondent.

LOWELL, District Judge (after finding the Gower at fault). The Story I hold to blame for not sounding her fog horn until it was too late. Counsel for the libelee also contended that the signal she gave, one blast, was incorrect, as she was not "sailing," in the ordinary sense of the word, but was rather lying to. I have therefore to consider what signal is required by the international rules from a vessel lying to in a fog. The question calls for an examination of the rules in some detail.

The Story was under way, within the definition of the international rules. Mars. Mar. Coll. 405, 431; The Columbian, 100 Fed. 991, 41 C. C. A. 150. The Alfredo (D. C.) 30 Fed. 842, affirmed in (C. C.) 32 Fed. 240, was decided under the rules of 1885, which did not contain the existing definition. Act 1885, c. 354; 23 Stat. 438. If a vessel under way, with the wind on her starboard bow, is necessarily on the starboard tack, then the Story should have given one blast on her horn, whether she was making any headway or not. Apart from article 15, cl. "e," the above is the correct construction of the international rules. This appears from a comparison of clauses "a," "b," and "c." Clause "a" deals with a steam vessel "having way upon her,"—a phrase carefully distinguished from the phrase "under way." Clause "b" deals with a steam vessel "under way, but stopped, and having no way upon her,"—a phrase which indicates that a vessel "stopped and having no way upon her" is yet deemed to be "under way," within the purview of article 15. Clause "c" deals with a sail-

¶ 1. Signals of meeting vessels, see note to The New York, 30 C. C. A. 630.

ing vessel "under way," including, it seems, the case of a sailing vessel "having way upon her," and that of a sailing vessel "stopped and having no way upon her." Such a vessel must be deemed to be (1) on the starboard tack, or (2) on the port tack, or (3) with the wind abaft the beam. No fourth case is supposed possible, for, if there were a fourth case, it would not be provided for by the rules. Clause "d" deals with any vessel at anchor, whether a steam or a sailing vessel. Thus far all is plain. The doubt is introduced by clause "e." This deals with three vessels. All come within the general classification of clauses "a" and "c," but they are by clause "e" specially excepted therefrom. With the first two exceptions—that of a vessel towing and that of a vessel laying or picking up a cable—we are not here concerned. Is a vessel lying to, with some of her sails up, "a vessel under way, which is unable to get out of the way of an approaching vessel through being not under command, or unable to maneuver as required by the rules"? Such a vessel is not wholly without ability to maneuver. Her condition is not the result of an accident, within the terms of article 4, cl. "a." On the other hand, she is not able to maneuver rapidly, and she is not under immediate command. Article 9, cl. "d," shows that the situation of a vessel, fishing like the *Story*, is recognized to be unlike that of a vessel sailing in the ordinary way; but the application of that clause is specifically limited to the coasts of Europe, and American fishermen must govern themselves as if that clause did not exist. Upon the whole, I think that clause "c" of article 15, rather than clause "e," applies, and that a signal of one blast is proper in the case supposed. See the earlier form of article 15, cl. "e" (29 Stat. 888). I am disposed to agree with Mr. Marsden (page 430) that article 15, cl. "e," must be read in connection with article 4, cl. "a," which deals with a vessel "which from any accident is not under command." The signals required by article 4, cl. "a," "are to be taken by other vessels as signals that the vessel showing them is not under command, and cannot therefore get out of the way." Article 4, cl. "d." It follows that the signal of the *Story*, when given, was proper. The interpretation thus put upon the international rules is, I believe, that generally followed in practice. In this article, as in some others, the international rules are loosely and ambiguously expressed.

Decree for half damages and costs.

COLLIER v. MUTUAL RESERVE FUND LIFE ASS'N.

(Circuit Court, W. D. Arkansas, Ft. Smith Division. December 30, 1902.)

1. FOREIGN CORPORATIONS—SERVICE UNDER ARKANSAS STATUTE—ATTEMPTED WITHDRAWAL FROM STATE.
Sand. & H. Dig. Ark. § 4137, requires foreign insurance companies, as a condition to the doing of business in the state, to file a stipulation with the auditor, agreeing that any legal process may be served upon the auditor or upon an agent designated, with the same effect as though served upon

¶ 1. Service of process on foreign corporations, see note to *Eldred v. American Palace Car Co.*, 45 C. C. A. 3.

the company within the state. It further provides that, "so long as any liability of the stipulating company to any resident of the state continues, such stipulation cannot be revoked or modified, except that a new one may be substituted, so as to require or dispense with service at the office of said company within the state." *Held*, that a foreign life insurance company, which entered the state and did business therein, filing the required stipulation designating an agent, was bound by the statute, which became a part of its contracts, and could not, after securing a large number of policies in the state, withdraw itself from the jurisdiction, and deprive the holders of such policies of the right to sue it therein by canceling the appointment of such agent, and revoking the authority of all its other agents; and that, in an action on one of such policies it was bound by service made on its agent so designated and on the state auditor.

On Motion by Defendant to Quash the Service of Summons.

Hill & Brizzolara, for plaintiff.

Rose, Hemingway & Rose, for defendant.

ROGERS, District Judge. This suit was brought in the state court, and removed by the defendant to this court. A motion is now filed by the defendant to quash the service, for the reason, as alleged, that at the time of said service it was not doing business in the state of Arkansas, nor did it have any agent therein. The record shows that the return of the sheriff is in due form, and was made both upon Geo. B. Rose and upon T. C. Monroe, auditor of the state of Arkansas. A stipulation has been filed by which it is agreed:

"That the defendant company complied with the statutes of Arkansas in regard to doing business in the state, and appointed Geo. B. Rose as its agent upon whom service of process might be served, and gave bond to the state as required by statute, and while so doing business in the state issued the policy sued upon. That subsequent to the issuance of said policy the company revoked the power of its agents in the state of Arkansas, and revoked the appointment of said Geo. B. Rose, and after it revoked the appointment of its agents it collected its premiums on policies through local banks from its policy holders; and prior to the institution of this suit it ceased to collect through local banks, and sent notices direct to its policy holders to pay at the home office in New York, and the policy holders have done so under the direction of the defendant. That the defendant company has a large number of outstanding policies in the state, some ten of which are in the city of Ft. Smith, Ark., and it is regularly collecting premiums therefrom; and all of said policies were issued while said company was authorized to do business in the state. That no appointment of agents has been made since the revocation heretofore referred to, and no agent has been kept within the state for the service of process, unless the auditor of state and the said Geo. B. Rose are its agents under and by virtue of the statutes in such case."

Section 4137, Sand. & H. Dig. Ark., provides as follows:

"No insurance company, not of this state, nor its agents, shall do business in this state, until it has filed with the auditor of this state a written stipulation, duly authenticated by the company, agreeing that any legal process affecting the company, served on the auditor or the party designated by him, or the agent specified by said company to receive service of process for the company, shall have the same effect as if served personally on the company within this state. And if such company should cease to maintain such agent in this state, so designated, such process may thereafter be served on the auditor; but so long as any liability of the stipulating company to any resident of this state continues, such stipulation can not be revoked, or modified, except that a new one may be substituted, so as to require or dispense with service at the office of said company within this state, and that such service,

according to this stipulation, shall be sufficient personal service on the company. The term 'process' includes any writ, summons, subpoena, or order, whereby any action, suit or proceedings shall be commenced, or which shall be issued in or upon any action, suit or proceedings."

By the stipulation of the parties it appears that, when the policy sued on was issued, the defendant company was regularly doing an insurance business in the state. After it ceased to solicit business further in the state, for a time it collected its premiums upon policies issued while it did business in the state through the instrumentality of banks, and at the time the suit was brought premiums upon policies issued at the time the company was doing business in the state were collected by written notices sent to the assured through the mails, who made their remittances to the head office at New York. It is contended by the defendant company that it was not doing business at the time this suit was brought in the state; that it had previously revoked its agencies; and that under those circumstances no service could be made upon the auditor or Geo. B. Rose, who had been appointed its agent under the statute above quoted. The contention amounts to this: That, after the company ceased to do business in the state, and undertook to revoke the power of its agents, no suit could be brought against the company, even if service might be had upon one of its general agents, who might be found within the territorial jurisdiction of the court. The court is of the opinion the contention is not tenable, and the motion is overruled, upon the authority of *Insurance Co. v. Spratley*, 172 U. S. 603, 19 Sup. Ct. 308, 43 L. Ed. 569; *Magoffin v. Association* (Minn.) 91 N. W. 1115. See, also, *Pervanger v. Surety Co.* (Miss.) 32 South. 909; *Cotton Co. v. Yates*, 69 Ark. 396, 63 S. W. 997. In the opinion of the court the defendant company, having gone into business in the state of Arkansas while the statute hereinbefore quoted was in full force, and the policy sued on having been executed while said company was so doing business in the state, it cannot now, in the face of the provisions of that statute, revoke the authority of its agent, Geo. B. Rose, so as to deprive the holder of the policy of the right to make service upon him and bind the company thereby; and, moreover, that the service either upon the auditor of state or upon the said Geo. B. Rose was ample, and binding upon the defendant to give this court jurisdiction over the company. The statute quoted, under the circumstances stated, became a part of the policy sued on,—as much so as if it were written on its face. Moreover, it was an irrevocable contract, which the company could not avoid until it satisfied the terms of the statute, which could not be done so long as any liability to any resident of this state, entered into while the company was doing business in the state, continued.

The motion is therefore overruled.

In re SIMPSON.

(District Court, D. Maine. December 22, 1901.)

1. SEAMEN—OFFENSES—REPEAL OF STATUTE BY IMPLICATION.

The provision of Rev. St. § 5359 [U. S. Comp. St. 1901, p. 3639], which makes it a criminal offense "if any one of the crew of an American vessel on the high seas, or other waters within the admiralty and maritime jurisdiction of the United States, endeavors to make a revolt * * * on board such vessel," was not repealed by implication by the provision of the shipping commissioners' act of June 7, 1872 (Rev. St. § 4596, par. 7 [see U. S. Comp. St. 1901, pp. 3113, 3115]), which makes it an offense for any seaman to "combine with any others of the crew to disobey lawful commands."

On Petition of William Simpson for a Writ of Habeas Corpus.

The defendants were indicted for a violation of section 5359 of the Revised Statutes of the United States while seamen on the American schooner Helen M. Atwood, and while that vessel was lying at anchor in the Kennebec river, near the city of Bath, in the district of Maine. The indictment contained three counts, each alleging an endeavor upon the part of the defendants to create a revolt. The jury returned a verdict of guilty as to each defendant, and they were sentenced to imprisonment. One of the defendants immediately filed an application for a writ of habeas corpus, alleging that section 5359, so far as it related to the offense charged in the indictment, had been repealed by paragraph 7 of the act of June 7, 1872 (17 Stat. 273; section 4596 of the Revised Statutes of the United States), and that the latter act had been repealed by the act of December 21, 1898 (30 Stat. 760 [U. S. Comp. St. 1901, p. 3114]).

On the trial of the criminal, HALE, District Judge, charged the jury as follows:

No higher duty devolves upon the citizen of a representative government, a government of the people, than the duty of serving upon a jury; that is, the duty of standing between man and man in the controversies that come into the courts of justice. And especially is this true when you are standing between the government and persons accused of crime. Now, gentlemen, this is your first case, and you will have only criminal cases this term; so that, without giving you any general instructions as to the rules of evidence pertaining in civil matters, I will give you some general instructions as to the rules in criminal cases.

In the first place, without going into the reason for the rule, the first primary rule to govern your conduct in criminal cases is that every man is presumed to be innocent until the contrary is proved. And, if there be reasonable doubt of his guilt, the jury are to give him the benefit of such doubt; that is, if there be any reasonable doubt of his guilt, he cannot be held. Now, a doubt that requires an acquittal must be far more serious than the doubt to which all human conclusions are subject. It must be a doubt so solemn and so substantial as to produce in the jury grave uncertainty as to the verdict to be given. It is not a mere possible doubt. To instruct you in the language of Chief Justice Shaw, "A reasonable doubt is not a mere possible doubt;" but you, as reasonable men, are to weigh all the testimony in the case, and decide whether there is any real reason to doubt or not. And I, of course, wish to emphasize that a reasonable doubt is not a frivolous doubt, but is such a doubt as I have just explained. Now, in passing upon a case like this, all the facts in the case are for your consideration. It is for you to judge of the credibility of the witnesses. It is for you to judge as to the weight that shall be given to any evidence

¶ 1. Repeal of statutes by implication, see note to *Bank v. Weidenbeck*, 38 C. C. A. 136.

presented in the case. You may credit the whole or only a part of any evidence that is offered; and in this I can give you no rule to govern you, except to say that in all questions of fact you are the judges. As Chief Justice Parker has put it: "You can believe the whole, you can discredit the whole or any part, of the testimony of any witness that has testified in the case, according as the testimony of such witness shall impress your minds as being worthy or unworthy of belief. You may consider the age, the intelligence, the interest in the case, the apparent prejudice, if any, and all other circumstances in evidence before you in the determination of the credibility of witnesses." And in that regard it is not for me to tell you what evidence is or is not sufficient to establish a given fact, but it is for me to tell you whether the whole testimony is sufficient to sustain the government's burden. To quote further from Chief Justice Parker—and I do so because it is so excellently stated—in giving the distinction between the power of the judge and the power of the jury, he says: "It is the privilege of the jury to ascertain the fact, and that of the court to declare the law. And, should the judge interfere with his opinion upon the testimony in order to influence the minds of the jury, he would step out of the province of a judge into that of the advocate." So that, gentlemen, I instruct you that on all questions of law you are to take the law from the court, and, if the court is in any way incorrect, and does not give you sufficient and ample instructions, it will be corrected by the appellate tribunal.

Coming to this case, gentlemen, the section of the statute under which this indictment is drawn is brief, and I will read it: "If any one of the crew of any American vessel on the high seas, or other waters within the admiralty and maritime jurisdiction of the United States, endeavors to make a revolt or mutiny on board such vessel, or combines, conspires, or confederates with any other person on board to make such revolt or mutiny, or solicits, incites, or stirs up any other of the crew to disobey or resist the lawful orders of the master, or other officer of such vessel, or to refuse or neglect their proper duty on board thereof, or to betray their proper trust, or assembles with others in a tumultuous and mutinous manner, or makes a riot on board thereof, or unlawfully confines the master, etc., he shall be punished," etc. Now, this indictment charges that these defendants who are named here in the indictment—I will not read it in full—have violated the provisions of this statute. The first count sets forth simply an endeavor to make a revolt within this statute. The second count sets forth likewise the endeavor, and describes the endeavor as being made by a conspiracy to do certain things alleged. The third count charges distributively a conspiracy to endeavor to do the things set out by the indictment. So that you have three counts in the indictment. Now, you have heard the evidence offered under the allegations in the first count, and, as I say, you are the judges of the fact. And, gentlemen, from the fact that there is no evidence offered upon the other side, you are not relieved from the responsibility of finding beyond a reasonable doubt all the facts necessary in order to sustain a verdict, although it may or may not render your task an easy one. It is alleged by the government that these men upon this vessel, being the crew of an American vessel, endeavored to make a revolt. In the first place, you must find, in order to bring the case within this statute, that they are the crew of an American vessel. You have heard the testimony on this point. You cannot find them guilty unless you find beyond a reasonable doubt that they are the crew (that is, persons pertaining to the conduct of the vessel), and that it is an American vessel (that is, that it is a vessel owned by American citizens). You have heard the testimony of the captain in that regard,—which is competent testimony,—that the owners are American citizens, and I know of no evidence in any way to contradict that statement of the captain. It is for you to say, however. That is one of the elements for you to find before you can convict,—that these respondents are of the crew of an American vessel. You must further find that the offense was committed within the admiralty and maritime jurisdiction of the United States. In that regard I do not remember any conflict in the testimony; and if you find, from the testimony, that the alleged offense was committed when the vessel was in the tide waters of the Kennebec river, I instruct you that that is within

the admiralty and maritime jurisdiction of the United States. So that, in order to sustain the indictment in that regard, you must find that the vessel was in the place alleged by the testimony, namely, in the tide waters of the Kennebec river.

Now, then, we come to the main allegations of the indictment,—that they endeavored to make a revolt and a mutiny on such vessel. Let us proceed knowing precisely where we stand. A revolt or a mutiny is an uprising against constituted authority. Now, did they endeavor to effect a rising up against the constituted authority of the master or other competent and controlling officer of the ship? And, no matter what any former statute has been, if you find that they did endeavor to make such a rising, then you will find that part of the indictment. And upon that question you will want to know, not only what a revolt is, but also what is a combination, because the statute says further "combines or conspires." But before we come to that matter of conspiracy and combination, let us take the first count, namely, that these men did endeavor to make a revolt. Now, at law a revolt is, as I have said, an uprising with a view to disobey the lawful commands of the master or other officer, accompanied or followed by actual disobedience. And if you find that these men who are charged with this offense, or any two of them, did that, then you will find that that element in the first count is sustained. As I have already said to you, gentlemen, you are the judges of the fact, and you will remember the testimony. But I instruct you, gentlemen, that with what transpired before the respondents were on board the vessel you have nothing to do. The statute confines the offense to any person on board; so that, until these men are on board the vessel, they are not chargeable with this offense, under this section of the statute. You will remember the testimony in this regard. In the first instance, the testimony of the captain and the mate that these men came before the captain, and found fault with their sleeping accommodations; that the captain gave some orders and instructions about it, and put one of them into another room,—not in the fore-castle; and you will remember the testimony that they did then what they did in contravention to the authority of the captain. Now, it must be a disobeying of the lawful commands of the captain. There must be a disobeying of his lawful orders, and an endeavor to make a revolt, and that revolt is constituted by disobeying the master's lawful commands; so that it remains for me to instruct you, as a matter of law, whether the commands of the captain were lawful commands. Well, you have heard the testimony, of which I have just spoken, in regard to the matter of sleeping accommodations. And then further you have heard the testimony that these men came before the master. You remember the incident at the fore-castle, as to what was done when the master gave the command for them to go to work, or "turn to," as he put it, and that they did not obey these commands. You have heard the testimony, and it is for you to find the facts. Even though the testimony is undisputed, that does not relieve you from the responsibility of finding the facts. As I say, it may render your task more or less easy, but your responsibility still remains to find what the facts are. But it is for me to charge you whether these commands of the captain were lawful commands. If you find that the testimony of the captain and the mate is true as to what the captain said and ordered the men to do, then I instruct you, for the purposes of this trial, that these commands were lawful commands. That leaves the question of fact clean and clear for you to find whether they did endeavor to incite and make a revolt, constituted, as I have said, by disobeying these lawful commands of the captain.

Now, under the second count the allegation is that these respondents endeavored to make a revolt by a combination,—by a conspiracy. Now, I hardly need instruct you what in fact a combination or conspiracy is, for you, as sensible men, know what is meant by a combination or a conspiracy; but, in brief terms, it is a union or an alliance of persons for the prosecution of a common object, and a confederacy to combine or conspire in the entering into such a combination. Now, the questions of fact may be proved either by direct evidence or by circumstantial evidence. It would be competent for the government, if it could, to introduce testimony of any one who heard these men conspiring together,—getting up a scheme among them—

selves to incite and endeavor to make a revolt. And it is equally competent for the government to show this by circumstantial evidence; or, as a distinguished text-writer states it: "The fact of conspiring may be inferred from the circumstances, and the concurring conduct of the defendants need not be directly proved." That is perfectly obvious. All things, as a rule, that may be proved directly, may be proved by circumstantial evidence. Under this count for inciting and endeavoring to make a revolt the government says this: That when the captain addressed these defendants, and any one of these defendants made a statement as to what he intended to do, he said, "We have done" so and so, and that is assented to, and the government claims that you may fairly infer from such testimony that all these men standing by and consenting have been guilty of a combination; else, it says, why should they stand by and assent, when they are practically charged with facts about which they must all be cognizable? And I instruct you, gentlemen, that a combination may be proved in that way, and you may competently find from such circumstances that a combination to revolt was entered into. And I also instruct you, as a matter of law, that, if there was a confederacy and a combination by these respondents to disobey the lawful commands of the master or mate or a competent officer in charge of the ship, and to refuse and neglect their proper duty, and there was actual disobedience, that constitutes an endeavor to commit a revolt. Because, as I instructed you in the first place, you must bear in mind that this indictment is not for making a revolt; it is for endeavoring to make a revolt. The statutes of the United States are so careful to uphold the authority of the officers of a ship that they properly make it an offense to endeavor to make a revolt, and, more than that, to conspire to endeavor, to form a conspiracy to carry out their endeavor.

Now, in the third count the allegation is squarely that there was a conspiracy to endeavor to do all these things, and with other persons to make such revolt or mutiny. You will see what the language of the indictment is. And I instruct you, as in the second count, that it is sufficient to constitute this endeavor to commit a revolt if you find that there was a conspiracy and a combination by the defendants to disobey the lawful commands of the master, and refuse and neglect their proper duty. And I believe I have instructed you fully as to the meaning of the several words,—what a combination or conspiracy is and what a revolt is,—and a mutiny under the statute is substantially the same as a revolt; that is, if there is an endeavor to rise up against the constituted authority of the master, that is sufficient, under this statute, to constitute an attempted mutiny or revolt. I again repeat that it is your duty to find these several facts in order to sustain the indictment, and in order to find these defendants, or any of them, guilty, and to find these facts beyond a reasonable doubt. I have already instructed you what a reasonable doubt is.

I am asked by counsel for the respondents to charge you that, to support the third count of this indictment, the government must prove beyond a reasonable doubt that a conspiracy, confederacy, and combination was made between the members of the crew to refuse to obey the lawful commands of the master or other officer of the vessel. I give you that instruction. I have already given you substantially that. I am further asked to instruct you that, in order to convict the respondents in the case under the first count of the indictment, it is necessary for the government to prove that the defendants used some violence, fraud, force, or intimidation; that the government must prove that beyond a reasonable doubt. That instruction I refuse. Whatever may have been the law under a previous statute, it is not the law now. I have already instructed you touching this point, and will not repeat.

Gentlemen, I want to repeat that on all questions of fact, whether there seems to be any contradiction in the testimony or not, you are the judges of the fact, and are to find affirmatively, beyond reasonable doubt, these several allegations that I have stated to you, before you can find the defendants guilty. It is for you to take the case, and as reasonable men pass upon the several allegations that I have brought to your attention. You may either find a verdict on each count,—for instance, on the first count you may find the defendants guilty or not guilty, as the case may be, and so with the

other counts,—or you may find a general verdict. With these instructions, gentlemen, I commit the case to you, again repeating that all questions are before you for your examination,—the character of the witnesses, and their appearance upon the stand, whether you have any reason to believe they are in any way to be discredited as to their likelihood of telling the truth,—and you are to pass upon these questions precisely as you would, as reasonable men, pass upon questions in the business of life. And I have no doubt you will, without difficulty, come to a decision in this case.

Isaac W. Dyer, U. S. Atty.

William H. Gulliver, for defendants.

HALE, District Judge. The petitioner, with four others, was indicted at the present December term of this court under section 5359 of the Revised Statutes of the United States [U. S. Comp. St. 1901, p. 3639], which section is as follows:

"If any one of the crew of any American vessel on the high seas, or other waters within the admiralty and maritime jurisdiction of the United States, endeavors to make a revolt or mutiny on board such vessel, or combines, conspires, or confederates with any other person on board to make such revolt or mutiny, or solicits, incites, or stirs up any other of the crew to disobey or resist the lawful orders of the master, or other officer of such vessel, or to refuse or neglect their proper duty on board thereof, or to betray their proper trust, or assembles with others in a tumultuous and mutinous manner, or makes a riot on board thereof, or unlawfully confines the master, or other commanding officer thereof, he shall be punished by a fine of not more than one thousand dollars, or by imprisonment not more than five years, or by both such fine and imprisonment."

The first count of the indictment charges an endeavor to make a revolt, and shows how that endeavor was carried out. The second count charges the endeavor to make a revolt by conspiracy. The third count charges a conspiracy to make a revolt. The respondents were tried before a jury. The jury returned a verdict of guilty. The respondents were then sentenced, and this petitioner is now serving his sentence in the Portland jail.

The contention of the petitioner is that the proceedings under this indictment were a nullity, the court having no jurisdiction, because the statute under which the indictment was found has been repealed, so far as it applied to the particular offense charged in the indictment. The supreme court in *Ex parte Bigelow*, 113 U. S. 328, 5 Sup. Ct. 542, 28 L. Ed. 1005, says:

"It may be confessed that it is not always very easy to determine what matters go to the jurisdiction of a court, so as to make its action, when erroneous, a nullity, but the general rule is that, when the court has jurisdiction by law of the offense charged and of the party who is so charged, its judgments are not nullities."

In the case at bar it is urged that, the statute under which the indictment was found having been repealed so far as it applied to the particular offense, the court had no jurisdiction, and that the petitioner should be discharged. Upon an application of this kind, if the cause of imprisonment fully appears by the petition, the court may, without using the writ, decide whether, upon the facts of the petition, the prisoner would be discharged if brought before the court. It then becomes incumbent upon us to decide whether the statute under which this indictment was drawn has been repealed so far as

it applies to the particular offense. Upon examining the statute historically, it is found that the act of 1872 (section 4596, par. 7, Rev. St. U. S. [See U. S. Comp. St. 1901, pp. 3113, 3115]) provided that:

"Whenever any seaman who has been lawfully engaged, or any apprentice to the sea service, commits any of the following offenses, he shall be punished as follows: * * * (7) For combining with any others of the crew to disobey lawful commands, or to neglect their duty, or to impede the navigation of the vessel, or the progress of the voyage, by imprisonment for not more than twelve months."

It is urged that this paragraph 7 by implication repeals so much of section 5359 [U. S. Comp. St. 1901, p. 3639] as relates to combining to disobey or resist the lawful commands or orders of the master or other officer. In considering the question of the repeal of a statute, it is a rule of the federal courts that "a later act does not repeal an earlier one by implication, unless their provisions are clearly inconsistent and repugnant," and that "repeals by implication are not favored, and, where sections of earlier and later acts can, by any reasonable construction, stand together, they must so stand." *Gowen v. Harley*, 6 C. C. A. 190, 56 Fed. 973. In *Arthur v. Homer*, 96 U. S. 137, 24 L. Ed. 811, the court says: "To induce the repeal of a statute by implication of inconsistency with a later statute, there must be such a positive repugnancy between the two statutes that they cannot stand together." Now, does such repugnancy exist between the two sections above referred to? Section 5359 of the Revised Statutes of the United States [U. S. Comp. St. 1901, p. 3639] was originally a part of Act April 30, 1790, c. 9, § 19 (1 Stat. 115). It was amended into its present form by Act March 3, 1835, has so continued since, and now appears as part of title 70, c. 3, entitled "Crimes." I have already quoted above the language of the statute of 1872, namely, the shipping commissioners' act (section 51, par. 7 [U. S. Comp. St. 1901, p. 3114]). This shipping commissioners' act continued in force until 1874, when the following act was passed:

"That none of the provisions of the act entitled 'An act to authorize the appointment of shipping commissioners of the several circuit courts of the United States, to superintend the shipping and discharge of seamen engaged in merchant ships, belonging to the United States, for the further protection of seamen' shall apply to sail or steam vessels engaged in the coastwise trade, except the coastwise trade between the Atlantic and Pacific coasts." 18 Stat. 64 [U. S. Comp. St. p. 3064].

This act of 1874 has been construed to repeal the act of 1872 so far as it applied to vessels engaged in the coasting trade. *U. S. v. Buckley* (D. C.) 31 Fed. 804. This repeal did not, however, change the act of 1835 (section 5359), under which the indictment is drawn. The act of 1872, as amended, continued until December 21, 1898, when congress re-enacted section 4596, omitting the seventh paragraph, which I have above quoted. 30 Stat. 760, § 19 [U. S. Comp. St. 1901, p. 3114]. It is urged by the petitioner that the act of 1872 repealed the statute under which this indictment is drawn so far as it relates to the offense charged, and that, the statute of 1898 repealing the seventh paragraph, namely, with reference to combining with any others of the crew to disobey the lawful commands, etc., this leaves no legislation upon the subject. It is unquestionably a well-

settled rule that a statute may be repealed by implication, the last act being treated as the last expression of congress upon the subject. And also the repeal may be applicable only to a part of the statute to which the subject-matter relates. If paragraph 7 of the act of 1872 did repeal by implication section 5359, it did so only so far as the latter act related to the "combining upon the part of the men to resist the lawful commands of the master"; but an examination of the indictment upon which the petitioner was convicted shows that the charge in that indictment is as set forth above. The offense was that he endeavored to make a revolt, the several counts setting forth this endeavor as above stated. The charge in the indictment is not that he combined to do any unlawful act; so that the act of 1872 was not intended by congress to have any bearing upon the offense charged in this indictment, and it has no bearing upon the present proceedings. Section 5359 is clearly not repealed by the act of 1872, so far as an endeavor to make a revolt is concerned. Section 5359 properly appears in the compilation of the laws of the United States just issued, and also in the compilation of the navigation laws made by the commissioner of navigation. This fact is affirmed by the opinion of Judge Hammond, of the United States circuit court for the Western district of Tennessee, October 2, 1882,—U. S. v. Huff, 13 Fed. 630,—which decision was 10 years after the enactment of 1872, and discusses offenses similar to this in the present proceeding.

The application for the writ must be denied.

COMMONWEALTH OF VIRGINIA v. DE HART.

(Circuit Court, W. D. Virginia. December 23, 1902.)

1. REMOVAL OF CAUSES—PROSECUTION OF INTERNAL REVENUE OFFICER—ACTS DONE UNDER COLOR OF OFFICE.

A criminal prosecution for an assault committed by defendant in repelling an attack made upon him while acting as a posseman under appointment by a deputy United States marshal, and while assisting in an effort to find and arrest a person charged with a violation of the revenue laws, is removable into the federal court, under Rev. St. § 643 [U. S. Comp. St. 1901, p. 521], the defendant having been at least acting "under color of" office, or in the exercise of a "right or authority claimed" under a revenue law, within the meaning of said section; and it is immaterial, for purposes of removal, what motive actuated his assailant or the officer in defending himself.

Criminal Prosecution Removed from State Court. On motion to remand.

Wm. A. Anderson, Atty. Gen., for Virginia.
Thos. L. Moore, U. S. Dist. Atty.

McDOWELL, District Judge. The point for decision in this case arises on a motion by the state to remand this cause to the state court. The defendant was indicted by the grand jury of Floyd county for a felonious assault on one N. K. Thomas. On an informal petition, subsequently amended, filed under section 643, Rev. St. U. S. [U. S. Comp. St. 1901, p. 521], the cause was removed to this

court. The motion to remand is based on the contention that the petition as amended does not allege the state of facts necessary to give this court jurisdiction. So far as now material, the amended petition alleges that a short time prior to the alleged assault the petitioner, while acting as a posseman under a deputy collector of internal revenue, had assisted in destroying an illicit distillery belonging to the aforesaid N. K. Thomas; that he appeared as a witness, and had testified against Thomas at the preliminary hearing, and was recognized as a government witness to appear and testify against Thomas at the then next term of the federal court. At this juncture—between the examining trial and the term of court at which Thomas was to be tried for operating an illicit distillery—the petitioner was summoned by a deputy United States marshal to assist in an effort to arrest one Agee for a violation of the federal revenue laws. “While in the discharge of such duty, and while acting under and by authority of said officer, your petitioner was set upon by said N. K. Thomas, who told your petitioner that, on account of his having reported said Thomas’ still to the government officers, and on account of his having, while acting under and by authority of a deputy collector of the United States, assisted in the cutting up and destruction of said Thomas’ still, and on account of the evidence given by your petitioner against him before the commissioner, and to prevent such evidence being repeated by your petitioner at the November term of the said district court, he intended to kill your petitioner. As he said this, said N. K. Thomas thrust his hand in his pocket and drew therefrom a pistol. Your petitioner, acting in the capacity of a government officer, also had on his person a pistol, which he drew from his pocket, and, without attempting to fire on the said N. K. Thomas, struck him in self-defense, and thereby prevented the said N. K. Thomas from carrying out the threats made not only at that time, but on previous occasions.” There is no room for doubt that a deputy marshal, while executing, or on the way to execute, a warrant for the arrest of one charged with a violation of an internal revenue statute, is “an officer acting by authority of a revenue law.” *Carico v. Wilmore* (D. C.) 51 Fed. 196. And the petitioner—as he was acting under such an officer—is within the intent and letter of the statute (*Davis v. South Carolina*, 107 U. S. 597, 2 Sup. Ct. 636, 27 L. Ed. 574) if the prosecution is on account of an act done under color of office or of any revenue law, or if the prosecution is on account of any right or authority claimed under any revenue law. Possibly the mere fact that the assault made by Thomas on the petitioner grew out of the prior actions of the petitioner while acting under the deputy revenue collector may have no bearing on the question here. If, years after a revenue collector has left the government service, he is attacked because of some act done by him while in the service, and if, in repelling the attack, he kills the one who assaults him, his act is not one done under color of office or of any revenue law, nor is it an act done under a right or authority claimed under any revenue law. The only right that could be claimed in such case would be the right of self-defense. Again, suppose that a revenue officer, while holding a commission,

but while quietly at his home, and while not engaged in any official duty, is attacked because of some act previously done by him in the performance of his official duty, and in repelling such attack he kills the person who assaulted him, and is indicted therefor in the state court. It would seem that the act of killing here is not done under color of office or of any revenue law, nor under a right properly to be claimed under any revenue law; but that the officer in this case is again merely exercising the right of self-defense. While congress might well have extended the right of removal to cover such a case, the language employed in section 643 may not be quite sufficient to do so. *Illinois v. Fletcher* (C. C.) 22 Fed. 778. However, the petition here sets up certain other facts which I think do show a prima facie right to a trial in this court. These facts are that, the petitioner having been duly summoned as a posseman by a revenue officer, who was "seeking to arrest" an offender against the revenue law, and while the petitioner was "in the discharge of such duty" he was set upon by Thomas, who declared his purpose to kill petitioner, and the latter in self-defense struck said Thomas. If a revenue official (the law being the same in the case of one acting under such official as his posseman), while "hot-foot" after a fleeing violator of a revenue law, is set upon by friends of the fugitive, who seek thus to prevent the arrest, and if, in resisting the assault, the officer kills one of the party, his act in so doing is certainly one done under color of office, or one done under a right claimed under a revenue law. "Colorable" is defined as "having the appearance, especially the false appearance, of right." In the case supposed it was the duty of the officer to arrest the fugitive. To execute this duty he had to repel the assault, or to abandon his pursuit. The killing, then, was, to say the least, done colorably in the line of official duty. Does it alter the case if we suppose that the person or persons who interfere with the officer's pursuit are actuated, not by a desire to prevent the arrest, but by a mere personal desire to injure the officer? In such case, if the assault be not repelled, the officer cannot proceed with the execution of his official duty. Consequently it is not a strained construction of the statute to hold that when an attack is made on a revenue officer, while he is in the actual pursuit of a violator of the revenue laws, by a third party actuated by mere personal malice towards the officer, and the officer, in repelling the attack, wounds or kills the person attacking him, such act is one done, at least colorably, in the line of official duty. Nor can a distinction be properly drawn if, instead of being in actual pursuit, the officer is merely on the way to make an arrest, or merely seeking an offender with intent to arrest him when found. It seems to me that it is as much the officer's right, even if not as much his duty, to proceed on his way, or to proceed with his search, as it is to pursue when the offender is in sight and is fleeing. If interrupted by one who assaults him—no matter what cause actuates the person making the assault—the officer has as much right to repel the assault in the one case as in the other. To be sure, the same necessity for immediate action may not exist in both cases. It is true that, when the officer is merely traveling on

the way to make an arrest, he could, perhaps, by a timely retreat, avoid the necessity of injuring the one attacking him. But this might also be true if he were attacked while in hot pursuit of a fleeing criminal. And in either case his act in repelling the assault is at least colorably done in the exercise of his official duty; for in either case it is his official duty to proceed, whether with the actual pursuit of a fugitive, or with his journey, or his search for an offender. Any one who, while the officer is thus engaged, attacks him, is, in some measure, interfering with the performance of an official duty. And in repelling the attack the officer is at least colorably performing such duty. The mere fact that the officer's chief thought or sole thought is self-defense does not eliminate from the case the fact that in repelling the assault he is, at least colorably, proceeding with his official duty. And I am not disposed to emasculate the statute by such refinements as making the right of removal depend on whether the thought uppermost in the officer's mind was self-defense, or an intent to proceed with the execution of his duty—necessarily putting his assailant hors de combat, in order that he might be at liberty to so proceed. The intent of section 643, Rev. St. [U. S. Comp. St. 1901, p. 521], is to afford to revenue officials and their assistants protection from local prejudice against federal revenue laws and revenue officials. The language of the statute does not authorize a removal of every prosecution against a revenue officer; but the words "under color of" and "right or authority claimed" show clearly that the act for which the prosecution is commenced need not be one done strictly in pursuance of a federal revenue statute in order to justify removal. If, for instance, a revenue officer, while not even colorably engaged in the performance of duty, sets fire to a neighbor's dwelling, he should be tried for his arson by the state court. But if, while seeking to arrest a violator of a revenue law, who is fortified in his dwelling, the officer—even without sufficient justification—sets fire to the house in order to effect the capture, the trial of the charge of arson made against him should be removed to the federal court.

The conclusion I reach is that the petition here shows on its face a right of removal. The motion to remand is overruled.

ALBRO v. MANHATTAN LIFE INS. CO.

(Circuit Court, D. Massachusetts. December 23, 1902.)

No. 1,247.

1. LIFE INSURANCE—PLACE OF CONTRACT.

The answer in an action on a life insurance policy admitted that the defendant was legally admitted to do business in Massachusetts; that the policy in suit was issued on an application made in writing to its

¶ 1. See Insurance, vol. 28, Cent. Dig. § 174.

agent in that state where the applicant resided, and was there delivered to the applicant by such agent, to whom the first premium was paid. *Held* that, in the absence of other facts, the policy was a Massachusetts contract.

2. **SAME—LAW GOVERNING CONTRACT—EFFECT OF PROVISIONS IN POLICY.**

Where a contract of life insurance is in fact made within a state between a resident thereof and a foreign insurance company legally authorized to do business therein, the parties cannot avoid statutory provisions of the state, declaring a rule of public policy with respect to such contracts made within its jurisdiction, by inserting provisions in the policy adopting the law of another state.

3. **SAME—MASSACHUSETTS STATUTE—REQUIRING ATTACHMENT OF CORRECT COPY OF APPLICATION TO POLICY.**

Under the statute of Massachusetts (Acts 1894, c. 522, § 73) providing that, unless a correct copy of the application is attached to the policy, the same shall not be considered a part of the policy or received in evidence, an application cannot be admitted in evidence as a defense to an action on the policy where the copy omitted the answers made by the applicant to certain questions, which appeared in the original, and which under some circumstances might affect the rights of the parties, although they have no bearing on the questions raised by the pleadings.

4. **SAME—RULE OF EVIDENCE IN FEDERAL COURTS—FOLLOWING STATE DECISION.**

In construing such statute the supreme judicial court of Massachusetts laid down the rule that, where under its terms the application itself was not admissible in evidence, the company could not be permitted to show by oral evidence statements made by the insured which were contained in the application, and such rule has been acquiesced in without question for a number of years. *Held* that, without regard to its correctness, such rule was binding upon a federal court sitting within the state.

At Law. Action on life insurance policy. On demurrer to answer. John W. Cummings, for plaintiff. Crapo, Clifford & Clifford, for defendant.

PUTNAM, Circuit Judge. The question now before us arises on the following portion of section 73, c. 522, Acts Mass. 1894, namely:

"In any claim arising under a policy which has been issued in this commonwealth by any life insurance company, * * * the statements made in the application as to the age, physical condition, and family history of the insured shall be held to be valid and binding upon the company: provided, however, that the company shall not be debarred from proving as a defence to such claim that said statements were wilfully false, fraudulent or misleading: and provided, further, that every policy which contains a reference to the application of the insured, either as a part of the policy or as having any bearing thereon, must have attached thereto a correct copy of the application, and unless so attached the same shall not be considered a part of the policy or received in evidence. Each application for such policy shall have printed upon it in large bold faced type the following words: 'Under the laws of Massachusetts; each applicant for a policy of insurance to be issued hereunder is entitled to be furnished with a copy of this application attached to any policy issued thereon.'"

With reference to the construction of this statute and its application to this case, the counsel on either side have cited a number of

¶4. Federal courts following state practice as to rules of evidence, see note to *O'Connell v. Reed*, 5 C. C. A. 594.

decisions. We have examined them all, but refer only to such of them as seem to us important.

The general history of the legislation which led up to this enactment, and the fact that the part of it with which we are concerned applies to all policies governed by the law of Massachusetts which contain references to the application within its language, were explained in *Considine v. Insurance Co.*, 165 Mass. 462, 43 N. E. 201.

The question before us arises as follows: The plaintiff declared on a policy issued by the defendant corporation. The defendant filed an answer containing four independent paragraphs, the first and second of which rely directly on misstatements contained in the application on which it is alleged the policy issued, and also they allege that a correct copy of the application was attached to the policy as provided by the statute to which we have referred. The third paragraph adopts the first and second paragraphs, and alleges that the delivery of the policy was obtained by willful fraud in the answers made in the application already referred to. The fourth paragraph in like manner adopts the first and second paragraphs, and alleges that the statements in the application referred to were false, fraudulent, and misleading, and that the truth in reference thereto would have increased the risk of loss, so that thereby, and by the express terms and conditions of the policy, no contract of insurance binding on the defendant was made.

There is no allegation in the answer, or in the amendment thereto, to which we will refer, charging fraudulent statements, except statements in the application itself. By an amendment to the answer the defendant admitted that the copy of the application annexed to the policy was incorrect in leaving blank statements as to the age of the applicant's mother's mother, her health, and the cause of her death. The blanks in the application which according to the copy had not been filled were, in fact, filled with facts which were favorable to the applicant, but which the answer admits were truly stated. Therefore there is nothing in these omissions from the copy of the application which appertain to anything which could injuriously affect the rights of either party as the case is now presented.

The plaintiff demurred to the answer, assigning, among other reasons of demurrer, that it appeared thereby that no correct copy of the application was annexed to the policy.

The answer admits that the applicant lived in Massachusetts; that the defendant is a life insurance company legally admitted to do business in that state; that the application for the policy was made in writing to the representative of the defendant corporation at Fall River; that the defendant did issue to the applicant its policy of insurance by manual delivery thereof at Fall River by the defendant's agent to the applicant; and that the first premium was paid by the applicant to the defendant's agent, also at Fall River.

Beyond the matters which we have stated, there is nothing in the pleadings to show that the contract for insurance was not completed within Massachusetts. Notwithstanding this, the defendant argues that the contract was completed in New York, and that the usual provisions of life insurance policies, which are found in this policy,

that the contract should not go into effect until the policy had been delivered and the premium paid, relate only to the *punctum temporis* when the insurance is to commence. It is true that a contract of insurance might be made which would be in all respects binding on the parties, although the policy would not become effective—that is to say, the insurance would not begin to run—until the policy had been delivered and the first premium paid, one or both. Indeed, even in this case, it is not impossible that a binding oral contract for this insurance, valid in the law against both parties, might have been made in the state of New York, but on such terms that the insurance should not become effective until the policy was delivered and the first premium paid. Oral agreements for insurance have been enforced, alike at law and in equity, even though no policy had been delivered and no premium paid. Nevertheless there is nothing in the pleadings in this case to sustain any proposition of this character on the part of the defendant, and, on the face of the record, the case is a clear one of a contract for life insurance made in Massachusetts between a foreign corporation, admitted to do business therein, and a resident of Massachusetts, with a delivery of the policy and a payment of premium all taking place within the same state.

Such being the fact, the statute to which we have referred must be accepted as a law which governs this contract from motives of public policy. That such statutes, and that the application of them to contracts in Massachusetts, are valid and must be recognized by all courts is too well settled to need discussion. Nevertheless, the defendant insists that, inasmuch as there are some provisions in this policy which adopt the law of New York, and as also the policy was payable in New York, the statutory provision which we have cited does not apply. Defendant puts the case on the ground that parties making contracts may, under some circumstances, agree for the law of a state or country foreign to the place of contract. As a general principle, this cannot be disputed; but also clearly it has no application where the result thereof would be to accomplish an evasion of statutory provisions declaring a rule of public policy with reference to contracts made within the jurisdiction where the legislation is enacted. Exceptions seem to have been made in reference to usury statutes, and perhaps to some other peculiar legislation, but such instances do not furnish the rule.

Therefore, under the first and second paragraphs as amended, the only question which can arise is whether the copy of the application is a correct one, within the meaning of the statute. Within the ordinary interpretation of the word "correct," it is not. The case is not one of idem sonans, nor of the omission of letters, nor of parts of a word, nor of any error where what is left raises a reasonable presumption what the original was. It involves omissions of entire words under such circumstances that the legal effect of the application according to the copy would, under some circumstances, be different from its effect as actually drawn. Under those circumstances, no judicial tribunal has a right to say that the statute does not apply, even though the errors may not relate to matters which are essential to the substantial rights of the particular parties in issue. If the court undertakes in this

way to transgress the language of the statute, where can it stop, and by what rule can it determine the extent of its powers in that direction? Not only are we clear on this from the necessary rules of legal construction, but our conclusions are entirely in harmony and fully sustained with and by the reasoning and conclusions of the supreme judicial court of Massachusetts in *Nugent v. Association*, 172 Mass. 278, 52 N. E. 440. Therefore, so far as these two paragraphs are concerned, it seems to us clear that the demurrer to the answer must be sustained.

With reference to the third and fourth paragraphs of the answer: As we have already observed, each makes the application specifically a part of the pleading. Therefore, on strict rules, they necessarily follow the fate of the first and second paragraphs. Nevertheless, this is, perhaps, too narrow a disposition of them, because they could easily be amended to raise the question which the parties evidently intend to raise, and which is involved in an observation made by this court, as now constituted, at the trial of *Hadley v. Society*. What was then said has never been reported, but is referred to in the same case on appeal. 102 Fed. 856, 860, 861. That observation was with reference to the rule given at page 466, 165 Mass., and pages 202, 203, 43 N. E. *Considine v. Insurance Co.*, 165 Mass. 462, 43 N. E. 201, already referred to. This court then considered that it would hesitate before it concluded that we are bound by a rule of evidence which might compel us to sit here and see a gross fraud committed upon an insurance company, without ability on our part to furnish relief against it, because, although a paper might not come in properly as an application in the sense that it is to be treated as a warranty, it may yet contain representations which, as representations, operate as a gross fraud on the underwriting corporation. We added that we were not prepared to say that a federal court, notwithstanding the decision in *Considine v. Insurance Co.*, "must sit here and exclude, not only the application, but the testimony of the parties who heard the statements made, as to what was said, and thus permit a gross fraud in that way to be accomplished against an insurance company."

The rule stated in *Considine v. Insurance Co.* had reference to the statute in question here, and to an application a copy of which had not been attached to the policy, and the opinion of the court observed as follows:

"The application in each case not being admissible in evidence, the defendant was rightfully refused permission to show by oral evidence what was said by the insured at the time of his examination by the company's agent, the examining physician, all of which was contained in the application."

In support of this two earlier cases were cited, neither of which arose under the statute in question. This is all that was said on the topic; and, certainly, it is not a very satisfactory disposition of a statute which, having been passed for the purpose of helping out inattentions or misapprehensions on the part of persons insured, then enables such persons to foreclose, without any possible relief for the underwriters, remedies against the grossest fraud, which occasionally, if not in many cases, might be proved clearly by oral testimony without the aid of the application. The statute provides that the

application itself shall not be received in evidence, but it makes no mention of proof of conversations to the support of which the application is not essential; and the general rule with reference to the exclusion of oral testimony has no relation to papers of this character. Nevertheless, the decision in *Considine v. Insurance Co.* seems never to have been questioned in Massachusetts, and it has been acquiesced in now for a number of years as the undoubted rule of evidence in that state. Defendant in this case saw fit to enter the state and transact business there under a statute which had thus been interpreted. Being, therefore, a rule of evidence arising out of the construction of a local statute, acquiesced in in Massachusetts, we are compelled, notwithstanding our doubts expressed on the previous occasion, to the reluctant conclusion that, as a rule of evidence, it controls this court within the district of Massachusetts. Therefore we are unable to see any manner in which the defendant can take advantage of any of the propositions which it sought to raise by its answer.

There will be a judgment that defendant's answer is insufficient in law, and that the plaintiff's demurrer is sustained, with also judgment for the plaintiff for the amount of the policy, interest, and costs.

THOMPSON et al. v. SCHENECTADY RY. CO. et al.

(Circuit Court, N. D. New York. January 3, 1903.)

1. EQUITY—BILL IN NATURE OF BILL OF REVIEW—WHEN APPROPRIATE REMEDY.

Where the rights of persons who were not parties to a suit in equity are affected by the decree entered therein, and they seek to obtain a modification of such decree by setting up matters which occurred pending the suit, but which were not presented to the court, the proper practice is by the filing of a supplemental bill in the nature of a bill of review.

2. SAME—LEAVE TO FILE—NOTICE OF APPLICATION.

A supplemental bill, after decree, in the nature of a bill of review, cannot be filed without leave of court, but it is discretionary with the court whether to require notice to the defendants therein, or the parties to the decree, before granting such leave.

3. SAME—SUFFICIENCY OF BILL.

A bill by property owners on a street for the modification of a decree entered by the court in a suit to foreclose a mortgage on the property and franchise of a street railroad company, to which complainants were not parties, so as to recognize and conform to an agreement made pending such suit between the receiver therein and complainants, and confirmed by the city council, for the permanent abandonment of a portion of the line of road covered by the mortgage, which was carried into effect by the removal of the track and the restoration of the pavement on the street in front of complainant's property. *Held* to show such equity in complainants as entitled them to a hearing on the merits.

In Equity.

This is an application for an order vacating an order of Mr. Justice Wallace granted July 1, 1902, which order granted leave to file the bill of complaint herein, and also striking such bill of complaint from the files of the court. On the 1st day of July, 1902, Mr. Justice Wallace made an order granting

¶ 2. See Equity, vol. 19, Cent. Dig. §§ 588, 1110.

leave to the complainants herein to file their bill of complaint, and pursuant to such order the complainants filed their bill, and on the 8th day of September following filed their amended bill of complaint.

Hun, Johnston & Hand, for the motion.
Edward Winslow Paige, opposed.

RAY, District Judge. The affidavit of Hinsdill Parsons, president of the defendant herein Schenectady Railway Company, states the grounds on which the application to vacate is made as follows:

"The ground of the application is that no notice was served of the application for leave to file the bill as required by law, and that the bill is an improper bill of review, and does not state facts constituting any equity in the plaintiffs, and should not be allowed to be filed as a bill of review in its present form."

On the argument, and in the brief for the defendants, it is urged that the order granting leave to file the bill was improperly granted because not founded on a petition or affidavits. No such point or claim is made in the moving papers, and it is only necessary to say that, the point not having been presented there as a ground for vacating the order, it will not be considered here further than to say it is presumed in the absence of proof that Justice Wallace acted on either a petition or affidavits in the nature of a petition. The affidavit of Mr. Parsons further states, in substance, that the subject-matter of these actions has already been presented in seven actions for injunctions in the supreme court in the state of New York (77 N. Y. Supp. 889), and that such actions are now at issue, and that such matters have already been presented to such court in applications for temporary injunctions restraining the defendant Schenectady Railway Company from operating its roads. The affidavit then goes on to deny some of the material allegations of such bill of complaint. The amended bill of complaint alleges the ownership or possession and occupation by the complainants, respectively, of certain lots of land on Washington avenue, in the city of Schenectady, and further states how such title was derived; that the Schenectady Street Railway Company was incorporated about February 24, 1886, and, having obtained certain consents specified, it constructed a horse railroad on State street, and from the westerly end of State street northerly along Washington avenue, passing in front of the places of the complainants Thompson, Beattie, the Pecks, the complainants Lansing and Whitmyre, and the respondent Paige, but not going as far north as the southerly line of the premises of the complainant Vrooman, nor in any way in front of or passing any of the premises of the complainants Vrooman and Van Epps; that until July 2, 1891, said company operated the said railroad with horse cars in the summer and sleighs in the winter; that on the 2d day of July, 1891, having the consents mentioned, it changed to an overhead trolley and operated the railroad very irregularly with electric cars in the summer and sleighs in the winter, until it ceased the operation of the road as stated in such bill of complaint. It is then alleged that said railroad company made a mortgage to the Central Trust Company of New York on the 1st day of September, 1891, to secure the bonds

therein described, and gives the boundaries of the property so mortgaged; that August 15, 1893, one Williams filed in the circuit court in the United States of the Northern district of New York a bill against the said railway company, and that one John Muir was duly appointed receiver of said railway company, and entered into the possession of all its property. The bill of complaint then sets out a petition made by said receiver and the manager of said railway company, praying, in substance, that the running of cars over the portion of the said street railway lying between the easterly side of Church street and Washington avenue and on Washington avenue from its intersection with State street to the Mohawk river bridge, be dispensed with until June 1, 1894, and that the running of the railroad on Washington avenue was then discontinued, and has not been resumed, except as hereafter stated; that authority was given to said railway company to discontinue the running of cars from Church street through State street to Washington avenue until December 1, 1894, and then states that on or about December 14, 1893, the said trust company of New York filed its bill of complaint against said street railway company for the foreclosure of said mortgage, and that June 19, 1894, one George W. Jones was duly appointed receiver in said action. The bill then alleges, in substance, that said receiver and the property owners on Washington avenue applied in October, 1894, to the common council of the city of Schenectady to have the running of cars at and on Washington avenue at places specified permanently discontinued, the track removed, and the pavement relaid, and it was stated in said application: "It is understood and agreed that this action of the common council and of the street railway company is not in any way to prejudice or affect injuriously the franchise or any of the rights of said street railway company except as to the running of its cars from Church street down to the Mohawk bridge." "The common council then adopted a resolution authorizing the railway company to dispense permanently with the operation of the road between Church street and Mohawk bridge on condition that the track on said portion of said streets be promptly removed, that the pavement on said portion of Washington avenue be restored, and that the said receiver reimburse the contractor now repaving the said portion of State street for any extra expense for labor and material incurred by said contractor by reason of the removal of said track." In all other respects the license of the Schenectady Street Railway Company to be and remain unchanged and in full force. This resolution was approved by the mayor the same day. The track of said road on Washington avenue and Church street was then taken up, and the pavements restored. This, it is alleged, was done by George W. Jones, as such receiver, and there has been no railroad or track there since, except as hereafter stated. The amended bill of complaint then alleges, in substance, the decree of sale in said foreclosure action, the sale of the mortgaged property to Kobbe, White, and Batchellor, the deeds given by the special master and by the receiver and the Schenectady Street Railway Company, containing the same descriptions contained in the mortgage. The receiver made a report, and from same and accompanying papers it appears that he turned

over the mortgaged property to the defendant the Schenectady Railway Company. It is also alleged that said defendant knew of such agreement to the abandonment of the road on Washington avenue.

Omitting certain allegations as to suits in the supreme court of the state of New York, none of which are *res judicata* as to the relief sought by this action, it appears from the amended bill of complaint that the Schenectady Railway Company was organized by said Kobbe, White, and Batchellor under the aforesaid sale of the mortgaged property and the laws of the state of New York, and that it in April, 1902, began to tear up Washington avenue and lay tracks there, relying upon the original consents of property owners to the construction of the original road, and which, as to certain parts thereof, was abandoned, as before stated. The prayer for relief is, in substance, that the decree of this court in such foreclosure action be reviewed and revised so as to omit from the description of the property therein Washington avenue, and that it be decreed that the agreement made between said Jones, as receiver, said property owners, and the city of Schenectady be and was assented and agreed to by all the property owners, by all the bondholders, by the Central Trust Company, by the Schenectady Street Railway Company, by the purchasers of such sale, and by the defendant the Schenectady Railway Company, and that same be approved by the court, and made binding on all the parties and all the world. Also that said defendant be restrained temporarily, and then by final decree, from building or operating its road on Washington avenue, etc.

The complainants in this action were not parties to such foreclosure. This action is in the nature of a motion to open the decree in that action, and be made parties to that foreclosure action, and permitted to set up the said agreement made during its pendency as to the abandonment of the road on Washington avenue. It is not shown that these property owners had actual notice of such proceeding, or of such decree, or of such deeds, or of any purpose on the part of the new company—really the purchaser at the sale—to disregard the said agreement and reconstruct the road or construct a new one on the strength of the consents to the establishment and operation of the original road. The respondent herein, the Schenectady Railway Company, has no equitable right to construct and operate a road on Washington avenue if it knew of the agreement mentioned, and its full execution, when organized. Having a decree of this court conveying to it all the mortgaged property, it is protected thereby; and it is claimed that, if this action cannot be maintained, then the property owners on Washington avenue are without remedy, and must submit to have this railroad in front of their premises, notwithstanding such agreement, which it is claimed was mutual, and based on good and sufficient considerations. This is a supplemental bill in the nature of a bill of review, and to a certain extent, and as to the parties named herein, an original bill in a new suit. It is a bill filed by new parties, whose rights and interests are affected by the decree made in the foreclosure action, and who seek to set up important and material matters which occurred during the pendency of that action, and which new matters are directly connected with the subject-matter of such

action. "When an event happens subsequently to the filing of an original bill, which gives a new interest in the matter in dispute to any person, whether or not already a party, without depriving all of the original plaintiffs suing in their own right of their interest, the defect arising from this event may be supplied by a supplemental bill." 1 Fost. Fed. Prac. p. 409, § 187. "A supplemental bill may be filed at any time during the progress of a suit, as well after as before a decree, and even during the pendency of an appeal." *Id.* p. 412, § 188. A defendant may file a supplemental bill, but not a supplemental statement. 2 Daniell, Ch. Prac. p. 1530, note 5; *Lee v. Lee*, 9 Hare, App. 91. May not file supplemental statement. *Lee v. Lee*, 10 Hare, App. 72. May file supplemental bill. 17 Jur. 272; *Lys v. Lee*, 4 De Gex, M. & G. 219; 17 Jur. 607; *Berrow v. Morris*, 10 Beav. 437. "A supplemental bill may be brought on behalf of the defendant in the suit." *Morrison v. Searight*, 4 Baxt. 479; *Standish v. Radley*, 2 Atk. 177; *Earl of Portsmouth v. Lord Effingham*, 1 Ves. Sr. 430. See *Baker v. Whiting*, 1 Story, 232, 233, Fed. Cas. No. 786, citing cases; *Berrow v. Morris*, 10 Beav. 437. A supplemental bill must not be confounded with a supplemental statement, which can only be filed by the complainant. The authorities are clear that, when new parties must be brought in, or the new matter is brought forward by persons not parties to the original suit, but whose rights and interests are affected by the decree already made, and who seek to set up matters which occurred during the pendency of the action, the filing of a supplemental bill in the nature of a bill of review is the proper practice. When a supplemental bill, after decree, makes a new case, or impeaches or is inconsistent with the decree, it becomes a bill of review, or a supplemental bill in the nature of a bill of review, and cannot be filed except with leave of the court. 2 Daniell, Ch. Prac. (6th Am. Ed.) 1536, note. Here leave has been granted. It was discretionary with the justice to whom the application to file this bill was made whether or not to require notice to the defendants in the supplemental bill and to the parties to the original action. *Lee v. Lee*, 4 De Gex, M. & G. 222, 223; *Henry v. Insurance Co. (C. C.)* 45 Fed. 303. No rule requires notice in such a case as this. It is not sought in this action to change the whole of the decree in the foreclosure action, but only so much thereof as, it is alleged, ought not to have been granted, and would not have been granted had the present complainants been parties thereto, with an opportunity to set up and prove the facts as to the agreement mentioned and the proceedings in execution thereof. In *Berrow v. Morris*, 10 Beav. 437, when a defendant filed a supplemental bill in the nature of a bill of review, the court said:

"The only question is whether she has taken the proper course by filing this bill. It is objected that it is a supplemental bill in the nature of a bill of review, which ought not to be filed without the leave of the court. There is something very plausible in the argument, because (as it is said), if every defendant is entitled to come and alter the account, it would lead to great inconvenience. I do not think it would lead to that result. There is a considerable difference between a plaintiff and a defendant coming, after decree, and asking additional relief against another defendant. The relief is necessarily additional to that already obtained, for to file an original bill would be idle, unless it were desired to alter the whole of the decree."

It may be said that there is a wider difference between a defendant and a stranger to the suit on the record not in interest, coming after decree for relief which he might have obtained in the original suit, but did not obtain because the parties thereto neglected to present to the court the facts upon which his equities rest. It would seem the filing of such a bill should be a matter of right. It is not intended to intimate any opinion as to the merits of the case, which can only be passed upon when the evidence is all in, and all the parties have been heard. In the suits in the supreme court of the state of New York the opinion of the learned justice at special term proceeded on the theory that the plaintiffs there and here had no title in the street (Washington avenue), and therefore no right to enjoin the tearing up of the avenue and the construction of a street railroad there. That question is not now before the court. It is, of course, necessary to pass on the question whether or not the amended bill, with all the exhibits, states facts, which, if not controverted, constitute any equity in the plaintiffs. If, during the pendency of that foreclosure, the agreement alleged was made by the persons and parties named, and executed and acted upon as claimed, and was known to and acquiesced in by the purchasers, and they then became, in effect, the defendant company, and it became the owner under and through the foreclosure sale, with full knowledge of the agreement, the ratification by the city, and the abandonment of the franchise and property as to Washington street, the plaintiffs have strong equity, and make a strong demand (whether sufficient or not is not now determined) for equitable relief. If all this be true, what was the effect upon the consents given by the property owners before any railroad was constructed on Washington avenue? Could the receiver make that agreement during the pendency of that action, execute it (and it must have been with the knowledge of the plaintiff in that action), and then, in equity, the parties proceed to sell and convey to the purchasers the right to reconstruct and operate a railroad on that avenue? Such right was covered by the decree made, and such right was sold and conveyed within the description of the property sold, but if all the allegations of the amended bill are true it would seem that there ought to have been an exception made of the abandoned right. It is not apparent that sections 13 and 103 of the railroad law have any application to this case.

The motion to vacate the order granting leave to file the bill and to strike the bill from the files of the court is denied.

In re COUNTRYMAN.

(District Court, N. D. Iowa, W. D. January 8, 1903.)

1. BANKRUPTCY—DISCHARGE—GROUNDS FOR REFUSAL.

A bankrupt cannot be denied a discharge because of a failure to schedule land which he conveyed three years before the passage of the bankruptcy act, unless it is clearly shown that he really owned the same or an interest therein at the time of the filing of the petition in bankruptcy. That the conveyance was without consideration, and that creditors might have subjected the land to their debts, is no ground for refusal of a discharge.

In Bankruptcy. On petition for discharge, and objections thereto. George H. Bliven and J. W. Hallam, for bankrupt. Sullivan & Griffin, for creditors.

SHIRAS, District Judge. From the evidence submitted in this case it appears that in October, 1888, the title to 80 acres of land in Woodbury county, Iowa, passed to the bankrupt by a deed from one G. D. Pence. In October, 1895, the bankrupt conveyed the title to this land to her husband, Lewis Countryman. On August 29, 1902, Mrs. Countryman was adjudged a bankrupt on her own petition, and, upon the filing by her of a petition for discharge, three of the creditors filed specifications in opposition thereto, on the ground that the debts due them were created while the title to the 80 acres was in the name of the bankrupt, that the transfer to the husband was made without consideration and in fraud of creditors, and that in fact the bankrupt is yet the owner of the property and should have scheduled the same as part of her estate, and that she failed to include the same in the list of her property.

The evidence shows that the land was conveyed by the bankrupt to her husband in 1895, nearly three years before the enactment of the bankrupt act. The only ground on which it could be possibly claimed that this transfer constitutes a reason for refusing the discharge is that in fact she retains an interest in the realty, of such a nature that she should have included the same in her schedules, for if, at the time the petition in bankruptcy was filed, she had no actual or valuable interest therein, the fact that she did not include the same in the schedules would not be sufficient reason for holding that she had made a false oath in connection therewith. The question is not whether the creditors, whose debts were created while the title of the land stood in her name, could not subject the land to the payment of their claims on the ground that the transfer to her husband was without consideration. As already stated, the conveyance of the realty to the husband was made in 1895, yet the creditors have not sought to enforce the payment of their claims against the land, either by independent action or through the trustee in bankruptcy. Under these circumstances, in order to defeat the discharge, it must be clearly shown that, when the petition in bankruptcy was filed, the bankrupt really owned the land or an interest therein, and this the evidence fails to show. The conveyance to the husband, even if it was not based upon a money or other valuable consideration, would be good between the parties, and would bar a claim thereto by the wife, unless it was shown that when the transfer was made she retained an actual interest therein. There is nothing in the evidence justifying the claim that she retained the ownership of the land, except testimony of statements made by her in 1896 to the effect that she still owned the land. This testimony as to these statements is denied by the bankrupt, and the evidence as a whole does not show that in truth the bankrupt made a false oath in swearing to the schedules, which did not include the land in question.

The discharge will therefore be granted, on usual terms.

KROEGHER v. CALIVADA COLONIZATION CO. et al.
 CALIVADA COLONIZATION CO. et al. v. KROEGHER.

(Circuit Court of Appeals, Third Circuit. December 26, 1902.)

Nos. 33, 34.

1. TRUSTS—PERSON ACTING IN FIDUCIARY CAPACITY—PURCHASE OF PROPERTY BY DIRECTOR AS AGENT OF CORPORATION.

A director of a corporation, who was appointed by a resolution of the board of directors on a committee to settle certain mortgages and claims against the corporation, and guaranteed in any "financial arrangements" he might make for the purchase of such claims, acted in that behalf not merely as a director, but as an agent and trustee for the corporation, and cannot claim for himself the benefit of reductions he secured in the adjustment and compromise of the claims, although he purchased the same with his own funds.

2. CORPORATIONS—ESTOPPEL—ACQUIESCENCE IN ASSERTION OF INVALID CLAIM.

Action of the directors and stockholders of a corporation showing a disposition or intention to recognize an unauthorized claim made by a director that he was entitled to be paid the face value of claims against the corporation which he had purchased at a discount as agent, and held in trust for its benefit, does not give validity to such claim, nor estop the corporation from denying his right.

3. DECREE—MATTERS CONCLUDED—FIDUCIARY RELATION BETWEEN PARTIES.

A director of a corporation, acting as its agent, purchased certain mortgages against its property at a discount in his own name, using his own funds. He afterward foreclosed the mortgages, and bid in the property at the sale under the decree. *Held*, that such decree, which was for the full amount of the mortgage debts, was not conclusive of his right to receive such amount from the corporation for his own benefit, since it was based on his legal title only, and no question relating to the fiduciary capacity in which he held the mortgages was presented to or determined by the court.

4. TRUSTS—PURCHASE OF PROPERTY BY TRUSTEE.

The rights of a director of a corporation, who purchased certain mortgages against its property with his own funds, but pursuant to a resolution of the board of directors which guaranteed his repayment, were not enlarged, as against the corporation, by his acquiring the title to the property through foreclosure; such title being held by him in trust for the corporation, subject only to his right to be repaid his actual outlay, with interest.

5. CORPORATIONS—UNPAID STOCK SUBSCRIPTIONS—ENFORCEMENT FOR BENEFIT OF CREDITORS.

A statutory provision that subscribers to the stock of corporations shall be required to pay deferred installments on their stock at such times as shall be determined by the directors, and that such payment may be enforced by action after certain notice of such calls has been given, does not affect the power of a court of equity in insolvency proceedings against a corporation to decree payment of such unpaid subscriptions for the benefit of creditors, although no call therefor has ever been made by the directors.

¶ 1. The power of officers and directors in their individual capacity to deal with corporation, see note to *Bensiek v. Thomas*, 13 C. C. A. 466.

¶ 5. Stockholders' liability to creditors in equity, see notes to *Rickerson Roller Mills Co. v. Farrell Foundry & Machine Co.*, 23 C. C. A. 315; *Scott v. Latimer*, 33 C. C. A. 23.

See *Corporations*, vol. 12, Cent. Dig. § 2269.

6. SAME — INSOLVENCY PROCEEDINGS — ADJUSTMENT OF ACCOUNTS BETWEEN STOCKHOLDER AND CORPORATION.

The receiver appointed in insolvency proceedings against a corporation filed a petition against one of the directors to obtain a conveyance to the corporation of property alleged to be held by such director in trust for its benefit. Such relief was decreed, and the matter was referred to a master to state an account of the amount due from the corporation to the director in respect to the trust. Pending a report thereon, a decree was entered in the main suit making an assessment on all stockholders for the amount of their unpaid subscriptions, for the benefit of creditors. *Held*, that it was competent and proper for the court, in entering a decree in favor of the director for the amount found due him from the corporation, to deduct therefrom the amount of his unpaid subscription, although such matter may not have been included in the special reference.

7. USURY—LAW GOVERNING CONTRACT.

An agreement made in good faith by a Colorado corporation to pay one of its directors 8 per cent. interest on advances to be made by him in purchasing liens on the corporation's property in Nevada, in consideration of such advances and his services in connection therewith, was valid, where such rate of interest was legal both in Colorado and Nevada, although it was not legal under the laws of Pennsylvania, where the contract was actually made.

Appeal from the Circuit Court of the United States for the Western District of Pennsylvania.

George B. Gordon, for W. C. Kroegher.

J. H. McCreery, for Calivada Colonization Co.

Before DALLAS and GRAY, Circuit Judges, and BRADFORD, District Judge.

BRADFORD, District Judge. These are cross appeals from a decree of the circuit court of the United States for the western district of Pennsylvania. Joseph W. Rapp filed December 30, 1899, a bill in equity in that court against the Calivada Colonization Company, a corporation of Colorado, averring the insolvency of that company, and praying for the appointment of a receiver. On the same day A. C. Hays was appointed receiver, and thereafter, January 18, 1900, he filed in the same court a petition in the nature of a bill for a declaration of trust against W. C. Kroegher, on which an interlocutory decree was made February 10, 1900, as follows:

"And now, February 10th, 1900, upon consideration of the averments contained in the petition filed by A. C. Hays, Receiver, on January 18th, 1900, the exhibits thereto attached and affidavits submitted therewith, and the affidavit of W. C. Kroegher, Respondent, and after argument of counsel, it is ordered, adjudged and decreed that a bond in the penal sum of Twenty thousand (\$20,000) dollars be executed by the Calivada Colonization Company, by A. C. Hays, its Receiver, in favor of W. C. Kroegher and with the American Surety Company, of New York, as surety, conditioned for the payment of the following sums by the said Calivada Colonization Company to the said W. C. Kroegher within ten (10) days after this court (or the proper Appellate Court, in case an appeal be taken) shall adjudicate the same to be due and payable, to wit:

1. All the indebtedness of every nature and kind of the said Calivada Colonization Company to the said W. C. Kroegher, together with interest thereon to the date of the payment.

2. Any advances made by the said W. C. Kroegher of moneys used in and about the operation, care and management of the ranch and store of the company in Nevada, and any taxes paid thereon while the said Kroegher has

been in possession of the said property, and also his reasonable expenses and counsel fees in and about the matter of the recent sheriff's sale of the property of the said company to said Kroegher.

The amounts due to the said Kroegher under the two preceding paragraphs to be settled and adjudicated by this court subject to the right of appeal.

3. To indemnify the said W. C. Kroegher of and from every liability of every nature and kind whatsoever incurred by him while in possession of the Company's ranch and store in Nevada.

It is further ordered and decreed that upon the filing of said bond, the said W. C. Kroegher be, and is hereby enjoined, inhibited and restrained from making any sale or disposition of the real estate described in the petition or of the personal estate conveyed to said Kroegher by said Calivada Colonization Company, except as hereinafter decreed, or from encumbering or in anywise interfering with the same.

It is further ordered, adjudged and decreed that the said W. C. Kroegher make, execute and deliver to the said Calivada Colonization Company a proper deed of conveyance transferring all his right, title and interest of, in and to the real estate lately belonging to the said Calivada Colonization Company and lately purchased by him at Sheriff's sale.

It is further ordered, adjudged and decreed that the said W. C. Kroegher make, execute and deliver a bill of sale to the said Calivada Colonization Company for all personal property now on the ranch in Nevada, and that the said W. C. Kroegher surrender possession of all said real and personal property to A. C. Hays, Receiver of said Calivada Colonization Company.

It is further ordered that upon delivery of said assignment and the surrender of possession, all liability of the said Kroegher to said company for an accounting as to his management of the ranch shall cease. The only matters left open for consideration and adjustment, under the further decree of the Court, being an adjustment of the difference between the cash actually received by W. C. Kroegher (if any) while in possession of said ranch, and the cash actually advanced or paid out by said Kroegher (if any) while in possession of the said ranch, being included in the second paragraph of this decree relating to the bond.

That an accounting be forthwith taken of the amount due and payable to the said W. C. Kroegher under the terms of this decree and of the bond hereinbefore recited, and the said matter be and is hereby referred to H. D. Gamble, Esq., as Master, to settle and adjust the account and report the same to the court."

The master filed his account and report April 13, 1901, in which he exhaustively considered the law and the evidence, finding that the Calivada Colonization Company was then indebted to Kroegher, including principal and interest, in the sum of \$12,073.54. After numerous exceptions had been taken on both sides to the master's report and considered by the court below, they were all overruled, and the report and account stated by the master were in all respects confirmed, and a final decree in accordance therewith was made July 16, 1901.

The Calivada Colonization Company was incorporated in January or February, 1895, and organized March 13, 1895. Kroegher became a stockholder thereof December 1, 1896, purchasing and receiving certificates for 2,000 shares of the capital stock of the company of the par value of \$1 each, for which he paid in cash \$500 and received credit on the books of the company for the balance, namely, \$1,500, as "stock commissions and sundries." He became a member of the board of directors December 17, 1896, and president of the company January 21, 1898, and continued president until November 14, 1898, when he resigned that office, but continued as a

director. Including the period of his presidency he was a director of the company continuously from December 17, 1896, until after the suit was brought in the court below. At the time when Kroegher became a stockholder of the company it owned certain real estate consisting of a ranch in Pahrump Valley, in Nye County, Nevada, which was incumbered by two mortgages, one executed by the company to Angus McArthur, and the other executed by the company to the Taylor Trust Company, a corporation of California. There were also a number of claims against the company which were subsequently reduced to judgment in Nevada in favor of William T. Craig, and sundry unpaid state and county taxes against the above mentioned real estate. At a meeting of the board of directors January 21, 1897, the following resolution was adopted:

"Resolved, That M. D. Hays and W. C. Kroegher be appointed a committee of two to go to the Pahrump, and that this company will guaranty to W. C. Kroegher in any financial arrangements he may make for the purchase of the Taylor and McArthur and other claims against this company."

Acting on this resolution Kroegher and Hays, the latter then being the president of the company, visited the ranch referred to in February, 1897, and Kroegher purchased and had assigned to himself individually the Taylor and McArthur mortgages, and also the Craig judgment, which had been recovered January 28, 1897. The principal sum due on the McArthur mortgage at the time of its purchase by Kroegher was \$3,000. The whole consideration for the assignment of this mortgage was \$2,500, which he paid with his own money. On the Taylor mortgage there was due at the time of its purchase by Kroegher the principal sum of \$2,400, together with interest amounting to \$348, making a total of \$2,748. For the Taylor mortgage Kroegher paid out of his own funds \$2,400, and settlement was made with Taylor for the accrued interest by the issuance or transfer to him of 500 shares of the capital stock of the company. The shares of stock thus issued or transferred, however, were not the property of Kroegher, and he was in no wise entitled to any credit, as between the company and himself, for such issue or transfer. There was due on the Craig judgment at the time of its purchase by Kroegher the principal sum of \$2,360.42, besides interest and costs. The whole consideration paid to Craig for the judgment was \$2,200, of which Kroegher paid \$1,440 with his own money and the company paid the residue. In the master's account Kroegher is allowed credit for \$2,500 paid for the McArthur mortgage, \$2,400 paid for the Taylor mortgage, and \$1,440 paid on account of the Craig judgment, together with interest on these several amounts. There is, however, no assignment of error relating to the credit allowed with respect to the Craig judgment. One of the principal questions on Kroegher's appeal is raised by the fifth and ninth assignments. They are as follows:

"Fifth. The Court erred in not sustaining the fourth exception filed to the report of the Master, said exception being as follows, to wit:

'Fourth. The Master erred in only allowing W. C. Kroegher the sum of \$2,400 as the principal of the R. B. Taylor mortgage, and the sum of \$2,500 as the principal of the A. McArthur mortgage.' * * *

Ninth. The Court erred in not sustaining the eighth exception filed to the report of the Master, said exception being as follows, to wit:

'Eighth. The Master erred in finding as a fact that there was such a trust relationship between the company and Kroegher at the time of his purchase of the Taylor and McArthur mortgages as to make him a trustee for this company.'

The two mortgages designated as the R. B. Taylor mortgage and the A. McArthur mortgage were those executed, as before stated, to the Taylor Trust Company and Angus McArthur respectively. These two mortgages and the Craig judgment having been assigned to Kroegher as above stated, he brought suit in Nevada against the company on the mortgages in July, 1898, obtaining judgment or a decree and an order of sale October 5, 1898. The McArthur mortgage was executed June 5, 1895, to secure payment of \$5,000, with interest at the rate of 8 per cent. per annum. Of the above amount \$2,000 had been paid before suit was brought, leaving, aside from interest, \$3,000 unpaid principal. The Taylor mortgage was executed July 15, 1895, to secure payment of \$5,900, with interest at the same rate. Of this amount \$3,500 was paid August 4, 1896, leaving, aside from interest, \$2,400 unpaid principal. The judgment or decree so obtained by Kroegher awarded payment to him of \$3,000, the unpaid balance of principal of the McArthur mortgage, together with interest thereon from June 5, 1895, and of \$2,400, the unpaid balance of principal of the Taylor mortgage, together with interest thereon from August 4, 1896, and also interest on the sum of \$5,900, the original amount of that mortgage from January 15, 1896, to August 4, 1896, the date of the above mentioned payment or credit of \$3,500. Kroegher also caused execution to issue on the Craig judgment and to be levied on the personal property of the company on the ranch. The real estate and personal property of the company respectively were advertised for sale under the order of sale and the execution, but, owing to certain negotiations between Kroegher and the company, sale was stayed by him in November, 1898. Subsequently, in August, 1899, both the ranch and the personal property thereon were sold at Sheriff's sale, under the decree or judgment on the mortgages and an alias execution on the Craig judgment, to Kroegher; he being the only bidder. It does not appear that he or any one for him paid anything in connection with his purchase at sheriff's sale, save the costs and other expenses incident to it, and for the full amount of these he has been allowed credit in the master's account. It is not claimed on the part of Kroegher that he at any time was the absolute owner, at law and in equity, of the ranch or the personal property thereon. It clearly appears from the evidence that in all his dealings with respect to the management of and acquisition of title to such real estate and personal property he acted as representative and agent of and trustee for the company and that, while he was entitled to be reimbursed for moneys expended and reasonable expenses incurred by him and to be compensated for his services in the performance of the duty he had assumed, he acquired as against the company no equitable title to or claim against any of the property, real or personal, save the right to be indemnified for his reasonable outlays and expenses and receive reasonable compensation for his

services. Indeed, Kroegher did not at any time before the filing of the petition of the receiver against him disclaim the fiduciary or trust relationship borne by him to the company. But it is urged on his behalf that in taking the assignment of February 15, 1897, and February 23, 1897, respectively, of the Taylor and McArthur mortgages, he was acting, not as agent of or trustee for the company, but solely in his individual and personal capacity and for his own benefit, so far as any profit might be realized from acquiring title to the mortgages by the payment of a sum of money less than the amount remaining due and unpaid on those securities. In his affidavit by way of answer to the petition of the receiver Kroegher says:

"There was no understanding or agreement or suggestion that I was buying these mortgages for the company; on the contrary, there was a distinct understanding that I bought them for myself, the only idea being that as I was interested in the company I would be more lenient with the company in the collection of the mortgages than the parties were that then owned them, as the owners at that time were insisting on immediate payment. * * * I explicitly deny that I bought any of these mortgages or judgments as agent of the company. I bought and paid for them with my own money."

We have failed to discover any evidence of an understanding or agreement on the part of the company, prior to the assignment of the mortgages to Kroegher, that he was to purchase them for himself or for his individual advantage. It has been held by the highest authority that one who is a director of a corporation is not by reason of that mere fact, under all circumstances, precluded from purchasing, holding and enforcing a valid claim against such corporation. But this proposition has no legitimate application to the case before us. Here Kroegher, when he took legal title to the mortgages and paid for them, was not only a director, but a representative or agent of the company, clothed by the resolution of the board of directors of January 21, 1897, with an express trust, voluntarily assumed by him, to make financial arrangements "for the purchase of the Taylor and McArthur and other claims against this company." While as director merely of the company he was an agent, rather than a trustee, in a technical or strict sense, on the facts disclosed he was clothed with a superadded character of trustee. The resolution was adopted for the benefit of the company, and not to enable Kroegher to secure for himself personal profit at the expense of the company or in fraud of its creditors and stockholders. In purchasing and taking title to the mortgages, whatever may have been his intention or understanding, he must be held by a court of equity to have acted not merely as director but strictly as agent and trustee; and the relinquishment by the assignors of a portion of their claims against the company by the procurement of Kroegher did not furnish any ground on which he could base a valid claim against the company for the portion of the indebtedness so relinquished. The language employed by Mr. Justice Field in delivering the opinion of the Supreme court in *Wardell v. Railroad Co.*, 103 U. S. 651, 26 L. Ed. 509, is peculiarly apt in this connection. He said:

"It is among the rudiments of the law that the same person cannot act for himself and at the same time, with respect to the same matter, as the agent of another whose interests are conflicting. * * * The law, therefore,

will always condemn the transactions of a party on his own behalf when, in respect to the matter concerned, he is the agent of others, and will relieve against them whenever their enforcement is seasonably resisted. Directors of corporations, and all persons who stand in a fiduciary relation to other parties, and are clothed with power to act for them, are subject to this rule; they are not permitted to occupy a position which will conflict with the interest of parties they represent and are bound to protect. They cannot, as agents or trustees, enter into or authorize contracts on behalf of those for whom they are appointed to act, and then personally participate in the benefits."

This is not the case of a trustee to sell, purchasing on his own account the subject matter of the trust. There the transaction is voidable in equity, and will be set aside on reasonable objection taken by the proper party. This is a much stronger case. It is the case of a trustee for a corporation, empowered to adjust and compromise claims against it, who seeks to secure for himself the amount of the reduction involved in such adjustment or compromise. It discloses an attempted appropriation by the trustee, for his own personal use, of the precise thing which as trustee he was bound to secure for the benefit of the company. The fact that it may have been advantageous to the company to have the mortgage claims in friendly hands could not justify an assertion by Kroegher of any right to the amount of the reduction. That he should be friendly to the company of which he was a director was to be expected; but his friendliness could afford no excuse for failure by him as trustee fully and faithfully to observe and secure the interests of the company in the matters committed to him. It is contended, however, that the directors and stockholders of the company, after the assignment to Kroegher of the two mortgages in February, 1897, recognized a right on his part to receive on his own account not only what he paid for them out of his own funds but the excess of the whole unpaid indebtedness of the company thereon over and above the amount so paid by him. The recognition of a right implies its existence. If an asserted right be non-existent, mere recognition cannot convert it into an actuality. Something more is necessary to produce such a result. It is true that Kroegher's testimony and certain book entries and documentary evidence in the case tend to show an understanding or intention on the part of the directors and stockholders of the company, after he had acquired title to the mortgages, that he had or should have a right such as he now asserts. But the evidence does not disclose any facts on which under established principles of law or equity such understanding or intention, if it was entertained, could be held compulsory on the company to confer such a right or to estop the company from denying its existence. On the assumption that the company had authority, as against its creditors, voluntarily to dispose of a portion of its assets to Kroegher,—a point we do not now decide,—it made no such disposition. What Kroegher now claims was not the subject matter of a gift by the company; for there was no delivery. Nor was there any contract on sufficient consideration between the company and Kroegher creating any such right as he now asserts. Nor has the doctrine of ratification any application in this connection.

It is further contended on the part of Kroegher that the Nevada

decree or judgment obtained by him on the mortgages in October, 1898, conclusively established his right to receive on his own account the full amount of the principal and interest included therein. This contention clearly cannot be sustained. While that decree or judgment conclusively ascertained the amount of the unpaid indebtedness of the company on the mortgages and established the right of Kroegher to recover the same, it did not determine the capacity in which he should hold or dispose of the decree or judgment or its proceeds. He recovered on the strength of his legal title. No question of his fiduciary relation to the company was raised or entered into the case. The fact that he recovered in his own name and ostensibly in his individual capacity was in nowise inconsistent with the obligation resting on him to deal with the judgment or decree as trustee for the company. Had its property been purchased at a judicial sale under the judgment or decree by a third person at a price exceeding the costs and the sums paid by Kroegher for the mortgages with interest on his expenditure, and had the purchase money been received by him, it would have been his duty and he would have been liable as trustee to account to the company for the amount of the excess. Nor were his rights growing out of his purchase of the mortgages or his recovery thereon in any manner enlarged, save as to the amount of costs and expenses, through his taking title to the ranch at sheriff's sale in August, 1899. He acquired such title as trustee for the company, and without the payment of any consideration, aside from costs and expenses for which he has received credit. The property held by him in trust for the company having, pursuant to the interlocutory decree of the court below, been transferred to the receiver, Kroegher, so far as the mortgages and the proceedings thereon are concerned, is entitled, aside from interest, to receive only the sums paid by him as purchase money and to be reimbursed for the amount of his expenditures by way of costs and expenses. The fifth and ninth assignments of error, and also the sixth, based on the disallowance to him of "the full amount of the Taylor and McArthur mortgages, as adjudicated by the courts of Nevada", must, therefore, be overruled.

Another important question on Kroegher's appeal is presented by the first and eighth assignments of error. It is sufficient to refer to the latter, which is as follows:

"Eighth. The Court erred in not sustaining the seventh exception filed to the report of the Master, said exception being as follows, to wit:

'Seventh. The Master erred in allowing the Calivada Colonization Company a credit of \$1,500 for an alleged balance of subscription to capital stock of the company.'

Kroegher subscribed and received certificates for 2,000 shares of the capital stock of the company of the par value of \$1 each, and for them paid only \$500. No consideration whatever moved from him for the remaining seventy five per cent. of their par value. The sum of \$1,500 representing the unpaid amount of his subscription "went", in the language of the witness Agnew, the secretary of the company, "into profit and loss under the guise of a stock commission." Unpaid balances of subscriptions to capital stock of a corporation constitute a trust fund for the payment of claims of its cred-

itors. The statutes of Colorado provide with respect to stock of corporations, among other things, as follows:

"Subscriptions therefor shall be made payable to the corporation, and shall be payable in such installments and at such time or times as shall be determined by the directors or trustees; and an action may be maintained in the name of the corporation to recover any installment which shall remain due and unpaid for the period of twenty days after personal demand therefor, or, in case where personal demand is not made within thirty days after a written or printed demand has been deposited in the post-office, properly addressed to the post-office address of such delinquent stockholder."

It appears there was no demand or call made by the directors of the company on Kroegher for the unpaid balance of his subscription. But whatever may be the force of the above provision as between a solvent corporation and a delinquent stockholder, it has no application as between such a stockholder and the receiver of an insolvent corporation. The court which has jurisdiction of an insolvent corporation and has appointed a receiver therefor has full power to enforce the collection of all unpaid stock subscriptions without any previous call or demand by directors or trustees. In *Sanger v. Upton*, 91 U. S. 56, 23 L. Ed. 220, which involved the validity of an order in bankruptcy proceedings against a corporation for the payment to the assignee of amounts unpaid on its capital stock, Mr. Justice Swayne delivering the opinion of the court said:

"It was competent for the court to order payment of the stock, as the directors under the instruction of a majority of the stockholders might, before the decree in bankruptcy, have done. The former is as effectual as the latter would have been. It may, perhaps, be well doubted whether the stockholders would have voluntarily imposed such a burden upon themselves. The law does not permit the rights of creditors to be subjected to such a test. It would be contrary to the plainest principles of reason and justice to make payment by the debtor for such a purpose in anywise dependent upon his own choice. A court of equity has often made and enforced the requisite order in such cases. The Bankrupt Court possessed the same power in the case in hand. The order rests upon a solid foundation of reason and authority."

And in *Scovill v. Thayer*, 105 U. S. 143, 26 L. Ed. 968, Mr. Justice Woods delivering the opinion of the court said:

"It is well settled that when stock is subscribed to be paid upon call of the company, and the company refuses or neglects to make the call, a court of equity may itself make the call, if the interests of the creditors require it. The court will do what it is the duty of the company to do. * * * But under such circumstances, before there is any obligation upon the stockholders to pay without an assessment and call by the company, there must be some order of a court of competent jurisdiction, or, at the very least, some authorized demand upon him for payment."

The court below, in the suit of Rapp against the Calivada Colonization Company, having adjudged that company to be insolvent and appointed Hays, one of the appellants here, receiver, made March 31, 1900, on his petition for the collection of unpaid subscriptions, an order of reference to a special master to ascertain and report the facts and "if necessary state an account of assets and liabilities of said company." Pursuant to this order of reference the special master filed his report June 30, 1900, and the court having considered the same ordered July 3, 1900, that an assessment be made on the stock-

holders for the full balance of their unpaid subscriptions. The court had competent jurisdiction in the premises and its action, taken for the benefit of the creditors of the company, established an obligation on the part of Kroegher to pay to the receiver, who represented its creditors as well as its stockholders, \$1,500, the amount unpaid on his stock subscription.

But it is contended on the part of Kroegher that the reference to the master on the petition filed by the receiver, was "to adjudicate the amount due by the company to Kroegher", and that the allowance of the credit of \$1,500 on account of his stock subscription was outside the scope of the reference, and, further, that such credit was not properly the subject matter of a setoff against the indebtedness of the company to him. The learned judge below held that the allowance of the credit was by fair implication within the scope of the reference. The authority of the master under the interlocutory decree was, among other things, to ascertain "all the indebtedness of every nature and kind of the said Calivada Colonization Company to the said W. C. Kroegher, together with interest thereon to the date of the payment." Neither the petition nor the answer contained any statement that Kroegher's stock subscription had or had not been fully paid, nor any allusion to the matter. The pleadings disclosed nothing to notify Kroegher that it was sought to charge him with the whole or any portion of the unpaid amount of his subscription. It was an independent item of indebtedness, which did not become collectible and had not even been ascertained until after the reference to the master. Under these circumstances we are not prepared to hold that its allowance as a credit was within the scope of the reference. But it was ascertained and became collectible before final decree was made. Whether or not it was the subject matter of a setoff in its technical sense is, under the circumstances, an immaterial inquiry. It was due and payable to the receiver who, as before stated, represents both creditors and stockholders. It would be in the highest degree inequitable and a perversion of justice to permit Kroegher to obtain from the receiver out of the assets of the company the full amount of his claim against it, without paying to the receiver as part of its assets pledged for the security of its creditors the amount of his indebtedness for stock. To require the receiver to pay to Kroegher the whole of his claim and afterwards to bring an independent suit against him for the collection of the balance of his subscription would produce circuity of action without any necessity for such a course, and involve peril of loss to the creditors of the company. We think there was no error in deducting from the indebtedness of the company to Kroegher the balance of his stock subscription in the form of a credit.

The fourth and seventh assignments of error on Kroegher's appeal relate to the disallowance of sums claimed by him on account of certain alleged services and travelling expenses rendered and incurred by him while acting for the company. These items were rejected by the master on the facts as found by him, and his action was approved and confirmed by the court below. We perceive no reason for disturbing this finding.

The second and third assignments are based on the disallowance of two sums claimed by Kroegher, aggregating \$350, for expenditures made by him for the benefit of the ranch while in his charge after the sheriff's sale in August, 1899. Of the above amount Kroegher paid \$25 for trees, and the remaining \$325 for the working and management of the ranch. He has never been reimbursed in whole or in part for these two expenditures, nor received any money or profit from the ranch, and on the uncontradicted evidence he has a just claim for their amount. The master did not pass on the merits of the claim, but disposed of it by the following statement:

"Claimant testifies to a payment of \$325 while in possession of the ranch after the last sheriff's sale. This item is omitted from this account under the exception in the decree of February 10th, 1900; also the item of \$25.00 paid for trees at the same time."

Nor did the learned judge in his opinion pass upon the merits of the claim or allude to it; but in the final decree it is referred to as follows:

"Third. That there has not been included in this adjudication the claim of W. C. Kroegher for cash advanced at the ranch amounting to about Three hundred and twenty-five (\$325) Dollars, and for trees furnished to the ranch amounting to about Twenty-five (\$25) Dollars, which items are excluded from this decree."

We are unable to concur in the view of the master that the consideration and adjudication of the claim were precluded by what he terms an exception in the interlocutory decree. An examination of that decree shows that the "exception" was only intended to save the accounting therein ordered from the operation of the provision that "upon delivery of said assignment and the surrender of possession, all liability of the said Kroegher to said Company for an accounting as to his management of the ranch shall cease." We think his claim should have been allowed on any adjudication of "all the indebtedness of every nature and kind of the said Calivada Colonization Company to the said W. C. Kroegher", or of "any advances made by the said W. C. Kroegher of moneys used in and about the operation, care and management of the ranch and store of the company in Nevada." The second and third assignments on Kroegher's appeal must, therefore, be sustained.

The assignments of error on the receiver's appeal do not require much discussion. We shall briefly consider them in their inverse order. The fourth assignment alleges error in the allowance to Kroegher of "any interest upon the principal debt". The evidence does not show fraud or mala fides on his part. It is true that while acting for the company he insisted on collecting from it on account of his purchase of the two mortgages more than he paid for them. But under the circumstances disclosed in the case it is quite likely he believed that in so doing he was only asserting a right possessed by him. He was advised that he had such a right, and certain entries in the books of the company gave some color to his asserted claim. The fourth assignment cannot be sustained. The second and third assignments are based on the allowance of interest at the rate of eight per cent. per annum on the principal indebtedness of the company to Kroegher. But the evidence shows that it was fairly under-

stood and agreed between the company and Kroegher that he should receive that rate of interest on its indebtedness to him for his expenditures and services on its behalf in connection with its ranch in Nevada. The fact that such agreement was had in Pennsylvania where interest is limited to six per cent. did not affect its validity, unless it was made with the intention and as the means of evading the Pennsylvania statute; and of this there is no evidence. The company, a Colorado corporation, in good faith and with reference to the laws of Nevada, agreed to pay him eight per cent. on its indebtedness to him for advances, expenditures and services made and rendered or to be made and rendered, by him, not in Pennsylvania, but where such a rate was allowable. Such rate of interest is permissible in both Colorado and Nevada. We cannot assume, in the absence of evidence, that the "place of performance" was in Pennsylvania, and not in Colorado, the home of the company, or in Nevada, where the company's property was situated on account of which the advances, expenditures and services were made and rendered. Under these circumstances the second and third assignments must be overruled. The first assignment is that the "Court erred in dismissing the exceptions filed in behalf of the Receiver to the Master's report." This assignment is too general, and, further, we have failed to find anything to support it. It is, therefore, overruled.

Our conclusion on the whole case is that the appeal of the receiver must be dismissed; that the appeal of Kroegher must be sustained on the second and third assignments of error, and dismissed as to all other assignments; that the decree of the court below must be modified by increasing the amount awarded to Kroegher by the sum of \$350, together with interest thereon at the rate of eight per cent. per annum; that, subject to such modification, the decree should in all respects be affirmed; and that the costs on both appeals should be paid by the receiver. And it is so ordered.

WILSON et al. v. PARVIN et al.

(Circuit Court of Appeals, Sixth Circuit. January 6, 1906.)

No. 1,105.

1. BUILDING AND LOAN ASSOCIATIONS—POWER TO ISSUE PREFERRED STOCK.

A building and loan association, in the absence of charter or other legal inhibition in the law of the state of its origin, may lawfully give one class of shares preference over another, both with respect to dividends and principal.

2. SAME—INSOLVENCY.

Under the law of Tennessee building and loan associations have, in common with other corporations, the power to borrow money and to mortgage the corporate property to secure the same. By an amendment of the law in 1893 (Shannon's Code, § 2175) such associations were authorized to issue prepaid shares bearing a fixed dividend payable out of the profits. An association, authorized thereto by a by-law, issued such shares, the principal to be payable at a fixed time, or sooner, on notice given either by the holder or the association. Such shares provided that payment of both principal and dividends should be secured by a pledge in trust of notes and mortgages payable to the association, and in ac-

cordance with such provision a trust agreement was executed, and each certificate issued bore a certificate of the trustee that the required securities had been deposited. The holders of such shares were not entitled to vote, and the proceeds were placed in the fund to be loaned to borrowing shareholders. *Held*, that the issuance of such shares was within the powers of the association, being in effect but a form of borrowing, and that the preference given was lawful, as between the holders and other shareholders, and could be enforced after the insolvency of the association to the extent of the securities pledged; there being no outside creditors.

3. SAME—REGULARITY OF ISSUANCE—RATIFICATION.

Such shares were not invalidated by the fact that, when some of them were issued, there was no by-law authorizing them, where such action was subsequently ratified by the voting shareholders, and a by-law adopted authorizing their future issuance, and where no objection was made by any class of shareholders until after the insolvency of the association.

4. SAME—INTEREST ON PREFERRED STOCK.

Holders of paid-up stock of a building and loan association, although entitled by the contract to preference in payment of both principal and dividends, such dividends, however, to be payable only out of profits, are not entitled to interest on their shares after the association has become insolvent and ceased to make any profits.

Appeal from the Circuit Court of the United States for the Eastern District of Tennessee.

This is an appeal from a decree rendered by District Judge Clark settling the order in which the assets of an insolvent building loan association should be distributed among the members. The Cumberland Building Loan Association is a corporation organized in 1892 under the general law of Tennessee providing for the organization of building and loan associations. Being unable to carry on its business as contemplated and unable to meet its contracts with its stockholders, the appellees, who are citizens of states other than Tennessee, and unadvanced stockholders, filed a bill in the court below to have it wound up as an insolvent corporation. The general debts of the company, if any there were, have all been provided for, and the only questions which remain involve the rights and interests of different classes of certificate holders. The only question involved by this appeal concerns the status of a certain class of holders of certificates called "Fixed Dividend Income Stock." These certificates were in this form:

"Incorporated under the Laws of the State of Tennessee, United States of America.

"8 Per Cent. Per Annum Fixed Dividends.

"Income Stock.

"Payable in Gold.

\$500.00.

"Cumberland Building Loan Association, Chattanooga, Tennessee.

"Number 1.

Shares, 5.

"This certifies ———, of ———, is the owner of five shares, of the par value of one hundred dollars each, of the fully paid eight per cent. fixed dividend income stock of the Cumberland Building Loan Association of Chattanooga, Tennessee. The stock represented by this certificate is sold, and this certificate issued and accepted by the holder, upon the following express terms and conditions:

"(1) This stock is fully paid in at par and is nonassessable, the holder incurring no further liability thereon. This stock is redeemable ten years from its date at its full par value, if not sooner called or withdrawn, and is payable in gold coin of the United States of the present standard of weight and fineness.

"(2) This stock is entitled to share in the profits of the association to the extent of eight per cent. per annum, payable semiannually in cash, as per

the coupons hereto attached, upon surrender of such coupons as they severally mature. This participation in the profits is by way of preference, and is paid and accepted in lieu of all other interest in the profits of the association; the right of further participation in the profits being expressly waived.

"(3) This stock cannot be withdrawn for two years from date of issue, but after two years it is withdrawable at its full par value with accrued dividends to date of withdrawal: provided, that sixty days' notice of withdrawal shall be given to the association at its home office before payment can be required.

"(4) After five years from date of issue, the association shall have the right upon sixty days' notice to call in, redeem, or cancel this certificate, making payment therefor in cash at the par value of the stock with accrued dividends: provided, that if not so called stock shall remain in force and effect until withdrawn as herein before provided. Sixty days after such call shall have been made, the stock shall cease to participate in the profits of the association, whether this certificate has been presented for redemption and cancellation or not.

"(5) The holder of this stock shall be regarded as a depositor with the association, and, in consideration of the specific conditions upon which this stock is issued and the preferences it is accorded, any right to vote this stock or participate in stockholders' meetings is expressly waived.

"(6) Stock of this class shall not be issued at any time to an amount in excess of fifty per cent. of the live assets of this association. To secure the holder of this stock against loss of principal, mortgages and mortgage notes of the association in amount equal to double the amount of stock issued are deposited with the trustee under a trust agreement as certified hereon.

"(7) This certificate is not valid unless certified by the trustee and registered by the Central Trust Company, New York.

"(8) The stock represented by this certificate may be transferred upon the books of the association only by the holder in person, or by his attorney in fact, upon the surrender and cancellation of this certificate properly indorsed. A transfer fee of one dollar shall be charged.

"(9) The contract between this association and the holder is stated in this certificate, and agents have no authority to alter or amend such contract in any particular.

"In witness whereof the Cumberland Building Loan Association has caused this certificate to be signed by its president and secretary, with its corporate seal affixed, at Chattanooga, Tennessee, this _____ day of _____, 189-.

"_____, President,
"_____, Secretary."

Upon the back of each certificate are the following:

"Trustee's Certificate.

"This certificate of stock form one share is secured by the deposit with Wiehl, Probasco & Co. (Bank of Chattanooga) of first mortgage note receivable, and mortgages securing the same, of the Cumberland Building Loan Association, in accordance with a trust agreement dated November 1, 1893, and the holder hereof is entitled to the benefits of the trust created by said agreement.

Wiehl, Probasco & Co. (Bank of Chattanooga), Trustee,
"By H. S. Probasco."

"Register's Certificate.

"Countered and registered this, the 5th day of May, 1894.

"Central Trust Company of New York, Register,
"By _____, Secretary."

To each certificate there were attached 20 coupons, in form as follows. Each of said coupons provides as follows:

"The Cumberland Building Loan Association promises for value received to pay bearer, on the 5th day of _____, at the office of the association in Chattanooga, Tenn., or at the Chase National Bank in the city of New York, twenty dollars, semiannual dividend on fixed dividend income stock.

"C. R. Gaskill, Treasurer.

"Certificate No. _____."

To protect the holders of these certificates according to the contract set out, there was executed on November 1, 1893, a trust agreement, under which it was provided that there should be deposited with Wiehl, Probasco & Co., a firm of bankers at Chattanooga, Tenn., as trustees, an amount of the first mortgage notes and bills receivable, executed to the association by its advanced members, in double the amount of the shares of this special stock outstanding; and it was provided, among other things, "that no stock certificate shall be certified by the trustee at any time unless it holds as depository and in trust hereunder such notes, bonds, or bills receivable in said proportion as against such stock and the certificates representing the same." This agreement also provided for additional deposits from time to time of other notes, bills, etc., as those on deposit should diminish in value by the periodical payments on the stock which had been advanced upon. The purpose of this trust was declared to be:

"(1) The deposit of said securities is to secure the repayment to the holders of the fixed dividend income stock of the Cumberland Building Loan Association of the par value of said stock, which shall be payable, if demanded by the holder, in gold coin of the United States of the present standard of weight and fineness. But said stock shall only be payable or withdrawable in accordance with the provisions of the certificate issued therefor and certified by the trustee herein.

"(2) The deposit of said securities is also to secure the preference in the payment of dividends upon said stock out of the profits of the Cumberland Building Loan Association as hereinbefore recited and as specified in the certificate issued for said stock. It is not a guaranty of the payment of dividends if the association makes or has no profits from which to pay them. It is a guaranty of the principal of the investment and of priority in the division of profits in favor of the holder of the fixed dividend income stock.

"(3) The deposit of said securities is with full power to the trustee to sell and dispose of or enforce collection of the same after thirty days' written notice to said association, in ratio of two dollars of the net value of said securities as against one dollar of the par value of said stock, in the event that said association shall make default in the payment of the par withdrawal value of said stock, or any part thereof, at its maturity ten years from its date of issue, or at any earlier period when, under the terms of the certificate issued therefor, said stock shall be tendered for withdrawal at its par value and notice given of withdrawal according to the provisions of the stock certificate aforesaid. But no sale or enforcement of the collection of such securities shall be made by the trustee under this provision until default shall have continued for six months on the part of the association, and then such sale or enforcement of securities shall only be made to protect stock upon which the payment of withdrawal value shall be actually in default. This provision shall not be construed to permit the sale or enforcement of securities in order to pay off stock which has not been withdrawn or matured, and in the payment of which no default has been made. It is for the protection of such stock as the association may make default in paying as hereinbefore stated, when same has matured or been tendered for withdrawal in accordance with its terms, and with the terms of the charter, constitution, and by-laws of the Cumberland Building Loan Association. No right shall exist to proceed in like manner to enforce the payment of dividends which may be in default, unless it appears that there are profits from which such dividends are payable, and which are not being used to pay the holders of fixed dividend income stock dividends thereon, as having priority and preference over all other classes of stockholders; the purpose of this agreement being to guaranty the payment of the principal of fixed dividend income stock, but only to secure a priority and preference in the payment of dividends thereon."

The trust agreement contains many other details not necessary to set out in reference to the management of the assets so set apart. From time to time certificates were issued under this trust agreement; the first issuing some time early in 1894, and the last in March, 1898. There were assets in the hands of Wiehl, Probasco & Co. more than enough to fully pay these unpaid certificates when this proceeding was begun. Upon a petition filed in the principal case by the receiver these assets were, by order of the court

below, taken out of the possession of the trustee aforesaid and placed in the hands of the appellant receiver, who was ordered to collect same in and hold subject to the future order of the court. Judge Clark held that the holders of these dividend certificates were entitled to be paid in preference to the other classes of stockholders, with interest from date of last dividend paid to them. From this decree the receiver and certain unadvanced stockholders have appealed.

A. W. Gaines, for appellants.

Lewis M. Coleman and W. B. Swaney, for appellees.

Before LURTON, DAY, and SEVERENS, Circuit Judges.

LURTON, Circuit Judge, after making the foregoing statement of the case, delivered the opinion of the court.

The question is whether the interveners, holding the very peculiar certificates called "Final Dividend Income Stock," are entitled to preference in the distribution of the assets of an insolvent building loan association, or whether they must share ratably with those members of the association who are confessedly holders of ordinary shares of stock. If the certificates represent money merely loaned to the association, money borrowed for the purpose of carrying on the legitimate business of the incorporation by advancing those shareholders holding what is known in the parlance of such clubs as "installment stock," then it is too plain for argument that the holders of such certificates are creditors, and entitled to be paid in preference to any and every class of mere stockholders.

The power "to borrow money and issue notes or bonds upon the faith of the corporate property, and also to execute a mortgage or mortgages for repayment of money thus borrowed," is every explicitly granted to all corporations organized for individual profit under the general law of Tennessee authorizing the organization of such corporations. Acts Tenn. 1875, c. 142, § 5; Shannon's Code Tenn. § 2054. The provisions of section 2054 are included in the powers of every building and loan corporation organized under the general law of Tennessee. Acts 1875, c. 142, § 14; Association v. Cowley (Tenn. Ch. App.) 52 S. W. 313; Shannon's Code, § 2180. But the power to borrow for proper corporate purposes has been implied under charters and laws not explicitly granting it. Murray v. Scott, 9 App. Cas. 519, reversing *In re Guardian Permanent Ben. Bldg. Soc.*, 23 Ch. Div. 440. And so is the weight of modern cases. 4 Am. & Eng. Enc. Law, 1022, and cases cited.

The constitution of the Cumberland Association provided that the by-laws might provide "for the issuance of such bonds, certificates of deposit, or other securities of the association as the board of directors may from time to time deem it advisable to issue and sell to investors, and the stockholders may by resolution confer power upon the board of directors to pledge the mortgages, bills receivable, and other securities of the association to secure such bonds, certificates of deposit, or bills payable of the association." The fifteenth by-law was in these words:

"The board of directors are authorized and empowered from time to time to cause to be issued by the president and secretary such notes, bonds, certificates of deposit, and other evidences of debt as may be necessary for

money borrowed for the use of the association or deposited with it for investment. They shall prescribe the time for which said notes, bonds, certificates, or other evidences of debt shall run, the extent to which they or any of them shall share in the profits of the association, and may fix the terms and conditions of each issue of such security. The funds derived from such sources shall be, unless borrowed for a temporary specific purpose, placed in the loan fund of the association."

By resolution of the stockholders of April 5, 1893, the directors were given authority to deposit the securities of the association to secure any loan under by-law 15. There was no by-law explicitly authorizing shares of prepaid or preference stock on November 1, 1893, the date of the trust agreement with Wiehl, Probasco & Co. But at the regular annual meeting of the voting stockholders, July 10, 1894, the action of the directors in issuing such shares and in securing same by the deed of November 1, 1893, was unanimously confirmed and ratified; the action of the stockholders being put in the form of an amendment to the by-laws. July 13, 1897, the by-laws were formally amended, so as to more distinctly authorize such shares and for securing same by pledge or deposit of the mortgage notes of the association. The issue of such shares began in January, 1894, and continued until 1898; each certificate being certified to as secured under the agreement of November 1, 1893. The certificates outstanding at one time aggregated \$50,000, but when this bill was filed all had been paid off according to the contract except \$22,000.

It is not at all clear that these certificates do not in substance represent loans, and not membership in the corporation. Very similar certificates have been held to constitute the holders creditors, and as such entitled to priority, at least over members. *Cook v. Association*, 104 Ga. 814, 30 S. E. 911; *Building Co. v. Silverberg*, 108 Ga. 281, 33 S. E. 908; *Burt v. Rattle*, 31 Ohio St. 116; *Dickinson v. Trust Co.* (Sup.) 52 N. Y. Supp. 672; *Munhall v. Boedecker*, 44 Ill. App. 131. But it is not necessary to decide whether the holders of these special certificates are entitled to priority as creditors, because it is very clear that, if they are not creditors, it is because they are preferred stockholders,—preferred both as to dividends, if there were profits applicable to dividends, and principal, to the extent that the assets set apart for that purpose will satisfy their claims.

But the appellants, the receiver and certain unadvanced stockholders, say that the association had no power to issue preferred shares, or to secure same, as against the ordinary shareholders, and that the certificates are valid only as ordinary, unpreferred, prepaid shares, being entitled to no priority either as creditors or preference shareholders. Did the association exceed its powers in issuing preferred prepaid shares and in securing them by a pledge of its assets? The question is to be answered apart from any question as to the effect of such a preference upon general creditors. There are no general creditors. The question here is whether the preference accorded this class of stock is valid as against other members of the corporation who have assented to or acquiesced in its issue?

Much has been said about the issuance of preferred shares being "violative of the principle of equality and mutuality," which, it is said, is the distinctive thing characterizing such associations. That pre-

ferred shares do disturb the "equality" of interests which ordinarily prevails between shareholders may be conceded. That business corporations may generally, in the absence of charter or other legal inhibition in the law of the state of their origin, prefer one class of shares over another in respect to profits and principal, is now well settled. *Cook, Stocks & S.* § 268 et seq.; *Hamlin v. Railroad Co.*, 24 C. C. A. 271, 78 Fed. 664, 36 L. R. A. 826; *Warren v. King*, 108 U. S. 389, 2 Sup. Ct. 789, 27 L. Ed. 769; *Miller v. Ratterman*, 47 Ohio St. 141, 24 N. E. 496; *Murray v. Scott*, 9 App. Cas. 523, affirming *In re Guardian Permanent Ben. Bldg. Soc.*, 23 Ch. Div. 453, upon this point. There is no prohibition of such shares in the charter of this association or in the general law of Tennessee. If, then, the issuance of preferred shares with the consent of the members of a building and loan association is an act ultra vires, it must be because it is an act offensive to the object, plan, and general scheme of such corporations, and therefore not within the implied powers of this kind of an association. It is said, in some of the cases which deal with the scheme of such associations, that such shares are inconsistent with the mutuality of such organizations by introducing the mere investor as a factor, and that the loans made by such companies to installment members would be usurious, but for the supposed mutual contribution of all to the fund thus loaned and the equal participation of all, including the borrowing members, in the contributions arising from interest, premium, dues, and fines. It is also said that the scheme of such association only contemplates the payment of members in advance out of the fund resulting from the small periodical payments from all the shareholders alike, and that there is in fact no lending or borrowing, but that the notes taken and the mortgage given by an advanced member are only to secure the periodical payments due from him until his stock is matured and his note and mortgage thereby canceled. This was doubtless the original theory of the Tennessee incorporating act of 1875, for one provision of that act, now found as section 2132, Shannon's Code, was that "the monthly call for payment of said installments shall not exceed two dollars on each and every share." This provision would seem to preclude prepaid shares, and by inference preferred shares. But this general law was amended by chapter 12, § 1, Acts 1893, being now section 2175, Shannon's Code. This amendment authorizes in express terms the issuance of "installment stock, to be paid for in periodical sums, and prepaid and paid-up stock, upon which a gross sum shall be paid in advance in cash, as may be prescribed by the by-laws; and cash dividends may be paid on the stock authorized to be issued, out of the net earnings, as the by-laws may prescribe, provided such dividends shall not exceed the per cent. of profits earned."

In order to "advance members" there must be a fund out of which they may be advanced. The slow accumulations from subscribers paying only two dollars per share each month was doubtless found unsatisfactory to those it was intended to assist in the acquisition of homes by the aid of such companies. This amendment was accepted by this association April 5, 1893, and on November 1, 1893, the directors authorized the issuance of the shares in question and the

execution of the mortgage of that date. The first certificate, as heretofore stated, was issued June 4, 1894, and from time to time other certificates were issued, the last some time in 1898; the deposit of mortgage notes being increased from time to time, so that at all times there has been a pledge of assets to protect these special certificates according to the terms of the contract. The necessary operation of this amendment was to authorize two wholly distinct classes of stock, the installment shares and the fixed dividend shares. The first would naturally be sought by those expecting to borrow, while the other class would be inviting only to those seeking an investment. The object in permitting these investment shares was plainly to assist those members of such associations who needed loans or advance to aid in procuring homes by inducing contributions from a special class of members, who might be tempted by the promise of receiving as a dividend a larger return upon their money than otherwise admissible. So far, then, as these are prepaid shares, contracting for cash dividends payable out of the net earnings of the association and not otherwise sharing in the profits, they are clearly authorized by the amended charter.

But it is said that the amendment does not authorize any preference, except one out of the profits for the payment of the preferential dividend, and that the agreement to redeem or cancel these shares in preference to others out of assets set apart for that purpose is beyond the scope of the power. To admit that the charter as thus amended does not expressly authorize a preference in respect to the principal of such shares does not advance the argument. To issue preference shares is within the implied authority of every corporation, unless prohibited by some positive provision or repugnant to the general object and purposes of the organization. Now, if the organic law of this association has been so amended as to invite a class of shareholders solely for the purpose of enlarging the fund accessible to the installment or borrowing members, we are wholly unable to see how it can be said that associations having not only the express power to borrow money for corporate purposes, and to secure same by mortgage, but the power to issue prepaid shares bearing a fixed dividend payable out of the profits, may not prefer such shares both in principal and dividends. There is no public policy against it, and the preference is neither unjust nor immoral. It is, after all, but a form of borrowing; the lender receiving a limited dividend in place of interest and having no further interest in the association.

Building and loan associations are peculiar corporations. In none other is it admissible that the capital shall be withdrawn at the will of the stockholder. But in these it is expressly provided that any stockholder may withdraw, on giving 30 days' notice thereof, and receive "the amount paid in and such proportion of the profits as may have accumulated." The only limitation upon the privilege found in the charter is that but one-half of the funds in the treasury is subject to such demands without the consent of the directors. This withdrawal privilege, it has been held by some courts, is suspended upon insolvency, and all paid alike, whether notice has been given before insolvency or not. *Latimer v. Investment Co.* (C. C.) 81 Fed. 776; 4 Am. & Eng. Enc. Law, 1051; *Post v. Association*, 97 Tenn. 408,

37 S. W. 216, 34 L. R. A. 201. But these decisions rest upon the interpretation of the by-laws, constituting the contract in respect to withdrawals; it being held that the right exists as a contractual right only while the corporation is a going concern. The certificates in question limit this right of withdrawal, as the holder in effect waives the right and agrees not to exercise it for two years, unless the profits of the association shall fail to pay him a dividend for a period of six months. In view of the fact that the subscriber to such fixed dividend stock is in substance and effect a lender, his membership being a nominal thing, having no right to participate in the management and no interest in the profits beyond the amount he has contracted to receive, we see no inconsistency in an agreement preferring him in the assets set apart to secure to him his money on withdrawal or at the maturity of the transaction as fixed by the contract. There are no creditors to deal with. The transaction here involves only the validity of an agreement as between the shareholders, and we express no opinion in respect to the validity of the trust arrangement to protect these certificate holders as against general creditors.

We have not been referred to any decisions by the Tennessee courts which involve the power of associations organized under the laws of Tennessee to issue shares preferred as to dividends and principal. *Province v. Association*, 104 Tenn. 458, 58 S. W. 265, involved only the power of such associations to contract to mature shares within a definite time. The holding there was that any contract by which "it should undertake to give one of its members a greater share of profits than another, or to relieve him preferentially from the full discharge of his obligation to the association by payment of a part, would be in violation of this principle of mutuality." The certificates here involved present no such contract. In *Post v. Association*, 97 Tenn. 408, 37 S. W. 216, 34 L. R. A. 201, it was held that dues paid in advance, upon ordinary installment shares, under an agreement that interest should be allowed upon such advance, did not constitute the stockholder, in a case of insolvency, a creditor to the extent of such advance. After referring to the provision forbidding the requirement of a greater monthly payment than two dollars on each share, Judge Wilkes, in speaking of the arrangement by which payments of dues might be made in advance and interest allowed thereon, said:

"It was, in some respects, the same thing as if the association, in order to accommodate its borrowers, had gone to some bank or outside person and borrowed money to put into the association. Such a proceeding is not warranted by the charter, or the proper scope and scheme, of a building and loan association. They should not be borrowers of money, but only lenders, for the proper purposes of their creation. To allow the amounts advanced to be paid back would be to sanction such proceedings as legitimate loans, to convert capital into loans, and to create preferred stock, in order to work out supposed equities. We think the proper holding upon this matter is to treat the advances as payments upon stock, and not as loans to the company; and this is, in effect, carrying out the intention of the parties, which was to pay up their stock in advance, and, by anticipation of its maturity, receiving a discount by so doing."

The conclusion that such payments should be regarded as advance payments on stock, "and not as loans to the company," was the ground upon which the decision was put, and a proper interpretation

of the transaction. The observations of the learned judge, as to the want of power in such companies to borrow or to issue prepaid stock were dictum, and wholly overlook the express power to borrow conferred by section 5 of the act of 1875, as well as the power under the act of 1893 to issue prepaid stock bearing a fixed dividend out of profits. It is more than probable that this transaction occurred before the amendment of 1893, or that the association had not accepted that amendment; otherwise, these provisions would have been considered. At most, the case is no authority for the contention that an agreement giving a preference to authorized and valid prepaid stock over the ordinary shares is invalid as between the members of the company.

The power to borrow for the purpose of lending to members was recognized as one which existed within limits by the Tennessee court of chancery appeals in *Association v. Cowley*, 52 S. W. 313. In re *Guardian Permanent Ben. Bldg. Soc.*, 23 Ch. Div. 440, is a well-reasoned case, and is directly in point. In that case a by-law was held valid which gave directors power to issue paid-up shares with the right to withdraw in preference to the ordinary unadvanced members. The case on this point was affirmed in *Murray v. Scott*, 9 App. Cas. 519. In *Murray v. Scott*, just cited, the power to borrow money to enlarge the lending fund, and to secure such loans by a preference over all shareholders and members, was recognized as a valid power by implication, and held to be a legitimate method of carrying out the ends and objects of the association; no such power having been either granted or prohibited.

In conclusion, we hold that the power exercised in issuing prepaid shares, preferred as to dividend and principal, is a valid exercise of the powers of the corporation inter se, and not so inconsistent with the purposes and objects of such an association as to be regarded at this late day as a void and illegal thing.

A question has been made against the validity of these shares as preferred shares, because, when some of the shares were issued, there was no by-law authorizing such action by the board of directors. This was cured by the subsequent confirmation of what had been done, both in respect to shares already issued and in the execution of the trust agreement of November 1, 1893, to secure such preferred shares as should from time to time be issued. This curative action was given the aspect of an amendment to the by-law, and operated both retrospectively and prospectively. Aside from this affirmative action of the stockholders, there is abundant evidence in the reports of the officers, the action of subsequent stockholders' meetings in sanctioning the payment of dividends on such shares, and in the literature of the association, that the action of the directors in this matter was notorious. There was no objection or protest until the insolvency of the association was evident.

Until January, 1898, the only shares which had the right to vote were shares called "common stock." At that time the right of voting was, at a meeting in which every class of stock participated, extended to stockholders of every class, including these fixed dividend stockholders. We had occasion lately to determine the effect of this extension of the right of management upon the contracts with the "common

stock" which had reserved to itself the exclusive power of voting. *Synnott v. Association* (C. C. A.) 117 Fed. 379. It is now urged that the stockholders who prior to 1898 had no right to vote should not be precluded by any action taken by the small class of common stockholders who could. This objection comes too late. If the objectors were members when the common stock authorized or ratified the issuance of such shares, they were bound by the action of the common stock, which under the by-laws of the society could alone vote. The nonvoting stock was all subscribed with that provision in force, and, if it was void, it was incumbent upon disfranchised stockholders to act promptly in giving effect to their dissent to any exercise of a power which could be validly exercised if authorized by the members. The case is even less plausible in respect to those who became members only after this kind of stock has been resolved upon and the trust deed of November 1, 1893, executed. The association's assets have been increased, to the extent of the par of every share of this preferred stock, in reliance upon the validity of the contract evidenced by the shares themselves and the trust deed under which they were issued. The corporation had the power to make the contract it did make. Irregularities in the exercise of the power may be waived by acquiescence or by a want of diligence in objecting. This record is full of evidence of assent, confirmation, and acquiescence upon the part of the stockholders of every class to the sale of these shares.

The decree gave to these certificates interest after payment of last dividend. This is error. The contract did not require the payment of interest. The dividend was not payable at all events but only out of profits. This is the plain meaning of the contract. *Lockhart v. Van Alstyne*, 31 Mich. 76, 18 Am. Rep. 156; *Warren v. King*, 108 U. S. 389, 2 Sup. Ct. 789, 27 L. Ed. 769; *Cook, Corp.* § 271; *Taft v. Railroad Co.*, 8 R. I. 310, 5 Am. Rep. 575. When the association became insolvent, it ceased to have any profits out of which to pay dividends. The decree will be modified, so as to give a preference to the principal, without interest. If the assets were sufficient to repay the entire capital, and leave a surplus, a different question would arise; for such surplus would be profit.

The decree is in all other respects affirmed.

CITY OF CHICAGO v. LE MOYNE.*

(Circuit Court of Appeals, Seventh Circuit. October 7, 1902.)

No. 734.

1. MUNICIPAL CORPORATIONS — STRUCTURES BUILT IN EXERCISE OF POLICE POWER—INJURY TO PRIVATE PROPERTY.

Under the provision of the Illinois constitution that "private property shall not be taken or damaged for the public use without just compensation," a city is not relieved from liability for damages caused to property by the construction of a viaduct in a street because it was built by the city in the exercise of its police power.

* Rehearing denied January 6, 1903.

2. SAME—LIABILITY FOR DAMAGES.

A city which caused the construction of a viaduct in a street cannot escape liability for damages caused to abutting property on the ground that the order under which it was built was void.

3. EVIDENCE—ADMISSIBILITY OF PLATS.

It is no objection to the admissibility in evidence of a plat made by a witness from a survey made by him, showing the location and surroundings of property for injury to which the action is brought, that it is not the best evidence, and that the official plat should be produced.

4. DAMAGES—INJURY TO PROPERTY BY OBSTRUCTION OF STREET.

In an action to recover damages for injury to property owned by plaintiff by reason of the construction of an embankment for approach to a viaduct upon a street on which some of the lots fronted, while others were separated from them by an alley and fronted on another street, it is competent to show that the value of the latter was affected by the embankment by preventing access to them from the street on which it was built, through the lots fronting thereon, where it was previously shown that all the lots were leased and used together as one tract, having a frontage on both streets.

5. SAME.

In an action to recover for an injury to property by the construction of a viaduct on the street upon which it fronted, benefits to the plaintiff in common with the public generally, resulting from the building of a street railway line on the street in consequence of the viaduct, cannot be shown to offset the actual damages caused by the viaduct, by preventing access to the property from the street.

6. SAME—EVIDENCE—DISCRETION OF COURT.

In such action a witness for defendant testified, without objection, that in his opinion the property could be so improved by the erection of buildings thereon to conform to the changed grade of the street that its value would not be lessened by the construction of the viaduct. *Held*, that the exclusion of a sketch made by the witness and offered in evidence to show the kind of building he would construct was within the discretion of the court, and, even if erroneous, was not prejudicial.

7. APPEAL—REVIEW—ERRORS NOT AFFECTING MERITS.

When it is manifest that a plaintiff is entitled to recover damages, and the amount awarded him is as small as it can reasonably be expected would be given by another jury, the judgment will not be reversed because of technical errors in procedure on the trial.

8. INSTRUCTIONS—TIME FOR PRESENTING REQUESTS.

The practice of presenting instructions to the court after the charge to the jury has been given cannot be sanctioned, and assignments of error based on the refusal to give such instructions will not be considered by the appellate court.

9. MUNICIPAL CORPORATIONS—ACTION FOR INJURY TO PROPERTY BY CONSTRUCTION OF VIADUCT—INSTRUCTIONS.

Instructions with respect to the measure of damages recoverable for an injury to property by reason of the construction of a viaduct on the street in front of it examined, and *held* free from material error.

In Error to the Circuit Court of the United States for the Northern District of Illinois.

The defendant in error brought action against the city of Chicago for damage to his property occasioned by the construction of a viaduct in Halsted street, immediately adjacent to a portion of his premises. The block which contains the premises in question is bounded on the north by Thirty-Ninth street, on the east by Emerald avenue, on the south by Fortieth street, and on the west by South Halsted street. There is an alley running north and south through the center of the block. The block comprises 43 lots, numbered consecutively from 1 to 43, commencing at the corner of Thirty-Ninth street and Emerald avenue, except that lot 43 is situated at the southwest corner

of the block, and is bounded on the north by a 16-foot alley running east and west from Halsted street to the north and south alley. The lot is 44 feet in width on the north and south alley, and runs to a point on Halsted street. Le Moynes was the owner of lots 1 to 8, both inclusive, and of lots 14 to 22, both inclusive, all fronting on Emerald avenue; of lots 38 and 39, being the fourth and fifth lots south from the southeast corner of Halsted street and Thirty-Ninth street; and of lot 43, above described. Fortieth street had for years been occupied with 17 railway tracks of the Stockyards & Transit Company, which owned or occupied all the property on the west side of Halsted street from Thirty-Ninth street on the north to Forty-Seventh street on the south. Upon Halsted street was constructed and operated a street car line as far south as Fortieth street, and there was also a street car line on South Halsted street extending from the south side of Fortieth street, the street railway not crossing Fortieth street on account of the numerous railway tracks thereon, so that passengers traveling north and south over Fortieth street were obliged to do so on foot. The city caused to be constructed the viaduct in question for the purpose of uniting the two street railways, and to give them an overhead crossing, to avoid the dangerous grade crossing on Fortieth street. The viaduct required an elevation of the grade of Halsted street. This began a little north of Thirty-Ninth street, rising to the south. In front of lots 38 and 39 the elevation was 5.69 feet, and at lot 43, 18.29 feet, above the established grade. The viaduct was constructed under contract with the city, and under an order of the city passed January 6th, which was as follows:

"Whereas, by order of the city council, passed October 14, 1895, the department of public works was directed to notify the Chicago City Railway Company to run its cars on Halsted street, across the railroad tracks at Fortieth street, in order not to compel passengers to take transfers at that point and walk a block across the tracks; and by resolution of the city council of December 9, 1895, a committee was appointed to confer with the Chicago City Railway Company, in regard to the inadequacy of service in that portion of the city; and by order of the city council, passed December 23, 1895, the commissioner of public works was directed to compel the Chicago City Railway Company to run their cars on Halsted street, from O'Neil street to 69th street, without change of cars; and whereas, by order of the city council, passed September 22, 1890, the mayor and commissioner of public works were directed to confer with the Union Stock Yard and Transit Company to the end that some mutual agreement might be made for the construction of a viaduct over the stock yards tracks across Halsted street, between 39th and 40th streets; and in the report regarding the elevation of the tracks of the Union Stock Yard and Transit Company, submitted to the mayor by the consulting engineer of the city, under date of May 29, 1895, it is recommended that the elevation of such tracks commence east of Halsted street, and that a viaduct be constructed over the seventeen (17) tracks of that company, which pass out of the stock yards and occupy a length of some 350 feet in Halsted street, in order to obviate the great danger and delay at this grade crossing, which will be aggravated through the introduction of the electric cars of the Chicago City Railway Company on Halsted street, across these numerous railroad tracks:

"Ordered, that the mayor and commissioner of public works be, and they are hereby, directed to cause plans to be forthwith prepared for a viaduct, with suitable approaches, on Halsted street, over the tracks of the Union Stock Yard and Transit Company south of 39th street, and to let the necessary contracts for the construction of the same, upon obtaining from the Union Stock Yard and Transit Company and the Chicago City Railway Company, or either or both of said companies, an agreement to provide all moneys required to meet such contracts."

At that time lots 1 to 8, both inclusive, and lots 38 and 39, were occupied by one Donahue for the purpose of a coal yard, with its business frontage on Halsted street, under lease dated 1893, and expiring in 1906; and lots 14 to 22, both inclusive, and lot 43, were occupied by one Flannagan in a slaughtering and packing business, with an entrance on Halsted street and none upon Emerald avenue, under lease dated 1892, and expiring in 1902. The north

and south alley was either not known as such to the public, or was used in connection with and as part of the property. It had not in fact been open to the general use of the public, but had been built upon by the tenants of the property in question and of the other lots in the block.

The trial resulted in a verdict for the plaintiff below, and upon writ of error the city of Chicago brings the cause here for review. There are 73 assignments of errors in the record, which may be thus classified: 3 with regard to the refusal of the court to direct a verdict for the city; 35 with regard to the admission or exclusion of evidence; 23 with regard to the refusal of instructions requested by the city; 6 with regard to the charge of the court; and 4 with regard to the refusal to award a new trial for excessive damages, that the verdict was not sustained by the evidence, and for error in entering judgment upon the verdict. So far as deemed essential, these assignments are stated in the opinion.

Thomas J. Sutherland, for plaintiff in error.

Wey Frank Hamlin, for defendant in error.

Before JENKINS, GROSSCUP, and BAKER, Circuit Judges.

JENKINS, Circuit Judge (after stating the facts). The contention that the construction of the viaduct was in the legitimate exercise of the police power of the city, and that any damage to property thereby occasioned is *damnum absque injuria*, notwithstanding the constitutional provision that "private property shall not be taken or damaged for public use without just compensation," cannot be sustained. The question is set at rest by the recent decision of the supreme court of Illinois, in *City of Chicago v. Jackson* (as yet unreported officially) 63 N. E. 1013, holding, with Judge Dillon, that "a right conferred or protected by the constitution cannot be overthrown or impaired by any authority derived from the police power." *Dill. Mun. Corp.* (3d Ed.) § 142. So, also, the contention that the order of the city council of January 6, 1896, is void, and furnished no authority for the construction of the viaduct, is without support in law. The city, having caused the construction, must respond for the damages occasioned. It cannot shield itself under cloak of a void order. *City of Chicago v. Spoor*, 190 Ill. 340, 60 N. E. 540.

This brings us to the consideration of the many objections to evidence upon the trial, being 35 in number. It is to be remarked by way of preface that the bill of exceptions as presented is not conformable to the rule of this court. Rule 10, par. 2, 32 C. C. A. lxxxvii, 91 Fed. v, provides that a bill of exceptions "shall contain of the evidence only such a statement as is necessary for the presentation and decision of questions saved for review, and unless there be saved a question which requires the consideration of all the evidence, a bill of exceptions containing all the evidence shall not be allowed." The document submitted to our consideration is a stenographic report of all the proceedings of a trial continuing through five days. It embodies not only all the evidence, but all the arguments of counsel to the court, the remarks of the court, and colloquies between counsel; so that an unnecessary burden is imposed upon the court to search this voluminous record for the "two grains of wheat hid in two bushels of chaff." In the preparation of the bill the lawyer abdicated his function in favor of the stenographer. Such practice may be a saving of labor to counsel, but it is neither lawyer-

like nor just to the court or to client. This bill should never have been signed by the trial judge, and we would not be subject to just criticism if we declined to consider the errors assigned. We have concluded, however, to remark upon such of them as we think deserving of mention.

(1) The plaintiff below introduced a witness, who produced a plat made by him, which he stated was a correct plat of the property, showing its surroundings. The plat was made from an original survey by the witness. The lots placed upon the plat, and the figures of the dimensions of the lots, were obtained from the original plat on record in the recorder's office. The objection stated to the allowance of this plat in evidence is that it was not the best evidence, and that the original plat should have been produced. The objection is without merit. The object was to show to the jury the location of the property by the surveyor who had measured it. It would have been competent for him while upon the stand to have made a plat of the property as he found it for the inspection and information of the jury. Indeed, a similar plat of the property, with the lots and alleys projected upon it, had previously been offered in evidence and received without objection.

(2) In the cross-examination of the witness Woodruff he was called to testify to the character of the property and the use to which it was put and to the damage sustained. He was asked if access to South Halsted street in any way affected the value of the Emerald avenue lots. He had testified that Emerald avenue lots 1 to 8 had access to Halsted street through lots 38 and 39, and that those properties were used for a common purpose as one tract of land. He also testified that lots 14 to 22 had access to Halsted street through the alley north of lot 43, which property, with lot 43, was used for a common purpose. The objection to the question was that the owner was not interested in the traffic or ingress or egress on Halsted street. The objection is not well taken. The two properties, being thus used in common, had two frontages, one upon Emerald avenue and one upon Halsted street, and, if such access to the Emerald avenue lots gave value to the property, it was clearly competent to show it. The fact of the existence of the north and south alley intervening between the lots fronting on Emerald avenue and the lots fronting on Halsted street is not of moment, if the property be used for a common purpose. The existence of such alley aided rather than impeded such access. Access to the principal street could be had through the Halsted street lots or through the east and west alley.

It is also objected that the plaintiff in error was not permitted to prove upon the cross-examination of this witness that the market value of the property in question was not depreciated from other causes than the construction of the viaduct. We do not understand the court so to have ruled. The witness was being interrogated upon cross-examination whether the factories, breweries, and packing houses in the vicinity were not fronted upon Emerald avenue and not upon Halsted street, to which he gave an affirmative answer, and that they were built before the construction of the viaduct.

He added of his own motion that he did not know whether any other influences had worked upon the packing house business except the viaduct; that he did not know of any causes that had affected the business. The question was then propounded to him, "Or the value of that property?" to which there was objection. The counsel for the plaintiff below disclaimed damage for any reduction of the business carried on upon the property, and no evidence had been offered to show such decrease. The testimony of the witness was simply to the question of accessibility to the property, and the offer by the defendant at that time was to show the depreciation to business there occasioned by competition of the stock yards, and that the property of the plaintiff for packing house purposes had been injured from that cause. The question in the case was whether the construction of the viaduct had impaired, and to what extent, access to the property in question. The damages sought were for the impairment of that access, to whatever use the property might reasonably be put. The question was not proper by way of cross-examination, and it was irrelevant whether for packing house purposes the property was desirable by reason of the competition of great corporations. The defendant below was given full opportunity to prove the actual market value of the property before and after the construction of the viaduct, and has no right to complain of this ruling.

(3) It is objected that the trial court permitted testimony with respect to the traffic and business in connection with this property previous to the building of the viaduct. This contention is not sustained. The testimony went simply to the location and use of the property, and that the principal access thereto was from Halsted street. There was no claim by the plaintiff below for damage by reason of loss of business or diversion of traffic, nor any evidence offered in support of such claim. Much of the testimony which might seem to show diversion of traffic was brought out on cross-examination by the party now complaining of it; and the court was careful in its charge to inform the jury that "the diversion of trade from that particular locality by reason of better facilities being provided by the city for the public to reach other localities cannot be considered as an element of damage." And this instruction we understand to be in substantial accord with the doctrine declared in *Hohmann v. City of Chicago*, 140 Ill. 226, 29 N. E. 671.

(4) The defendant below propounded to a witness the question whether any advantage had resulted to the property in question by reason of the trolley system inaugurated on Halsted street subsequent to the building of the viaduct, through the increased facilities of access, and the question was excluded upon the ground that the benefit, if any, arising from the construction of the trolley system, was common to the neighborhood and could not be charged as a specific benefit to the land. This ruling, in our judgment; was clearly right. The supposed benefit sought to be proven was a general benefit to the community at large, within the doctrine of *Railway Co. v. Stickney*, 150 Ill. 362, 37 N. E. 1098, 26 L. R. A. 773, and *Palmer Co. v. Ferrill*, 17 Pick. 58. The supposed benefit of the trolley system did not arise directly and immediately from the building

of the viaduct; but, as is suggested in *Palmer Co. v. Ferrill*, from the application of capital, enterprise, and industry attracted thither by the establishment of the viaduct. The same consequences would ensue from the establishment of a trolley system without a viaduct. The fact that the viaduct induced the construction of the trolley system, because a railway crossing was thereby rendered safe which otherwise was dangerous, cannot convert the supposed general benefits to the community by reason of the establishment of the trolley system upon the street into a special benefit to the property in question, nor can they be offset against the actual damages accruing to the property by reason of nonaccess to the street caused by the viaduct. One may not be thus "improved out of his estate."

(5) A witness for the city undertook to show, and was permitted to testify, that the property in the changed condition of the street could be utilized by the construction thereon of flats and stores, adjusting the buildings to the changed condition of the street, and that thereby the value of the property would not have been injured. The witness stated that he had made a sketch, which he then produced, to show the appearance of the building which he would erect. It was a rough pencil sketch, intended merely for illustration. The sketch was offered in evidence and ruled out. It may have been well to have permitted the sketch to have gone in evidence, assuming that the testimony which was allowed without objection was admissible (*Railroad Co. v. Blake*, 116 Ill. 163, 4 N. E. 488; *Springer v. City of Chicago*, 135 Ill. 552, 26 N. E. 514, 12 L. R. A. 609), although the court in the *Blake Case* observed: "The practice, however, of introducing such evidence should not be encouraged, as there is generally more or less danger of its being misunderstood by the jury." The jury was possessed of the testimony of the witness touching the construction of the viaduct. The allowance of the exhibition of the plat to the jury was, we think, discretionary; but, at most, the ruling, if an error, was a harmless error.

We have thus considered such of the objections to testimony as we think it proper to mention. Undoubtedly the property was damaged by the construction of this viaduct. As the supreme court of Illinois observes in *City of Chicago v. Jackson*, *supra*: "No amount of expert evidence would be likely to ever convince any jury that this did not effect a damage to the property." In the case at bar the witnesses for the plaintiff below variously testified to the damage, the lowest estimate being \$7,750, and the highest \$12,980. The verdict was for but \$2,500. It is not improbable that in a trial lasting through five days there was technical error in the procedure, but none, it may be said, whereby the real merits of the case were affected. However much the plaintiff below may have right to complain with respect to the amount of the verdict, it appears to us that the defendant below could have slight cause for complaint. And we quite agree with the remark of the supreme court of Illinois in the *Jackson Case*, that "where substantial justice has thus been accomplished through the trial, and where it seems obvious that no decision more favorable to the appellant would result from another

trial, it is not necessary, nor is it proper, that the judgment should be reversed because of the errors in procedure above indicated."

Coming, now, to the instructions requested to be given in charge to the jury, and to the charge itself and exceptions thereto: There were 23 instructions requested. These were presented to the court, as the record shows, after the charge to the jury had been delivered, and after the defendant below had presented its exceptions to the charge. Such practice cannot be sustained. Instructions should be presented to the court before the charge to the jury. This is not only due to the court, but is owing also to the rights of the parties-litigant, and is in the public interest. The office of such request is to call the attention of the court to propositions of law supposed to affect the cause, that deliberation may be had thereon, and, if they be approved, incorporated in the charge of the court. It is unfair after the charge is delivered to press upon the court a whirlwind of requests to charge, possibly artfully contrived to entrap the court, and to require decision upon them without time for reflection. We have examined these instructions, and do not see that they raise any question material to the case that is not presented by the charge itself and by the exceptions thereto. We decline to discuss the question, because we are unwilling to sanction the practice here adopted and which we condemn. The charge itself is composed of 17 paragraphs upon different propositions with respect to the law and the evidence. It is thoroughly impartial upon the question of fact, and we need only consider it with respect to the law on the subject of damage, as the liability of the city for the damage occasioned, if any, has since the trial been determined, as we have before remarked, by the supreme court of Illinois.

The court carefully instructed the jury that the plaintiff below could not "in any manner or degree recover damages to the business of the lessees, or to the possession or occupation of the premises, during the term of the leases, but only the damages, if any, which had been occasioned to his reversionary interest in the property"; and the jury were cautioned to observe this distinction in weighing and considering the evidence of values and of damages which had been presented to them. We cannot comprehend the force of the objection to this part of the charge. With extreme care the rights of the defendant were protected in this respect, and the large difference between the amount of the verdict and the amount of the estimates of the witnesses for the plaintiff below makes clear that the caution of the court was not disregarded.

The court also charged that in estimating the damages, if any, accruing to the property in consequence of the construction of the viaduct, the diversion of trade from the particular locality by reason of better facilities being provided for the public to reach other localities, was not an element of damage, and should not be considered by the jury; and that it is only the special damage to particular property, as distinguished from damage to the public in general, by reason of the erection of this viaduct, which could be made the basis of an action; and this instruction seems to us to be correct.

The court also instructed the jury that the two alleys were public

alleys, and that the plaintiff had no right to the same different from the right of the public generally, and that the fact of their occupancy by the lessees to the exclusion of the public could add no value to the property. The jury were also charged, with respect to triangular lot 43, that if the plaintiff had the right of access to this lot from Halsted street by reason of the alley north of it, and that such access had been cut off by reason of the construction of the viaduct, and that thereby the lot had depreciated in its market value, such depreciation could be recovered. We see no objection to this charge or to the extension of it by the court to the Emerald avenue lots. There was no question in the trial that these alleys were public alleys. In the same breath counsel for the defendant below insists here that they were public alleys for the purpose of defeating the claim of the plaintiff as to the Emerald avenue lots, and that they were not public alleys for the purpose of defeating the claim of the plaintiff to lot 43. Whether the alleys were public or private, it is clear that access to these lots was actually had through them, and, if that access was cut off or impaired by the construction of the viaduct, the city would be responsible for the damage resulting.

The court also instructed the jury that no consideration should be given to any evidence of the benefit to the property by reason of the construction and operation of any street railway in that vicinity, but the benefits to be considered were such as are solely and strictly due to the construction of the viaduct, and upon that accruing especially to the plaintiff's reversionary interest in the property different from the benefits which may have accrued to the public generally "or to all the other property in that particular neighborhood." Possibly this latter expression may not be in exact accord with the ruling in *Railway Co. v. Stickney*, 150 Ill. 362, 37 N. E. 1098, 26 L. R. A. 773; and probably, if the court's attention had at the time been called to the expression, the instruction would have been modified. The exception to the charge, however,—which was manifestly prepared subsequently to the verdict, although incorporated in the bill of exceptions as made at the time,—is to the entire clause, and not to the particular part now complained of, and the rule is elementary that, if the clause of the charge excepted to embodies both correct and erroneous instructions and the exception be general, it cannot be sustained. The court here properly charged that the damage to this property could not be reduced by any supposed benefit growing out of the construction and operation of a street railway upon it. The city could not diminish the amount of the wrong it wrought by the benefit that some other corporation might give to the property. We are therefore not required to consider whether this particular clause in the charge is or is not erroneous.

It may be said that, with the exception of the alleged benefit from the construction of the trolley line, no element of benefit was kept from the jury. The sole claim for damage was the cutting off of access to the property. The benefit claimed, aside from that mentioned, was the doing away of a dangerous grade crossing, and evidence in that respect was admitted without question.

We have carefully scrutinized this charge and as well the instruc-

tions requested, to ascertain if any substantial right had been denied the city of Chicago, and if any error had intervened to its substantial detriment, and we can find none. There was a prolonged trial, resulting in a conservative verdict, which we are not disposed to disturb, and which the public interest requires we should not disturb for any error not affecting the substantial merits of the cause. The judgment is affirmed.

SUPREME LODGE KNIGHTS OF PYTHIAS v. WELLENOSS.

(Circuit Court of Appeals, Sixth Circuit. January 6, 1903.)

No. 1,107.

1. FRATERNAL INSURANCE—RIGHT OF FORFEITURE FOR VIOLATION OF LAWS OF ORDER—WAIVER.

Conceding the right of a fraternal order, which has also an insurance department which issues benefit certificates on the lives of its members, to regulate its internal affairs according to its own laws, and to expel or suspend members for their violation, yet, where such action terminates or suspends the rights of the member with respect to his insurance, the society is bound by the rules which govern other insurance contracts, and must act with reasonable promptness. The acceptance of premiums or assessments from the member after a right of forfeiture is known is a waiver of such right.

2. SAME—WAIVER OF FORFEITURE.

A prominent member of the order of Knights of Pythias, who also held a benefit certificate in the endowment rank payable to his wife, participated in certain action taken by a number of lodges in 1893 which was deemed rebellious and a violation of his obligation to the order. Attention was called to the matter in a report of the supreme chancellor to the supreme lodge in 1894, and the expulsion of such member from the grand lodge was recommended. In 1896 suspension from the order was recommended; but no effective proceeding to that end was taken until 1898, when charges were filed and a trial in 1899 resulted in the member's suspension for two years. Up to the time of such suspension he continued to pay the assessments on his certificates, which were received, and he made tender of all assessments thereafter until his death. At the time of his suspension he was sick with a mortal disease, and died soon after, never having been in a condition to obtain other insurance. *Held* that, conceding the right at that time to suspend him from the social and fraternal benefits of the order, such action, taken so many years after the cause of suspension was known, during which time his assessments had been accepted, could not deprive his beneficiary of the right to the insurance.

In Error to the Circuit Court of the United States for the Western District of Kentucky.

This action was brought to recover upon a certain certificate of insurance held by Henry Wellenvoss, husband of the plaintiff, Elizabeth Wellenvoss, issued by the Supreme Lodge Knights of Pythias. The circuit court directed a verdict for the plaintiff. The society is of a benevolent and fraternal character, and has a department of life insurance known as the "Endowment Rank." The association was incorporated under an act of congress in 1870. Amendatory laws were subsequently passed. After the expiration of the former charter the society was incorporated under its present title by the act of congress of June 29, 1894 (28 Stat. 96), and the amenda-

¶ 1. See Insurance, vol. 28, Cent. Dig. § 1909.

tory act of June 7, 1900 (31 Stat. 708). The "Endowment Rank" was organized in 1877. It was the purpose of this branch of the order to afford life insurance to members of the society. In 1877 Henry Wellenvoss, the husband of the plaintiff, a member of one of the lodges of the Knights of Pythias, took a certificate of insurance in favor of his wife. A like certificate was issued to him for the sum of \$1,000 on October 18, 1879. On April 27, 1885, he surrendered the two certificates mentioned and took out a new one for \$3,000, which is the certificate in suit. This certificate contained the following language: "And in consideration of the representations and declarations made in his application, bearing date of November 28, 1877, and his absolute surrender of the certificates heretofore held by him in first and second classes for cancellation, as requested in his application for transfer to the fourth class, bearing date of April 27, 1885, all of which is made a part of this contract and the payment of the prescribed admission fee, and in consideration of the payment hereafter to said Endowment Rank of all monthly payments as required, and the full compliance with all the laws governing this rank, now in force or that may hereafter be enacted, and shall be in good standing under said laws, the sum of three thousand dollars will be paid," etc. And the further provision, also: "And it is understood and agreed that any violation of the within mentioned conditions, or the requirements of the laws in force governing this rank, shall render this certificate and all claims null and void, and that the Supreme Lodge shall not be liable for the above sum or any part thereof."

The ritual of the society was printed in English. The second and third rituals were printed in 1872 and 1882, and were both in English and German. In 1892 the Supreme Lodge determined to print the ritual in English only. Henry Wellenvoss was a member of one of the lodges using the German ritual. He, with others, protested vigorously against this change, and a meeting of the representatives of the dissatisfied lodges was held at Indianapolis in June, 1893. At this meeting Wellenvoss was an active participant and was made chairman of its executive committee. Among others, the convention passed the following resolution: "Resolved, further, that if our request asked for in the first resolution be not granted by the supreme chancellor during the recess of the Supreme Lodge, or by special session of the Supreme Lodge, within ninety days from date, then we shall take the privilege of translating such portions of the ritualistic work as will enable us to enjoy our previous privileges abrogated in legislation." And another resolution was also adopted, reading as follows: "Resolved, that, in case no action has been taken by the Supreme Lodge within ninety days from date, then the secretary of this convention shall cause the ritual to be translated, copied, and have one copy forwarded to each lodge." This resolution had reference to the request of the convention for the restoration of the German ritual. A further resolution was passed: "Resolved, that this organization shall be permanent, and that its location shall be in Chicago. That it shall be the duty of the executive officers of the organization to maintain correspondence between the different lodges, and, in case of any difficulty any other lodges may have with their respective grand lodges or the Supreme Lodge, then the organization shall at once employ the most eminent legal counsel, and at once take the matter into court, with the determination that the supreme court of the United States, if necessary, shall finally decide it." A considerable number of German rituals were printed. Afterwards many of them were seized and burned, and the attempt to coerce the society in this respect failed. Wellenvoss was active in the movement and in having the rituals printed in the German language.

At the session of the Supreme Lodge in 1894, a report was made by the supreme chancellor of the conduct of Wellenvoss and others, under the title "Disloyal Past Grand Chancellors"; Wellenvoss having been a past grand chancellor of the order. In this report that officer recommended that steps be taken at once looking to the expulsion or suspension of the past grand chancellors from further membership in the Supreme Lodge. A committee to whom the matter was referred reported that these past grand chancellors were evidently disloyal, and asked the Supreme Lodge to refer the matter to the incoming supreme chancellor, with power to take the

evidence and "to try the past grand chancellors and bring the matter to a legal conclusion." Just before the session in 1896 of the Supreme Lodge the then supreme chancellor took up the matter and appointed a past supreme chancellor to take the evidence and make the investigation in the case. As to Wellenvoss, the report of this officer to the Supreme Lodge session at Cleveland, Ohio, in 1896, disclosed that in his opinion Wellenvoss was still disloyal and insubordinate, and that "he couldn't bring him down at all," and he recommended that he be suspended from the order and his name erased from the membership of the Supreme Lodge. At this meeting Wellenvoss' name was ordered stricken from the list of past grand chancellors, and a communication was ordered sent to the Supreme Lodge of Kentucky, requiring them "to take certain steps under these instructions." Prior to this meeting in 1896 a meeting of the Grand Lodge of Kentucky was held in 1895, at which Wellenvoss was in attendance and undertook to participate in the proceedings, but was objected to because of the charges pending against him, and was refused the right of participation. Wellenvoss thereupon began a proceeding in mandamus to compel the Grand Lodge to recognize his right of membership and participation, but failed in the action both in the circuit court and the court of appeals of Kentucky. From the action of the Supreme Lodge in 1896 above stated, Wellenvoss appealed to the Supreme Tribunal. At its meeting in 1898 that body sustained the appeal and ordered Wellenvoss' name restored to the roll of past grand chancellors. About the close of the session in 1898, upon the announcement of this decision, a resolution was passed "ordering the incoming supreme chancellor to immediately take steps to renew these charges and bring the case before the Supreme Tribunal direct." In October, 1898, the then supreme chancellor filed charges, the first specification being: "That the said Henry Wellenvoss, then and now a member of the Umland Lodge No. 4, a lodge in good standing in the order of Knights of Pythias within the grand domain of the Grand Lodge of Kentucky, did, in violation of his several obligations as a member of the order of Knights of Pythias, and as a past grand chancellor and past supreme representative, attend a meeting of so-called representatives of German lodges of the order of Knights of Pythias, held in the city of Indianapolis, Indiana, on the 12th and 13th days of June, A. D. 1893, which convention was avowedly held for the purpose of resisting the laws, orders, and decrees of the Supreme Lodge in regard to the printing of the ritual of the ranks of knighthood in the English language only." Wellenvoss answered, and a trial was had. The members of the Supreme Tribunal were unanimous in their judgment, and held: "Upon the record we are brought to the conclusion that the said convention of representatives of German lodges held in Indianapolis, Ind., June 12 and 13, 1893, was convened in a spirit of rebellion to the Supreme Lodge and its duly constituted officers, and that such spirit inspired its proceedings; that it was made a permanent organization under the name of the 'National Convention of German Lodges, Knights of Pythias,' of the United States, with all the machinery of a perfectly organized institution, for the very purpose of resisting to the uttermost, through all the civil courts of the land to the one of last resort, the enactments and authority of the Supreme Lodge; that the defendant not only recognized, but affiliated with, said organization, and accepted the position of chairman of its executive board (which was practically the organization itself), and actively co-operated with it in setting at defiance the authority of the Supreme Lodge, and thereby violated the obligations by which he was bound as a Knight of Pythias. He claims (and the record seems to sustain his claim) that he was one of the most conservative of the participants of the Indianapolis convention, and exerted his influence for the furtherance of 'peace and harmony.' We may assume from his subsequent prominent position in the organization that his influence prevailed, and the resolutions which we have quoted were the crystallization of the most moderate counsels. We can only conjecture what were the spirit and sentiments of the extremists with whom the defendant saw fit to cast his lot against the order to which he bound himself by the most solemn obligations. We must also hold that the defendant violated the obligations by which he was bound to the order,

in that he not only connived at the committing of the secret work of the order in writing and printing, but having it published in a manner not authorized by law, but actively participated in it to the extent of assuring Lange of his moral support and advising him how many copies of the ritual to have printed. We therefore find the defendant guilty of violating his obligations to the order, as set out in the first charge of the complaint, and adjudge that he be suspended from the order for the term of two years. The conclusion hereinabove reached renders it unnecessary to, and we do not, decide the other questions presented by the record in this cause."

The judgment was rendered August 5, 1899. During all the time Wellenvoss paid all the assessments upon his benefit certificate, and continued to pay or tender them until his death, February 16, 1900.

Walter P. Lincoln, for plaintiff in error.

O. A. Wehle, for defendant in error.

Before LURTON, DAY, and SEVERENS, Circuit Judges.

DAY, Circuit Judge, after making the foregoing statement of facts, delivered the opinion of the court.

In the view that we take of this case it may be conceded that by the law of the order, binding upon the membership, in order to maintain the rights conferred by the insurance certificate, it was necessary to continue membership in good standing in the subordinate lodge of which insured was a member. It may also be granted that the Supreme Tribunal had the right to try Wellenvoss for the offense of which he was convicted, and that it was of sufficient gravity to warrant a suspension from the privileges of the order for the term of two years within the rules and regulations lawfully enacted. It may also be granted that the various acts of incorporation had only the effect to continue the corporate body as a single existence with its laws and regulations in continual force, except as modified from time to time. These questions have been elaborately argued. In our judgment the case may properly turn on the interpretation of the legal effect of the suspension of Wellenvoss on the right of the beneficiary to recover on his certificate. The rights of such organizations as the Knights of Pythias to control their internal management, and determine for themselves who shall be members of the organization, so far as the fraternal and social features are concerned, is not before us in this case. An examination of the adjudicated cases will show the general disposition of the courts to permit to such bodies full liberty to deal with those features of the organization, and to determine, by tribunals of their own, rights and obligations of membership in these secret and fraternal bodies.

We are dealing in this case, not with these social and fraternal rights and obligations, but with contractual rights under a certificate of insurance upon the life of the insured in favor of the beneficiary who brings this action. In this respect these organizations are business corporations. They do not issue policies of insurance strictly speaking, but the benefit certificate is a contract of insurance none the less, and the assessments are levied in lieu of premiums to keep the contract alive. The corporation agrees, in consideration of the payment of the assessments and the fulfillment of the other requirements, to pay a stipulated sum upon the death of the certificate holder to the

beneficiary named. Bac. Ben. Soc. §§ 3-52. We have, then, to deal with a contract of insurance which provided that Wellenvoss should comply with the laws governing the Endowment Rank, in force or enacted after the issuance of the certificate, and maintain good standing under the laws of the society. The regulation under which Wellenvoss was suspended provided for a hearing and a sentence of expulsion or suspension from the order for a definite period. He was convicted of a violation of his obligation to the order in publishing and printing a ritual in an unauthorized manner. The conviction was under authority of section 405 of the Supreme Statutes of 1894, regulating the insurance branch. Under that section his sentence of expulsion or suspension could only be pronounced after due notice and trial. Its provisions were not self-executing, and such as ipso facto avoid the contract of insurance, as does the nonpayment of dues and assessments. Unless the society instituted proceedings which, upon conviction, would terminate the rights of the member, he continues in good standing. Upon the insurance contract the effect of such conviction is to end his right of recovery under his insurance certificate, or to suspend it, if suspension is the sentence imposed. In other words, it works a forfeiture of his right of insurance in whole or during the period of suspension. Conceding the right of the society to pass a judgment of this character, which shall work a forfeiture of the contract of insurance, as well as terminate the social and fraternal rights, of the member, are there no limitations upon the exercise of this right? Forfeitures are not favored in the law, and he who would insist upon the exercise of the right must act in strict accordance with the terms of the contract which gives the privilege. It has been repeatedly held in ordinary contracts of insurance that the receipt of a premium after the accruing of a cause of forfeiture of which the company has knowledge is a waiver of the right to insist upon it. *Insurance Co. v. Raddin*, 120 U. S. 196, 7 Sup. Ct. 500, 30 L. Ed. 644. We perceive no good reason why the general principles of the law governing forfeiture should not apply to the insurance contracts of benefit associations. Bac. Ben. Soc. § 431. In *Stylow v. Insurance Co.*, 69 Wis. 224, 34 N. W. 151, 2 Am. St. Rep. 738, Judge Taylor, speaking for the court, says:

"Where no fraud has been practiced by the insured in concealing his state of health at the time the payments are made, and the company receives such payments out of time, when it might refuse payment and declare the insurance forfeited, it cannot accept the money, and keep it, and still insist upon a forfeiture."

In *Modern Woodmen of America v. Jameson*, 48 Kan. 718, 30 Pac. 460, it was held that the forfeiture of such contracts was not to be favored.

In *Supreme Lodge v. Kalinski*, 163 U. S. 289, 16 Sup. Ct. 1047, 41 L. Ed. 163, the court said:

"Aside from this, the continued receipt of assessments upon Kalinski's certificate up to the day of his death was a waiver of any technical forfeiture of the certificate by reason of the nonpayment of the lodge dues. Granting that the continued receipt of premiums or assessments, after a forfeiture has occurred, will only be construed as a waiver when the facts constituting a forfeiture are known to the company (*Insurance Co. v. Wolff*, 95 U. S. 326,

24 L. Ed. 387; *Bennecke v. Insurance Co.*, 105 U. S. 355, 26 L. Ed. 990), this is true only of such facts as are peculiarly within the knowledge of the assured. If the company ought to have known the facts, or with proper attention to its business would have been apprised of them, it has no right to set up its ignorance as an excuse."

These contracts are relied upon as a means of providing for wife and children. In many of these societies only such as are near in relation or kinship can be beneficiaries. If the right to enforce them is to be taken away, good faith requires such action to be taken with reasonable promptness, that the insured may not, by the failure of the society to assert the right, be lulled into assurance that the fault is condoned, so far, at least, as his insurance is concerned, and the sum intended will be available to his beneficiaries in the event of his death. If this is not law, such associations, with the full knowledge that a cause of forfeiture has arisen, may go on indefinitely levying and collecting assessments, until the assured by reason of age or disease can no longer procure a contract of insurance in favor of those who have a natural claim upon him for such provision. While these societies are peculiar in their organization, and are conceded the fullest right to control their membership and regulate for themselves their internal affairs, as insurance companies we perceive no reason why they should not be held to act upon those principles of equity and fair dealing which the law requires of other companies whose business is that of insurance. Nor is this view, so entirely just in itself, lacking authority for its support.

In *Nib. Ben. Soc.* (2d Ed.) § 565, the author says:

"Knowledge on the part of the society of a breach of one of the conditions of the contract by the member, and the subsequent collection of assessments, is a waiver of the right to forfeit the contract for that cause."

In *Bac. Ben. Soc.* § 431, the rule is thus stated:

"But it seems that good faith would require the company, when it becomes aware of a right of forfeiture, to avail itself of it within a reasonable time, and if, after such knowledge, it collects a premium, it should be held to have waived forfeiture."

This seems to be a reasonable statement of the rule. Applying it to the facts in this case, what is the result? Let it be assumed that Wellenvoss, by his participation in the movement of June, 1893, had so far violated the obligations of the order, in participating in and directing the movement to print the ritual in defiance of the order of the duly constituted authorities of the society, as to justify proceedings for his expulsion or suspension, and the consequent loss of his insurance, no such action was taken. The first action of the association was in 1894, when the report of the supreme chancellor was filed. The recommendation of that officer was that steps be taken for the expulsion or suspension of the offending officers from further membership in the Grand Lodge. No steps were then taken to expel him from the order or suspend his membership, and none were suggested. In 1896, when the report of the past supreme chancellor was made who had investigated the conduct of the recalcitrant officers, his recommendation as to Wellenvoss was that he be suspended from the order, and his name be erased from the membership of the Supreme Lodge. Wellen-

voss' name was stricken from the list of past grand chancellors. No proceedings were then instituted to expel him from the order. From this decision Wellenvoss appealed to the Supreme Tribunal, and that body in 1898 restored his name to the roll of past grand chancellors. Upon hearing of this decision, upon the motion of certain members of the Supreme Lodge, it was ordered that charges be filed before the Supreme Tribunal, which resulted in the conviction of Wellenvoss of violation of his obligations to the order in participating in the movement for the German ritual in 1893, and his suspension for two years from the order, with the consequent forfeiture for that period of all rights under his insurance certificate. During this suspension, and within a few months, Wellenvoss died. He was sick with a fatal disease when he was suspended. During all these years, and until official notice of his suspension, the society continued to receive his assessments. When suspended, he was no longer a fit subject for insurance. He could not pass a physical examination. He was likely to soon pass away, and did die long before the period of his suspension had passed. Not only had the society failed to take any action looking to suspension or expulsion for these five years, but it received his assessments for that entire period. It sought to punish him for the offense committed by striking his name from the list of past grand chancellors, and it was only when this action was reversed by the Supreme Tribunal that the proceeding was instituted which resulted in his suspension. It may be true that no statute of limitations would prevent the society from ridding itself of undesirable members, and we are not here dealing with the right of the society to exclude a member from its social and fraternal privileges. We have before us a contract of insurance, which, assuming it to be subject to forfeiture, was so because of facts known to the society for five years without effectual steps to avail itself of the right, receiving payment upon it periodically, and declaring a forfeiture after the assured had reached a state of health preventing the purchase of other insurance. Upon the plainest principles of justice and settled law applicable to such a situation, we think the right of forfeiture, if it existed, is waived as against the beneficiary.

It is urged that Wellenvoss should have sought a remedy within the society for his suspension, and that class of cases is cited which hold that a member of a fraternal organization who claims to have been wrongfully deprived of membership must seek the redress provided for in the order to which he belongs. If this doctrine can have application to a case like the present, it is to be noted that Wellenvoss was convicted by the highest tribunal of the order. The judgment was unanimously rendered by that body. It would have been vain to have filed a petition for rehearing, which was the only recourse left to the assured. *Loubat v. LeRoy*, 40 Hun, 546-549.

It is further contended that by the terms of the certificate of insurance Wellenvoss' beneficiary could only recover in the event that he continued in good standing until his death. It certainly can be no defense to an action on the certificate that the society wrongfully deprived the member of "good standing." If that be so, the unwarranted action of the society might be made to protect it from just liability.

This would be to permit it to take advantage of its own wrong. Well-
 envoss did all that he could do to maintain his contract rights by a
 tender of the assessments after the society refused to receive them.

We find no error in the direction of a verdict for the plaintiff below.
 Judgment affirmed.

BALTIMORE & O. R. CO. et al. v. WABASH R. CO.

(Circuit Court of Appeals, Seventh Circuit. November 11, 1902.)

No. 863.

1. FEDERAL AND STATE COURTS—PRIORITY OF JURISDICTION—RULE STATED.

It is the settled rule that, when a state court and a federal court may each take jurisdiction of a matter, the tribunal whose jurisdiction first attaches holds it, to the exclusion of the other, until its duty is fully performed, and the jurisdiction involved is exhausted. While such rule is not limited to cases in which property has actually been seized under process from one court before suit is instituted in the other, it is limited to actions which deal either actually or potentially with specific property or objects, and does not apply to actions strictly in personam.

2. JURISDICTION OF FEDERAL COURTS—SUIT TO ENFORCE DECREE OF STATE COURT.

A federal court has jurisdiction, where the requisite diversity of citizenship exists between the parties to a suit, to enforce a decree of a state court by which a railroad company has acquired the right in statutory proceedings to construct a grade crossing over the tracks of another company, by enjoining the latter from placing or maintaining obstructions in the way of such crossing; and the right to grant such relief is not affected by the fact that an appeal from such decree is pending in an appellate court of the state, where, under the statute, it does not operate as a supersedeas,—the court having power to so shape its decree that the injunction will be effective only so long as the decree of the state court shall remain in force.

3. PARTIES—DENIAL OF APPLICATION TO BE MADE PARTY.

Such a suit is, in effect, one to enjoin a continuing trespass on the easement granted by the state court; and, where the company committing such trespass is a lessee in possession and operation of the road over which the crossing is to be made, its lessor is not an indispensable party, and will not be permitted to become a party for the purpose of ousting the court of jurisdiction.

Appeal from the Circuit Court of the United States for the District of Indiana.

The Wabash Railroad Company, the appellee, acquired the right to construct a railway from New Haven to Butler, Ind. The line crosses a railway in possession of and operated by the Baltimore & Ohio Railroad Company, one of the appellants, at a certain point in De Kalb county. Being unable to agree with respect to the point and manner of crossing and the damages, on August 28, 1901, the Wabash Company filed its "Instrument of Appropriation," under the statutes of Indiana, for a grade crossing, making the two companies, appellants here, parties thereto. Pending the proceedings an agreement was reached between the parties to the effect that the judge should appoint three commissioners to ascertain and report whether an overgrade crossing at the point in question was reasonable and practicable, and whether a crossing at grade should be established, and to assess the damages upon

¶ 1. Conflicts of jurisdiction between federal and state courts, see note to Louisville Trust Co. v. City of Cincinnati, 22 C. C. A. 356.

the theory of an interlocking plant being put in, used, and maintained by the Wabash Company under plans and specifications to be submitted to and approved by the auditor of the state. Commissioners were appointed by the court, who reported that an overgrade crossing was impracticable, and reported in favor of the construction of a grade crossing, assessing the damages at \$12,000. Upon that report, on the 19th of October, 1901, the court decreed the Wabash Company "to have a right to and to be possessed of a right to such grade crossing, and to the rights and privileges appropriated in said instrument of appropriation at such place." The damages assessed were paid into court. On October 30th plans and specifications for an interlocking system and plant at such crossing were approved by the auditor of the state, of which the appellants were duly notified. The Wabash Company was about to put an interlocking plant in place, but was notified on the 10th of December, 1901, by the Baltimore & Ohio Railroad Company, that it would not permit a grade crossing. At that time, there being only two tracks, 8 feet apart, the latter company changed the grade of one of the tracks so as to give it a super-elevation of 4 inches over the grade of the other track, moved the south track a distance of 20 feet, and between the two tracks constructed a third track, and placed thereupon engines and cars at that crossing, detaching the middle track from each of the other tracks; thus obstructing the making of the grade crossing. Both companies, appellants here, appealed from the decree of appropriation to the appellate court of the state of Indiana, which appeal is still pending. On the 14th of December, 1901, the Wabash Company, which is a corporation of the state of Indiana, filed its bill in the circuit court of the United States for the district of Indiana, seeking to enjoin the Baltimore & Ohio Railroad Company, a corporation of the state of Maryland, from resisting the making of the grade crossing, and requiring it to remove the obstruction, to rearrange the level of the tracks, and restore them to the condition they were in at the time of the decree. Upon the 18th of December the Baltimore & Ohio & Chicago Railroad Company, a corporation of the state of Indiana, presented its petition seeking to be made a party defendant; setting forth that it was the owner of the railway, and that the Baltimore & Ohio Railroad Company is the owner of a part of its capital stock. But the court refused to allow the petition to be filed, to which ruling it excepted. And on that day, upon bill and answer, the court enjoined the Baltimore & Ohio Railroad Company, substantially as prayed for in the bill, and thereupon the decree or order allowing the injunction is brought by appeal to this court for review upon a joint and several appeal by both companies appellant.

W. H. H. Miller, for appellants.
Addison C. Harris, for appellee.

Before JENKINS and GROSSCUP, Circuit Judges, and SEAMAN, District Judge.

JENKINS, Circuit Judge (after stating the facts). It is settled that, when a state court and a court of the United States may each take jurisdiction of a matter, the tribunal whose jurisdiction first attaches holds it, to the exclusion of the other, until its duty is fully performed, and the jurisdiction involved is exhausted. *Harkrader v. Wadley*, 172 U. S. 148, 19 Sup. Ct. 119, 43 L. Ed. 399; *Farmers' Loan & Trust Co. v. Lake Street El. R. Co.*, 177 U. S. 51, 20 Sup. Ct. 564, 44 L. Ed. 667. We have followed this rule, declaring "that the court which first obtains possession of the res or of the controversy, by priority in the service of its process, acquires exclusive jurisdiction for all the purposes of a complete adjudication." 505,000 Feet of Lumber, 24 U. S. App. 509, 517, 12 C. C. A. 628, 65 Fed. 236. The rule is not only one of comity, to prevent unseemly con-

licts between courts whose jurisdiction embraces the same subject and persons, but between state courts and those of the United States it is something more. "It is a principle of right and law, and therefore of necessity. It leaves nothing to discretion or mere convenience." *Covell v. Heyman*, 111 U. S. 176, 4 Sup. Ct. 355, 28 L. Ed. 390. The rule is not limited to cases where property has actually been seized under judicial process before a second suit is instituted in another court, but it applies as well where suits are brought to enforce liens against specific property, to marshal assets, administer trusts, or liquidate insolvent estates, and in all suits of a like nature. *Farmers' Loan & Trust Co. v. Lake Street El. R. Co.*, supra; *Merritt v. Steel Barge Co.*, 24 C. C. A. 530, 79 Fed. 228, 49 U. S. App. 85. The rule is limited to actions which deal either actually or potentially with specific property or objects. Where a suit is strictly in personam, in which nothing more than a personal judgment is sought, there is no objection to a subsequent action in another jurisdiction, either before or after judgment, although the same issues are to be tried and determined; and this because it neither ousts the jurisdiction of the court in which the first suit was brought, nor does it delay or obstruct the exercise of that jurisdiction, nor lead to a conflict of authority where each court acts in accordance with law. *Stanton v. Embrey*, 93 U. S. 548, 23 L. Ed. 983; 8 Rose, Notes, 1010. The doctrine is lucidly stated by Judge Thayer in *Merritt v. Steel Barge Co.*, supra.

Subject to the conditions stated, where jurisdiction, concurrent with the state court, exists in the federal court, parties have the right, the necessary diversity of citizenship existing, to invoke that concurrent jurisdiction, and it may not be denied them. We have been thus careful to state the limitations which hedge about the federal jurisdiction in respect to subjects which are also within the jurisdiction of state courts because it is all important that conflicts of jurisdiction between courts of different sovereignties, acting within the same plane, should be avoided. Applying these principles to the case in hand, it remains to be considered whether the present case is one in which federal jurisdiction may properly be invoked. The suit is one to restrain continuing trespasses by the Baltimore & Ohio Railroad Company, whereby the Wabash Company is prevented from the assertion of the right decreed by the state court. In its broadest aspect, it is a suit to enforce the decree of the state court, not to limit or restrain it. A creditors' bill may undoubtedly be enforced in a federal court, based upon the judgment of a state court, and a creditors' bill is merely an equitable execution. So, also, an action of ejectment will lie in the federal court, the necessary diversity of citizenship existing, upon a title derived through a state court. It would be no answer to such an action to say that the state court could have enforced its decree and given the party possession. In the present case the decree of the state court adjudged an easement in the locus in quo to the Wabash Company. Its rights were determined by that decree. This proceeding is not one to acquire an easement, or to perpetuate or condemn an easement, but is a bill in the nature of an action to stay trespass commit-

ted upon the easement acquired by the Wabash Company under the decree in question. If that decree were unappealed and unassailed, there could, we think, be no question that a federal court—its jurisdiction otherwise being conceded—could entertain a bill to enforce the decree, and to deliver possession pursuant to the decree, and to enjoin interference and obstruction, because such a proceeding is in aid of, and not in opposition to, the adjudication of a state court. It is said, however, that the decree of the state court was, prior to the filing of this bill, removed by appeal into an appellate court, and is there pending; but the appeal taken under the statute of Indiana does not operate as a supersedeas, nor in any way delay or prevent the enforcement of that decree pending the appeal. The Wabash Company, notwithstanding the appeal, could in a state court have enforced the decree. Is there any reason why it might not resort to the federal court for the same purpose, and will the action of the federal court be an interference leading to a conflict of jurisdiction? It is alleged that such might result if the federal court should decree for the Wabash Company, place it in possession, and subsequently the appellate court of Indiana should reverse the decree of the De Kalb circuit court, which adjudged the decree, and that then the Wabash Company could claim possession under the decree of the federal court, and upon decree of ouster by the state court an unfortunate conflict of jurisdiction might be projected. Such supposed possible conflict is fanciful, not real. It must be assumed that the federal court will proceed according to law, and will conform its orders and decrees in such way that no possible conflict can arise. The order here appealed from is a temporary restraining and mandatory order of injunction to prevent trespass upon the decreed rights of the Wabash Company, and pending the suit the court below is fully competent to set aside or to modify the order as the emergencies of the case may require; and it undoubtedly would so act so soon as it was advised of a reversal of the decree of the De Kalb circuit court. So, also, if this suit should go to final decree before action of the state appellate court, the proper decree to enter, and which unquestionably the court below would enter, would not be an absolute decree, but would restrain the commission of the trespasses, and the interference with possession by the Wabash Company, so long as the decree of the De Kalb circuit court should remain in full force and virtue. The decree so framed would, by force of its own terms, lose efficacy upon reversal of the decree of the De Kalb circuit court, and no conflict of jurisdiction could arise. We are anxious and should strive to avoid all possible and unnecessary conflict between federal and state courts, but we are not at liberty to deny jurisdiction when it is rightly invoked.

The application of the Baltimore & Ohio & Chicago Railroad Company to be made a party to this suit was properly denied. The road was in the possession and operation of the Baltimore & Ohio Railroad Company, and the latter company only had committed the trespass. The Baltimore & Ohio & Chicago Railroad Company was a corporation of the state of Indiana, and sought to be made a party to the suit manifestly and only for the purpose of ousting the federal

jurisdiction. It was not an indispensable party to the suit, since, so far as the record shows, it had no part in the commission of the trespasses charged. It cannot be permitted to obtrude itself into a litigation to defeat the jurisdiction of the court.

The decree or order appealed from is affirmed.

SUPREME COUNCIL AMERICAN LEGION OF HONOR v. ORCUTT.

(Circuit Court of Appeals, Sixth Circuit. January 6, 1903.)

No. 1,099.

1. FRATERNAL INSURANCE—ACTION ON CERTIFICATE—PLEADING.

An allegation in a petition on a benefit certificate in a fraternal order that the insured "at all times from and after his admission to membership to said defendant, until up to the time of his death, promptly and punctually paid all assessments, dues, charges, and demands levied, charged, and demanded of him by said defendant," is sufficient, on demurrer, as an allegation that such payments were made to the proper officer of defendant.

2. APPEAL—REVIEW—ERROR NOT PRESUMED.

On an assignment of error for admitting the answer of a witness claimed to have been incompetent, where the answer is susceptible of two constructions, one of which renders it competent, it will be given such construction in support of the ruling, as error must affirmatively appear.

3. FRATERNAL INSURANCE—RULES GOVERNING CONTRACTS.

A fraternal order or association has the power and the right to make and enforce rules in respect to the discipline and social relations of its members, and to prescribe their conduct toward the association and each other; but when it enters into contractual relations with them, as by the issuance of benefit or insurance certificates, it assumes obligations which are subject to the rules and principles which govern such contracts in general, and which are enforceable in the courts.

4. SAME—METHOD OF PAYING ASSESSMENTS—ESTOPPEL.

A by-law of a fraternal insurance order in relation to the payment by members of assessments on their benefit certificates, providing that "every member of the order shall pay to the collector of his council," is not to be so rigidly construed as in all cases to preclude payment through others; and where payments were made by certain members for more than two years to one authorized by the head of the order to receive the same and forward them to the collector, and such payments were received without objection and paid into the general treasury by the collector of the subordinate council, the association must be presumed to have known of and ratified such method of collection, and it could not lawfully suspend a member's insurance because of a delay by its agent in forwarding an assessment which was paid to him by such member in accordance with the custom and within the required time.

5. SAME—WRONGFUL SUSPENSION OF MEMBER—WAIVER OF RIGHTS.

Where a member of a fraternal order was wrongfully suspended, and thereafter received no notice of assessments due on his benefit certificate, his rights were not prejudiced by the failure to tender such assessments, nor waived by his making application for reinstatement.

In Error to the Circuit Court of the United States for the Northern District of Ohio.

Henry & Robert Newbegin (Alfred J. Carr, of counsel), for plaintiff in error.

F. W. Sturdivant (Alex. L. Smith, of counsel), for defendant in error.

Before LURTON, DAY, and SEVERENS, Circuit Judges.

SEVERENS, Circuit Judge. This was an action brought by the plaintiff below to recover from the plaintiff in error here the amount claimed to be due upon a contract of insurance upon the life of her husband, Milton E. Orcutt, called in the record a "benefit certificate," in the sum of \$5,000. The certificate was issued in 1881, and read as follows:

"This certificate is issued to said companion as an evidence of the fact in it contained, and as a statement of the contract existing between said companion (Milton E. Orcutt) and the Supreme Council American Legion of Honor. In consideration of the full compliance with all the by-laws of the supreme council now existing or hereafter adopted, and the conditions herein contained, the supreme council hereby agrees to pay James A. Orcutt, father, five thousand dollars, upon satisfactory proof of the death, while in good standing upon the books of the supreme council, of the companion herein named, * * * subject, however, to the conditions, restrictions, and limitations following: * * * That said companion shall have paid all assessments called, to the benefit fund, within the time and in the manner required by the by-laws of the supreme council in force at the time of the issuance of this certificate, or as the same may be hereafter amended. That this benefit certificate is issued by the Supreme Council American Legion of Honor, and accepted by the companion herein named, for himself and for his beneficiary, upon the express condition and agreement that, in case of any false or fraudulent statement or misrepresentation or violation of any of the covenants herein contained, the same shall be void."

James A. Orcutt, the beneficiary, died December 29, 1891. The insured was married to the plaintiff October 28, 1896, and they lived together as husband and wife until he died, September 1, 1898.

A by-law of the association provided as follows:

"In the event of the death of all beneficiaries selected by the member, before the decease of such member, if no other and further disposition thereof be made in accordance with the provision of these by-laws, the benefit shall be paid to the widow and children of the member in equal shares."

There was a trial by a jury, and a verdict and judgment for the plaintiff in the sum of \$5,748.67.

At the time the certificate was issued, Orcutt, the insured, was a member of a subordinate council at Defiance, Ohio. By a rule of the association, whenever the number of members in a subordinate council was reduced below 11, the council would become defunct, and the members were to be transferred to some other council. In 1893 the number of the Defiance council was reduced below 11, and continued to diminish until March 7, 1895, when the supreme secretary wrote a letter to Orcutt, stating that the charter must be surrendered, and recommending him to communicate with the secretary of the grand council and obtain a transfer of membership. The Defiance members continued members at large until April 8, 1895, when they were transferred to Alpha Council, No. 1, whose office was at Boston, Mass., of which, the petition alleges, Orcutt continued a member until

the time of his death. It is also averred that he paid all assessments and dues from the date of his certificate. To a petition alleging substantially the foregoing facts, the defendant filed a general demurrer. This was overruled, and the defendant answered, denying the averments of the petition, and setting up the defense upon which reliance is mainly placed, namely, that the insured neglected to pay his assessment for the month of July, 1897, and was thereupon, for that cause, duly suspended in accordance with the rules of the association, and was never thereafter reinstated.

The order of the court overruling the demurrer is challenged by an assignment of error upon the grounds that it does not appear by the petition that any notice was given to the association of the death of James A. Orcutt, the original beneficiary, or of the plaintiff's marriage to the insured; that she sues as his representative; and that there is no direct allegation that the insured paid to the collector of Alpha Council, No. 1, the assessments due after the transfer to that council. But it does not appear that notice of the death of the original beneficiary was required by any rule or by-law of the association. The widow does not sue as representative of any one, but as the widow of the deceased, who is constituted the beneficiary by the by-law of the association above set forth; and the allegation of the petition is that the insured, "at all times from and after his admission to membership to said defendant until up to the time of his death, promptly and punctually paid all assessments and dues, charges and demands, levied, charged, and demanded of him by said defendant, and by said subordinate council thereof, such as he was required to pay in accordance with its rules and by-laws, as the same became due and payable." This allegation imports that he paid his assessments and dues to the association, and certainly is sufficient upon general demurrer. The demurrer was properly overruled.

Upon the trial it appeared that the assessment for the month of July, 1897, was, by the rules of the association, required to be paid before the end of the month; that the insured paid it to one Daoust, the cashier of a bank at Defiance, on or before the 20th of July, 1897, but that Daoust did not forward it to the collector of Alpha Council, No. 1, until the 5th of August following; that the collector was required to make his returns to the supreme treasurer for the month of July on August 12th; that he reported the receipt of Orcutt's July assessment as not having been paid until August; that Orcutt was thereupon suspended, and the check was returned to Daoust; that he made application for reinstatement on August 23, 1897; that his case was referred to the medical examiner, who reported his physical constitution not acceptable, and thereupon the petition for reinstatement was disallowed; that Orcutt was at the time of his suspension in failing health; and that he died in September of the following year. There was testimony tending to prove that in the spring of 1895 Mr. Daoust received a letter from the supreme commander of the order authorizing him to collect the assessments due from the members at Defiance, and that he soon afterwards began to receive the statements of the assessments monthly, with blank receipts for each member; that these statements and receipts were received in

envelopes bearing the direction, "Return to F. O. Downes, Alpha Chapter, No. 1;" that he collected the assessments and sent them in one check monthly to the address at Boston; that he sent them during the month in which they were payable, sending back the blank receipts for signature, which came back signed during the first half of the ensuing month, and were by him delivered to the members, and that this mode of doing business continued until the payment of the assessment for July, 1897; that the sum due for Orcutt's July assessment was in his hands as early as the 20th of that month, but that, on account of his own absence and oversight, he did not send in the assessments for July until after the expiration of the month. Testimony to this effect was given by Daoust. But in the course of his examination a ruling was made which is the subject of an assignment of error. While he was testifying about receiving the letter from the supreme commander directing him to collect the assessments,—it having been shown that the letter was lost or could not be found,—the course of examination was as follows:

"Q. You may state, if you can, what the letter said, or what the contents of that letter were, as near as you can recollect? (Objection by counsel for defendant on the ground that the loss of the letter is not proved, that the question calls for incompetent and irrelevant evidence, and that no evidence has been given showing that Supreme Commander Gwinnell, had authority to bind the defendant by his action.) The Court: I think the loss is sufficiently shown. The objection will be overruled. (Whereupon counsel for defendant excepted to the ruling of the court.) Q. You may answer the question, Mr. Daoust. A. I don't remember the wording, but it was authorizing me— The Court: No, no. Q. Give in substance what he said to you? A. I don't remember the wording. Q. We don't ask you for the exact wording. We ask you for the substance of the wording. The Court: You must not give the interpretation by saying they authorized— A. To collect these three men, and remit to Council No. 1, in Boston. (The last three answers objected to by the defendant on the grounds that they state a conclusion, instead of the purport of the letter; and defendant asked the court to rule out the same, which request was overruled by the court, and exceptions taken by the defendant.)"

It is urged that the last three answers stated a conclusion, and should have been ruled out. The contention is that the last answer, "To collect these three men, and remit to Council No. 1, in Boston," should be construed as connected with the former words, "authorizing me"; and it is possibly susceptible of that construction. But we think the more reasonable construction is that the witness was proceeding to state the substance of the letter. He had been expressly warned that he was not to give his interpretation, but to give the substance of the wording, and it is quite clear that the court understood him to be stating the substance, and not the interpretation. Error will not be presumed. The burden of showing it must rest upon the party complaining. We think the exception should not be sustained.

We have not given all of the testimony. There was some from which the inference might be drawn that Daoust was acting as the agent of the members in forwarding their assessments; but it is not of a decisive character, and the jury were authorized to draw their own conclusion as to whether Daoust was acting as the agent of the association or of the members at Defiance. The testimony was not so clearly one-sided that the question should have been taken from them and de-

cided by the court, and in such case the verdict must be respected. This is decisive of the main question in the case.

Counsel for the defendant prayed for peremptory instruction that the plaintiff was not entitled to recover. The court refused to give such instruction, and the defendant excepted. In support of the assignment of error in this refusal, it is urged:

1. That Orcutt was not in fact a member in good standing at the time of his death. But if the fact be, as the jury found, that he was suspended without cause, it was not competent for the defendant to put its own wrongful action forward as a defense. We do not question the power and right of the association to make and enforce such rules and regulations in respect to the discipline and social relations of its members, and to prescribe the conduct of its members with reference to the association and between its members. All that must be rightfully remitted to its jurisdiction. But when, as here, it enters into contract relations with its members, it assumes obligations which become subject to the rules and principles which govern contracts in general. It cannot be admitted that a contract entered into with so much solicitude on the part of the member, and kept alive by frequent financial sacrifices during one's whole life, is subject to be disappointed at the end by the capricious and wrongful conduct of the association. It is impossible to suppose that the parties entering into such contract intended that its obligation should depend upon the willingness of the insurer to perform it. On the contrary, it is a perfectly just and reasonable presumption that the insured relied upon the expectation that, if he performed his part of the contract, the association would deal with him accordingly, and, when its time should come, it would perform its part in good faith. The association knew that the insured expected this, and must be held to have accepted this expectation as the measure of its own undertaking. To take from under him his standing ground, and then, because he had lost it, deny him the benefit of its promise, is tantamount, at least, to a point-blank refusal, without such preparation for it. And how shall the validity of the refusal, and of the reason for it, be determined? Unless this may be done by the courts of justice, there is no way of enforcing the contract, and it comes to naught.

2. It is further urged that the insured forfeited his rights by his failure to pay the assessment in accordance with by-law 62. This by-law contains nothing new. Stress is laid upon the language, "Every member of the order shall pay to the collector of his council," and it is contended that the supreme commander had no authority to appoint a collector at Defiance; that, under the by-laws of the association, his authority to appoint a collector there expired when the members were transferred to Alpha Council, No. 1; and that thereafter the members should have paid directly to the collector of that council. It may admit of question whether the language above quoted from this by-law is to be so rigidly construed as to require that the money should be paid directly to the collector himself. The substance is that he is to collect the assessments, as his title implies. Circumstances might arise which would require that he should do it by the hand of another. Be that as it may, it appeared by uncontradicted evidence that the

method of collecting the assessments begun in the interim was continued after the transfer for more than two years, down to the time of the suspension, during which period from 25 to 30 assessments were collected and paid over by Daoust to the collector at Alpha Council, No. 1, without any objection or question made by that collector or any officer of the association; and no objection was made on that ground, at the time it was received, to the collection made by him of the assessment for July, 1897. None of the previous collections were offered to be returned. Since a corporation can only act by its agents, we think it should be imputed to the corporation, after so long a period, that it had knowledge of the course of business pursued by them, and that a party dealing with it would have the right to suppose that it was sanctioned. The association received and kept the assessments collected in this way. A corporation, as well as private individuals, must, in the interest of the public, be held to know, at least within some reasonable time, how its business is being carried on, and be estopped from denying that it had knowledge of and assented to the means by which it is done. A single incident might not be sufficient, or a few occurring within a short period. *Mahoney Min. Co. v. Anglo-Californian Bank*, 104 U. S. 192, 26 L. Ed. 707; 1 *Mor. Priv. Corp.* § 509. It may be that, if these assessments had belonged to the subordinate council, other reasons might have force; but here they were all due to the association. They were received into the general treasury, and were retained by the defendant. The collector, in what he did, was acting, not as the agent of the subordinate council, but as the agent of the association itself.

That the insured did not tender subsequent dues and assessments, or claim the privileges of a member, is of no moment. He had no notice of any such levies, and it would have been a vain thing for him to make such tender or to claim his privileges. Nor did his claim to be reinstated constitute a waiver of his right. That was an obvious and proper way to have the wrong undone. The defendant's refusal was a repetition of the wrong. The association was in no wise prejudiced by those proceedings, and is in no position to claim that the plaintiff surrendered a valuable right. *Association v. Hamlin*, 139 U. S. 297, 11 *Sup. Ct.* 614, 35 L. Ed. 167.

Questions subordinate to those already considered are presented by the record, but they are controlled by what we have said. There are no others which seem to require discussion.

There was no error in the charge of the court which, in the view we have taken of the case, injuriously affected the defendant.

The judgment is affirmed.

CHINA & JAPAN TRADING CO. v. DAVIS et al.

(Circuit Court of Appeals, Fifth Circuit. December 16, 1902.)

No. 1,192.

1. SALES—CONTRACT—ACCEPTANCE OF OFFER.

Plaintiff, a cotton exporter, instructed defendants, cotton buyers, to make engagement of freight room simultaneously with sales to plaintiff. Defendants telegraphed an offer of cotton, saying nothing as to freight room, which was accepted by plaintiff by telegraphing, "The offer is accepted * * * steamer space to Japan," and by writing, "Our acceptance was conditioned upon your fixed freight engagement with the steamer space secured to Japan. * * * We cannot take the risk of having cotton held up by the railroads." Later, on learning that freight room had not been secured, plaintiff wrote: "We are not pleased with your carelessness in the matter of freight. * * * You had our letter of general instructions, * * * in which it was specifically stated that freight engagement must be made at the time of selling us the cotton. * * * We are at a loss to see why you should have run this risk." Defendants then wrote, canceling the contract, and more than two months later plaintiff denied receiving this letter, and insisted on performance. Meanwhile the price of cotton had steadily advanced. *Held*, that there was no such unconditional acceptance by plaintiff of the offer of sale as would consummate the contract and sustain plaintiff's action for breach.

In Error to the Circuit Court of the United States for the Eastern District of Texas.

The China & Japan Trading Company filed suit against C. G. Davis & Co. alleging that Davis & Co. had sold to it 500 bales of cotton at a stated price, and that Davis & Co. refused to deliver the cotton, to plaintiff's damage \$6,000. Davis & Co. answered that the contract was never completed. The China & Japan Trading Company was a corporation located in New York and engaged in exporting cotton to Japan and China. C. G. Davis and J. A. Smith, composing the firm of C. G. Davis & Co., were cotton buyers in Pittsburg, Tex. It appears that the parties had been dealing together during the cotton season of 1898, and on July 11, 1899, the China & Japan Trading Company addressed two letters to Davis & Co., explaining the conditions on which they would buy cotton for export. The opening sentence of one letter is as follows: "We shall expect you to make your engagement of freight room simultaneously with your sales to us, covering through shipment and transshipment to destination." "Shipment must be made within the time contracted for; neither earlier nor later." On August 18th Davis & Co. sent this telegram: "We offer f. o. b. and freight 500 bales middling at 6 1-8. Oct.-Nov. or Nov.-Dec. shipment." The trading company replied as follows: "The offer is accepted. 500 bales middling at 6 1-8. Cost and freight. Oct.-Nov. shipment. Steamer space secured to Japan." On the same day the trading company wrote, confirming the purchase, and in the letter stated: "Our acceptance was conditioned upon your fixed freight engagement with the steamer space secured to Japan, which you will understand in the light of last year's experience. We cannot take the risk of having cotton held up by the railroads, and shipped to the Pacific coast at their convenience." Before the last letter was received by Davis, he had written on August 19th as follows: "Inclosed please find copy of telegrams exchanged resulting in sale to you of 500 bales, for which sales note herewith. We are now at work trying to engage the room for same, which we shall no doubt succeed in doing within the next few days. Last year we had some difficulty in securing the requisite room to cover our shipments, and in this connection we would ask if you could not be of some assistance to us should we encounter the same difficulty this season. You are large shippers over the Pacific S. S. lines, and it strikes us that you could possibly obtain room where we cannot.

There will be several vessels out of Galveston to Japan via Suez. Will it be agreeable to you to ship any of your cotton by this way?" On August 22d the trading company replied as follows: "We are surprised to learn that you made this sale to us without having freight engagement in hand, and that in the very trying position of the freight market now you are short room. With every desire to help you, we find ourselves quite powerless. * * * Noting your suggestion to ship via Suez, we remind you that this route is more expensive to us in marine insurance and interest, and we must charge you 1 per cent. allowance if you make that shipment. We will accept from you on this contract October-November shipment by way of Galveston or New Orleans on a steamer direct to Japan, not by way of New York or European ports, if you will make us this allowance. Let us know what arrangement you make." To this Davis & Co. replied August 25th: "In reply to your valued favor of the 22d will say we have the promise of room for 500 bales sold you, and believe we will get it. Our inquiry as to Gulf shipment was made for our information. The freight via this route is against us by 50 cts. a bale, and to allow you one per cent. additional would be quite a hardship on us. If, however, we should be compelled to ship that way, will stand the difference rather than fail on our contract." The trading company replied on August 28th, expressing surprise that freight by the Gulf should be higher, and then stated: "We are not pleased with your carelessness in the matter of freight on this lot of cotton. You had our letter of general instructions before you, in which it was specifically stated that freight engagements must be made at the time of selling us the cotton. With this warning, and the experiences of last year fresh in mind, we are at a loss to see why you should have run this risk." C. G. Davis testified that he wrote the following letter to plaintiff on the 2d of September, 1899: "We note contents of your valued favor of the 28th of August. In view of the fact that you consider our sale to you based upon condition that freight has been engaged for same, and as you express yourself as not pleased that this condition has not been complied with in this instance, we hereby cancel the same. We do this rather than have any dissatisfaction about the matter. In future we will confine our offers to you strictly in accordance with the terms of the contract, as we see that you are disposed to exact the terms thereof very rigidly. Such letter was addressed to plaintiff, and stamped, and placed in the post office at Pittsburg, Texas, on September 2, 1899, in an envelope with our address, and a request to return printed on it. The letter was not returned to us." Howard Ayres, secretary of the trading company, testified that plaintiff did not receive the letter of September 2d. He further testified: "Our purchase of August 18, 1899, was made upon the conditions stated in our letter of July 11, 1899, and the condition as to the engagement of steamer space was also referred to in our telegram of August 18, 1899, and in the letter of same date." No inquiry was made by the China & Japan Trading Company about the 500 bales of cotton in question from August 28th to November 13th, although in the meantime several communications passed between them as to other shipments. On November 13th the trading company wrote Davis & Co. as follows: "We are constrained to ask you when you are likely to ship the 500 bales of middling sold us August 18th for October-November delivery?" Davis replied on November 20th, and referred them to his letter of September 2d, in which he had canceled the contract. The trading company replied that they had not received the letter of September 2d, and would not have considered the contract canceled if they had received it; stating: "It took two to make the contract, and it will take two to cancel it. We trust you will make prompt shipment of this 500 bales middling due us under our contract of August 18th, and doubtless you will be able to secure freight room. Indeed, we are continually receiving offers of freight room by all the Pacific routes, as well as by way of Suez, and there seems to be no difficulty in making shipment." When Davis had asked them to assist him in getting shipping space on August 19th, they replied on August 22d that they could not help him.

John W. Thompson and M. L. Morris, for plaintiff in error.
F. H. Prendergast, for defendants in error.

Before PARDEE and SHELBY, Circuit Judges, and BOARMAN, District Judge.

PER CURIAM. While in the letters of July 11th the trading company gave notice that engagements of freight room covering through shipment and transshipment to destination should be simultaneous with sale to the trading company, yet in the offer by the telegram of Davis & Co. of August 18th no engaged freight room was either promised or suggested. It may be that, as the offer was optional as to destination, China or Japan, and as to October-November or November-December shipment, it was impracticable to promise or guaranty freight room in advance of the trading company's absolute acceptance. The trading company's telegram of August 18th and its letter of the same date make the acceptance of Davis & Co.'s offer conditional upon Davis & Co. having secured fixed freight engagement and steamer space to Japan, and in the letter reasons are given why the acceptance was thus made conditional upon the secured freight space. The case shows that the trading company did not waive, but always insisted upon, this condition, and in its letter of August 28th it deals with the matter in this language:

"We are not pleased with your carelessness in the matter of freight on this lot of cotton. You had our letter of general instructions before you, in which it was specifically stated that the freight engagement must be made at the time of selling us the cotton. With this warning and the experiences of last year fresh in mind, we are at a loss to see why you should have run this risk."

This letter, in connection with the letter claimed by plaintiff to be an acceptance, is absolutely inconsistent with the proposition now necessary to maintain plaintiff's case, to wit, that Davis & Co.'s offer of August 18th was unconditionally accepted. If that offer was unconditionally accepted, why the specific reservation in the letter of August 18th, and why, as late as August 28th, write about the carelessness and risk of Davis & Co. because they had not previously engaged freight space to Japan? We see no reason to doubt that Davis & Co. by letter of September 2d, canceled the offer. Even if the trading company never received the letter canceling the offer, its silence as to delivery, under the alleged contract of August 18th, from August 28th to November 13th following, while cotton was steadily advancing, is very significant.

The trial judge concluded that the contract was never accepted so as to be binding upon both parties, and properly instructed a verdict for the defendant, and the judgment upon that verdict is affirmed.

AMERICAN SUGAR REFINING CO. v. CITY OF NEW ORLEANS.

(Circuit Court of Appeals, Fifth Circuit. December 9, 1902.)

No. 920.

1. FEDERAL COURTS—FOLLOWING STATE DECISIONS—CONSTRUCTION OF STATE CONSTITUTION.

Where the decision of a cause depends upon the construction placed upon a provision of a state constitution, the federal courts follow the decisions of the highest court of the state thereon, and an appellate court will reverse a judgment below based on such decisions, where, pending the appeal, they have been overruled, when no question of contract rights is involved.

In Error to the Circuit Court of the United States for the Eastern District of Louisiana.

Charles Carroll and J. W. Carroll, for plaintiff in error.

Saml. L. Gilmore, C. H. La Villebeuvre, and H. G. Dupre, for defendant in error.

Before PARDEE, McCORMICK, and SHELBY, Circuit Judges.

PER CURIAM. When this case was before the circuit court, the learned trial judge followed *State v. American Sugar Refining Co.*, 51 La. Ann. 562, 25 South. 447, where it was held by the supreme court of the state of Louisiana that the plaintiff in error, the American Sugar Refining Company, was not a manufacturer, within the meaning of article 206 of the constitution of the state of Louisiana (1879), exempting manufacturers under certain circumstances from license taxation. Since this writ of error has been pending another case between the same parties has been brought before the supreme court of the state, and a decision rendered explicitly reversing the former case, and holding that the American Sugar Refining Company is a manufacturer of sugar, within the meaning of the constitution, and as such exempt from all licenses levied by the city or state. As the supreme court of the state has changed its ruling on the meaning of the article of the state constitution controlling the issues in the present case, we are bound to follow, even if we do not fully agree as to the correctness of the decision made. As, however, we do fully concur, we hasten to reverse the judgment of the lower court in this case, and remand the cause, with instructions to dismiss the same, at plaintiff's costs. And it is so ordered.

¶ 1. State laws as rules of decision in federal courts, see notes to *Griffin v. Overman Wheel Co.*, 9 C. C. A. 548; *Wilson v. Perrin*, 11 C. C. A. 71; *Hill v. Hite*, 29 C. C. A. 553.

See Courts, vol. 13, Cent. Dig. § 956.

**GOODYEAR SHOE MACHINERY CO. OF PORTLAND, ME., v.
DANCEL et al.**

(Circuit Court of Appeals, Second Circuit. December 15, 1902.)

No. 26.

1. PATENTS—CONTRACT OF ASSIGNMENT—AGREEMENT TO PAY ANNUITY TO ASSIGNOR.

Under a contract by which the assignee of a patent agreed to pay to the assignor in each year while such patent "remains in force as a valid patent the sum of \$5,000 as an annuity," the right to such payments does not cease on the death of the assignor, because they are termed an "annuity," but payment may be enforced by his legal representatives so long as the patent remains in force.

2. CONTRACTS—PARTIES—ACTION AT LAW AGAINST ASSIGNEE.

An agreement by the assignee of a contract, by which he assumes the obligations of his assignor thereunder, does not make him a party to the contract, so that he may be sued thereon at law by the other party; nor can such an action be maintained upon the doctrine of subrogation, which pertains to equity only.

3. STIPULATIONS—MATTERS CONCLUDED.

A stipulation by the defendant in an action at law to waive a jury and go to trial before the court is not a waiver of his right to insist that plaintiff has no right of action at law.

4. FEDERAL COURTS—DISTINCTION BETWEEN LAW AND EQUITY—EFFECT OF STATE LAWS.

Neither the statutes nor decisions of the courts of a state can confer authority on a federal court sitting therein to exercise equitable jurisdiction in actions at law.

In Error to the Circuit Court of the United States for the Southern District of New York.

See 106 Fed. 551, and 109 Fed. 333.

Edwards H. Childs, for plaintiff in error.

Roger Foster, for defendant in error.

Before WALLACE, TOWNSEND, and COXE, Circuit Judges.

WALLACE, Circuit Judge. The plaintiff in error was the defendant in the court below, and brings this writ of error to review a judgment for the plaintiffs. The action was tried in the court below without a jury, a jury having been waived by the parties; and upon the motion of the plaintiffs the trial judge ordered a judgment in their favor upon the pleadings. The action was brought by the administrators of Christian Dancel to recover the unpaid installments alleged to be due upon a written contract between Dancel and the Goodyear Shoe Machine Company executed January 2, 1892.

The assignments of error present the question whether by the terms of the contract the installments were payable only during the life of Dancel. He died in October, 1898, and the unpaid installments accrued subsequently to that date.

As judgment was ordered upon the pleadings, all the averments of the answer, except such as state legal conclusions, are to be taken as true. The defendant by its answer alleged that the contract was a Massachusetts contract, and that by the law of that state the undertaking was a promise to pay during Dancel's life only. This court takes

judicial notice of the law of Massachusetts, both statutory and unwritten, and is not concluded by the averments of the answer in respect thereto. *Chicago & A. R. Co. v. Wiggins Ferry Co.*, 119 U. S. 615, 7 Sup. Ct. 398, 30 L. Ed. 519. Whether the installments were payable only during the life of the promisee is a question depending upon the true meaning of the contract, and there is no statute of Massachusetts affecting the question, and there are no controlling adjudications of the courts of that state determining the legal construction of such a contract as the present.

The contract, after reciting that the Goodyear Company had previously become the owner of certain letters patent of the United States issued to Dancel, and of an application made by Dancel for another patent, and that Dancel had by an assignment of even date with the contract transferred to the Goodyear Company letters patent of the United States dated September 8, 1891, and numbered 459,036, granted him for an improvement in sewing machines, contained the following covenant:

"(1) That the Goodyear Company, in consideration of said assignment and of the agreements of said Dancel herein contained, doth agree to pay the said Dancel in each year while the United States letters patent No. 459,036 remain in force as a valid patent, the sum of \$5,000 as an annuity, such annuity to be payable monthly in installments of \$416% each."

There would be no doubt of the meaning of the contract if the words "as an annuity" had been omitted in the covenant. It would have been a promise to pay a stated annual sum during the term of the patent, or as long as the patent should be enforceable as a valid grant, and would have inured to the benefit of the administrators throughout that period; but these words import uncertainty into it.

An annuity is defined as "a stated sum, payable annually" (*Pearson v. Chace*, 10 R. I. 455), or as "a yearly payment of a certain sum of money, granted to another in fee, for life, or for years" (*Kearney v. Cruikshank*, 117 N. Y. 95, 22 N. E. 580; *Bartlett v. Slater*, 53 Conn. 102, 22 Atl. 678, 55 Am. Rep. 73). It has usually been judicially defined in construing testamentary dispositions, marriage settlements, deeds of separation, and promises of a nature to imply the notion of personal enjoyment on the part of the promisee. In *Blewitt v. Roberts*, 1 Craig. & P. 274, Lord Chancellor Cottenham said:

"An annuity may be perpetual, or for life, or for a period of years; but, in the ordinary acceptation of the term used, if it should be said that a testator had left another an annuity of £100 per annum, no doubt would occur of the gift being for the life of the donee."

The authorities are collated and their result stated in 2 Am. & Eng. Enc. Law (2d Ed.) 393, as follows:

"The duration of an annuity depends, as a general rule, upon the construction of the instrument by which it is created. Where there is nothing to be found beyond a simple gift of an annuity, and there is no explanatory language as to its duration, the annuitant takes for life only."

The Massachusetts decisions cited by the plaintiff in error are to the same effect. On the other hand, it is abundantly settled by the authorities that a bequest or grant of an annual sum, with words of limitation, such as for a definite term or for the life of another person, does not lapse with the life of the annuitant, but survives to his per-

sonal representatives; and the words of limitation fix its duration. This was decided by Lord Chancellor Hardwicke in the early case of *Savery v. Dyer*, 1 Amb. 139, and is said in *Montanye v. Montanye*, 29 App. Div. 377, 51 N. Y. Supp. 538, never to have been questioned since. It is only when there is no explanatory language as to its duration that an annuity is limited to the life of the annuitant.

The plaintiff in error insists that the covenant should be read as if the words "as an annuity" were the only words signifying the duration of the monthly payments, or as if they qualified the promise to pay during the life of the patent and limited the duration of the payments to the life of Dancel. If it had been the intention of the parties that the payments should cease with the life of Dancel, that intention could have been easily expressed in a manner to make it perfectly clear by inserting, after the words "doth agree to pay to said Dancel each year," the words "during his life." We think such was not the intention of the parties.

Looking at the subject-matter of the contract, we find it to be one that concerns the sale and purchase of a patent, the term of which had 16 years to run from the previous September, but which might at some earlier date cease to be valid. The value of the patent depended measurably, perhaps mainly, upon the duration of the monopoly created by it. It could be estimated upon the basis of its yearly value, or out and out and irrespective of that basis; but its value was not in the least dependent upon the life of the patentee. In fixing the purchase price, it is fair to assume that the parties intended to fix a price which they regarded as a fair equivalent for the value of the patent. It is obvious that they did not intend to fix the price upon the basis of an out and out value; and it would seem that their dominant thought was to adopt the other standard of value,—its yearly value for the period of its duration,—and that they estimated this at \$5,000 a year.

If the clause had read, "The Goodyear Company doth agree to pay to said Dancel an annuity of \$5,000 in each year while the patent remains in force," there would be no fair room to doubt that the annuity would have been payable so long as the patent remained in force. We think it should be so read. The term "as an annuity" meant "annuity" merely, and not "but only as an annuity." It was doubtless unnecessary to use it; but tautology is so frequent in private, as well as public, documents, and in statutes, that undue emphasis ought not to be placed upon the use of redundant words and phrases.

The assignments of error also present the question whether the promise can be enforced against the present defendant. The complaint alleges that the defendant (a Maine corporation) purchased the letters patent from the Goodyear Company (a Connecticut corporation), and in an instrument of assignment to it, and in consideration thereof, agreed to assume all the obligations of the Goodyear Company to pay the annuity provided for in the contract between the latter and Dancel. This averment is admitted by the answer. The effect of this agreement was to create the relation of principal and surety between the defendant and the Connecticut corporation, and as between those parties the defendant became primarily liable for the obli-

gations arising from the contract of the Goodyear Company with Dancel; and upon the equitable doctrine that a creditor shall have the benefit by subrogation of any obligation or security given by the principal to the surety for the satisfaction of the debt, the plaintiffs, if this action had been brought in equity, would have been entitled to enforce the covenant of the defendant. According to the decisions in *Second Nat. Bank of St. Louis v. Grand Lodge of Free & Accepted Masons of Missouri*, 98 U. S. 123, 25 L. Ed. 75, *Cragin v. Lovell*, 109 U. S. 194, 3 Sup. Ct. 132, 27 L. Ed. 903, and *Keller v. Ashford*, 133 U. S. 610, 10 Sup. Ct. 494, 33 L. Ed. 667, the plaintiffs could not maintain an action at law against the defendant upon the covenant. The latter case was a bill in equity by a mortgagee against the grantee of the land subject to the mortgage, which mortgage the grantee had agreed to pay. It was held after full examination of the authorities that the mortgagor could not sue at law. It was also held that in equity, as at law, the contract of the purchaser to pay the mortgage, being made with the mortgagor and for his benefit only, created no direct obligation of the purchaser to the mortgagee; but it was also held that, upon the doctrine that the mortgagee was entitled as a creditor to the benefit of any obligation or security given by the purchaser to the mortgagor for the payment of the debt, he could enforce the agreement to pay the mortgage in a court of equity. The cases of *Willard v. Wood*, 135 U. S. 309, 10 Sup. Ct. 831, 34 L. Ed. 210, and *Insurance Co. v. Hanford*, 143 U. S. 187, 12 Sup. Ct. 437, 36 L. Ed. 118, are to the same effect.

The circumstance that the defendant consented to go to trial before the court as a court of law was not a waiver of his right to insist that the plaintiffs had no right of action at law. In *Willard v. Wood*, supra, the action was at law, and was tried in the court below upon an agreed statement of facts, with a stipulation that the plaintiff should have judgment for a specified sum if upon the agreed statement the court held that he was entitled to recover. The court, after pointing out that in the court below, as in the circuit courts of the United States, the jurisdiction in equity is distinct from the jurisdiction at law, and that equitable relief could not be granted in an action at law, said:

"A statement of facts agreed to by the parties, or, technically speaking, a case stated, in an action at law, doubtless waives all the questions of pleading or form of action which might have been cured by amendment; but it cannot enable a court of law to assume the jurisdiction of a court of equity."

It is hardly necessary to state that the law of the remedy is not to be determined by the decisions of the courts of the state in which the action was brought, and that neither the decisions of its courts nor the statutes of New York can confer authority upon the federal courts sitting within that state to exercise equitable jurisdiction in actions at law. State legislatures cannot abolish in the federal courts the distinctions in actions at law and in equity by abolishing such distinctions in their own courts. *Swayze v. Burke*, 12 Pet. 11, 9 L. Ed. 980; *Bennett v. Butterworth*, 11 How. 669, 13 L. Ed. 859; *Jones v. McMasters*, 20 How. 8-22, 15 L. Ed. 805; *Fenn v. Holme*, 21 How. 481, 16 L. Ed. 198; *Thompson v. Railroad Co.*, 6 Wall. 134, 18 L. Ed.

765; *Railroad Co. v. Paine*, 119 U. S. 561, 7 Sup. Ct. 323, 30 L. Ed. 513.

We conclude that the plaintiffs were not entitled to recover, because they could not sue at law upon the promise made by the Maine corporation to the Connecticut corporation. The judgment must therefore be reversed, and it is

So ordered.

GLOBE-WERNICKE CO. v. FRED MACEY CO.

(Circuit Court of Appeals, Sixth Circuit. November 5, 1902.)

No. 1,039.

1. PATENTS—INVENTION—SECTIONAL BOOK CASES.

The Wernicke patent, No. 557,737, for improvements in sectional bookcases, construed, as to claims 12, 15, 16, 17, 18, 19, and 20, and held to exhibit no more than a judicious selection of well-known devices, obvious in their uses, and the application of the same to the construction of bookcases, and therefore void for lack of invention.

2. EQUITY PLEADING—AMENDMENT OF BILL.

Where a bill presents a case in a double aspect, by charging that certain acts of defendant constitute an infringement of a patent and also unfair competition, praying relief on both grounds, an order sustaining a demurrer addressed to the bill in one aspect is merely interlocutory, and remains subject to revision by the court until final decree, and the court may at any time permit an amendment relating to that feature of the bill.

3. UNFAIR COMPETITION—RIGHT TO PROTECTION.

A claim of unfair competition cannot be sustained on allegations that complainant has built up a large business in the manufacture and sale of sectional bookcases having certain general characteristics, such as variety in size, style, finish, and kind of wood, and so made that additional sections can be added from time to time, and that defendant is making and selling sectional bookcases in imitation not only of the system, but of such general features, with intent to deceive the public into the belief that they are complainant's goods. It being open to the public to make and use bookcases having such characteristics, it is equally open to any one to make them for sale and to put them on the market.

Appeal from the Circuit Court of the United States for the Western District of Michigan.

This is a controversy between rival manufacturers of sectional bookcases. The bill, which was filed by the appellant, presents a case having a twofold aspect, complaining that the appellee is manufacturing and selling sectional bookcases which infringe patent No. 557,737, granted to Wernicke, April 7, 1896, which the appellant owns by assignment; and complaining also that the appellee is guilty of unfair competition in its business by manufacturing and selling sectional bookcases purposely made to resemble those which are being made and sold by the appellant under its said patent, to such an extent that they may be, and are, mistaken by the trade for those of the appellant and purchased as such. So much of the matter of the bill as relates to the infringement of the patent was heard and decided upon pleadings and proofs. That part which complains of unfair competition was heard and decided upon the bill and a demurrer reaching to the merits. The bill was dismissed in respect to both grounds for relief.

¶ 1. Unfair competition, see notes to *Scheuer v. Muller*, 20 C. C. A. 165; *Larc v. Harper & Bros.*, 30 C. C. A. 376.

A. C. Denison and Robert H. Parkinson, for appellant.
Fred L. Chappell, for appellee.

Before LURTON, DAY, and SEVERENS, Circuit Judges.

SEVERENS, Circuit Judge, having given the foregoing outline of the case, delivered the opinion of the court.

The patent No. 557,737, upon which the appellant relies, was granted to Wernicke for certain new and useful "improvements in sectional bookcases." The inventor states in his application that his invention relates to sectional bookcases of such construction that each section may be "collapsed" and shipped in a knock-down condition, and afterwards readily assembled by the person receiving the same, and also to a particular construction of the door, back, and other parts of the section, and the combination of the parts thereof, as described and claimed.

The general plan of his bookcases consists in building cases for each row of books intended to be accommodated, separately, in the form of a long box opening at the front by a glass door hinged by a hook under the top of the case on a pin projecting in from the body of the case at each end, and normally hanging down and closing the case, but adapted to be turned outward and upward from the bottom and pushed back over the pivots through grooves on the inside of the case, to accommodate the removal and replacing of the books standing in the case. These doors have a strip of felt fastened to the inner edge of the top rail to close the opening and keep out the dust and air. The cases are of equal length and otherwise of such conformity that they may be piled one above the other, and the tiers placed end to end, and having interlocking dovetailed attachments at their ends, and having also two strips lengthwise on the bottom, and a corresponding single strip lengthwise of the top, adapted to fit between the two bottom strips of the next section above, by which they are secured together and made to present an even front. They could be piled as high or extended lengthwise to such extent as is desired. Metallic strips are fastened around the ends and front corners of the case at the bottom, extending downward so as to shut down outside of the top of the case below, on which strips the interlocking attachments above mentioned are fastened. Suitable bases and caps are provided, but they constitute no part of the invention.

Following the specification, 20 claims are appended, of which Nos. 12, 15, 16, 17, 18, 19, and 20 are alleged to be infringed. They are as follows:

"Claim 12. A bookcase comprising a series of separable sections placed one above the other, the ends of the longitudinally adjoining sections being provided with the strips, 24, having the ends, 25, and the alternate strips being provided with a dovetailed tenon, 26, to engage a similar shaped slot in the strip provided in the end of the abutting section, substantially as described."

"Claim 15. A bookcase comprising a series of sections, the ends of said sections being provided with the grooves, 42, and the shoulders, 40, the door arranged to slide upon the shoulders formed by said grooves, the pins, 44, the hooks, 43, for engaging the same, and said door being provided on its inner edge with the felt, 39, for the purpose set forth.

"Claim 16. A bookcase comprising a series of separable sections adapted to

be placed one above the other, the ends and top and bottom of each section being provided with interlocking devices adapted to engage corresponding devices in the ends, bottom, and top of the adjacent sections.

"Claim 17. A bookcase section having its bottom formed of the longitudinal strips, 2 and 3, and the plate, 4, arranged over said strips, in combination with a similar section having at its top a longitudinal strip, 8, adapted to fit into the space between said strips, 2 and 3, and below said plate, 4.

"Claim 18. A bookcase section having its bottom provided with the two strips, 2 and 3, and provided with finishing strips, 24, extending across the ends of the strips, 2 and 3.

"Claim 19. A bookcase section having its bottom provided with the two strips, 2 and 3, having a space between them to receive the top strip of a similar section, and the finishing strips, 24, extending across the ends of said strips, 2 and 3, and provided with means for interlocking with similar strips upon the ends of abutting sections.

"Claim 20. A bookcase section provided at the lower part of each end with a finishing strip extending from the front to the rear of the section, and having a projection or recess adapted to interlock with a corresponding recess or projection upon the end of an abutting section."

The following diagrams selected from the drawings sufficiently illustrate these claims:

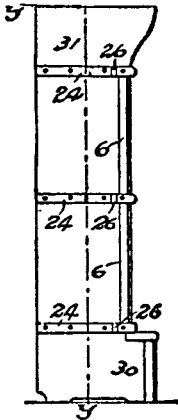

Fig. 2.

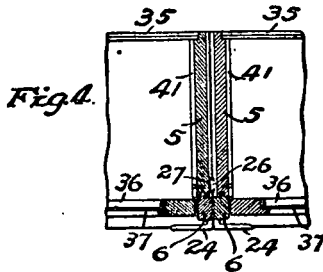

Fig. 4.

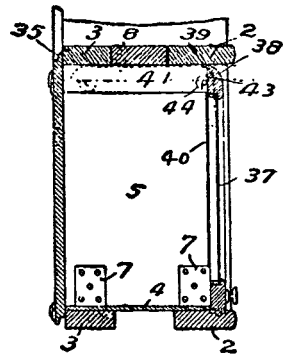

Fig. 10

The validity of these claims is denied upon the ground that they were anticipated, or, if not fully anticipated, they represent only the result of mere mechanical skill over similar constructions for various uses. Before taking up these claims separately, it will be convenient to ascertain what had already been done in that direction. Wernicke knew that previous constructions of sectional bookcases had been made, and that he did not suppose he was a pioneer; for he states, as we have seen, that his invention was of improvements in the construction of such cases, and he had himself, jointly with another, taken out a patent on such cases. Not all of the previous sectional cases were made for the purpose of housing books; but as they had been patented, and were adapted to be used for that purpose without material alteration, it will not, we presume, be contended that applying them, even with slight modifications, to this new use would constitute patentable invention. Doubtless the re-

sult would be otherwise if the changes necessary to adapt them to the new use were not obvious and required more than mere skill to devise them.

Before going into particulars, it will be convenient to take a more extensive survey of the condition of the art in the construction of these and similar manufactures. A patent (No. 220,163) for improvement in sectional bookcases was issued to W. J. Marble, September 30, 1879, and shows sectional cases of the same general form as those of Wernicke, and having the same strips lengthwise of the bottom and top. They were intended to be put on top of one another, and to have a door adapted to be readily removed, or a curtain rolling up in front, as might be preferred. It did not have the separate door for each section, as in the Wernicke patent, nor did it suggest continuation of the bookcase by adding other tiers at the end. But a still earlier patent (No. 181,447), to Keys and Taylor, in 1876, showed a combination of a writing desk and a bookcase in sections one above the other, each inclosure having a door in front adapted to swing open and then slide in over the section so as to leave the front open and the door out of the way. The attachments by which this movement of the door was effected are not shown, but seem to have been left to the ingenuity or skill of the builder. On March 7, 1893, a patent was granted to Watts (No. 492,909) for an invention the substance of which was a front door for a refrigerator, and so constructed as to open on hinges above, and then slide back over the provision chamber. The hinges were made in precisely the same way as those in the Wernicke patent; that is to say, they consisted of a hook on the door turning over a pin projecting in from the frame. Moreover, the door, when thus pulled open and raised to a horizontal position, was pushed in, sliding on "guide-cleats." A patent to Berners in 1890 was for the invention of a door or analogous device, in which the door was lifted up and then pushed backward on pins or rollers projecting at the edges of the door, and sliding in grooves inside the case. A patent to Kroenke (1886) shows a refrigerator door adjusted so as to swing forward from the bottom, and be raised to a horizontal or nearly horizontal position, and then pushed back on guide grooves in the edges, moving on pins projecting inwardly from the casing. In the same year a patent was issued to Lee for a showcase having a glass door in front sliding outward and upward, and then pushed back upon pins projecting from the edges, sliding in "seats" (grooves) on the inner side of the frame. Another patent to Wernicke and Burr for sectional bookcases will be mentioned further on.

From these and other structures illustrated by patents shown in the record, we are satisfied that it was a well-known method of attaching and using a door for similar structures to hinge it at the top by a pin or other form of pivot over which the door was raised and pushed back, sometimes in guides on the inside of the case, or sometimes with the pin or grooves on the opposite members. It further appears that such devices had been employed in this particular art, and, as we have seen in one form of patented structure, the very form of hinge and groove employed by Wernicke was shown.

Sectional bookcases put up one on top of the other, and constructed in the same manner at the top and bottom as those in the Wernicke patent, to hold them in vertical alignment, had been made and patented many years before. We reserve the discussion of minor features for consideration in dealing with the particular claims in controversy.

Claim 12 contemplates a bookcase made up of sections placed in tiers one above the other and of tiers of sections placed end to end; metallic ends coming around the front corners; a dovetailed tenon on each alternate strip to engage with a corresponding slot on the end strip of the adjacent section. Of course, there is nothing in placing the sections one above the other, or the tiers of sections end to end, which is a mere duplication, and, indeed, was not new. The substance of the claim, therefore, consists in the employment of the metallic strip and the dovetailed joint. The principal purposes of the strip are to cover the division or joint between two sections, and thereby improve the appearance, also to aid in holding the sections in alignment. In the Wernicke & Burr application of 1894 a like strip called a "suitable ornamental molding" is provided to conceal the ends of the slats on the bottom of the crates. It is not stated of what material the molding should be made. It might be either of wood or metal, and in either case it would serve the same purpose of effecting an alignment of the sections as that mentioned in this claim of the Wernicke patent. There was nothing amounting to invention in extending this strip around the front corner for the same purpose. This strip is in legal contemplation the same thing as that on the Wernicke & Burr bookcase. Other similar devices for the same purpose are shown in the evidence of the prior art. The dovetailed tenon attachment for locking the ends together had also been previously used for the same or kindred purposes, and was found in previous patents. In 1886 N. H. Pohl obtained a patent for locking bookcases together by this method. In a patent to Spruce, issued in 1880, this form of construction was used to attach the ends of postoffice boxes together. The whole subject of that patent was the attaching together in a mass several boxes by a dovetailed fastening. It is needless to pursue this matter by referring to other similar forms shown by the record, because the appellee does not use that mode of connection. Its method consists of using projections on the ends of the sections and perpendicular thereto, in contact so as to keep the faces of the tiers of sections in alignment. They do not hold the ends of the sections together laterally. And it is clear enough that these projections are not only unlike the dovetailed tenon and its mate, but they do not effect the same results.

Claim 15 is as follows:

"A bookcase comprising a series of sections, the end of said sections being provided with the grooves, 42, and the shoulders, 40, the door arranged to slide upon the shoulders formed by said grooves, the pins, 44, the hooks, 43, for engaging the same, and said door being provided on its inner edge with the felt, 39, for the purpose set forth."

40 is the shoulder against which the frame of the door rests. It is simply a stop for the door, and is common in the ordinary construction of door and window frames. The hook and pin was an old form of constructing an open joint, and was used as we have shown in the Watts patent. The duplication of the sections by imposing one upon the other and setting the tiers end to end was not new, supposing it to have ever been patentable as an invention. The attachment of the felt strip on the inner edge of the door is all that remains of this claim for consideration.

Felt strips on the edges of windows and doors to keep out air are old, as every one knows. But complainant and its experts think that the strip makes the door tighter, and that this produces the effect of a bellows to blow the dust out when the door is opened and shut. Possibly it has such an effect. If it does, it is the same effect and is of the same advantage as the same attachment on any other door. But the patentee attaches this strip to the inside of the upper edge of the door, and this is the call of the claim. He has thus restricted himself to that construction. The appellee uses a felt strip, but attaches it to the outer edge of the door. Seeing that similar uses of such strips attached in similar ways were old and common, and having regard also to the specific character of the claim, we think there is no infringement, even if this added feature made the claim patentable.

Claim 16 reads as follows:

"A bookcase comprising a series of separable sections adapted to be placed one above the other, the ends, top, and bottom of each section being provided with interlocking devices adapted to engage corresponding devices in the ends, bottom, and top of the adjacent sections."

This is a combination of features which we have already discussed, and we see no occasion to consider it further. All the elements were old, even in bookcases.

Claim 17 is this:

"A bookcase section, having its bottom formed of the longitudinal strips, 2 and 3, and the plate, 4, arranged over said strips, in combination with a similar section having at its top a longitudinal strip, 8, adapted to fit into the space between said strips, 2 and 3, and below said plate, 4."

It adds to the elementary form of the section a plate (or veneer) to the bottom on the inside. It is secured to the bottom slats and becomes integral with them. It comes to the same thing as if the opening below had been made more shallow, not extending through the bottom, and the top slat in the section below thinner, which would be but a slight variation only from the earlier forms. The object of this plate was doubtless to prevent the abrasion of the lower edges of the books when they were being put into or removed from the case. If there was a need of this, as we can well suppose if the slat from below extended through the bottom, can it be regarded as invention to put this veneering in to make a smooth bottom? It seems to us so obvious a remedy that it need not long delay an ordinary workman to devise it, and that it would be absurd to elevate the adoption of such a common expedient to the dignity of invention.

Claim 18 is as follows:

"A bookcase section having its bottom provided with the two strips, 2 and 3, and provided with finishing strips, 24, extending across the ends of the strips, 2 and 3."

This counts in the two bottom slats and the finishing strip. As we have already seen, a finishing strip adapted to the same purposes was shown in the Wernicke & Burr patent for a "separable bookcase." The choosing of a particular kind of strip and the substitution of metal for wood are only matters of taste or of ordinary judgment.

Claim 19 is as follows:

"A bookcase section having its bottom provided with the strips, 2 and 3, having a space between them to receive the top strip of a similar section, and the finishing strips, 24, extending across the ends of said strips, 2 and 3, and provided with means for interlocking with similar strips upon the ends of abutting section."

The only peculiar feature in this claim is the location of the interlocking devices upon the finishing strips. It is suggested that this, although it does not increase the effectiveness of the interlocking beyond what would be done by locating the interlocking device upon some part of the end of the case itself, yet it avoids the marring of the ends and is neater. If this is an advantage, it was very obvious how it could be attained. But it is clear from Wernicke's specification that what he intends by "means for interlocking" is the dovetailed tenon and its counterpart, for he nowhere suggests any other mode of lateral connection of his sections. The appellee does not, however, use that device, as has already been stated, and, as it is made an essential element in the claim we are discussing, there is no infringement if the claim were to be held valid.

Claim 20 is this:

"A bookcase section provided at the lower part of each end with a finishing strip extending from the front to the rear of the section, and having a projection or recess adapted to interlock with a corresponding recess or projection upon the end of an abutting section."

This claim excludes everything else but the finishing strips and the interlocking projections thereon. What we have already said with reference to claim 19 is applicable to claim 20. It is obvious that the interlocking means intended must be such as shall prevent the sections in the tiers from spreading apart laterally, and whatever the merits of the claim may be we think the appellee does not infringe it.

And finally, after a full and careful consideration of the patent upon which the appellant relies, we feel constrained to the conclusion that it exhibits nothing more than a judicious selection of well-known devices, obvious to their purposes, and putting them into the construction of bookcases, and that there was nothing of the quality of invention in any part thereof. Given the idea of sectional bookcases, the imposition of one upon another, and the lateral extension thereof by duplication of the tiers, all the expedients employed in carrying out that idea are borrowed and not invented. And the things borrowed were close at hand and had already been disclosed.

The fact (for we believe it to be the fact) that these bookcases

have gone into extensive use is due, as we think, to the elegant workmanship employed in their manufacture, and the convenience of having the sections separable, aided by the energy with which, as the bill states, they were pressed upon the market.

In the other aspect of the bill, the relief was prayed for the unfair competition in business therein alleged. It appears that a demurrer to that portion of the bill was sustained. Later on, and after six months had elapsed, an amendment of the bill in that regard was allowed against the objection of the appellee. The bill as thus amended was demurred to, and the demurrer was sustained upon the final hearing of the case, when the bill was dismissed. It is pressed upon us by the appellee that as no action had been taken after the first order of dismissal, and the six months allowed by law for an appeal had expired, it was beyond the power of the court to allow an appeal. But this contention is founded upon a misapprehension in respect to the finality of the first order. The bill was not founded upon two separate matters or transactions. The conduct of the appellee complained of consisted of the same acts. The legal qualities of those acts were in some respects different, and the result was that the facts presented a double aspect. It is upon this consideration that such a bill can be sustained against an objection that it is multifarious. Upon such a bill as this, successive final decrees are not pronounced. Interlocutory orders may be entered, which have the effect of disposing of some of the matters of the bill for the time being, and the case proceeds until all the matters are decided, whereupon a final decree is entered. Meantime the court does not lose control of the questions decided in the preliminary or interlocutory orders, but may revise them, if it finds sufficient reason, in rendering the final decree. We have no doubt that the allowance of the amendment was within the power of the court and subject to its discretion. Moreover, we see no reason to think its discretion was wrongfully exercised.

Upon the merits of this aspect of the case, we are of opinion that the decree of the circuit court was right. The foundation of this claim of the appellant is that upon the footing of the Wernicke patent it and its predecessors in the business have built up a large business in the manufacture and sale of bookcases intended to conform to the system of such patent; that they have made them in sectional crates in such mode that the bookcases which they compose may be built of any height or any length, or be put in any desired form of arrangement; that their sections, or "units," as they are termed, are made of "different sizes, so that large or small could be had as desired"; that they were built of a variety of woods, of different styles and finish, so that the purchaser could choose, within limits which are not stated, any style, material, or finish he might desire. And it is alleged that at great expense they built up a large trade in such bookcases, not only in originally supplying them, but in selling additions made in the different sizes, styles, materials, and finish of the originals, so that they would harmoniously fit into the original structures. There is considerable amplification, but that is the substance. The complaint is that the appellee is making and selling sectional bookcases in imitation, not only of the "system" which the appellant employs, but also

of the sizes, styles, material, and finish of those of the appellant, and this imitation is done with the intent to deceive the public and induce purchasers to buy their goods of the appellee. It is not alleged that the defendant represents to the public that its bookcases are of the complainant's manufacture, but only that it makes bookcases and sections in the same sizes, styles, varieties of wood, and finish as the complainant's, and that by reason thereof the public are misled. The intention is not material, if the defendant has the right to do that which is complained of. On the other hand, if the thing done is wrongful, the lack of intention would not excuse. In either case, the motive is immaterial to any question involved in the present inquiry. 2 Greenl. Ev. § 270; *Chatfield v. Wilson*, 28 Vt. 49; *Heath v. Unwin*, 15 Sim. 552 (per Vice Chancellor Shadwell); *Stead v. Anderson*, 4 C. B. 806; *Parker v. Hulme*, 1 Fish. Pat. Cas. 44, Fed. Cas. No. 10,740. It is impossible to admit the claim of the appellant to the extent of its pretensions, which would amount to a monopoly of such proportions as would practically engross the business. Without doubt, a party may adopt distinguishing marks to denote the origin of production as being his own, or he may adopt some other peculiar method of distinguishing his own goods, and thus retain the benefit of the good reputation which he has acquired for them. But the very idea of distinguishing them implies that it cannot be done by such universal characteristics as belong to other goods of the kind, and which the general public have the undoubted right to use. Thus, the public have the right to make bookcases of any size. From the nature of the requirements they must have resemblance in form, dimensions, and appearance. So no one can have the exclusive privilege of locating them in sections one above another or end to end, nor in making them of any kind of wood or metal as he chooses, nor in the style or in the finish of his work, unless it is peculiar and out of the ordinary. Upon the claim made for the appellant, it would be impossible, without invading complainant's right, to construct and sell a bookcase having the most desirable characteristics. Nor is it competent for one person to appropriate to his own purposes any common and general characteristics of the goods he manufactures to such an extent that another shall be impleaded or embarrassed in his free right to use such characteristics in his own business. In the present case, the complainant does not rest upon the adoption of special characteristics of any kind, but upon the use of the common features which pertain to the article made and sold.

A grievance of which much complaint is made is that, in consequence of the resemblance of the defendant's sections to the complainant's, the public are led to buy the defendant's sections for the purpose of extending the bookcases they have already purchased of the complainant's manufacture. But, unless the complainant has in some way obtained a monopoly of building bookcases in this way, it can have no valid objection to the defendant supplying such additions to bookcases already sold by the complainant.

The decree of the circuit court is affirmed.

CONSOLIDATED RUBBER TIRE CO. et al. v. FINLEY RUBBER TIRE CO. et al.

(Circuit Court, N. D. Georgia. October 10, 1902.)

No. 1,101.

1. PATENTS—INFRINGEMENT—TRIAL—SUPPLEMENTAL PLEADINGS—RES JUDICATA.

Where, in a suit for infringement of a patent, against the seller of the patented articles, the manufacturer was permitted to intervene for the purpose of defending the action on the ground that defendant had ceased to sell its manufactured goods, and the bond given by him to prevent a preliminary injunction had probably become ineffective, and a decision was rendered holding that the original defendant was estopped to question the validity of the patent as against the plaintiff, the estoppel operating between defendant and the complainant controls the litigation, so that the manufacturer would not be entitled to file a supplemental answer setting up a decision of the circuit court of appeals holding the patent void as *res judicata*.

In Equity. Application to file supplemental answer.

Staley & Bowman, Hoke Smith, and H. C. Peebles, for complainants.

H. A. Toulmin and Edmund Wetmore, for defendants.

NEWMAN, District Judge. The conclusions reached by the court in this case are fully set out in an opinion filed on June 2, 1902 (116 Fed. 629). Since that time an application has been made for leave to file a supplemental answer setting up the decision of the circuit court of appeals for the Sixth circuit in the case of Goodyear Tire & Rubber Co. v. Rubber Tire Wheel Co., 116 Fed. 363, as *res adjudicata*. I do not believe that the effect of making the Goodyear Tire & Rubber Company a party to this case was to enlarge the scope of the original litigation. The Goodyear Tire & Rubber Company only became a party to represent Samuel Everett Finley and the Finley Rubber Tire Company. The petition of the Goodyear Tire & Rubber Company to be made a party showed that Finley had ceased to sell its tires, and that the bond given by him, in pursuance of the order of the court, to prevent a preliminary injunction, had probably become ineffective, and it therefore desired to become a party for the purpose of carrying on the defense of the case. The issue here was as to the right of Finley and the Finley Rubber Tire Company to sell the tires he was making and selling in the territory embraced in his contract with the Rubber Tire Wheel Company, and which passed from him, by successive conveyances, to the Munford Rubber Tire Company; and, the infringement being clear, the estoppel operating between Finley and the complainants controls this litigation.

The application for leave to file the supplemental answer is denied. After considering the forms of decree handed me by the respective counsel, I have this day entered what I consider a proper decree in the case.

¶ 1. Pleading in infringement suits, see note to *Caldwell v. Powell*, 19 C. A. 595.

COCKER v. MONAGHAN MILLS et al.

(Circuit Court, D. South Carolina. December 27, 1902.)

1. AMENDMENT OF COMPLAINT—STATING NEW CAUSE OF ACTION.

Under the rule in South Carolina, the court cannot permit a complaint to be amended by the addition of allegations showing a liability on the part of a defendant against whom the original complaint states no cause of action, and when such proposed amendment is directly contradictory of the allegations of the original complaint.

On Motion for Leave to Amend Complaint.

Carey & McCullough, for plaintiff.

Wm. G. Sirrinc, L. O. Patterson, and F. F. Beattie, for defendants.

BRAWLEY, District Judge. The plaintiff brought her action in the court of common pleas for Greenville county against the Monaghan Mills. This complaint was amended by making the Flynt Building & Construction Company, a corporation of the state of Massachusetts, a party defendant also. This last-named corporation filed its petition for removal into this court on the ground that there was a separable controversy. The prayer of this petition was granted, and an order passed for the removal. When the case came here the defendant the Flynt Building & Construction Company filed a demurrer to the complaint as not setting out a cause of action against it. Before this demurrer came up for a hearing, the plaintiff asked leave to amend her complaint, as hereinafter stated. To reach a conclusion on this motion, a summary of the complaint as it was filed here is necessary.

After stating the corporate character of the defendants, the complaint proceeds: On January 28, 1901, the Monaghan Mills owned a certain brick building, three stories high, which it had constructed for the manufacture of cotton goods, in which it was having certain machinery and other appliances placed. The end of this building was not built of brick, but closed with a wooden partition, so that in the future the building could be enlarged. Alongside of this wooden end the Monaghan Mills had constructed a stairway leading from the bottom to the top floor, with doors entering the building on each floor, these doors being swung on the inside of the building, on the right. Persons having occasion to go from the ground to either floor were permitted and accustomed, if they desired, to use this stairway and these doors for this purpose. The door was unlocked and the stairway free. That on the said day of January the intestate of plaintiff was in the employ of the Sacco & Petty Machine Shops, a corporation which had sold to the Monaghan Mills certain machinery, and was under contract to place such machinery in said building as the Monaghan Mills should direct. That at the instance and request of the Monaghan Mills the said Sacco & Petty Machine Shops on that day directed plaintiff's intestate to go to the mill and report for orders. That plaintiff's intestate did go as directed, with tools and overalls and lunch, reported to the defendant the Monaghan Mills, and was instructed by it to place certain machinery on the third floor of said

building. That the intestate never had been in the building before, knew nothing of the conditions inside of it, and defendants failed to apprise him of said conditions, or warn him of any danger incident to approaching or entering the third floor by that stairway or door. That just inside the building, opposite to and within a few inches of the said door, was an open space or elevator shaft, through which the elevator of the defendant, the Monaghan Mills, could ascend and descend from and to the lowest floor. This shaft had no fencing, railing, or other protection around it, and was so close to the door that any one entering the door, and unaware of its existence, in one step would fall into it. That on that day the intestate, when directed by the Monaghan Mills to go on the third floor and place machinery thereon, went up the stairway, unaware of the danger, opened the door, took one step forward, and fell into and through the elevator shaft to the floor below, and was instantly killed. It will be observed that so far the complaint alleges the ownership of this building by the defendant the Monaghan Mills; its contract with the Sacco & Petty Machine Shops to place machinery in this building; that plaintiff's intestate was in the employ of this latter company, and instructed to report to the Monaghan Mills for orders; that the Monaghan Mills instructed him to put this machinery on this third floor; that, pursuant to these instructions of the Monaghan Mills, he went to the third floor, without warning or notice, and fell through the elevator shaft; there being no averment or suggestion that the Flynt Building & Construction Company knew of him or his purpose, or his instructions from the Monaghan Mills. The complaint then for the first time mentions the Flynt Building & Construction Company, as follows:

"That the defendant Flynt Building & Construction Company had the contract, so plaintiff is informed and believes, of erecting the said building, and turning the same over to the defendant Monaghan Mills complete; and under the terms of the said contract, so plaintiff is informed and believes, it was also the duty of this defendant to see that the said premises were safe and suitable, the elevator shaft securely guarded; and, under the terms of its contract with the said Monaghan Mills, it is also liable to this plaintiff for any damages which she may be entitled to recover in this action for the acts of negligence alleged in this complaint.

"But for the defendants' negligence, plaintiff's intestate would not have been killed on that occasion, and, in addition to the other acts of negligence herein above cited, plaintiff alleges that defendants were negligent more especially in leaving said open space or elevator shaft unfenced and unguarded and exposed so near the said door through which people were accustomed to enter; in having the door or entrance to the said third floor on the outside, at a point so dangerously near the said open space or elevator shaft; in allowing people to use the said stairway and door in entering the said building, while the said open space or elevator shaft was in that condition, and without warning them of such danger; in not warning plaintiff's intestate on this occasion of the danger in entering said building by means of the said stairway and door; and in not furnishing and pointing out to him a safe and suitable way of gaining an entrance into said building and his point of destination."

It is very clear from this that no cause of action is stated against the Flynt Building & Construction Company, and that the demurrer would hold. Now the plaintiff asks leave to amend the complaint as follows:

"By adding to paragraph 15 the following: 'By the terms of the said contract between the Flynt Building & Construction Company and the Monaghan Mills, the Flynt Building & Construction Company was an independent contractor, with the usual rights and liabilities of such; that the building mentioned in the said contract had never been completed, and had not been turned over to the Monaghan Mills, nor had the Monaghan Mills received the same; that the Flynt Building & Construction Company at the times herein mentioned was in the custody and control of the said building, and the plaintiff's intestate was there on the occasion alleged in the lawful discharge of a duty which he owed the Sacco & Petty Machine Shops, to do work under the contract between his employer and the said Monaghan Mills, and was there by the invitation of the defendant Flynt Building & Construction Company.'"

Up to this fifteenth paragraph the complaint had alleged that the Monaghan Mills was the owner of the building, had constructed the stairway with its doors, had contracted with the Sacco & Petty Company to place the machinery, had received the plaintiff's intestate as an employé of the company to do this work, and had instructed him to go and do it on this third floor. The amendment proposes to contradict this by stating that the Flynt Building & Construction Company, an independent contractor, had not finished the building, and had not turned over the building to the Monaghan Mills, which had not received it, and so the Flynt Company had custody and control of the building, and had invited the plaintiff's intestate to go to the building and put in the machinery. The amendment not only changes altogether the cause of action, by seeking to make the Flynt Building & Construction Company liable for all that is charged against the Monaghan Mills; but, if it be admitted, the whole structure and scope of the complaint must be changed, or else the several parts of the complaint will contradict each other. From the papers in the record it appears that the case against the Monaghan Mills was tried in the state court, and that, after hearing, the jury found for the defendant. This amendment proposes now to shift the allegations against the Monaghan Mills so as to bring them against the Flynt Building & Construction Company, and practically to obtain in this court a new trial of the case heard in the state court. A motion to amend is directed to the discretion of the court, and is not one of right. Under the circumstances of this case, this motion does not commend itself to the favorable opinion of the court.

It is urged for the plaintiff that, if the amendment be allowed, a cause of action will be stated against the present defendant. That may be true. But it is an entirely new cause of action, on grounds not alluded to in the complaint, and wholly inconsistent with the facts alleged in the complaint. In this matter of amendment this court follows the practice of the state court. *West v. Smith*, 101 U. S. 263, 12 L. Ed. 1130. Inasmuch as the granting or refusal of an amendment is always within the discretion of the court, the decided cases upon this point are more in the nature of advisory cases, and not controlling absolutely this discretion. The rule in South Carolina, where a very liberal practice in amendments exists, is that by such amendment plaintiff "cannot in any event make a new claim or state a new cause of action." *Kennerty v. Phosphate Co.*, 21 S. C. 242, 53 Am. Rep. 669. In *Lilly v. Railroad Co.*, 32 S. C. 142, 10 S. E. 932, the court held

"that when, upon examination of the complaint, it is found that no cause of action is stated, and if the amendment were allowed it would not simply supplement a faulty statement of a cause of action, by adding or striking out the name of a party, or by correcting a mistake in the name of a party, etc., or by inserting other allegations material to the cause, it would be absolutely giving a cause of action where none was alleged," and so the amendment could not be allowed. This case of *Lilly v. Railroad Co.* is cited and affirmed in *Whaley v. Lawton*, 57 S. C. 256, 35 S. E. 558, and the same doctrine stated. It is also cited and affirmed in *Harvey v. Hackney*, 35 S. C. 366, 14 S. E. 822. Also in *Ruberg v. Brown*, 50 S. C. 398, 27 S. E. 873, in which case the court say: "The Code does not authorize the substitution of a new cause of action by way of amendment. It authorizes amendments only when there is a faulty statement of a cause of action." And in the very late case of *Proctor v. Railroad Co.*, 64 S. C. 492, 42 S. E. 427, reiterating the same doctrine, and again quoting *Lilly v. Railroad Co.* The only case in conflict with this rule is *Hall v. Woodward*, 30 S. C. 564, 9 S. E. 684, in which Judge Wallace, on circuit, allowed an amendment to an answer adding another defense. If this case changed the rule, it is overruled by the subsequent cases of *Lilly v. Railroad Co.*, *Whaley v. Lawton*, *Ruberg v. Brown*, and *Proctor v. Railroad Co.*, supra. But the case only held that the amendment allowed did not come within the restriction of section 194 of the Code of Civil Procedure. It is evident that it was sustained "because large powers of amendment are given to the court, and the exercise of this power, being discretionary, will not be interfered with, except for abuse of discretion." *Heyward v. Williams*, 48 S. C. 564, 26 S. E. 797.

Upon the whole, inasmuch as the complaint, as it now stands, states no duty whatever on the part of this defendant to the plaintiff's intestate, and no facts which can give a cause of action against it, and inasmuch, also, if this amendment be allowed, the allegations made in it are inconsistent with and contradictions to the other parts of the complaint, substituting by way of amendment a new cause of action, it cannot be allowed.

The motion to amend is dismissed.

RICHMOND GUANO CO. v. FARMERS' COTTON SEED OIL MILL & GINNERY et al.

(Circuit Court, D. South Carolina. December 27, 1902.)

1. CORPORATIONS—LIMITATION OF POWERS BY PURPOSES OF INCORPORATION—CONTRACTS ULTRA VIRES.

A corporation organized "to build and operate a cotton seed oil mill and ginnery in connection therewith, to compress cotton seed oil, to buy cotton seed, to sell their products, to manipulate and compound cotton seed meal with other substances and elements so as to make fertilizers to be sold for fertilizing lands, and to gin and compress cotton into bales for the market," has no power to engage in the business of selling a fertilizer manufactured by another, which must be sold in the condition in which it is received, making as a profit what it can obtain above the invoice price; and notes given by the corporation for such invoice price are ultra vires and void.

2. SAME—DISTRIBUTION OF ASSETS IN INSOLVENCY—AGREEMENT FOR ATTORNEY FEES IN NOTES.

In South Carolina, where an agreement in a note to pay a stipulated per cent. as attorney's fees in case of suit thereon is valid, where a court of equity in a creditors' suit to wind up an insolvent corporation enjoins actions at law to collect claims, and requires all creditors to prove their claims therein, holders of notes containing such agreements, who employ attorneys, are entitled to the stipulated per cent. on the dividends received as attorney's fees from the fund distributed.

In Equity. Creditors' suit for winding up the affairs of an insolvent corporation.

Heyward, Dean & Earle, for complainant.

Haynsworth, Parker & Patterson, for defendants.

B. M. Shuman, for certain creditors.

BRAWLEY, District Judge. This case now comes up after the report of the special master with the testimony. Three matters are presented for consideration: (1) Whether the claim of the Richmond Guano Company can be allowed; (2) whether the 10 per cent. for attorney's fees provided for in certain notes of the defendant company can be charged against the fund; (3) whether the City National Bank can be charged with any part of such fee as may be allowed the solicitor of complainant for filing the bill.

As to the claim of the Richmond Guano Company. It is alleged that the transaction between this company and the Farmers' Cotton Seed Oil & Ginnery Company was one not within the scope of the charter of the last-named corporation, and so, being ultra vires, is void. This contention is made by the City National Bank, a creditor of that corporation, and must be considered. 5 Thomp. Corp. § 6034. When the motion was made for the appointment of a permanent receiver, the same question was made by the City National Bank. It was not passed upon, because at that time it was not necessary. The bill was a creditors' bill. So the question was reserved until proof of claims could be made and all parties were before the court. The Farmers' Cotton Seed Oil Mill & Ginnery Company was chartered under the general law of South Carolina on May 14, 1900. "The general purpose of the corporation and the nature of the business it proposes to do is to build and establish a cotton seed oil mill and ginnery in connection therewith, and to compress cotton seed oil, to buy cotton seed, to sell their products, manipulate and compound cotton seed meal with other substances and elements so as to make fertilizers to be sold for fertilizing lands, to gin and compress cotton into bales for the market." Under this charter, with these declared objects, the corporation began business. The outlines of the doctrine of ultra vires, and the reasons upon which it rests, have been fully discussed and clearly stated in many of the decisions of the supreme court. In *Green Bay & M. R. Co. v. Union Steamboat Co.*, 107 U. S. 98, 2 Sup. Ct. 221, 27 L. Ed. 413, it is thus expressed:

"The charter of a corporation, read in connection with the general laws applicable thereto, is the measure of its powers, and a contract manifestly beyond these powers will not sustain an action against the corporation. But

whatever under the charter and other general laws, reasonably construed, may be fully regarded as incidental to the objects for which the corporation is created, is not to be taken as prohibited."

This rule and the language used in it has been repeatedly recognized and affirmed. *Ft. Worth City Co. v. Smith Bridge Co.*, 151 U. S. 294, 14 Sup. Ct. 339, 38 L. Ed. 167; *Pittsburgh, C. & St. L. Ry. Co. v. Keokuk & H. Bridge Co.*, 131 U. S. 385, 9 Sup. Ct. 770, 33 L. Ed. 157; *Navigation Co. v. Hooper*, 160 U. S. 514, 16 Sup. Ct. 379, 40 L. Ed. 515. Lord Chancellor Selborne, in *Attorney General v. Great Eastern Ry. Co.*, 5 App. Cas. 473, uses this language:

"This doctrine [ultra vires] ought to be reasonably, and not unreasonably, understood and applied, and that whatever may be fairly regarded as incidental to or consequential upon those things which the legislature has authorized ought not, unless expressly prohibited, to be held by judicial construction to be ultra vires."

This statement of the doctrine is adopted and approved in *Railroad Co. v. Hooper*, 160 U. S. 514, 16 Sup. Ct. 379, 40 L. Ed. 515. Bigelow, C. J., in *Brown v. Winnissimmet Co.*, 11 Allen, 326, says:

"We know of no rule or principle by which an act creating a corporation for certain specific objects or to carry on a particular trade or business is to be strictly construed as prohibitory of all other dealings or transactions not coming within the exact scope of those designated. Undoubtedly, the main business of a corporation is to be confined to that class of operations which properly appertain to the general purposes for which its charter was granted. But it may also enter into contracts and engage in transactions which are incidental or auxiliary to its main business, or which may become necessary, expedient, or profitable in the care and management of the property which it is authorized to hold under the act by which it is created."

There can be no doubt that a contract of a corporation ultra vires is absolutely void, and of no legal effect, incapable of ratification by either party. *Central Transp. Co. v. Pullman's Palace Car Co.*, 139 U. S. 59, 60, 11 Sup. Ct. 478, 35 L. Ed. 55.

The Richmond Guano Company and the Farmers' Oil & Ginnery Company made two contracts identical in character; one on March 4, 1901, the other December 22, 1902. The contracts are in form offers to the Cotton Seed Oil Company to furnish it this season, delivered in car lots, f. o. b. at Greenville, certain fertilizers at certain cash and credit prices, to be sold by the Cotton Seed Oil Company as agent for Richmond Guano Company. All cash sales to be accounted for on or before May 1, 1901. Notes for the remainder to be given by the Cotton Seed Oil Company, payable one-third November 1, 1901, one-third November 15, 1901, and one-third December 1, 1901. The Cotton Seed Oil Company agrees further that all fertilizers ordered by it and all proceeds therefrom are the property of Richmond Guano Company, held in trust by the Cotton Seed Oil Company for its account until these notes are paid in full. It also agrees to take bonds or notes for all sales made by it on credit, and to turn all these over to the Richmond Guano Company as collateral security for said notes. Provision is also made for shipping goods to sundry other points than Greenville at slightly increased rates. Under these contracts 1,500 tons of fertilizers were shipped in sacks, each sack having on it a guaranty of the analysis. And pursuant to the agreement these notes were executed by the

Farmers' Cotton Seed Oil & Ginnery Company to the Richmond Guano Company, each dated May 18, 1901, each bearing interest after maturity at rate of 6 per cent. per annum, each agreeing to pay 10 per cent. attorney's commissions if collected by an attorney by suit or otherwise,—one due November 1, 1901, for \$6,200; another due November 15, 1901, for \$6,191.30; the third due December 1, 1901, for \$1,200. The notes given for the sale of these fertilizers were all assigned to and are in the possession of the Richmond Guano Company as collateral for three notes. An exhibit is with the report, showing that on these collaterals and from other sources there has been paid on the three notes \$14,399.14, leaving a balance of \$4,192.16 of principal and \$290.74 of interest,—in all, \$4,482.90,—unpaid. There is no report as to the correctness of this in the record. It is impossible to call these contracts sales of goods. They expressly stipulate that all the fertilizers ordered and the proceeds thereof are the property of the Richmond Guano Company, to be held in trust by the Cotton Seed Oil Company for the account of Richmond Guano Company. The contracts are really an agreement by the Farmers' Cotton Seed Oil & Ginnery Company to receive fertilizers from the Richmond Guano Company, sell them for its account, binding itself for the invoice price of the shipments, and looking for its compensation to the sums over and above the invoice prices which it could obtain. Is this character of business within the scope of, or incidental to, the business authorized by the charter? The charter authorizes it to build and establish a cotton seed oil mill and ginnery in connection therewith, to compress cotton seed oil, to buy cotton seed, to sell their products, to manipulate and compound cotton seed meal with other substances and elements so as to make fertilizers to be sold for fertilizing lands, and to gin and compress cotton in bales for the market." These contracts provide for the sale by this corporation, for a hoped-for profit, of fertilizers manufactured by the Richmond Guano Company, for the account of this last-named company; the same to be shipped in bags, having on them a guaranteed analysis, which would be of no value if the bags were opened and other ingredients put in. It is said in the evidence and in argument that farmers mixed cotton seed meal with fertilizers, and that the sale of these fertilizers helped to sell the cotton seed meal. But in the same way the sale of any other desirable article might help the sale of meal, but this would not authorize the company to keep a general store. In *Davis v. Railroad Co.*, 131 Mass. 258, 41 Am. Rep. 221, it was held that a corporation organized under a general act, the purpose of whose organization was the manufacture and sale of reed organs and other musical instruments, could not, in addition to the power to manufacture and sell goods of a particular description, partake in a guaranty of the profits of an enterprise that may be expected to increase the use or demand for such goods. "An incidental power," says the supreme court of Connecticut in *Hood v. Railroad Co.*, 22 Conn. 1, "is one that is directly and immediately appropriate to the execution of the power granted, and not one that has a slight or remote relation to it. * * * It would be absurd to hold that the directors, under the idea of incidental powers, might do everything

which they thought would bring passengers to the road. Such a limit is no limit. If they could do this under such a pretense, they could, by direct appropriation of the company funds, build manufacturing villages along the road, and run steamboats to New York, for this might increase their business." It would be going very far to say that a charter authorizing a corporation to manufacture and sell the products of its manufacture will also authorize the selling of the manufactured products of a wholly different corporation for the hope of profit. The contract is ultra vires. In so far as it is executory it is void. The balance said to be due constitutes no claim on the fund.

2. Is the 10 per cent. attorney's fee provided for in some of the notes chargeable upon the fund? It has been held in South Carolina that provision made in a note for the payment of a commission to an attorney in case of suit is perfectly legal and binding. *Branyon v. Kay*, 33 S. C. 283, 11 S. E. 970; *Association v. Hoffman*, 50 S. C. 303, 27 S. E. 692; *Bird v. Kendall*, 62 S. C. 192, 40 S. E. 142. And if, by order of a court of equity, individual suits are enjoined, a creditor who comes in by an attorney, and proves his claim, is entitled to the benefit of this provision. *Westfield v. Westfield*, 13 S. C. 485. Any creditor who is represented by an attorney, and whose note contains such a provision, is entitled to receive dividend on the value of his note, and, in addition, 10 per cent. on the actual amount of the dividend as fee for his attorney.

3. It follows that the fee of the complainant's solicitor cannot be allowed out of the fund.

THE UNDERWRITER.

(District Court, D. Massachusetts. August 1, 1902.)

No. 1,007.

1. MARITIME LIENS—REPAIRS AND SUPPLIES—AMERICAN RULE.

Maritime liens for supplies and repairs are of ancient origin, and were recognized both in England and on the continent to bind both foreign and domestic vessels. Both have generally been bound upon the continent, and also by the admiralty law of England, but such law was denied enforcement by writs of prohibition from the English common-law courts in the case of foreign and domestic vessels alike. In the American admiralty law there has been a general tendency to hold a vessel liable for her repairs and supplies, unless the owner, to the knowledge of the furnisher, has declined to allow the lien. This general and imperfectly developed rule is subject to exceptions, presumptions, and counter presumptions. Where the owner, to the knowledge of the furnisher at the time of supply, refuses to allow the lien to arise, it does not exist or is deemed to be waived.

2. SAME—CONSTRUCTION OF CHARTER—NOTICE OF LIMITATION OF MASTER'S AUTHORITY.

A charter party providing that the charterer shall provide and pay for all the coal used by the vessel, and that the master, although appointed by the owner, shall be under the orders and direction of the charterer as

¶ 1. Maritime liens for supplies and services, see note to *The George Dumois*, 15 C. C. A. 679.

regards employment, agency, or other arrangements, is not merely a contract between the parties which binds the charterer to reimburse the owner for coal paid for by the latter, but is also a limitation on the authority of the master to bind the owner or the vessel for such supplies; and no lien upon the vessel exists in favor of a libellant who supplied coal on the order of the master in a foreign port, but which was not a port of distress, and was merely across the river from the home port, where the owner resided, and no actual necessity was shown for pledging the credit of the vessel, and where libellant knew the vessel to be under charter, and was put upon inquiry as to the terms of the charter.

In Admiralty. Suit in rem to establish and enforce a maritime lien for supplies.

Nichols & Cobb, for libellant.

Frederic Dodge and Frederic Cunningham, for respondent.

LOWELL, District Judge. This was a libel filed against the tug Underwriter for the value of coal furnished her in a foreign port while under charter to the Atlantic Transportation Company. The charter provided that the charterer should pay for coal. The coal was furnished upon the order of the master. The evidence is somewhat conflicting, but I find that the following facts are established:

The libellant, through its officers and agents, either knew that the Underwriter was under charter to the transportation company, or knew enough to put upon inquiry a reasonable man who wished to know if there was such a charter. The libellant did not know that the charter expressly provided for the furnishing of supplies by the charterer, but it was put upon inquiry concerning this fact also, and might easily have ascertained it. The coal was ordered by the master. The libellant charged the coal to the tug and owners, and in fact looked to the tug for payment. There was no contract made between the charterer and the libellant to furnish the coal. The correspondence between the two, if any existed, amounted to no more than a request by the charterer for the libellant's price list. If the libellant had a right to look to the vessel for the coal, it did not waive that right by any act. No actual necessity for pledging the credit of the vessel was shown. I do not think that the conversation between Capt. Wiley and Mr. Abernethy regarding the credit given to the tug was proved. Under these circumstances the court has to determine if a lien exists where, in a foreign port, necessary supplies are ordered by the master of a vessel known by the libellant to be under a charter which provides for the payment for supplies by the charterer. No reference has been made to any statute, and the case must be decided by the general admiralty law. This question has not always received the same answer in the courts of the United States, and similar answers have not always rested upon like grounds. For this reason a somewhat extended examination of the history of the lien of a materialman upon a vessel seems desirable.

The admiralty law on this subject administered in the federal courts is derived rather from the civil law and the maritime law of continental Europe than from the common law of England. Dig. 42, 5, 26, 34, provides, "Qui in navem extruendam, vel instruendam, credit, vel etiam emendam, privilegium habet." "Quodquis navis fabricandæ,

vel emendæ, vel armandæ vel instruendæ causa, vel quoque modo crediderit, vel ob navem venditam petat, habet privilegium post fiscum." See Dig. 49, 14, 17. If this language be taken literally, and if "privilegium" be translated "lien," then, so far as the Roman law is concerned, the question is answered, and a lien is created by a mere contribution to the construction or maintenance of a vessel, irrespective of the authority of the person ordering the work or supplies. The lien depends upon the fact that the materialman has contributed to the existence or maintenance of the object upon which he claims the lien. See, also, Dig. 20, 4, 5. This construction has been put upon these passages by some civilians and by some courts of England and the United States. See *The Sandwich*, 1 Pet. Adm. 233, note (s. c. Fed. Cas. No. 13,409). This seems to have been the opinion of Mr. Justice Story. See *The Nestor*, 1 Sumn. 73, 79, Fed. Cas. No. 10,126; *The General Smith*, 4 Wheat. 438, 4 L. Ed. 609. But in *The Young Mechanic*, 2 Curt. 404, Fed. Cas. No. 18,180, Mr. Justice Curtis pointed out the difference between "lien" and "privilegium." A privilege may mean no more than a general priority in the distribution of the debtor's assets. See Desjardins, *Droit Com. Mar.* 1, 213. See, also, Pardessus, *Lois Mar.* I, p. 98, note 4, page 113, note 1, and page 119, note 3, where the author states that, according to the best opinion, an express agreement is necessary to create the lien mentioned in the texts of the digest above quoted. If this be true, then these texts prove no more than that an express hypothecation of the vessel to pay the debt of a materialman gives priority over other liens, hypothecations, and conveyances, and is inferior only to the fisc. Under this construction of the Digest, no lien exists by force of the repairs and supplies without an express hypothecation of the vessel. The authority to hypothecate, therefore, must be important.

Another text of the Digest seems to have affected more considerably the later continental law regarding the rights of the materialman. Dig. 14, 1, 1-7. "De exercitoria actione." This text deals with the authority of the master to bind the owner of the vessel for repairs, supplies, seamen's wages, etc., and his authority to borrow money for these purposes. It declares how far the owner is bound if the master misapplies the money borrowed; and it makes the right of action against the owner to depend, not upon the actual maintenance of the ship, for the right of action may exist where the ship gets no benefit, but upon the authority of the master to contract, reasonably supposed to exist by the materialman or lender. How far this text deals with a lien upon the ship, rather than with the personal liability of the owner, is not clear.

The maritime law of England was affected more directly by the maritime laws of continental Europe than by the Roman law. As applied in the English admiralty, the civil law was usually, though not always, first passed through a later continental medium. It is to "the ancient collections of sea laws," as Mr. Justice Curtis calls them, rather than to the Digest, that reference is commonly made by modern judges; and it was these collections, rather than the civil law at large, by which the commons of England in the fifteenth century

wished the English courts of admiralty to be governed. 1 Rolle, Abr. 528; 3 Rolls Parl. 498. Of these laws, in their relation to the Roman law and to maritime liens, Mr. Justice Curtis said in *The Young Mechanic*, 2 Curt. 404, 408, Fed. Cas. No. 18,180:

"Whether the texts of the Roman law were misunderstood, and so were the source of the existing usages, or whether it was only intended to adapt them to those usages which had already obtained, it is certain that in the general maritime law of Europe privileged hypothecations were tacitly conferred in the cases in which what we term 'liens' now exist. It is true we do not find their precise nature described in any of the ancient collections of sea laws, so far as I have discovered. These laws were, generally, simple practical rules, often partaking of the rudeness of the age in which they were compiled, dealing rarely with abstractions, containing few definitions, and, with the exception of the customs and ordinances of Catalonia and Arragon, collected by Pardessus in volume 5, p. 333 et seq., and they are not laws of procedure. In the *Consulat de la Mer*, the most ancient and important of all, there is no definition of a maritime lien, nor any account of the way in which it was to be worked out. Its usual formula is, simply, the ship ought to be sold, and the debt or damage paid from its price. And so, when the personal liability of the master is ordained, it is only said he ought to be put into the power of the magistrate. See chapter 289. But that the right or privilege of the seaman in the ship as a security for his wages (chapters 138, 193), of the merchant for injury or loss of his goods, etc. (chapters 59, 254, 259, 227, 106, 63), or for the price of his goods sold to raise money for the necessities of the ship (chapter 107), was a real right,—a jus in re, in contradistinction to a mere personal privilege to be paid in a concourse of creditors,—I have no doubt. In the *Laws of Wisbuy*¹ this is clearly shown. Emerigon (*Con. a la Grosse*, c. 124, § 4) and Boulay-Paty (*Cours de Droit Com.* vol. 1, p. 38), translate the forty-fifth article of these laws respecting the right of a merchant whose goods have been sold to supply the necessities of the vessel, or who has lent money for the same purpose, 'Auront special hypothèque et suite le navire.' See, also, 1 Pardessus, *Col. des Lois Mar.* 492, art. 43. Le Guidon (chapter 19, arts. 1, 2; Pardessus, *Col. des Lois Mar.* 424) denominates such a right 'special hypothèque.'"

Many other passages in various maritime laws show that a lien of some sort upon the ship was contemplated as the result of repairing or supplying her. By the *Laws of Oleron*,² dating from the thirteenth century, which had especial authority in England, *Pard.* I, 323, art. 1, the master may, under some circumstances, pledge part of the tackle of the ship in a foreign port to raise money for the needs of the ship. See the reproduction of the *Judgments of Oleron* in the *Judgments of Damme*, *Pard.* I, 371, in the *Castilian Law*, *Pard.* VI, 57, and in the *Laws of Wisbuy*,¹ art. 15, *Pard.* I, 471. See the *Laws of Denmark*, *Pard.* III, 298, 265. By the *Laws of Hamburg*, *Pard.* III, 352, 367, the tackle could be pledged for provisions in a foreign port, but not the ship. If, however, the master sold the cargo for this purpose, as apparently he had the right to do, the owner of the cargo sold had a lien upon the ship valid as against a purchaser. By the *Laws of Genoa*, *Pard.* IV, 520, it is implied, if not precisely stated, that for necessities a master may bind the vessel, but not the owner personally. So the *Ordinance of Trani* of 1063, *Pard.* V, 247, permits the master to pledge the ship in case of injury by sea peril or of capture by pirates. By the *Laws of Malta* of 1597, *Pard.* VI, 341, the captain can borrow in a port where the owners do not reside by written instrument, which declares the necessity of the borrowing. By this instrument the ship is bound. Other laws or

¹ 30 Fed. Cas. 1189.

² 30 Fed. Cas. 1171.

rules give authority to the master to pledge for supplies, and perhaps for repairs, even in a home port, the share in a vessel of a part owner who refuses to contribute proportionally to the maintenance of the vessel. A formal hypothecation is required, and formal summons to the delinquent owner. Consolato, *Pard.* II, 223. See Law of Ancona 1397, *Pard.* V, 118. By the law of Sweden, if the other owners furnished the supplies, the delinquent owner's share was *ex ipso facto* hypothecated to them. *Pard.* III, 160.

It is not necessary even to cite the laws giving a master authority to sell part of the cargo in order to repair or provision his ship. The connection of this authority with the right to create a lien upon the ship itself illustrates, however, the nature of this lien. We may pass over, likewise, the laws which deal with the binding of the owner of a vessel by the contracts of its master acting as his agent or servant, though these last also illustrate the nature of the lien of the materialman. There are laws which deal with the lien apart from the liability of the owner. Thus, by the customs of Amsterdam, *Pard.* I, 420, if the cargo is sold to supply the ship, its owner has a lien for its price upon the vessel, irrespective of a change in the vessel's ownership. See the Consolato, *Pard.* II, 110. By the Consolato, *Pard.* II, 225, the master may borrow in a port where no owner is present, and there is necessity. In this case all the body of the ship shall pay the loan, and no owner shall contest it. By the Law of Sweden, *Pard.* III, 159, the owners can escape liability upon the master's contract by abandoning the ship,—a rule which seems to imply a lien.

These varying provisions of law, so often referred to in the judgments of English and American courts, and not exhaustively cited here, make the peculiar rights of the materialman against the ship, whatever these may be, depend in general upon the authority vested in the master, in case of need and in the absence of the owner, to deal with the owner's property. The authority of the master must be shown in order to create a lien by hypothecation. There must be sufficient evidence of necessity and of the owner's absence, for when the owner is present the necessity is his, and not that of the master or ship. For these reasons it has been supposed that the general maritime law gives to a materialman no lien upon a ship except in case of necessity in a foreign port. But, notwithstanding the provisions of the various continental maritime codes already referred to, there are weighty considerations which suggest that a privilege or lien or right to proceed directly against the ship was given to the materialman, which attached in a domestic port and apart from any supposed necessity. Thus the Law of Sweden, *Pard.* III, 169, provided that one who lent money for the construction or maintenance of a ship might take a receipt, called a "bilbref," formally acknowledged, which gave him a lien on the ship superior even to that of a bottomry bond. See the similar provision in Denmark, *Pard.* III, 301. See the Maritime Ordonnance of Arragon of 1340, *Pard.* VI, 359, which gave a lien to the materialman and laborer in the construction of a ship which had not yet sailed. See *Id.* 389. See, also, as to the lien of workmen in building a vessel, Consolato, *Pard.* II, 59, VI, 389, and see, generally, Desjardins, I, 214-219. This appears most

plainly from the French Ordonnance de la Marine, book 1, tit. 14, arts. 16, 17, Pard. IV, 345. The prior history of these provisions is given summarily in Valroger I, 79 et seq. See, also, Desj. I, 206. By this code creditors for money lent during the last voyage have priority of payment after the seamen. After them come creditors who have lent money for repairs and supplies furnished to the ship before its sailing. If the ship has not made a voyage, the workmen and the materialmen are to be paid first of all. From this it appears that all materialmen have a right against the ship superior to that of the general creditors of the owner, though the materialman in a home port is postponed to the materialman abroad. It is very unlikely that these privileges or liens thus allowed by the Ordonnance were created by it. Probably the provisions cited expressed, perhaps with some slight change, the rule of law already existing. The French code adopted substantially these provisions of the Ordonnance, but provided that the claims of the several classes of creditors should be evidenced with certain formalities. (This provision did not apply to claims of the workmen themselves.) In adopting the French code many continental countries have adopted substantially the same provisions. See Desjardins I, p. 258 et seq., 277. Upon the whole, we have considerable evidence that the continental nations, or many of them, early recognized a lien arising from the furnishing of repairs or supplies, even in the home port. There seems an increasing tendency, however, to require that the debt thus creating the lien should be evidenced in some formal manner.

It remains to consider the law of England. The English jurisprudence relating to maritime affairs is so peculiar, and its peculiarities have affected so considerably the law of maritime liens in this country, that some general remarks must be made concerning it, even at the risk of repeating the commonplaces of admiralty. The law administered by the English court of admiralty has always been in theory a complete system for the administration of justice in maritime affairs. Alone, for the most part, the court of admiralty has had the administration of this system, and that it interpreted and applied the system correctly nobody doubted. But there was grave and long-continued dispute between the court of admiralty and the other courts concerning the boundaries which separated their several jurisdictions. Each sought to restrain the other from encroachment. Sometimes the court of admiralty punished for contempt those who in cases deemed to be maritime sought relief elsewhere. *Gorham v. Granger*, Select Pleas in the Court of Admiralty II, p. lxxviii; *Corsini v. Hangar*, Id. p. lxxi. Sometimes it inhibited another court directly. *Sewell v. Norman*, Sel. Pl. I, 75; *Wellys v. Felton*, Id. 78. Sometimes it did both. *Legge v. More*, Id. 83. On the other hand, it appears that the jurisdiction of the court of admiralty was early restrained by writs of certiorari (*Sewell v. Norman*, Sel. Pl. I, p. lxxvi); of supersedeas (*Chapillon v. Bird*, Id. I, p. lxxiv, 29; *Struce v. Sleighter*, Id. I, lxxv, 45. See II, p. xli); of mandamus, perhaps (see *Bremer v. Porter*, I, lxxv, 59); and of prohibition. After the beginning of the seventeenth century this restraint was commonly operated by a writ of prohibition, issued by the court of king's bench,

while the court of admiralty ceased to inhibit proceedings elsewhere, and was generally put upon the defensive. In some cases the privy council had intervened, and had restrained both sides, by acting as arbiter between them. Sel. Pl. II, 113. The courts of chancery and common law did not interfere with the court of admiralty because the latter was deemed to err in substantive law, but because it and its system of law were, by acts of parliament, excluded from the cognizance of many—even of most—maritime matters, which, by virtue of these acts of parliament, were held cognizable only by the courts and the system of common law. The question so much debated, how far the courts of common law were within their rights in issuing these prohibitions, need not be discussed here. From the seventeenth century onwards they could and did impose their will upon the courts of admiralty. Where the jurisdiction of the admiralty was admitted, its system of law was admitted to govern as matter of course, and the courts of common law in no wise interfered. Thus, in *Tremoulin v. Sands* (1697) Comb. 462, Lord Holt said:

“It does not appear here in the libel that the admiralty court hath any jurisdiction, and, wherever they have not original jurisdiction of the cause, tho’ there arise a question in it that is proper for their conusance, yet that alters not nor takes away the power of the common law; but if they have jurisdiction of the original, tho’ a question ariseth proper for the common law, yet they shall try that; and after sentence, if it appear that the matter contain’d in the libel is triable at common law, we will grant a prohibition.”

See *Greenway v. Barker*, Godb. 260.

Indeed, had a court of admiralty attempted to apply to a case before it any system of law but its own, it would have erred admittedly. About 1400 the Commons asked the admiral to change this system, and to govern himself thereafter by the common law; but the request was refused. See Sel. Pl. II, p. xlii; 1 Rolle, Abr. 528. A court of equity restrains the enforcement in a court of common law of the penalty of a bond, and this practice has analogies to the treatment of the admiralty court by the king’s bench. Even the granting of a prohibition to the admiralty was not always deemed to be *strictissimi juris*, and equitable considerations were sometimes admitted to affect the action of the court of common law. Thus, in *Martin v. Green* (1665) 1 Keb. 730, a prohibition was sought against a libel for a collision caused by the tide. It was urged that an action on the case was the only remedy, but Chief Justice Hyde doubted, because the owners of the offending vessel were not known, and so there was no available remedy at law. The other judges said this fact did not give jurisdiction, but finally the prohibition was granted only upon a disclosure of the owner’s name, made in order that the libellant might have an effective remedy at law. See *Brown v. Franklyn*, Carth. 474; *Anon.*, 12 Rep. 77. But the analogy between injunctions and prohibitions is not complete. No one disputed the jurisdiction of the common-law court to give judgment for the penalty. The prohibition by injunction applied only to the party plaintiff. On the other hand, the writ of prohibition was addressed directly to the admiralty court. Not being deprived of any part of its formal jurisdiction, the court of common law was not deemed to be aggrieved

by the practical restraint imposed upon its authority by the chancellor. The court of admiralty, on the other hand, being deprived directly of what it deemed its proper jurisdiction, protested for century after century; at times more or less successfully, at times with some popular support. It never abandoned its claim to the disputed jurisdiction, and actually entertained jurisdiction in numberless cases wherein it would have been prohibited had the respondent applied for a prohibition. For this reason the prohibitions issued by the common-law courts do not show the extent of the actual jurisdiction of the admiralty court, while the unprohibited suits in the court of admiralty do not show the limits imposed upon that court's jurisdiction by the courts of common law. This fact must be borne in mind throughout our examination, and also that a maritime lien may be denied operation for two different reasons: (a) Because it is not given by the admiralty law; and (b) because, though admitted to be given by the admiralty law, yet, in the case supposed, the admiralty law is not permitted to operate.

Let us next consider what was the law regarding the lien of a materialman according to that system of maritime law administered by the English court of admiralty. This is not the same thing as the right which the materialman was actually permitted to enforce in England, for the courts of common law often prohibited the court of admiralty in this respect. What was the right of the materialman according to that ideally existent, but often unenforceable, system which has been already mentioned? The printed material for the study of this system is still scanty, and ten years ago was almost wholly wanting. The publication by the Selden Society in 1892 and 1897 of two volumes of *Select Pleas of the Court of Admiralty*, edited by Mr. Marsden, has let in a flood of light upon questions much disputed in courts of England and America. Instead of conjecturing what may have been the practice and substantial jurisprudence of the English court of admiralty in the sixteenth century, we now know for certain by the perusal of decided cases. Hence it follows that the ordinary student of to-day may set right in some matters of history the great judges of the past. Even Mr. Marsden's selections leave us still ignorant of much that we should like to know. Outside his two volumes, we are confined to (1) statements made in later reported cases by English admiralty judges, who inherited the traditions of the admiralty, and to some extent may have had knowledge of its unprinted records; (2) casual, and often unauthorized, expressions found in publications of various sorts; and (3) reports of cases in the courts of common law where prohibitions to the court of admiralty were sought. The earliest regular English admiralty reports date from the latter part of the eighteenth century, when the courts of common law had triumphed, and the defeated court of admiralty had begun to forget how extensive was the jurisdiction it once had claimed.

To ascertain the law of maritime lien as applied by the English courts of admiralty, it is necessary first to consider briefly the nature of their process, and especially that of their process so-called "in rem." Learned judges have said that proceedings in rem in the

English court of admiralty were introduced later than proceedings in personam; that originally they were only auxiliary to the latter, had only to constrain the appearance of the real party to be charged. They are, it has been said, to be taken as analogous to proceedings by foreign attachment. See *The Johann Friederich*, 1 W. Rob. Adm. 37; *The Merchant*, Abb. Adm. 1, Fed. Cas. No. 9,434; *The Dundee*, 1 Hagg. Adm. 110; *The City of Norwalk* (D. C.) 55 Fed. 98; *The Dictator* [1892] Prob. Div. 304; *The Gemma* [1899] Prob. Div. 285. With this agrees to a considerable extent Clerke's *Praxis*, written in the latter part of the sixteenth century, and Zouch's *Admiralty*. Early cases give some support to this theory. Thus, anchors, etc., were arrested in a suit to enforce a bond to carry out a charter party, without suggestion that they were connected with the ship chartered. *Fuller v. Thorne*, Sel. Pl. I, 38. See, also, *The John of Alen*, Id. 53; *Crockye v. Goods of Cruse*, Id. II, 81. Seamen were permitted to enforce a claim for wages earned in one vessel against another vessel of the same owner. *Thorneton v. The Elizabeth Bonaventure*, Id. 131. Mr. Marsden observes generally: "The fact that goods and ships that had no connection with the cause of action, except as belonging to the defendant, were subject to arrest, points to the conclusion that arrest was mere procedure, and that its only object was to obtain security that judgment should be satisfied." Id. I, p. lxxii. Even where the vessel had been expressly hypothecated, suit was brought against both the ship and the owner, and the decree might go against the owner personally. *Draper v. The Black Greyhound*, Id. II, 155; *Draper v. The Fortune*, Id. 156. See *Gale v. Brown*, Id. I, 55; *Harrison v. Stubbarde*, Id. 62. Apparently the proceedings in these cases were substantially like those in which the admiralty took jurisdiction to collect any debt by the attachment of any goods on the Thames. *Warner v. Wheler*, Id. I, 117.

But the analogy thus stated between the process of arrest in the admiralty and the process of foreign attachment is not complete. As was said by Sir John Jervis in *The Bold Buccleugh*, 7 Moore, P. C. 267:

"The foreign attachment is founded upon a plaint against the principal debtor, and must be returned nihil before any step can be taken against the garnishee. The proceedings in rem, whether for wages, salvage, collision, or on bottomry, go against the ship in the first instance. In the former case the proceedings are in personam; in the latter they are in rem. The attachment, like a common-law distringas, is merely for the purpose of compelling an appearance; and, if the defendant appears within a year and a day, even after judgment and execution against the garnishee, and puts in bail, the attachment is at an end. If the owners do not appear to the warrant arresting the ship, the proceedings go on without reference to their default, and the decree is confined exclusively to the vessel. Many other distinctions will be found upon reference to the notes to *Turbill's Case*, 1 Saund. 67, note 1. It is not correct, therefore, to say, that the proceeding in rem is in all respects analogous to the proceeding by foreign attachment, and that the former is merely to compel an appearance, because the latter is undoubtedly for that purpose only."

When the cases reported in the Select Pleas are examined individually, it appears that in some of them the arrest of the vessel was something more than a process analogous to foreign attachment. This is true where the office of the admiral was promoted against

goods alleged to be forfeited. See *Officium Domini v. Pirate Goods*, Sel. Pl. II, 84. Here the arrest of the goods had an object other than that of obtaining security for satisfaction of judgment. So, where a prize was libeled by her captors. *Gonner v. Pattyson*, Id. 106. Yet the proceedings were in much the usual form, and all persons having claim were cited to appear *pro interesse suo*. See *Officium Domini v. Goods ex a Hamburg Ship*, Id. 91. So where forfeiture was sought of a ship and goods belonging to an interloper in a monopoly. *Merchant Adventurers Co. v. The Elizabeth George*, Id. 150. So where a ship taken by pirates was returned to its true owner. *Officium Domini v. The Eugenius*, Id. 99. And so, generally, in possessory and petitory actions, where the return of ship or goods was sought by their owner. See *Mason v. Trippe*, Id. 117. So in cases of salvage. Again, where the ship had been expressly hypothecated, and was arrested to enforce the hypothecation, although the form of process resembled generally that employed to collect an ordinary debt, yet the arrest availed something more than to compel the owner's attendance. See *Fleminge v. The Haddocke*, Id. 191. Though the form of the decree might be personal or alternative, yet the hypothecation was not without effect upon the practical result of the suit. Again, by reason of the nature of maritime affairs, where the owner of the ship was unknown, the arrest gave a remedy practically unlike that of foreign attachment. If, for example, a ship had been in collision, or had been repaired or supplied on the order of her master, her unknown owner might be liable. In proceeding against the ship he need not be named. In a sense, the arrest of the ship might be no more than security that judgment should be satisfied, yet the practical result of the proceedings was not wholly like that of foreign attachment. Thus, in *The Asunta* [1902] Prob. Div. 150, 154, Sir Francis Jeune said:

"There is undoubtedly an old practice in the admiralty court of great value, which enables the owners of a ship or cargo in any admiralty action to sue as such,—a proceeding which would have been regarded by the courts of common law with professional horror. But the court of admiralty allowed it for a very good reason,—because what they were really dealing with was one ship against another, and, so long as you had the names of the vessels, you had really all that was material."

For these reasons, and doubtless for others, the arrest of the ship in admiralty was deemed more and more a proceeding against the ship itself. The pleadings so describe it in many cases. Indeed, as is shown by the statement of Sir Francis Jeune just quoted, the personification of a ship in the law is to some extent almost an intellectual necessity. This personification has become more and more complete in the admiralty law of England and the United States. See *The Thomas P. Sheldon* (D. C.) 113 Fed. 779; *The S. L. Watson*, Id. As time went on, the allegation made by the libellant that he had no hope of redress other than by arrest of the ship was treated as merely formal, and then abandoned. See *Clerke's Praxis* (Ed. 1798) p. 37, note. The tendency, probably increasing through the latter part of the sixteenth century, to treat many suits in which the defendant's goods were attached as suits brought against the ship itself, was

greatly strengthened by the action of the courts of common law in granting prohibitions to the court of admiralty. These became more common. Sel. Pl. II, p. xv. More and more the courts of common law got the upper hand. They were more jealous of the jurisdiction of the admiralty over suits in which a personal judgment was sought than where the decree was solely against the ship. The former suits were deemed encroachments, pure and simple, upon the common-law jurisdiction. The latter, it was perceived, sometimes gave a remedy where the court of common law was impotent. See *Johnson v. Shippen*, 2 Ld. Raym. 982. In 1632 resolutions of agreement were settled before the privy council, and signed by all the judges. The third resolution was as follows:

"If a suit be in the court of admiralty for building, amending, saving or necessary victualling of a ship, against the ship itself and not against any party by name, but such as for his interest makes himself a party, no prohibition is to be granted though this be done within the realm." Godolphin, Adm. Jur. 157; Sel. Pl. II, p. 15.

Though these resolutions were repudiated some time afterwards by the courts of common law, there is reason to believe that they were observed for a time by both parties to the contest. The court of admiralty thus abandoned to a great extent its jurisdiction over suits in which a personal judgment was sought, while it was left in the enjoyment of undisturbed jurisdiction over suits against the ship itself, where no party defendant was named in the warrant of arrest or citation. Manifestly, a suit for building, repairs, or supplies, in which no defendant was named, could be brought only against the ship built, repaired, or supplied, and so the theory was confirmed that the building, repairing, or supplying a vessel was ground for suit in the admiralty against the vessel, without naming her supposed owner. This was established further by the statutes of the commonwealth of 1648, c. 112, which provided that "the court of admiralty shall have cognizance and jurisdiction against the ship or vessel with the tackle, apparel and furniture thereof, in all causes which concern the repairing, victualling, and furnishing provisions for the setting of such ships or vessels to sea." By this act the remedy was expressly limited to the vessel repaired or supplied. See *Watson v. Warner*, 2 Sid. 161. The statutes of the commonwealth were avoided by the restoration, and the jurisdiction of the court of admiralty was at once narrowed by prohibition, but, as we shall see, the admiralty long asserted its former rights, even if in vain.

It seems probable, therefore, that the lien or right to proceed against the vessel for its repairs or supplies which was recognized in English admiralty arose in part from the development of the procedure of the court. There is evidence that it arose also from a recognized principle of substantive admiralty law. It is true that Mr. Marsden observes (Sel. Pl. I, p. lxxii) that "scarcely a trace appears of the modern doctrine of arrest being founded upon a maritime lien." There is considerable trace of a doctrine that a maritime lien was deemed to arise upon a ship repaired or supplied. Thus, in *Draper v. The Fortune* (1580) Sel. Pl. II, 156, the sentence sets out that cables were "applied and converted to the necessary and beneficial use, reparation, and preservation of the said ship, and that by reason thereof from that time

the said ship was and remained hypothecated for the payment of the price of the same things and goods, and that she now remains hypothecated." See, also, *Draper v. The Black Greyhound* (1578) Id. 155; *Simondson v. Manelli* (1597) Id. 185. In *Draper v. The Busbye*, Id. p. lxx, the ship is said to be tacite hypothecata for necessaries. See *Page v. The Blessing of God*, Id. p. lxx. In precisely what proportions these two elements, (1) the development of procedure, and (2) the recognition of a tacit or implied hypothecation, operated to produce the theory of an implied lien as it existed in the middle of the seventeenth century, cannot be determined in our present state of knowledge. An examination of the records of the vice admiralty court of the provinces of Massachusetts Bay and Rhode Island in the first part of the eighteenth century shows a condition much like that just described. Libels in personam were common. Sometimes the suit is entitled against the vessel, and the decree is in personam. Sometimes the ship is libeled because the owner or master has failed to satisfy a personal decree. *Fitch v. Tudor*, Rec. I, 39. In suits between co-owners, the decree is often in rem, though the action is begun personally. In suits in rem for wages the decree may be that the owner pay, and that, if he does not, the vessel shall be sold. Where the vessel is attached, her owner, if accessible, is personally cited to appear. No case has been found in which the ship is libeled for a claim unconnected with her. Recognition of the liability of the ship, as distinguished from that of the owner or master, is common. Thus, in *Fitch v. Tudor*, the proponents "conceive the said ship is liable to answer and make good the same upon the said master's liability." In *Winthrop v. Sloop Africa*, I, 132, the decree recites supplies "wherewith the said sloop is affected and for which she is liable." See *Hodskins v. Sloop Argyle*, I, 114. In *Pemberton v. Ship Maunsell*, I, 62, the ship is said not to be liable for certain claims, but leave is given to push them against a former owner. It is to be noted that in the practice of these vice admiralty courts the libel was first exhibited and read. It might pray for a personal citation, or for an arrest of the res, or for both. The monition or citation followed. In some cases the master was cited by proclamation at the mainmast of the vessel. *Littleton v. James*, I, 10. See *The Clara*, R. I. Adm. Pap. 29. For the proceedings of the colonial court of admiralty in the seventeenth century, see *Records of the Court of Assistants, Colony of the Massachusetts Bay*, vol. I. As the same court, composed largely of laymen, administered both admiralty and common law, confusion between the two was natural. Thus a libel brought by the master of a vessel against the vessel and owner for wages and disbursements resulted in a personal decree against the owner and an execution in common form levied on the ship. *Skinner v. The Dove* (1675) p. 372. See, also, *Bromehall v. The John and Benjamin*, p. 373; *Gretson v. The Pink Expectation*, *Schinchinke, Owner*, pp. 178, 378; and generally *passim*.

The admiralty jurisprudence of England thus recognized a lien of some sort, or a right to proceed against the vessel, in favor of the materialman for repairs and supplies furnished to her; and this whether they were furnished at home or abroad, in case of exceptional necessity, or in the ordinary course of operations. The earlier cases show

no distinction between foreign and domestic repairs and supplies. Lord Stowell said in *The Zodiac*, 1 Hagg. Adm. 320:

"In most of those countries governed by the civil law, repairs and necessaries form a lien upon a ship herself. In our country the same doctrine had for a long time been held by the maritime courts; but after a long contest it was finally overthrown by the court of common law and by the highest judicature in the country, the house of lords, in the reign of Charles II."

See *The Alexander*, 1 Dod. 278.

Even in Lord Stowell's day, although the court of admiralty was prohibited from enforcing a lien upon a vessel in favor of a domestic materialman, yet, if the vessel had been sold for other sufficient causes, and the proceeds were in the registry of the admiralty court, that court was for a time allowed to enforce a lien upon these proceeds. See *The John*, 3 C. Rob. Adm. 288. This curious survival arose from the failure of the courts of common law to prohibit the enforcement of a lien upon the proceeds, while they strenuously prohibited the enforcement of a lien upon the vessel. By the admiralty law the lien existed in both cases. It is true, as has been said, that the court of admiralty did not distinguish greatly between a lien proper for supplies and a right to attach a ship by legal process and sell her to satisfy the bill for supplies furnished her. The latter right, though different in theory, yet answers much the same purpose as a lien, and is hardly distinguishable from it, unless a question of priority arises. The suit is regarded as brought against the vessel, not to collect the owner's debts, but to enforce payment of a debt for which the vessel itself is deemed liable. The right to proceed against the ship irrespective of its owner, to hold the ship liable for what were deemed the ship's debts, was in issue, rather than the precise order in which the ship's debts were to be paid. If the ship can thus be proceeded against, a lien of some sort is recognized, though its rank is left undetermined. The case put is not that of a suit brought on a personal liability which is enforced by an attachment of the owner's property on mesne process. The primary suit is against the ship, and it has come to pass that the ship cannot be proceeded against for a debt of her owner unconnected with her. "For the common course of proceedings in the admiralty in cases of this nature is by process to arrest the ship, and 'tis that which brings in the proprietors pro interesse suo, and then the libel follows." *Child v. Sands* (1693) Carth. 294. See *Greenway v. Barker* (1613) Godb. 260; *Watson v. Warner* (1659) 2 Sid. 161. The lien or similar right in the vessel given generally to a materialman by the English system of admiralty law was deemed to cover repairs and supplies wherever furnished. Thus Sir Leoline Jenkins says:

"But the greatest discouragement of all is that of materialmen; such as furnish tackle, furniture, or provisions for the repairing of ships or setting of them out to sea. When they are not paid at the time appointed, they arrest the ship, which will bring all the part owners to answer for it; but if, when they declare in the admiralty, a prohibition be granted, the remedy will be against the master alone, who, tho' he bespoke the materials, is commonly not worth the 20th part of the action. And these materialmen have often offer'd to make it demonstrable before his royal highness that if the ship shall be subject to their arrest without danger of a prohibition (because the contract was upon the land) an 100 sail of ships shall be furnished and set out with more ease and less time than 5 now can be, as the practice of pro-

hibiting hath lately been. For there is not any master but may command £1,000 worth of goods upon his ticket in a morning, when the materialmen do know that they may arrest a ship with effect in case he and his owners don't come and give each materialman such money or security as will content him. Whereas, if they be forced for their remedy to common law against the master and his part owner (who are most commonly persons unknown, and at a distance), they had better keep their wares in their shops than pursue so many upon such unequal terms." "But the greatest convenience of all will be the encouragement to materialmen. If they be but secure of their action against the ship, there is nothing in their warehouse but will be forthwith furnished upon the credit of the ship. And if we may believe men of experience, this will contribute more effectually than anything to his majesty's designs for the increase of shipping and the encouragement of navigation. And if the bill before your lordship will naturally produce these effects, as it certainly will, I need not enlarge any other conveniences." *Jenkins' Life*, vol. I, pp. lxxvi, lxxxiii, lxxxiv.

This argument plainly shows that a personal action to be brought in the court of admiralty against the shipowner was not then desired by the supporters of the admiralty jurisdiction, but only a suit in rem against the ship for both domestic and foreign furnishings. See *The Champion*, Fed. Cas. No. 2,583. It is true that in 1835 the judicial committee of the privy council in *The Neptune*, 3 Knapp, 94, 115, said that the maritime law of England had never given a lien for domestic supplies. To this statement it must be replied that a decision of the highest court makes law, but its opinion cannot change past events. The historical error thus made by the privy council has already been demonstrated, and will still further appear.

We have next to consider what were the limits imposed upon this enforcement of the lien for repairs and supplies by courts of common law. In studying the early reports of cases of prohibition, several things must be noted: First. The report was unofficial, and was often prepared with less care than that used at the present time. The report, therefore, is not always quite intelligible. Second. The fact that a prohibition was sought and obtained proves two things: (a) That the admiralty court claimed, and (b) that the common-law court denied, the jurisdiction of the admiralty in the case supposed. The granting of a prohibition proves the claim quite as thoroughly as it proves the denial. Third. The decided cases exhibit a conflict between two courts and two systems of law; a conflict which lasted for several centuries, and in which the court of common law was the stronger, and finally prevailed, while yet the court of admiralty never admitted itself to be in the wrong. In the course of the struggle several compromises were proposed, and the result finally reached had the nature of a compromise, though the admiralty obtained very little of its original claim. The decisions, therefore, are not altogether consistent with each other. The jurisdiction of the admiralty in case of supplies furnished in a domestic port was denied in *Leigh v. Burley* (1610) Owen, 122, but in *Tasker v. Gale* (1634) 1 Rolle, Abr. 533, it was said that, if a shipwright sues in the admiral's court for the fittings of the ship for navigation at sea, no prohibition lies. This case has often been quoted to show that the courts of common law recognize the right to sue in the admiralty under the conditions stated. Yet nothing is plainer than that the courts of common law generally denied the right. The explanation of the statement in *Tasker v. Gale* is prob-

ably to be found in the fact that the case was decided only two years after the compromise resolutions of 1632 had been entered into, and while they were yet deemed to be in force. By these resolutions the jurisdiction of the admiralty was recognized in libels for building and for domestic supplies, and the decision in *Tasker v. Gale* followed the resolutions. Again, it was admitted that suit could be brought in the admiralty upon a hypothecation of the ship made at sea. The longest debate between the common law and the admiralty concerned the right to sue in the admiralty upon a hypothecation made in a foreign country on land. In *Bridgeman's Case*, Hob. 11, Id. (1615) Moore, 918, a prohibition was granted against a suit in the admiralty to hold a ship for money borrowed at Seville by the master. The prohibition seems to have issued because the money was borrowed on land, and so the suit was deemed to be beyond the admiralty jurisdiction, inasmuch as that jurisdiction was limited by the statute of Richard II to matters arising upon the high seas. "The admiralty court hath no power over any case at land, for both by the nature of the court and by the statute it is only to meddle with things arising upon the high seas." It is true that in the opinion mention was also made of the right of the master to pledge the ship in case of necessity, but the chief justice recognized that the decision went altogether upon the want of jurisdiction of the admiralty court, and not upon substantive admiralty law. He said, "I am of opinion clearly that, if this case had been within the jurisdiction of the admiralty, that we should not prohibit them because they gave sentence against our law in this point of impawning, for it shall be presumed according to their law, or else to appeal." See *Jenkins' Life*, I, 83. So, in *Cradock's Case* (1610) 2 Brownl. & G. 37, "it was cited to be adjudged that, if a contract be made at Roan, in France, that shall not be tryed in the admiral court, for that it was made upon the land, and not upon the sea." See *Johnson v. Shippen*, 2 Ld. Raym. 982; *Thomlinson's Case*, 12 Coke, 104. In *Cossart v. Lawdley* (1688) 3 Mod. 244, a prohibition was issued in case of a hypothecation, and a suit was ordered to be brought at common law upon the necessity of borrowing; but, when a suit was brought against the original libellant under the statute of Richard II, Chief Justice Holt seems to have decided for the defendant, saying that there was no color for the prohibition, as the matter was triable only in the admiralty court, though the hypothecation was in a foreign land. *Corset v. Husely*, Comb. 135, Holt, 48. This construction of the statute of Richard II, which permitted the admiralty to take jurisdiction of a suit against a ship upon a bottomry bond made abroad and on land, became the established law. See *Lister v. Baxter* (1726) 2 Strange, 695; *Watkinson v. Bernardiston* (1726) 2 P. Wms. 367. That the right to sue in the admiralty for advances, repairs, and supplies depended altogether upon the territorial jurisdiction of the admiralty, and not upon substantive admiralty law, is further illustrated by *Godfrey's Case*, Latch. 11 (Temp. Jac. I), where it is said that, if the ship lies at anchor, wanting victuals, and sends to J. S. to bring victuals, then the contract is made on the ship, therefore upon the sea, and so the matter is triable in admiralty; otherwise if the contract is made on land, and the victuals are afterwards sent to the ship. Here the ownership and situation of

the vessel, the nature of the supplies, the necessity of victuals, and all concomitant acts are precisely the same, yet the right to libel the ship is made to depend wholly upon the technical locus contractus. See *Thomlinson's Case* (1605) 12 Rep. 104; *Cradock's Case* (1610) 2 Brownl. & G. 37. The case of *Tucker v. Cappes* (1625) 2 Rolle, 492, 497, illustrates the confusion into which the courts of common law sometimes fell concerning matters of admiralty and foreign law. The question did not concern a lien, but apparently a suit for demurrage. One judge observed incidentally, referring to the colony of Virginia, that the admiral's court has jurisdiction of acts done in all countries except England, because all other countries are governed by the civil law. See *Delabroche v. Barney* (1589) 3 Leon. 232; *Ball v. Trelawny* (1641) Cro. Car. 603. In *Watson v. Warner* (1659) 2 Sid. 161, it was stated that by the rules a person could be attached in the admiralty as well as the ship. In that case the court was governed by the statute of the commonwealth above referred to, and some rules may have been made thereunder of which no record can now be found; otherwise it would seem that the reporter must have misunderstood the case. In *Smith v. Tilly* (1665) 1 Keb. 708, after the restoration, and at a time when the statutes of the commonwealth were not in force, the court was divided concerning the granting of a prohibition in the matter of a libel against a ship for provisions and wages, "which hath been in these cases so constantly used, but in other cases it's against the parties. But per cur. this is but a device, and the parties may come in and be admitted pro interesse, as if the original process were against them. 1 Cr. 296 (the resolutions of 1632) is an anomalous collection, and by this course, if the butcher or baker sue or be sued for meat sold to the master, it should be in the admiralty, which would be inconvenient. But there not appearing any rule for prohib. adj." Page 712: "The court were divided *Hyde & Wyndham* against *Twisden & Keeling*, that this libel against a ship for provisions is as good as for mariners' wages; but by *Keeling* this is but by sufferance, because they are poor men and going to sea. Also *Wyndham* doubted that a ship may be pawned in England, but by *Keeling* clearly it cannot be pawned in England, but only by distress beyond sea." The case shows that the want of jurisdiction in the admiralty over a libel for domestic supplies was not yet completely settled. The resolutions of 1575 and 1632 and the statutes of the commonwealth had somewhat affected legal opinion. Moreover, the common-law judges, or at least their reporters, began to confound the question of jurisdiction with that of substantive law. In *Coomes v. Jenkinson* (1675) 3 Keb. 398, the jurisdiction of the admiralty under the conditions supposed was denied, and prior statements to the contrary were declared to be "exploded opinions." See *Merryweather v. Mountford* (1676) 3 Keb. 552; *Hoare v. Clement* (1684) 2 Show. 338, which cases show that the admiralty still claimed jurisdiction. That the right to sue in the admiralty depended, not upon substantive law, but upon the place where the contract was made, is still further illustrated by cases in which a foreign ship was repaired in England. Here the necessity of repair, the absence of the owner, and other circumstances were the same as those attending the repairs of an English ship abroad. Yet the court

of admiralty was deemed to be without jurisdiction. Thus, in *Justin v. Ballam* (1702) 1 Salk. 34, a foreign ship in distress purchased supplies at Ratcliffe upon the Thames. The ship was libeled in the admiralty, and in arguing the question of prohibition counsel for the libellant relied upon a case which sustained the jurisdiction of the court over a libel against an English ship hypothecated in Holland. The court of king's bench observed:

"By the maritime law the contract of the master implies an hypothecation, but by the common law it is not so, unless it be so expressly agreed. In the Case of Coster there was an express hypothecation, and that was in a place where hypothecations were allowed good. For that reason we allowed the jurisdiction of the admiralty in that case, for there was no remedy at common law; but in this case there is nothing but a mere common contract at land."

A prohibition was therefore issued. See *Benzen v. Jeffries* (1697) 1 Ld. Raym. 152. The *Henrich Bjorn*, 11 App. Cas. 270, 282. In defending the jurisdiction of the court of admiralty, Zouch observes:

"Some amongst us as take upon themselves to determine that to the jurisdiction of the admiralty of England no special or certain causes do belong. So the Lord Hobard in *Audley and Jenning's Case* affirms that their jurisdiction is not in respect of any certain cases, as the causes of Tithes and Testaments are in the Spiritual Courts, but only in respect of place; and no doubt but Sir Edward Cook and others, who talk so much of *altum mare*, are themselves perswaded and would perswade others to be of that opinion." Zouch, Adm. p. 28.

The language of the common-law courts, indeed, does not always distinguish between matters of jurisdiction and of substantive law. Thus Lord Mansfield said:

"Work done for a ship in England is supposed to be on the personal credit of the employer. In foreign parts the captain may hypothecate the ship." *Wilkins v. Carmichael*, 1 Doug. 101.

And Lord Hardwicke said:

"If at sea, where no treaty or contract can be made with the owner, the master employs any person to do work on the ship, or to new rig or repair the same, this, for necessity and encouragement of trade, is a lien upon the ship, and in such case the master, by the maritime law, is allowed to hypothecate the ship." 2 P. Wms. 367. See *Ex parte Shank*, 1 Atk. 234.

Very likely Lord Hardwicke meant no more by this expression than to say that the master abroad might hypothecate the vessel by bottomry. With all respect for these great judges, it must be said frankly that their dicta, if taken literally, represent neither the old admiralty law of England nor the common law, but merely the resultant of the two as worked out through a conflict of territorial jurisdiction. The admiralty law gave a lien upon the ship whether the work was done in England or not. The common law gave no lien upon the ship whether the work was done in England or not. See *Buxton v. Snee*, 1 Ves. Sr. 154; *Menetone v. Gibbons*, 3 Term R. 267. By the courts of common law, as has been said, the court of admiralty was at last allowed jurisdiction of a suit on bottomry bond made in the course of a voyage, whether executed on land or at sea. Lord Kenyon observed that the practice had been settled since the days of Lord Raymond. "Then, if the admiralty has jurisdiction over the subject-matter, to say that it is necessary for the parties to go upon the sea to execute the in-

strument borders upon absurdity." *Id.* 269. Mr. Justice Buller further observed, "The question whether the court of admiralty has or has not jurisdiction depends on the subject-matter." *Id.* These statements just quoted illustrate the confusion, before referred to, of jurisdiction and substantive law, and they directly contradict the statute of Richard II, and the well understood and established practice of the courts of common law in preceding centuries. The jurisdiction of the English court of admiralty, as declared by the courts of common law, depended generally, as Zouch says, not upon the subject-matter, but upon the locality. The jurisdiction of the admiralty over bottomry bonds made in a foreign land was an exception introduced for convenience, like that which admitted suits for seamen's wages. From early times, indeed, the courts of common law permitted seamen to sue in the admiralty. Later they decided that a master could not sue there, though the court of admiralty was ready to take jurisdiction. The distinction depended, not upon any difference in the substantive law of the admiralty, but merely upon the fact that the courts of common law had, as a matter of convenience and mercy (*Abb. Shipp.* [7th Am. Ed.] 820, 830; *Ewer v. Jones*, 6 Mod. 25; *The Mariners' Case*, 8 Mod. 379), permitted the jurisdiction of the court of admiralty in one case, while denying it in the other. The court of admiralty then was permitted by the courts of common law to exercise (1) jurisdiction of matters arising upon the high seas (this jurisdiction never having been denied), and (2) jurisdiction of suits for seamen's wages and of suits upon bottomry bonds made in foreign countries (this jurisdiction being exceptional and allowed only for the sake of convenience). Further exceptions must be created by statute. Saving for manifest exceptions, the jurisdiction was made to depend, not upon subject-matter, but upon locality.

After the attempt had failed to get relief in the admiralty, and to hold the ship itself for repairs and supplies, the materialmen had to resort to courts of common law, and there to bring suit against the owners. The right of a materialman to sue the owner on a contract entered into by the master depended upon the law of agency. If the master, as agent, had authority to bind his principal, and in making the contract acted within the scope of his authority, the owner was bound; not otherwise. Maritime law and custom were properly resorted to in order to determine the scope of the master's authority. "*Eyre, J.*, held there was no difference between a land carrier and a water carrier, and that the master of a ship was no more than a servant to the owners in the eye of the law, and that the power he has of hypothecation, etc., is by the civil law." *Boson v. Sandford*, 2 Salk. 440. At first it seems that the authority of the master was presumed. "It was held that prima facie the repairer of a ship has his election to sue the master who employs him or the owners, but, if he undertakes it on a special promise from either, the other is discharged." *Garnham v. Bennett*, 2 Strange, 816. Later it was said that, if the owner was absent, the master could bind him, but, if he was present, the contract bound only the master. "Under the general authority which the master of a ship has, he may make contracts and do all things necessary for the due and proper

prosecution of the voyage in which the ship is engaged. But this authority does not usually extend to cases where the owner can himself personally interfere, as in the home port, or in a port in which he has beforehand appointed an agent who can personally interfere to do the thing required. Therefore, if the owner or his general agent be at the port, or so near it as to be reasonably expected to interfere personally, the master cannot, unless specially authorized, or unless there be some usual custom of trade warranting it, pledge the owner's credit at all, but must leave it to him or to his agent to do what is necessary. But, if the vessel be in a foreign port, where the owner has no agent, or if in an English port, but at a distance from the owner's residence, and provisions and other things require to be provided promptly, then the occasion authorizes the master to pledge the credit of the owner." *Arthur v. Barton*, 6 Mees. & W. 138, 143. And, if the port of repairs was not far distant from the owner's port, the jury was to determine if the supplies were obtained for the necessary use of the vessel upon credit given to the owner; i. e., if the master, in pledging the owner's credit, was acting within the scope of his agency. The nearness of the owner was an element in determining if the purchase of supplies without consulting him was reasonably necessary. In other words, the presence or absence of the owner was a circumstance bearing upon the authority of the master to bind him. See *Edwards v. Havill*, 14 C. B. 107; *Robinson v. Lyall*, 7 Price, 592; *Beldon v. Campbell*, 6 Exch. 886; *Johns v. Simons*, 2 Q. B. 425; *Webster v. Seekamp*, 4 Barn. & Ald. 352; *Cary v. White*, 5 Brown, Parl. Cas. 325.

The liability of the owner of a vessel in contract for the acts of his authorized agent is a thing quite different from a lien arising from the act of repairing or of supplying. This appears from the cases in which the legal owner of a vessel was held not liable for the acts of the master duly appointed, upon the ground that, notwithstanding the legal ownership, the master was not his agent. Thus, where the vessel was under a charter which provided that the charterer should repair, the owner was held not bound, though the materialman knew nothing of the charter. *Reeve v. Davis*, 1 Adol. & E. 312; *Frazer v. Marsh*, 13 East, 238. Although these cases have no direct bearing upon the lien of the materialman, yet in the diminished state of the English admiralty jurisdiction, which prevented an action directly against the vessel, the lien and the owner's liability were confused. Thus, in *Rich v. Coe*, 2 Cowp. 636, 639, Lord Mansfield said: "Whoever supplies a ship with necessaries, has a treble security: (1) The person of the master; (2) the specific ship; (3) the personal security of the owners, whether they know of the supply or not." And see *Farmer v. Davies*, 1 Term R. 103; *Reeve v. Davis*, 1 Adol. & E. 312. It is possible that the theory of a right to proceed against the ship was connected with the theory, sometimes discussed, that the master, though the agent of the owners, could not bind them beyond the value of the ship. See *Yates v. Hall*, 1 Term R. 73, especially the opinion of Mr. Justice Buller. Probably the latter theory arose from a confusion between the general maritime law and the common law of agency. Certainly it is foreign in the latter, and it leads

naturally to a right of some sort to proceed against the ship. The authority of Lord Mansfield's great name, and the confusion just noted, caused his dictum in *Rich v. Coe*, notwithstanding its incorrectness, and its contradiction of his own statement in *Wilkins v. Carmichael* to be questioned at first, rather than denied. *Westerdell v. Dale*, 7 Term R. 306; *Jackson v. Vernon*, 1 H. Bl. 114. See, also, *The Ship Enterprise*, Hopk. Judgm. 171. It has been shown that this dictum was, as to proposition 2, in complete contradiction to the law of England as laid down in all cases except in those in which the court of admiralty successfully evaded the prohibitions of the courts of common law. It is to be noticed that even Lord Mansfield made no distinction between foreign and domestic vessels, and that the vessel of which he happened to be speaking was almost certainly domestic. It will hereafter appear that the decisions in the suits against the owner just referred to were sometimes misapplied by American courts in the discussion of suits against the vessel.

The history of the law of Scotland appears best from the briefs submitted to the House of Lords in *Wood v. Hamilton*, 3 Paton, 148, cited in *Maclachlan, Merch. Shipp.* (3d Ed.) 68; "Appeal Cases in the House of Lords (1786-1789)" at end of volume, in *Social Law Library*. The brief for the appellants in support of the lien for domestic repairs is signed by T. Erskine (Lord Erskine) and W. Grant (Sir William Grant); that for the respondents by Ilay Campbell (afterwards lord president of the court of session) and Alexander Wight. The proceeding was to establish a lien upon a vessel for repairs furnished in her home port. The lord ordinary sustained the lien. On appeal the court of session sought the opinion of English counsel upon the law and practice of England (for what reason does not appear). The English counsel replied that a materialman had no lien, founding his opinion entirely upon cases in the common-law courts. The court of session reversed the decision of the lord ordinary. Upon a first rehearing, sought by the counsel for the materialmen, the court of session reversed its first decision, and affirmed that of the lord ordinary. Upon a second rehearing the same court went back to its first decision, and reversed the lord ordinary. Upon a third rehearing the court adhered to its disallowance of the lien. *Mor. Dec. 6269*. The elaborate arguments of counsel on both sides are interesting. It was made to appear that the admiralty court of Scotland had long entertained jurisdiction of suits against a ship for repairs and supplies both foreign and domestic. Many unreported cases in the court of admiralty were produced to establish this fact. The practice had been sustained by the court of session in *Watson v. Arbuckle* (1711) *Mor. Dec. 6262*, and in *Rope-Work Co. v. Crosses* (1761) *Id. 6268*. Otherwise where the ship had not been launched. *Maxwell v. Wardroper*, *Id. 6266*. This appears to have been the common understanding. To meet this argument, the respondents were driven to urge "that the practice of the admiralty court in the matter appeared to have been a series of errors from first to last." There was some discussion regarding the continental law. The appellants asserted, as was quite true, that it generally gave a lien or right to proceed against the ship for domestic as well as for foreign

repairs. This was somewhat disputed by the appellees, in spite of the appellants' reference to the *Ordonnance de la Marine*. The house of lords confirmed the interlocutor of the court of session. There can be little doubt that the final decision was based largely upon a wish to harmonize the English and Scotch law upon the subject. See *Currie v. McKnight* [1897] App. Cas. 97. It was the first case that has been discovered in which, without written instrument, a vessel was held not bound for domestic repairs when it would admittedly have been bound for foreign repairs. The English law was still very different from the Scotch, for in England no lien (save by express hypothecation) was recognized for repairs, either foreign or domestic.

It has hitherto been shown that at the time of the American Revolution the English court of admiralty was permitted to exercise jurisdiction in favor of the materialman only in two cases: (1) Where there was a bottomry bond executed at sea or abroad (see *The Atlas*, 2 Hagg. Adm. 49); and (2) where the ship had been sold for some reason otherwise sufficient, and the proceeds were in the registry of the admiralty, in which case the materialman was for a time allowed to assert a lien on the proceeds, whether the materials were furnished in a home or in a foreign port. See *Waring v. Clarke*, 5 How. 441, 452, 12 L. Ed. 226. No distinction between foreign and domestic repairs was recognized until 1835. This limitation upon the admiralty jurisdiction resulted, not from any interpretation of the general maritime law by the court of admiralty, but merely from the prohibitions issued by the courts of common law, which restrained the court of admiralty from exercising in any other cases that general jurisdiction which the admiralty had claimed long and vigorously. The admiralty court claimed jurisdiction of all actions in rem (and originally of actions in personam as well) in all cases where supplies had been furnished a vessel, either in a home or in a foreign port, both where there was an express hypothecation by bottomry or otherwise and where there was no express hypothecation whatsoever. If, for example, a party brought suit in the admiralty court against a vessel for supplies furnished in the home port, the court gave him a remedy in theory, and probably in practice, unless and until it was prohibited from proceeding further by a court of common law. See *The General Burnside* (C. C.) 3 Fed. 228. In the seventeenth century the remedy was often effective. The jurisdiction which the English admiralty court exercised somewhat furtively, and vainly claimed where it was denied, the Scotch admiralty court then exercised fully. But after the decision of *Wood v. Hamilton* the substantive admiralty law of Scotland was declared to be different from the substantive admiralty law of England, though the available remedies of the materialman in the two countries were much the same. In England the domestic materialman had on his side the substantive admiralty law, but failed by the defective jurisdiction of the admiralty court. In Scotland the court was left with sufficient jurisdiction, but the substantive law was changed by *Wood v. Hamilton*.

From the admiralty courts of Great Britain we pass to those of the American colonies. It has been supposed that these exercised a ju-

risdiction much more extended than those of the mother country. Thus, in *De Lovio v. Boit*, 2 Gall. 398, 470, Fed. Cas. No. 3,776, Mr. Justice Story says that:

"The commissions of the crown gave the [colonial admiralty] courts which were established a most ample jurisdiction over all maritime contracts, and over torts and injuries, as well in ports as upon the high seas. And acts of parliament enlarged, or rather recognized, this jurisdiction by giving or confirming cognizance of all seizures for contraventions of the revenue laws. Tested, therefore, by this exposition, the admiralty jurisdiction of the United States would be as large as its most strenuous advocates ever contended for."

In support of this proposition, Mr. Justice Story cited the form of commission used in New Hampshire in 1731. See *Waring v. Clarke*, 5 How. 441, 454, 12 L. Ed. 226. But it must be remembered that neither the crown nor the courts of admiralty acquiesced in the construction given to those statutes by virtue of which the English courts of common law prohibited most of the admiralty jurisdiction. The fact that a royal charter reserved admiralty rights, or that a royal commission purported to give them, does not prove that those rights were exercised freely, and acquiesced in by the courts of common law. Thus Mr. Justice Woodbury said in his dissenting opinion in *Waring v. Clarke*, 5 How. 441, 477, 12 L. Ed. 226:

"These commissions, in the largest view, only indicated what might be done, not what was actually afterwards done under them. In the next place, all must see, on reflection, that a commission issued by the king could not repeal or alter the established laws of the land." "But besides these conflicting features in different parts of them, the commissions of vice admirals here seem, in most respects, copies of mere forms of ancient date in England."

See *New Jersey Steam Nav. Co. v. Merchants' Bank of Boston*, 6 How. 344, 422, 12 L. Ed. 465; *The Apollo*, 1 Hagg. Adm. 306, 312.

The decision in *Waring v. Clarke* is now the long-settled and thoroughly established law of the United States, and the dissenting objection of Mr. Justice Woodbury is quite unavailing, but his historical criticism of the scanty basis of Judge Story's argument is not shaken. Mr. Justice Woodbury went on to observe on page 479, 5 How., and page 226, 12 L. Ed.:

"In connection with this, all the admiralty reports we have of cases before the Revolution, and of cases between 1776 and 1789, seem to corroborate the same view, and are worth more to show the actual jurisdiction here than hundreds of old commissions containing obsolete powers never enforced. There is a manuscript volume of Auchmuty's decisions made in the vice admiralty court of Massachusetts about 1740. See *Curt. Merch. Seam.* 348, note. It will be difficult to find in them, even in one colony, much more in the thirteen, clear evidence of any change here, before the Revolution, in respect to the law concerning the locality of torts."

But here it must be observed, upon the other side, that the basis of Judge Woodbury's statement is itself somewhat narrow. There are several manuscript volumes, instead of the one he referred to, and they cover a large part of the proceedings of the vice admiralty court of Massachusetts between 1716 and 1776. Regarding the jurisdiction actually exercised they sustain pretty completely Judge Story's contention, though it seems he never read them. See *Insurance Co. v. Dunham*, 11 Wall. 10, 20 L. Ed. 90; 21 Wall. 601, 22

L. Ed. 654. They contain libels in personam for the wages of the master, and libels in rem for his wages and his disbursements (*Fletcher v. La Taile*, vol. I, p. 17; *Allen v. Johonnot*, I, 26; *Pulsifer v. Walley*, I, 48; *Stanley v. The Adventure*, I, 105; *Hodskins v. Sloop Argyle*, I, 114); libels in personam for freight due under a charter party; libels in rem for the survey and sale of a vessel cast away on the coast of Massachusetts (one of these cases is printed by Mr. Curtis at page 378,—*Oliver*, Petitioner); a libel in personam for failure to prosecute a voyage, brought by the owner of the cargo (*Fitch v. Tudor*, I, 39); libels in rem for supplies furnished a vessel, the vessel probably being foreign, and the claim being really upon the proceeds, rather than upon the vessel itself, no bottomry being alleged (*Hill v. Ship Elizabeth*, I, 43 et seq.; *Winthrop v. Sloop Africa*, I, 132). These cases are directly opposed to *Justin v. Balam*. There are many possessory cases: A libel in personam for failure to deliver up the effects of a passenger (*Conner v. Manachy*, I, 51); a libel in personam for freight (*Logan v. Bodkin*, I, 59); a libel in personam for expenses in fitting out the vessel (*Pemberton v. Goffe*, I, 63); libels in personam, for damage done by improper stowage (*Franklin v. Browne*, I, 66); libels by part owners of vessels to compel other part owners to agree to a voyage or to fit out the vessel, the decree sought being an enforced sale or purchase by a dissenting owner (*Nelson v. James*, I, 102; see *Dimmock v. Chandler*, *Fitzg.* 197); a libel in rem for rigging and other supplies (*Winthrop v. The Africa*, I, 132); libels in rem for wharfage and advances (*Gallop v. The Willing Mind*, I, 180; *Gerrish v. Ship Sarah*, I, 123); a libel in rem by the builder of the vessel for a part of its price (*Alfrey v. Snow Charming Molly*, II, 86); libels in rem for work done on a vessel (*Wakefield v. Cloud*, II, 96; *Gibbs v. The Christiana*, II, 110). The records of the vice admiralty court of the province of Rhode Island are to the same effect. In *Moffatt v. The Mermaid*, formerly called *The Peggy*, decided December 14, 1752, a proceeding to compel a co-owner either to pay his share of the cost of fitting out the vessel, or to sell the share at an appraised value, the case was heard against an objection to the jurisdiction. See *Averill v. Blackstock*, 1750; *Belknap v. Freeman*, 1752. *Freeman v. Craine*, 1747, and *Chadwick v. Clark*, 1751, were suits in personam for pilotage. *Oliver v. The Industry*, 1744, was a suit by the master for wages and advances, combined with a suit by the crew for wages. These cases give considerable support to the argument of Mr. Justice Story, and meet pretty completely that of Mr. Justice Woodbury; but there are other considerations which must yet be weighed. These cases show what the court of admiralty believed itself competent to do, but not improbably the contemporary records of the English admiralty court would show a somewhat similar state of affairs. In many or most of the cases above cited the parties respondent may have admitted the jurisdiction; that is to say, they may have failed to seek writs of prohibition. There is ample evidence that the courts of common law in the provinces of Massachusetts and Rhode Island were issuing at the same time prohibitions to the court of admiralty. To determine precisely the rules which governed the issu-

ance of these writs would require a more thorough investigation of the records of the provincial courts of common law than I have had time to make. See *Scollay v. Dunn*, Quincy, 74; *Bardin v. Lambert*, Rec. (1730-1733) 135; *Patten v. Stacy*, Id. (1716) p. 143; *Shaw v. Bethune*, Id. (1725-1730) 182; *Perkins v. Wylie*, Id. 338. The case of *Potter v. The Brigantine Greyhound*, decided by the vice admiralty court of Rhode Island in 1747, was a libel in rem for cash advances, labor performed, and necessities furnished in Newport on the order of the owners of the vessel. It seems that the owners resided at Bristol. The vessel was arrested, and the owners pleaded to the jurisdiction. The plea (so styled) was overruled. The owners obtained a writ of prohibition. After several adjournments, the admiralty court still proceeded with the case, probably because the proceedings in prohibition had been dropped on account of an agreement to refer to arbitration. This agreement failing, the libellant proceeded in admiralty, and was permitted to do so in spite of the claimant's objections. A second prohibition followed, and the admiralty proceedings were ended by an agreement for a retraxit. This case illustrates the jurisdiction over maritime liens which the vice admiralty court sought to exercise, and it shows also that an assumption of jurisdiction by a court of admiralty is not the same thing as a recognition of that jurisdiction by the more potent court of common law. The most that can be said of the colonial admiralty records is this: They show (1) that these courts exercised the jurisdiction which the English court of admiralty claimed, and which that court may have exercised, in many cases; (2) that this exercise of jurisdiction was not altogether acquiesced in by the courts of common law; but (3) that, as a result, the colonial admiralty courts probably did exercise in fact a somewhat broader jurisdiction than did the corresponding English court, though there was between the two no admitted difference of law. By virtue of an act of parliament it seems that the colonial courts of admiralty exercised in some matters connected with the customs a jurisdiction denied to the English court of admiralty (see *U. S. v. Bevans*, 3 Wheat. 336, 383, 4 L. Ed. 404); but no act of parliament, so far as known, extended their jurisdiction over maritime liens. The act of 15 Rich. II, c. 3, was taken to be the law of the land in Massachusetts and in Rhode Island, as in England, and there is no evidence that the colonial courts of common law, when appealed to, gave to it a construction less extended than did similar courts of England. See, also, *Brayton v. Almy*, decided by the Rhode Island superior court of judicature March 22, 1733. The prohibition then asked for was denied, indeed, but the statute of Richard II seems to have been recognized as having full application. See *Waring v. Clarke*, 5 How. 441, 461, 12 L. Ed. 226; *Freeman v. Belknap*, R. I. Super. Ct. Jud. March, 1754.

Between the Declaration of Independence and the adoption of the federal constitution there exist two or three reported cases. In *Clinton v. The Hannah* (1781) Bee, 419, Fed. Cas. No. 2,898, the court, in dealing with the alleged lien of a shipwright for building a vessel, recognized the English rule, and followed professedly the decisions of the English courts of common law. In *Shrewsbury v.*

The Two Friends, Bee, 433, Fed. Cas. No. 12,819, decided in 1786, Judge Drayton said:

"And herein I distinguish thus: Where a vessel is lying in port, and the owner is there present, all matters and contracts relative to her must be supposed to be entered into by him on shore, and consequently to be *infra corpus comitatus*; and redress and satisfaction in case of any dispute on the occasion must be sought in the courts of common law. But where a vessel is on a voyage, and by stress of weather or other accident puts into a port, the occasion happening at sea, and on her arrival in port no owner being present to whose personal credit recourse may be had for necessaries, the master, *ex necessitate rei*, has a right to procure them on the security of the vessel; and to obtain payment on that security that is the proper and only court to apply to. This distinction is plainly laid down and taken notice of in all the cases where this matter has been agitated."

The learned judge quoted in support of his argument almost altogether from cases in the English courts of common law. It seems that he believed that the reason why a libel in rem could be maintained in the admiralty for supplies furnished a vessel in a foreign port was that the jurisdiction of the court of admiralty attached to a contract for supplies there made, while such a suit could not be maintained for domestic supplies, because the jurisdiction of the court of admiralty did not attach to a contract made in a domestic port. He did not suppose that the substantive law of the admiralty gave a lien in one case more than in the other. He believed himself to be following, not the general maritime law, but the limitations imposed upon the admiralty jurisdiction by the English courts of common law. He therefore refused to permit the domestic ship carpenter to recover. His reasoning, indeed, might perhaps have permitted a recovery for supplies furnished in a foreign port, even where no bottomry bond had been given. If he would really have permitted this, he was prepared to go further than the English admiralty courts had been allowed to go, but at the most this conclusion of his was a doubtful *obiter dictum*. His language, like that of contemporary English courts, shows the beginning of that confusion between jurisdiction and substantive law which has so much affected the later history of the lien.

When the federal district courts were established as courts of admiralty, they found their situation greatly different from that of all previous admiralty courts in countries governed by the common law. (Some colonial courts had both admiralty and common-law jurisdiction, and some state courts had admiralty jurisdiction between 1776 and 1789, but the exceptions are insignificant.) See *The Lottawanna*, 21 Wall. 559, 580, 22 L. Ed. 654. Thereafter prohibitions became rare, though still permitted by statute. See Rev. St. § 688 [U. S. Comp. St. 1901, p. 565]; *Ex parte Gordon*, 104 U. S. 515, 26 L. Ed. 814; *In re Fassett*, 142 U. S. 479, 12 St. Ct. 295, 35 L. Ed. 1087; *Ex parte Phenix Ins. Co.*, 118 U. S. 610, 7 Sup. Ct. 25, 30 L. Ed. 274. The court which could prohibit and the court of appeal were the same. The same court of admiralty determined the jurisdiction and applied the substantive law. True, there was an appeal both as to jurisdiction and substantive law, but the appeal

was to a higher court of admiralty. On the other hand, the federal judges who sat in admiralty were no mere civilians. They were generally common lawyers, who, then as now, added to their legal store such knowledge of civil and general maritime law as their duties gave them time to acquire. Their acquaintance with the civil law, not their ignorance of it, is surprising; but their fundamental training had its results. In *North v. The Eagle*, Bee, 78, Fed. Cas. No. 10,309, decided in 1795, Judge Bee, the successor of Judge Drayton, sustained a libel for supplies furnished in a foreign port. The decision was rested upon the erroneous dictum of Lord Mansfield in *Rich v. Coe*, 2 Cowp. 636, 639, above quoted. That dictum suggested no difference between a domestic and a foreign port. Notwithstanding its unsafe foundation, the decision in *North v. The Eagle* is authority that a suit in rem can be maintained against a vessel without hypothecation. The suggestion that this remedy was limited to the case of supplies furnished in a foreign port was not reasoned out, and was apparently made to depend upon the limits of the admiralty jurisdiction, and not upon the substance of the admiralty law. In *Boreal v. The Golden Rose*, Bee, 131, Fed. Cas. No. 1,658, decided in 1798, a merchant who had supplied a captain with money in a foreign port brought suit against the vessel. The learned judge began his opinion by stating that all the cases quoted as bearing upon the question "were determined in courts of common law, but upon the principles of the civil law,"—a statement so unintelligible as to raise a doubt if the printer did not play him false. He next referred to the dictum in *Rich v. Coe*, above cited, without noticing that no distinction was there made between foreign and domestic repairs, and then said that there was no lien unless with possession or by "hypothecation duly made,"—a statement in flat contradiction to Lord Mansfield's dictum. As the learned judge found that the vessel had not been "hypothecated by deed or implication" he dismissed the libel. Notwithstanding his suggestion of an implied hypothecation, he seems to have treated the case mainly as one of bottomry. This appears further from his reference to *The Emperor*, Hopk. Judgm. 163, 170. In *Pritchard v. The Lady Horatio*, Bee, 167, Fed. Cas. No. 11,438, decided in 1800, the same judge dismissed for want of jurisdiction a libel brought against a foreign vessel for repairs, and in his opinion seems to have somewhat confused a want of jurisdiction, the presence of an agent of the owner, the fact that the vessel was unladen, and that no necessity for giving credit existed. See *O'Hara v. The Mary*, Bee, 100, Fed. Cas. No. 10,467. These cases show that the confusion then existing in the minds of some English common-law judges was reflected in the minds of American judges who had been called from the study and practice of common law to sit in a court of admiralty. In *Woodruff v. The Levi Dearborn*, Fed. Cas. No. 17,987, decided in the district court of Georgia in 1811, a libel in rem was dismissed for want of jurisdiction where the materials had been furnished at the instance of the owner of a vessel which was not then upon a voyage. The contract was treated as outside the jurisdiction of the admiralty, the judge professedly following the case of *Shrewsbury v. Two Friends*. In the same case on appeal,

Fed. Cas. No. 17,988, Mr. Justice Johnson affirmed the judgment of the court below, and said:

"The argument in support of this libel has proceeded on the ground that the admiralty law of the United States is the civil law of the Roman government. But the civil law has undergone many changes and modifications, which we are not bound to trace. The admiralty law of Great Britain is the admiralty law here. The lien on vessels for materialmen and shipwrights exists only in a foreign port. Where the owner is present and resident, the common-law principle must govern. In such case no lien on the vessel is created. In the case of an owner, who, though present, when the work and materials are furnished, is transient and nonresident, I am disposed to think otherwise, and that in such case the lien attaches."

Doubtless the learned judge thus extended by implication the jurisdiction of the admiralty court beyond that permitted in England, though he did not perceive that he had done so. Also he appears somewhat to have lost sight of the difference between jurisdiction and substantive law. He speaks of the "common-law principle" governing in one case and not in another. Probably, however, he meant no more than that the admiralty court had jurisdiction in one case and had no jurisdiction in the other. These decisions and their language tended, however, to bring about the further confusion which will presently appear. In *Gardner v. The New Jersey*, 1 Pet. Adm. 223, Fed. Cas. No. 5,233, the court took jurisdiction of a libel in rem by a master for supplies, saying:

"Claims of materialmen for supplies afforded to a ship are within the jurisdiction of the admiralty, and suable there, in England, as well as in other states. Pilotage is a necessary expenditure on a voyage. If a master pays demands for these claims, he represents the claimants, and the lien continues on the moneys produced by the sale of the ship. As to pilotage, the master is bound by the Laws of Oleron, and other maritime laws, to pay it, for the safety of the ship and goods. In England a shipwright may sue in the admiralty for building a ship for navigation on the sea, and for repairing a ship."

The last remark shows the danger of relying upon two or three cases only, where the mass of reported decisions is great, and especially where the reports are early and imperfect. If there was a point of law then well settled in England, that point was the want of jurisdiction in a court of admiralty over a libel by a shipwright to recover for his services in building a vessel. Throughout his opinion in *Gardner v. The New Jersey* the learned judge plainly believed himself to be regarding the limits of English admiralty jurisdiction, however mistaken his notions of those limits may have been. On the other hand, in *Stevens v. The Sandwich*, 1 Pet. Adm. 233, Fed. Cas. No. 13,409, decided in 1801 in the district court of Maryland, Judge Winchester held that the courts of admiralty created by the constitution were not limited in their jurisdiction by the prohibitions issued by the English courts of common law, and that they could take cognizance of contracts and debts for building and repairing ships. He therefore sustained a libel in rem for repairs, apparently made in the home port. This was the first, and for some time the only, reported case, which suggested that the jurisdiction of the American admiralty courts was different from that of the English. According to the late Judge John Lowell, the unreported practice of the admiralty court in this district agreed with *Stevens v. The Sandwich*. See *The George*

T. Kemp, 2 Low. 477, 481, Fed. Cas. No. 5,341. This practice may have arisen from the broad jurisdiction assumed by the colonial court of vice admiralty in Massachusetts. In *The Jerusalem*, 2 Gall. 345, 348, Fed. Cas. No. 7,294, Mr. Justice Story said:

"The admiralty has always rightfully possessed jurisdiction over all maritime contracts; and the decisions of the courts of common law, prohibiting its exercise, are neither consistent in themselves nor reconcilable with principle." "It will be recollected that this is a foreign ship, and that by the general maritime law every contract of the master for repairs and supplies imports an hypothecation. It has been supposed that the rule of the common law is different. But it has never yet been extended to cases of repairs of foreign ships, or of ships in foreign ports. I hold, therefore, that the contract for repairs in this case, being of a foreign ship, is to be governed by the maritime law, and created a lien. Whether, in case of a domestic ship, materialmen have a lien for supplies and repairs furnished at the port where the owner resided, I give no opinion. There are great authorities on both sides of the question, though upon principle, independent of common-law authorities, it does not seem to me that there is much room for doubt. Be this as it may, it cannot affect the jurisdiction of the admiralty in such cases, for that stands altogether independent of the doctrine of liens, and may be enforced as well by process in personam as in rem." Pages 349, 350, 2 Gall., and Fed. Cas. No. 7,294.

From these quotations it will be seen that Mr. Justice Story, while undoubtedly accepting the general jurisdiction of the admiralty in case of maritime contracts, yet doubted whether a court of admiralty should apply the general maritime law or the common law to the case of domestic repairs. With all his great learning, he seems to have forgotten that no English admiralty court ordinarily applied the common law to any question before it, and that no English court of common law ever dreamed of making it do so. In other words, even he confused jurisdiction and substantive law, as it has been shown that other judges were doing elsewhere at about the same time. In *De Lovio v. Boit*, 2 Gall. 398, Fed. Cas. No. 3,776, decided in 1815 in an opinion which is now classic, Mr. Justice Story decided that the admiralty court had jurisdiction, concurrently with the courts of common law, over maritime contracts, and that the federal courts of admiralty were not confined by the English limitations. The law then stood thus: Several circuit and district courts had decided that the American admiralty jurisdiction was the same as the English, although, in determining that jurisdiction, they had sometimes failed to observe correctly what the English jurisdiction actually was, and so had taken jurisdiction of suits in rem against a vessel for supplies furnished in a foreign port without express hypothecation,—a matter of which the English court of admiralty was not permitted to take jurisdiction. Other circuit and district courts had held that the federal courts of admiralty had a jurisdiction similar to that which the English admiralty courts had claimed, and one district court had applied this jurisdiction to the case of domestic supplies, permitting therefor a libel in rem. For a long time the conflict was left unsettled by the supreme court. In *The Charles Carter*, 4 Cranch, 328, 2 L. Ed. 636, the court took jurisdiction without question of a libel on a bottomry bond given by the owner in the home port, though it denied that, under the circumstances of the case, a lien existed. This was an

extension, probably unrecognized, of the English admiralty jurisdiction. In *Martin v. Hunter's Lessee*, 1 Wheat. 304, 335, 4 L. Ed. 97, Chief Justice Marshall observed that "the admiralty jurisdiction embraces all questions of prize and salvage, in the correct adjudication of which foreign nations are deeply interested. It embraces also maritime torts, contracts, and offenses, in which the principles of the law and comity of nations often form an essential inquiry." Thus he implied that the constitution (article 3, § 2), by extending the judicial power of the United States to all cases of admiralty and maritime jurisdiction, and the judiciary act of 1789, by giving to the district court jurisdiction "of all civil causes of admiralty and maritime jurisdiction," conferred upon the district court a jurisdiction in admiralty more extensive than that allowed by the courts of common law to the English admiralty court. The constitution and the judiciary act were thus made to repeal or avoid the statute of Richard II. The dictum just quoted seems to have long passed unnoticed. See *U. S. v. Bevans*, 3 Wheat. 336, 388, 4 L. Ed. 404, and the arguments of counsel; *U. S. v. Wiltberger*, 5 Wheat. 76, 106, note, 113, 5 L. Ed. 37; *Waring v. Clarke*, 5 How. 441, 457, 464, 12 L. Ed. 226. In *The Aurora*, 1 Wheat. 96, 4 L. Ed. 45, the court refused to enforce by a libel in rem a foreign bottomry bond given without necessity, following in this matter the English courts, both regarding jurisdiction and substantive law. In *The General Smith*, 4 Wheat. 438, 4 L. Ed. 609, decided in 1819, the court dismissed for want of jurisdiction a libel in rem by a materialman for repairs to a domestic ship. So far as the decision went, it was in accord with the English common law, was opposed to the English admiralty law and to the admiralty law of the continent. It overruled the case of *Stevens v. The Sandwich*, and solved the doubt expressed by Mr. Justice Story in *The Jerusalem*. In a short opinion, however, he asserted two very important principles which have now become established as part of the substantive law of American admiralty. These principles may best be understood by quoting the whole of the opinion:

"No doubt is entertained by this court that the admiralty rightfully possesses a general jurisdiction in cases of materialmen; and, if this had been a suit in personam, there would not have been any hesitation in sustaining the jurisdiction of the district court. Where, however, the proceeding is in rem to enforce a specific lien, it is incumbent upon those who seek the aid of the court to establish the existence of such lien in the particular case. Where repairs have been made or necessaries have been furnished to a foreign ship, or to a ship in a port of the state to which she does not belong, the general maritime law, following the civil law, gives the party a lien on the ship itself for his security; and he may well maintain a suit in rem in the admiralty to enforce his right. But in respect to repairs and necessaries in the port of a state to which the ship belongs the case is governed altogether by the municipal law of that state, and no lien is implied, unless it is recognized by that law. Now, it has been long settled—whether originally upon the soundest principles it is now too late to inquire—that by the common law, which is the law of Maryland, materialmen and mechanics furnishing repairs to a domestic ship have no particular lien upon the ship itself for the recovery of their demands. A shipwright, indeed, who has taken a ship into his own possession to repair it, is not bound to part with the possession until he is paid for the repairs, any more than any other artificer.

But if he has once parted with the possession, or has worked upon it without taking possession, he is not deemed a privileged creditor having any claim upon the ship itself."

The learned judge, speaking for the supreme court, therefore asserted: First. That the court of admiralty possesses a general jurisdiction to enforce contracts for supplies and repairs. In asserting this he was in accord with Judge Winchester and with the theory of the English admiralty courts; but he was opposed to the English courts of common law, and to the Southern admiralty courts, as is shown in the cases above referred to. Second. He asserted that, if the case at bar had been a libel in personam, the court would have had jurisdiction. In this he agreed with the most ancient claim of the English admiralty courts, though they had ceased contending for it long before they were forced to abandon their jurisdiction over libels in rem; and perhaps he agreed with Judge Winchester, though this is doubtful. He was opposed to the courts of common law, to the compromise which the admiralty court made with the common-law courts in 1632, and to the Southern admiralty decisions. Third. That there was no lien for repairs upon a domestic ship. Here he was opposed to the theory of the English admiralty courts, to the continental courts, to Judge Winchester, and, though his conclusion was that of the English courts of common law, yet the conclusion was reached by drawing a distinction diametrically opposed to that which the common-law courts had consented to draw in 1632. Judge Story asserted that a libel in personam could be maintained where a libel in rem could not be. Except from his own intimation in *The Jerusalem*, above referred to, no court or judge, so far as is known, had ever suggested this distinction, while not a few courts had suggested that precisely the opposite distinction was maintainable. Fourth. Judge Story asserted that the general maritime law, following the civil law, gave to the materialman a lien for necessities furnished in a foreign port. The general maritime law, as has been shown, gave a lien or privilege whether the supplies were furnished in a foreign or in a domestic port, though the results of the lien were somewhat different in the two cases. In respect of domestic repairs, he asserted that the case was governed by the municipal law. It is hard to say how far this corresponds to the continental view of the subject, for on the continent there was little distinction between municipal and maritime law. His statement regarding the lien on a domestic vessel did represent the law in England to some extent, but with the important qualification that, if the municipal law there gave a lien,—and it did give one to a materialman retaining possession of the vessel,—then that lien was enforceable only in common-law courts, and not in the admiralty. Here again the learned judge seems not to have perceived clearly the difference between jurisdiction and substantive law. The decision in *The General Smith* has not been overruled, notwithstanding its partial opposition to the general system of maritime law, but some of the principles stated in the opinion of the learned judge were not established for a long time. See the criticism of Mr. Justice Story's opinion in the dissenting opinion of Mr. Justice Clifford in *The Lot-tawanna*, 21 Wall. 558, 593, 22 L. Ed. 654.

In *The St. Jago de Cuba*, 9 Wheat. 409, 6 L. Ed. 122, the claims of the materialmen for supplies, unsupported by bottomry or other hypothecation, were enforced against the proceeds of a vessel condemned for violation of law, in preference to the claim of the government; and Mr. Justice Johnson, who, it will be observed, maintained both before and afterwards that the English admiralty limitations prevailed in this country, stated, in delivering the opinion of the court, at page 416, 9 Wheat., and page 122, 6 L. Ed.:

"For these purposes the law maritime attaches the power of pledging or subjecting the vessel to materialmen to the office of shipmaster, and considers the owner as vesting him with those powers by the mere act of constituting him shipmaster. The necessities of commerce require that when remote from his owner he should be able to subject his owner's property to that liability without which it is reasonable to suppose he will not be able to pursue his owner's interests. But when the owner is present the reason ceases, and the contract is inferred to be with the owner himself, on his ordinary responsibility, without a view to the vessel as the fund from which compensation is to be derived."

The first two sentences just quoted do undoubtedly express the general maritime law, but the third sentence does not, unless its application is limited to bottomry. As has been shown, there is no doubt that the general admiralty law, both in England and on the continent, recognized and enforced against the ship the lien of a materialman for supplies furnished in a home port. Whatever was his error regarding the general maritime law, it is clear that Mr. Justice Johnson did not suppose that he was departing from English precedent. *De Lovio v. Boit* had then been decided for 10 years, but *The Levi Dearborn* had not been overruled by any actual decision of the supreme court. As has been said, the English common-law courts allowed the court of admiralty jurisdiction over foreign bottomry bonds, and, even in the absence of bottomry, they for some time allowed the admiralty to satisfy the claims of materialmen, where the vessel had been sold for other sufficient reason,—as had happened in *The St. Jago de Cuba*,—and the proceeds were in the admiralty court. In *Ramsay v. Allegre*, 12 Wheat. 611, 6 L. Ed. 746, decided in 1827, the court, speaking by Chief Justice Marshall, in an opinion of half a dozen lines refused to permit a libel in personam for materials furnished in a home port in a case where the libellant had not surrendered a negotiable note given for the debt, "it not being necessary to consider the general question of jurisdiction." See *Andrews v. Wall*, 3 How. 568, 573, 11 L. Ed. 729. Believing that the court was drifting almost imperceptibly from the true principles of maritime law, and feeling the responsibility arising from his silent concurrence in the opinion in *The General Smith* and from his own opinion in *The St. Jago de Cuba*, Mr. Justice Johnson delivered an elaborate concurring opinion, in which he maintained that the limitations of admiralty jurisdiction were the same in America as in England. He vigorously condemned the language of the opinion in *The General Smith*, the decision in *The Sandwich*, and the reasoning of *De Lovio v. Boit*. The opinions of Mr. Justice Story have prevailed all along the line, but there is no doubt that Mr. Justice Johnson clearly established as a matter of history that in permitting a libel in personam

where he denied a libel in rem the former had asserted a doctrine hitherto unknown to any law. The opinion of the chief justice in *Ramsay v. Allegre* reopened the question which might have been supposed to be closed by the opinion of Mr. Justice Story in *The General Smith*. In *Peyroux v. Howard*, 7 Pet. 324, 8 L. Ed. 700, the court sustained a libel in rem for repairs in a case where a lien for them was given by the local law. This decision is, of course, opposed to the rule established in England by the common-law courts, and in effect it went far to give a lien to the domestic materialman, inasmuch as a lien is not uncommonly given him by the local law. Mr. Justice Johnson was then a member of the court, but apparently thought it unnecessary to dissent. It is hard to see how he can have agreed with either the decision or the opinion. In the latter but little attention was paid to the question of jurisdiction, and the dictum in *The General Smith* was followed, the statement there made concerning the difference between foreign and domestic repairs being repeated. The real contest in the case arose from a doubt whether the waters in which the vessel plied, being those of the Mississippi river, were within the admiralty jurisdiction. In *Waring v. Clarke*, 5 How. 441, 12 L. Ed. 226, a libel in rem for a collision which took place above the ebb and flow of the tide and within the body of the county was sustained. The general limits of the English admiralty jurisdiction were for the first time specifically repudiated by the supreme court against the single dissent of Mr. Justice Woodbury. The particular matter involved does not concern us here, but the decision is noteworthy for the fact just stated. In *New Jersey Steam Nav. Co. v. Merchants' Bank of Boston*, 6 How. 344, 12 L. Ed. 465, the jurisdiction of the court of admiralty over maritime contracts in general by libels in personam was sustained after full consideration, thus finally establishing as settled law another of the dicta in *The General Smith*. In *Bogart v. The John Jay*, 17 How. 399, 15 L. Ed. 95, the jurisdiction of the admiralty court to enforce payment of the mortgage of a vessel by its condemnation was denied. Mr. Justice Wayne said that the cause of the denial was not the jealousy of the courts of common law. But his reference to English courts and cases makes it probable that the jurisdiction would have been admitted if the jealousy had not existed in the past.

So imperfectly did the most experienced judges of this country understand the relation of the English courts of common law to those of admiralty that in *Carrington v. Pratt*, 18 How. 63, 69, 15 L. Ed. 267, Mr. Justice Nelson referred to *Stainbank v. Fenning*, 11 C. B. 51, as establishing a precedent of substantive admiralty law that a master can pledge the credit of a ship only by a bottomry bond. The English decision referred to was, as has been shown, simply the result of a curtailment of English admiralty jurisdiction, to which the admiralty courts of the United States were not submitted. In spite of the doubt expressed in *Ramsay v. Allegre*, the proposition stated in *The General Smith*, viz., that repairs made in a foreign port generally give a lien enforceable in a court of admiralty, while repairs made in the home port of the vessel give no such lien, has been fully established in the federal courts. *Peyroux v. Howard*, 7 Pet.

324, 341, 8 L. Ed. 700; *New Jersey Steam Nav. Co. v. Merchants' Bank of Boston*, 6 How. 344, 391, 12 L. Ed. 465; *The St. Lawrence*, 1 Black, 522, 17 Am. Dec. 180; *The Lottawanna*, 21 Wall. 558, 22 L. Ed. 654; *The Edith*, 94 U. S. 518, 24 L. Ed. 167; *The J. E. Rumbell*, 148 U. S. 1, 13 Sup. Ct. 498, 37 L. Ed. 345. Yet into so great confusion had this distinction brought the courts that fifty years after *The General Smith* was decided, in *The Lottawanna*, 20 Wall. 201, 219, 22 L. Ed. 259, Mr. Justice Clifford said:

"The bench and bar have come to doubt whether the decision that a maritime lien does not arise in a contract for repairs and supplies furnished to a domestic ship is correct, as it is clear that the contract is a maritime contract, just as plainly as the contract to furnish such repairs and supplies to a foreign ship or to a domestic ship in the port of a state other than that to which the ship belongs." Page 219, 20 Wall., and page 259, 22 L. Ed.

In a later decision made in the same case—*The Lottawanna*, 21 Wall. 558, 22 L. Ed. 654—the whole subject was reviewed, and the distinction stated in *The General Smith* was sustained against the dissent of Mr. Justice Clifford, who criticised *The General Smith* severely. Since *The Lottawanna* the distinction has often been referred to, and has never again been questioned. The reasoning upon which it has been rested has varied, however, and the variety in the reasoning has not always been recognized.

First. The distinction has been rested upon the theory that the general maritime law gives a lien in one case and denies it in the other. Thus, in *Peyroux v. Howard*, 7 Pet. 324, 341, 8 L. Ed. 700, it was said:

"Where the repairs have been made or necessities furnished to a foreign ship, or to a ship in the ports of a state to which she does not belong, the general maritime law gives a lien on the ship as security, and the party may maintain a suit in the admiralty to enforce his right. But as to repairs or necessities in the port or state to which the ship belongs the case is governed altogether by the local law of the state, and no lien is implied unless it is recognized by that law."

See *New Jersey Steam Nav. Co. v. Merchants' Bank of Boston*, 6 How. 344, 391, 12 L. Ed. 465.

In *Ferry Co. v. Beers*, 20 How. 393, 401, 402, 15 L. Ed. 961, it was said:

"In considering the foregoing description, it must be borne in mind that liens on vessels in commerce and are discouraged; so that, where the owner is present, no lien is acquired by the materialman; nor is any where the vessel is supplied or repaired in the home port."

In *Maguire v. Card*, 21 How. 248, 251, 16 L. Ed. 118, it was said:

"We have at this term amended the twelfth rule of the admiralty so as to take from the district courts the right of proceeding in rem against a domestic vessel for supplies and repairs which had been assumed upon the authority of a lien given by state laws, it being conceded that no such lien existed according to the admiralty law."

And in *The Edith*, 94 U. S. 518, 520, 24 L. Ed. 167:

"The repairs having been made on a domestic vessel in her home port, there was no lien for them by the maritime law."

See, also, *The St. Lawrence*, 1 Black, 522, 529, 531, 17 L. Ed. 180; *The Belfast*, 7 Wall. 624, 643, 19 L. Ed. 266.

Yet other opinions of the supreme court have recognized that the general maritime law gives a lien for repairs alike upon a foreign and a domestic vessel. Thus, in the *Lottawanna*, 21 Wall. 558, 571, 22 L. Ed. 654, it was said by Mr. Justice Bradley, in delivering the opinion of the court:

"By the general maritime law, those who furnish necessary materials, repairs, and supplies to a vessel upon her credit have a lien on such a vessel therefor, as well when furnished in her home port as when furnished in a foreign port."

See, to the same effect, *The Kalorama*, 10 Wall. 204, 212, 19 L. Ed. 941.

The court thus recognized that in denying a lien for domestic repairs the law of the United States differs from the general maritime law. It defended the American practice by saying, "No one doubts that every nation may adopt its own maritime code," and, "according to the maritime law as accepted and received in this country, we feel bound to declare that no such lien exists"; i. e., for domestic repairs. 21 Wall. 572, 578, 22 L. Ed. 654. This is to declare a difference between the maritime law of the United States and that of other countries without giving a reason therefor. It is simply *stare decisis*. Perhaps this was all that Mr. Justice Bradley meant to do. Yet into his reasoning crept this statement:

"The proposition, therefore, that by the general maritime law a lien is given in cases of the kind now under consideration, does not advance the argument a single step, unless it be shown to be in accordance with the maritime law as accepted and received in the United States. It certainly has not been the maritime law of England for more than two centuries past. Whether it is the maritime law of this country depends upon questions which are not answered by simply turning to the ordinary European treaties on maritime law, or the codes or ordinances of any particular country." 21 Wall. 574, 22 L. Ed. 654.

As has been shown, the learned justice here fell into historical error. The admiralty law of England certainly gave a lien or right to proceed against the ship for domestic repairs from the earliest times of which we have record, though that lien, as well as the lien for foreign repairs, was denied enforcement for more than two centuries by the prohibitions of the courts of common law. Thus, in *The Albany*, 4 Dill. 439-441, Fed. Cas. No. 131, Judge Dillon said:

"It is equally well known that this principle [lien for domestic repairs] has not been adopted as the law of England; or, rather, after having obtained in the admiralty courts of that country for some time, it was overturned by the hostility of the common-law courts;" "the principle of the civil law in this respect having been, as above observed, overthrown by the early hostility of the common-law courts to the admiralty jurisdiction."

Had Mr. Justice Bradley, in *The Lottawanna*, undertaken to give a reason for the distinction between the American maritime law on the one hand and that of the world at large, including the admiralty law of England on the other, it is likely that he would have fallen into that confusion between English admiralty jurisdiction and substantive law which has already been pointed out.

Second. A modification of the theory just stated, viz., that the general maritime law gives a lien for foreign, but not for domestic re-

pairs, may perhaps be found in *The General Smith* itself, as explained by Mr. Justice Story's observations in *The Jerusalem*. In the latter case Mr. Justice Story had no doubt that "by the general maritime law every contract of the master for repairs and supplies imports an hypothecation"; but in *The General Smith* he held that the general maritime law did not apply in case of a domestic vessel, although the court of admiralty had jurisdiction of the contract. A lien for domestic repairs could be created only by municipal law. In other words, the general maritime law was supposed to give a lien alike upon foreign and domestic vessels, but did not apply in the case of the latter. To this argument it may be answered that, before the distinction between foreign and domestic repairs was established in the courts of the United States, no courts had ever recognized the distinction, except perhaps those of Scotland; not the continental courts, not the English court of admiralty, all which courts recognized the lien in both cases; not the English court of common law, which denied the lien in both cases, and refused to permit the court of admiralty to enforce it in either case. The theory of Judge Story, not clearly expressed, and perhaps not very clearly thought out, seems to have been this: The general maritime law regulates the contracts of foreign vessels, while those of domestic vessels are regulated by municipal law. Of this theory it may be observed: (a) That it was new. No court had suggested the distinction, and generally the court of a country administers the same law to all suitors, at least as to domestic transactions. (b) The words "foreign" and "domestic" are ambiguous. Judge Story did not hold that in a federal court sitting in Massachusetts the lien given by the general maritime law was excluded in case of Massachusetts vessels or in case of Massachusetts materialmen and admitted in other cases. He enforced the lien against a Massachusetts vessel if the materials were supplied elsewhere, and he enforced it in favor of a Massachusetts materialman if the vessel was foreign to Massachusetts. Whether he would have denied it to a French materialman if the vessel also was French and the supplies were furnished in France, is doubtful. See *The Maud Carter* (D. C.) 29 Fed. 156; *The Brantford City*, Id. 373, 384. The case could hardly arise, except where the vessel had been sold for some other cause, and the proceeds were in court for distribution. A distinction in the applicability of municipal law like that suggested is probably unique. (c) Can it be said that "by the general maritime law every contract of the master for repairs and supplies imports an hypothecation," but that the general maritime law does not apply to repairs on a domestic vessel? Is not this to say either. (1) that the general maritime law gives a lien in one case, and not in the other, or (2) that the general maritime law has no application to domestic repairs,—i. e., that the contract is not maritime, which Judge Story said it was. It seems that there is no middle ground.

Third. An ingenious variation of the theory that the distinction between foreign and domestic repairs was based upon a distinction in the general maritime law is to be found in *The St. Lawrence*, 1 Black, 527, 17 L. Ed. 180. Chief Justice Taney said that the judiciary act of 1789 "left no discretionary power in the admiralty courts or

in the superior court in relation to the modes and forms of proceeding. And it is evident that, if the courts of admiralty in this country used the process in rem, or process by attachment of the property in all cases in which it was authorized in countries governed by civil law, it would unavoidably in some cases come in collision with the common-law courts of the state where the parties resided and where the property was situated, and where other parties besides the owners or builders or equippers of the ship might have an interest in or a claim upon the property, which they had a right to assert in the courts of the state. But this difficulty was soon seen and removed. And by the act of May 8, 1792 (1 Stat. 275), these forms and modes of proceeding are to be according to the principles, rules, and usages which belong to courts of admiralty, as contradistinguished from courts of common law, and these forms and modes of proceedings made subject to such alterations as the respective courts might deem expedient, 'or to such regulations as the supreme court of the United States shall think proper from time to time by rule to prescribe to any circuit or district court concerning the same.'" "It was manifestly proper, and perhaps necessary, that this power should be confined to the (supreme) court; for, it being the province of this court to determine what cases came within the admiralty and maritime jurisdiction of the United States, its process and mode of proceeding in such cases should be so framed as to avoid collision with the state authorities where rights of property were involved, over which the state had a right to legislate without trespassing upon the authority of the general government. The power was, therefore, given to the court, not only to make rules upon this subject, but to make them from time to time, so that, if any new difficulty should arise, it might be promptly obviated, and the modes of proceeding and the process of the admiralty courts so molded as to accomplish that object. The case of *The General Smith*, 4 Wheat. 438, 4 L. Ed. 609, was decided upon these principles, and the right to proceed against the property regarded as a mere question of process, and not of jurisdiction. And the court held that where, upon the principles of the maritime code, the supplies are presumed to be furnished on the credit of the vessel, or where a lien is given by the local law, the party is entitled to proceed in rem in the admiralty court to enforce it; but where the supplies are presumed by the maritime code to be furnished on the personal credit of the owner or master, and the local law gives him no lien, although the contract is maritime, yet he must seek his remedy against the person, and not against the vessel. In either case the contract is equally within the jurisdiction of a court of admiralty. And it is obvious from this decision that the court considered the process in rem or priority given for repairs or supplies to a domestic vessel by the courts of admiralty, in those countries where the principles of the civil law have been adopted, as forming no part of the general maritime code, but as local laws, and therefore furnishing no precedent for similar cases where the local law is otherwise. Consequently they form no part of the admiralty and maritime jurisdiction conferred on the government of the United States." 1 Black, 528, 529, 17 L. Ed. 180. This citation, and the opinion in

The *St. Lawrence*, as a whole, show that the learned chief justice believed that the contract for furnishing supplies, whether in a domestic or in a foreign port, was, in its nature, maritime. He recognized that in continental countries generally there existed "process in rem or priority given for repairs or supplies," both in the case of domestic and foreign vessels; and, further, that even the English courts knew no difference between them. He justified the existence of the American practice of admitting the lien in case of foreign repairs and denying it in case of domestic repairs upon the ground that the lien was matter of remedy, and that to admit it in the case of domestic repairs would introduce a conflict between the laws of the state and of the nation. Moreover, he asserted that this principle was the ratio decidendi of *The General Smith*. Ingenious as was his explanation, yet it was unsound. The "maritime code," which the learned judge evidently supposed was in general acceptance, does not regard whether the supplies are presumed to be furnished on the credit of the vessel or not. It makes no presumptions in any case that supplies are furnished on the personal credit of the owner or master. It admits "process in rem or priority given for repairs or supplies" alike to a domestic and to a foreign vessel for the same reason, and on the same general principles, though the lien for foreign supplies may be preferred to that for domestic. Such is the law of the continent in general. Such was the law of the English court of admiralty. It is at least extremely doubtful if the principles of the civil law, "forming no part of the general maritime code," have much to do with the actual practice of continental countries in dealing with a lien for repairs and supplies. Again, it is entirely clear that *The General Smith* was not in fact decided upon the principles enunciated by Chief Justice Taney. Mr. Justice Story did not rest the distinction between foreign and domestic repairs upon any fear of a conflict between federal and state laws, but upon the broad principles of maritime law recognized generally. His meaning is clear, and it was not that attributed to him by Chief Justice Taney. Judge Story had no notion that the supreme court, of its mere motion, was giving a remedy in rem in case of a foreign vessel, and, of the same mere motion, was denying it in case of a domestic vessel for fear of conflict with the state courts. See the criticism of Chief Justice Taney's explanation by Mr. Justice Clifford in *The Lottawanna*, 21 Wall., at page 593, 22 L. Ed. 654.

Fourth. The distinction between foreign and domestic repairs has been supported upon an analogy supposed to exist between the lien for repairs and that given by the express hypothecation of a bottomry bond. In *The Grapeshot*, 9 Wall. 129, 19 L. Ed. 651, the libel was on a bottomry bond, and the opinion made little distinction between the conditions in which such a bond is binding and those which give rise to the ordinary lien for repairs and supplies. After a discussion of the case of the lien, it was said:

"We have been induced to state this doctrine of implied hypothecation somewhat fully, not only because it seemed desirable to correct a common misunderstanding of these cases, but because of the close analogy in origin, effect, and incidents between implied hypothecation and express hypotheca-

tion by bottomry. It is, indeed, difficult to trace, either in reason or in the authorities, any marked line of discrimination between them."

Finally, the court stated its conclusions in the form of a proposition:

"Liens for repairs and supplies, whether implied or express, can be enforced in admiralty only upon proof made by the creditor that the repairs or supplies were necessary, or believed, upon due inquiry and credible representation, to be necessary."

See *Pratt v. Reed*, 19 How. 359, 361, 15 L. Ed. 660.

Yet the wide difference between a bottomry bond and the ordinary lien for supplies is stated by Mr. Justice Curtis in *The Ann C. Pratt*, 1 Curt. 340, 350, Fed. Cas. No. 409:

"One method of determining whether both the implied lien and the express hypothecation by way of bottomry can be intended to exist together is to consider that the first had for its object to secure the repayment of a loan of money, which is absolutely to be repaid, either upon demand or at a stipulated time, and for which the master may pledge the security of the vessel, the owners, and himself; while a loan on bottomry does not oblige the owner personally, is to be repaid only on condition of surviving the perils, the risk of which the lender assumes, and constitutes, as the writers on maritime law have so emphatically declared, an obligation of a distinct and peculiar kind. It is true that in both cases liens exist; but the one is implied by law, the other is created by the act of the master; the one is security for a debt of the owners and the master, the other is a right to receive a sum of money out of the thing at risk, in case it should survive the perils, the hazard of which is assumed by the lender. The one is merely a collateral security for a simple loan; the other is a transaction standing quite by itself, not capable of being analyzed into a loan and a mortgage to secure it, and a contract of insurance, and another of partnership, *undique collatis membris*, but simply a contract of bottomry, unlike all of them, and resembling nothing, and being consistent with nothing, but itself."

It is impossible to state the wide difference between the two liens more strongly. See, to the same effect, *Carrington v. Pratt*, 18 How. 63, 67, 15 L. Ed. 267.

The confusion between bottomry and the simple lien doubtless owes its origin in considerable measure to that rule of the English common-law courts which made suits on a foreign bottomry bond the only suits for repairs and supplies cognizable in the English admiralty court. The limits of English admiralty jurisdiction were again transmuted into rules of substantive American admiralty law.

It has thus been shown that the federal courts have firmly established that there is a distinction in the matter of lien between repairs furnished in the home port of a vessel and repairs furnished in a port foreign to the vessel,—between what we have styled "domestic" and "foreign" repairs. It has been shown also that the distinction, whatever the reasons actually given for it, has arisen from a confusion between the theory of the maritime law, English and continental, and the limits imposed upon the English court of admiralty by the prohibitions issued by the English courts of common law. But, though the historical basis of the distinction is demonstrably unsound, the distinction has been established by competent authority, and cannot be abolished except by legislation. We have next to consider precisely what the distinction is, and what are the conditions under which an implied lien arises by American admiralty law. For the moment, liens given by local statutes are

passed over. The conditions stated are: (1) The port must be foreign. The *J. E. Rumbell*, 148 U. S. 1, 11, 13 Sup. Ct. 498, 37 L. Ed. 345. (2) The repairs must be necessary. The *J. E. Rumbell*; *The Grapeshot*, 9 Wall. 129, 136, 19 L. Ed. 651. (3) They must be made on the credit of the vessel. *Insurance Co. v. Baring*, 20 Wall. 159, 163, 22 L. Ed. 250; *The Emily B. Souder*, 17 Wall. 666, 670, 21 L. Ed. 683. (4) The supplies could not be otherwise obtained. *The Lulu*, 10 Wall. 192, 19 L. Ed. 906. (5) The owner must be absent. *Ferry Co. v. Beers*, 20 How. 393, 401, 402, 15 L. Ed. 961. But the difficulty of enforcing these restrictions soon appeared.

First. The ports of another state were declared to be foreign ports, so that, as in the case at bar, a foreign port may be in full sight of the owner's office, accessible in 10 minutes by ferry and in a minute by telephone. Thus, repairs executed in New York City on a vessel owned in Buffalo or in Ogdensburg are deemed to be executed on a domestic vessel, while repairs on a vessel owned in Jersey City are deemed to be executed on a foreign vessel. Supplies furnished in Erie to a vessel owned in Philadelphia give no lien, but supplies furnished in Camden give one. See *The General Burnside* (C. C.) 3 Fed. 228. The vessel may have been taken across the river for the express purpose of creating a lien. See *The William Cook* (D. C.) 12 Fed. 919. The supplies may be furnished in sight of the owner as he sits in his office at home, yet the vessel may be in a foreign port. Considering that the lien is enforceable only in the federal courts, the distinction between foreign and domestic ports has become in the highest degree artificial. Again, the attempt to fix the home port of the vessel, as between the port of enrolment, the home of the charterer, the home of the general owner, the home of the majority of the owners, etc., shows the artificiality of the rule. *The Jennie B. Gilkey* (C. C.) 19 Fed. 127. *The Thomas Fletcher* (C. C.) 24 Fed. 375. So, where a vessel really domestic is by misrepresentation made to appear foreign, there is a lien. *McAllister v. The Sam Kirkman*, Fed. Cas. No. 8,658; *The Walkyrien*, 11 Blatchf. 241, Fed. Cas. No. 17,092.

Second. The repairs must be necessary. In *Pratt v. Reed* this condition was stated with great strictness. "It is only under very special circumstances, and in an unforeseen and unexpected emergency, that an implied maritime hypothecation can be created." 19 How. 361, 15 L. Ed. 660. But in *The Grapeshot*, 9 Wall. 129, 137, 19 L. Ed. 651, the expressions used in *Pratt v. Reed* were considerably modified. On page 141, 9 Wall., and page 651, 19 L. Ed., it was said that the repairs must be necessary, or believed to be so on due inquiry and credible representation. Necessity exists, however, if a prudent owner would order the repairs on the credit of the ship; and, if the master orders the supplies on the credit of the ship, necessity is sufficiently proved in favor of a materialman who acts in good faith. This, it is submitted, reduces the requirement of necessity for the repairs to a requirement that, in ordering them, the master is reasonably believed to be acting for the benefit of the vessel, and within the scope of his authority. *The Gustavia*, 1 Blatchf. & H. 189, Fed. Cas. No. 5,876.

Third. That credit must be given to the vessel is asserted. The *Lottawanna*, 20 Wall. 201, 219, 22 L. Ed. 259. But in the *Patapsco*, 13 Wall. 329, 333, 334, 20 L. Ed. 696, it was said:

"It is undisputed that The *Patapsco* was in a foreign port, and that the coal was ordered for her specifically by name, and delivered to the officers in charge of her. It is equally free from dispute that the supply of coal was necessary—indeed, indispensable—to enable her to make her voyage at all. In such a case the inference is that the credit was given to the vessel, unless it can be inferred that the master had funds, or the owners had credit, and that the materialman knew of this, or knew such facts as should have put him on inquiry." "If the credit was to the vessel, there is a lien, and the burden of displacing it is on the claimant. He must show affirmatively that the credit was given to the company to the exclusion of a credit to the vessel."

And in *The Emily B. Souder*, 17 Wall. 667, 670, 671, 21 L. Ed. 683, it was said:

"The presumption of law always is, in the absence of fraud or collusion, that, where advances are made to a captain in a foreign port, upon his request, to pay for necessary repairs or supplies to enable his vessel to prosecute her voyage, or to pay harbor dues, or for pilotage, towage, and like services rendered to the vessel, that they are made upon the credit of the vessel as well as upon that of her owners. It is not necessary to the existence of the hypothecation that there should be in terms any express pledge of the vessel, or any stipulation that the credit shall be given on her account. The presumption arises that such is the fact from the necessities of the vessel, and the position of the parties considered with reference to the motives which generally govern the conduct of individuals. Moneys are not usually loaned to strangers, residents of distant and foreign countries, without security, and it would be a violent presumption to suppose that such course was adopted when ample security in the vessel was lying before the parties."

The necessity arising in Jersey City from the absence of the owner in the "distant and foreign country" of New York is not to be spoken of seriously, yet this is the necessity which is made to create the lien. "The position of the parties considered with reference to the motives which generally govern the conduct of individuals" is the same whether the vessel is at Harlem or Hoboken. In view of the cases cited, it seems that the requirement of credit to the vessel amounts to no more than this: That the materialman must not have waived his ordinary lien. As was said by Mr. Justice Story in *The Nestor*, 1 Sumn. 73, 75, Fed. Cas. No. 10,126:

"It is, in the first place, said that here a personal credit was given to the master, excluding any credit to the owner or to the ship. Now, I agree that, if the libellant has given any exclusive personal credit to the master, he cannot afterwards, upon any change of circumstances or opinion, resort to the ship, or shift the responsibility over upon the owner. But prima facie the supplies of materialmen to a foreign ship—that is, to a ship belonging, or represented to belong, to owners resident in another state or country—are to be deemed to be furnished on the credit of the ship and the owners, until the contrary is proved."

So in *Carrington v. Pratt*, 18 How. 63, 68, 15 L. Ed. 267, it was said:

"Now, it is well settled that the lien implied by the general admiralty law may be waived by the express contract of the parties or by necessary implication, and the implication arises in all cases where the express contract is inconsistent with an intention to rely upon the lien."

Here the failure to look to the vessel is treated as a positive waiver of the lien, rather than a positive looking to the vessel as a prerequisite of the lien. In *The George T. Kemp*, 2 Low. 477, 481, Fed. Cas. No. 5,341, Judge Lowell said:

"I have never known a ship-chandler that did not prefer two securities to one; and it has been the usage of the trade to make their charges to the ship and owners, hoping and intending to have the security of both."

See *Peyroux v. Howard*, 7 Pet. 324, 344, 345, 8 L. Ed. 700; *The Sidney L. Wright*, 5 Hughes, 474, Fed. Cas. No. 6,082a; *The H. B. Foster*, 3 Ware, 165, Fed. Cas. No. 6,291; *Jones v. The Ratler*, Taney, 456, Fed. Cas. No. 7,490; *The Prospect*, 3 Blatchf. 526, Fed. Cas. No. 11,443; *The Washington Irving*, Fed. Cas. No. 17,244.

Inasmuch as the affirmative giving of credit to the vessel is not required by the maritime law in general, and is generally presumed in the United States, where the other necessary conditions exist, it seems that the requirement comes to no more than this: That the lien may be waived by the express or implied giving of credit exclusively to the owner or master. Where the supplies are ordered, not by the master, but by the owner, it is said that there must be some affirmative evidence that the credit of the vessel was pledged. *The George Farwell*, 43 C. C. A. 373, 103 Fed. 882; *The Roanoke*, 46 C. C. A. 618, 107 Fed. 743. But there need be no express statement. *The Newport* (D. C.) 107 Fed. 744; *The Ella* (D. C.) 84 Fed. 471, 477; *The Stroma*, 3 C. C. A. 530, 53 Fed. 281, 283, 284; *The Havana*, 35 C. C. A. 148, 92 Fed. 1007.

Fourth. It has been said that a necessity for pledging the credit of the vessel must exist to create the lien, but in *The Lulu*, 10 Wall. 192, 197, 19 L. Ed. 906, it was said:

"Where it appears that the repairs and supplies were necessary to enable the vessel to proceed on her voyage, and that they were made and furnished in good faith, the presumption is that the vessel, as well as the master and owners, is responsible to those who made the repairs and furnished the supplies, unless it appears that the master had funds on hand or at his command which he ought to have applied to the accomplishment of those objects, and that they knew such was the fact, or that such facts and circumstances were known to them as were sufficient to put them upon inquiry, and to show that, if they had used due diligence in that behalf, they might have ascertained that the master, under the rules of the maritime law, had no authority to contract for the repairs and supplies on the credit of the vessel." And again: "Where proof is made of necessity for the repairs and supplies, or for funds raised by the master to pay for the same, and of credit given to the ship, a presumption will arise," said the chief justice, "in the absence of evidence to the contrary, of necessity for credit. Remarks are made in two cases decided by this court quite at variance with that rule, but it is unnecessary to comment upon those cases, or to enter into any explanation of those remarks, as it is clear that, if they assert any different rule of decision, they are in that respect directly overruled." 10 Wall. 203, 19 L. Ed. 906.

See *The Grapeshot*, 9 Wall. 129, 138, 19 L. Ed. 651.

And in *The Bertha M. Miller*, 24 C. C. A. 641, 79 Fed. 365, 366, it was said by the circuit court of appeals for this circuit:

"The necessity of the supplies is presumed from their nature, and from the fact that the master orders them; and, in the absence of other facts, the necessity for binding the vessel may also be presumed. But if the material-

man knows that the captain has funds or means of his owners or of his own, credit to the vessel is not authorized, and no lien is created."

It has been suggested (see *Cuddy v. Clement*, 51 C. C. A. 288, 113 Fed. 454, 462) that necessity for pledging the credit of the vessel is presumed when supplies are ordered by the master, but that it must be shown when they are ordered by the owner. But is there not more than a mere presumption of necessity in the case first put? Let us suppose a vessel coaling in Jersey City under the eyes of her wealthy owner, whose ownership and wealth are known to the materialman and whose office is in a high building on the west side of New York City. In the absence of some agreement to the contrary, would not a lien arise if the coal was needed for the voyage and was furnished on the order of the master? I think so, and yet, if this be true, it is idle to talk of necessity for pledging the vessel as a condition of the existence of the lien. If no lien arises in the case put, what degree of distance and what restriction of assets is needed to create the lien? Does it exist as against a vessel of the Cunard Company in a port where the company is unrepresented? The necessity is precisely the same whether the coal is ordered by the owner or the master. In *Cuddy v. Clement* the court found that the contract for coal was made in fact on the credit of the owner; that is to say, that any lien on the vessel was waived. Upon the whole it seems that the fourth requirement amounts but to this: That there is no lien where the materialman knows, or ought to know, that the master has funds which he may properly apply to payment for the supplies. The requirement is one of reasonable good faith. If any more is required by *Thomas v. Osborn*, 19 How. 22, 31, 15 L. Ed. 534, the expressions in that case must be deemed modified by those in *The Lulu*. See *Berwind v. Schultz* (D. C.) 25 Fed. 912, a libel in personam.

Fifth. The requirement of the absence of the owner is the most difficult and important. It has been put upon two grounds entirely unconnected:

(a) In *Ferry Co. v. Beers*, 20 How. 393, 401, 15 L. Ed. 961, it was said:

"It must be borne in mind that liens on vessels incumber commerce, and are discouraged; so that, where the owner is present, no lien is acquired by the materialman; nor is any where the vessel is supplied or repaired in the home port. The lien attaches to foreign ships and vessels only in favor of the carpenter who repairs in a case of necessity and in the absence of the owner."

And in *Pratt v. Reed*, 19 How. 359, 361, 15 L. Ed. 660, it was said:

"These maritime liens in the coasting business and in the business upon the lakes and rivers are greatly increasing; and, as they are tacit and secret, are not to be encouraged, but should be strictly limited to the necessities of commerce which created them. Any relaxation of the law in this respect will tend to perplex and embarrass business, rather than furnish facilities to carry it forward."

This is to say that a secret lien is so undesirable that it can be allowed only in case of a necessity which is evidenced, in part at least, by the absence of the owner. In *Pratt v. Reed* the master was owner, and this fact, though not conclusive, was deemed to make

against the existence of the lien. The limitation is thus imposed, in part at least, for the benefit of third persons having claims on the vessel,—the mortgagee, the vendee, prior or subsequent, and the general creditor. See *The Lottawanna*, 21 Wall. 558, 571, 22 L. Ed. 654. For a favorable criticism of secret liens, see *The Eliza Jane*, 1 Spr. 152, Fed. Cas. No. 4,363.

(b) On the other hand, in *The Valencia*, 165 U. S. 264, 271, 17 Sup. Ct. 323, 325, 41 L. Ed. 710, it was said that:

“In the absence of an agreement, express or implied, for a lien, a contract for supplies made directly with the owner in person is to be taken as made ‘on his ordinary responsibility, without a view to the vessel as the fund from which compensation is to be derived.’”

And in *The Kalorama*, 10 Wall. 204, 213, 214, 19 L. Ed. 941, it was said:

“It is no objection to his [the master’s] authority that he acted on the occasion under the express instructions of the owner, nor will the lien of those who made the repairs and furnished the supplies be defeated by the fact that his authority emanated from the owner, instead of being implied by law.” “When the owner is present, the implied authority of the master for that purpose ceases; but, if the owner gives directions to that effect, the master may still order necessary repairs and supplies, and, if the ship is at the time in a foreign port, or in the port of a state other than that of the state to which she belongs, those who make the advances will have a maritime lien, if they were made on the credit of the vessel.” “Implied liens, it is said, can be created only by the master, but if it is meant by that proposition that the owner, or owners, if more than one, cannot order repairs and supplies on the credit of the vessel, the court cannot assent to the proposition, as the practice is constantly otherwise. Undoubtedly, the presence of the owner defeats the implied authority of the master, but the presence of the owner would not destroy such credit as is necessary to furnish food to the mariners, and save the vessel and cargo from the perils of the sea.”

And the extended discussion in *The Kate*, 164 U. S. 458, 465–470, 17 Sup. Ct. 135, 41 L. Ed. 512, treats the lien as created by authority confided in the master by the owner. This is to say that the nonexistence of the lien in the presence of the owner arises from a want of authority in the master to bind the vessel when the owner himself is present. This appears to be the theory stated in *The Lulu*, 10 Wall. 192, 200, 19 L. Ed. 906, and in *Insurance Co. v. Baring*, 20 Wall. 163, 164, 22 L. Ed. 250, where want of authority is treated as the only limitation on the master’s authority. See *The Eclipse*, 3 Biss. 99, Fed. Cas. No. 4,268; *The Ludgate Hill* (D. C.) 21 Fed. 431; *The Isaac May*, Id. 687; *The Ella* (D. C.) 84 Fed. 471; *The Marion S. Harris*, 29 C. C. A. 428, 85 Fed. 798; *The North Pacific*, 40 C. C. A. 510, 100 Fed. 490. It is this theory, and not (a), which seems now to be accepted by the federal courts. Even in *The Mary Morgan* (D. C.) 28 Fed. 196, where the absence of the owner as a condition of the lien was most strongly insisted on, it was admitted that the owner might create a lien by parol. See *The Havana* (D. C.) 54 Fed. 201. The confusion into which a conflict between the two theories brought the courts is illustrated by *Thomas v. Osborn* and other cases, where the master was owner in whole or in part. If the first theory be sound, there is no lien; if the second, the lien has a double authority. Upon theory (b), the

condition of the owner's absence is imposed wholly for his benefit, and may, therefore, be waived by him either expressly or by implication. His mortgagee or other creditor may be prejudiced by a secret lien, provided the creation of the lien was authorized by him. To this effect agrees the reasoning in cases like *The Walkyrien*, Fed. Cas. No. 17,092, which hold that there is a lien even in a domestic port, provided the materialman is reasonably deceived into believing the vessel to be foreign. If the requirement that the port be foreign is imposed for the benefit of any person other than the owner, it is hard to see why such person should be prejudiced by the misrepresentation of the owner and his agents. For the continental rule, see Valr. I, p. 120. Again, if the condition of the owner's absence exists only for the owner's benefit, and may be waived by him, then the other conditions mentioned above, or most of them, have the same object. Thus it would seem that necessity for credit need not be shown if the owner assents to the creation of the lien when the repairs are made. That the supplies were necessary to the vessel need not be shown, it seems, though doubtless they must be appropriate. It has not been established that the assent of the owner will, in the absence of statute, give a lien for domestic repairs. On the theory just stated, the owner's assent should be sufficient. If the presence of the owner in a foreign port ordinarily defeats the lien, but his assent to the creation of the lien while present and having means will create the lien there, then his assent, sufficiently proved, should create the lien even in the home port. *The George Farwell*, 43 C. C. A. 373, 103 Fed. 882, appears to be in point, though it must be admitted that the grounds of the decision are not perfectly clear. The charterer had its place of business in New York. By the charter it was bound to pay for repairs and keep the vessel clear of liens. The owner was of Ohio. The repairs were done in New York on the order of the charterer. The charterer agreed with the materialman orally for a lien, representing that it owned the vessel. The court sustained the lien on the ground that the materialman was justified in relying on the charterer's statement, which amounted to this: That the repairs were made on the order of the owner in the home port. The court can hardly have intended to allow the materialman to take the charterer's statement of the ownership, and at the same time to set up that the vessel belonged in Ohio, and so was repaired in a foreign port. It must, therefore, have meant to decide that an owner may give a lien for domestic repairs. It is true that the charterer was incorporated in New Jersey, but this seems to have been deemed immaterial, and it was neither urged nor suggested that the vessel belonged in New Jersey. See *The Roanoke* (D. C.) 101 Fed. 298; *Id.*, 46 C. C. A. 618, 107 Fed. 743,—a case which arose out of similar facts. There the libellant supposed the charterer was a New York corporation, and yet both the district court and the court of appeals conceded that, if it had expressly agreed with the libellant for a lien, the lien would have bound the vessel. See, also, *The Allianca* (D. C.) 63 Fed. 726, 732; *Taylor v. Com.*, Fed. Cas. No. 13,788; *The Union Express*, Fed. Cas. No. 14,363. The ordinary absence of a lien in the home port and its absence in a for-

eign port when the owner is present apparently have the same cause, to wit, a want of authority given by the owner to the master sufficient for the creation of the lien. *The Union Express*, 1 Brown, Adm. 537, Fed. Cas. No. 14,364. According to many cases, the personal order of the owner gives rise to a presumption that the supplies ordered are furnished on his personal credit; but this presumption, which probably arose from a confusion with the more reasonable presumption that the master could not bind the vessel in the owner's presence, would soon disappear if owners generally assented to a lien upon their vessels for supplies and repairs ordered by themselves. The supposed analogy between the lien and a bottomry bond leads to the same conclusion. Though the analogy be misleading, yet the reference to it by the courts may show the line of their reasoning. Now, the master cannot give a bottomry bond in the home port, but the owner can do so. *The Charles Carter*, 4 Cranch, 328, 2 L. Ed. 636; *The Draco*, 2 Sumn. 157, Fed. Cas. No. 4,057. And see Ames cases on admiralty 230, note. Necessity to borrow need not be shown. Apparently the English court of admiralty requires proof of emergency in case of bottomry by owner. *The Dunvegan Castle*, 3 Hagg. Adm. 331; *The Hersey*, Id. 404. It is true that the tendency upon the continent of Europe is greatly to limit bottomry, if not to do away with it altogether, but no tendency is shown to narrow the scope of maritime liens. On the whole, the theory gains strength and is prevailing that the limitations upon the lien exist for the sole benefit of the owner, and may be waived by him either expressly or by implication. This theory is supported by those cases in which a lien has been declared, though the supplies were ordered by the owner himself in the home port of the vessel, provided they were put on board in a foreign port. *The Agnes Barton*, 26 Fed. 542. The lien exists even if the vessel was in the home port at the time the supplies were ordered; *The Hiram R. Dixon* (D. C.) 33 Fed. 297. To give a lien for supplies ordered by the owner in New York, the place of his residence, where the vessel is then lying, because these supplies are, for the sake of convenience, forwarded to Jersey City, and there taken on board by the vessel, is to make the rights of the materialman depend upon a distinction without substantial difference. To say that the lien arises in such case because the supplies are furnished "in a case of necessity and in the absence of the owner," "in an unforeseen and unexpected emergency," because "moneys are not usually loaned to strangers, residents of distant and foreign countries," or because "of a reasonable impracticability of obtaining (the supplies) on the credit of the owner," is not to reason conclusively. This conclusion is strengthened by the analogy of statutory liens, the history of which is stated in *The Glide*, 167 U. S. 606, 17 Sup. Ct. 930, 42 L. Ed. 296. In their case: (1) The port not only may be, but is ordinarily, domestic. (2) The repairs and supplies are those covered by the statute, and need not be necessary, though probably they must be appropriate. (3) No credit need be given to the vessel, though doubtless the lien may be waived, either expressly or by implication. *The Iris*, 40 C. C. A. 301, 100 Fed. 104. (4) No necessity for pledging the credit of the vessel need

be shown. (5) The owner need not be absent. He may order the repairs himself.

The history of maritime liens for supplies and repairs has thus been traced. Their origin is ancient, and not precisely ascertained. Whatever was their connection with bottomry, they were early limited by different conditions, and they produced different results. They were recognized, both in England and on the continent, to bind both domestic and foreign vessels, and have generally bound both upon the continent. Until confusion between jurisdiction and substantive law had bred ignorance of the latter, no one disputed that both were bound by the admiralty law of England, but that law was denied enforcement by the English courts of common law in the case of both foreign and domestic repairs (saving only cases of foreign bottomry and of a sale of the vessel for other sufficient reasons). In this country the colonial courts of admiralty, though theoretically bound by the English limitations, may yet have been less hampered in practice by prohibitions. When, after the adoption of the federal constitution, the federal courts, with much difference of opinion, came to disregard the limits of English admiralty jurisdiction, they yet did not free themselves altogether from the habits of thought which these limits had imposed. Questions of jurisdiction and of substantive law were thus confused here as well as in England, and that which the courts of admiralty had been forbidden to do by prohibition was believed to have been left undone voluntarily. Thus a distinction was established between foreign and domestic repairs, elsewhere unknown (except perhaps in Scotland), and this distinction was further confused by a distinction between *libels in rem* and *in personam*. From this confusion has emerged in the United States a theory, not consistently developed as yet, that, subject to not a few presumptions and counter presumptions, exceptions and subexceptions, a vessel is ordinarily liable for her repairs and supplies. Here the personification of the vessel has been more fully developed than in England, and it has been made the foundation of our admiralty law. (This personification, so far as it existed in England, has recently been denied effect in *The Gemma* (1899) P. D. 285, with what results to the English admiralty law it remains to discover.) The exceptions to this general rule of the vessel's liability for repairs and supplies exist for the protection of the owner of the vessel, and for his protection only, although, if the exception is established, the materialman is deemed to have waived his lien, and this waiver may be availed of by other creditors of the owner. If the owner refuses to permit the creation of the lien or right to proceed against the vessel, and this refusal is or ought to be known to the materialman, no lien arises, or else it is deemed to be waived. From the existence of certain circumstances this refusal of the owner and the consequent nonexistence or waiver of the lien are presumed, but the effect to be given these circumstances may vary with local customs. In any event, the assent of the owner to the existence of the lien, actual or reasonably implied, suffices for its creation.

It cannot be pretended, of course, that this review and discussion of the history and law of maritime liens for repairs and supplies is

complete. It is hoped that what has been said has cleared up some misconceptions, and will help both to a better understanding of the subject and to its further study.

It remains to consider the case at bar in the light of the results already reached. Did this owner assent to the lien in this case? Did he lead the materialman to believe in his assent? Ought the materialman to have known that the owner dissented? All the circumstances by which the lien is ordinarily created or from which it is ordinarily presumed are here present,—the foreign port, the order of the master, the absence of the owner, the need of supplies if the vessel is to navigate, the necessity of pledging the credit of the vessel if the supplies are to be procured. To this the defense is: Want of authority in the master, known to the materialman, to create the lien upon the vessel. What is meant by the master's want of authority in a matter like this? No law ever provided baldly that the repairer of a vessel should always have a lien. My vessel lies at a wharf out of repair, and she is repaired by a mere trespasser. In general he has no lien under any system of law. The repairs must be ordered or authorized by some one in authority, and the master is ordinarily such a person either at home or abroad; that is to say, the master ordinarily has authority to license the act of repairing. If authorized by him, it is no longer a trespass. If the owner has given the master express authority to contract for repairs or supplies, the owner is bound personally. If the repairs are within the scope of the authority which the maritime law attributes to the master, and that authority has not been specially limited, the owner or the charterer, that person of whom the master is agent, is personally bound to pay for the repairs. All this is a development of the ordinary law of agency. By English law it seems that the owner is bound, even if the advances for repairs, etc., are made in a domestic port. *Abb. Shipp.* (7th Am. Ed.) 186; *Arthur v. Barton*, 5 Mees. & W. 138; *Johns v. Simons*, 2 Q. B. 425; *The Lochiel*, 2 W. Rob. Adm. 45. See *Speerman v. Degrave*, 2 Vern. 643. The owner is bound by the act of his authorized agent, as if he had ordered the repairs himself. If the owner is actually present in the port, something more than the ordinary implied authority of the master may be necessary to bind the owner for repairs, even if not for supplies. By a peculiarity of the maritime law the master also is bound individually, but this peculiarity need not concern us here. Whatever be the authority ordinarily given to a master, if in the particular case he has no authority to bind his principal, and if the material man knows this want of authority, the owner or principal cannot be held. This also is the familiar law of agency. So, if the master has no authority to permit the materialman to make the repairs, and the materialman, who makes them on the master's order, knows this want of authority, it is hard to see how he can justify his trespass. If he knows that the master is forbidden to create a debt binding upon the owner, he cannot hold the owner. If he knows that the master is forbidden to permit the creation of a lien on the ship, he cannot claim a lien. Put the case in another way: If the materialman knows that the master is forbidden to repair, even in a foreign port, it would seem

that he cannot proceed against either owner or vessel. If he knows that the master is permitted to repair, but only upon the condition that the repairs are chargeable neither to the owner nor to the vessel, then, if he makes the repairs on the order of the master, and without objection, it would seem that he impliedly waives his lien upon the vessel. See *Emerigon*, in *Hall's Maritime Loans*, 89, 90. It is true that the maritime law and its codes give great power to the master. But these powers must be subject to enlargement and diminution by agreement between owner and master. In general, the latter cannot hold the former by the general rules of maritime law against an express agreement duly entered into between them, and it is hard to see how he can bind him in contravention of the agreement to a third person who has knowledge of its terms. We need not here discuss the statutory lien. The terms of the statute may expressly give to the master authority to create a lien, whether the owner authorizes it or not. See *The Kate*, 164 U. S. 458, 470, 17 Sup. Ct. 135, 41 L. Ed. 512; *The S. M. Whipple* (D. C.) 14 Fed. 354.

The mere fact that a vessel is known to be under charter does not deprive of his lien one who, in a foreign port, furnishes it with supplies on the order of the master. *The George Dumois*, 15 C. C. A. 675, 68 Fed. 926; *The Philadelphia*, 21 C. C. A. 501, 75 Fed. 684. But if a charter or other contract limits the authority of the master in the matter of buying coal, and forbids him to buy it except upon the personal credit of the charterers only (and perhaps on his own personal credit), and if the libellant has notice of this limitation, it would seem that the lien either does not arise or is impliedly waived. In *The Kate*, 164 U. S. 458, 17 Sup. Ct. 135, 41 L. Ed. 512, Mr. Justice Harlan said:

"Courts of admiralty will not recognize and enforce a lien upon a vessel when the transaction upon which the claim rests originated in the fraud of the master upon the owner, or in some breach of the master's duty to the owner, of which the libellant had knowledge, or in respect of which he closed his eyes without inquiry as to the facts. If no lien exists under the maritime law, when supplies are furnished to a vessel upon the order of the master under circumstances charging the party furnishing them with knowledge that the master cannot rightfully, as against the owner, pledge the credit of the vessel for such supplies, much less is one recognized under that law where the supplies are furnished, not upon the order of the master, but upon that of the charterer, who did not represent the owner in the business of the vessel, but who, as the claimant knew, or by reasonable diligence could have ascertained, had agreed himself to provide and pay for such supplies, and could not, therefore, rightfully pledge the credit of the vessel for them."

The learned justice also quoted from an opinion rendered by Judge Sprague in this court in *The Sarah Starr*, 1 Spr. 453, 455, Fed. Cas. No. 12,354, where it was said:

"In giving credit to the vessel and owners, the materialman should act in good faith, and he would not be deemed to act in good faith if he knew that the master had funds wherewith to pay for the supplies, or if facts were known to him which should create suspicion, and put him upon inquiry, when such inquiry would have led to the knowledge that the master had funds, and has no right, therefore, to obtain supplies on credit. That is, if the materialman had had knowledge that the master was acting in bad faith towards his employers, or knew of circumstances which ought to admonish him to make inquiry that would have led to such knowledge, then he would be af-

fectured with bad faith, as colluding with the master, and aiding him in violating his duty to his owner. But if the materialman had no reason to suppose that the master was violating his duty in obtaining a credit, he might, upon request of the master, trust to the vessel and owners, and a lien would thereby be created." 164 U. S. 469, 17 Sup. Ct. 139, 41 L. Ed. 512.

See *The Columbus*, 5 Sawy. 487, Fed. Cas. No. 3,044; *Swift v. The Albus*, Fed. Cas. No. 13,694; *The S. M. Whipple* (D. C.) 14 Fed. 354; *The Alvira* (D. C.) 63 Fed. 144.

In *the Bombay* (C. C.) 38 Fed. 863; *Id.* (D. C.) 38 Fed. 512, it is not stated if the libelants knew that the vessel was under charter, and it is said expressly that they had no notice of its provisions. By the French law it seems that the vessel is not bound for supplies ordered by the charterer unless the supplies are needed for the ship, apart from the special needs of the charterer, and unless the owner, if present, would have ordered them. Desj. I, 256.

One argument in support of the master's authority to bind the vessel, even when expressly forbidden to do so, should not be overlooked. Suppose the charter provides that the owner shall pay the wages of the crew. To put this charge upon the charterer is not uncommon. Suppose the crew to have knowledge that the charter forbids the charterer to create a lien for wages, it may be asked if the crew would lose their lien. In the case put they would have that knowledge of the master's limitation of authority which the materialmen are held to have had in the case at bar. Why should they fare any better? It is probable that the seamen's lien on the vessel would exist even in the case put,—that is to say, even though they knew that the master, in permitting it to arise, was guilty of bad faith. The seamen would be protected, however, not by the logical result of admitted principles of general law, but by reason of the favor shown to them in a court of admiralty. The wages of seamen are secured upon the vessel in many jurisdictions by a statute which admits of no exception. Taking it as established, then, that the vessel is not bound even for necessary supplies furnished in a foreign port on the master's order, provided the materialman knows that the master is forbidden to create a lien for the purpose, we next consider if the master's authority was so limited in this case. The limitation here contended for by the claimant is found in the charter party, whose material parts are as follows:

"(2) The owner shall provide and pay for all the provisions, water, wages, and consular shipping and discharging fees of the captains, officers, engineers, firemen, and crew of said tug; shall pay for the insurance of the same; also for all ship, cabin, engine-room, and deck stores; and maintain said tugs in a thoroughly efficient state in hull and machinery for and during the service, and including the necessary hawsers and lines for mooring and towing.

"(3) The charterer shall provide and pay for all the coals, port charges, pilotages, agencies, and commissions, and all other charges whatsoever, except those before stated, and shall likewise, in case the owner deems it necessary to insure said tugs, or any of them, against war risks, pay the additional cost of the premium for such insurance."

"The charterer shall accept and pay for all coals in the tugs' bunkers on delivery, and the owner shall, on the expiration of this charter party, pay for all coal left in the bunkers, each at the current market prices at the port of Boston when said tugs are delivered to them."

"(6) The captains of said tugs, although appointed by the owner, shall be

under the orders and direction of the charterer as regards employment, agency, or other arrangements, and the charterer hereby agrees to indemnify the owner from all consequences or liabilities that may arise from any irregularities in ship's papers, or from the captains signing bills of lading, or otherwise complying with the charterer's directions."

The court has to consider if this language is (1) a limitation on the authority of the captain, or (2) merely a contract made by the charterer with the owner that the former will pay for supplies in the first instance, and, in case this is not done for any reason, will reimburse the owner for supplies paid for by the latter. The language of the clauses might not unreasonably bear either construction. On general principles there is much to be said in support of the contention that a clause in a charter like that above quoted, providing that the charterer shall supply the vessel with coal, is intended merely as a contract between charterer and owner, and does not limit the general authority of the master to order coal for the vessel upon the vessel's credit in a foreign port. In *The Kate*, above cited, the provisions of the charter were much like those in this case, and the supreme court said at page 465, 164 U. S., page 138, 17 Sup. Ct., and page 512, 41 L. Ed.:

"We are of opinion that, as the libelant knew, or, under the circumstances, is to be charged with knowledge, that the charter party under which the *Kate* was operated obliged the charterer to provide and pay for all the coal needed by that vessel, no lien can be asserted under the maritime law for the value of coal supplied under the order of the charterer, even if it be assumed that the libelant in fact furnished the coal upon the credit both of the charterer and of the vessel. As the charterer had agreed to provide and pay for all coal used by the vessel, he had no authority to bind the vessel for supplies furnished to it. His want of authority to charge the vessel for such an expense was known or could have been known to the libelant by the exercise of due diligence on its part. Under the circumstances, the libelant was not entitled to deliver the coal on the credit of the vessel, and its attempt to hold the vessel liable is in bad faith to the owner. The law cannot approve or encourage such an attempt to wrong the owners of the vessel. Neither reason nor public policy forbade the owner and the charterer from making the arrangement evidenced by the charter party of December 15, 1892. The master of a ship is regarded as 'the confidential servant or agent of the owners, and they are bound to the performance of all lawful contracts made by him relative to the usual employment of the ship, and the repairs and other necessities furnished for her use. This rule is established as well upon the implied assent of the owners as with a view to the convenience of the commercial world.' *The Aurora*, 1 Wheat. 95, 101, 4 L. Ed. 45. 'The vessel must get on,' and 'the necessities of commerce require that, when remote from the owner, he [the master] should be able to subject his owner's property to that liability, without which, it is reasonable to suppose, he will not be able to pursue his owner's interests.' *The St. Jago de Cuba*, 9 Wheat. 409, 416, 6 L. Ed. 122; *The J. E. Rumbell*, 148 U. S. 1, 13 Sup. Ct. 498, 37 L. Ed. 345. When, therefore, supplies are furnished to a vessel in a foreign port upon the order of the master, nothing else appearing, the presumption is that they were furnished on the credit of the vessel and of the owners, and an implied lien is given. But no such necessity can be suggested, and no such reasons urged, in support of an implied lien for supplies furnished to a charterer, when the libelant at the time knew, or by such diligence as good faith required could have ascertained, that the party upon whose order they were furnished was without authority from the owner to obtain supplies on the credit of the vessel, but had undertaken, as between itself and the owner, to provide and pay for all supplies required by the vessel."

There was a like charter in *The Valencia*, 165 U. S. 264, 17 Sup. Ct. 323, 41 L. Ed. 710, and the court said at page 270, 165 U. S., page 325, 17 Sup. Ct., and page 710, 41 L. Ed.:

"Although the libelants were not aware of the existence of the charter party under which the *Valencia* was employed, it must be assumed, upon the facts certified, that by reasonable diligence they could have ascertained that the New York Steamship Company did not own the vessel, but used it under a charter party providing that the charterer should pay for all needed coal. The libelants knew that the steamship company had an office in the city of New York. They did business with them at that office, and could easily have ascertained the ownership of the vessel and the relation of the steamship company to the owners. They were put upon inquiry, but they chose to shut their eyes and make no inquiry touching these matters, or in reference to the solvency or credit of that company."

See *Beinecke v. The Secret* (D. C.) 3 Fed. 665, quoted with approval by the supreme court in the last-named case; *The Cumberland* (D. C.) 30 Fed. 449, 455; *The William Cook* (D. C.) 12 Fed. 919; *Neill v. The Francis* (D. C.) 21 Fed. 921; *The Solveig*, 43 C. C. A. 250, 103 Fed. 322; *The Stroma* (D. C.) 41 Fed. 599; *The Pirate* (D. C.) 32 Fed. 486.

In other cases it was assumed that, if the materialmen had had knowledge of the existence of a charter like that in this case, he would have had no lien, although, as no knowledge on his part was established, the lien was allowed. *The North Pacific*, 40 C. C. A. 510, 100 Fed. 490; *Norwegian S. S. Co. v. Washington*, 6 C. C. A. 313, 57 Fed. 224; *The Ellen Holgate* (D. C.) 30 Fed. 125. These cases construe the language used in this charter to forbid the master to pledge the credit of the vessel for the supplies he orders. Many of these cases, and others heretofore cited, also hold that the materialman is affected by the limitations of the charter if he has notice of them. There is much authority for the proposition that this charter, if brought to the notice of the materialman, will prevent him from getting a lien. It is true that there is authority upon the other side, and that the opinions of the supreme court just cited are not quite explicit. In *The City of New York*, Fed. Cas. No. 2,758, the lien was upheld in the case of a charter like this. The vessel was in a really distant port, however, and was in such peril that the limitation imposed on the master's authority by the charter may have been treated as inapplicable within the intent of the parties. The opinion is short. See *The Wm. Cook* (D. C.) 12 Fed. 919, 920. In *The Lucia B. Ives*, Fed. Cas. No. 8,590, the lien was upheld, but whether in reliance on the express terms of the statute or upon a doubt as to the meaning of the charter is not clear. In *The Monsoon*, Fed. Cas. No. 9,716, decided by Judge Sprague, in which that distinguished judge upheld a lien upon a chartered vessel, it is doubtful if the decision was rested upon a supposed inability of the owner to limit the master's authority, or upon a construction of the charter in question. If the former, the case stands substantially alone; if the latter, it is opposed to the great weight of authority. See *The H. B. Foster*, 3 Ware, 165, Fed. Cas. No. 6,291; *Rozo v. The Neversink*, Fed. Cas. No. 12,079; *The India* (D. C.) 14 Fed. 476; *Id.* (C. C.) 16 Fed. 262. The language of some of the opinions last cited is not

clear, but the learned judges who delivered them did not mean to hold that a materialman could claim a lien for supplies furnished a vessel where he knew that the person ordering the supplies was expressly forbidden to permit the vessel to become bound for them.

That a chartered vessel is ordinarily bound for the price of supplies ordered for her use in a foreign port by the master was expressly decided in this circuit in the case of *The Philadelphia*, and this is the law where the charter is silent upon the subject. Where, however, the charter limitation is that found in this case, and where the coal is ordered, not in a port of distress, where it may reasonably be supposed that the further prosecution of the voyage is for the interest of the owner as well as for that of the charterer, I am of opinion that no lien exists.

Libel dismissed.

HUDSON et al. v. WOOD et al.

(Circuit Court, W. D. Kentucky. January 3, 1903.)

1. FEDERAL COURTS—PROCEEDINGS FOR ENFORCEMENT OF JUDGMENT—STATUTE GIVING BENEFIT OF STATE REMEDIES.

Rev. St. § 916 [U. S. Comp. St. 1901, p. 684], which provides that a party recovering a judgment in any common-law cause in a federal court "shall be entitled to similar remedies on the same, by execution or otherwise, to reach the property of the judgment debtor, as are now provided in like causes by the laws of the state," etc., does not embrace remedies in equity by independent suit which may have been given by the statutes of a state, but is limited by the phrase "in like causes" to remedies provided in actions at law wherein judgments were recovered.

2. SAME—CREDITORS' SUIT—ENFORCEMENT OF LEGAL DEMANDS IN EQUITY.

In a creditors' suit in a federal court by a judgment creditor against the judgment defendant and another, alleged to be his debtor on a mere money demand, the question of the latter's indebtedness, if denied by him, cannot be tried, even though such procedure is authorized by a state statute, since that would deprive him of his constitutional right to a jury trial; but the complainant may, by the joinder of such defendant, obtain a discovery from him as to his indebtedness and the right to an equitable lien thereon, to become effective and to be enforced when such indebtedness shall have been established in an action at law, and also the appointment of a receiver, with authority to bring such an action.

3. EQUITY—BILL FOR DISCOVERY—SUFFICIENCY.

A defendant in a creditors' suit, from whom discovery is prayed in respect to his indebtedness to the judgment debtor, cannot object to the making of such discovery because the bill waives answer under oath.

4. SAME—MULTIFARIOUSNESS.

A creditors' bill in a federal court, against judgment debtors and another who is alleged to be indebted to them on a legal demand, is multifarious, as against the latter, where it prays, not only for a discovery and for a decree adjudging a claim made by him that his indebtedness was to another than the judgment debtors to be fraudulent, but also for a personal judgment against him, as uniting equitable and legal demands, and because the latter is a demand over which the court is without jurisdiction in equity.

In Equity. On demurrer to bill.

Dodd & Dodd and Joseph Fettretch, for complainants.

Fairleigh, Straus & Eagles, Helm, Bruce & Helm, and Humphrey, Burnett & Humphrey, for defendant Boyle.

EVANS, District Judge. In an action at law lately pending in this court the complainants, C. I. Hudson & Co., who are citizens of New York, recovered a judgment against Geo. T. Wood, George L. Bacon, and Cary H. Bacon, individuals who composed the partnership firm of Geo. T. Wood & Co., brokers doing business in Louisville, for \$81,029.70, besides interest and costs, but subject to a credit of \$1,071.37. Subsequently an execution of fieri facias was issued by the clerk and placed in the hands of the marshal, by whom it was returned nulla bona. Afterwards this suit in equity was instituted by the judgment creditors against Geo. T. Wood, George L. Bacon, and Cary H. Bacon, partners as Geo. T. Wood & Co., St. John Boyle, and a corporation styled Geo. T. Wood & Co., all of whom are citizens of Kentucky. The bill of complaint, after alleging the foregoing facts and stating that the members of said partnership firm—the judgment debtors—each had in his possession or under his control money or securities therefor, or other equitable interests, etc., not subject to execution, and which they refused to surrender in payment of the judgment, contains averments as follows:

“(4) Plaintiffs state that they are informed and believe and charge that the defendants George T. Wood, George L. Bacon, and Cary H. Bacon, partners as George T. Wood & Co., hold as an asset a claim against the defendant St. John Boyle for at least the sum of \$81,029.70, with interest thereon from May 10, 1901, originating from the undertaking of the said St. John Boyle, as their undisclosed principal, to supply them, as his agents, with funds sufficient to pay off and discharge the said liability in favor of these plaintiffs against them; that the said indebtedness from the said George T. Wood & Co. to these plaintiffs arose and was created for the account and benefit of the said St. John Boyle as principal, in transactions wherein he employed the said George T. Wood & Co. as his agents, and that in executing his instructions and performing their duties as such agents the said George T. Wood & Co. incurred the said liability to plaintiffs. Plaintiffs state that it was the duty of the defendant St. John Boyle to supply the said George T. Wood & Co. with money sufficient to pay the said liability, and that he was and is legally bound to indemnify and pay them the amount of the said debt, interest, and costs. Plaintiffs state that they are informed, believe, and charge that the defendant St. John Boyle has undertaken, agreed, and promised to pay the said George T. Wood & Co. the money necessary to pay the said entire liability to plaintiffs, but has wholly failed and neglected to do so; that the said claim against St. John Boyle is an asset held by the said George T. Wood & Co., the proceeds of which, when and to the extent collected, should in equity and good conscience be applied on the plaintiffs' said judgment.

“(5) Plaintiffs further state that they are now informed that the defendants George T. Wood, George L. Bacon, and Cary H. Bacon, and the defendant St. John Boyle, claim that a pretended corporation was formed under the general laws of Kentucky in the early part of 1901 in the corporate name of George T. Wood & Co., and in which the defendants George T. Wood, George L. Bacon, and Cary H. Bacon were the sole incorporators, and equally interested as stockholders; that said corporation was formed to take over the assets and liabilities of the said firm of George T. Wood & Co.; and that the said defendants are now pretending that the claim asserted against the defendant St. John Boyle, in the fourth paragraph hereof, as aforesaid, is due to the said corporation of George T. Wood & Co., and not to the said firm of George T. Wood & Co. Plaintiffs state that during all the times hereinbefore set out, and when the said indebtedness was incurred to them by George T. Wood & Co., and created by the said St. John Boyle to the said George T. Wood & Co., the business of the said George T. Wood & Co. was conducted and carried on under the firm name of George T. Wood & Co., and under the

firm name of Wood, Bacon & Co., both of which firms, as well as the said pretended corporation, was composed of the said George T. Wood, George L. Bacon, and Cary H. Bacon alone, and all of the business in which the said George T. Wood & Co. was interested was carried on in the same office, by the same parties, as proprietors, bookkeepers, and employés, and with all of the same appliances. Plaintiffs aver that they are informed, believe, and charge that the said pretended claim that the account against said St. John Boyle belonged to the said corporation of George T. Wood & Co., instead of the firm of George T. Wood & Co., is a false and fraudulent device and pretense; that neither the said firm nor the said corporation has ever paid any part of the said judgment, nor have the said corporation any title, claim, or interest against the said St. John Boyle on account of said judgment indebtedness. Plaintiffs make the said George T. Wood & Co., Incorporated, a party hereto, and call it to answer and assert any claim or equity it may have to any of the assets sought to be subjected to the payment of the plaintiffs' judgment, or be forever barred therefrom."

After other averments not material to the matters now in hand, relief is prayed in this language:

"(7) In consideration of the premises, and forasmuch as the plaintiffs are without any adequate remedy at law, and cannot have adequate relief except in a court of equity, and to that end that the defendants, George T. Wood, George L. Bacon, Cary H. Bacon, Geo. T. Wood & Co., Incorporated, and St. John Boyle, may, if they can, show why the plaintiffs should not have the relief to which they are entitled, and for which they pray, and that the said defendants shall make full disclosures and discoveries of the assets and matters herein alleged as to each of them, so that same may be subjected to the plaintiffs' judgment, and that the said defendants, according to their and each of their best knowledge, remembrance, information, and belief make full, true, direct, and perfect answers to the matters herein stated and charged against them, respectively, but not under oath, their oaths being hereby expressly waived, the plaintiffs pray as follows: (1) That the said George T. Wood, George L. Bacon, and Cary H. Bacon, and each of them, be compelled to disclose and surrender to the court herein all money and securities therefor, choses in action, and legal and equitable assets in their possession or under their control and not exempt to them by law, to the end that the same shall be applied, under proper orders of this court, to the satisfaction of plaintiffs' judgment herein, and that the net proceeds arising therefrom be turned over to plaintiffs and applied as credits on their said judgment. (2) That the plaintiffs, in the name of said George T. Wood & Co., recover of the defendant St. John Boyle the sum of \$81,029.70, with interest thereon from May 10, 1901, and their taxable costs as to the said Boyle incurred and expended herein, so that the net proceeds of such recovery, when and as collected, shall be applied on said judgment against the said George T. Wood & Co., so far as may be necessary to pay the same. (3) That the defendant George T. Wood & Co., Incorporated, be adjudged to have no interest or claim in any of the aforesaid assets, or any assets discovered and disclosed herein, until the plaintiffs' said judgment, interest, and costs shall have been first satisfied. (4) That the plaintiffs may have such other and further appropriate relief in the premises as the nature of the case may demand, as equity may require, and as to this court may seem proper, to the end that may be necessary to enforce the plaintiffs' aforesaid judgment, interest, and costs."

No objection to the proceeding is taken by any of the defendants, except Boyle, who has interposed a demurrer to the bill upon three distinct grounds, to wit: (1) That this court has no jurisdiction of the alleged complaint; (2) that the bill is multifarious; and (3) that the bill does not contain any matter of equity whereon the court can ground any decree or give the complainants any relief against the defendant Boyle. The questions thus raised have been ably argued, and an effort to find a proper solution of them has required no little

labor. While at first impression they may seem to present nothing troublesome, the more they have been considered the more difficulties have multiplied, mainly because of the paucity of exactly applicable and instructive authority.

2. For the demurrant it is insisted (1) that the bill is multifarious; (2) that in reality it is, under some disguises, an action at law to recover, in complainants' names, but for the benefit of Geo. T. Wood & Co., as well as themselves, a money judgment against Boyle upon a mere legal demand, all issues in respect of which he has a constitutional right to have tried in a court of law; and (3) that the bill presents a cause of action upon a legal demand by the complainants as assumed assignees of Geo. T. Wood & Co., or as persons equitably entitled to be such, of their debt against Boyle, and that, as all the defendants are citizens of Kentucky, this court is without jurisdiction, not only because the remedy at law against Boyle is plain, adequate, and complete, but also because an assignee of a chose in action cannot sue at all in the federal courts unless his assignor could have done so,—two legal conclusions about which there could be little controversy if the premises be correct. *New York Guaranty & Indemnity Co. v. Memphis Water Co.*, 107 U. S. 214, 2 Sup. Ct. 279, 27 L. Ed. 484. However, the contention need give little or no trouble, as there seems to be no substantial basis for the idea of an assignment, nor, indeed (as we may take this occasion to say), for the contention that the facts stated in the bill respecting the origin and nature of the claim against Boyle show any equitable interest therein in favor of the complainants.

By the complainants it is insisted, among other things, that under section 916 of the Revised Statutes of the United States [U. S. Comp. St. 1901, p. 684] they have the right to all the processes and remedies provided by the Civil Code of Practice of Kentucky for subjecting to their claim any indebtedness due to their judgment debtors. That section is in this language:

"The party recovering a judgment in any common-law cause in any circuit or district court shall be entitled to similar remedies upon the same, by execution or otherwise, to reach the property of the judgment debtor, as are now provided in like causes by the laws of the state in which such court is held, or by any such laws hereafter enacted which may be adopted by general rules of such circuit or district court; and such courts may, from time to time, by general rules, adopt such state laws as may hereafter be in force in such state in relation to remedies upon judgments, as aforesaid, by execution or otherwise."

When sections 5595 and 5596 of the Revised Statutes [U. S. Comp. St. 1901, p. 3750], which relate to the revision of the Statutes completed in 1873, were enacted, section 916 appeared in its present form for the first time, although in substance it was contained in the judiciary act of 1789. Sections 915 and 916 are adaptations of the provisions of section 6 of "An act to further the administration of justice," approved June 1, 1872 (17 Stat. 197). By its terms section 916 gave to parties "recovering judgments at law" in the federal courts similar remedies upon the same "by execution or otherwise" to reach the property of the judgment debtor as was then provided in "like causes" by the laws of the state where the court is held, or

by any law subsequently enacted which might be adopted by a rule of the court. As no such rule has been adopted by this court, we are remitted to the laws of Kentucky in force either on June 1, 1872, when the act of 1872 was approved, or to those in force on December 1, 1872, pursuant to section 5595, Rev. St. In this case it is immaterial which date we take, because the laws of Kentucky having any application were precisely the same at each of them. Those laws are to be found in sections 474 to 478, inclusive, of Myers' Code, and to them more explicit attention will be called further along.

Construed in reference to the maxim "ejusdem generis," there would, even in the absence of authority, be great doubt in the mind of the court whether section 916, Rev. St., embraces remedies in equity at all, or whether its provisions are not limited and confined to legal remedies, such as the old writs of fieri facias, mandamus, and the like, and to any other legal process or remedy which the states may invent or bring into vogue. These doubts are increased when we read section 6 of the act of 1872, and carefully analyze the words of that section in connection with the maxim referred to. Nor are they diminished when we reflect that the constitution itself has made it essential that great care should be taken to keep separate and distinct the respective remedies at law and in equity. *Fenn v. Holme*, 21 How. 484, 16 L. Ed. 198; *Bennett v. Butterworth*, 11 How. 669, 13 L. Ed. 859. Only "judgments at law" are in terms referred to in the section, and the remedies made available in this court by it are such as are provided by the laws of Kentucky "in like causes" by "execution or otherwise." The United States having no common law of its own in 1789, and no general Code of Practice being desirable, congress, which has the exclusive power to regulate practice in the national courts, no doubt concluded that it was not only appropriate, but essential, for it to authorize the courts of the United States in actions not equitable to use such remedies and writs as were used "in like causes"—that is, actions at law wherein judgments were recovered—in the states where the court sat. But while this, at that early date, gave the courts ample powers in actions at law, it was not meant, as it seems to us, and as will, we think, be clearly shown by the authorities, to affect, in any manner, remedies in equity, which were to be governed by other rules. Indeed, the court has industriously, but in vain, searched for authority which shows the applicability of section 916 to remedies in equity, and it may be more than doubted whether the power to use as equitable those remedies which are essentially remedies at law can be bestowed by state legislation upon the federal courts, although it is clear enough that, if any new rights which are equitable in their nature be conferred by state legislation, they may be made available in the federal courts, if it can be done pursuant to the modes of equity procedure established by the supreme court or by federal laws, or even in some instances by state laws, where the right and the remedy are practically the same things. *Gormley v. Clark*, 134 U. S. 348, 10 Sup. Ct. 554, 33 L. Ed. 909, and cases collected in 8 Notes U. S. Rep. 464, 465. But this in no wise depends upon section 916.

Many authorities were cited by counsel, which were supposed to

have some bearing on the question. We will only notice some of the more important of them.

In *Ex parte Boyd*, 105 U. S. 647, 26 L. Ed. 1200, the petitioner had been sued at law by the United States in the district court for the Southern district of New York, and judgment had been rendered against him. After an execution had been returned not satisfied, it was ordered by the court in that case, pursuant to a law of New York providing for proceedings suppletory to a writ of *feri facias*, that the matter be referred to a commissioner of the court to examine Boyd under oath touching his property, etc., and Boyd was ordered to appear for such examination. When he appeared he refused to take an oath, and was attached for the contempt. He thereupon sued out a writ of *habeas corpus* to test the validity of his imprisonment, and this question and whether he was entitled to be released were the subjects of the court's consideration. After an elaborate discussion of them, and particularly as affected by section 916, Rev. St., the supreme court held that the discharge of the petitioner was properly refused. As bearing upon the proceeding in this case, the significance of what the court said at pages 656, 657, 105 U. S., cannot be overlooked. Its language was:

"But here we have nothing to do with any question but that of discovery. The only relief sought is knowledge of property belonging to the debtor applicable, either at law or in equity, to the payment of the creditor's judgment. What shall be done, after that knowledge has been acquired, is to be determined upon the circumstances as they may then appear, and cannot now be considered. For the proceeding for discovery is distinct and entirely separable from the subsequent relief, if any shall then be sought."

In *Willard v. Wood*, 135 U. S. 309, 10 Sup. Ct. 831, 34 L. Ed. 210, the plaintiff, a mortgagee, brought an action at law in the supreme court of the District of Columbia to recover from the grantee of the mortgaged premises the amount of the mortgage debt, which, as part of the purchase money, he had covenanted with the mortgagor to pay to the mortgagee; but the supreme court of the United States on writ of error affirmed the judgment dismissing the action, because under the practice of the courts of the United States, especially in that district, the jurisdiction was exclusively in equity in such cases, as had been held in *Keller v. Ashford*, 133 U. S. 610, 10 Sup. Ct. 494, 33 L. Ed. 667. As the contract was between the mortgagor and his grantee, there was no privity between the latter and the mortgagee,—the plaintiff.

In *Cowley v. Railroad Co.*, 159 U. S. 569, 16 Sup. Ct. 127, 40 L. Ed. 263, a proceeding in equity had been instituted in a district court in Washington for obtaining a new trial of a case wherein a judgment had been procured by fraud in a suit brought and decided in the territorial court before the admission of the state. This proceeding was removed to the federal court, which dismissed it. The supreme court, in its opinion reversing this judgment, at page 582, 159 U. S., page 131, 16 Sup. Ct., and 40 L. Ed. 263, said:

"Although the statute of a state or territory may not restrict or limit the equitable jurisdiction of the federal courts, and may not directly enlarge such jurisdiction, it may establish new rights or privileges which the federal courts

may enforce on their equity or admiralty side, precisely as they may enforce a new right of action by statute upon their common-law side."

But evidently this had no reference to section 916.

In *Railroad Co. v. Hart*, 114 U. S. 654, 5 Sup. Ct. 1127, 29 L. Ed. 226, Hart recovered a judgment at law in the federal court against the city of New Orleans, and after a return of nulla bona filed in that action at law a supplemental petition, as authorized by the laws of Louisiana, alleging that, having reason to believe that the railroad company owed the city, he had caused a seizure of such indebtedness to be made in the hands of the company, and prayed that it might be cited to answer, and that any indebtedness found to exist might be subjected to his judgment. The street railroad company answered, explicitly denying any indebtedness to the city. Upon the issue formed a jury was impaneled as required by law, and after hearing the evidence it was found that the company was indebted to the city, and judgment was rendered accordingly. Upon a writ of error to the supreme court it was held, upon the authority of *Ex parte Boyd*, that the proceeding was admissible in the federal court under the provisions of section 916. At page 662, 114 U. S., page 1131, 5 Sup. Ct., and 29 L. Ed. 226, is found this language:

"The meaning of that section is that the remedies, by execution or otherwise, on a judgment in a common-law cause in a circuit court, shall be the same as were then provided by the laws of the state in respect to judgments in suits of a like nature or class. 'Like causes' is the expression. By article 641 of the Code of Practice of Louisiana, it was and is provided that, 'when the judgment orders the payment of a sum of money, the party in whose favor it is rendered may apply to the clerk and obtain from him a writ of fieri facias against the property of his debtor.' It is this provision, and the garnishee proceedings consequent upon it, provided by the laws of Louisiana in respect to judgments generally of a like nature or class with those in the present case, which the act of congress adopted as remedies for the judgment creditor in a common-law cause in the circuit court."

It will not escape notice that, like the *Boyd Case*, the *Hart Case* was an action at law wherein, by the laws of New York and Louisiana, respectively, that sort of supplementary proceeding or garnishment was allowed in actions at law, precisely as the writ of mandamus may issue in cases where it is appropriate as an ancillary remedy. None of these cases, however, fully reach the exact point to be determined on this hearing, any more than do such cases as uphold the right to resort to equity where there is a trust fund to be applied to debts, or where a judgment creditor has otherwise an equitable interest, more or less pronounced, in the thing sought to be subjected by equitable proceedings; and, as already indicated, it does not seem to the court that it can be maintained that complainants, upon the facts stated by them, have any such interest in the claim of *Geo. T. Wood & Co. against Boyle* as to bring this case within the decisions which relate to trust funds or equitable interests.

Another class of cases where equity may have jurisdiction upon principles allied to the trust fund doctrine may be regarded as represented by *Mann v. Appel* (C. C.) 31 Fed. 378. Nor is it doubted that by the institution of equitable proceedings in a proper case a complainant acquires a lien, as in *Commissioners v. Earle*, 110 U. S. 710, 4 Sup. Ct. 226, 28 L. Ed. 301, *Metcalf v. Barker* (Dec. 1, 1902) 23 Sup.

Ct. 67, 47 L. Ed. —, and also, as we shall see, in this case. But *Johns v. Wilson*, 180 U. S. 440, 21 Sup. Ct. 445, 45 L. Ed. 613, and *Insurance Co. v. Hanford*, 143 U. S. 187, 12 Sup. Ct. 437, 36 L. Ed. 118, are cases where certain matters of practice were discussed which bear too little resemblance to the case before us to render necessary a more particular statement of them.

For the defendant Boyle it is insisted that the principles announced in *Scott v. Neely*, 140 U. S. 106, 11 Sup. Ct. 712, 35 L. Ed. 358, must rule the questions now involved. There, in accordance with what might be done in a state court under the laws of Mississippi, a suit in equity was filed in the federal court sitting in that state to subject to the plaintiff's debt certain property of the defendant before there had been any judgment upon the demand. It was contended that, because the state allowed this remedy by an equitable action in her courts before a judgment at law had been obtained, it followed that the same remedy was available in equity in the courts of the United States; but the supreme court denied the proposition, and, among other things, said, at pages 109, 110, 140 U. S., page 713, 11 Sup. Ct., and 35 L. Ed. 358:

"At the outset of the case the question is presented whether a suit of this kind, where the complainant is a simple contract creditor, can be maintained in the courts of the United States. It is sought to uphold the affirmative of this position on the ground that the statute of Mississippi creates a new equitable right in the creditor, which, being capable of assertion by proceedings in conformity with the pleadings and practice in equity, will be enforced in those courts. The cases of *Clark v. Smith*, 13 Pet. 195, 10 L. Ed. 123; *In re Broderick's Will*, 21 Wall. 503, 22 L. Ed. 599, and *Holland v. Challen*, 110 U. S. 15, 3 Sup. Ct. 495, 28 L. Ed. 52, are cited in its support. The general proposition as to the enforcement in the federal courts of new equitable rights created by the states is undoubtedly correct, subject, however, to this qualification, that such enforcement does not impair any right conferred, or conflict with any inhibition imposed, by the constitution or laws of the United States. Neither such right nor such inhibition can be in any way impaired, however fully the new equitable right may be enjoyed or enforced in the states by whose legislation it is created. The constitution in its seventh amendment declares that 'in suits at common law, where the value in controversy shall exceed twenty dollars, the right of trial by jury shall be preserved.' In the federal courts this right cannot be dispensed with, except by the assent of the parties entitled to it; nor can it be impaired by any blending with a claim properly cognizable at law of a demand for equitable relief in aid of the legal action or during its pendency. Such aid in the federal courts must be sought in separate proceedings, to the end that the right to a trial by a jury in the legal action may be preserved intact."

Here, indeed, was a case where the remedy in equity was held not to be available in the federal courts, though it was so in the state courts. That case, therefore, while a satisfactory authority upon the proposition that state laws can never regulate the mere equity practice of the federal courts, and also, as we shall see, a most important authority upon the contention that Boyle is entitled to a trial by a jury in an action at law, is not an authority upon the construction of section 916, Rev. St., for the reason that there had been no "recovery of a judgment at law," and the case, therefore, did not come within the language of that section.

Smith v. Bourbon Co., 127 U. S. 110, 8 Sup. Ct. 1043, 32 L. Ed. 73, is also cited by the defendant. It is a case where a judgment creditor

of a railroad company brought suit in equity for the purpose (1) of compelling the railroad company to assign to him its claim against the county for bonds agreed to be issued by it for stock of the railroad company, and (2) of compelling the county commissioners to issue the bonds and deliver them to the complainant to the extent of his judgment. The supreme court held that the latter right was not an equitable, but a legal, right, to be enforced by mandamus; and while, therefore, directing the retention of the bill as to the first right claimed, it adjudged as to the second that the bill should be dismissed for want of jurisdiction in equity. All of this, however, was done upon considerations which do not appear to have any direct bearing upon the questions now before us.

If we assume that section 916 applies to this case in equity, notwithstanding the difficulties we have endeavored to point out, the inquiry will be as to what is the remedy by "execution or otherwise" provided in such a case by the laws of Kentucky. As already indicated, the applicable provisions of the Kentucky Code of Practice in force in 1872 are to be found in Myers' Code in these words:

"Sec. 474. After an execution of fieri facias, directed to the county in which the judgment was rendered, or to the county of the defendant's residence, is returned by the proper officer, either as to the whole or part thereof, in substance, no property found to satisfy the same, the plaintiff in the execution may institute an action, by equitable proceedings, in the court from which the execution issued, or in the court of any county in which the defendant resides, or is summoned, for the discovery of any money, chose in action, equitable or legal interest, and all other property to which the defendant is entitled, and for subjecting the same to the satisfaction of the judgment; and in such actions, persons indebted to the defendant in the execution, or holding the money or property in which he has an interest, or holding the evidences or securities for the same, may be also made defendants.

"Sec. 475. The answers of all the defendants shall be verified by their own oath, and not by that of an agent or attorney, and the court shall enforce full and explicit discoveries, in such answers, by process of contempt.

"Sec. 476. In the action mentioned in the preceding sections, the plaintiff may have an attachment against the property of the defendant in the execution, similar to the general attachments provided for in chapter three, of title eight, without either the affidavit or bond therein required.

"Sec. 477. A lien shall be created on the property of the defendant, by the levy of the attachment, or service of the summons, with the object of the action indorsed thereon, on the person holding or controlling his property.

"Sec. 478. The court shall enforce the surrender of the money, or securities therefor, or of any other property of the defendant in the execution which may be discovered in the action, and, for this purpose, may commit to jail any defendant or garnishee failing or refusing to make such surrender, until it shall be done, or the court is satisfied that it is out of his power to do so."

Manifestly, in terms, those sections only provide for the institution "of an action, by equitable proceedings," in which certain specified things may be done. We may well doubt whether the equitable proceeding thus provided for can be made available in the federal courts when in the opinion of the supreme court in the case of *Boyle v. Zacharie*, 6 Pet. 658, 8 L. Ed. 527, we read the following language:

"The chancery jurisdiction given by the constitution and laws of the United States is the same in all the states of the Union, and the rule of decision is the same in all. In the exercise of that jurisdiction, the courts of the United States are not governed by the state practice; but Act Cong. 1792, c. 36, has

provided that the modes of proceeding in equity suits shall be according to the principles, rules, and usages which belong to courts of equity, as contradistinguished from courts of law. And the settled doctrine of this court is that the remedies in equity are to be administered, not according to the state practice, but according to the practice of courts of equity in the parent country, as contradistinguished from that of courts of law, subject, of course, to the provisions of the acts of congress and to such alterations and rules as in the exercise of the powers delegated by those acts the courts of the United States may from time to time prescribe."

And the following from the opinion of the court in *Payne v. Hook*, 7 Wall. 425, 19 L. Ed. 260, is equally strong. It is there said:

"We have repeatedly held 'that the jurisdiction of the courts of the United States over controversies between citizens of different states cannot be impaired by the laws of the states, which prescribe the modes of redress in their courts, or which regulate the distribution of their judicial power.' If legal remedies are sometimes modified to suit the changes in the laws of the states and the practice of their courts, it is not so with equitable. The equity jurisdiction conferred on the federal courts is the same that the high court of chancery in England possesses, is subject to neither limitation nor restraint by state legislation, and is uniform throughout the different states of the Union."

Nothing can be clearer than that such is still the "settled doctrine of the court"; but we must disregard it if we hold that section 916, in its scope and purpose, embraces equitable actions. Such a course is by no means open to this court, as appears even more clearly when we read section 913, Rev. St. [U. S. Comp. St. 1901, p. 683].

Until ruled otherwise by the circuit court of appeals of this circuit in the case, cited and relied upon by the complainants, of *Phelps v. Association*, 50 C. C. A. 339, 112 Fed. 456, it was supposed to be settled, under the express authority of the opinion of the court of appeals of Kentucky in the case of *Davidson v. Simmons*, 11 Bush, 333, that not a suppletory proceeding in an action at law, but an independent and separate suit in equity, was the only sort of suit that could be brought in the state court upon a judgment under the law and practice of Kentucky. In the *Phelps Case* the plaintiff in an action at law in the state court had procured a personal judgment; an execution, and a return of *nulla bona*. Long after the time when that court had ceased to have any control over the case under the Kentucky law, the plaintiff, without notice to the defendant, filed or attempted to file an amended petition in the nature of a petition in equity in that suit at law, and thereupon the case was attempted to be transferred to the equity docket by an order to that effect also made without notice. After that was done, but still without notice, the court appointed a receiver for the defendant's property. When the receiver thus appointed attempted to get possession of the defendant's property, the latter filed its bill of complaint in this court, wherein it prayed for an injunction against his doing so. This was granted upon the ground that the state court had no right or jurisdiction to act in the premises, that the appointment of the receiver under those circumstances was utterly void, and, that being so, he was a trespasser, who had no more right than any other citizen to take possession of the property of the association. 103 Fed. 515. Upon appeal this judgment was reversed by the circuit court of appeals (50 C. C. A. 339, 112 Fed. 456), and the

case is now pending in the supreme court, where it must be determined, not whether such proceedings as occurred or were attempted in the state court would have been admissible under the general equity practice of courts of the United States, but whether they were void under the practice established by the state of Kentucky for the government of her courts. In other words, as the point there involved is practically the converse of that raised here, to wit, what was proper practice in the common-law action in the state court, the most interesting question to be decided by the supreme court on the appeal would seem to be this: Can the federal courts, under section 720, Rev. St. [U. S. Comp. St. 1901, p. 581], or otherwise, properly hold that an attempted proceeding in a state court in an action at law previously pending therein, but which had long before expended its force and died from exhaustion, and over which the state court had long before lost control, and which attempted proceeding in the common-law action was void under the state law as being outside of the power and jurisdiction of the courts of the state under its laws and practice, must nevertheless be treated as valid by the federal courts, because the attempted proceeding might be justifiable upon the general principles of equity or other practice in the courts of the United States or of states other than that wherein the common-law action had been instituted, and upon this latter test, rather than the former, to determine the validity of the action of the state judge in appointing a receiver without notice in a proceeding not at the time pending in his court? The opinion of the circuit court of appeals is, of course, binding upon this court; but this statement of the case has been made to clearly show that, while the researches of the learned judge who rendered the opinion throw most valuable light upon equity practice generally, that opinion cannot be regarded as construing section 916, Rev. St., which, indeed, does not seem to have been mentioned.

But, without going further into this phase of the case, it seems to the court, after a very attentive consideration of the subject, that while section 916, Rev. St., applies to remedies and actions at law, congress never intended by that legislation to adopt to any extent the mere equity practice of the states. Otherwise, instead of being uniform throughout the United States, the federal equity practice should be conformed to the various and discordant local laws. Strong support is also given to this conclusion by the opinion of Judge McAllister in Fed. Cas. No. 2,266 (*Byrd v. Badger*, 4 Fed. Cas. 942). If, however, we assume the contrary, we shall not, except in the one essential feature presently to be noticed, reach results very different from those which come from the established equity practice of the United States. To a very great extent the practice, or, at all events, the rights of judgment creditors are essentially the same in both jurisdictions. Respecting the provisions of Kentucky law embraced in Myers' Code, and covering sections 474 to 478, inclusive, the court of appeals of Kentucky has held that "the action by equitable proceeding" mentioned in section 474 is the only sort of suit that can be brought on a judgment in this state. *Davidson v. Simmons*, 11 Bush, 333. In other words, that court, in construing the Kentucky law, holds that that is the only supplementary proceeding authorized where there has

been a personal judgment and a return of *nulla bona*. The Code expressly provides for the creation of a lien either by an attachment or the service of a summons with the indorsement thereon of the object of the suit. The Code also provides that persons owing the judgment debtor may be made defendants in the action. This, then, is the equitable procedure established by the state of Kentucky. It is by an independent action, and the remedy is exclusive of all others which seek to subject equitable assets to a judgment. *Davidson v. Simmons*, *supra*. By the procedure thus authorized the laws of the state of Kentucky provide a means for subjecting to judgment debts the intangible assets of the debtor. A failure to provide some means to subject that class of property to the payment of debts would be a just reproach to the legislation as well as the jurisprudence of the state. Kentucky's way of doing it is prescribed by the Code provisions referred to. While that mere procedure for doing it cannot be, and, as I think, has not been, imposed upon the equity practice of the federal courts, we shall find, we think, that, except in one essential respect, it differs only in detail from what is available here. There are certain cases under the Kentucky Code where, if a debtor of the judgment debtor is made a defendant in the suit in equity authorized by the Code, and if in the petition the indebtedness is clearly stated and identified, a personal judgment for the amount may be rendered against him in that suit in favor of the judgment creditor, with an injunction against its collection by the judgment debtor. *Joyce v. O'Toole*, 6 Bush, 32. This can be done if the indebtedness is not disputed; but, if there is a denial of the indebtedness, all that the plaintiff acquires at this point in his suit is an equitable or *pendente lite* lien upon the demand. The Code, however, apparently stops short of providing, at least in express terms, for any further proceeding in case the alleged indebtedness is disputed. In such contingency no positive provision of the Code meets the case. In this connection the Kentucky practice is not altogether clear, and the complainants might soon be, if, indeed, they are not now, confronted with that difficulty if the Kentucky Code provisions are applicable to their case.

But, passing this, it may be said that, while upon demurrer to the bill of complaint the well-pleaded averments are taken as true, it cannot be fairly claimed that the statements of this bill explicitly or clearly show an indebtedness by Boyle to the judgment debtors. On the contrary, it shows that several questions must be settled before the conclusion can be reached that he in fact owes it to them, instead of the different entity known as the Geo. T. Wood & Co. corporation. Can this question, as against Boyle, be settled in an equity cause, or must it be determined by a suit at law? These are most essential inquiries, and bring us to the point where we must determine the exact rights of the complainants upon established principles of legal, as well as equity, practice and the allegations of their bill of complaint. This, we think, it is not difficult to do. It has long been the practice for a creditor, who has exhausted his remedies at law by procuring a personal judgment and an unavailing execution, to file what has always been called a "creditors' bill" to obtain from his debtor a discovery of his assets and for the subjection thereof to the payment of the judg-

ment. The relief thus sought can be obtained by compelling the debtor to surrender to the court such of his property as he has in his possession or under his control, and, if necessary, by the appointment of a receiver, with authority to sue for and collect any demands or choses in action that may be due to the judgment debtor. High, Rec. § 99 et seq.; 6 Enc. Pl. & Prac. 593, 466. Doubtless a lien (sometimes called an "equitable levy") can be had upon the choses in action by making the persons from whom they are due parties to the bill (*Commissioners v. Earle*, 110 U. S. 710, 4 Sup. Ct. 226, 28 L. Ed. 301); but the action of the parties to the previous action at law in which a judgment was rendered, on the one hand, and the appointment of a receiver and the authority given him on the other, cannot and should not affect the rights of any third person, even if he is a debtor of the judgment debtor. The rights of such third person cannot be lessened or injured by the matters referred to. In short, his rights, especially that of having a jury pass upon his case, cannot in any manner be impaired or taken from him by any contention or proceeding between the judgment creditor and the judgment debtor. Nor is the force of these suggestions lessened by the fact that, if such party is duly impleaded, the judgment creditor may secure an equitable lien upon whatever he may owe the judgment debtor, when that question, if controverted, shall have been settled or adjudicated at law. The process by which such a lien is properly created is a species of garnishment, because it is a warning to the third party not to pay anything he owes except as the court orders; but it in no way undertakes to settle any points of controversy about the alleged debt between the third party and his alleged creditor.

3. It may be technically true that the bill in this case, in the strict sense, is lacking in some of the qualities of a bill of discovery, because answers under oath are waived (*Huntington v. Saunders*, 120 U. S. 80, 7 Sup. Ct. 356, 30 L. Ed. 580); but it is certainly a creditors' bill, and we doubt if the objection is one with which Boyle is concerned on the hearing of the demurrer, especially as the bill only states argumentatively, and not positively, that he is indebted to the judgment debtors, and as he cannot be prejudiced by not being required to answer under oath as to whether he is indebted to the judgment debtors. If the latter waive the objection, and make discovery of demands due them, or of other assets belonging to them, such assets, if available for complainants at all, would be quite as much so under those circumstances as if answer under oath had not been waived. No one but themselves is bound by their answers. Other defendants may answer as advised; but, if Boyle really owes the judgment debtors, such indebtedness, when properly ascertained, may be subjected to their judgment in this proceeding, and, if Boyle is protected against a second demand for it, it is quite immaterial to him who gets the money when it is paid by him. If Boyle should answer, admitting the indebtedness, he would be but little concerned about the future proceedings; but whether his answer, if he made one denying all indebtedness to the judgment debtors, would, at least for the present, be conclusive in this action, is not a question which can now be determined, although it is one about which the authorities greatly differ. But,

assuming that it should not be so regarded, his contention is that neither under the Kentucky law nor under the equity practice of this court can the question of his liability to the firm of Geo. T. Wood & Co. upon a purely legal demand be determined in this suit in equity, where he has no right to have the matter tried by a jury. Undoubtedly, if he disputes it, the question of whether he owes the money to them is one of purely legal cognizance. The remedy at law upon such a demand is plain, adequate, and complete. In any controversy with them respecting it, is he not, at least in this court, whatever might be the case under the Kentucky Code, by manifest constitutional right, entitled to have the issue tried by a jury and not left to the mere discretion of the judge as to framing an issue to be tried out of chancery? Under the seventh article of amendments to the constitution of the United States the answer to the question is obvious. Can this constitutional right be affected or altered by the fact that he might owe, or be said to owe, money to the complainants' debtors? We think certainly not. The doctrine upon which cases like *Scott v. Neely*, 140 U. S., 11 Sup. Ct., 35 L. Ed., proceeds is largely that a creditor cannot, by going into equity in the first instance, deprive a defendant of his constitutional right of having the issues upon a purely legal demand tried by a jury in the common-law tribunals of the United States; and the reach of that doctrine clearly embraces cases like this, because it cannot be that a defendant situated like Boyle should more easily be deprived of that right than would be a defendant situated like the one in *Scott v. Neely*. So that, if the Kentucky Code applies, it must be subject to that qualification. Hence the inquiries just suggested must be answered in the negative, and it must result that the only rights the complainants have in this action against Boyle are the right to an answer from him as to whether he is indebted to the judgment debtors or either of them, and the right to an equitable lien ("equitable levy," as it is sometimes called) upon any indebtedness of his to the judgment debtors, such lien to become effective and to be enforced when such indebtedness, if denied, shall have been ascertained in an action at law. One essential step in the effectuation of such a lien or levy in this suit, to which both Boyle and said judgment debtors are parties defendant, if Boyle denies indebtedness, is to appoint a receiver, clothed with authority, in his own name jointly with that of the judgment debtors, to sue for and collect the indebtedness, if any, due to said judgment debtors, the proceeds to be accounted for by him in this suit. These results cannot be affected or changed by the allegations in the bill that Boyle is fraudulently claiming that his indebtedness, if any, is to the corporation, and not to the judgment debtors, because the suit at law by the receiver would develop whether or not he owes the judgment debtors, and, if he did not, then that phase of this suit might be ended, or such ulterior steps taken as might be proper.

4. It is also contended that the bill is multifarious. Courts in modern times have not been so strict as formerly in enforcing this objection, but have not hesitated to do so in cases plainly demanding it. When the bill in this case is analyzed and given the most liberal construction, it will be found to seek (1) a discovery of assets from the

judgment debtors, (2) a personal judgment against the defendant Boyle upon a mere money demand alleged to be due from him to the judgment debtors, and (3) a decree that the alleged pretense by Boyle that any indebtedness from him in the premises is due to the corporation defendant, and not to the judgment debtors, is fraudulent. In the opinion of the court it has jurisdiction of the bill for the purpose of discovering the assets of the judgment debtors and for subjecting them to the judgment of the complainants. The court is also of opinion that there is matter in the bill sufficient to support a decree, under the prayer for general relief, for the taking of all necessary steps competent in a proceeding in equity to accomplish the two objects just indicated, and consequently that the demurrer to the bill upon those grounds and to that extent should be overruled and disallowed. As this is a creditors' suit, large latitude should be permitted, particularly as against judgment debtors, even if it does verge upon multifariousness; but it nevertheless seems to the court to be very clear that the bill goes beyond allowable limits as against Boyle. The peculiar aspect given to the bill will make it necessary, if the court fully grant its prayers, (1) to enforce a discovery as against the judgment debtors, (2) to adjudge that the alleged pretense of Boyle that his creditor is the corporation and not the partnership is fraudulent, and (3) to render a personal judgment against Boyle in favor of the complainant, although there is no privity between them. So that the court must take three or more distinct steps, some of a legal and others of an equitable nature, to afford the complete relief asked. Viewed from the standpoint of the complainants and their debtors, that fact might raise no insuperable difficulty; but the strict rights of Boyle are those which we must determine under the stress of his demurrer. As already indicated, it seems to the court that even as to him the action is well brought, so far as it seeks a discovery of assets of the judgment debtors and their subjection to complainants' demand, and also for acquiring an equitable lien or levy upon such assets, including any indebtedness of Boyle to the judgment debtors, but that the character of the specific relief sought against Boyle in the second prayer of the bill makes that pleading multifarious, and not only so, but as to that part of the relief sought the court is without jurisdiction in equity.

Upon those grounds and to that extent the demurrer to the bill is allowed and sustained, and, following the practice suggested by the action of the court in *Smith v. Bourbon Co.*, 127 U. S., 8 Sup. Ct., 32 L. Ed., the bill should be dismissed as to that part of the relief sought and retained as to the others; but, in view of the intimate connection between what is sought by prayer No. 2 and prayer No. 3, it seems proper that all further proceedings in the case as to the latter should be suspended until there has been opportunity to settle, either in a court of law or by the agreement of the parties, the question of who is the creditor of Boyle in respect to the transactions alluded to in the fourth and fifth paragraphs of the bill. The complainants are given leave to so amend their bill as to remove the objections thereto pointed out in this opinion, and by omitting therefrom prayers for any relief against Boyle, except such as may be appropriate under the views herein expressed.

ELLIS v. JOHN CROSSLEY & SONS, Limited.

(Circuit Court, S. D. New York. January 6, 1903.)

1. VENDOR AND PURCHASER—FAILURE OF TITLE—LIMITED WARRANTY UNDER LOUISIANA STATUTE.

Under Code La. art. 2505, which provides that a vendor of lands, even in case of stipulation of no warranty, is liable to a restitution of the price in case of the purchaser's eviction, "unless the buyer was aware, at the time of the sale, of the danger of eviction, and purchased at his peril and risk," as construed by the courts of the state, a purchaser of a large quantity of land, who has full knowledge of defects in the title to a portion of it, and accepts a deed to such portion with a restricted warranty, must be held to have "purchased at his peril and risk" as regards that portion, and cannot recover from the vendor for his eviction therefrom.

2. SAME—GROUNDS FOR RECOVERY.

A purchaser of land cannot recover the purchase money paid in an action at law against his vendor, on the theory of an eviction merely, when he subsequently secured the issuance of a patent for the land from the United States which inured to his benefit.

3. SAME.

The mere fact that a commissioner of the general land office had the word "Canceled" written across the record of a patent, 55 years after its issuance, does not constitute an eviction of the person holding title and possession under such patent, so as to entitle him to recover from his vendor for a failure of title.

At Law. Action to recover from a vendor for failure of title to land.

This is an action to recover \$49,603 damages by reason of the failure of title upon the sale of certain lands, located in the state of Louisiana, which were conveyed by the defendant to the plaintiff's testator, in April, 1888, with a full warranty as to a part of the said lands and with a limited warranty as to the remainder. The cause was tried at the October term, held in the city of New York, before the court, a jury trial having been waived by stipulation, duly filed. At the close of the testimony the defendant moved generally for a dismissal of the complaint and also for a separate dismissal as to each of the several parcels of land in controversy, on the ground that the plaintiff had failed to prove facts entitling her to recover.

I. R. Oeland, for plaintiff.

Wheeler H. Peckham and Richard De Gray, for defendant.

COXE, Circuit Judge. In April, 1888, the defendant sold to Littleberry A. Ellis, plaintiff's testator, three plantations, situated on the Mississippi river, in the state of Louisiana. The lands in litigation are a part of the so-called "Riverside Plantation." Of these lands 365.39 acres were conveyed with a full warranty and 2,391.18 with a limited warranty: The plaintiff insists that as to this land, amounting to 2,756.57 acres in all, the title has failed and that she has been evicted therefrom.

Regarding the sale of lands under the so-called restricted warranty no case has been established. The sections of the Louisiana Code involved in this controversy are as follows:

"Art. 2500. Eviction is the loss suffered by the buyer of the totality of the thing sold or of the part thereof occasioned by the right or claims of a third person."

"Art. 2503. Parties may, by particular agreement add to the obligations of warranty which results of right from the sale, or diminish its effects; they may even agree that the seller shall not be subject to any warranty."

"Art. 2505. Even in case of stipulation of no warranty, the seller in case of eviction is liable to a restitution of the price, unless the buyer was aware at the time of the sale of the danger of eviction and purchased at his peril and risk."

"Art. 2514. In case of eviction from a part of the thing, the sale is not canceled, the value of the part from which he is evicted, is to be reimbursed to the buyer according to its estimation, proportionately to the total price of the sale."

Article 2505 has been construed by the courts of Louisiana to mean that the vendor is not liable where the infirmities of the title were known to the vendee, for in such circumstances the latter takes the property at his own risk. "Article 2505 means the same as if it read 'unless the buyer was aware, at the time of the sale, of the danger of the eviction and therefore purchased at his peril and risk.'"

The evidence is undisputed that Mr. Ellis had full knowledge of the defects in the title of these unwarranted lands. Not only was he so informed by the defendant's agents, but conclusive evidence of his knowledge is found in the supplementary and explanatory agreement executed at the time of the sale. In this agreement the defendant promises to use its best endeavor to obtain from the government of the United States title to the portions of the Riverside plot in which the titles are defective. The agreement was signed by the defendant's agents and was delivered to Ellis. It seems entirely plain that he had the same knowledge of the defective title as was possessed by the defendant and that, purchasing with such knowledge, he took the lands at his own risk and peril. The entire purchase amounted to 11,000 acres and it is fair to presume that the price was fixed with a view to the possible eviction of Ellis from the lands in question. To permit him to recover the purchase price when he was perfectly willing to accept the defective title would be to permit him to secure a grossly unfair advantage never contemplated at the time the sale was made.

Regarding section 51, township 9 S., of range 2 E., containing 130.50 acres, there is ambiguity in the pleadings and obscurity in the proof as to whether it was conveyed to Ellis by the defendant. Assuming, however, that the pleadings and proofs are sufficient in this regard there is no evidence of eviction. The plaintiff insists that section 51 is identical with section 61, and there is testimony to support this contention, but plaintiff's title to section 61 has not failed and she has at all times enjoyed and is to-day enjoying, so far as anything appears to the contrary, the full rights of ownership and possession. Her title is and at the time of the commencement of the suit was unassailable. This title was obtained through John Minor, who made entry in 1822, and has descended to the plaintiff through various mesne conveyances. If Ellis had paid anything to perfect this title it is certainly equitable that he should be reimbursed and the plaintiff could probably recover the amount, but the complaint is not drawn upon this theory and there is no evidence that any expense was incurred. It is this patent to John Minor that the plaintiff relies on to support her theory of eviction. The patent was issued in 1893 on the application of Ellis and for his benefit, so that the evidence relied on to prove

a defective title proves just the reverse. It shows that Ellis was by law entitled to this patent; that he procured it and his representative now holds a perfect title. It would indeed be an anomaly in the law if a vendee could evict himself from the possession of land by securing for his own benefit the only outstanding title which could ever be asserted in hostility to his own. There can be no recovery as to section 51 (or 61) for the reasons stated.

As to lot 2, section 28, in township 9 S., of range 2 E., containing 112.75 acres, the proof of eviction is insufficient. The title of the defendant was derived from a patent to Romanta Tillotson, dated November 8, 1838, and recorded May 16, 1839, in book of conveyances for Ascension parish, Louisiana. In 1893 an acting commissioner of the general land office wrote the word "Canceled" across the record of this patent. This was 55 years after the patent had issued and 5 years after the sale to Ellis. It is thought that this action was without authority and void and insufficient evidence of eviction, and that any subsequent action on the part of the officials of the land office, based on such attempted cancellation, would be equally ineffectual. As to this land, therefore, there can be no recovery.

The last tract of warranted lands is described as "adjoining lands hereinbefore described at or near New river settlement measuring $9\frac{1}{2}$ arpents front on New river more or less by 14 arpents in depth, being parallel lines bounded above by lands formerly of Ursin Hebert and Joseph Simeon Gauthreaux and below by lands formerly of Ursin Hebert designated as section 27, township 9 S., of range 2 E." The plaintiff has introduced for the purpose of showing a failure of title to this land a final homestead certificate to David Chatman for lot 3 of section 27, township No. 9 S., of range 2 E., containing 40.30 acres. Also a similar certificate to Mrs. Martha Williams for lots 5 and 6 of the same section for 80.52 acres. It is thought that these certificates are, under the law, sufficient evidence of eviction, and that the only question is whether the land referred to in the certificates is included in the land above described as conveyed under warranty by the defendant.

From the testimony and exhibits submitted it is exceedingly difficult to determine this question. The two homestead certificates relate to the N. W. $\frac{1}{4}$ of section 27, whereas the court understands that the unwarranted lands conveyed by the defendant are located in the S. E. $\frac{1}{4}$. There can be little doubt that the Williams and Chatman lots were a part of the Riverside plantation and that they were a part of the warranted land. The court is also inclined to the opinion that the allegations of the complaint have reference to this land. The proof of this is not as clear as it might be and it is difficult to understand why the plaintiff has left the question debatable when it was capable of being proved to a demonstration. The proof submitted, though unsatisfactory and incomplete, has satisfied the court that the foregoing propositions can be sustained. In other words, it is thought that were the question submitted to a jury they would be justified in finding that the Williams and Chatman homestead lands were conveyed to Ellis under warranty. The witness Brown describes this part of section 27 and locates it on the

map as a part of the Riverside plantation. If presumption be permissible the argument would be as follows: (1) The Riverside plantation was conveyed to Ellis by defendant. (2) Section 27 is a part of the Riverside plantation and was conveyed partly with and partly without warranty. (3) The land in question is not in that part of section 27 which was sold without warranty. (4) The complaint describes land in section 27 which is not in the unwarranted quarter. The conclusion derived from these premises is that the land to which the title has failed was warranted to the plaintiff by the defendant.

The court does not overlook the contention that the entire section 27, estimated by the land specifically described in the deed, was not conveyed to Ellis. It is also true that the allegation of the complaint above quoted is an inaccurate description of the lots certificated to Williams and Chatman. These lots are not within parallel lines. Certainly they are not within parallel straight lines and the acreage is different from the lands described in the complaint. The lots front on New river, however, at least for a short distance, and, taking the entire testimony into consideration, the court, while conscious that the proof might be much more satisfactory, is inclined to find that the certificates cover land warranted to Ellis. The damage for this breach of warranty is assessed at \$1,300.

It follows that the plaintiff is entitled to judgment for \$1,300 for the failure of title to the lands certificated to Williams and Chatman. As to all other causes of action and in all other respects the complaint is dismissed.

SHERIFF v. TURNER et al.

(Circuit Court, S. D. Iowa, C. D. December 19, 1902.)

No. 2,404.

1. INJUNCTION—RESTRAINING ACTION BY GOVERNMENT OFFICER.

A federal court of equity will not enjoin an army officer acting under the orders of the secretary of war, and pursuant to an act of congress providing for the building of an army post, from constructing a sewer therefrom upon lands over which the government has acquired the right of way, at suit of an owner of land lying below the projected mouth of the sewer, and through which the stream flows into which it will discharge, who alleges that the pollution of the water will interfere with the use and depreciate the value of his land. Whether the action complained of amounts to a taking of complainant's land for public use, or is a tort only, injunction is not the proper remedy.

In Equity. On application for an injunction and motion to dismiss for want of jurisdiction.

J. H. Henderson and Howard J. Clark, for complainant.
Lewis Miles, U. S. Atty.

McPHERSON, District Judge. This action is by a bill in equity praying an injunction against the defendants. The case was brought to this court on removal proceedings from the district court of Warren county. Complainant moved to remand the case, which motion

was overruled. A temporary injunction had been issued by the state court, which, on motion of defendants, was dissolved by this court. 119 Fed. 231. The complainant now asks from this court a writ of injunction against the defendants, and the defendants move to dismiss the case for want of jurisdiction.

Under an act of congress of April, 1900, the government has secured several hundred acres of land, three or four miles to the south of the city of Des Moines. North river is three or four miles to the south of said land. This stream is not meandered and is not navigable. It is a sluggish stream, with water therein all of the year, but with running water but part of the time. The government is now constructing an army post on its land, and, as an appurtenance thereto, is constructing a sewer from the post to North river. The present purpose seems to be to have the sewer terminate at North river, a short distance above complainant's dairy farm. He alleges, and no doubt correctly, that the washings from the sewer will pollute the stream, and that his cattle cannot go there for drink, and that there is no other water on his farm; and with good reason he expects that his farm will be depreciated in value from the offensive odors from the mouth of the sewer and from the pollution of the water. The defendant Turner is an officer in the United States army, with the rank of major, and as such officer, under the directions of the secretary of war, is constructing the sewer. The defendant Herrick is a contractor, and is doing said work, with the aid and under the direction of Major Turner. The defendant Turner having violated, as was said, the writ of injunction issued by the state court, and, being arrested therefor, I ordered his discharge on habeas corpus proceedings; and, an application having been made for an injunction restraining the defendant from building the sewer with the mouth thereof at a point up stream from plaintiff's land, the questions are: Has this court jurisdiction in the case? and, if so, should the writ issue?

A federal question is involved, and the case was properly removed to this court. By continuing the sewer for comparatively a short distance it would terminate at the Des Moines river, or so near thereto as to be harmless to all; and that that is what should be done, and must be done, I have no doubt. It has been the recognized rule in Iowa for a third of a century that the higher owner shall not collect surface waters and turn them on the land below. *Livingston v. McDonald*, 21 Iowa, 160, 89 Am. Dec. 563. That case has been uniformly followed to the present time. And the greater is the reason for not allowing the collection of filth and dumping that on the land of another, thereby creating a nuisance, which probably could be abated, both by indictment and in equity, under the Iowa practice acts. That the government will not do this, when the matter is brought to the attention of the proper officer, I have no doubt. But, if it does, then either the complainant must suffer a great wrong or be accorded some remedy.

But these statements are not decisive of the questions now before me. Under the authority of the case of *U. S. v. Lee*, 106 U. S. 196, 27 L. Ed. 171, and cases therein cited, as well as by many subse-

quent cases, an owner can maintain an action for, and recover possession of, property that belongs to him, as against an officer, military or civil, of the government, who claims possession thereof for and on behalf of the government; and such claim is no defense, for the stated, and as it seems to me the obvious, reason that the government in such a case cannot be made a defendant, because the government in no case can be sued without its consent, and such consent can only be given by congress. In a limited class of cases, such consent has been given by statute. And it is equally so that an officer, military or civil, who unlawfully takes or trespasses upon property is personally liable for damages. *Mitchell v. Harmony*, 13 How. 115, 14 L. Ed. 75, and the annotations to that case as found in Rose's notes.

But neither of the above holdings is authority for issuing the writ of injunction against the construction of public works under an act of congress, by direction of the secretary of war, and theoretically by direction of the president. The fact will be kept in mind in this case that Major Turner has not taken, and he does not threaten to take, any of complainant's property. He is not in possession of, and does not threaten to take possession of, any of complainant's property. The acts complained of are these: As a military officer, under an act of congress, by direction of the secretary of war, he is building an army post. That is fully authorized, and therefore not an unlawful act. Under the same authority, and as an appurtenant to the post, he is constructing a sewer, which is desirable, and probably necessary, both for the health and safety of the soldiers to be stationed there, as well as the health and safety of people residing near by, as well as for the people of the city of Des Moines. That he is properly, and according to modern methods, constructing the sewer, is not questioned. That the sewer is wholly upon grounds acquired for that purpose is conceded. But, owing to the location of the mouth of the sewer, the washings from the sewer will be carried on and over complainant's lands, and the offensive odors will be carried on and across his premises; and, by reason of both, complainant believes that he will suffer damages; and, as above stated, he has reason to so believe, provided the mouth of the sewer is to be and remain at North river.

Under the patent laws, it has been held several times that the government, without license or consent, has no right to use the patented article; and an officer of the government, using the article for and on behalf of the government, cannot justify such use. *James v. Campbell*, 104 U. S. 356, 26 L. Ed. 786; *U. S. v. Palmer*, 128 U. S. 262, 271, 9 Sup. Ct. 104, 32 L. Ed. 442; *Solomons v. U. S.*, 137 U. S. 225-343, 11 Sup. Ct. 88, 34 L. Ed. 667; *U. S. v. Burne*, 12 Wall. 247, 20 L. Ed. 388. The *Palmer*, *Solomons*, and *Burne* Cases were brought directly in the court of claims against the United States, under statutes allowing the government to be sued on contract, express or implied. And as the using of patented articles is a taking of property, and when so taken by the government is taken with an implied promise to pay therefor, such cases were properly brought in the court of claims. And in the case at bar the threatened inva-

sion of complainant's rights is contended by complainant as being a taking of his property for public use. If so, he has his remedy at law by suit against the government on the implied promise to pay him.

The case of *James v. Campbell*, above cited, was an equity case brought in the circuit court by Campbell, the patentee, against James, the postmaster of New York City, for using a letter stamping device. The circuit court gave a decree for complainant, which was reversed by the supreme court, because of the lack of merit in the case. But the court, by Justice Bradley, said :

"The course adopted in the present case, of instituting an action against a public officer, who acts for and in behalf of the government, is open to serious objections. We doubt very much whether such an action can be sustained. It is substantially a suit against the United States itself, which cannot be maintained under the guise of a suit against its officers and agents, except in the manner provided by law. We have heretofore expressed our views on this subject in *Carr v. U. S.*, 98 U. S. 433, 25 L. Ed. 209, where a judgment in ejectment against a government agent was held to be no estoppel against the government itself."

That case was not decided on the point above quoted, and the case was decided after the decision in *U. S. v. Lee*, supra. But the decision in *U. S. v. Lee* rested upon a number of long-time prior decisions, and the reasons given and stated by so eminent a judge as was Justice Bradley have much weight with me. And the reasons are the stronger from the fact that in another part of the opinion the court said it was an open question whether the damages could be recovered in an action in the court of claims, or whether the party must rely upon the fairness of congress. So far as I am advised, this question has not again been before the supreme court in a patent or like case.

And again, if in the case at bar it is a taking of private property for public use, then the answer is that the federal constitution does not require payment in advance, as do many of the state constitutions, and particularly where the government itself is taking the property for its own use. But to my mind it is more than doubtful if the government is taking complainant's property. Physically, beyond dispute, it is not taking his property. All that can be said is that, if the mouth of the sewer is placed as suspected it will be, complainant's property will be depreciated in value. It often happens that private interests must yield for the public good, as was held in *Mugler v. Kansas*, 123 U. S. 623, 8 Sup. Ct. 273, 31 L. Ed. 205, where the state rendered Mugler's property worthless in the exercise of the police power.

Probably the sewer in question, constructed in any manner, terminating at any point, will be harmful in some degree to some one or more persons. At least a moral obligation rests upon the officers: to so construct it as to do as little harm as possible, and to be the most serviceable to the post; and in so determining and in so constructing a high degree of engineering skill and judgment and good sense are called for. But in no case will an officer be enjoined from doing an act other than mere ministerial acts. But, if the act calls for judgment and discretion, the injunction will not issue. Kir-

wan v. Murphy, 83 Fed. 275-280, 28 C. C. A. 348; Noble v. Railroad Co., 147 U. S. 165, 13 Sup. Ct. 271, 37 L. Ed. 123.

It therefore seems to me that complainant has an adequate remedy at law. Particularly is this so, if it is a taking of property as his counsel contend, although I do not hold that he can avail himself of the statute for condemning private property for public use. But if the acts amount only to a tort, for which the government cannot be sued, and his only remedy is to ask for compensation from congress, for the reasons above given, an injunction should not issue. But whether this court has jurisdiction in any other phase of the case is a question that has not been elaborately argued.

For the present the case will be retained. In the meantime any ruling can be reviewed; and probably in the meantime the war department will adjust all matters to the satisfaction of all. So that the application for an injunction will be denied, and the motion to dismiss the case will be overruled, with the right of each party to again make their respective applications without the orders now made being a bar.

UNITED STATES v. LEW POY DEW.

(District Court, N. D. New York. January 24, 1903.)

1. JUDGMENT—CHINESE ALIEN—RIGHT TO REMAIN IN UNITED STATES—PROOF OF ADJUDICATION.

In a proceeding for the deportation of a Chinese person, a certificate, signed by a United States commissioner, that complaint was presented before him charging that the defendant was unlawfully within the United States, and that the defendant was brought before him, and that upon full hearing it was adjudged by him that the defendant had a lawful right to be and remain in the United States, and he was accordingly discharged, is inadmissible in proof of a prior adjudication of defendant's right to remain in this country; it not being a certified copy of such adjudication, but a mere recital that such judgment had been rendered.

Appeal from Judgment of United States Commissioner.

The defendant appeals from a judgment of deportation made by Benjamin L. Wells, as United States commissioner for the Northern district of New York, on the 31st day of October, 1902. This judgment, after fully reciting the proceedings, adjudges as follows: "I now hereby find and adjudge that the said Lew Poy Dew is a Chinese person and a laborer, is not a citizen of the United States, that he is not a diplomatic or other officer of the Chinese or any other government, and that he unlawfully entered the United States, as charged in said complaint. And I further adjudge him, said Lew Poy Dew, guilty of not being lawfully entitled to be or remain in the United States. I further find and adjudge that he, said Lew Poy Dew, came from the dominion of Canada; but he has not made it appear to me that he was a subject or a citizen of some other country than China. I further find and adjudge that he, said Lew Poy Dew, entered the United States on or about the 23d day of July, 1902, without having a certificate, required by law, entitling him to enter the United States. Then follows the clause ordering deportation, etc. The appeal rests upon alleged error in rejecting a certificate

¶ 1. Citizenship of Chinese, see notes to *Gee Fook Sing v. U. S.*, 1 C. C. A. 212, and *Lee Sing Far v. U. S.*, 35 C. C. A. 332.

presented by the defendant on the trial and offered in evidence. The certificate is in the words and figures following:

"United States of America, District of Vermont.

"Before me, Felix W. McGettrick, a commissioner of the circuit court of the United States within and for said district, complaint was presented by John H. Senter, United States attorney within and for said district, charging in substance that on or about the 1st day of June, 1897, at Richford, Vt., in said district, Lew Poy Dew, in violation of section — of the Revised Statutes of the United States, did unlawfully come and was in the United States, and on the 1st day of June, 1897, defendant was brought before me, the said commissioner, at my office in St. Albans, in said district, and upon full hearing on said charge, the said district attorney being present, it was adjudged by me that said Lew Poy Dew had the lawful right to be and remain in the United States, and he was accordingly discharged.

"Given under my hand and seal at St. Albans, in the district of Vermont, this 1st day of June, 1897.

Felix W. McGettrick,

"United States Commissioner for the District of Vermont."

The defendant offered no other evidence as to his right to be or remain in the United States. On the hearing before the commissioner the defendant by his counsel admitted "that the defendant is a Chinese person, not a member of the exempt class, that he came into the United States from the dominion of Canada, and was apprehended as charged in the complaints and warrants in these cases." The complaint and warrant charges "that on or about the 23d day of July, A. D. 1902, at Burke, N. Y., in said district [Northern district of New York], Lew Poy Dew, a Chinese person and laborer, in violation of the Chinese exclusion laws and of the Revised Statutes of the United States, did unlawfully enter, and was then and there found not lawfully in, the United States of America, contrary to the form of the statute of the United States of America in such case made and provided."

Geo. B. Curtiss, U. S. Dist. Atty.

R. M. Moore, for defendant.

RAY, District Judge (after stating the facts as above). The question presented on this appeal is whether the certificate above recited was admissible in evidence for any purpose. The defendant relied upon it as evidence or proof that it has been duly adjudicated by a competent tribunal or officer that on the 1st day of June, 1897, the defendant, Lew Poy Dew, did not unlawfully come into, and was not then unlawfully within, the United States, and that he had the lawful right to be and remain in the United States. This certificate is not, and does not purport to be, the judgment or decision of the United States commissioner, Felix W. McGettrick, or a copy thereof. It is a mere recital of certain alleged official acts or transactions of McGettrick as United States commissioner, and of certain proceedings alleged to have been had before him. It is a mere recital of past transactions, and is equivalent to a written statement, made and signed by the judge of a court, that he had at a certain time adjudged and determined that certain facts did or did not exist, and had given judgment accordingly. This certificate does not purport to be a copy or a transcript of any decision made, or of any judgment rendered, in any legal proceeding. It is not a certificate authorized by any law, and therefore not an official act of said commissioner. It is not a return or statement made to any official or department of the government, but merely a roving general certificate, and is no more evidence in a court of justice to establish the facts recited than would be a letter from

the clerk of a court to the complainant in an action that he had entered a judgment, reciting its terms, in his favor on a certain day.

The judgment or determination of a court, or of an officer thereof authorized to render one, may be proved in two ways: By the original records duly identified, and, if from another court, duly proved; or by a duly certified and authenticated copy. *Society v. Spiro*, 37 C. C. A. 388, 94 Fed. 750. *O'Hara v. Railroad Co.*, 22 C. C. A. 512, 76 Fed. 718. Such is the rule in the various states. *Handly v. Greene*, 15 Barb. 602; *Baker v. Kingsland*, 10 Paige, 366; *Lansing v. Russel*, 3 Barb. Ch. 325. These cases state the rule as held and applied in the courts of the United States.

In *Society v. Spiro*, supra, the court says that section 905, Rev. St. [U. S. Comp. St. 1901, p. 677], has no application to the proof of judgments of the United States courts rendered in one jurisdiction in those of another. But in *O'Hara v. Railroad Co.*, supra, it is stated that it is the uniform practice to follow the requirements of that section in authenticating the records of the United States courts.

In *Turnbull v. Payson*, 95 U. S. 418, 24 L. Ed. 437, it is held:

"The record of a district court of the United States is not within the act of congress approved May 26, 1790 (1 Stat. 122), prescribing the mode in which the records and judicial proceedings of the state courts shall be authenticated, but is, when duly certified by the clerk under its seal, admissible as evidence in every other court of the United States."

Says the court:

"Circuit and district courts of the United States certainly cannot be considered as foreign in any sense of the term, either in respect to the state courts in which they sit, or as respects the circuit or district court of another circuit or district. On the contrary, they are domestic tribunals, whose proceedings all other courts of the country are bound to respect, when authenticated by the certificate of the clerk under the seal of the court; the rule being that the circuit court of one circuit, or the district court of one district, is presumed to know the seal of the circuit court or district court of another circuit or district, in the same manner as each court within a state is presumed to know and recognize the seal of any other court within the same state."

Says Wharton (2 Law Ev. 3d Ed.):

"At the same time it must be remembered that records of a federal court, certified to by the clerk of the court under the seal of the court, without the certificate of the chief judge, may be received by other federal courts."

While a United States commissioner has no clerk, and it may be that where a certified copy of his records is admissible, if there be such a case, his own certificate is sufficient, the difficulty with the certificate offered in evidence is not obviated on such theory. The commissioner did not make a copy of his records or judgment, and certify that, but certifies in a general way that he did certain things and made certain adjudications. This is not the best evidence, or even the best secondary evidence; and, within the rule that requires the best evidence when obtainable, the certificate was properly rejected. No authority is found that would justify the admission in evidence of this certificate.

2 Freem. Judgm. (4th Ed.) § 407, p. 715, and cases there cited:

"But if the party offering a record does so in support of a plea of *res judicata*, or to show that he has acquired or his adversary has lost some title or right either by the judgment alone or by it and proceedings taken for

its enforcement, "the whole record, so far as it concerns the formal stages, must be either produced or exemplified, and, if exemplified, the exemplification must show on its face that the record is complete and is regular, nor can the record be patched with parol." A certificate of the result of the record, by whomsoever made, is not admissible. Hence a certificate, though under the hand of the clerk of a court and attested by its seal, that a divorce was decreed by the court, 'as will more fully appear by the record of the proceedings in this office,' is not admissible, because 'an official certificate of what is contained in a record, docket, deed, or other instrument is not admissible in evidence, unless made so by statute.' Nor can a paper be admitted which is certified to be an extract from the record."

In *Oakes v. Hill*, 31 Mass. 442, it was held:

"The recording officer of religious and other corporations may make copies of his records, and his certificate will be evidence of the verity of the copy; but it is no part of his duty to certify facts. Wherefore, where the clerk of a religious society certified simply 'that the plaintiff, at his own request, had ceased to be a member of the society,' it was held that the certificate was not legal evidence of that fact."

While this is not the case of a judgment, it illustrates one principle contended for, that the certificate of an officer is worthless as evidence unless the making of it was an official duty, and even then it is not evidence except so far as made such by some statute. No more loose, dangerous, and unsatisfactory mode of proving the judgment of a court could be devised than to permit the introduction in evidence, against objection, of the mere unsworn statement of a commissioner that he has made a certain adjudication, when there is no statute making it his duty to make such a certificate. It is not the best evidence, nor is it sworn evidence, nor is it made evidence by any statute. "A consular certificate is not evidence of any act, except as provided by statute." *The Alice* (D. C.) 12 Fed. 923; *Levy v. Burley*, 2 Sumn. 355, Fed. Cas. No. 8,300; *Church v. Hubbard*, 2 Cranch, 187, 2 L. Ed. 249; *U. S. v. Mitchell*, 2 Wash. C. C. 478, Fed. Cas. No. 15,791. There is far less reason for admitting in evidence the mere certificate of a United States commissioner as to the terms and effect of some adjudication made by him.

Evidence was given that this man McGettrick was engaged in the business of making and selling such certificates. While this fact alone would not invalidate this certificate, were it made evidence by some statute, it shows the wisdom of the rule which requires judgments to be proved by the originals or by proved copies, as stated in the *Spiro Case*. The doctrine is old that the best and highest evidence in the power of a party must be produced. No case cited by the learned counsel for the defendant conflicts with this rule. In *Ballew v. U. S.*, 160 U. S. 187, 16 Sup. Ct. 263, 40 L. Ed. 388, a duly certified copy was produced, and it was held that section 882, Rev. St. [U. S. Comp. St. 1901, p. 669] was substantially complied with. In *Railroad Co. v. Burton*, 111 U. S. 788, 4 Sup. Ct. 699, 28 L. Ed. 604, there was a transcript of the decree of naturalization. In *U. S. v. Bell*, 111 U. S. 477, 4 Sup. Ct. 498, 28 L. Ed. 477, there was a certified transcript from the books of the treasury department. In *Moses v. U. S.*, 166 U. S. 571, 17 Sup. Ct. 682, 41 L. Ed. 1119, there were transcripts from the books of the treasury department, and these were held sufficient within section 886, Rev. St. [U. S. Comp. St. 1901, p. 670]. In

Stearns v. Lawrence, 28 C. C. A. 66, 83 Fed. 738, it was held that under the provisions of the constitution of the state of Michigan, which require that the decisions of the supreme court be in writing and signed by the judges and filed in the clerk's office, the opinion of that court so filed in a case is competent evidence of the questions adjudicated therein in a subsequent action wherein that decision was sought to be used as an estoppel. None of these cases afford the slightest support to the contention of the defendant here.

The commissioner was neither required nor authorized to make this certificate, and it is doubtful if he could be punished, should it appear that it is false in all its statements. Clearly it is not evidence or admissible for any purpose. It is unnecessary to consider its effect if admissible. The certificate does not state upon what ground or for what reasons the commissioner then determined that the defendant was entitled to be and remain in the United States. He had left the United States, and came back in 1892, and entered illegally. We find a photograph of the defendant attached to this certificate, but there is no evidence to show when it was attached. There is no pretense that this certificate is evidence of the right of the defendant to be or remain in this country, except on the theory of *res judicata*, which claim, as we have seen, is untenable.

It follows that no error was committed in rejecting the certificate, and, as the defendant offered no other evidence, the judgment of deportation must be affirmed. It is so ordered.

UNION TRUST CO. v. STEARNS et al.
(Circuit Court, D. Rhode Island. January 6, 1903.)

No. 2,615.

1. JURISDICTION OF FEDERAL COURTS—SUIT AGAINST STATE—ENJOINING CRIMINAL PROSECUTIONS UNDER STATE STATUTE.

A suit against the attorney general and assistant attorney general of a state to enjoin them from instituting criminal prosecutions in the name of the state under a state statute, by which they are charged with no special duty, and to which they bear no different relation than to any other penal statute, is a suit against the state, within the meaning of the eleventh constitutional amendment, of which a federal court is without jurisdiction.

In Equity. On demurrer to bill.

Edwards & Angell and Walter F. Angell, for complainant.
Charles F. Stearns, for defendants Stearns and Greenough.
Wm. J. Brown, for defendant Rhode Island Suburban Ry. Co.

COLT, Circuit Judge. The eleventh amendment to the constitution of the United States was adopted in 1798 as a result of the decision of the supreme court in *Chisholm v. Georgia*, 2 Dall. 419, 1 L. Ed. 440. This amendment declares that the judicial power of the

¶ 1. Federal jurisdiction of suits against state, see note to *Tindall v. Wesley*, 13 C. C. A. 165.

United States shall not be construed to extend to any suit in law or equity commenced or prosecuted against one of the United States by citizens of another state, or by citizens or subjects of any foreign state. If this is a suit against the state of Rhode Island, the court is without jurisdiction, and the bill must be dismissed. This is the question raised on the demurrer to the bill by the defendants Stearns and Greenough. The purpose of the eleventh amendment was to prevent the subjection of a state to the coercive process of judicial tribunals at the instance of private parties. To secure this purpose the amendment has been interpreted "not literally, and too narrowly, but fairly, and with such breadth and largeness as effectually to accomplish the substance of its purpose." Accordingly, it has been held that the state need not be formally named as a party. It is sufficient if it is the real party against whom the suit is brought. It has also been adjudged that this prohibition extends to suits against a state by citizens of the same state. *Ex parte Ayers*, 123 U. S. 443, 505, 506, 8 Sup. Ct. 164, 31 L. Ed. 216; *Hans v. Louisiana*, 134 U. S. 1, 10 Sup. Ct. 504, 33 L. Ed. 842; *Fitts v. McGhee*, 172 U. S. 516, 524, 528, 529, 19 Sup. Ct. 269, 43 L. Ed. 535. The general assembly of the state of Rhode Island, on June 1, 1902, passed an act to regulate the hours of labor of certain employes of street railways. The act contains the following section relating to fines for violating any of its provisions:

"Sec. 3. Any street railway corporation violating any of the provisions of the preceding sections of this act shall be fined not less than one hundred dollars nor more than five hundred dollars, one-half thereof to the use of the complainant and the other half to the use of the state." Pub. Laws 1902, c. 1004.

The bill avers that the fines imposed by this act must be recovered by indictment preferred and prosecuted by the attorney general or the assistant attorney general of the state; that the defendants Stearns and Greenough are, respectively, the attorney general and assistant attorney general; and that they threaten and intend to prefer and prosecute indictments under the act, and to collect the fines imposed; and the bill prays that Stearns and Greenough may be restrained and enjoined from enforcing the act by means of indictment or otherwise. The defendants Stearns and Greenough are not named in the act, nor charged with any special duty in connection therewith. They do not occupy any different relation with respect to this penal statute than with respect to other penal statutes of the state. It is their duty, by virtue of the offices they hold, to institute proceedings for the enforcement of this statute, just as it is their duty to institute proceedings for the enforcement of other penal laws. They are threatening to do no wrong or trespass against this complainant in any other sense than is involved in the threatened prosecution of all violators of the criminal laws of Rhode Island. If they can be restrained from instituting prosecutions under this act, they equally may be restrained from instituting prosecutions under any criminal law of the state. In this way the enforcement of every criminal statute of the state might be enjoined by a bill in equity brought in the federal courts against these defendants, until the

question of constitutionality has been finally passed upon by the supreme court of the United States.

The purpose of the present bill, in substance and effect, is to enjoin the state of Rhode Island from the enforcement of a penal statute. Indictments under the act are brought in the name and on behalf of the state for the protection of the state. These defendants, the attorney general and his assistant, merely represent the state in such proceedings. They are simply the officers and agents of the state. It is not as individuals, but solely by virtue of their holding such offices, that they prefer and prosecute indictments in the name of the state. A state can only act or be proceeded against through its officers. If a decree could be entered against the state of Rhode Island enjoining prosecutions under this act, it could only operate against the state through enjoining these defendants. An order restraining the attorney general and his assistant from the enforcement of this statute is an order restraining the state itself. The present suit, therefore, is as much against the state of Rhode Island as if the state itself were named a party defendant. *Ex parte Ayers*, 123 U. S. 497, 8 Sup. Ct. 164, 31 L. Ed. 216; *Fitts v. McGhee*, 172 U. S. 529, 19 Sup. Ct. 269, 43 L. Ed. 535.

The supreme court has decided in several cases that a suit to enjoin the attorney general of a state from bringing suits or prosecuting indictments under a state statute is a suit against the state.

In the case of *Ex parte Ayers* it was held that a suit against the attorney general of Virginia and certain other state officers to enjoin them from proceeding to enforce an alleged unconstitutional statute of the state was a suit against the state. The prayer of the bill in that case was that R. A. Ayers, attorney general of Virginia, the auditor of the state, and the treasurer and attorney of each county, city, and town "may be restrained and enjoined from bringing or commencing any suit provided for by the said act of May 12, 1887, or from doing any other act to put said statute into force and effect." The circuit court ordered the injunction prayed for. The supreme court reversed this order, and directed the bill to be dismissed on the ground that the suit was against the state of Virginia, within the meaning of the eleventh amendment to the constitution of the United States. 123 U. S. 443, 450, 507, 8 Sup. Ct. 164, 31 L. Ed. 216.

In *Fitts v. McGhee* it was held that a suit brought to restrain the attorney general of the state of Alabama and one of the state's solicitors from taking steps to enforce a legislative act claimed to be unconstitutional was a suit against the state. The act was for reducing tolls on a bridge which crossed the Tennessee river. The circuit court adjudged the statute unconstitutional and void, and enjoined the defendants from instituting or prosecuting any proceedings under the forfeiture clause of the act, or by mandamus or otherwise to compel the observance of and obedience to the act. In reversing the judgment of the circuit court and dismissing the bill, the supreme court said:

"As a state can act only by its officers, an order restraining those officers from taking any steps, by means of judicial proceedings, in execution of the

statute of February 9, 1895, is one which restrains the state itself, and the suit is consequently as much against the state as if the state were named as a party defendant on the record." 172 U. S. 516, 529, 19 Sup. Ct. 269, 43 L. Ed. 535.

In *Cotting v. Stock Yards Co.*, 183 U. S. 79, 22 Sup. Ct. 30, 46 L. Ed. 92, the supreme court dismissed the bill as to the attorney general upon his objection that the suit was against the state. That was a bill brought by a nonresident stockholder against the defendant company and the attorney general of the state of Kansas, for the purpose of declaring unconstitutional and void a statute of the state regulating the charges of stock yards, and for enjoining the attorney general from instituting proceedings to enforce the statute. The attorney general appeared, but did not raise the objection that the suit was against the state until after a full hearing and a decision on the merits, and just previous to the entry of a final decree in the circuit court. Under these circumstances the supreme court considered the case on its merits, dismissed the bill as to the attorney general, and expressed no opinion on the question of jurisdiction. The court said:

"Without expressing any opinion as to the jurisdiction of the court if it had been properly and seasonably challenged, we think the true solution of this matter will be found in reversing the decree upon the merits, and directing a dismissal of the suit as to the attorney general, without prejudice to any other suit or action." 183 U. S. 114, 22 Sup. Ct. 30, 46 L. Ed. 92.

These decisions have never been questioned, and they are controlling and binding on this court in the case at bar.

There is a class of cases in which the supreme court has held that a suit against state officers was not a suit against the state. The principle governing these cases is not applicable to the present suit. Briefly stated, that principle is that such officers, as individuals, have committed, or are about to commit, a wrong or trespass, for which they are personally liable in a suit at law or in equity. This doctrine was first enunciated by Chief Justice Marshall in *Osborn v. Bank*, 9 Wheat. 738, 871, 6 L. Ed. 204. In that case there was an unlawful seizure and detention of property by state officers in pursuance of an unconstitutional statute of Ohio, and in violation of the act of congress chartering the bank; and an action at law, either in trespass or detinue, could have been brought against them as individual trespassers guilty of wrong in taking the property of the complainant illegally. Under such circumstances they were not permitted to protect themselves against personal liability as representatives of the state, because the authority under which they professed to act was void. *Ex parte Ayers*, 123 U. S. 499, 500, 8 Sup. Ct. 164, 31 L. Ed. 216. In *Allen v. Railroad Co.*, 114 U. S. 311, 5 Sup. Ct. 925, 962, 29 L. Ed. 200, the same principle was enforced against state officers to restrain the collection of taxes by seizure of property under an unconstitutional legislative act. In *Poindexter v. Greenhow*, 114 U. S. 270, 5 Sup. Ct. 903, 962, 29 L. Ed. 185, the same doctrine is stated and applied. *U. S. v. Lee*, 106 U. S. 196, 27 L. Ed. 171, is another illustration of the same principle. In that case the plaintiffs had been wrongfully dispossessed of their real estate by the defendants, claiming to act under the authority of the United States.

As they were unable to show any such lawful authority, it was held that there was nothing to prevent the judgment of the court against them as individuals for their individual wrong and trespass. In reviewing this class of cases in *Ex parte Ayers*, Mr. Justice Matthews, speaking for the court, said:

"The vital principle in all such cases is that the defendants, though professing to act as officers of the state, are threatening a violation of the personal or property rights of the complainant, for which they are personally and individually liable. * * * This feature will be found, on an examination, to characterize every case where persons have been made defendants for acts done or threatened by them as officers of the government, either of a state or of the United States, where the objection has been interposed that the state was the real defendant, and has been overruled. The action has been sustained only in those instances where the act complained of, considered apart from the official authority alleged as its justification, and as the personal act of the individual defendant, constituted a violation of right for which the plaintiff was entitled to a remedy at law or in equity against the wrongdoer in his individual character." 123 U. S. 500, 501, 502, 8 Sup. Ct. 164, 31 L. Ed. 216.

The same doctrine has been applied to another class of cases in which suit has been brought against state officers. These are cases where the state officers compose a board or commission endowed by legislative enactment with administrative powers which cannot be enforced without violating constitutional rights. It is held that these suits are not against the state in any proper sense, but against the individuals composing the board or commission, who, as individuals, though claiming to act as officers, are threatening a violation of personal or property rights under the color of an unconstitutional statute. *Pennoyer v. McConaughy*, 140 U. S. 1, 11 Sup. Ct. 699, 35 L. Ed. 363; *Reagan v. Trust Co.*, 154 U. S. 362, 14 Sup. Ct. 1047, 38 L. Ed. 1014; *Smyth v. Ames*, 169 U. S. 466, 18 Sup. Ct. 418, 42 L. Ed. 819. It is upon the last-cited case of *Smyth v. Ames* that the complainant largely relies to support the jurisdiction of the court in the present case, and especially upon the following language from the opinion of the court in that case:

"It is the settled doctrine of this court that a suit against individuals for the purpose of preventing them, as officers of a state, from enforcing an unconstitutional enactment to the injury of the rights of the plaintiff, is not a suit against the state within the meaning of that [the eleventh] amendment." 169 U. S. 518, 18 Sup. Ct. 418, 42 L. Ed. 819.

Smyth v. Ames was a bill in equity brought against the state board of transportation of Nebraska and other parties. By a legislative act this board was composed of certain state officers, including the attorney general, and was empowered to regulate and reduce railway fares. The main purpose of the bill was to declare the act unconstitutional and void, and to restrain the board from proceeding to enforce the act. The only persons who prosecuted the appeal in the supreme court were the defendants who constituted the board and the secretaries of the board. No question was raised or determined in that case, or could have been raised or determined upon the record, as to whether a suit against the attorney general of Nebraska was a suit against the state. As the case stood in the supreme court, it was directed solely against the board and against the at-

torney general as one of the individuals composing the board. The jurisdiction of the court to entertain a suit against the board was apparently so plain that the question was not argued by counsel. The language of Mr. Justice Harlan in the opinion of the court cannot be extended beyond the case that was before the court. It was a mere statement by him of the doctrine which had frequently been enforced by the supreme court in this class of cases. This is shown by the citation of authorities at the end of the paragraph above quoted. There is certainly no ground for saying that *Smyth v. Ames* overrules the earlier case of *Ex parte Ayers*, or that it is in conflict with the later case of *Fitts v. McGhee*, in both of which cases it was expressly decided that suits against the attorney general were suits against the state.

The distinction between the two lines of cases is clearly stated in *Fitts v. McGhee*. After referring to *Smyth v. Ames* and other similar cases, Mr. Justice Harlan, in giving the opinion of the court, said:

"There is a wide difference between a suit against individuals, holding official positions under a state, to prevent them, under the sanction of an unconstitutional statute, from committing by some positive act a wrong or trespass, and a suit against officers of a state merely to test the constitutionality of a state statute, in the enforcement of which those officers will act only by formal judicial proceedings in the courts of the state." 172 U. S. 529, 530, 19 Sup. Ct. 269, 43 L. Ed. 535.

The defendants Stearns and Greenough hold no special relation to the act of June 1, 1902. They are not specially charged with its execution. They are not thereby constituted a board or commission with administrative powers, nor are they as individuals, and apart from the official authority under which they act, threatening to seize the property of the complainant, or to commit any wrong or trespass against its personal or property rights. They have no other connection with this statute than the institution of formal judicial proceedings for its enforcement in the courts of the state in the name and behalf of the state. Upon reason and authority the present bill is a suit against the state of Rhode Island, within the meaning of the eleventh amendment to the constitution of the United States.

The bill further prays that the defendant the Rhode Island Suburban Railway Company may be enjoined from permitting its employes from working more than 10 hours per day, in violation of the provisions of the act of June 1, 1902. The Suburban Company has demurred to the bill on the ground that the act, under a proper construction thereof, does not prohibit a street railway company from making voluntary agreements with its employes to work more than 10 hours per day. The bill, in this aspect, presents only the question of the proper construction of a state statute. Since this is not a federal question, and since the requisite diversity of citizenship is also absent, the complainant and this defendant being citizens of the same state, the court is without jurisdiction to retain the bill as between these parties.

The demurrer of the defendants Stearns and Greenough is sustained, and the bill dismissed.

In re BALDWIN.

(District Court, N. D. New York. January 16, 1903.)

1. BANKRUPTCY—SPECIFICATIONS IN OPPOSITION TO DISCHARGE—OBJECTIONS TO SUFFICIENCY.

It is the settled practice in the Northern district of New York to require all objections to the sufficiency of specifications of objection to the discharge of a bankrupt to be raised before the judge, on motion, within a specified time.

2. SAME—TRIAL OF ISSUES ON APPLICATION FOR DISCHARGE—OBJECTIONS TO EVIDENCE.

Objection that evidence offered on the trial of specifications of objection to a bankrupt's discharge is not within the issues must be made before or during the trial before the referee, or it is waived.

In Bankruptcy. On motion to confirm the report of the referee and grant a discharge.

David H. Agnew, for the motion.

S. L. Wheeler, opposed.

RAY, District Judge. Charles R. Baldwin filed his petition in bankruptcy on the 12th day of August, 1901. He was duly adjudicated a bankrupt, and filed his schedules, in which he omitted any mention of or reference to certain property hereafter mentioned, and which the creditor opposing the discharge now asserts was knowingly and fraudulently concealed by the bankrupt, shortly before the filing of his petition, for the purpose of keeping it as his own, and was also knowingly and fraudulently concealed during the pendency of the proceedings from the trustee, and that it was colorably transferred, with the secret and fraudulent understanding that, when discharged, it should be returned to him. It is also claimed that in fact such property at all times during the pendency of such proceedings, and down to about the time of the hearing on his application for a discharge, was so far in his actual possession as to be within his control and subject to his order, and was in fact owned by him, and knowingly and fraudulently concealed from the trustee. The bankrupt claims that such property was in fact, and more than four months prior to the filing of such petition, turned over and transferred to one Abbie M. Gay, his sister-in-law and housekeeper, in good faith, and in payment of a just claim she had against him for services, and that all of his subsequent dealings with such property or its proceeds were either as agent for the owner, or friendly acts such as he naturally would or ought to perform for his sister-in-law. If the contention of the opposing creditor is correct, and established by satisfactory evidence, the petitioner is not entitled to his discharge. The objections and specifications of the opposing creditor are quite informal and somewhat defective. But no demurrer, or motion in the nature of a demurrer, was interposed, and the parties proceeded to a hearing and went through the trial without raising the question of their sufficiency. It was then too late to raise that question. The bankrupt, by pursuing this course, waived all objections to their sufficiency. The specifications of objection plainly indicated the mat-

ters to be questioned, and there can be no pretense that the petitioner was misled or prejudiced.

It is now the settled practice of this court to require all objections to the sufficiency of the specifications to be raised before the judge on motion, within a specified time, and all orders of reference as to discharge contain such a provision. Objections must be made prior to the trial or during the trial that the evidence is not within the issue framed. Where an issue has been tried without objection, it is too late to object that it was not within the pleadings.

In September, 1900, this petitioner, Charles R. Baldwin, moved from Ausable Forks, N. Y., to Syracuse. He then owned property of the value of at least \$2,750, including real estate valued at \$700. He was owing \$975, exclusive of the alleged claim of Mrs. Gay, his sister-in-law. While in Syracuse he worked for or in a company of some kind, and received from \$50 to \$100 per week. In Syracuse he sustained some losses,—how or how much does not appear. At Christmas time he returned to Ausable Forks. August 12th following, he filed his petition in bankruptcy. About March 1, 1885, said Abbie M. Gay, an alleged creditor of the bankrupt, commenced living with him and keeping his house; his wife having died. She was to take charge of his family,—his household,—and, it is claimed, do his work, for pay. Mrs. Gay says she was to have \$3 per week, and that this bargain was made at his house shortly after the death of Mrs. Baldwin. She concedes that nothing was paid her,—nor does it appear that she demanded anything,—until November, 1900, when Baldwin got into financial trouble in Syracuse. The bankrupt himself testified that no price for the services of Mrs. Gay was fixed until near December, 1900, after he knew he was insolvent. On a prior occasion, Baldwin testified there was no agreement Mrs. Gay should have pay for her services when she came to his home to live. As an original proposition, this court would hold that the evidence falls short of establishing a claim in her favor. The stories told by Mrs. Gay and Baldwin are inherently improbable, and they contradict themselves and each other. It is not credible that this woman worked nearly 15 years at the agreed price of \$3 per week, and received nothing during the time. But it appears that the claim was presented, proved, and allowed by the referee. It is of doubtful propriety for this court now, on the application for a discharge, to find and hold that this was a bogus claim. Mrs. Gay says that in November, 1900, she had a settlement with Baldwin, and received \$267, also a deed of his land at \$700, and a note for \$211 (cannot tell whose note), and a further sum of \$200 in cash; "some of that quite recently, and some some time ago"; some of it within two weeks of her examination, which took place on March 20, 1902, on a hearing for the discharge of Baldwin. Of this she received \$100 from one Fred Hinds, who paid it for Baldwin on his order to pay that sum to her. She also says the \$267 was not paid in cash, but by turning over to her a note given by one Flint. She then states that March 1, 1889 or 1890, Baldwin gave her his note for \$500, for money she had loaned him. When the note was produced and put in evidence, it bore date May 1, 1899,—10 years later. She

gave other interesting testimony, not necessary to mention. Mr. Hinds says he did not pay any money directly to Mrs. Gay; that he received from Baldwin, the bankrupt, notes given by Dr. Baldwin; that Baldwin, the bankrupt, left them with him for collection; that he collected the notes and turned the money over to him. When Baldwin left the notes with Hinds, he gave as a reason that he had had trouble in Syracuse, and might have trouble in collecting. On the morning of the examination of this witness, Hinds paid over to Baldwin, the bankrupt, \$100, which he received from Dr. Baldwin the previous November on one of these notes, and had held in his own hands. Just why he held it, does not appear. This was paid Baldwin by Hinds at the hotel in the presence of Mrs. Gay, and Baldwin then handed it to Mrs. Gay. This occurred about three months after the petition was filed. February 5, 1901, after one of the Dr. Baldwin notes had been paid to Hinds, Hinds & Son gave to Charles N. Baldwin a paper of which the following is a copy: "\$211.70. We owe Charles Baldwin \$211.70 for G. E. Baldwin's notes transferred to us. [Signed] W. H. Hinds & Son." Baldwin, the bankrupt, says that in April following (he fixes no date) he wrote the following on that paper, "Pay the above demand to Abby M. Gay," and delivered it to her. But the money collected by Hinds of Dr. Baldwin was not paid to Mrs. Gay, but to Charles N. Baldwin, and then handed over to her. The whole transaction is suspicious, and the evidence that this property was transferred to Abbie M. Gay is far from satisfactory. Why was Hinds, the employer of Baldwin, holding onto this money during the pendency of this proceeding for a discharge? Why was it paid over at a hotel on the very eve of Mrs. Gay's examination? Why was Baldwin, the bankrupt, present when it was paid over, and why was it paid to Baldwin, and not to Mrs. Gay? How is it that Mrs. Gay shows such ignorance of this Hinds duebill or memorandum of indebtedness, if it was delivered to her in April, 1901, and kept by her until paid? She could not tell who signed it. It may be instructive to know where and how Mrs. Gay obtained her clothing, etc., from March, 1885, to May, 1899, if she received no pay for her work, and had no income from other sources, of which there is no pretense. Why was it that Mrs. Gay exacted a note for the borrowed money, and said nothing as to the \$2,184 due her for work, labor, and services? Substantially the whole of Baldwin's property passed into the hands of Mrs. Gay in alleged part payment of a stale and doubtful claim, of which no outside parties had knowledge, shortly before the petition in bankruptcy was filed.

This matter should go back to the same referee for a further hearing, if either party desires to produce additional testimony. The objecting creditor may file within 20 days amended specifications of objections, and the referee will report his findings of fact and conclusions of law, separately stated. A copy of any amended specifications will be served on the attorney for the bankrupt, who may demur to same, or move before the court to make them more definite and certain, within 10 days thereafter, in default of which all objections thereto will be deemed waived. It is so ordered.

DAVID et al. v. LEVY et al.

(Circuit Court, D. Rhode Island. January 10. 1903.)

No. 2,613.

1. TRUST—SUIT TO ESTABLISH—SUFFICIENCY OF BILL.

Allegations in a bill that in 1759 a number of persons of the Jewish faith in Newport, being desirous of establishing and owning a permanent place whereon they could erect a synagogue and conduct their worship according to the Jewish rites, purchased a tract of land, which was conveyed to three persons named, by a deed which contains no declaration of trust, and that a synagogue was erected thereon soon afterward, which has since been used as a place of public worship, do not support a further allegation that the grantees in the deed became joint tenants of the premises as trustees "for the Jews of Newport"; nor do they show in the complainants, who sue as individuals, conceding them to be "Jews of Newport," any interest in the property, legal or equitable.

2. EQUITY—GROUNDS FOR RELIEF—PROTECTING POSSESSION OBTAINED BY FORCE.

Complainants cannot invoke the aid of a court of equity to maintain them in the possession of property which they took by force from defendants, who are conceded to have been in possession under a deed purporting to convey to them the legal title, by enjoining defendants from prosecuting an action at law for its recovery.

In Equity. On demurrer and plea.

John C. Burke, Clark Burdick, and Max Levy, for complainants.
James Tillinghast and Wm. P. Sheffield, Jr., for respondents.

BROWN, District Judge. The bill alleges, in substance, that in 1759 a tract of land in Newport was purchased by a number of persons of the Jewish faith, and that a deed of said land was executed by its owner, Ebenezer Allen, to Jacob Rodriques Rivera, Moses Levy, and Isaac Harte, all of Newport. This deed, which is annexed to the bill, is upon its face a deed to the grantees named for a full money consideration, and affords no evidence in itself of the allegation of the bill that the said grantees "became joint tenants of said parcels of land as trustees of the Jews of Newport, forever"; nor would such a trust arise from the fact that certain persons of the Jewish faith had contributed the purchase money from a desire "of establishing and owning a permanent place whereon they could erect a synagogue, and conduct their worship according to the Jewish rites." Aside from the question whether such a trust as is alleged in the bill—i. e., a trust "for the Jews of Newport"—would be a valid trust, and, if valid, enforceable by these complainants, it is apparent that no trust of this general character would arise from a purchase of the land for the purposes set forth in paragraph 1 of the bill. On the complainants' own theory of a trust for the Jews of Newport, the bill is fatally defective, for its omission to set forth that any one of the complainants is a Jew; and it is difficult to imagine how the "Congregation Jeshuat Israel, a corporation created by law," can be regarded as having any right or interest in such a trust, since a domestic corporation of this state cannot be regarded as a "Jew of Newport." Assuming, however, that there is an omission by mere oversight, and that the 14 individual complainants are Jews,

the bill is still fatally defective for its failure to allege any facts which would give them any legal or equitable interest in the land or building in question. If lands were purchased in 1759, and a synagogue erected thereon in 1763 by Jews then residing in Newport, and even if the synagogue has ever since been used as a place of public worship, this would not support the present bill. Paragraph 11 of the bill contains the averment that the defendants "have interrupted the possession, the control, and management of said premises by the Jews of Newport, with which, as a matter of law and equity, they were invested." This is a mere allegation of a legal conclusion for which there is no warrant in the facts stated in the bill, and with which such facts as are stated are inconsistent.

The purpose of certain paragraphs of the bill is not apparent. The extract from the will of Jacob Rodriques Rivera, deceased February 18, 1789, contains a recital which may be interpreted as declaring that the conveyance to Rivera, Moses Levy, and Isaac Harte was "in trust only to and for the sole use, benefit, and behoof of the Jewish Society in Newport." He, moreover, released all right, "always saving and excepting such right as I have by being a single member of that society." So far as this tends to show a trust, it is a trust for a Jewish society, and not the trust set forth by the complainants, to wit, a trust for the Jews of Newport. There is no allegation that these complainants have any standing as members of a Jewish society, or as persons entitled to admission thereto, or even that they have the right to demand of such society or its trustees the right to attend worship.

But, in addition to the entire failure of the complainants to set forth any legal or equitable interest as the basis of this bill, it appears by the bill that the defendants were in actual possession, under deeds purporting to convey them a legal title, upon a trust declared therein, and that the complainants entered the premises for the purpose of holding religious services, and are now, and have been since April 22, 1902, in the full, free, and uninterrupted possession, and have been sued in the state court in an action of forcible entry and detainer, and that the complainants seek to enjoin the prosecution of actions at law. The bill discloses no reason for enjoining the defendants from establishing their title at law, or which justifies the complainants in their present alleged possession and control of the premises. The plea of the defendants to paragraphs 14 and 15 sets forth, however, that the complainants' entry and possession were by forcible entry and detainer, which is a bar to the right of the complainants to seek the aid of a court of equity, even though the verdict set forth in the plea is of no legal force. The complainants cannot take the law into their own hands, acquire possession by force, and then invoke the aid of a court of equity to maintain them in a possession which, so far as appears from the bill, is without legal or equitable justification, and which appears by the plea to have been obtained by forcible entry and detainer.

Demurrer sustained, plea sustained, and the bill will be dismissed.

FENNO et al. v. PRIMROSE et al.

(Circuit Court of Appeals, First Circuit, January 7, 1903.)

No. 429.

1. AUDITORS IN ACTION AT LAW—POWER OF FEDERAL COURT TO APPOINT—COMPENSATION.

A circuit court of the United States has inherent power to appoint an auditor in any action at law, in the exercise of its discretion, where the issues or the items involved are so numerous or complex as to render a proper understanding of the controversy by the jury impossible until they have been simplified; and, where the state practice in respect to the compensation of the auditor is such that it cannot be followed by a federal court,—as where a statute provides for his payment by the county,—the court may direct the expense of the auditor trial to be borne by either or both the parties, in its discretion, as in case of masters in chancery, having regard to all the circumstances of the particular case.

In Error to the Circuit Court of the United States for the District of Massachusetts.

See (C. C.) 116 Fed. 49.

Moorfield Storey, Ezra R. Thayer, and Sydney R. Wrightington, for plaintiffs in error.

Sherman L. Whipple and Hugh W. Ogden (Whipple, Sears & Ogden, of counsel), for defendants in error.

Before COLT, Circuit Judge, and ALDRICH and BROWN, District Judges.

ALDRICH, District Judge. The questions presented in this case are of exceeding interest and of great practical importance to the profession and to litigants, and they have been discussed upon both sides with notable ability and commendable thoroughness. They relate—First, to the power of a federal court to appoint an auditor in an action at law, where the parties are entitled, under the constitution, to a jury trial; and, second, to the power of such a court to regulate the compensation of the auditor, and to determine where the burden of such compensation shall rest.

There is no federal statute authorizing the reference of an action at law to an auditor, nor is there any statute providing for compensation by placing the burden either upon the government or the parties.

In this case the plaintiffs in error, who were the prevailing party, and who have paid one-half of the auditor's fees, claim the right (there being no question about the reasonableness of the fees) to tax the amount paid the auditor in their bill of costs against the defeated party, and that the right to so tax it is an absolute right.

At the bar there was considerable discussion of the question whether the right of the prevailing party to costs depends upon section 721 or section 914 of the Revised Statutes [U. S. Comp. St. 1901, pp. 581, 684], and of the question as to how far the federal courts should conform to the state laws and the state practice in matters of this kind. Under the peculiar circumstances of this

case, however, the discussion in this respect does not aid in the solution of the question presented, for the reason that the courts of general jurisdiction in Massachusetts at the present time are governed by a statute (Rev. Laws Mass. c. 165, §§ 55, 60) which provides for reasonable compensation to auditors, and that it shall be paid by the county. So, in the absence of a federal statute clothing the federal courts with authority to place the burden upon the government, as is now done by the Massachusetts courts of general jurisdiction, we are confronted with a situation in which the federal courts cannot conform their practice to that of the courts of the state. The Massachusetts statute referred to (section 55) provides that "the supreme judicial court, or the superior court, in its discretion, and a police, district or municipal court, if both parties assent thereto in writing, may appoint one or more auditors," etc.; and it will therefore be seen that the courts of general jurisdiction may, under this statute, act in their discretion, without regard to the assent of the parties, while the inferior courts may appoint upon assent in writing by both parties; and, where it is done by the higher courts in the exercise of discretion, the statute (section 60) not only contemplates that the compensation of the auditor shall not be taxed as costs against the defeated party, but expressly requires it to be paid by the county, while, if done by the inferior courts upon assent in writing, the statute contemplates that the fees may be paid by either party, and taxed in the bill of costs.

We must assume, therefore, in this case, so far as the state practice bears upon the situation, that the lawmaking power of Massachusetts, acting under the injunction of article II of part I of the constitution of Massachusetts, and upon grounds of public policy, that every subject ought to find a certain remedy and obtain right and justice freely, has, so far as the appointment of auditors without consent of the parties in writing is concerned, declared against the idea of placing the burden incident to an auditor's trial, under an absolute rule, upon the defeated party, as taxable costs in favor of the prevailing party.

The intention, as it seems to us, of the Massachusetts statute, is quite apparent. It was intended, in that class of cases where the parties assent in writing, thereby selecting their own tribunal, that the burden of a reasonable compensation to the auditor should be taxed as costs against the defeated party, while in that class of cases where the court, by virtue of its inherent or statutory power, creates an auditor tribunal without the consent of the parties, that the expense shall not be taxable as costs, and that the burden shall fall upon the county. So having reference, therefore, to the present law and practice of the state in the higher courts, to which we should conform our practice, in a reasonable way, in proper cases, we find no warrant for taxing auditor's fees in this case against the defeated party; nor should we find warrant for so doing were we to look to the practice of the inferior courts, for the statute with reference to such courts is based upon the assent of the parties in writing, which does not exist in this case.

It does not necessarily follow, however, that, because the state practice places the burden upon the county under a somewhat recent

Massachusetts statute authorizing it, a federal court, exercising jurisdiction over a case in which an auditor is necessary in order that justice shall be administered, has not the power to appoint an auditor, and direct where the burden shall rest, merely for the reason that there is no federal statute authorizing the court to order the expense to be paid by the government. The rule, however it may be construed, which requires us to follow the practice of the state court, is not so absolute or drastic that, because the practice under a state statute is to place the burden upon the county,—a rule which we cannot follow,—we should decline to administer justice in a case within our jurisdiction because it is impossible for this court in that respect to conform its practice to that of the state court. This being so, it becomes necessary for us to inquire what the inherent power of the federal court is in a situation like the one in this particular case.

Where a case within the jurisdiction of the court is presented, and the parties are entitled under the constitution to a jury trial, and where the accounts are so numerous and confused that it would be impossible for a jury to comprehend and intelligently decide it, by reason of the complexity and diversity of the issues and items, unless they are simplified by a preliminary investigation, and where for that reason it would be impossible for the court to administer justice between the parties unless such preliminary investigation and simplification are had by way of preparing the case for the ultimate tribunal, it cannot be possible that the power of the federal court to do justice hangs solely upon the question whether there is a practice in the state court that the fees or compensation of such preliminary investigation may be taxable as costs. Under such conditions, and in the absence of a federal statute, we have no doubt of the power of the circuit court to direct a preliminary investigation in a proper case, and to designate a suitable person as an officer of the court to call the parties before him, as a tentative tribunal, to simplify the items and the issues in order that the case may be intelligently presented to a jury.

A rule which would withhold such power from courts charged with the duty of ascertaining and establishing the rights of litigants would operate as a denial of justice in a certain class of cases. If the power exists as a necessary incident of judicial procedure, authority and power to provide for the expense of such a preliminary investigation necessarily exist as well. The duty is upon the government to provide a tribunal for the establishment of disputed rights, and courts and juries are provided for such purpose; but, if contending parties come with a case involving items and issues so complex that a jury cannot comprehend and carry them, the misfortune is that of the parties. It may be the misfortune of one or both of the parties, and under such circumstances the court may devise such means for preliminary investigations and simplifications as the necessities of the situation and justice may require. An arbitrary and absolute rule, however, casting the entire burden of such preliminary expense upon the defeated party, might operate unjustly, and might cast an

excessive and unreasonable burden upon the party upon whom the burden should not rest.

For the reasons stated, we cannot look for guidance to the cases in the federal courts where auditors have been appointed and the fees taxed in accordance with a state practice based upon a state statute; and we are thus compelled to consider this case not only in the absence of a federal statute, but independent of a state practice, and of federal decisions based thereon, as well, and determine the questions presented by reference to the inherent and necessary power of courts charged with the administration of justice in cases where a preliminary or tentative investigation becomes a necessity.

It is of little consequence whether the official designation of the person charged with such investigation is that of "commissioner," "auditor," "accountant," "assessor," "examiner," or "master," although, as is well known, the ordinary designation in actions of law is that of "auditor," while in proceedings in equity it is that of "master."

In cases at law, with numerous confused items and issues, where the ultimate right of trial by jury exists, in order to simplify the issues, such a preliminary trial or investigation may and oftentimes does become a necessary step incident to the preparation of the case for the ultimate tribunal, the jury. All this is to the end that the case may be intelligently presented to and understood by the ultimate tribunal. The situation may be such that it is necessary for the plaintiff's side alone, or, on the contrary, for the defendant's side alone, or the situation may be such that it is necessary for both sides. If it were a case where the plaintiff's items were two or three, so far as his side of the case would be concerned there would be no difficulty in the jurors carrying the items, and the evidence relating to them, in their minds, and there would be no occasion for an auditor so far as that side of the case would be concerned, while in the same case the defendant's items might be so numerous, and the accounts so confused, and the minor issues involved so multiplied, that his side of the case could not be intelligently presented to the jury until the items and the issues had been simplified by some preliminary investigation, in which both parties, of course, should be represented, and the exigencies of his side of the case would be such as to require an auditor. Such requirement would thus result from an inherent necessity in the defendant's case,—a necessity that his case should be put in such form as to be passed upon by another tribunal,—and for this reason it might be inequitable and unjust to place upon the plaintiff the entire expense incident thereto, under an arbitrary and absolute rule, although he may be the defeated party; and it is for this reason that it should not be governed by an absolute rule.

An absolute rule, under such circumstances, would not be adopted by courts in the absence of an express statute.

The doctrine which authorizes the appointment of such a preliminary tribunal is one of judicial necessity, and the exercise of authority in that direction is based upon a finding, under rules of legal discretion, that the case cannot be dealt with intelligently in its then condition, and under the same necessity, and under guidance of the same rules of discretion, the court may ascertain and determine where the burden of

such an investigation shall rest. And all questions as to the occasion for the preliminary investigation and all questions as to the burden of expense must be determined with reference to the necessities and the peculiar circumstances of a particular case, rather than by any arbitrary rule applicable to all cases.

The expenses of such a trial and investigation are not the ordinary expenses of litigation, but result from the order of court based upon necessity, and it should rest with the court on whose order the expenses were incurred to regulate where the burden should rest. Such expenses do not stand like the ordinary legal taxable costs, which are taxable by the clerk as ordinary costs, and which are governed by statute and rules of decision applicable to all cases alike. It should be and it is in the power of the court, in the exercise of a sound discretion, to rest this preliminary burden where it ought to rest, even to the extent, in an extreme case, of putting it all upon the prevailing party if the necessities of that side required the auditor, or of dividing it equally if the situation requires it, or in such other way as it ought to be divided under the circumstances of a particular case. And the end may be accomplished by ordering it taxed in the costs, or in such other way as is found to be just. This is so because the trial is not by the ultimate tribunal. It is merely a step in the direction of putting the case in shape for presentation to the ultimate tribunal.

The unquestioned power of courts to appoint auditors in a very limited class of cases has existed from an early period in England and in this country. It was at first exercised in England in the common-law action of account, where, according to Bacon, "the accounts be of a long and confused nature"; and the power has expanded, by statutory provisions and under the rules of the common law, as exigencies have arisen, so as to include other forms of action, and perhaps it may be said all forms of action where the accounts, and the issues in respect to the items thereof, are so numerous as to render a proper understanding of the controversy impossible by a jury until the issues have been simplified.

The power to appoint auditors was at first exercised in England independent of statute, and has been from time to time enlarged and regulated by statutory enactment.

It is a matter of common understanding that, in cases where the items are numerous and the issues complex, one party alone is without the means to simplify and reduce the issues, while if both parties are before an auditor or master, with an opportunity to offer proofs and to explain, the minor issues and disputes disappear. And thus it is that a tentative trial before an officer of the court appointed for such a purpose is a useful step in the direction of simplifying the situation, and putting the case in proper form to be presented to the ultimate and conclusive tribunal.

Power to appoint an auditor in a proper case does not necessarily rest upon statutory provisions. *Davis v. Railroad Co.* (C. C.) 25 Fed. 786. Such power was a necessary incident of common-law procedure. Although in many of our states authority to appoint auditors is expressly conferred by statute, and although compensation is variously provided for in the different states, we look upon such legislation as

largely declaratory and regulatory of the common-law power. Thus such legislation is a recognition of the common-law power, rather than the creation of a new power. In jurisdictions where statutory provision is made, the auditor trial or preliminary investigation would doubtless ordinarily be in accordance with the statutory regulations, while in jurisdictions where there are no statutory provisions relating to auditors the power exercised would be under the principles of the common law. The application of these principles of the common law, however, would not necessarily be limited to the form of action or the class of cases in respect to which such power had been exercised in the past; but the principle may reasonably enough, we think, be applied to any form of action or any case which presents a situation so intricate and so complex that it cannot be intelligently understood and decided by a jury until the items or the issues shall have been simplified. Such an investigation involves no infraction of the constitutional right of trial by jury, because it does not assume to be conclusive. It is only tentative, and is under such circumstances a necessary preliminary, and the necessary and only means of approach to the constitutional right of trial by jury.

Although the jurisdiction of federal courts is special and limited, procedure therein, unless regulated by statute, must necessarily, in respect to cases within the jurisdiction of such courts, expand upon conservative lines to meet exigencies created by new conditions, to the end that they may administer the rights of the parties upon principles of justice not conflicting with the rules of the common law. Although not strictly analogous, it is undoubtedly within the power of the court, and the power is often exercised during a jury trial where the accounts are confused or complex, to order an accountant to go through the books and papers, and state the result of his computations to the jury. This is, of course, tentative, and all subject to attack in the same trial, and the expense thereof may be made to rest where the justice of the particular case requires that it should rest.

This case must be altogether distinguished from that class of cases where the order for an auditor was made upon assent of the parties, or upon motion of one of the parties. According to the record, the order in this case was made by the court upon its own motion, and no question is made but that it was a proper case for the exercise of such a power.

The auditor expense was a burden compulsorily cast upon the parties, and does not stand, therefore, as already said, like expense voluntarily incurred by a party in the ordinary preparation and presentation of his case, but is an expense cast upon the parties by reason of an inherent necessity of preparation and simplification, involved in the situation, and is therefore, while not precisely the same in principle, in substance, like the case of *Whipple v. Manufacturing Co.*, 3 Story, 84, 86, Fed. Cas. No. 17,515, where a survey was ordered by the court by way of preparation, and was for the mutual benefit of the parties, and necessary to the true understanding of the cause on both sides, and where the expense was divided equally between the parties, or like *Land Co. v. Tilton* (C. C.) 29 Fed. 764,

where the expense of a survey ordered by the court was necessary to the defendant's case alone, in order to perfect his pleadings, and where, although the prevailing party, he was not allowed to tax the expense of the survey as costs, and the burden was made to rest upon him alone.

In a somewhat recent case (*Brickill v. City of New York* [C. C.] 55 Fed. 565, 566), Judge Lacombe, of New York, adjusted a master's fees between the parties upon the basis of the time occupied by each party before the master; reserving the right to impose the entire expense upon the defeated party.

In short, we look upon a preliminary examination, in a case where the parties are entitled to a jury trial, and where, therefore, the preliminary examination before the auditor or commissioner is merely tentative, and for the purpose of stating the accounts or simplifying the issues, as one involving the exercise of legal discretion, both as to the necessity of the preliminary trial and the expenses thereof. From the very nature of the situation, the question whether an auditor or commissioner trial is needed must necessarily be determined by the court in the exercise of legal discretion, and the question as to where the burden of the resultant expense should rest not being regulated by statute, and being of a nature not susceptible of a general rule applicable to all cases alike, that, as well, becomes a question to be settled by the court in the exercise of sound judicial discretion.

It is difficult to see that the expense of an auditor trial, where necessary and proper, stands upon a different rule or a different principle than that of a master in chancery, where a master is necessary, and in respect to which compensation is to be allowed, under rule 82 of the rules of practice for the courts of equity of the United States, in a particular case by the circuit court in its discretion, having regard to all the circumstances thereof, and where the "compensation shall be charged upon and borne by such of the parties in the cause as the court shall direct."

The court below determined for itself the question of necessity, and the question as to where the resulting expense should be made to rest. The determination of both these questions involved the exercise of a discretion with which we would not be justified in interfering upon the facts disclosed by the record.

We are not unmindful of the fact that in this particular case the preliminary investigation proved of no benefit to the parties. It is quite probable, if the defendants below had taken the point that the case had advanced so far that the plaintiffs were not entitled to a nonsuit without prejudice, that the benefit of the preliminary investigation would have been saved to the parties. *Hershberger v. Blewett* (C. C.) 55 Fed. 170; *City of Detroit v. Detroit City R. Co.*, Id. 569; *American Bell Tel. Co. v. Western Union Tel. Co.*, 16 C. C. A. 367, 69 Fed. 666; *Pullman's Palace Car Co. v. Central Transp. Co.*, 171 U. S. 138, 18 Sup. Ct. 808, 43 L. Ed. 108.

We cannot, however, deal with such phase of the case, for the question is not raised by the record.

Whether the defendants below have a remedy by application to the circuit court to strike off the entry of nonsuit when the case and the

parties are again there is a question for that court, and one which we cannot determine upon the present record.

Judgment of the circuit court is affirmed, with costs.

BUSTON v. PENNSYLVANIA R. CO.

(Circuit Court of Appeals, Third Circuit. January 19, 1903.)

No. 12.

1. CARRIERS OF GOODS—CONNECTING CARRIERS—DUTY IN RESPECT TO FORWARDING.

An intermediate carrier, who receives goods to be carried to a point short of their final destination, is bound only to use reasonable diligence to secure further transportation by tendering them to the connecting line, and, if acceptance be refused, then to notify the consignor or consignee without unreasonable delay, and store or otherwise care for the goods while awaiting instructions. Having done this, its liability as a carrier will cease, and liability as a warehouseman be substituted.

2. SAME.

Defendant railroad company received cotton from a connecting carrier, to be transported over its line, and delivered to a steamship company for further shipment. Before it was tendered, fire broke out in two of the cars, and on a subsequent tender the steamship company refused to receive it, deeming it in unsafe condition, and the steamer on which it was to be shipped sailed without it. Notice was promptly given to the shipper, and instructions asked for, but none were given. Defendant again offered the cotton to the steamship company to be taken on a later vessel, but, another fire having occurred before the time for sailing, the company definitely refused to take it. The owner was again notified, and, no instructions being received, defendant stored the cotton subject to the owner's order, having held it over a month. Defendant was in no way responsible for the fires nor for the condition of the cotton. *Held*, that it had discharged its duty by tendering the cotton to the connecting carrier, and notifying the owner of its refusal, and was not required to put it in condition and again tender it, but was justified in storing it to await the owner's orders.

In Error to the Circuit Court of the United States for the Eastern District of Pennsylvania.

For opinion below, see 116 Fed. 235.

Samuel Dickson and R. C. Dale, for plaintiff in error.

Frank P. Prichard, for defendant in error.

Before ACHESON, DALLAS, and GRAY, Circuit Judges.

ACHESON, Circuit Judge. On July 19, 1900, the New York, Philadelphia & Norfolk Railroad Company contracted with the agents of R. A. Lee & Co., of Charlotte, N. C., for the transportation of 300 bales of compressed cotton from Norfolk, Va., by rail to Philadelphia, and thence by steamer of the American Line, appointed to sail on August 11, 1900, to Liverpool, England. Accordingly, the said railroad company afterwards issued its through bills

¶ 1. See Carriers, vol. 9, Cent. Dig. §§ 750, 755.

of lading for the cotton, of which 50 bales were consigned to the order of H. B. Moses, Liverpool, and the remaining 250 bales were consigned to the order of R. A. Lee & Co., Liverpool, "to be carried to the port of Philadelphia, and thence by the American Line to the port of Liverpool." On or about August 6th the initial carrier, the New York, Philadelphia & Norfolk Railroad Company, delivered to the defendant the Pennsylvania Railroad Company, at the point of connection with its road, the cars containing said cotton for transit to Philadelphia. The original cars containing the cotton reached the terminal of the Pennsylvania Railroad adjacent to the wharves of the American Line on the Delaware river on or before August 7th, and there stood with certain other cars of the same train, containing cotton shipped by J. E. Gilbert & Co., under independent contracts, destined for carriage by the same steamer of the American Line that was to take the cotton of R. A. Lee & Co. On August 7th a fire broke out in one of the cars containing bales of the Gilbert cotton. It was promptly extinguished. On the next day another fire broke out in a car containing 50 bales of the R. A. Lee & Co. cotton. This also was promptly extinguished. In each case the fire began inside the car, and there was no evidence whatever that either of the fires originated through any cause for which the carriers were in any wise responsible. This the learned judge below states in his opinion, and the statement is fully warranted by the proof. Upon the occurrence of these fires the defendant informed the agents of the American Line of the facts. On August 10th the defendant made an actual tender of the cotton here in question (the 250 bales of the Lee cotton) to the agents of the American Line, in time for the delivery of the whole of it before the departure of the vessel, which was to leave on August the 11th. The agents of the American Line declined to receive this cotton on the ground that it was dangerous, and the steamer, on the 11th of August, left without the cotton. The defendant gave prompt notice of the facts to the initial carrier, the New York, Philadelphia & Norfolk Railroad Company, "requesting orders for disposition," and through the original carrier R. A. Lee & Co., the shippers, were promptly notified of the facts. The defendant, not having heard from the initial carrier or the shippers as to the disposition of the cotton, applied to the American Line to know whether it could go forward on its next scheduled steamer, and in reply, by letter dated August 27th, the American Line, while insisting that it had contracted only for the steamer of August 11th, and that the contract was at an end, offered to carry the cotton on its steamer, the *Ikbal*, appointed to sail on September 15th, provided, upon an examination by an expert, the cotton was found free from danger; the shippers to bear one-half of the expense of the expert examination. The defendant immediately telegraphed this offer to the initial carrier, by whom it was communicated to the shippers, R. A. Lee & Co., but neither made any reply to the telegram. A third fire having occurred on September 2d in another of the cars containing bales of the Gilbert cotton, the American Line, by its authorized agent, sent the following notification to the agent of the defendant company:

"International Navigation Company.**"Philadelphia, September 6, 1900.**

"Mr. F. H. Meyers, Philada.—Dear Sir: Since my letter of August 27th, offering to enter into a new arrangement, and carry forward the cotton on the next voyage of the Ikbal, provided it was proven free from danger, another fire has occurred on September 2d on car N. & W. 20,388, which, from all the attendant circumstances, the entirely spontaneous nature of the fire occurring inside a loaded car, the long period elapsing before it manifested itself, etc., indicates such a dangerous condition in the cotton that we cannot now, in safety to our ships, carry it forward under any circumstances. We regret that such is the case, and had hoped, prior to this last fire, that all further danger had passed.

"Yours truly, Lee R. McKinstry, East-Bound Freight Agent."

The defendant sent prompt notice directly to R. A. Lee & Co. of this refusal of the American Line to carry the cotton forward under any circumstances, and urged them to take steps to dispose of the cotton, and to act at once. By letter of September 13th, R. A. Lee & Co. informed the defendant that they could not interfere, because (as they stated) they had sold this cotton to A. J. Buston & Co., of Liverpool (the plaintiff); and they further stated in their letter: "Mr. A. J. Buston sailed from Liverpool on the 7th inst. for New York, and we wired him at New York to-day to call at Philadelphia on his way south to look after this cotton." Not having received any instructions as to the disposition of this cotton, the defendant, on September 18, 1900, caused it to be stored for safe-keeping in the warehouse of D'Olier & Co., in Philadelphia. Before putting it into the warehouse, D'Olier & Co. examined the cotton, to see whether it was safe to take on storage, and, finding it to be free from danger, stored it in their warehouse, where it was thereafter kept ready for delivery to the owner or upon his order. R. A. Lee & Co., it appears from the evidence in this case, had drawn drafts (with the bills of lading indorsed and attached) on the plaintiff for the value of the cotton here in question, and these drafts the plaintiff accepted in Liverpool in ignorance of the fire, and subsequently paid them. On or about August 12th the plaintiff heard by cable in Liverpool that the 50 bales of cotton had been burned. The steamer of August the 11th arrived at Liverpool while the plaintiff was there, without any of the cotton, and this the plaintiff then knew. He testifies that he sailed from Liverpool to New York on the 4th or 5th of September. Upon his arrival in New York (and certainly before September 20th) the plaintiff was fully informed of all the facts touching this cotton. Mr. Lee, of the firm of R. A. Lee & Co., and Mr. Putnam, an insurance adjuster (both of whom knew of the storage of the cotton with D'Olier & Co.), met the plaintiff in New York, and advised him of all the circumstances. As early as September 20, 1900, the plaintiff had the fullest information of all that had occurred. Thereupon he took the position that he had nothing to do with the cotton until it was delivered to him in Liverpool, and claimed that R. A. Lee & Co. were bound to have it delivered to him there. Upon this point a dispute at once arose between the plaintiff and the shippers of the cotton. The plaintiff also set up a claim for the value of the cotton against the insurers. The

plaintiff gave no instructions whatever to the defendant; neither did the shippers; and the cotton remained on storage in the warehouse of D'Olier & Co. until the time of the trial of this case in April, 1902.

The facts, as hereinbefore stated, were shown by uncontradicted evidence, all of the evidence in the case coming from the plaintiff's side. This suit was brought on December 10, 1901, by A. J. Buston, doing business under the name of A. J. Buston & Co., against the Pennsylvania Railroad Company, to recover the sum of \$12,828.80, which the plaintiff had paid for the 250 bales of cotton, and also special damages alleged to have been sustained by him "by reason of the action of the defendant in not forwarding the cotton."

The relation of the defendant to this cotton was altogether that of an intermediate carrier between the initial carrier, which issued the through bills of lading, and the American Steamship Line, which was to carry the cotton from Philadelphia to its ultimate destination. The defendant had not entered into any engagement whatever binding it to transport the cotton beyond its terminus adjacent to the wharves of the American Line on the Delaware river. Upon accepting the cotton from the initial carrier, the defendant's duty was to safely transport it to the point of connection with the American Steamship Line, and there tender the cotton to that line. This the defendant did. It made an actual and timely tender of the cotton to the American Line. The tender was refused because of the supposed dangerous condition of the cotton. The defendant promptly notified the initial carrier, and, through it, the shippers, of the facts, and asked for instructions. No instructions came. In response to an inquiry of the defendant, the American Line made an offer to carry the cotton on its next outgoing steamer, upon certain conditions. This offer was immediately communicated to the shippers, but no reply was made. Then the American Line notified the defendant that it would not, under any circumstances, carry the cotton. The defendant sent prompt notice of this peremptory refusal to the shippers, and called on them to act. Now, the shippers of this cotton were also the consignees thereof. The first information of the plaintiff's title came to the defendant in the shipper's letter of September 13th, in which the shippers wrote that the plaintiff had sailed for New York, and that they had wired him there to come to Philadelphia, and look after the cotton. This was the situation on September 18th,—more than a month after the tender and refusal,—and we think that, in the absence of instructions from any quarter, the defendant was fully justified in depositing the cotton for safe-keeping in the warehouse of D'Olier & Co., to await instructions. The general rule of law is that an intermediate carrier, who receives goods to be carried to a point short of their final destination, is bound only to use reasonable diligence to secure further transportation by tendering them to the connecting line, and, if acceptance be refused, then to notify the consignor or consignee, without unreasonable delay, and store or otherwise take care of the goods while awaiting instructions. Having done this, the liability of the carrier as such will cease, and the liability of a warehouseman be substituted. Elliott, R. R. §§ 1432, 1449; Schouler, Bailm. & C. § 609; Johnson v. Railroad Co., 33 N. Y. 610, 612, 88 Am. Dec. 416; Rawson v. Holland,

59 N. Y. 611, 615, 17 Am. Rep. 394. Upon the indisputable facts this case falls within the rule of law just stated. Whether or not the American Line had good cause for refusing to accept the cotton when tendered is immaterial here. The defendant was in no wise responsible for the actual or supposed condition of the cotton. The defendant was free from fault. There is not a particle of evidence tending to show that any of the mentioned fires occurred through negligence or want of proper care on the part of the defendant. So far as the defendant was concerned, its tender of the cotton to the connecting carrier on August 10th was good. We are not then able to adopt the view, expressed by the learned judge below, that the defendant was bound to make another tender of the cotton after D'Olier & Co. had made their examination and pronounced it free from danger. The examination was made by the warehousemen for their own safety. It was not the expert examination which the American Line had proposed in the offer which the shippers would not accept. Moreover, by its letter of September 6th, the American Line had notified the defendant that it would not carry the cotton under any circumstances. Certainly, in the face of that absolute and final refusal, the defendant was not bound to incur the expense and trouble of making a second, and an apparently vain, tender. Then again, the owners of the cotton had contracted for its shipment in the steamer sailing August 11th, and it was not for the defendant, in the absence of instructions, to take upon itself the responsibility of forwarding the cotton more than a month afterwards. *Johnson v. Railroad Co.*, supra. But finally, R. A. Lee & Co., the shippers and consignees of the cotton, and their transferee, the plaintiff, had due notice of all the facts. Both were near at hand,—on the ground, it may be said. The defendant had the right to await instructions from the owner. Indeed, this was its plain duty under the circumstances. It was for the owner of the cotton to direct what should be done with it. The cotton was kept safely stored, subject to the plaintiff's order, and ready at all times to be delivered to him. More than this the plaintiff had no right to ask. Upon his own showing he had no cause of action against the defendant. Therefore the judgment of the circuit court in favor of the defendant was rightly rendered, and, for the reasons expressed in this opinion, is affirmed.

STOCKLEY v. CISSNA.

(Circuit Court of Appeals, Sixth Circuit. November 10, 1902.)

No. 1,088.

1. STATE BOUNDARIES—CHANGE OF RIVER CHANNEL BY AVULSION.

The sudden cutting of a new channel by the Mississippi river in 1876, called "Centennial Cut-Off," across Devil's Elbow Bend, by which several thousand acres of land within the bend, and formerly on the eastern bank of the river, is left on the western bank, in consequence of the river's abandonment of the old channel, did not change the boundary between the states of Tennessee and Arkansas, which remained where it was originally fixed,—in the middle of the abandoned channel.

2. DEEDS—RECITALS AS EVIDENCE.

Recitals in a deed of recent origin that the makers are the heirs of a former owner, without circumstances in support, are not evidence against a stranger.

3. EJECTMENT—TITLE TO SUPPORT ACTION—EVIDENCE.

Plaintiff in ejectment proved title in one John T., and introduced what purported to be a copy of his will, devising the land to his son W. W. T., and a quitclaim deed recently executed to plaintiff from persons who recited therein that they were all the heirs of W. W. T., deceased. There was no other evidence of his death intestate, that the grantors were his heirs, or that they were ever in possession of the land. Plaintiff also introduced a decree of a chancery court divesting the title of the parties to the suit to the land in controversy, described as belonging to the estate of John T., deceased, and vesting it in a partnership, through which plaintiff claimed by mesne conveyances; but the decree did not show, nor was there any other evidence to show, who were parties to the suit. *Held*, that neither line of proof showed title in plaintiff which would support the action.

4. ADVERSE POSSESSION—TIME OF COMMENCEMENT—DEED AS EVIDENCE.

A deed may constitute part of the evidence of possession, as showing its extent or characterizing it; but it raises no presumption that an actual possession, such as will start the statute of limitations to running against an adverse claimant, which the grantee is shown to have had at a later date, commenced at the date of its delivery.

5. EJECTMENT—TITLE TO SUPPORT ACTION.

Under the statute of Tennessee (Shannon's Code, §§ 5000, 5001), ejectment cannot be maintained on possessory rights only, although the defendant is a mere trespasser, but the plaintiff must show a perfect legal title, either by derangement from the state, or by evidence of actual occupation under deeds purporting to convey the title for the full term of seven years.

6. SUBMERGENCE OF RIPARIAN LANDS—EFFECT OF RELICTION.

Land bounded by a navigable river, extending to ordinary low-water mark, which is lost by erosion or submergence, is regained to the original owner of the fee when by reliction or accretion the water disappears and the land emerges; and although the erosion or submergence may have extended across the entire tract, and upon the land of an adjoining owner, such owner cannot claim the land upon its reappearance as an accretion to his own; nor has he any claim to accretions beyond the original shore boundary of the submerged tract over the former bed of the river, which inure to the owner of such tract.

7. ADVERSE POSSESSION—LAND CLAIMED AS ACCRETION.

A deed conveyed a tract of land by metes and bounds, and also purported to carry the right to accretions consisting of new land formed by the reliction of the Mississippi river. The legal title to such new land was, however, in another, who owned the same before its submergence. *Held*, that the deed constituted, at most, only color of title to such new land, and that possession and occupancy of the principal tract by the grantor or grantee did not constitute actual possession of the new land, which would operate to set the statute of limitations to running against the legal owner.

8. ACCRETIONS—EJECTMENT TO RECOVER—TITLE TO SUPPORT.

Accretions are apportionable among riparian proprietors according to the lateral lines of the firm land owned by them, and a legal title to such land is essential to support an action of ejectment to recover accretions thereto.

9. EJECTMENT—TITLE TO SUPPORT—GRANT AFTER COMMENCEMENT OF ACTION.

A grant of land by the state of Tennessee relates back to the date of entry, and is sufficient to support an action of ejectment for the land granted, although such action was commenced before the date of the grant, where the entry was prior to the action.

10. BOUNDARIES ON NAVIGABLE STREAM—EFFECT OF SUDDEN CHANGE OF CHANNEL.

Where, by the law of the state, as in Tennessee, lands bounded by a navigable river extend only to ordinary low-water mark, the title to the bed of the river remaining in the state in trust for public uses, land formed gradually by accretion below low-water mark becomes the property of the adjoining owner,—the low-water line remaining his boundary; but, where the stream suddenly abandons its old bed and seeks a new channel, such change works no change of boundary in the lands of adjoining owners, but the title to the land in the abandoned channel remains in the state.

11. NAVIGABLE RIVER—LAND FORMED BY SUDDEN CHANGE OF CHANNEL—GRANT BY STATE.

Acts Tenn. 1847, c. 20, providing for the granting by the state of "vacant lands," does not apply to the bed of the Mississippi river, which many years after the passage of the act became dry land by a sudden change in the course of the river, by cutting a new channel and abandoning the old one,—such land not being vacant land, within the meaning and purpose of the act; and a grant thereof by the land department of the state is unauthorized and void. While the title to such land remains in the state, as before the reliction, it is held for public purposes, and cannot be granted to private persons unless the legislature shall expressly so authorize.

In Error to the Circuit Court of the United States for the Western District of Tennessee.

This is an action of ejectment to recover some 1,200 acres of land described as situated in Tipton county, Tenn. The subject-matter of the suit is land lying substantially between the eastern bank and middle thread of an old and dried-up bed of the Mississippi river. The plaintiff claims the whole of this land, as accretions to land owned by him, originally bounded by the Mississippi river, as well as under a grant from the state of Tennessee to himself for about 1,000 acres thereof, issued in 1901. The declaration sues for the land in controversy as two contiguous tracts, one containing 1,050 acres, or thereabout, and the other 131 acres, more or less. The first or larger tract, which will hereafter be described as the "Island 37 Tract," inasmuch as it is now adjacent to the plaintiff's land on Island 37, is claimed both as an accretion to land on Island 37, and by virtue of the very recent grant from the state of Tennessee mentioned above. The other or smaller tract is now part of Centennial Island, and will be hereafter called "Centennial Island Tract," and is claimed only as an accretion to the plaintiff's land on Centennial Island. The defendant relied upon the general issue of not guilty. After the evidence for both sides had been concluded, the court below instructed the jury to find for the defendant. This instruction has been assigned as error. From the observations made to the jury by the learned trial judge, we are advised that this instruction was predicated upon the supposed invalidity of the grant under which the plaintiff claimed the greater part of the premises, and upon his failure to show a perfect legal title to contiguous lands bounded by the river, to which the parcels in issue were claimed as accretions.

The premises in dispute is a body of new-made land, resulting from a remarkable change in the course of the river by the sudden formation of a new and short channel across the narrow neck of a great bend of the river, known as the "Devil's Elbow," some 30 or 40 miles above Memphis, Tenn. This cut-off channel, now known as the "Centennial Cut," occurred in a single night in March of 1876. The distance by the old channel of the river around the bend was from 15 to 20 miles. The distance across the neck, where the new channel was cut, was somewhat less than 2 miles. The general course of the river in the vicinity of this cut before the new channel was formed is very well shown by a reconnoissance survey made by the war department in 1874, which is set out opposite (Map No. 7).

No. 7.

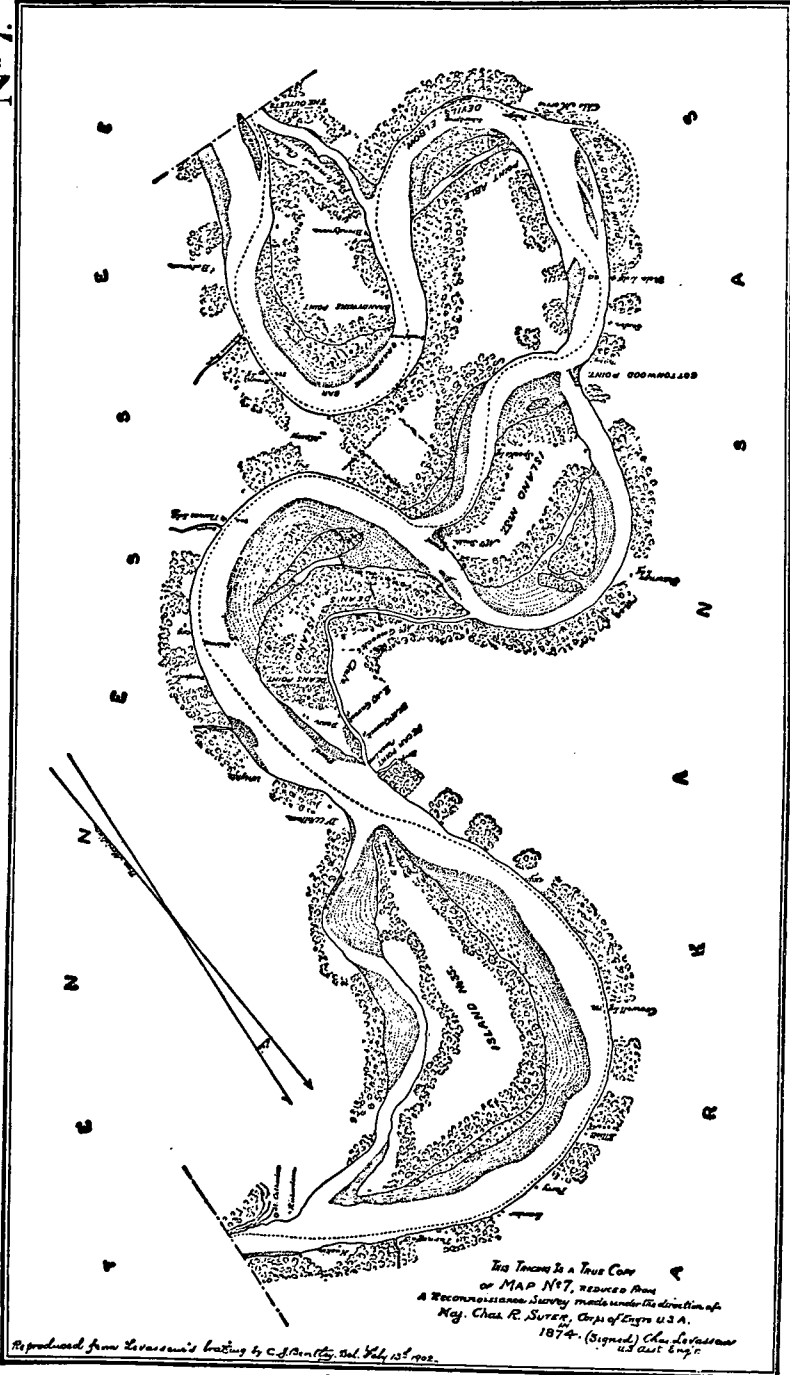

This Town is a True Copy
 of MAP No. 7, reduced from
 a Reconnaissance Survey made under the direction of
 Maj. Chas. R. SUTER, Corps of Engrs U.S.A.
 1874. (Signed) Chas. Stevenson
 U.S. Capt. Eng.

Reproduced from Cassin's drawing by C. J. Bentley, Feb. 15th 1902.

The deep water channel of the river at the date of this map is shown by the dotted black line. The cut-off of 1876 occurred at the point on the map where the neck of the bend is narrowest, and upon which appears the name of "Massey," a then occupant of part of the land which was washed away by the river. The land claimed on the dry land of Island 37 by the plaintiff is about the point indicated by the name "Mrs. Smith," one of the remote grantors under whom plaintiff claims. The elbow cut off from the eastern shore of the old channel by the Centennial Cut-Off constituted for a time an island, and has ever since been known as "Centennial Island." This island was originally separated from Island 37 by McKenzie's Chute, being the channel mediately after the cut-off in favor of the deeper and shorter channel formed by the Centennial Cut-Off, and shown in the map above, east of Island 37. There was evidence tending to show that the main channel of the river around Island 37, as well as McKenzie's Chute, continued to be navigable for possibly one or two or three years by very small boats after this cut-off, but that both channels were substantially abandoned by navigation immediately after the formation of the new channel, and that since about 1880 both channels have gone substantially dry, except in high water; and that Centennial Island, Island 37, and the Arkansas shores constitute now substantially one body of dry land, capable of being crossed dry shod, except in high water. Much of this new land is now grown up in willows and cottonwoods from 18 inches to 2 feet in diameter, and both of the parties to this litigation claim to have fields now in cultivation within what before the cut-off was the bed of the old river.

An official survey of the river made in 1883-84, under the supervision of the Mississippi river commission, shows the new course of the river through the Centennial Cut-Off. This survey is set out opposite (Chart No. 13).

The outlines of old Island 37 are not shown on this map, as the work done by the commission did not include the surface between the northerly lines of Centennial Island, as bordered on what was McKenzie's Chute and the old Arkansas bank of the river. Island 37 is therefore represented on this map by the blank space between the Arkansas shore line and Centennial Island. But to understand the issues involved, it becomes necessary to show the relation of the riparian lands claimed by the plaintiff at the time when they were granted, and at successive periods between his remote and immediate grantors. All of the lands on both Island 37 and Centennial Island were granted by the state of Tennessee about 1823. For the purpose of showing the course and channel of the river as it is supposed to have existed at the time of the old grants under which he claimed, the plaintiff caused a map to be constructed by Mr. J. H. Humphrey, a local civil engineer, in which the banks of the river, as this engineer supposed them to have existed in 1823, are set down from data obtainable from two sources—First, the government survey and plot of the government lands on the west or Arkansas

Chart No. 18.

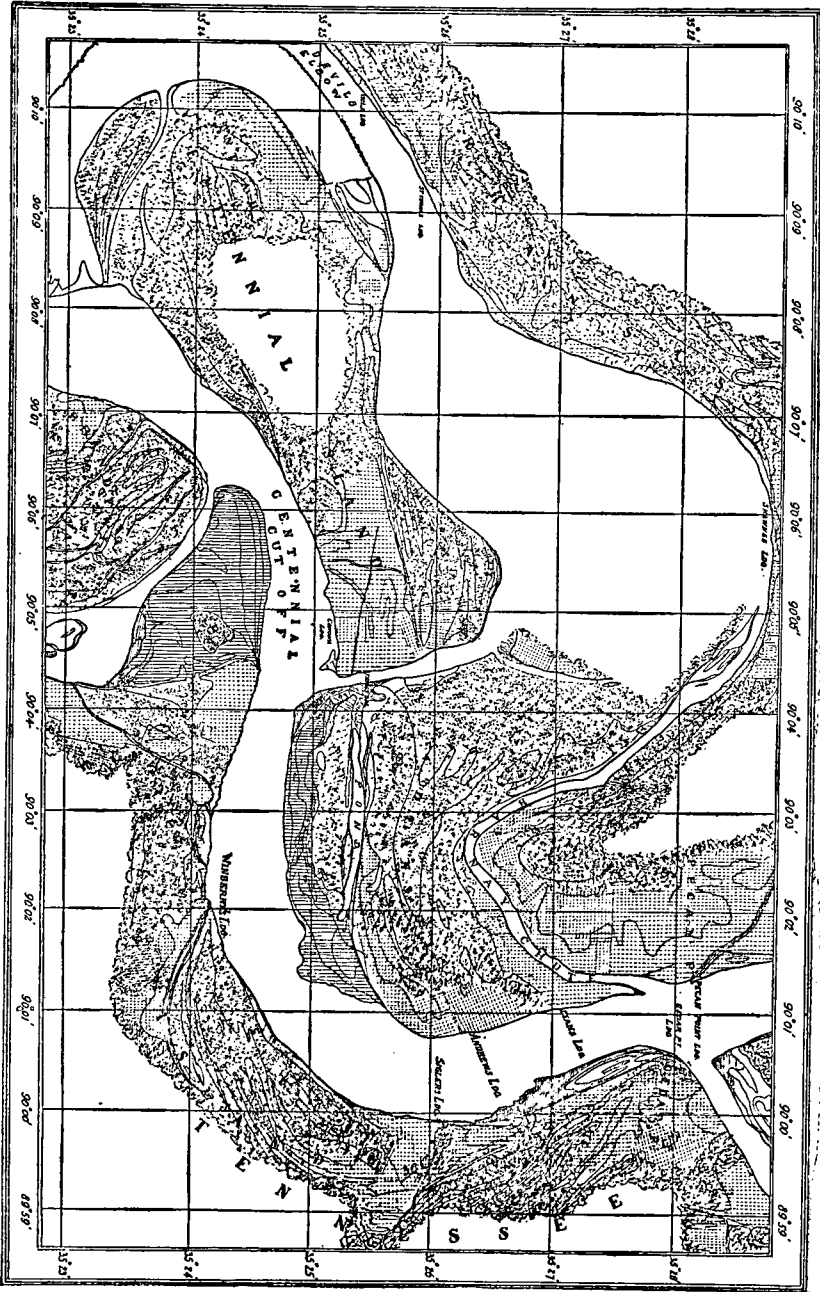

shores; second, from the calls and plots of Tennessee surveys and grants of land on the Tennessee side of the then channel of the river. The map, in reduced form, is set out herewith (see Humphrey's map, below).

Humphrey's Map.

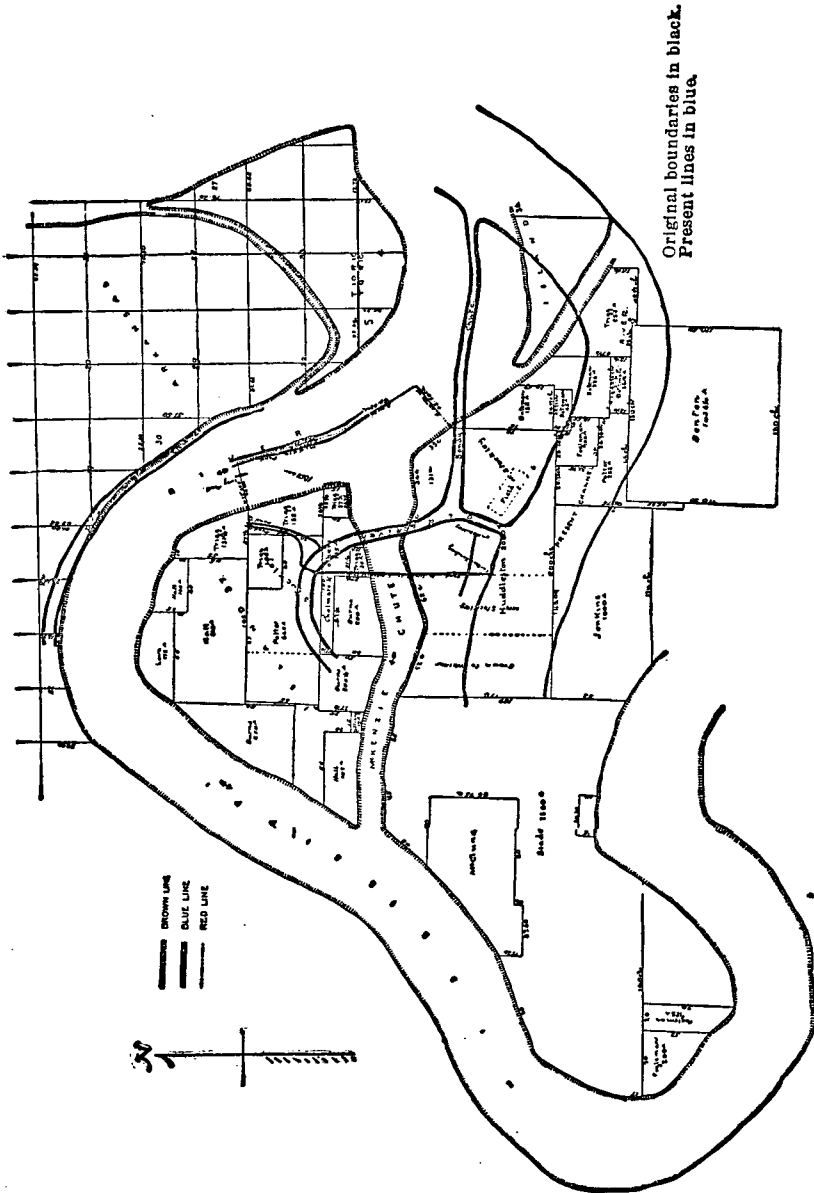

On this map the old banks of the river are represented by black shaded lines, as are also the collateral channels or chutes called "McKenzie's Chute" and "Dean's Chute." The channel now occupied by the river is shown by black lines shaded with blue. The land in dispute is that shown between red lines, though the western lines are not indicated. The Centennial Island tract, of 131 acres, is indicated by the lines marking off a tract of 131 acres on northwest corner of Centennial Island. This is claimed by the plaintiff to have been upland included within the lines of deeds under which he holds his Centennial Island lands, and that it was washed away by the river when its new channel was formed, and has been since restored by accretion. This Centennial Island tract is by the evidence indisputably shown to be included within the boundaries of a 2,000-acre grant to Simon Huddleston. As we shall have occasion to refer to the lines of that grant more than once, we here set them out: "Beginning at a willow marked S. S. Stephen Slade's northeast corner, on the bank of the Mississippi river; thence south with his line one hundred and fourteen chains to a mulberry marked S. H.; thence east two hundred chains to a mulberry marked S. H.; thence north seventy-eight chains to a white oak marked S. H., on the bank of the Mississippi river; thence down said river with its meanders north, 41 degrees west, thirty-five chains, south, 82 degrees west, thirty chains, north, seventy-one west, thirty-two chains, south, 70 degrees west, sixty-two chains; thence north, 72 degrees west, fifty-two chains, to the beginning." This grant bears date January 22, 1824. The eastern 1,500 acres of this tract were conveyed to John Trigg in 1837 by deed duly recorded, and this deed plainly includes the 131-acre tract now in dispute.

The plaintiff claims to derain title from this John Trigg, and for this purpose introduced the following conveyances:

(1) Will of John Trigg, 1865, giving the east 1,500 acres of Huddleston grant to his son W. W. Trigg.

(2) Quitclaim deed of certain persons claiming to be the widow and only surviving children and heirs of W. W. Trigg to plaintiff, Stockley. This deed is dated March, 1897.

(3) A decree of December 4, 1879, of the Shelby county, Tenn., chancery court, entitled as follows, "T. A. Nelson, Ex., v. M. L. Trigg, et al.," and reciting that "Sledge, McKay & Co., a mercantile partnership," had purchased two certain tracts of land in Tipton county, Tenn., one containing 33.75 acres and the other 305.75 acres, belonging to the estate of John Trigg, deceased, sold under the former decrees of this court, herein described as follows: "Portions of a certain tract of about 1,300 acres of land, situated in Tipton county, Tennessee, which has been surveyed by C. C. Burke, who reports that the Centennial Cut-Off has placed nearly 1,000 acres under the X of the Mississippi river, and which is in range 9, section 5, on said river; the said cut-off leaving 33.75 acres on the main land and 305.75 acres on the island: (a) The tract containing 33.75 acres begins at a stake on the bank of the Mississippi river, thence down said river with its meanders north, 75 degrees west, 16 chains, north, 76½ degrees west, 32 chains, south, 50½ degrees west, 3 chains and 8 links, south, 43 degrees west, 11 chains and 50 links; thence east 56 chains and 80 links to the point of beginning,—all open land," etc. "(b) The tract containing 305.75 acres begins at a stake on the bank of the Mississippi river, on Centennial Cut-Off, at the dividing line between C. A. Stockley's and John Trigg's land; thence north 97 chains and 14 links to a small cottonwood, marked T, on the bank of old river; thence up old river south, 71 degrees east, 11 chains, south, 50 degrees east, 13 chains, south, 40½ degrees east, 12 chains, south, 22 degrees east, 17 chains, south, 10 degrees east, 7 chains and 60 links, south, 9 degrees east, 9 chains, south, 18½ degrees east, 9 chains, south, 7 degrees east, 2 chains, south, 12 degrees east, 6 chains and 44 links, south, 30 degrees east, 6 chains, south, 7½ degrees west, 6 chains, and south, 28½ degrees east, 5 chains and 29 links, south, 3 degrees east, 5 chains and 30 links, to a point of entrance of Centennial Cut-Off; thence down said cut-off north, 86¾ degrees west, 8 chains, south, 83 degrees west, 8 chains, north, 85 degrees west, 9 chains, south, 84¾ degrees west, 11 chains and 60 links, south, 69 degrees west, 5 chains and 13 links, south, 69½ degrees west, 9 chains and 30 links, to the point of begin-

ning, of which there is 175 acres open land and in cultivation, with eight tenant houses, fencing moderately good," etc. The decree then proceeds to divest out of "the parties to this suit" all their right, title, claim, and interest, and vests the same "in the said partnership of Sledge, McKay & Co." No other part of this record is introduced, and there was no evidence as to who were parties to the suit, nor as to who constituted the partnership of Sledge, McKay & Co. These deeds were made in 1833.

(4) Deeds of persons describing themselves as the heirs and executors of Norfleet R. Sledge, Sr., and heirs of Wm. M. Sledge, conveying their interest in settlement of partnership affairs to A. N. McKay, described as surviving partner of the late firm of Sledge, McKay & Co.

(5) Deeds from persons describing themselves as executors and devisees under the will of A. N. McKay, and also as his heirs at law, to Thos. H. Allen, Jr. This is dated January 2, 1888.

(6) Thos. H. Allen, Jr., to plaintiff, W. H. Stockley, January 2, 1888.

The land claimed on Island 37 by the plaintiff is embraced in a single deed from one W. J. Cæsar to him, under date of April 18, 1898. The description is as follows:

"A certain tract, piece, or parcel of land lying, being, and situate on Island No. 37 in the Mississippi river, in said Tipton county, Tennessee, and more particularly described as follows, to wit: Beginning at the northeast corner of a 204½ acre tract in the name of R. H. Byrne, the same being also a corner of a 1,010-acre tract sold by R. I. Chester to L. Speck and John V. Wise; thence north with the line of the same to the northeast corner of same, a stake in the north boundary line of N. Potter's 640 acres, and in the south boundary line of 610 acres in the name of T. P. Hall; thence east in said line 350 poles, more or less, to the northwest corner of entry No. 8, for 152 acres in the name of John Trigg; thence south along west boundary line of said John Trigg's 152 acres to the bank of the Mississippi river; thence down said river as it meanders to the east or upper boundary line of said 204½-acre tract in the name of R. H. Byrne; thence north on said line to the place of beginning.

"It is hereby understood and agreed that at the present time the Mississippi river has changed its course, and does not now touch any of the above described lands, and that where said river is named as a boundary line it is understood to mean where said river once ran, which course of bed is now dry, and known as 'McKenzie's Chute'; and it is further understood and agreed that this conveyance carries with it all accretions now formed or added to said above-described lands. This deed is made and delivered in lieu of the deed heretofore executed by W. J. Cæsar to the grantee herein, covering the same premises, and which was lost or destroyed before its delivery."

The plaintiff's title is connected by several conveyances back to Robt. I. Chester, who in February, 1869, conveyed same to Mrs. Martha P. Smith, who was the owner and occupant at date of the origin of the Centennial Cut-Off, in 1876. The intermediate conveyances between Chester and the plaintiff all contain certain recitals and boundaries identical with those set out above. The deed from Chester omits the paragraph set out above, beginning, "It is hereby understood, etc.," and contains no reference whatever to the fact that the Mississippi river had gone dry, or to any accretions. There was evidence tending to show considerable encroachment of the river upon lands bounded on McKenzie's Chute and lying on Island 37. Just when this washing away occurred, and its extent, was not very clearly shown, though there were some evidences that considerable parts of the small grants shown by the Humphrey plat to lie south of the southern boundary of the 640-acre grant to Potter had been lost by erosion. The evidence also showed very conclusively that the two small grants to J. Trigg, one for 152 acres and one for 37 acres, and shown on the Humphrey plat, had been washed away prior to the cut-off of 1876, except a narrow strip of the 152-acre tract, along which a public county road ran. This remaining strip of the 152-acre tract is shown on the Humphrey map. The evidence shows that at that point the bank was high and firm, and that the high bank bent westward and passed the western line of the 152-acre tract, and is found then on the eastern end of the plaintiff's

land, a corner of which, shown fairly on the Humphrey map, had likewise been washed away prior to the cut-off of 1876. In this manner a part of the eastern boundary was on the river as it existed at time of the cut-off, although the eastern boundary called for the western line of the Trigg 152-acre tract, and not the river.

Accretions.

There was evidence tending to show that immediately after, and as a direct consequence of, the Centennial Cut-Off, land began to form all along the eastern border of Island 37, and along the northern and eastern corner of Centennial Island, and that within a few years the entire bed of the river was dry, except during very high water or because of the presence of ponds or sloughs in the deeper holes of the old bed. There was evidence, also, tending to show that, prior to the cut-off, land was forming rapidly on the western shore of Dean's Island, an island on the Arkansas side of the middle thread of the river, and that, as a result of the change in the course of the river at the cut-off of 1876, this formation went on with accelerated rapidity until the land resulting from such accretion united Dean's Island to the southern and northeastern shores of Island 37. There was also evidence tending to show that after the cut-off the river ceased entirely to flow either around Island 37 or through McKenzie's Chute, save in very high water, and that the water at once shallowed, and that shoals and islands appeared in the body of the stream, as well as along both shores, and that the bed of the river became rapidly dry, because the water had ceased to flow between the old banks. Certain it is that the whole bed of the river was substantially dry land within from three to ten years after the cut-off.

G. J. McSpadden, for plaintiff in error.

Caruthers Ewing, for defendant in error.

Before LURTON, DAY, and SEVERENS, Circuit Judges.

LURTON, Circuit Judge, having made the foregoing statement of the case, delivered the opinion of the court.

1. Jurisdiction of the court below: There was the requisite diversity of citizenship, and the jurisdiction of the circuit court was obvious, provided the locus in quo was within the boundaries of the state of Tennessee. When the territory now constituting the state of Tennessee was ceded by the state of North Carolina to the United States, the center of the main channel of the Mississippi river was the boundary separating North Carolina from the Spanish territory west of that river. *Moss v. Gibbs*, 10 Heisk. 283; treaty of Paris, Sept. 3, 1782; 8 Stat. 81; act admitting Arkansas, June 15, 1836 (5 Stat. 50); *Missouri v. Kentucky*, 11 Wall. 395, 401, 20 L. Ed. 116. The sudden change in the channel made in 1876, by which the river abandoned its long course around the bend known as the "Devil's Elbow," and cut a new, straight, and short channel across the neck of that bend, did not operate to change the boundary between Tennessee and Arkansas. The new channel was the result of a sudden and uncontrollable change in the direction of the main current of the stream. In cutting the new channel, some 2,000 acres of cultivated river bottom land was washed away in the course of about 60 hours. Within that time a new channel, some 20 to 40 feet deep, in ordinary water, was permanently established; being the channel now known as "Centennial Cut-Off." This channel shortened the distance around the bend some 15 miles. As another direct result, the old channel of the river, so long the boundary between the two states of Tennessee and Arkansas, was completely deserted by the river, and in a short

time became dry land. Thousands of acres of dry river bottom within the jurisdiction of Tennessee, as land lying on the east side of the main channel of the river, were by this sudden formation of this new channel placed upon the west side of the Mississippi river; and the inhabitants of nearly an entire civil district of Tipton county, one of the counties of Tennessee lying on the Mississippi river, found themselves living on the west, instead of the east, side of the great river. But this sudden change in the channel of the river did not affect the title to the lands thus transferred from one side of the river to the other, nor did it alter the boundary between the states. The middle of the main channel which the river abandoned was the boundary before the formation of the cut-off channel, and that line in the dry and abandoned bed of the river remains the line, unaffected by the new course of the river.

The doctrine is well settled that when lands border on navigable rivers, and the banks are changed by that gradual and imperceptible process known as "accretion," the boundaries of the riparian proprietor still remain the river, although as a consequence of such change in the shore line the area of his possession may change. A boundary on a river implies a boundary changing as the shore line changes by accretion or erosion, in the absence of definite intention to the contrary. *Posey v. James*, 7 Lea, 98; *Mayor, etc., of Inhabitants of New Orleans v. U. S.*, 10 Pet. 662, 717, 9 L. Ed. 573; *Jones v. Soulard*, 24 How. 41, 16 L. Ed. 604; *Banks v. Ogden*, 2 Wall. 57, 17 L. Ed. 818; *Saulet v. Shepherd*, 4 Wall. 502, 18 L. Ed. 442; *St. Clair Co. v. Lovington*, 23 Wall. 46, 23 L. Ed. 59; *Jefferies v. Land Co.*, 134 U. S. 178, 10 Sup. Ct. 518, 33 L. Ed. 872; *City of St. Louis v. Rutz*, 138 U. S. 226, 11 Sup. Ct. 337, 34 L. Ed. 941; *Nebraska v. Iowa*, 143 U. S. 359, 367, 12 Sup. Ct. 396, 36 L. Ed. 186. The rule applicable to private riparian titles is likewise applicable to the boundaries of nations situated upon opposite sides of a river. In *Nebraska v. Iowa*, cited above, the rule as stated by Vattel was adopted and applied in a disputed boundary between two states. After stating that every estate bounded by a river enjoys the right of alluvion, Vattel applies the same law to sovereign states, saying:

"As soon as it is established that a river separates two territories, whether it remains common to the inhabitants on each of its banks, or whether each shares half of it, or whether, in short, it belongs entirely to one of them. their rights with respect to the river are noways changed by the alluvion. If it happens, then, that by a natural effect of the current one of the two territories receives an increase, while the river gains by little and little on the opposite bank, the river remains the natural boundary of the two territories, and each preserves the same rights upon it notwithstanding it is gradually changing its bed; so that, for instance, if it be divided in the middle, between the persons on each bank, that middle, though it changes its place, will continue to be the line of separation between the two neighbors. The one loses, it is true, while the other gains, but nature alone produces this change. It destroys the land of the one, while it forms fresh land for the other. This can be no otherwise determined, since they have taken the river alone for their limits." *Vatt. Law Nat.* § 269.

But if the change in the channel of the stream be not gradual and imperceptible, but sudden and violent, so that a new channel is suddenly cut when there had been none before, and the old channel

deserted for the new, there is no change in the boundaries of states or nations bordering on the river. The boundary remains where it had been,—in the middle of the old abandoned main channel of the river. Vatt. Law Nat. § 270; *Nebraska v. Iowa*, 143 U. S. 359, 367, 12 Sup. Ct. 396, 36 L. Ed. 186; *Posey v. James*, 7 Lea, 98; *Moss v. Gibbs*, 10 Heisk. 283.

After fully reviewing the authorities, Mr. Justice Brewer, in *Nebraska v. Iowa*, cited above, says:

“The result of these authorities puts it beyond doubt that accretion on an ordinary river would leave the boundary between the two states the varying center of the channel, and that avulsion would establish a fixed boundary, to wit, the center of the abandoned channel.”

The evidence in this case made it clear that, whatever may be said in respect to the formation of new land within the banks of the old channel, the new channel called “Centennial Cut-Off” was an avulsion. This was the clear admission of both parties upon this question of fact before the court and jury below, and in consequence of which evidence was stopped; having no other purpose than to show the suddenness and violence of the change in the course of the river. As much as 2,000 acres was carried away in the course of about 60 hours, upon which stood farmhouses, stables, cotton gins, warehouses, etc.; and so rapid was the process of washing away the farms through which the river ran as to make it in some cases impossible to remove household effects rapidly enough to avoid the caving banks.

It is clear, whatever the interpretation placed upon the ambiguous judgment relied upon to show that the defendant withdrew his plea to the jurisdiction, that the lands in dispute are on the eastern side of the middle line of the channel of the old river, and therefore within the boundary of the state of Tennessee, although now west of the present channel of the Mississippi river.

2. As to the small parcel of 131 acres: The questions upon which the plaintiff’s right to recover this tract depends are not precisely the same as those in respect to the other and larger parcel, though many of the questions are common to both. There was evidence quite satisfactorily establishing the fact that this parcel, while owned by John Trigg, the second grantee in the line of title, was rapidly washed away by the sudden change of the course of the river in 1876, and that it has since been restored by accretion or some other process by which the submerged land has again emerged above the water. The plaintiff claims that this parcel, as plotted on the Humphrey map, was included within the grant of 1824 to Simon Huddleston, and in the deed of Huddleston to John Trigg of the 1,500 acres, forming the eastern end of the Huddleston grant. Speaking of this 131-acre tract, the court below said:

“Wholly on the bank as that was, and wholly above the low-water mark as it was in its original form, the plaintiff would be entitled to recover that 131 acres down to the low-water mark of 1876, when it was hid away by the flood of the cut-off of that year, if he had not failed to show title by deraignment,” etc.

Plaintiff did deraign title down to John Trigg, who was in possession of the premises at the time of the flood of 1876. His trouble

is to show how he has acquired the John Trigg title. A paper purporting to be a copy of the will of John Trigg, giving the 1,500 acres of the Huddleston grant owned by him to his son W. W. Trigg, was put in evidence. This operated to put title in W. W. Trigg, if of any effect whatever. How did the title get out of W. W. Trigg? The plaintiff undertook to show this by two lines of proof: First. He put in evidence a deed dated March, 1897, purporting to be made by certain persons describing themselves as being "all the heirs of W. W. Trigg, deceased"; one of the grantors describing herself as his widow, while the others describe themselves as his "only surviving children." This deed describes the property conveyed by the same description as that of the deed from Huddleston to Trigg. Second. He put in evidence a certified copy of a decree purporting to have been made by the chancery court for Shelby county, Tenn., entitled in a cause styled "T. A. Nelson, Ex., v. M. L. Trigg, et al.," divesting the title to certain portions remaining above water after the flood of 1876 of the Trigg 1,500-acre tract of land out of the parties to that suit, and vesting it in a partnership styled Sledge, McKay & Co. The boundaries of the tracts of land thus divested and vested have been heretofore set out. This decree was made December 4, 1879. The next link is a deed conveying the right and title of the grantors as heirs and executors of Norfleet R. Sledge, and as heirs of W. M. Sledge, in the land described in said decree, "in settlement of the partnership affairs of Sledge, McKay & Co.," to A. N. McKay, as the "surviving member of that firm." This deed purports to have been made in 1883, and describes the land as bounded by the chancery decree before mentioned. This is followed by a conveyance made in 1888 to Thos. H. Allen, Jr., by certain persons who describe themselves as executors, devisees, and heirs at law of A. N. McKay. Thos. H. Allen and wife in the same year conveyed to the plaintiff. The last two deeds described the land by metes and bounds, identical with those of the decree of 1879, and for the first time refer to accretions by adding to the description the words "and all accretions thereto." There are a number of difficulties in the title as thus made out. If the will of John Trigg operated to vest the title in W. W. Trigg, which we may assume, it devolved upon the plaintiff to deraign title from W. W. Trigg. This he claims to have done by the production of a deed from persons who describe themselves as the heirs of W. W. Trigg. There was no evidence of either the death of W. W. Trigg, or that the persons claiming to be his surviving children and heirs were in fact his children or heirs. The deed is practically a quitclaim, as it warrants only against persons claiming under the grantors. Being made in March, 1897, it is such a recent instrument as to carry with it no presumption in favor of the authenticity of the recitals as to heirship. That recitals in an ancient deed may be evidence as against persons who are not parties to the deed, and who do not claim under it, may be regarded as well settled. *Carver v. Jackson*, 4 Pet. 1, 7 L. Ed. 761; *Crane v. Morris' Lessee*, 6 Pet. 598, 8 L. Ed. 514; *Deery v. Gray*, 5 Wall. 795, 18 L. Ed. 653; *Fulkerson v. Holmes*, 117 U. S. 389, 6 Sup. Ct. 780, 29 L. Ed. 915; *Hodge v. Palms*, 68 Fed. 61, 15 C.

C. A. 220. The fact necessary to be established in order to give effect to this deed is that the persons making it were in fact the children and heirs of W. W. Trigg. The fact was one of pedigree, and this is a fact which may, upon grounds of necessity, be established by hearsay evidence, contrary to the general rule excluding evidence of that character. Now, the makers of this deed recite therein that W. W. Trigg is dead, and that they were his only children and heirs. Undoubtedly they were competent to prove these facts. But the plaintiff, instead of introducing them or other persons acquainted with the family, and proving their relation and the death of W. W. Trigg intestate, insists that the self-serving declaration of the grantors constitute evidence per se sufficient to make at least a prima facie case to go to the jury. We are not aware of any rule which attaches evidential value to recitals of this character in deeds not ancient, unless supported by circumstances tending to establish their authenticity. In *Carver v. Astor*, 4 Pet. 1, 83, 7 L. Ed. 761, Justice Story, after speaking of the value of a recital in deeds between the parties or their privies as estoppels, said of such a recital:

"It does not bind persons claiming by an adverse title, or persons claiming from the parties by a title anterior to the date of the reciting deed. Such is the general rule. But there are cases in which such a recital may be used as evidence against strangers. If, for instance, there be the recital of a lease in a deed of release, and in a suit against a stranger the title under the release comes in question, this recital of a lease is not per se evidence of the existence of the lease. But if the existence and loss of the lease be established by other evidence, there the recital is admissible as secondary proof, in the absence of more perfect evidence, to establish the contents of the lease; and if the transaction be an ancient one, and the possession has been long held under such release, and is not otherwise to be accounted for, there the recital will of itself, under such circumstances, materially fortify the presumption, from lapse of time and length of possession, of the original existence of the lease. Leases, like other deeds and grants, may be presumed from long possession, which cannot otherwise be explained; and under such circumstances a recital of the fact of such a lease in an old deed is certainly far stronger presumptive proof in favor of such possession under title than the naked presumption arising from a mere unexplained possession."

The rationale of the subject is that unless the recitals, in connection with other circumstances, are such as to raise a natural presumption of the truth of the facts recited, they are not evidence per se. The more ancient the deed, the less the necessity for circumstances in support. *Jackson v. Cooley*, 8 Johns. 128, is supposed to justify the admission of very recent recitals as evidence per se. But in that case there was evidence tending to support the truth of the recitals of heirship contained in the deed, and these circumstances were held strong enough, with the recitals, to make a prima facie case for the plaintiff. The rule seems to clearly be that recitals in a deed of recent origin that the makers are the heirs of a former owner, without circumstances in support, are not evidence against a stranger. *Jones v. Sherman*, 56 Miss. 560; *Costello v. Burke*, 63 Iowa, 361, 19 N. W. 247; *Potter v. Washburn*, 13 Vt. 558, 37 Am. Dec. 615; *Watson v. Gregg*, 10 Watts, 289, 36 Am. Dec. 176; *Mining Co. v. Irby*, 40 Ga. 479.

We do not find that the Tennessee supreme court has ever decided the question here presented. The cases cited from that state are for the most part cases in which the effect of recitals as estoppels between parties and privies, or recitals against interest, or recitals by officials in statutory deeds, were involved. There is nothing in any of the cases in conflict with the rule we have stated, and the reasoning in *Wilcox v. Blackwell*, 99 Tenn. 352, 41 S. W. 1061, and *Henderson v. Galloway*, 8 Humph. 692, is in line with the authorities we have cited.

In the case at bar there was no evidence that W. W. Trigg was dead, and none that the grantors in this deed were his children. There was in fact no evidence that these grantors had ever been in possession of any part of the premises conveyed. The deed itself was a quitclaim,—a circumstance not tending to support the claim of title and heirship. There was therefore a chasm in the chain of title through W. W. Trigg. But plaintiff did no better in his effort to deraign title from John Trigg through the judicial sale under decree of the Shelby county chancery court. No part of the record was introduced, except the final decree vesting and divesting title. The decree undertakes to divest title out of "the parties" to the cause, but does not recite who were parties. How are we to know that the heirs and devisees of John Trigg were parties? There is not even a recital that they were, and there is no presumption that they were, arising under the vague and indefinite recitals of the decree put in evidence by the plaintiff. There is no reason in such a case for indulging presumptions in favor of the jurisdiction of the court or the regularity of the proceedings, for there are no recitals in the decree from which we can even guess who were the parties over whom the court claimed to have jurisdiction.

We need go no further, for, if the subsequent links were made out, these chasms were fatal to the effort to deraign title from John Trigg. The plaintiff has failed to show that he has acquired the title of John Trigg, which appears to be the only legal title to either the lands on the bank of the river, or the new-made land included in the 131-acre parcel once submerged, but now restored.

Possessory title: But it has been very earnestly insisted that, if the plaintiff in error has failed to deraign title from John Trigg, he has nevertheless had such possession of the premises in dispute as to entitle him to recover in this action; and he has assigned it as error that the court did not instruct the jury that plaintiff had had such a continuous adverse possession under his deed from Thos. J. Allen, Jr., as vested him with an indefeasible fee-simple title in the lands therein conveyed, including the accretions thereby conveyed.

He has also assigned as error that the court did not submit to the jury, under proper instruction, the question as to whether plaintiff had shown an actual adverse possession for a period of seven years of any part of the land described in the conveyance of Allen to him. We have already called attention to the fact that the plaintiff Stockley's deed from Thos. H. Allen, Jr., conveys two distinct parcels. One is described as a tract of 33 acres and a fraction, and the other as a tract containing, by survey, 305 acres and a fraction. These

tracts are not connected, and the smaller one, with its accretions, is not here involved in any way. The parcel of 131 acres, which is claimed as an accretion, is not included within the specific boundaries described, but is conveyed by Allen, if at all, by operation of the added words, "and all accretions thereto." This 131-acre parcel is not an accretion to the 305-acre tract conveyed by Allen to Stockley, inasmuch as it is but a restoration of a part of the 1,500 acres conveyed by Huddleston to John Trigg, which was washed away as a first effect of the Centennial Cut-Off. But if we regard the conveyance as operating to convey this tract of new-formed land under the description of "all accretions thereto," we are then to inquire whether there was any such conclusive evidence of a continuous adverse possession for the full term of seven years by the plaintiff and those under whom he claims as would justify the court in withholding the question of title by possession from the jury, or, in the alternative, such a conflict of evidence tending to show such a continuous possession as would require the submission of the question to the jury.

There was evidence tending to show that plaintiff was in the actual possession of some part of the tract of 305 acres, and some evidence that he is also in the actual possession of some part of the accretion south of the 131-acre parcel, and south of what is called "Sandy Chute" on the Humphrey map, which accretion is not here involved. There is no evidence that he has now or ever had any actual possession of any part of the 131-acre accretion, other than that constructive possession which results from his possession of other parts of the land included in the Allen deed. We shall assume for the purposes of this case that the plaintiff's possession of the 305-acre parcel was a constructive possession of the 131-acre parcel although the two tracts may be claimed by different titles.

The contention upon this state of facts is that we must presume, and that it would have been the duty of the jury to presume if the case had been submitted to the jury, that this actual possession which is shown to have existed when the defendant entered began at the date of the deed from Allen, which was in January, 1888, and that thus the plaintiff has, through this presumption, shown an actual adverse possession for more than seven years under the deed of Allen, which at least was color of title under the Tennessee statute of limitations, and that by operation of such adverse possession he had at the commencement of this suit, in 1901, an indefeasible fee in all the lands so held by and under an instrument so purporting to convey the fee. Mill. & V. Code Tenn. § 3459; *Blantin v. Whitaker*, 11 Humph. 313; *Belote v. White*, 2 Head, 705, 712; *Bleidorn v. Mining Co.*, 89 Tenn. 167, 15 S. W. 737. There is no legal presumption that the plaintiff's actual possession began at the date of his deed from Allen, and there is no evidence from which the jury could reasonably and legally infer that his actual possession began then, or at any other date far enough back to constitute an adverse actual possession for more than seven years before the defendant's entry. To sustain his claim that the law raises a presumption that the plaintiff took actual possession of the land conveyed to him by the deed of Allen,

He cites *Lafferty v. Whitesides' Lessee*, 1 Swan, 123-128, and *Fowler v. Nixon*, 7 Heisk. 719, 727. These cases fall far short of sustaining any such contention. A deed or lease may constitute part of the evidence of possession, as showing its extent as well as characterizing it, but there is no authority for the contention that an actual adverse possession such as will start the statute of limitations is presumed from the mere fact that the plaintiff at a particular date took a deed, grant, or lease to the land in question. A title by seven years' adverse possession under a deed purporting to convey the fee requires an actual adverse occupation for the entire period of seven years, and no such evidence of a continuous adverse possession for that period by either the plaintiff or those under whom he claims was shown as to justify or require the submission of the case to the jury on that question.

But the plaintiff insists that, inasmuch as the plaintiff has shown a possession under color of title, which constructively extended to the 131-acre parcel as included within the Allen deed, and inasmuch as the defendant exhibited no paper title whatever, he is entitled to recover, as against the defendant, even though he has not shown a perfect legal title, by deraignment or otherwise. The defendant claims the premises in dispute as accessions or accretions to Dean's Island, upon which he appears to be a riparian proprietor. The land being new-made land, lying between occupants of opposite banks of the old channel of the river, each seems to have advanced claims based upon the law of accretion. True, the defendant has not shown a legal title to the old Arkansas bank. But he has taken actual possession of the res, and thus forced the plaintiff to all the hazards of an action of ejectment. The plaintiff has not chosen to resort to the Tennessee statutory action of unlawful entry. That is an action which tries only the immediate right of possession, and lies whenever there has been actual trespass, resulting in a tortious dispossession. On the contrary he has brought a straight action of ejectment, which in Tennessee is something more than a mere possessory action, inasmuch as the judgment, contrary to common law, is conclusive upon the parties, saving to persons under disability another action within three years after the removal of the disability. Shannon's Code Tenn. §§ 5000, 5001. Whatever may be the right of a plaintiff in other jurisdictions to recover in ejectment upon proof of mere possession at the time of the defendant's entry, in Tennessee the rule is well settled that the plaintiff cannot recover in ejectment unless he shows a perfect legal title, either by deraignment from the state, or by evidence of actual occupation under deeds purporting to convey the title for the full term of seven years. *Polk v. Henderson*, 9 Yerg. 312; *Kimbrough v. Benton*, 3 Humph. 129; *Campbell v. Campbell*, 3 Head, 325; *Walker v. Fox*, 85 Tenn. 154, 2 S. W. 98; *Evans v. Land Co.*, 92 Tenn. 355, 21 S. W. 670; *Hubbard v. Godfrey*, 100 Tenn. 150, 156, 161, 47 S. W. 81; *Stinson's Lessee v. Russell*, 2 Tenn. 40.

The precise question here involved received a full and elaborate reconsideration by Associate Justice McAlister in *Hubbard v. Godfrey* cited above. A judgment of the chancery court of appeals holding that the complainants might recover, although they had failed to show

a complete legal title or seven years' adverse possession, because the defendant had shown no title in himself and was a trespasser, was reversed, and the rule restated and fortified by a consideration of a long line of Tennessee decisions, constituting a well-settled part of the land law of the state. There was in the suit now under examination no evidence of such long and continuous possession under deeds purporting to convey the disputed premises by the plaintiff and those under whom he claims as to justify the submission of the case to the jury upon the question of a title by adverse possession. A possession for less than seven years, continuous and adverse, would not confer a title upon which ejectment may be maintained. The question is plainly one of local law, and we are constrained to follow the Tennessee rule in respect to the title necessary to maintain ejectment. The case of *Sabariago v. Maverick*, 124 U. S. 261, 296, et seq., 8 Sup. Ct. 461, 31 L. Ed. 430, is therefore not controlling.

The Plaintiff's Title to Lands on Island 37.

3. Before the plaintiff can recover the new-formed land on the margin of the solid land composing Island 37, he must be able to establish his ownership of the bank against which the accretion has formed. Until he does this, he has no shadow of claim as a riparian proprietor. The right to accretion depends upon the contiguity of the claimant's estate to the river. *Bates v. Railroad Co.*, 1 Black, 204, 17 L. Ed. 158; *Saulet v. Shepherd*, 4 Wall. 502, 18 L. Ed. 442; *Association v. Shriver*, 64 N. J. Law, 550, 46 Atl. 690, 51 L. R. A. 425. Accretion is an addition to riparian land made by the water to which the land is contiguous. *Posey v. James*, 7 Lea, 98; *St. Clair Co. v. Lovington*, 23 Wall. 46, 23 L. Ed. 59. In Tennessee it is well settled that a riparian proprietor of land upon a navigable stream owns only to ordinary low water mark. If the stream be nonnavigable, and his title call for the stream as a boundary, his title extends to the center of the stream. The title to the lands constituting the bed of a navigable stream, in the legal sense, is in the state, which it holds for the benefit of the public. *Holbert v. Edens*, 5 Lea, 204, 208, 40 Am. Rep. 26; *Elder v. Burrus*, 6 Humph. 358; *Martin v. Nance*, 3 Head, 649; *Goodwin v. Thompson*, 15 Lea, 209, 54 Am. Rep. 410. Conceding for the purposes of this case that the plaintiff has shown a title from the state or by adverse possession to the lands conveyed by the deed of April 18, 1898, from W. J. Cæsar to him, it by no means follows that he has shown either himself or those under whom he claims to have been riparian proprietors. Plaintiff's chain of title goes back to Robt. I. Chester, who in 1869 conveyed the lands now in question to Mrs. Martha P. Smith. While Chester's southern boundary was that branch of the Mississippi river called "McKenzie's Chute," yet his eastern line was the western line of a tract of 152 acres granted to John Trigg, and this Trigg tract lay between Chester's eastern line and the bank of the main channel of the Mississippi river. Mrs. Smith, Chester's vendee, was the owner when the Centennial Cut-Off occurred, and in 1889 we find her conveying the same land conveyed to her by Robt. I. Chester to a grantee in the plain-

tiff's chain of title, in which she conveys the land by the identical calls of the Chester deed, but adding these significant words:

"It is hereby understood and agreed that at the present time the Mississippi river has changed its course and does not now touch any of the above-described lands, and that where said river is named as a boundary line it is understood to mean where said river once ran, which course or bed is now dry and known as 'McKenzie's Chute'; and it is further understood and agreed that this conveyance carries with it all accretions now formed or added to said above-described lands."

The metes and bounds of Chester's deed and of all the intermediate conveyances are identical with those in Cæsar's deed to the plaintiff, already set out in the statement of the case. There was evidence tending to show that prior to the great flood of 1876 the greater part of this John Trigg tract of 152 acres had been washed away. When this occurred does not appear in any such conclusive way as to justify a refusal to let the question go to the jury, if a matter of any importance to the solution of the case. So there was like evidence as to the washing away of another small tract of 37 acres granted to John Trigg, lying south of Trigg's 152-acre grant, and east of the southern part of the tract conveyed by Chester to Mrs. Smith. Both these Trigg tracts have been platted upon the Humphrey map. The evidence tended to show, also, that McKenzie's Chute had encroached greatly upon the lands bordering upon its northern bank prior to 1876. By the partial washing away of the Trigg 152-acre tract, the southeastern corner of Mrs. Martha P. Smith's tract was partially washed away at some time prior to 1876,—date not shown. The plaintiff has in no way deraigned title from John Trigg to either of his small grants lying between the lands granted to his predecessors in title and the main branch of the river east of his eastern line. From all that appears, the title to these parcels which interpose between him and the old bank of the river as it existed when the Trigg grants were issued is outstanding in Trigg's heirs.

The deeds under which plaintiff claims call for the western line of the John Trigg 152-acre grant as plaintiff's eastern line. If the land lying east of Trigg's western line is to be regarded as included within the boundaries of the deed under which plaintiff holds, it is because it is included by the added words of description "This conveyance carries with it all accretions now formed or added to said above described lands." It is plain that these Trigg lands are not accretions to the lands described by metes and bounds, but restorations of the submerged John Trigg lands. But if we regard these words as mere words of description, and operative as a conveyance of the two Trigg parcels, it will, at most, make the deed mere color of title; for neither Cæsar, nor any of his predecessors in title, had acquired the John Trigg title. Nor is there any evidence of any actual possession of any part of the lands included within either of the two grants to John Trigg lying east of the land conveyed by Chester to Mrs. Smith. Possession wholly within the limits of the grant to Potter, or the deed of Chester to Mrs. Smith, would not be a possession operating to set the statute of limitations in motion as against the heirs or assigns of John Trigg, as owner of the 152-

acre and 37-acre parcels. To defeat the outstanding Trigg title, the plaintiff would have to show an adverse possession for the full term of seven years within the boundaries of both these grants. Possession of some part of the John Trigg grant is necessary to oust Trigg or his heirs or assigns, and, until an actual possession of some part of those small grants is shown, there is not shown any such adverse possession as would toll the Trigg title. *Smith v. McCall's Heirs*, 2 *Humph.* 163; *Stewart v. Harris*, 9 *Humph.* 715; *Tilghman v. Baird*, 2 *Sneed*, 196; *Boles v. Smith*, 1 *Tenn. Cas.* 149; *Mining Co. v. Heck*, 15 *Lea*, 497. The law gives the constructive possession to the legal title, and this constructive possession was not disturbed by a possession not within the boundaries of the grants to Trigg, although within the boundaries of a conflicting title which included the Trigg lands.

As a consequence of the changed course of the river in 1876, these submerged Trigg lands have been restored, through accretion or some other process, and are now dry land. It cannot be pretended that, because the surface of these two bodies of Trigg land was washed off, Trigg lost his title to the land so submerged, beyond recovery. The law is otherwise. Land lost by erosion or submergence is regained to the original owner of the fee when by reliction or accretion the water disappears and the land emerges.

It is said in Sir Matthew Hale's *De Jure Maris*, republished in 16 *Am. Rep.* :

"If a subject hath land adjoining the sea, and the violence of the sea swallow it up, but so that yet there be reasonable marks to continue the notice of it, or though the marks be defaced, yet, if it, by situation and extent of quantity and bounding on the firm land, the same can be known, though the sea leave this land again, or it be by art or industry, the subject does not so lose his property, and accordingly it was held by *Cooke and Foster*, M. 7 *Jac. C. B.*, though the inundation continue forty years." "But if it be freely left again by the reflex and recess of the sea, the owner may have his land as before, if he can make it out where and what it was, for he can not lose his propriety of the soil, though it for a time became part of the sea."

In *Mulry v. Norton*, 100 *N. Y.* 426, 3 *N. E.* 581, 53 *Am. Rep.* 206, a beach was washed away, and afterwards restored. The original owner was held to have regained his own. In that case the court said :

"It is not, however, every disappearance of land by erosion or submergence that destroys the title of the true owner, or enables another to acquire it, for the erosion must be accompanied by a transportation of the land beyond the owner's boundary to effect that result, or the submergence followed by such a lapse of time as will preclude the identity of the property from being established upon its reliction. Land lost by submergence may be regained by reliction, and its disappearance by erosion may be returned by accretion, upon which the ownership temporarily lost will be regained. When portions of the main land have been gradually encroached upon by the ocean, so that navigable channels have been extended thereover, the people, by virtue of their sovereignty over public highways, undoubtedly succeed to the control of such channels, and the ownership of the land under them, in case of its permanent acquisition by the sea. It is equally true, however, that when the water disappears from the land, either by its gradual retirement therefrom, or the elevation of the land by avulsion or accretion, or even the exclusion of the water by artificial means, its proprietorship returns to the original riparian owners. *Ang. Tide Waters*, 76, 77; *Houck, Riv.* p. 258. Neither does the lapse of time during which the submergence continues bar the right of such owner

to enter upon the land reclaimed, and assert his proprietorship. *Ang. Tide Waters*, 77-80, and cases cited."

In *City of St. Louis v. Rutz*, 138 U. S. 226, 246, 11 Sup. Ct. 337, 34 L. Ed. 941, a question of title to land formed by accretion to the bank of the Mississippi river arose. The plaintiff's land on the eastern shore had been washed away and restored. The court said:

"When land was formed again on the place where the plaintiff's land had been washed away, it became the property of the plaintiff, and, although the land thus newly formed, extended a short distance into the old bed of the river beyond the former shore line, such additional formation belonged to the plaintiff as a deposit on that part of the bed of the river which was owned by him in fee, and not to the state of Illinois or to any third party. Otherwise the plaintiff would be cut off, without his fault, from the river front and from his riparian rights."

The locality of the Trigg lands is not a matter of dispute. It is therefore a matter of no importance how long they have been submerged.

The heirs of John Trigg, or those to whom he conveyed same, are the beneficiaries of the restoration. Accretions east of the Trigg lands must be accretions to Trigg's title as a riparian proprietor, for he did not lose this benefit because for a time his own lands were submerged or wasted by erosion. The new land forming where his land had been inured to him by virtue of his title to the bed upon which the accretion was deposited. But if the accretion extended beyond his original shore line, it became an addition to his firm land by the slow and imperceptible movement of his boundary calling for the river.

4. Accretions to the 131-acre parcel: Accretions are apportionable among riparian proprietors according to the lateral lines of the firm land possessed by them. 3 Washb. Real Estate, 58; Gould, *Waters*, §§ 162-165; *Inhabitants of Deerfield v. Arms*, 17 Pick. 43, 28 Am. Dec. 276; *Mulry v. Norton*, 100 N. Y. 426, 3 N. E. 581, 53 Am. Rep. 206; *City of St. Louis v. Rutz*, 138 U. S. 226, 250, 11 Sup. Ct. 337, 34 L. Ed. 941. The plaintiff's right to accretions accruing to the 131-acre tract heretofore considered plainly depends upon establishment of his title to that parcel. This he has failed to do. Consequently he has failed to show any right to recover the accretions between its side lines extended.

5. The grant to plaintiff of 1901: This grant issued in 1901, and after this action had been brought. It was based upon an entry made in April, 1901, just before the action was begun. The grant relates back to the entry, and it is no objection that the grant did not issue prior to the suit, provided the action was after the entry. *Bleidorn v. Mining Co.*, 89 Tenn. 175, 15 S. W. 737; *Wood v. Elledge*, 11 Heisk. 612. The grant covers the land lying between the middle of the old channel of the river as the river ran before the Centennial Cut-Off and the bank of the river, not as it was in 1823 and 1824, but as plaintiff claims the bank to have been in 1876, just prior to that cut-off, and for an indefinite time prior thereto. It consequently includes the lands covered by the two older grants to John Trigg, containing, respectively, 152 and 37 acres. It does not include the 131-acre tract on Centennial Island, but bounds on that parcel. The

claim of plaintiff now is that if he has not the title to the new-made land described in his declaration, as a riparian proprietor, the title was in the state of Tennessee, and has been granted regularly and lawfully to him. Under the well-settled law of Tennessee, the soil below low-water mark of the navigable rivers of that state, as well as the use of the stream for purposes of navigation, belongs to the public, and the title is vested in the state for the use of the public. *Goodwin v. Thompson*, 15 Lea, 209, 54 Am. Rep. 410; *Elder v. Burrus*, 6 Humph. 358; *Martin v. Nance*, 3 Head, 649; *Stuart v. Clark's Lessee*, 2 Swan, 10, 58 Am. Dec. 49; *Posey v. James*, 7 Lea, 98. Under this rule of property, applicable in this case, the title of John Trigg extended only to low-water mark, and the title to the submerged land under the water and below low-water mark remained in the state for the use of the public. The land previously granted to Trigg, having been regained by accretion or otherwise,—having again become dry land,—was land regained, and was not subject to grant, as the state had parted with its title. *Curle v. Barrel*, 2 Sneed, 66. Plaintiff's grant is therefore void as to the land previously granted to John Trigg on the bank of Island 37, and can by no reasonable suggestion be valid for any land except that which lays between low-water mark of 1824 and the middle of the old channel of the river. This strip between the two lines mentioned was, prior to the flood of 1876, submerged land, and constituted the bed of the main channel of the Mississippi river. Although the titles of owners of land bounded by the Mississippi river extended only to low-water mark, under the well-settled law of Tennessee, yet, as we have already seen, low-water mark is an indeterminate and movable line; and if, by imperceptible additions made by the river to the shore, the area of firm land is insensibly extended, such additions are nevertheless included within the boundary of the grant or deed calling for the river as one of its boundaries. *City of New Orleans v. U. S.*, 6 Pet. 662, 717, 9 L. Ed. 573; *Jefferies v. Land Co.*, 134 U. S. 178, 188, 10 Sup. Ct. 518, 33 L. Ed. 872; *Nebraska v. Iowa*, 143 U. S. 359, 361, 12 Sup. Ct. 396, 36 L. Ed. 186.

In *Jefferies v. Land Co.*, cited above, the rule was thus stated:

"Where a water line is the boundary of a given lot, that line, no matter how it shifts, remains the boundary; and a deed describing the lot by number or name conveys the land up to such shifting water line, exactly as it does up to the fixed side lines; so that, as long as the doctrine of accretion applies, the water line, no matter how much it may shift, if named as the boundary, continues to be the boundary, and a deed of the lot carries all the land up to the water line."

This is also the law in Tennessee, and was applied in respect to accretions annexed to land bounded by low-water mark on the Mississippi river. *Posey v. James*, 7 Lea, 98. The question as to whether the title of a riparian proprietor extends only to high-water or low-water mark, or to the center of the stream, is a question to be settled by the local law, as a rule of property. *Barney v. Keokuk*, 91 U. S. 324, 328, 24 L. Ed. 224; *City of St. Louis v. Rutz*, 138 U. S. 226, 242, 11 Sup. Ct. 337, 34 L. Ed. 941.

It must follow from these principles that if the plaintiff's contention that the lands included in his grant, and lying between low-

water mark and the center of the river as it ran prior to 1876, is an accretion made against the bank of the river on Island 37 and Centennial Island, such accretion would constitute, when formed, an addition to the riparian titles, against which it has been built up, and within the boundaries of the grants to John Trigg on Island 37 and the grant to Huddleston on what is now called "Centennial Island." If this is the case, the state had no title to grant, for, as in *Posey v. James*, already cited, the accretions constituted an addition to the earlier grants calling for the river as a boundary. But it is also a well-settled rule of law that, if a river should suddenly change its course and abandon its original channel, the boundary line of lands bordering on the stream, and extending only to low-water mark, remain as they were before the desertion of the original channel. *City of St. Louis v. Rutz*, 138 U. S. 226, 245, 11 Sup. Ct. 337, 34 L. Ed. 941; *Nebraska v. Iowa*, 143 U. S. 359, 12 Sup. Ct. 396, 36 L. Ed. 186.

In the case last cited, the court, after stating the effect of an insensible growth by accretion to be that the owner of the shore to which the gradual addition is made shall still hold the added soil by the same boundary, said:

"It is equally well settled that where a stream, which is a boundary, from any cause suddenly abandons its old and seeks a new bed, such change of channel works no change of boundary, and that the boundary remains as it was, in the center of the old channel, although no water may be flowing therein. This sudden and rapid change of channel is termed, in the law, avulsion. In *Gould, Waters*, § 159, it is said: 'But if the change is violent and visible, and arises from a known cause, such as a freshet, or a cut through which a new channel is formed, the original thread of the stream continues to mark the limits of the two estates.' *Murry v. Sermon*, 8 N. C. 56; *Hagan v. Campbell*, 8 Port. 9, 33 Am. Dec. 267; *Academy v. Dickinson*, 9 Cush. 544; *Ang. Water Courses*, §§ 57-59; *Warren v. Chambers*, 25 Ark. 120, 91 Am. Dec. 538, 4 Am. Rep. 23; 2 Bl. Comm. side page 262; *Gould, Waters*, §§ 158, 159."

If, then, the fact was that the bed of the old stream was suddenly deserted, so as to constitute a case of reliction, rather than the formation of land by the slow processes of accretion, the riparian owners would not profit, for the title to the land so suddenly become dry by the stream deserting its old bed would continue in the state, in such jurisdictions as hold that the title to the submerged beds of navigable streams is in the state in trust for the public. In the latter event the learned trial court expressed the opinion that, under the Tennessee law providing for the granting and entering of the vacant lands belonging to the state, this deserted river bed was not open for entry and grant, and that the grant of November 26, 1901, to the plaintiff by the state, was invalid. The law under which the grant in question issued is chapter 20 of the act of 1847 (*Whitney's Tennessee Land Laws*, 303). The question as to whether the law of the state providing for the granting of "vacant lands" applies to the bed of a great navigable river, suddenly exposed by a change in the course of the river, depends upon whether such new-made dry land resulting from recession is "vacant land," within the meaning and policy of the land law of the state. In *Goodwin v. Thompson*, 15 Lea, 209, 54 Am. Rep. 410, it was held that the title to the soil under the waters of streams

navigable in a legal sense could not be acquired by individuals under the general land laws of the state, and a grant which expressly covered the bed of the French Broad river was held void. The opinion of the court was by Associate Justice Cooper,—a very able and discriminating judge,—and is founded upon a consideration of the policy of the state. In conclusion, the learned judge said:

“We think that the public use of our navigable rivers imperatively requires that the soil under the water should be in the state in trust for the public, that the title to the soil under such streams was not intended to be secured by individuals under our general land laws, and that any person setting up a claim thereto must be able to show an express legislative grant.”

The case, in its general meaning, is in accord with *Morris v. U. S.*, 174 U. S. 196, 19 Sup. Ct. 649, 43 L. Ed. 946, and *State v. Pacific Guano Co.*, 26 S. C. 50.

But it is said that, even if the sale and disposition of the soil below low-water mark on the navigable rivers of the state was not contemplated by chapter 20 of the Tennessee act of 1847, if at the time the grant to plaintiff was issued the waters had so far withdrawn from the old bed of the river as to permit occupancy and cultivation they were thereby brought within the scope and meaning of the law providing for the sale of the ordinary vacant lands belonging to the state. To support this proposition, plaintiff's attorneys cite *Tatum v. Sawyer*, 9 N. C. 226; *Hatfield v. Grimstead*, 29 N. C. 139; and *Allegheny City v. Reed*, 24 Pa. 39.

Tatum v. Sawyer involved a grant to a salt marsh, made in 1819. The contention was that the grant was void because it was not land, within the meaning of the North Carolina act of 1717, providing for the granting of the vacant lands of the state. It was shown “that the whole marsh on which the plaintiff's grant lies has formed gradually since the year 1802, up to which time it was a sandy beach, always covered at flood tide and dry at ebb.” In the court below it was, among other things, insisted that the premises were not subject to the entry laws, “as it was not land when the act of 1717 regulating entries was enacted.” The trial judge held the grant valid. The supreme court affirmed the case, saying upon this point only this:

“Lands covered by navigable waters are not subject to entry under the entry law of 1777. It is the legitimate object of a particular description in a grant to designate with more certainty and precision what the parties suppose to be vague and ambiguous in the general one; and therefore, wherever the particular description restrains the general one to natural boundaries, upon those boundaries being shown, the general description is confined to them.”

In *Hatfield v. Grimstead* the grant covered a shallow salt marsh or shoal. “These shoals,” said the court, “were not fit for any purpose, save that of hunting grounds for wild fowls that resort there in large numbers to feed on the water grass and moss.” The court held that it was subject to entry at the common law, because there was no regular ebb and flow of the tide in Currituck Sound since the closing of the inlet, and that the provisions of the entry acts of the state directing how lands should be surveyed, or navigable waters which might have forbidden such an entry, were not in force at the date of the entry.

in question, and that "while those provisions were dormant the common law was alone in force."

Allegheny City v. Reed, cited above, turned alone upon the provisions of the Pennsylvania statutes describing the character of islands which were subject to entry; the court holding that the character of the island sought to be entered was to be ascertained at the time of the entry, and that, if the conditions prescribed then existed, the island was subject to entry. The question of whether subject to entry or not was by the statute made to turn upon whether the island had a soil subject to cultivation.

None of these cases deal with the case of a sudden and extraordinary recession of the waters of a navigable stream, exposing the bed of the river as a consequence of the adoption of a new channel, which is the case now under consideration. The well-settled law, as declared by the supreme court of the United States, is that the ownership of and dominion over lands covered by the navigable rivers and lakes of the United States within the limits of the several states belong to the several states within which they are found, and that if a state, having such title and dominion, see fit to dispose of the title to private persons, it may do so, subject only to the paramount interest of the public in such waters, and of congress to control their navigation. *Illinois Cent. R. Co. v. Illinois*, 146 U. S. 387, 13 Sup. Ct. 110, 36 L. Ed. 1018; *Morris v. U. S.*, 174 U. S. 196, 236, 19 Sup. Ct. 649, 43 L. Ed. 946; *Scranton v. Wheeler*, 6 C. C. A. 585, 57 Fed. 803. Nevertheless it is now settled that, although congress has the power to grant lands below high-water mark of any navigable river within the limits of any territory of the United States, the policy of the United States has been not to do so, and that the general laws should not be construed as extending any grant below high-water mark, in the absence of an affirmative statute, and that grants by the United States of public lands within a territory, though bordering on a river or lake, convey, of their own force, no title or right below high-water mark. *Shively v. Bowlby*, 152 U. S. 1, 14 Sup. Ct. 548, 38 L. Ed. 331. In *Manns v. Land Co.*, 153 U. S. 273, 14 Sup. Ct. 820, 38 L. Ed. 714, it was held that land scrip issued by the United States, to be located on any unoccupied and unappropriated lands, could not be located on lands covered and uncovered by the ebb and flow of the tide. In the same case it was held that the words "public lands," in the general legislation touching the disposition of vacant lands, should not be construed as applicable to such tide-water lands.

Morris v. U. S., 174 U. S. 196, 19 Sup. Ct. 649, 43 L. Ed. 946, is a case much more clearly in point than any to which our attention has been called. The locus in quo there involved was a part of the raised lands known as the "Reclaimed Flats," lying along the bank of the Potomac river in front of the city of Washington. The land at the time of the cession of the District of Columbia to the United States was a part of the bed of the Potomac river. The title to the submerged lands constituting the bed of the river was, under the royal charter and laws of Maryland, in the state of Maryland at the date of the cession; and this title passed to the United States at the time of

cession, as well as the Maryland title to all other vacant domain of the state within the ceded district. The acts of the state of Maryland for securing titles to vacant lands were continued in force by a resolution of the congress passed in 1839, and the secretary of the treasury, through the general land office, was required to execute them by issuing warrants and receiving pay for same according to the law of Maryland, and to complete the sale of such vacant lands under the law of Maryland in force at date of cession by issuance of patents in usual form of such patents. In 1869 one Kidwell procured a patent under this resolution for a tract of 57 acres lying in the Potomac river, and known as "Kidwell's Meadows." The contention of the United States was that this patent issued without authority of law, and was null and void. This claim was mainly rested upon the proposition that the land covered by the patent was exempted from the operation of the resolution of 1839, because the land was at the time of cession and at date of said resolution subject to overflow by the tides. In reference to this the court held: First, that the resolution of congress should be construed as applying only to such vacant lands, "for securing title to which the laws of Maryland which were in force in 1801 had made provision," but which were inoperative after the cession for want of appropriate officers and authority within the District for their execution; second, that by the terms of description in the Maryland acts these laws were intended to apply to lands susceptible of some cultivation, and that they did not contemplate a disposition of any lands covered by tide water, the natural and primary use of which was public in its nature, for highways of navigation and commerce. It was claimed, however, that, the waters having receded from the meadows in question, the reasons for exemption from the operation of the resolution of congress had ceased. To this the court replied, saying:

"It cannot, we think, be successfully claimed that even if, in 1839, the lands embraced within the Kidwell patent were exempted from the jurisdiction of the land office, yet they were brought within that jurisdiction by the fact that the waters had so far receded in 1869 as to permit some sort of possession and occupancy. Not having been within the meaning of the resolution of 1839, they would not be brought within it by a subsequent change of physical condition, but a further declaration by congress of a desire to open them to private ownership would be necessary. Besides, the facts of the case show that congress is asserting title and dominion over these lands for public purposes. Whether congress should exercise its power over these reserved lands by dredging, and thus restoring navigation and fishery, or by reclaiming them from the waters for wharfing purposes, or to convert them into public parks, or by subjecting them to sale, could only be determined by congress, and not by the functionaries of the land office. If, then, there was an entire want of authority in the land office to grant these lands held for public purposes, a patent so inadvertently issued, under a mistaken notion of the law, would plainly be void, and afford no defense to those claiming under it as against the demands of the government."

The locus in quo presents circumstances of a character quite as unusual as any which appeared in the case of *Morris v. U. S.* The lands included in the grant were at the time of the enactment of the law under which the grant was issued plainly and clearly not within the terms of the law. They were not unoccupied "vacant lands," within the meaning of the Tennessee act, as determined by the highest court of that state. They have since become dry land, capable of

occupation by a most extraordinary natural phenomenon,—the sudden abandonment by a great river of its natural channel for a new and shorter one. The situation is one which could not have been reasonably contemplated by the lawmaker, when providing for the ordinary vacant lands belonging to the public domain. The lands in question were not at the date of the act of 1847 within the meaning and purview of the makers of the law, because it was the policy and purpose of the state to reserve for the public use the beds of such navigable rivers. Who shall say that, because by a sudden recession of the waters, the lands thus exposed are no longer to be reserved for public purposes? Non constat but that the river may be turned back, by congress or the state, into its old channel, or the old channel dredged so that it will continue to be a highway of commerce. Is the state to be prohibited from converting such a body of land into a highway or public park?

Not having been within the meaning of the Tennessee acts which provided for the disposition of the unoccupied and ungranted land of the state at the time these acts were passed, the locus in quo had not been brought within the terms of these acts by the subsequent extraordinary physical change which has occurred. The dry river bed is public property, held by the state for public purposes, but some further legislation by the state is necessary before such a property will become open to private ownership. There was no such state of evidence as would justify the court in instructing the jury that the premises included in the grant below low-water mark of 1824 was an addition by accretion to the lands granted prior thereto and bounded by the river, or that the change which had occurred had been so sudden as not to be regarded as an accretion. But in either case the grant was ineffectual to give title to the plaintiff. There was therefore no error in an instruction to find against the plaintiff.

Judgment is accordingly affirmed.

On Rehearing.

(February 3, 1903.)

The petition to rehear has been carefully considered, and must be denied. The questions raised by it chiefly concern the correctness of the result reached as regards that part of the land in controversy claimed as accretions formed against what was the eastern bank of Island No. 37. Plaintiff claimed said new-formed land under two distinct lines of title: First, as an accretion to the tract of land on Island 37 conveyed in 1869 by Robert I. Chester to Mrs. Martha P. Smith, and to plaintiff by sundry mesne conveyances, the last being from W. J. Caesar; second, under a grant from the state of Tennessee.

We did not support the instruction of the court below upon any theory that this new-made land was not formed by the slow and gradual process called "accretion," but upon the ground that, whether accretions or not, the plaintiff in error could not recover in an action of ejectment without showing either that he was a riparian proprietor against whose lands the locus in quo had formed or that he held a legal title derived from some other source. The conclusion we reached was

that the plaintiff had not shown title to such accretions by reason of riparian ownership, nor any title derived from any other source, and that the instruction to find for the defendant was therefore not erroneous. This conclusion was reached upon the construction of the title papers introduced by the plaintiff, including the Humphrey survey and plots of the old grants on Island 37, and upon the undisputed physical facts necessary to the interpretation of the title papers. Manifestly, the question of title, not turning upon conflicting evidence, was a question of law for the court below. If the plaintiff failed to show such a legal title as would support an action of ejectment, it was the duty of the court to instruct for the defendant; for it was a matter of no concern to the plaintiff whether the locus in quo was the property of the heirs of John Trigg, Mrs. Martha P. Smith, or of the defendant. If the plaintiff had failed to show title in himself, his case broke down, and that was an end of it. It was an inadvertence in our former opinion to say that the title to the two John Trigg grants was outstanding "in the heirs of John Trigg." It was not necessary to say more than that the title was not in the plaintiff, and that we did find as a result of the proper interpretation of the deeds under which the plaintiff holds his land on Island 37. In a later part of the same opinion we referred to the title to the Trigg grants as being in the heirs of John Trigg "or his assigns."

The original contention, vigorously supported by the briefs of plaintiff's counsel, was that the wasting away of the Trigg lands operated as a complete destruction of that title, and that plaintiff's land thereby became riparian, and entitled to all accretions thereafter formed, although made on the site of the submerged Trigg lands. It was further contended that, as the accretions here involved had been made long before Mrs. Smith conveyed her Chester land, thus become riparian, to S. M. Jarvis, through whom plaintiff claims, with a clause conveying all accretions to the land described, this accretion clause operated to pass the locus in quo, because it was an accretion to the land conveyed. This contention we did not accept. Upon the contrary, we held that the accretions in question were not accretions to the Chester land conveyed by Mrs. Smith, but accretions inuring to the benefit of the owners of the two Trigg grants. It is as unnecessary now as when we wrote our opinion to decide whether Mrs. Martha P. Smith had acquired the title to the two Trigg grants before she made her mortgage to S. M. Jarvis in 1889. If she did not convey the lands covered by those grants, it in no way assists the plaintiff.

The plaintiff's contention now is that if Mrs. Martha P. Smith in fact owned the two Trigg tracts when she made the mortgage to Jarvis, under whom the plaintiff remotely claims, that effect should be given to that fact in applying that clause of her deed which recites that it is "understood and agreed that this conveyance carries with it all accretions now formed or soddied to said above-described lands," and that we should hold that she intended to convey her Trigg lands and the accretions thereto under the description of "accretion now formed and soddied to said above-described lands." Now, the land described in her deed was a tract of land conveyed to her in 1869 by Robert I. Chester, and being for the most part the land shown on

the Humphrey map as the Potter 640-acre tract. Chester described his eastern boundary as the western line of the John Trigg 152-acre grant, also shown on the Humphrey map. The call of his deed was to run south with the western line of Trigg to the Tennessee river, thence with the meanders of the Tennessee river to the eastern line of the Byrne 204½-acre tract, and with that line to the beginning. The only material difference in the description of the land conveyed to Mrs. Smith by Chester in 1869 and that conveyed by her to Jarvis in 1889 is that, after describing the land as described in Chester's deed, she added a clause in these words:

"It is hereby understood and agreed that at the present time the Mississippi river has changed its course, and does not now touch any of the above-described lands, and that where said river is named as a boundary line it is understood to mean where said river once ran, which course or bed is now dry, and known as 'McKenzie's Chute'; and it is further understood and agreed that this conveyance carries with it all accretions now formed or soddod to said above-described lands."

Now, "the above-described lands" confessedly do not include by description these two Trigg tracts. Upon the contrary she necessarily excludes these Trigg lands by her specific call for a corner in the western line of the Trigg 152-acre tract, a corner standing on a part of that tract which had never been washed away, and by making the western line of that grant the eastern line of the land conveyed. Having thus deliberately excluded the locus in quo by this call for the western line of the Trigg 152-acre tract, it is now insisted that she subsequently included the same by the description of "lands now formed or soddod to the above-described lands." The improbability that she intended any such thing is further indicated by the fact that, when she made this deed to Jarvis in 1889, these Trigg lands had been for 10 years or more high and dry land, and were claimed by her under a distinct deed, made long after her deed from Chester, describing them by specific metes and bounds.

The only argument advanced now in support of the construction claimed for her accretion clause is that there is no other new-made land to which the term "accretion," used in her deed, can be applied, and that, in order to give some effect to that clause, we should construe it as operating to convey the locus in quo to Jarvis, although it did not answer the description of an accretion added to the lands specifically described and conveyed. But this is an unfounded assumption. If her deed to Jarvis be construed, as the brief for a rehearing contends, as bounding the land described and conveyed on the east and south by what is called the "high bank of 1876," meaning the river bank as it was at the flood of 1876, she will exclude the whole southeastern corner of the Potter 640-acre tract; for that high bank is shown to have bent westwardly from a point only 32 poles south of the northwest corner of the Trigg 152-acre tract. This interpretation would also exclude the land inside of the Potter grant which is occupied by the bed of what is called "old river," and shown on the Humphrey map, as well as lying south of that channel as defined and plotted by plaintiff's witness Humphrey. Now, all thus excluded was plainly included in Chester's deed to her, and, if Jarvis was to get all of the land which she got from Chester, he got the part restored by accre-

tion only as an accretion to that specifically described. That the bed of the so-called "old river" had filled up so as to be dry, tillable land, save in times of high water, is the claim and contention of plaintiff. If, therefore, we are right in saying that the accretion upon the site of the Trigg grants inured to the owner of those grants, the accretion made upon the washed-away parts of the land conveyed by Chester to Mrs. Smith inured to the benefit of her title, and passed as accretions to her grantee, being literally accretions to the lands described in her deed.

But, if the third call in Mrs. Smith's deed to Jarvis be extended to the old channel of McKenzie's Chute, as shown on the Humphrey map, in accordance with the explanation she makes in her deed as to what she meant by calling for McKenzie's Chute, the case is no better. That chute was one of the main channels of the Mississippi river, and is now dry land. Now, if accretions have formed against the old shore of Island 37 as a result of the cut-off of 1876, such accretions would follow the title of the shore against which they formed. In this event the made land which shall prove to be an accretion to that described by the deed, which calls to follow the meanders of the river to the eastern or upper line of the Byrne tract of 204½ acres, would pass under her accretion clause to Jarvis, her grantee. There is in no event any reason for stretching the meaning of her accretion clause, to cover lands otherwise plainly excluded, merely for the purpose of giving some effect to that clause. If it be said that in fact the new-made land in the bed of McKenzie's Chute is not an accretion to the shore of Island 37, but to the opposite bank, there would still be no greater reason for applying the accretion clause to the new-made land on her eastern boundary, than upon her southern, and the deed should be construed as applicable only to such accretions as were in law and fact accretions to the land described, if it should turn out that there was any such accretion. The case is not one where we can reform her deed. It must stand as she wrote it.

The other matters touched upon in the petition are mere rearguements of questions once argued and once decided.

COONROD v. KELLY et al.

(Circuit Court of Appeals, Third Circuit. December 5, 1902.)

No. 5.

1. EQUITY—SUFFICIENCY OF EVIDENCE TO SUPPORT BILL.

Where answer under oath was not waived, and the answers so made were responsive to the bill, and were supported by the testimony of the defendants, who were called as witnesses by complainant, the force of such testimony is not overthrown by the fact that it is improbable or open to suspicion under the peculiar facts and circumstances of the case, and the facts alleged in the bill can only be established by affirmative evidence, either direct or circumstantial.

2. MORTGAGES—FAILURE TO RECORD—EFFECT UNDER NEW JERSEY STATUTE.

Under Gen. St. N. J. p. 2106, § 22, which makes every mortgage void against a subsequent bona fide mortgagee for a valuable consideration without notice thereof, unless it is lodged for record at or prior to the time

of the lodging for record of the subsequent mortgage, a purchaser of a mortgage having priority of record is entitled to rely on the priority of lien which such record gives, and is not chargeable with notice from the record that a mortgage subsequently recorded was in fact prior in time because it bears a prior date, no presumption arising from the facts so appearing that it was actually delivered on the day of its date.

3. SAME—RIGHTS OF ASSIGNEE.

The assignee of a mortgage takes all the rights of his assignor, and if, in the hands of the assignor, it was entitled to priority over another mortgage under the statute because of its priority of record, and of the fact that it was taken by the assignor for a full consideration, and without notice that the other mortgage had in fact been previously executed, it has the same priority in the hands of the assignee, although he may have taken it with knowledge of the facts.

4. SAME—RIGHT OF SUBROGATION TO LIEN OF CANCELED MORTGAGE—INNOCENT ASSIGNEE OF INTERVENING MORTGAGE.

Complainant made a loan to an owner of property, taking a mortgage therefor. There was a prior mortgage on the property, which he paid off from the proceeds of the loan, but before doing so, and recording his mortgage, several days elapsed, during which a third mortgage had been given by the mortgagor and recorded, which, under the statute, gave it priority over complainant's. After the first mortgage had been canceled the third mortgage, which was then first of record, was sold to defendant, who bought in good faith and in reliance on the record. *Held*, that complainant was negligent in not examining the record before canceling the first mortgage, and that as against defendant he was not entitled to be subrogated to the lien of such mortgage.

Appeal from the Circuit Court of the United States for the District of New Jersey.

Joseph Colt, for appellant.

Joseph Cross, for appellee.

Before ACHESON, DALLAS, and GRAY, Circuit Judges.

GRAY, Circuit Judge. This is an appeal from a decree of the circuit court of the United States for the district of New Jersey (113 Fed. 378), in a suit in equity brought by the appellant, by bill filed against the above-named defendants.

The essential facts, as disclosed by the pleadings and testimony, are that, some time prior to May 1, 1899, George Booth, one of the defendants, who was doing business as agent of his wife, Ella Booth, another of defendants, became indebted to William H. Coonrod, the complainant, to the amount of about \$2,400. Ella Booth at that time owned the real estate described in the bill, situate in North Plainfield, Somerset county, N. J., which was subject to a mortgage for \$10,000, held by the Mutual Life Insurance Company of New York, on which, at the time of the transactions herein set forth, there was due \$5,000 of principal and \$102 of interest. On or about May 1, 1899, it was arranged between the Booths and Coonrod that a mortgage for \$10,000 on this property of Ella Booth should be given to Coonrod, and that Coonrod should pay off the amount due on the mortgage to the Mutual Life Insurance Company, cancel the debt of \$2,400 due to Coonrod from the Booths on book account, and advance them \$2,498

¶4. Subrogation to rights of mortgagee, see note to *Rachal v. Smith*, 42 C. C. A. 304.

in cash, the balance necessary to make up the \$10,000. A bond for the amount of \$10,000, in favor of Coonrod, and a mortgage to secure the same upon the property of Ella Booth, above mentioned, were executed, in the absence of Coonrod, by George and Ella Booth, on May 1, 1899, before a notary public. This bond and mortgage were afterwards, on the 3d of May, 1899, delivered to the said Coonrod, in the office of his attorneys, Colt & Howell, in Newark, N. J. At the time of the delivery, a search of the property mortgaged, certified by one Badgley, attorney or agent of the Booths, up to May 2, 1899, was exhibited to the appellant. This search showed that the property in question was clear of liens, except the stated mortgage to the Mutual Life Insurance Company for \$10,000, as to which it was noted that \$5,000 of the principal had been paid. It was also stated by the parties mortgagors at the time of the delivery to Coonrod, that the mortgage delivered would be a first lien on the property described in it, after the cancellation of the mortgage to the Mutual Life Insurance Company. The delivery of the bond and mortgage by Booth to Coonrod was made shortly after 11 o'clock a. m. on the 3d of May, 1899. About 2 o'clock, or between 1 and 2, of the same day, the Booths went to the office of Frederick J. Howlett, one of the defendants, and, pursuant to an arrangement previously made, executed and delivered to the said Howlett a mortgage for \$8,000, upon the same premises which were described in the Coonrod mortgage.

It is in testimony, and not disputed, that immediately after the delivery of the Coonrod mortgage, it was handed by Coonrod to Mr. Howell, his attorney, in order that it might be recorded, and that Mr. Howell, on the same day, May 3, 1899, mailed it to the clerk of Somerset county for that purpose. On the 5th of May, he received it back, with a letter dated May 4, 1899, stating that the mortgage was not sufficiently stamped, and that on that day, May 5th, Mr. Howell stamped the mortgage and remailed it to the clerk of Somerset county, with his check for two dollars and a half, the amount of recording fee. It was received and recorded by the clerk on May 6, 1899. The mortgage on the same property subsequently delivered to Howlett on the said 3d of May, was taken by Howlett personally, in the afternoon of that day, to the office of the clerk of Somerset county, and lodged for record as of that date.

On the day on which the transaction was closed, May 3, 1899, Mr. Howell testifies that as attorney for Coonrod, he deposited the draft for \$5,000 and a check for \$102 in a national bank of Newark, and drew Colt & Howell's check for \$5,102, to the order of the Mutual Life Insurance Company of New York, and having had the same certified, sent one of his clerks with it to New York, to pay off and take up the mortgage held by that company. This was done, and the bond and mortgage held by the Mutual Life Insurance Company was returned. The mortgage was then forwarded by Mr. Howell to the clerk of Somerset county for cancellation, and it appears by the clerk's certificate that the said mortgage of the Mutual Life Insurance Company was canceled of record on May 8, 1899.

Howlett held the \$8,000 mortgage until June 30, 1899, when he made an assignment thereof to the Dime Savings Institution of Plainfield,

N. J., one of the defendants. The bill charges, upon information and belief, that Howlett never paid or advanced to George Booth and Ella Booth, his wife, any moneys whatever on account of the \$8,000 mortgage made to him, and that the making, execution and delivery of said mortgage was a scheme devised by the Booths and Howlett to place upon the records an incumbrance in a secret manner, and for the purpose of defrauding either the complainant or such person as might subsequently become assignee of the said Howlett mortgage; that neither of them ever made any disclosure of the facts in relation to the making of the said \$8,000 mortgage, and that complainant discovered it by accident in the latter part of November, 1899. Complainants, therefore, insist that said mortgage never had any validity in the hands of the said Howlett, and was never a lien upon said premises, and that the Dime Savings Institution of Plainfield acquired no better security or lien than Howlett, and that, therefore, said mortgage is invalid in the hands of the said savings institution as against complainant's mortgage.

The bill also charges, upon information and belief, that the Dime Savings Institution of Plainfield had full knowledge and lawful notice that the mortgage made by the Booths to complainant was executed and delivered prior to the mortgage made by them to said Howlett, and that said savings institution had lawful notice that complainant's said mortgage was a first and paramount lien upon said lands. The bill further charges that, inasmuch as the moneys advanced by complainant to the said Booths, on the said \$10,000 mortgage, or a portion thereof, were used for the purpose of taking up and paying off the prior mortgage on said lands held by the Mutual Life Insurance Company of New York, complainant is and should be subrogated to the rights of the said Mutual Life Insurance Company under the said mortgage, and by virtue thereof has acquired in equity and now holds the same rights in said property, and the same lien thereon, as was held by the said Mutual Life Insurance Company at the time complainant took up and paid off said mortgage. And the bill further charges that, by virtue of the premises, complainant now holds a first and paramount lien upon the said property, by virtue of his own mortgage and of the mortgage held by the said Mutual Life Insurance Company.

The bill prays: (1) That an account may be taken, under the direction of the court, of the amount due upon complainant's said mortgage; (2) that defendants, or some of them, may be decreed to pay to complainant the amount found due, with interest thereon, by a short day to be appointed by the court, and that in default thereof, a foreclosure may be decreed; (3) that the said premises may be sold by order of the court, and out of the proceeds of sale complainant may be paid the amount found due upon his said mortgage, with interest thereon, and the costs of suit. The bill then prays that defendants may answer the bill fully and particularly, and sets forth certain interrogatories which it prays may be answered by George Booth and Ella, his wife, and certain other interrogatories which it prays may be answered by Frederick J. Howlett, and certain other interrogatories which it prays may be answered by the Dime Savings Institution of Plainfield. The bill contains no waiver of an answer under oath.

Separate answers were thereupon filed under oath in due course by George Booth and Ella Booth, by Frederick J. Howlett and by the Dime Savings Institution of Plainfield, respectively.

The complainant also called as his witnesses, George Booth and Frederick J. Howlett, defendants, and examined them particularly as to the circumstances under which the mortgages were given to Coonrod and Howlett, respectively. Booth testified as to the making and delivery of the mortgage to Coonrod substantially as set forth in the bill, and that he afterwards, on the same day, in pursuance of a previous arrangement, executed and delivered the mortgage for \$8,000 to Howlett; that he had told Howlett on a former occasion that the only lien on the property mortgaged was that created by the mortgage of the Mutual Life Insurance Company, and that \$5,000 on that mortgage had been paid, and that Howlett's mortgage was to be second to that and to that alone. He also testified that Howlett knew nothing of the Coonrod mortgage previously executed and delivered on that day, and that Howlett paid to him, after the delivery of the mortgage, and after Howlett had recorded the same, the full amount of the consideration named, to wit, \$8,000; that the same was paid in the following manner,—\$7,000 in gold, \$300 in greenbacks, and \$700 credited to a debt which Booth owed to Howlett for commissions and other transactions; that the payment was made in the house of Howlett, in Montclair, about 7 o'clock in the evening, which was after his return from the clerk's office, in Somerset county, where he had lodged the mortgage for record.

The complainant also called as his witness, Frederick J. Howlett, who testified to the same effect as Booth, to wit, that he paid the full consideration named in the mortgage, in his house about 7 o'clock in the evening, after he came back from recording the mortgage; that it was paid in gold, notes and by a credit in the manner testified to by Booth. In reply to further questions, he testified that he had accumulated the gold to an amount something over \$8,000 in his house through a period of several years. He also averred his good faith in the transaction, and testified that he had no knowledge from Booth, or otherwise, of the Coonrod mortgage; that he examined the records when he took his mortgage to Somerset county for record, and found the mortgage of the Mutual Life Insurance Company the only mortgage prior to his own; that he expected to find it there, as he had previously found it there, and that Mr. Booth had told him that there was such a mortgage as that; that when he offered the mortgage to the Dime Savings Institution, he represented it to be a first mortgage, the mortgage of the Mutual Life Insurance Company having, in the meantime, been canceled. This was substantially the only testimony offered by the complainants, bearing directly upon the question as to whether Howlett was an innocent mortgagee for full consideration and without notice.

The bill, as already stated, did not waive an answer under oath by the defendants, and the answers to the bill and to the interrogatories therein propounded were responsive, and were, in general tenor and effect, the same as the testimony given by Booth and Howlett, when called by the complainant, to which reference has just been made.

In other words, the testimony supports the answers in every respect. Being uncontradicted, these answers themselves are conclusive. The same rule applies to the answer of the savings institution, which is also not only uncontradicted, but clearly supported by the testimony in its behalf.

The testimony on the part of the Dime Savings Institution, the assignee of the Howlett mortgage, is to the effect that, when the mortgage was offered to them, in due course of business the property was examined by a committee of the directors, and an examination of the title was ordered to be made by its attorney, who afterwards reported that such examination had been made, and that the mortgage offered was a first lien upon the property described. The certificate of search set forth the Coonrod mortgage, dated May 1, 1899, and recorded May 6, 1899, as also the mortgage of the Mutual Life Insurance Company, canceled of record on May 8, 1899. This evidence clearly shows that it had no other knowledge than that stated as acquired from the records of Somerset county, and that it was believed by those controlling its affairs, that the Howlett mortgage was a first lien on the property named therein, under the statute of New Jersey relative to the record of mortgages. This statute is as follows:

"That every deed of mortgage, or conveyance in the nature of a mortgage, of or for any lands, tenements or hereditaments, which shall have been made and executed after the first day of January, in the year of our Lord one thousand eight hundred and twenty one, or shall hereafter be made and executed, shall be void and of none effect against a subsequent judgment creditor, or bona fide purchaser, or mortgagee, for a valuable consideration, not having notice thereof, unless such mortgage shall be acknowledged or proved according to law, and recorded, or lodged for that purpose with the clerk of the court of common pleas of the county in which such lands, tenements or hereditaments are situated, at or before the time of entering such judgment, or of recording or lodging with the clerk as aforesaid, the said mortgage or conveyance to such subsequent purchaser or mortgagee; provided, nevertheless, that such mortgage as between the parties and their heirs be valid and operative." Gen. St. N. J. p. 2106, § 22.

The question, then, for this court, as was the question for the court below is, (1) Was the Howlett mortgage made bona fide for a valuable consideration? and (2) was Howlett, at the time of the delivery of the mortgage and the payment of the consideration, without notice of the mortgage executed and delivered a few hours previously by the same mortgagors to Coonrod?

Undoubtedly, the burden was upon the complainant, Coonrod, to establish to the satisfaction of the court one or both of these averments of his bill. This he has been unable to do. He has been compelled to rely upon the testimony of Booth and Howlett, the mortgagor and mortgagee, made defendants by the bill. By this testimony he is bound, unless he can, by other witnesses and evidence, direct or circumstantial, show that their testimony is false. A complainant, who places the defendant on the stand, is not bound to refrain from contradicting him, where the exigency of the case demands it. In the case before us, however, there has been no testimony adduced to contradict that of Booth and Howlett. Whatever of improbability or suspicion may attend it, owing to the peculiar facts or circumstances of the case, it is not sufficient to countervail the effect of the direct testi-

mony brought out by complainant from the defendants whom he called upon to testify. The fact that the Coonrod mortgage does not come within the exception of the statute,—that is, that it was not placed upon record in the proper office for recording deeds, at the time, or prior to the recording of the Howlett mortgage,—is indisputable, and the priority of record must control the priority of lien, as between these two mortgages.

The complainant, however, further contends that the savings institution had notice of the Coonrod mortgage, before it took the assignment of the Howlett mortgage, and before it paid its money, and that this fact was enough to put the savings institution upon inquiry in regard to the Coonrod mortgage. It is not contended that the savings institution had actual notice of the facts in regard to the execution and delivery of the Coonrod mortgage, or that it was a participant in any actual fraud. The sole contention is, that its attorney, in making a search of the records for the condition of the Booth title, prior to its taking the assignment of the Howlett mortgage, or paying a consideration therefor, must have discovered upon the record the Coonrod mortgage, dated May 1, 1899, and recorded May 6, 1899, three days after the record of the Howlett mortgage. As to this contention, we need only say that the counsel who made the search, and the savings institution, were justified in standing upon the priority of lien that presumptively attaches to priority of record, and when complainant failed to show that the mortgagee of the mortgage, of which it took the assignment, had not paid a valuable consideration, or that he had notice of this prior mortgage, its rights under the assignment were secure, and it stood in the shoes of the mortgagor. Assuming that the presumption of innocence on the part of Howlett, as mortgagee of the subsequent mortgage, either as to the payment of valuable consideration or as to notice, has not been overthrown, as in this case it has not been, then, even if the savings institution, upon inquiry, had discovered the real fact as it existed, to wit, that the Coonrod mortgage had been delivered a few hours prior to the execution and delivery of the Howlett mortgage, it would still hold the title of its innocent assignor.

It should be observed, however, in this connection, that the mere disclosure upon the records in the office of the county clerk, that the Coonrod mortgage, though not placed upon record until May 6, 1899, was dated May 1, 1899, did not show or even tend to show that the Coonrod mortgage was actually delivered by the mortgagor to the mortgagee prior to the execution and delivery of the Howlett mortgage, or to the 3d of May, the date of record of the latter. No presumption arose from its date of May 1, 1899, that it was delivered and became a deed upon that day. As a matter of fact, we have seen that it did not become such until the 3d of May, the very day upon which the Howlett mortgage was made, and, according to the testimony, only about two hours before the delivery of that mortgage. So far as anything in the record of the mortgage was concerned, it might have been delivered two hours after the Howlett mortgage, or three days after.

It remains for us to consider the only other question in the case, namely, is the appelland, under the facts disclosed, entitled to be sub-

rogated as against the respondent (the Dime Savings Institution) to the rights of the Mutual Life Insurance Company of New York, in its mortgage, as they existed at the time it was paid off?

Howlett knew of the existence of the Mutual Life Insurance Company's mortgage at the time he took his mortgage from the Booths, and if the question of subrogation was against him alone, a different case might be presented. But we are dealing here with an assignee, whom the record shows to have been an assignee in good faith for valuable consideration and without notice. In fact, it was notified by Howlett, and the records of Somerset county corroborated his statement, that the Mutual Life Insurance Company mortgage had been canceled some weeks before the assignment to it. It was entitled to rely on the condition of the records as disclosed at the time of the assignment, and should not be defeated or prejudiced by a latent equity. No negligence is chargeable to the Dime Savings Institution in taking the assignment. It carefully examined the records, and, as we have shown, found nothing there to even put it upon inquiry as to the Coonrod mortgage. It would be unjust and contrary to public policy, as expressed in the statutes governing the record of deeds, that one who had taken an assignment under such circumstances, should be prejudiced without fault on his part. On the other hand, Coonrod was clearly negligent in not sooner recording his mortgage, of which he had delivery on the 3d of May, and in not examining the records up to the time that he lodged his mortgage for record in the office of the clerk of Somerset county. If he had made such examination, he would have discovered the mortgage of Howlett, and he would at least have refrained from paying off or having canceled the mortgage to the Mutual Life Insurance Company. This latter was his voluntary act, and was one which the respondent was justified in acting upon. The familiar rule in equity is applicable here, that where one of two innocent parties must suffer by the fraudulent conduct of a third, the one who has, by his negligence or omission to do something that a prudent man under the circumstances should do, enabled the fraud to be committed, must suffer the loss occasioned thereby.

The decree of the court below is affirmed.

POSTUM CEREAL CO., Limited, v. AMERICAN HEALTH FOOD CO.

(Circuit Court of Appeals, Seventh Circuit. October 21, 1902.)

No. 873.

1. TRADE-MARKS—INFRINGEMENT.

The trade-mark "Grape-Nuts," adopted as the name of a cereal food preparation, is not infringed by the name "Grain-Hearts," used to designate a similar product.

2. SAME—UNFAIR COMPETITION.

The labels and packages used by complainant for its cereal food preparation, "Grape-Nuts," and those used by defendant for its similar product,

¶ 2. Unfair competition, see notes to *Scheuer v. Muller*, 20 C. C. A. 165; *Lare v. Harper & Bros.*, 30 C. C. A. 376.

"Grain-Hearts," compared and taken as a whole. *held* so dissimilar in appearance that purchasers of ordinary intelligence, using ordinary attention, would not be likely to be misled into purchasing one for the other, and that defendant could not be charged with unfair competition in the absence of evidence that purchasers had actually been deceived.

Appeal from the Circuit Court of the United States for the Eastern District of Wisconsin.

The appellant, complainant below, filed its bill alleging the pirating by the defendant below, appellee here, of its trade-mark, and also of unfair competition in trade, with respect to the placing upon the market and sale of a certain cereal preparation designated "Grape-Nuts." The bill charges substantially that the complainant was possessed of a certain secret formula for a food product composed of wheat and barley, of distinctive appearance in texture and color, of a peculiar brownish color, of granular form, and of a crisp and brittle texture, easily masticated and readily soluble in water, and quickly digested, to which it had given the name "Grape-Nuts," as indicating the origin and source of manufacture. This name was placed upon the labels and packets containing the product in the form of a compound word connected by parallel hyphens, and appearing upon substantially plain type in light color upon a dark band extending across the label or package. Above this word are the words "Fully Cooked, Pre-Digested," and also the words "Dextrose and Grape Sugar." Below are the words "A Food for Brain and Nerve Centres." The word and trade-mark "Grape-Nuts" was registered June 14, 1898. The declaration in the statement for registration contains the following: "Upon the edge of the package appear the words, in plain black type, 'Genuine Grape=Nuts,' in connection with the autograph of C. W. Post. The entire printed matter, with the exception of the words 'Grape=Nuts,' is printed in black upon a yellow or buff colored label which envelopes the package containing the food, 'Grape=Nuts' appearing in yellow or buff like the label; but the color of the label, the style and color of type, and the various items of printed matter and other accessories above referred to, may be varied at pleasure or altogether omitted, without materially altering the character of the said trade-mark, the essential feature of which is the words 'Grape=Nuts.'" The bill also alleged that the product was placed upon the market in packets of "peculiar form, size, shape, capacity, and material, the packages having thereon a peculiar label, both in color of background, in color of type and literary matter, and arrangement thereof, namely, an angular six-sided box, about five inches in height, about four inches in width, and about two inches in thickness, having a label covering the entire six sides thereof, the background of which label is a light yellow, and has entirely extended across the back and front sides thereof a dark band about seven-eighths of an inch wide, and having thereon the double-hyphenated words 'Grape=Nuts' in plain light type, on one side of both of which bands appear among other things the words 'Fully Cooked, Pre-Digested,' 'Dextrose and Grape Sugar,' 'Made by Special Treatment of entire Wheat and Barley.' And on the other side of which band appear the words 'A Food for Brain and Nerve Centres.' * * * The hyphenated words 'Grape=Nuts' or 'Grape=Nut' also appearing upon all sides of said packet, and, with the exception of the word and trade-mark 'Grape=Nuts' on said bands, said bands and words and literary matter in blue ink on such light yellow background." The bill charged that the defendant below, appellee here, had produced and placed upon the market a food product substantially identical in texture, color, and other peculiarities to the product designated as "Grape=Nuts," and designated and labeled with the double-hyphenated word "Grain=Hearts" in plain type, in like color, and extending across the label and package. "Which hyphenated word, with such light type and dark band, your orator is informed and believes, and therefore avers, are so similar in appearance, sound, and arrangement that they are calculated to deceive and do deceive the ordinary purchaser into purchasing the defendant's product, believing it to be the genuine product of your orator; that the packages in which the product of defendant is put upon the market are identically of the same form, size,

and capacity as those of the complainant, inclosed by a label in the same manner as in complainant's patent, with the same peculiar yellow background as the label of the complainant, with printed matter thereon in blue ink, and of substantially the same context and arrangement as the complainant's, and in the same, or substantially the same, colors and style of lettering."

The answer denied that the complainant originated the particular form, and contrasting labels, colors, letters, style of letters, and wording thereon, used upon its packages; denied that it originated the formula under which the food product was manufactured, or the form and particular size and capacity of packets for containing the food product; denied that the lettering and the arrangement and color were unusual; but alleged that the size and form of the package for different products are governed by considerations of the cost thereof to the manufacturer; that the thick paper or cardboard from which cartons or packets are made, such as are used by the complainant and by the defendant in putting up and marketing their several products, are furnished by the paper mills, of a standard, arbitrary, and uniform size, being governed by the weight of a pound package of the product, to conform to the settled habits of the trade to sell food products in one-pound packages, or in packages containing a fractional multiple of a pound weight. The face of the complainant's package is here reproduced. [See Fig. 1.]

The back of the packet is substantially the same, except that directions for use are substituted for the imprint below the words, "A Food for Brain and Nerve Centres." Each end of the carton has printed thereon in black lettering upon yellow ground the following: "Genuine Grape=Nut Packages have the signature of the originator on the ends of each package, C. W. Post." One side of the carton has printed thereon "Directions for Use," the other a recommendation to athletes and brain workers, and with respect to the supposed virtues of the cereal product; all appearing in black lettering upon a yellow ground. The face and back of the defendant's package are alike, and are here reproduced. [See Fig. 2.]

Each end of the carton has printed thereon upon yellow ground the oblique blue band upon the red heart, with the double-hyphenated compound word in white letters "Grain=Hearts," and above and underneath the band the words in black lettering "Only the Genuine Have This Trade-Mark." One end of the carton has upon yellow ground the oblique blue band upon the red heart near the top of the carton, with the double-hyphenated word "Grain=Hearts" in white lettering, and above it in black ink the words, "Cooked Ready for Use," "A Brain and Nerve Food," and below it in black ink the words, "A Perfect Food for Athletes," following which are directions for use. The other end has the same imprint of a red heart and oblique blue band and trade-name, with the words above it in black ink, "Ready for Use. Nutricious. Delicious," and below, in like ink, "A Great Brain, Nerve and Muscle Food, containing all the known food elements, a very economical Food," and directions for use.

At the hearing the bill was dismissed for want of equity. (C. C.) 109 Fed. 898. From the decision dismissing the bill for want of equity, the complainant below appealed to this court.

Philip Mauro and George W. Mechem, for appellants.
E. H. Bottum, for appellee.

Before JENKINS, GROSSCUP, and BAKER, Circuit Judges.

JENKINS, Circuit Judge. We have so often spoken to the subject of unfair trade, and the law upon that subject is so well established by the repeated decisions of the ultimate tribunal and of the various circuit courts of appeals, that reference to the decisions would be superfluous. The principle is settled that:

"One may not legally use means, whether marks or other indicia, or even his own name, with the purpose and to the end of selling his goods as the goods of another. If such means tend to attract to himself the trade that

Fig. 1.

CUT HERE.

Run a sharp knife along the dotted line and squeeze the edges of box to make it gap. See that gap is closed after the required amount of food is poured out. Don't cut too off.



**FULLY COOKED,
PRE-DIGESTED.**

Dextrose and Grape Sugar,

Made by Special Treatment of Entire Wheat and Barley.

Grape-Nuts

REGISTERED IN UNITED STATES PATENT OFFICE.

**A FOOD FOR BRAIN AND
NERVE CENTRES.**

The System will absorb a greater amount of nourishment from 1 Pound of Grape-Nuts than from 10 Lbs. of MEAT, WHEAT, OATS OR BREAD.

COSTS ABOUT ONE CENT PER MEAL.

"ECONOMY."

Four heaping teaspoons of Grape-Nuts for the cereal part of a meal is the limit for an ordinary person. The food is condensed, and a small quantity supplies more nourishment than a large dish of the more bulky cereals. BE MODERATE.

Grape Nuts are unlike any other preparation.

Postum Cereal Co., Lim., Battle Creek, Mich.

Fig. 2.

COOKED READY FOR USE.

**A
BRAIN
FOOD**

GRAIN=HEARTS

**A
NERVE
FOOD**

**DELICIOUS
NUTRITIOUS**

**THE REAL NUT OF GRAINS.
SCIENTIFICALLY PREPARED
FROM ENTIRE WHEAT AND BARLEY, PRODUCING THAT
Delicate Grape-Sugar Flavor.**

A CONDENSED HEALTH FOOD

➤ PREDIGESTED ⚡

Equal to many times the same quantity of Bread or Meat.

AMERICAN HEALTH FOOD CO., Milwaukee, Wis., U.S.A.

would have flowed to the person previously accustomed to use them, their use will be restrained by the law." *Pillsbury v. Flour Mills Co.*, 12 C. C. A. 432, 64 Fed. 841.

In other words, no one may lawfully so dress his goods that he can palm them off as the goods of another manufacturer. We have no disposition to recede in the slightest degree from the law as declared by this court. It only remains to consider whether the appellee has so dressed his product, and whether there is such similarity in the carton used by the parties, that the purchasing public would be apt to mistake the goods of one for those of the other. We pass the question of the alleged piracy of trade-mark with the statement that we are unable to say that the compound word "Grain-Hearts" can possibly be deemed an infringement of the technical trade-mark "Grape-Nuts." They are not *idem sonans*; and, as suggested in the opinion of the court below, are "dissimilar in sound, appearance, and suggestion."

There is in this record no evidence produced by the complainant below of any actual mistake, or purchase by the public of the goods of the defendant as the goods of the complainant. There is no evidence that the dress of the one would be mistaken for the dress of the other. The defendant's evidence is that of sellers at retail, and to the effect that the one is not likely to be mistaken for the other. The complainant lays some stress upon the testimony of one of these witnesses that he had occasionally substituted one for the other by mistake; but he explains that the reason was because the goods were placed on a shelf side by side, and in the haste of business he took one for the other without looking, and he concluded with the significant remark that in all such cases "they were returned to us as the wrong article, and not the article called for." We do not mean to say that proof of the existence of actual deception of purchasers is essential. In the case of a manifest liability to deception, there need be no such proof; but, unless the dissimilarity is so marked that the court, upon inspection of the label, is fully persuaded that the public cannot be imposed upon by the dress of the article, there should be proof of actual mistake by purchasers. In respect to proof of actual mistake in the case at bar, the evidence is wholly with the defendant below. But aside from that, we are constrained to say that, upon the face of these labels, we perceive no such similarity as would impose upon a purchaser exercising the ordinary inattention of purchasers. We should be quite content to rest our decision upon the argument of the opinion of the court below, contained in the statement of the case, but we add a few suggestions.

It was strenuously insisted that the officers of the defendant had fraudulently sought to imitate the goods of the complainant: First. By imitating an article said to be the only one of its class, namely, a product produced by the mixture of wheat and barley. In this we think the complainant is mistaken. If it be assumed that the complainant was the first to produce such a compound, it nevertheless does not remove the article from the class of cereals or breakfast foods with which the country is overrun. Such foods, composed wholly of wheat, of wheat and rye, or of wheat and oats, are quite common, and it was the free right of every one to put upon the

market a mixture of wheat and barley. The complainant must rely upon the dress given to the package which contained the product of the defendant. Second. It is claimed that the name is of similar general character, and in many features identical; that the package used by the defendant is the same in size and shape, and identical in its three dimensions; that the background is of the same color, with the same distinctive features of dress, color, and arrangement, and therefore the competition is unfair. We need not enter into discussion of the conflicting evidence with respect to the intention and motive of the officers of the appellee, because that is of no moment, if the dress itself is not calculated to deceive purchasers. *Centaur Co. v. Marshall*, 38 C. C. A. 413, 97 Fed. 785. The question recurs whether we can say that these labels are apt to be mistaken, the one for the other. There may be, indeed, some minor points of resemblance; but we should look at the matter as a whole,—both at the resemblances and the differences,—to ascertain whether, in view of the differences, the resemblances are so marked that the ordinary purchaser would be likely to be deceived, and should look at the subject in the manner suggested by Mr. Justice Brewer in *Lorillard Co. v. Peper Co.*, 30 C. C. A. 496, 86 Fed. 956, that:

“In determining the question of fraudulent imitation of packages and labels, merely noting the points of difference or similarity is not sufficient. The packages and labels must be considered as a whole.”

The question resolves itself to this: Whether these two labels are so alike that one of ordinary intelligence, desiring to purchase the one product, would be misled into purchasing the other. The ordinarily inattentive purchaser is attracted by sound and color, and possibly to some extent by the size of the package. It appears here that the question of size in the manufacture of the carton for cereals is determined by the proprietors of the paper mills manufacturing them, by the size of a pound of the product, and that all cereal food is sold in like packages. It is proven, also, that a large proportion of packages containing cereal food, before the placing of “Grape=Nuts” upon the market, was of a yellow background. The background of the two packages in question is somewhat similar in color, although that of “Grain=Hearts” is of a lighter shade than that of “Grape=Nuts.” But there are certain distinctive marks which are peculiarly suggestive to the eye, which, in our judgment, so stamp these labels and indicate such marked dissimilarity that we think the purchaser who, relying upon his knowledge of the character of the brand he wished, should mistake the one for the other, would be stupid indeed. The band in the complainant’s label upon which is imprinted the compound word “Grape=Nuts” in yellow lettering, extends directly across the face of the package, and is said to be of a dark blue color, although it is hardly distinguishable from black. The band upon the defendant’s package runs obliquely across the face, and is of a bright blue color, with the compound word “Grain=Hearts” upon it in white letters, and this band runs across a large red heart, prominently displayed. This device appears upon every side of the defendant’s package, while the band of the complainant’s package is only upon the face and back. The distinguishing feature of the defendant’s

label is the red heart. It is so marked and so pronounced that one could not fail to see it, and it would challenge the attention of any person,—even a stupid person,—who, seeking to purchase the product of the complainant, and knowing its label, should be presented with the product of the defendant.

The point of resemblance insisted upon in the use of the double hyphen in the compound word appears to us of slight moment. It is unusual, indeed, to use the two parallel lines; but we doubt if any but the most observant purchaser would notice it. An inattentive purchaser, using the slightest care, would observe the distinguishing feature of the red heart a hundred times where the careful and attentive purchaser would notice the double hyphen once, and the latter, observing it, would not be deceived, for that same care would disclose the prominently displayed red heart peculiar to the one and absent in the other.

We need not pursue the subject. We are fully satisfied that the dissimilarities are such, and are so pronounced, that the one label is not likely to be mistaken for the other.

The decree will be affirmed.

THE FONTANA.

(Circuit Court of Appeals, Sixth Circuit. January 6, 1903.)

Nos. 1,110, 1,111.

1. COLLISION—VESSELS WITH TOWS MEETING—SUCTION DUE TO OVERTAKING STEAMER.

The Interocean, an overtaking steamer, attempted to pass another steamer having a barge in tow going up the St. Clair river, but the towing vessel refused to assent to her signals, and she desisted, but kept alongside of the barge for some time, but at a safe distance, at no time less than 100 feet, until the towing steamer was passing a meeting vessel, also with a tow, when the Interocean swung in toward the barge, and within from 30 to 60 feet, and almost immediately the stern of the barge swung to port, and she sheered to starboard, striking and sinking the passing tow, which was on a course 150 feet distant. Up to that time the barge was following her steamer closely, and was under a starboard wheel, to counteract the effect of the current, which was put hard astarboard as soon as the sheer was felt. No fault in the management of the barge was shown. *Held* that, while she had the burden to clear herself from fault in the deviation from her course, she did so when she showed that she was following her steamer, and was in the exercise of due care, and that she used all reasonable means to break the sheer; that under the facts shown the sheer must be attributed to the suction caused by the Interocean, and she must be held solely in fault in failing to keep at a safe distance, taking into account the danger from suction, as was her duty as an overtaking vessel.

2. SAME—TOTAL LOSS OF VESSEL—MEASURE OF DAMAGES.

Where a vessel is sunk in collision, and damages are awarded on the basis of her total loss, including interest on her value and her pending freight, the owner is not entitled to damages for loss of future earnings under an unexpired charter.

¶ 2. See Collision, vol. 10, Cent. Dig. § 282.

Appeals from the District Court of the United States for the Eastern District of Michigan.

The barge *Fontana* came into collision with the barge *Santiago* and was sunk almost instantly, the loss being practically total. The *Fontana* was bound down the St. Clair river in tow of the steamer *Kaliyuga*. The *Santiago* was bound up the river in tow of the steamer *Appomattox*. The collision occurred near the mouth of the river, a little below and nearly abreast of the Fort Gratiot light, and slightly on the Canadian side of the range line. The channel is at that point about 1,100 feet wide, the sailing range running about 500 feet from the American shore line. The current at the point of collision is very stiff, running between four and five miles per hour. The mouth of the river is funnel-shaped, and the current flows in from either side toward the center, but at the point of collision it follows substantially the range line, with a slight trend toward the American shore. The *Kaliyuga* was 269 feet long and 40 feet wide. The *Fontana* was 231 feet long and 39 feet wide, and was on a tow line about 800 feet long. The *Appomattox* was 319 feet long and 42 feet wide. The *Santiago* was 324 feet long and 45 feet wide, and was on a tow line of about 900 feet long. All were heavily laden. The collision occurred about midnight, the night being dark but clear, and there was no wind. When the two tows were within about 1½ miles away, passing signals of two blasts were exchanged. At this time another steamer, which afterwards proved to be the *Interocean*, was showing lights indicating that she was coming up the river, a short distance to the westerly of the *Kaliyuga* and on a course parallel with the *Kaliyuga* and nearly abreast of the tow of the *Appomattox*. Having received but one signal from the two up-bound steamers, and being uncertain whether that was from the lone steamer or the towing propeller, the *Kaliyuga* repeated her signal of two blasts and checked down to about a speed of seven miles. This was again replied to by the *Appomattox*, and was recognized as coming from her. The two steamers approached on courses which enabled them to pass at a distance of about 150 feet apart, the *Appomattox* being a little to the westerly of the range line and the *Kaliyuga* a little to the easterly of that line. Just as the bow of the *Kaliyuga* was about abreast of the stern of the *Appomattox*, the *Santiago*, which up to that time had been well following her steamer, suddenly sheered to her starboard and toward the course of the *Kaliyuga* and her tow, the *Fontana*. The bow of the *Santiago* rubbed slightly against the starboard quarter of the *Kaliyuga*, and, passing nearly under her stern, followed the tow line, and came violently in collision with the *Fontana*, causing her to sink almost instantly. The owner of the *Fontana* libeled the *Appomattox*, the *Santiago*, and also the *Interocean*, alleging faults against each. The owners of the *Appomattox* and the *Santiago*, the St. Clair Steamship Company, answered separately for each vessel, and cited in the *Kaliyuga* and *Fontana*, and filed a cross-libel against them and the *Interocean*, charging that the fault was wholly that of the cross-libelees, or that they had contributed. District Judge Swan acquitted all but the *Santiago*, holding that barge solely responsible, and dismissed the libel and cross-libel as to each of the other vessels. From this decree the Boston Coal Dock & Wharf Company, owner of the barge *Santiago* and steamer *Appomattox*, has appealed from so much as holds its barge *Santiago* at fault, and in so far as the decree dismisses the libel as to the steamer *Interocean* and exonerates libelants' steamer *Kaliyuga* and its barge *Fontana*. The St. Clair Steamship Company, libelant and cross-libelee, also appealed from the decree holding that the cross-libelants' steamer *Appomattox* was not in fault, and that the steamer *Interocean* was without fault, etc.

John C. Shaw, for the St. Clair S. S. Co.

Harvey D. Goulder and Harrington Putnam, for the Boston Coal Dock & Wharf Co.

Robert T. Gray and F. H. Canfield, for the *Interocean*.

Herman Kelley, for the *Fontana*.

Before LURTON, DAY, and SEVERENS, Circuit Judges.

LURTON, Circuit Judge, after making the foregoing statement of the case, delivered the opinion of the court.

The two tows approached each other under passing signals, and in plain sight each of the other, and sailing on courses which would, if maintained, enable the Kaliyuga, and her tow, the Fontana, to pass at a safe distance on the starboard hand of the Appomattox and her tow, the Santiago. This course was kept until the steamers were almost abreast, the bow of the Kaliyuga being abreast of the stern of the Appomattox. Just at this moment the Santiago, which had up to this time followed very closely in the wake of the Appomattox, suddenly took a sheer to starboard, and came into collision, first with the Kaliyuga, and then with the Fontana. The Santiago was under obligation to follow her steamer. This she did not do, but suddenly changed her course and crossed the course of the passing down tow in such manner as to result in a collision. It is very clear on reason and authority that the Santiago is called upon to excuse this very extraordinary navigation, or stand condemned upon the presumptions arising from evidence that she did not follow her steamer, but deviated and crossed the course of the passing tow. Now, what is the excuse for this divergence from the wake of the Appomattox? The libel of the Fontana charges that this sheer was due to the suction produced by the Interocean passing so close on her port side as to draw "her stern toward and with her, throwing her bow in the opposite direction, to starboard, causing her to sheer in the direction of the Fontana." The answer of the Santiago admits that she sheered, and charges that her sheer was caused by the Interocean negligently coming so close alongside as to cause her to sheer to starboard "against a starboard helm." As between the Fontana and the Santiago there is, therefore, no issue as to the initiation of the sheer. But if the descending tow was on its proper course, and in the exercise of due caution, this is not enough to acquit the Santiago, for as to the innocent Fontana her defense must go farther and show that she was in the exercise of due care when she came under the influence of the Interocean's suction, and that she exercised all reasonable diligence to break the sheer before colliding with the passing tow. The evidence clearly acquits the Fontana of all fault, and she would undoubtedly have passed the Santiago at a distance of not less than 150 feet on her starboard side if the latter had followed the wake of the Appomattox, as she was bound to do under her passing signals. Under such circumstances, the burden of proof continues with the Santiago until she shall show that her deviation from the wake of her steamer and her sheer across the bow of the Santiago was without fault upon her part. This is the well-settled rule in such cases, and has been over and over enforced by this court. *The Olympia*, 9 C. C. A. 393, 61 Fed. 120; *The F. W. Wheeler*, 24 C. C. A. 353, 361, 78 Fed. 824; *The Ohio*, 33 C. C. A. 667, 91 Fed. 547; *The Centurion*, 40 C. C. A. 634, 100 Fed. 663. There is no departure from this rule of evidence in the case of the *Centurion*. The question there was as to which of two passing vessels was at fault for the sheer of one by which she was brought into col-

lision with the other. No innocent third vessel was involved. No reference is made to any question of burden of proof, and the Marshall, the sheering steamer, was acquitted because the evidence affirmatively established that she had been guilty of no fault in her steering or equipment. The claim that her sheer was due to the negligence of the Centurion in passing too close was not made out, and both libel and cross-libel were dismissed because on all of the evidence neither had established fault against the other. But we think the defense of the Santiago is made out. Aside from any effect to be attached to the pleading, as between the Santiago and the Fontana, we think her sheer was initiated by the suction of the Interocean. Twice or three times the Appomattox refused the Interocean's request to pass up on her port hand. It is not essential that this should have been denied upon thoroughly good reasons, or that the master of the Appomattox discriminated arbitrarily in consenting a few moments before that another and larger steamer might pass up on the same side. The master of the Appomattox based his action, so far as his attention seems to have been directed to the matter, upon the ground that the channel was narrower and the current stiffer when he denied what he had before granted to another steamer. The first steamer was also faster than the Interocean, and this seems to have had some weight in influencing his judgment. In her anxiety to gain time, the Interocean pushed up until she was abreast of the Santiago, and, on the third denial of her request, checked. But this checking had so slight an effect as to result in no substantial change in her position, though it did have more or less influence in satisfying the master of the Appomattox that she would make no further immediate effort to pass him. For nearly two miles the Interocean continued alongside and nearly abreast of the Santiago, sometimes pushing a bit ahead, and then dropping a little behind. But for something over a mile preceding the collision she continued substantially abreast. The claim of the master of the Interocean that she was never abreast, but always astern, is contradicted by the very decided weight of the evidence. Until just prior to the Santiago's sheer, the weight of the evidence fixes the Interocean, after she had pushed up alongside, as never less than 100 feet away from the port side of the Santiago, and that this distance varied from that up to 150 feet. There is no evidence, expert or otherwise, tending to show that any danger from suction was to be reasonably anticipated so long as the passing vessels did not draw closer together than 100 feet. Upon this ground we think that no fault is to be found with the Appomattox for not stopping or checking so as to permit the Santiago to drop astern of the Interocean. The Santiago was the overtaken vessel, and it was the duty of the Interocean to keep off and allow a safe margin against the influence of suction from either vessel. But so long as the Interocean kept as much as 100 feet away, her proximity did not demand any special and unusual precautions to avoid the effect of suction. The duty of so steering as to keep properly in the wake of the Appomattox was the primary duty resting upon the Santiago. It was the duty of the Interocean if she came up abreast or passed or attempted to pass, to keep at a distance which would allow a safe margin against every reasonable anticipation of danger of suction or

other danger due to or increased by proximity to the Santiago. That the Santiago should keep under a starboard helm, in view of the current into which both vessels were heading at the time of the sheer, was dictated by the rules of safe navigation. But, according to all of the evidence from the deck of the Santiago, she was under a starboard helm when she started to sheer, and the helm put hard astarboard so soon as the sheer begun. The district judge, speaking of the sheer of the Santiago, said:

"The cause of her sheer can only be conjectured. My surmise is, and it is only a surmise, that she was suffered to get away a trifle to starboard, and the current caught her port bow and swung her across the course of the tow."

But this "surmise" is only made plausible, in the face of the positive evidence of the master and wheelsman of the Santiago, by rejecting the evidence tending to show that the sheer was started through the influence of the Interocean's suction. But the learned and experienced admiralty judge acquitted the Interocean with great reluctance, declaring that the evidence cast a "strong suspicion upon her," but saying, "The proofs are not demonstrative of the fault of the Interocean." Touching the probable influence of suction, he said "that the proofs are persuasive that, notwithstanding the disparity in tonnage between her and the Santiago, if she were as close as stated (by the crew of the Santiago),—some thirty feet,—that, moving as she was by her own power, the force of suction in that locality and in those conditions would very easily so far deflect the Santiago from her course as to throw the current on her port bow and account for her paying off as rapidly as she did, and shooting out in the path of the Kaliyuga and Fontana. She must have shot out then at a very high rate of speed, at least 150 feet, for there is no evidence of a change of course on the part of the Kaliyuga." But we think the learned judge erred in demanding that the evidence to convict the Interocean should amount to what he calls a "demonstration." Undoubtedly the Santiago is not to be acquitted merely by showing that she was caused to sheer by the influence of suction from the Interocean. In the case of the Ohio, where the facts were much like those of this case, the Ohio having been sunk by a collision with the Siberia, which claimed as a defense that her sheer had been caused by the too close approach of the Mather, we said:

"But the Siberia does not exonerate herself from liability to the Ohio by simply showing that she thus came within the influence of the 'suction' of a passing steamer. The Ohio has the right to call upon her to show that she was brought within this dangerous influence without fault, and that there was no fault in her management after this mysterious force began to exert itself upon her. Unless she can show that her deviation was due to a cause which she could not have reasonably avoided, how can it be said that the collision was inevitable,—that it was not occasioned in any degree by the want of such care and skill as the law requires and holds all men bound to exercise?"

But when the Santiago has shown that her sheer was caused by the influence of the Interocean's suction, and that she was not in fault for coming within the sphere of that influence or in respect to her management after the sheer commenced, she has shown that she was the blameless instrument of a collision for which the Inter-

ocean is responsible. By an "inevitable accident" we are not to understand an accident which could not have been avoided by any degree of care or skill. "Inevitable accident," says Dr. Lushington, in the case of *The Europa*, 2 Eng. Law & Eq. 559, "must be considered as a relative term, and must be construed not absolutely but reasonably, with regard to the circumstances of each particular case. Viewed in that light, inevitable accident may be regarded as an occurrence which the party charged with the collision could not possibly prevent by the exercise of ordinary care, caution and maritime skill." *The Morning Light*, 2 Wall. 550, 17 L. Ed. 862.

To recur to the circumstances immediately preceding the collision. We have referred to the fact that there was no reasonable danger to the navigation of the *Santiago* in the mere fact that the *Interocean* was abreast of her, so long as she kept so far as 100 feet away. But the *Interocean* did not keep as far as 100 feet away from the *Santiago*. Just before the sheer began she for some cause drew closer in, and when the sheer started had drawn in as near as 40 or 50 feet, and probably even as close as 30 feet. This drawing in, on the weight of the evidence, occurred quite suddenly, and was immediately followed by the starboard sheer of the *Santiago*. The evidence coming from the *Interocean* is so sharply in conflict with that of the witnesses from the other vessels that it is useless to try to reconcile the divergent views. According to the story told by the *Interocean* people she never did come abreast of the *Santiago*, and never was nearer than 150 feet of the course of the latter. Indeed, on the evidence from her deck, the *Interocean* was so far over on the port side of the *Santiago* that her first mate in charge of her navigation at the time of the collision says that she was sagging in so close to the American bank about as the *Kaliyuga* and *Appomattox* came abreast that he ordered her wheelsman to port a trifle, and that she dropped "out from the dock a trifle, and I checked her right off with the starboard wheel." This witness places the *Interocean*, at the time he gave this order to port, as within about 40 feet of the American bank, which he sometimes calls the "dock." This is in itself an unlikely story, as it places him unreasonably close to the American shore, so close that he was fearing shallow water might sheer him. Now this porting was done at the very moment the *Kaliyuga* and the *Appomattox* were passing each other, and that was the very moment when the *Santiago* began her sheer. As the overwhelming weight of the evidence establishes that when this sheering began the *Santiago* was some 400 feet out from the American bank, and that the *Interocean* had been for a mile running abreast and within from 100 to 150 feet, it is fairly inferable that this porting was the cause for the *Interocean* drawing so much closer to the *Santiago* as to cause her to feel the influence of suction. Heading, as the *Interocean* was, into a stiff current, it was an easy thing to get the current slightly on her port bow and draw closer to the vessel on her starboard hand than was intended. That just at the moment when the sheer commenced the two vessels had drawn in to within 30 to 60 feet is established by the weight of evidence, and that this was quite near enough to effect the navigation of

the Santiago we have no doubt. The current catching the Santiago's port bow would make it hard to quickly break the sheer and send her off, much as the evidence shows she went. All that she could do to guard against the possibility of sheering, or that she might reasonably be required to do, was, in the situation, to be under a starboard helm. After the sheer began her helm should have been put hard astarboard. But the evidence is undisputed that she was under a starboard helm when the sheer started, and had properly followed in the wake of her steamer up to that moment. Her helm, on the evidence of her master and both wheelmen, was starboarded as soon as the sheer started, and so far as we can see she was not in fault in getting within the influence of the Interocean's suction, or in her navigation, either just before or at the time or after the sheer. It follows that the Santiago, being in no fault, cannot be condemned, and the Fontana must, as between her and the Santiago, bear the loss due to an inevitable or blameless accident. The Interocean, for having violated her duty as an overtaking ship in approaching so close to the Santiago as to affect her by suction, must be held at fault.

We quite agree with the district court in the opinion that neither the Kaliyuga nor the Fontana are to be held liable. There is no evidence sustaining the charge against the Kaliyuga. The course she pursued, after exchange of passing signals, was in accordance with the understanding. The distance at which the two tows would have passed each other if the Santiago had followed in the wake of the Appomattox was a safe one. After the sheer commenced the Kaliyuga was checked, and her wheel put hard aport, and then hard astarboard, the purpose being to "twist" around the sheering Santiago. The weight of evidence is that it would have been wiser not to have checked, and better navigation to have kept full tension on the tow line, and thus a better control upon her tow. But the situation was one which required immediate action and allowed no time for reflection. It was a situation not brought about by the fault of either the Kaliyuga or her tow, and, if her master failed in the exigency (for the collision must have occurred within one minute from the beginning of the sheer), the Kaliyuga ought not to be condemned for an error of judgment in extremis. The Fontana closely followed her steamer, and, although she had no outlook at the time of the disaster, it is clearly shown that her master saw everything which a watchman could have seen, and adopted every precaution which reasonable navigation in the exigency of the case demanded. The Appomattox must also be acquitted. That her lookout had gone below just before the sheer of the Santiago is shown. This casts upon the Appomattox the burden of showing that the presence of the lookout would not have prevented the collision. *The George W. Roby*, 49 C. C. A. 481, 111 Fed. 601. It is clearly shown that her master saw everything and heard every signal which a lookout could have seen or heard, except that he did not see that the Interocean had come up abreast of the Santiago, and had been keeping about abreast for about 10 or 15 minutes before the collision. This was a fact which might have been sooner observed and re-

ported if the lookout had not gone below at about the time the Interocean checked. The last report by the lookout to the master was that the Interocean was dropping back a little. This was immediately after the third request of the Interocean for permission to pass up on the port side of the Santiago had been denied. The master acted upon the belief generated by the checking of the Interocean, and this report of his lookout that she was dropping back, and, for perhaps a mile before the sheer began, had not looked back to see her position, his attention being given to the approaching down tow. But if he had looked back, or if the watchman had been in his place and reported the situation, it was one which presented no reasonable danger from suction so long as at least 100 feet was maintained between the two vessels. Now, on the overwhelming weight of evidence, this distance or greater was maintained until just before the sheer began. This is the moment when the master of the Appomattox observed that the Interocean had drawn in close to his barge, and realized that there was danger from their proximity. If there was no reasonable ground to apprehend danger from the influence of suction so long as the Interocean was as much as 100 feet away from the Santiago, we are unable to see that her lookout's absence from his post in any way contributed to the disaster, or that his presence would have prevented it, for it would have been no fault if the master of the Appomattox, with knowledge of the facts, had kept his speed and course, in reliance that the Interocean as the overtaking vessel would come no nearer his tow, and thus avoid any danger incident to too close proximity.

There has been some claim that the steering qualities of the Santiago were bad, and that she was a craft very subject to sheers. This contention has been in part rested upon evidence offered and rejected tending to show that the boat had a bad reputation for sheering. No error, however, has been assigned for the exclusion of this class of testimony. The principal evidence admitted bearing upon this matter came from two witnesses who had for a short time sailed on the Santiago. But the district judge saw and heard these witnesses testify, and he took care to say in his opinion—made part of the record under the rule of this court—that he did not “believe their testimony,” and that, on the great preponderance of the evidence, “she was a good steering vessel.” Under such circumstances we should be slow to come to a different conclusion in respect of a fact where the credibility of the libelant's most material witnesses had been so directly challenged by the trial judge. *City of Cleveland v. Chisholm*, 33 C. C. A. 157, 90 Fed. 431. In view of the fact that this sheer is plainly and satisfactorily shown to have been started by the influence of suction, there is no reason to suspect either bad navigation or bad steering qualities as either starting or aggravating it. The conditions were exceedingly favorable for a dangerous sheer if one were but started, for with the current even slightly on the port bow of a vessel not having her own power it would be very easy to sheer far enough to the starboard side to collide with a vessel on a course only about 150 feet away. The same causes would make it very hard to break a sheer in time to avoid a collision with

vessels passing so near as was the case here. We held the *Siberia* had contributed to the collision with the *Ohio* upon a very different state of facts, involving a much wider sheer, and under conditions altogether favorable for breaking it. In addition, there was a conflict of ominous character as to the steerage of the *Siberia*. The *Ohio*, 33 C. C. A. 667, 91 Fed. 547.

A question has been made as to the damages. The loss of the *Fontana* was total, and her full value, with interest, together with her pending freight, was allowed. It is now insisted that her lost earnings under her charter should have been allowed also. Her charter was an oral contract to carry ore during the season of navigation at \$1.10 per ton, payment to be made at completion of each voyage for the ore carried. The disallowance of future profits under her charter was right. Further installments could only be earned as each voyage was completed. As a compensation the owners were allowed the full value of their vessel, and that value, with its interest, or the vessel procured with that value, stands in the place of the lost ship and its future earnings. The precise question was fully decided by this court on identical facts in the case of *The George W. Roby*, 49 C. C. A. 481, 495, 111 Fed. 601.

The decree of the district court will be affirmed as to the *Appomattox*, *Kaliyuga*, and the *Fontana*, and reversed as to the *Santiago* and *Interocean*. The cause will be remanded, with direction to enter a decree against the *Interocean* and to dismiss the libel as to the *Santiago*. The costs of these appeals will be paid as follows: One-third by the Boston Coal Dock & Wharf Company, and the remainder by Henry W. Watson, claimant of the steamer *Interocean*. The costs below will be taxed at the discretion of the district court.

UNITED STATES v. McCRORY.

(Circuit Court of Appeals, Fifth Circuit. January 27, 1903.)

No. 701.

1. **STATUTE—TITLE—EFFECT.**

The title is no part of an act, and cannot enlarge or confer powers or control the words of the act, unless doubtful or ambiguous.

2. **FEDERAL COURTS—JURISDICTION.**

A letter carrier had recovered judgment in the district court against the United States for extra compensation, and it had sued out a writ of error. Afterwards, but before the case was heard in the circuit court of appeals, Act June 27, 1898 [U. S. Comp. St. 1901, p. 753], was passed, amending Act March 3, 1887, thereby taking away the jurisdiction of the district court to entertain the suit, and the writ of error was, on motion, abated. Afterwards Act Feb. 26, 1900 [U. S. Comp. St. 1901, p. 758] was passed, which provided that no suit should abate or be affected by the act of June 27, 1898, which was pending in any circuit court of appeals, circuit or district court, at the time of its passage, "and all such suits which have been dismissed * * * shall be restored to their places within such courts." *Held*, that the action was plainly included within the terms of the latter act, and the cause was properly restored.

8. **SAME—CONSTITUTIONALITY.**

As all the proceedings under Act March 3, 1887 [U. S. Comp. St. 1901, p. 752], authorizing suits by officers against the United States to recover

fees, and amendatory acts, are permissive, and in the main intended to advise congress, and as judgments and decrees adverse to the United States are merely reported to congress for such action as it sees fit to take, the objection that the act of 1900 is unconstitutional is not entitled to be considered.

4. LETTER CARRIERS—EXTRA COMPENSATION.

Under Act May 24, 1888 [U. S. Comp. St. 1901, p. 2637], providing that letter carriers employed more than eight hours per day shall be paid extra therefor, a carrier was not entitled to extra pay for short intervals during which, while excluded from the office and not required to be in uniform, he was under the control and direction of the postmaster to the extent that he could be summoned at any time and assigned to duty.

In Error to the District Court of the United States for the Northern District of Alabama.

This is a suit brought by defendant in error, a letter carrier at the post office of Birmingham, Ala., to recover for alleged extra time which he claims he was employed over and above eight hours per day under an act of congress entitled "An act to limit the hours that letter carriers in cities should be employed per day," approved May 24, 1888 [U. S. Comp. St. 1901, p. 2637]. The claim amounts to \$253.26. The petition was regularly served. The United States answered denying the indebtedness.

The case was tried in the district court on an agreed statement of facts, as follows:

"James T. McCrory, Complainant, v. The United States, Defendant.

(No. 52.)

"It is hereby agreed by and between counsel for complainant and defendant in the above-stated cause that the amount herein sought to be recovered from the defendant arose under the following state of facts, viz.: That the complainant was from the 1st day of December, 1894, to the 1st day of February, 1896, a duly appointed and acting letter carrier in the employment of the United States (defendant) as such at the Birmingham, Alabama, post office, in the city of Birmingham, Alabama, at a salary of \$600.00 per annum. That his salary was on the 1st day of February, 1896, increased to the sum of \$850.00 per annum, and that the complainant continued in the employment of the defendant as such letter carrier at said salary of \$850.00 from the 1st day of February, 1896, to the 1st day of January, 1897. That during the aforesaid period from the 1st day of December, 1894, to the 1st day of February, 1896, while the complainant was receiving from the defendant a salary of \$600.00 per annum, there were daily intervals between the complainant's daily trips in collecting and delivering the United States mail in the city of Birmingham, varying in duration, but which in the aggregate amounted to 425 hours, at 20 $\frac{2}{3}$ cents per hour. That during the aforesaid period from the 1st day of February, 1896, to the 1st day of January, 1897, while the complainant was receiving from the defendant a salary of \$850.00 per annum as such letter carrier, the complainant had similar intervals daily between his said daily trips in collecting and distributing the United States mail in the city of Birmingham, Alabama, which in the aggregate amounted to 567 hours and ten minutes, at 29 $\frac{5}{24}$ cents per hour. That the said intervals between said daily trips were in number from two to three hours per day, and varied in duration as aforesaid from 30 minutes to 2 $\frac{1}{2}$ hours, according as the amount of mail for collection and distribution was large or small. That these idle intervals were exclusive and in excess of the 8 hours of actual and active service which the complainant performed as such letter carrier daily for the defendant. That during the said intervals the complainant was by the rules of the post office department excluded from the post office, but was under the control and direction of the postmaster to the extent that the postmaster had the right, power, and authority to summon the complainant to duty at any time during any of said intervals and send him out again col-

lecting or delivering mail, or assign him to any other duty within the range and line of his employment as such letter carrier. That during such intervals complainant was not required by the postmaster or any rule or regulation of the post office department to keep on his uniform, and could keep it on or discard it as he might desire, but that while on duty he was required to wear his said uniform. That, by reason of the said right, power, and authority of the postmaster to summon the complainant to duty at any time during any of said intervals, the complainant was prevented and prohibited from obtaining or accepting other employment during such intervals except such employment as should be subject and second to the right, power, and authority of the postmaster to at any time so summon the complainant to duty during any and all of said intervals, and the complainant could not and did not obtain other employment. That the complainant did not actually do or perform any work or service for the defendant during any of the intervals which makes the aggregates aforesaid, but was subject during all of said intervals to be summoned by the postmaster to duty as aforesaid within the line of his employment as such letter carrier, but was under the control and direction of the postmaster during said intervals as aforesaid. That, in computing the aggregate of said intervals aforesaid, the daily dinner hour from 12 to 1 o'clock p. m. is not included. It is further agreed that this statement of facts may be taken and considered by the court as the facts in each of the other 18 cases now pending seeking a similar recovery of the defendant, except as to the amount involved in each, respectively, and the court may in each of said cases pronounce its findings, conclusion, and judgment accordingly."

The trial judge found the facts to be as set forth in the foregoing agreement, and from that finding concluded that the petitioner was entitled by law to a judgment for the recovery of the amount claimed by him, and rendered judgment accordingly. From this judgment in due season the United States sued out a writ of error on February 28, 1898, and the transcript was filed in this court April 12, 1898. Before the case was heard on this writ, congress passed an act entitled "An act to amend sections 1 and 2 of the act of March 3, 1887," approved June 27, 1898 [U. S. Comp. St. 1901, p. 752], wherein the jurisdiction of the district and circuit courts to entertain suits against the United States, on the part of the officers of the United States, to recover fees for services rendered, was taken away; and thereupon, on motion of the defendant in error, the writ of error pending in this case was abated. See *U. S. v. McCrory*, 33 C. C. A. 515, 91 Fed. 295. Subsequently congress passed the following:

"An act for the relief of claimants having suits against the United States pending in the circuit and district courts of the United States affected by the act of June twenty-seventh, eighteen hundred and ninety-eight, amending the act of March third, eighteen hundred and eighty-seven.

"Be it enacted by the senate and house of representatives of the United States of America in congress assembled, that no suit shall abate or be affected by the act of June twenty-seventh, eighteen hundred and ninety-eight, entitled 'An act to amend sections one and two of the act of March third, eighteen hundred and eighty-seven,' which was pending in any circuit court of appeals, circuit or district court of the United States at the time of the passage of said act; and all such suits which have been dismissed by reason of said act shall be restored to their places in such courts and proceeded with as if the same had not been enacted; and time within which an appeal or writ of error may be taken or prosecuted in any case affected by this act is hereby extended six months from the passage hereof." Approved February 26, 1900 [U. S. Comp. St. 1901, p. 758].

On the presentation of this last-mentioned act and on motion of counsel for plaintiff in error, this court on May 12, 1900, ordered that this cause be restored to the trial docket to be proceeded with in accordance with law and the rules of this court, and thereupon defendant in error filed a motion to strike the case from the docket for the following reasons:

"(1) That the act of February 26, 1900, does not include the United States, and was not intended to confer any right upon the United States, but was

intended to include 'only claimants' having suits 'pending in the circuit court of appeals, circuit and district courts.'

"(2) That the act of February 26, 1900, is unconstitutional as to the case under consideration and those similarly situated, because it is an invasion and infringement by the legislative branch of the government on the judicial.

"(3 and 4) That the judgment had become final; was beyond the power of all or any courts to impair or interfere with; that the term had passed, the right of appeal had expired, when the act of February 26, 1900, was passed; that the case was pending in no court; the writ of error had been abated, and this court had no jurisdiction to set aside the judgment abating the writ of error, nor to restore it to the docket for any purpose.

"(5) That the act of February 26, 1900, violates the fifth amendment to the constitution of the United States; that the judgment was a vested right and property, which could not be impaired by subsequent legislation."

On this motion and on the merits the cause has been argued and submitted.

Wm. Vaughn, U. S. Atty.
Denson & Tanner, for complainant.

Before PARDEE, McCORMICK, and SHELBY, Circuit Judges.

PARDEE, Circuit Judge. "The title is no part of an act, and cannot enlarge or confer powers or control the words of the act, unless doubtful or ambiguous. *U. S. v. Fisher*, 2 Cranch, 358-386, 2 L. Ed. 304; *Railroad Co. v. Thomas*, 132 U. S. 174, 188, 10 Sup. Ct. 68, 33 L. Ed. 302. The ambiguity must be in the context, and not in the title, to render the latter of any avail." *U. S. v. Oregon & C. R. Co.*, 164 U. S. 526, 541, 17 Sup. Ct. 165, 41 L. Ed. 541.

The act of congress of February 26, 1900, is neither of doubtful nor ambiguous meaning, but in plain terms provides that all suits pending in any circuit court of appeals, circuit or district court of the United States, on June 27, 1898, which have been dismissed by reason of the act of congress approved June 27, 1898 [*U. S. Comp. St.* 1901, p. 752] entitled "An act to amend sections one and two of the act of March 3, 1887," shall be restored to their places in such courts and proceeded with as if the said law had not been enacted; and it further extends the time within which an appeal or writ of error may be prosecuted by the said act to six months from the passage thereof.

This act plainly includes the present suit. All the proceedings under the act of March 3, 1887 [*U. S. Comp. St.* 1901, p. 752], and amendatory acts, are permissive, and in the main intended to advise the congress. The practice thereunder is exceptional, and the judgments and decrees rendered are not executory. When such judgments and decrees are adverse to the United States and are final in the courts, the attorney general reports them to congress for such action as it sees fit to take. It seems, therefore, that it is not worth while to consider whether the act of February 26, 1900, impairs vested rights or is otherwise unconstitutional.

The motion to strike the case from the docket is overruled.

On the merits, the case is identical with that of *U. S. v. Langston*, heretofore decided by this court (29 C. C. A. 379, 85 Fed. 613), except in respect to these findings of fact, which were not in the Langston Case.

"That during said intervals the complainant was by the rules of the post office department excluded from the post office, but was under the control and direction of the postmaster to the extent that the postmaster had the right, power, and authority to summon the complainant to duty at any time during any of said intervals, and send him out again collecting or delivering mail, or assign him to any other duty within the range and line of his employment as such letter carrier. That, by reason of the said right, power, and authority of the postmaster to summon the complainant to duty at any time during any of said intervals, the complainant was prevented and prohibited from obtaining or accepting other employment during such intervals, except such employment as should be subject and second to the right, power, and authority of the postmaster to at any time so summon the complainant to duty during any and all of said intervals, and the complainant could not and did not obtain other employment."

The act under which the petitioner in this case claims extra pay distinctly grants such extra pay only in case the letter carrier is employed during the extra time for which he claims.

The facts as found by the trial judge clearly show that, during the "idle" intervals for which petitioner claims he was not employed in his duties as a letter carrier, he was not required to wear his uniform; he was not required to stay in any particular place; he was doing nothing but waiting, and waiting to be employed. The fact that during the time he was so waiting to be employed the postmaster could have summoned him to duty tends strongly to show that during such interval he was not employed, and not at all that he was employed. The fact that during the time he was so waiting he could not and did not obtain other employment may raise an equity in his favor, but in no wise proves that during the intervals for which he claims pay he was employed.

Under the finding of facts, it seems perfectly clear that during the "idle" intervals, as styled in the finding of facts, the petitioner was not employed in his duties as a letter carrier. If he was not so employed, then he has no right to recover under the statute.

For these reasons and others given in *U. S. v. Langston*, supra, the judgment of the district court is reversed, and the cause is remanded, with instructions to dismiss the suit.

MILLER et al. v. TENNANT-STIBLING SHOE CO.

(Circuit Court of Appeals, Fifth Circuit. January 13, 1903.)

No. 1,174.

1. ATTACHMENT—CLAIM BY THIRD PARTY—PROCEDURE UNDER MISSISSIPPI CODE.

Code Miss. 1892, §§ 4425-4428, provide for the filing of an affidavit of claim by a third party to property seized under execution or attachment, and that on the making of such claim "the court shall on motion of the plaintiff in execution direct an issue to be made up between the parties to try the right of property at the same term." Section 4428 provides that, if by default of the plaintiff in execution an issue be not made up at the term to which the execution is returnable, the

¶ 1. Federal courts following state practice as to issuance of attachment, see note to *O'Connell v. Reed*, 5 C. C. A. 594.

court shall discharge the claimant from his bond, and the property shall not be subject to the plaintiff's execution or attached. *Held*, that such provisions are binding on a federal court, and, where an attachment plaintiff failed to have the issue made up at the term, the claimant was entitled to have the property discharged from the levy, and to be discharged from a forthcoming bond given by him, which right was not lost by his failure to move for such discharge until after a number of terms had passed.

In Error to the Circuit Court of the United States for the Northern District of Mississippi.

The plaintiffs in error, as the claimants of certain property levied upon under writ of attachment sued out by the defendant in error, made affidavits in conformity with the provisions of section 4425 of the Mississippi Code (1892), for the trial of right of property. A portion of the property levied upon was claimed by D. W. Miller and H. J. Roper jointly, and a portion by H. J. Roper individually. For that claimed by H. J. Roper a claimant's bond was given under the statute. The writ of attachment under which this property was levied upon was returnable to the December term, 1897, of the circuit court of the United States held at Oxford, Miss. The marshal made his return on the writ December 7, 1897, and on the following day claimants filed their affidavits. The attachment issue was disposed of against the defendant in the original suit on December 7, 1899. The plaintiff in attachment never took any action toward making an issue for the trial of right of property between itself and the claimants. On December 2, 1901, the claimants filed a motion asking the court to discharge the levy under the writ of attachment and release them from their forthcoming bond, because of the failure of plaintiff to tender an issue for the trial of right of property, as required by law. The court overruled this motion, and a trial was had without any tender of issue and without an issue being joined in the case. The trial resulted in a judgment in favor of the plaintiff in attachment and against the claimants.

James Stone, C. L. Sivley, and Smith & Totten, for plaintiffs in error.

R. T. Fant, for defendant in error.

Before PARDEE and SHELBY, Circuit Judges, and MEEK, District Judge.

MEEK, District Judge, after stating the facts as above, delivered the opinion of the court.

The first error assigned complains of the action of the trial court "in overruling claimants' written motion to discharge the levy upon the property levied on under the writ of attachment, and in not pronouncing judgment for the claimants and releasing them from their forthcoming bond because of the plaintiff's failure to tender issue at the first term, as required by law." The attachment proceedings and the filing of the claimants' affidavits and bond for trial of right of property were had under the provisions of the Mississippi Code, and it is therefore incumbent upon this court to give effect to these statutory provisions, and to follow the construction placed upon them by the supreme court of Mississippi. *Bank v. Farwell*, 56 Fed. 570, 6 C. C. A. 24, 12 U. S. App. 409; *Bank v. Teal* (C. C.) 5 Fed. 503.

Section 4425 of the Code of 1892 provides the manner in which third parties may make claim of ownership to property levied on under execution, and for the bonding, holding, or disposing of prop-

erty pending the determination of the issue. Section 159 of the Code of 1892 makes these and subsequent quoted provisions of the law applicable to claimants of property levied on by virtue of writs of attachment.

Section 4427 of the Code of 1892 is as follows:

"Issue to be Made Up.—Upon the return of the execution with the affidavit and bond, if any, the court shall, on motion of the plaintiff in execution, direct an issue to be made up between the parties to try the right of property at the same term, unless good cause be shown for a continuance."

This places the burden upon the plaintiff in attachment to move the court to direct an issue to be made up, and it is for the plaintiff to tender an issue to the claimant, as the burden of proof is with the plaintiff. *McAnulty v. Bingaman*, 6 How. (Miss.) 382; *Phillips v. Cooper*, 50 Miss. 722; section 4429, Code 1892. The statute is mandatory as to the time when the issue shall be made up between the parties. It must be at the return term of the attachment. The trial of right of property may, for good cause shown, be continued, but the issue must be joined at the return term. This is made clear and emphasized by the provisions of section 4428 of the Code of 1892, which are as follows:

"Default in Making Up Issue.—If by default of the plaintiff in execution an issue for the trial of the right of property be not made up at the term to which the execution is returnable, the court shall discharge the claimant from his bond, and the property shall not thereafter be subject to execution on plaintiff's judgment; but if the claimant fail to join issue when tendered at the first term, the court, at the instance of plaintiff in execution, shall order a writ of inquiry as to the value of the property, and also to inquire whether or not the claim was made for fraudulent purposes or for purposes of delay."

This section seems clear and explicit in its terms. If at the term to which the writ of attachment is returnable the plaintiff in attachment fails to move the court to direct an issue to be made up, and fails to tender an issue to the claimant under the direction of the court, then the plaintiff in attachment is in default, and the claimant is entitled to his judgment discharging him from his bond, and the property is no longer subject to attachment. *Sears v. Gunter*, 39 Miss. 338.

In the present case the writ of attachment was returnable to the December term, 1897. This and several subsequent terms of the court passed without any action by the plaintiff in attachment looking to the making of an issue for the trial of right of property. The claimants were entitled to the judgment authorized by the statute long before it was sought by the motion interposed on December 2, 1901, but it is not apparent how their delay could operate to estop them from claiming their judgment, or how it could invest the plaintiff in attachment with any right to proceed to trial without the making up of an issue under the imperative requirements of the statute.

It is contended by counsel for the defendant in error that the issue directed by the statute need not be made up in writing; that the statute itself is silent on this point; and that no decision of the supreme court of Mississippi can be cited holding that it must be made in writing. In *Smokey v. Wack*, 57 Miss. 833, the sufficiency of

the averments in a tender of issue filed by a plaintiff in attachment are passed upon. The statement of this case by the court precludes the possibility of the tender of issue having been other than a formal plea and in writing. Besides, it is plainly deducible from the Code of 1892 that the issue shall be made up in writing. Section 670 provides that the filing of the declaration shall be considered the commencement of an action. Section 671 is entitled "Of Pleading; the Declaration," and sets forth what the declaration shall contain. Section 681 makes all provisions relating to the declaration extend to all subsequent pleadings, so far as they may be applicable. Lastly, section 702 provides that pleadings shall be signed by the party or his attorney. However, in this case the record does not disclose that the plaintiff in attachment tendered an issue either orally or in writing, and it therefore could not be held to have complied with the law in any event.

In view of the holding on the first error assigned, and its necessary effect on the disposition of the case, it is not deemed material to discuss other questions raised.

For the error indicated the judgment of the circuit court is reversed, and the case is remanded for further proceedings.

WHITE v. THOMPSON et al.

(Circuit Court of Appeals, Fifth Circuit. January 20, 1903.)

No. 1,165.

1. BANKRUPTCY—PRIOR LEVY—INJUNCTION—JURISDICTION.

Where a levy is made under an execution issued out of a state court prior to the adjudicated bankruptcy of the judgment debtor, the referee cannot issue injunction to restrain such proceedings to enforce the judgment.

2. SAME—EXEMPTION—APPEAL—EQUITABLE ORDER.

A levy was made under an execution of a state court, prior to the adjudicated bankruptcy of the debtor. Upon being erroneously enjoined by the referee from further proceedings to enforce the judgment, the property was released from levy, and brought into the bankruptcy proceedings, and the creditors in the state court whose claims were not dischargeable in bankruptcy filed their claims before the referee, but declined to waive any rights arising under the judgment, or to recognize the jurisdiction of the bankruptcy court over their claims. The referee denied the debtor his exemption as against the judgment, and the bankruptcy court affirmed the decision. Pending an appeal to the circuit court of appeals, the bankrupt was discharged. *Held*, that the appeal could be best disposed of by dissolving the injunction, reversing the judgment of the bankruptcy court, and remanding the case, with orders to allow the exemption as to all debts discharged by the bankruptcy, thus leaving the state court to determine the exemption as against the judgment.

Petition for Revision of Proceedings of the District Court of the United States for the Northern District of Alabama, in Bankruptcy.

¶ 2. Appeal and review in bankruptcy cases, see note to *In re Eggert*, 43 C. C. A. 9.

On July 3, 1901, the petitioner, Henry K. White, was duly adjudged a bankrupt, and on the same day he filed before the referee a petition reciting as follows: "That one J. L. Thompson, who is scheduled as a creditor of your petitioner and whose debt is provable under the bankrupt act against his estate, did, on the 21st day of June, 1901, cause a writ of execution to issue out of the court of probate, Jefferson county, and did cause the same to be placed in the hands of the sheriff of Jefferson county, with instructions to levy same on all the personal property of petitioner, which petitioner has claimed as exempt, which execution was levied on said 2d day of July,"—on which petition the bankrupt prayed that the said J. L. Thompson be required by order of the court to dismiss said execution proceedings, and propound in the bankruptcy court any claim which he may have against the petitioner. On this petition, the referee issued a rule nisi, to which Thompson answered as follows: "That in, to wit, the year 1892, said bankrupt filed his petition in the probate court of Jefferson county, Alabama, praying that letters of administration de bonis non be issued to him out of said court on the estate of Samuel Thompson, deceased, the father of said J. L. Thompson. That upon the consideration of said petition by the judge of said probate court the same was granted, and the said H. K. White thereupon made the bond required, and letters of admission de bonis non were accordingly issued to him, and he entered upon the administration of said estate. That during the course of said administration, and within a few months after his said appointment, the said H. K. White, as such administrator de bonis non, received and collected in cash a large sum of money, to wit, about \$1,800 or \$1,900, as the property of said estate of said Samuel Thompson, deceased. That in the year 1900 the said H. K. White was cited to file his account and vouchers as such administrator de bonis non for final settlement of said estate, and thereupon said final settlement was made. That on March 6, 1900, the date of said final settlement, the said probate court rendered a judgment against said H. K. White as such administrator de bonis non and individually in favor of J. L. Thompson, Miller Thompson, and Wm. Leslie, as administrator of the estate of Mary Thompson, deceased, each separately and severally, for the sum of \$153.26½, besides judgment for costs, \$40.55. That each of said judgments contained a waiver of exemption clause as to personal property, and as against said judgments no exemption of personal property was allowed. That on April 7, 1900, said J. L. Thompson had an execution issued on the judgment in his favor, and placed the same in the hands of the sheriff of Jefferson county, Alabama. That again, on November 11, 1900, another execution was issued on said judgment, and placed in the hands of the said sheriff. That again, on June 21, 1901, another execution was issued on said judgment in favor of said J. D. Thompson, and on said date the same was placed in the hands of A. W. Burgin, sheriff of Jefferson county, Alabama. That on, to wit, July 1, 1901, prior to the adjudication in this cause, the said execution writ was by said sheriff executed by levying on the personal property of said bankrupt complained of in his said petition. Said J. L. Thompson avers that the judgment against said bankrupt in his favor, upon which said execution was issued, is not such a debt or judgment as can be affected by the bankruptcy act, but comes within the exception of subdivision 4 of section 17 of said bankruptcy act, approved July 1, 1898 [U. S. Comp. St. 1901, p. 3428], and was rendered more than one year prior to the adjudication herein, and that the lien of said execution is not and cannot be affected by the adjudication of said bankrupt. Wherefore said J. L. Thompson prays your honor that the said petition filed July 3d by said bankrupt be not allowed, and that the same be dismissed out of this court, and for such other, further, and general relief as the averments and proof herein may warrant; and will ever pray, and," etc. To this answer the bankrupt, White, filed a lengthy replication, setting forth in detail how it happened that he was in default as an administrator, and certain propositions made by him to Thompson, and the refusal of the same; whereupon the referee, on hearing, enjoined the further proceedings to enforce the judgment in the probate court of Jefferson county, and ordered a dismissal of the same, and directed said Thompson to propound in the bankruptcy court his claim against the

bankrupt. Thereupon J. L. Thompson, Miller Thompson, and William Leslie, administrator of Mary Thompson, deceased, each made proof of their claim, as evidenced by the judgment rendered in the probate court of Jefferson county, but distinctly denied that their claims were dischargeable in bankruptcy, and declined to waive any rights arising under such judgments, or to recognize the jurisdiction of the bankrupt court over such claims. Following proof of these claims the trustee, on petition of the bankrupt, designated and set apart certain movable property of the value of \$450 and necessary and proper wearing apparel for the bankrupt and his family, and all family portraits or pictures, as property exempt under the laws of Alabama. To this action of the trustee said J. L. Thompson filed exceptions and objections as follows: "(1) That the said bankrupt is not entitled to claim personal property as exempt to him under the constitution and laws of the state of Alabama as against their said judgments, for the reason that said judgments were rendered on the final settlement of said bankrupt as administrator de bonis non of the estate of Samuel Thompson, deceased, as being their respective distributive shares in the estate of Samuel Thompson, deceased, and is not such a debt as against which a claim of exemption to personal property can be interposed and sustained. (2) That the said bankrupt cannot claim his exemption against their said judgments rendered against him, as said judgments are not based on, nor do they arise by virtue of, any contract made by or with said bankrupt, but were rendered as their distributive shares in the estate of Samuel Thompson, deceased, by the probate court of Jefferson county. (3) That the said decrees or judgments are against said bankrupt as administrator de bonis non of the estate of Samuel Thompson, deceased, and that he had at the time of the rendition of said judgments sufficient assets in his hands with which to pay the same, which he unlawfully withheld or had wasted, and there is no real or personal property of said estate upon which execution can be levied." On these exceptions and objections the referee disallowed the exemptions, and on review in the bankruptcy court the referee's action was affirmed. Thereupon the matter was brought before this court by petition for review. Since the case has been here pending, the bankrupt has prosecuted his application for a discharge, and has been awarded the same in the usual form.

A. Latady, for petitioner.

Felix E. Blackburn, for respondents.

Before PARDEE and SHELBY, Circuit Judges.

PER CURIAM. The injunction issued by the referee restraining proceedings in the probate court of Jefferson county in the disposition of property therein duly levied upon prior to the adjudication in bankruptcy was unwarranted. For the last authoritatively adjudicated case on the subject, see *Metcalf Bros. & Co. v. Barker* (decided in Sup. Ct. U. S., Dec. 1, 1902) 23 Sup. Ct. 67, 47 L. Ed. —. However, as the property under execution and levy in the probate court of Jefferson county was released and brought into the bankruptcy, it would seem that therefrom, except as against the bankrupt's creditors whose debts are not dischargeable in bankruptcy, the bankrupt would be entitled to the exemptions allowed by the laws of the state of Alabama. As the case shows that the bankrupt has been discharged from all debts except such as are by law excepted from the operation of a discharge in bankruptcy, we may well dispose of this petition for review by dissolving the injunction restraining the said J. L. Thompson and his coheirs from further proceeding in the probate court of Jefferson county, Ala., to enforce their claims on the judgment therein rendered reversing the judgment of the bankruptcy court, which denies the exemptions, and remanding the case, with directions to enter a judgment

allowing the exemptions as set aside by the trustee as against all creditors whose debts are discharged by the bankruptcy. This will leave the question of the bankrupt's right of exemption as against the judgment in favor of Thompson et al. to be decided in the probate court of Jefferson county, Ala., where it properly belongs; and it is so ordered. The costs of this court to be paid by the petitioner.

DICKINSON et al. v. CONSOLIDATED TRACTION CO. et al.

(Circuit Court of Appeals, Third Circuit. January 29, 1903.)

No. 30.

1. CORPORATIONS—LEASE OF PROPERTY AND FRANCHISES—ANNULMENT AT SUIT OF MINORITY STOCKHOLDERS.

A court of equity will not, at a suit of a minority stockholder, annul a lease made by the corporation of its property and franchises, where such lease was approved by a large majority of the stockholders, and is not shown to have been induced by fraud, nor even to be detrimental to the interests of the corporation.

2. SAME—POWER TO MAKE LEASE—NEW JERSEY STATUTES.

Under the statutes of New Jersey which authorize a corporation to lease its property and franchises, or to take a lease of the property and franchises of another corporation,—no limitation being placed upon the term of such leases,—the fact that such a lease between two corporations of the state is for so long a term as to amount practically to a conveyance of the property in fee does not affect the power of the one corporation to make, or of the other to accept, it.

Appeal from the Circuit Court of the United States for the District of New Jersey.

Chas. J. Roe, for appellants.

John G. Johnson, for appellees.

Before ACHESON and DALLAS, Circuit Judges, and ARCHBALD, District Judge.

DALLAS, Circuit Judge. It is unnecessary to determine whether the amendments by which the complainants proposed to conform their bill to the requirements of rule 94 should not have been allowed, for, if they had been, the final decision would not have been different. The decree dismissing the bill went to the merits of the case, and, upon the merits, was clearly right. The suit was brought by the holders of 100 shares of the capital stock of the Consolidated Traction Company to annul a lease of its franchises and property, which had been made to the North Jersey Street Railway Company. This transaction of leasing was consummated about 18 months prior to the bringing of the suit. It was approved by all the shareholders of the lessor company, excepting only the holders of 400 shares; and this almost unanimous judgment of those in interest, time and the event have fully vindicated, for there can be no doubt that, by the action taken in pursuance of it, the corporation itself, and therefore all its shareholders, have been benefited. Yet these complainants prayed the court below to undo what had thus been done, and

now insist that, in refusing to grant that prayer, it denied them relief to which in equity they were entitled. The grounds upon which this insistence has been rested are untenable. The allegation that the lease in question was made in fraud of the traction company, and of the rights of its nonassenting shareholders, was not supported by the proofs; and, in our opinion, neither of the corporations concerned exceeded its lawful power in respectively making and taking that lease.

Fraud is not to be presumed, but must be established by evidence of facts from which, at least, its existence may with reasonable certainty be inferred; and the record before us reveals nothing which would have justified a finding that any of the defendants, in promoting and effecting this lease, were actuated by any purpose other than that of subserving the interest of the traction company. Having independently considered the evidence, we adopt the statement of its effect which is contained in the opinion of the court below; and we concur in the conclusion which was there reached,—that the “state of things as disclosed by the record is very far from sustaining the allegations of fraud against the individual defendants in this case, directors in the two companies, or any of them.”

These companies were both New Jersey corporations, and by the law of that state, conflicting neither with its constitution nor with that of the United States, each of them was clearly authorized either to make or to take a lease of the property and franchises of the other. This, too, has been so convincingly shown by the learned circuit judge that any further discussion of the subject would be superfluous. The suggestion that, “for all substantial and practical purposes, a lease for 999 years is a conveyance in fee,” is without force. The question is not as to what may be the practical effect of the particular instrument, but as to its authorization; and, as corporation leases for 999 years were well known when, by the statutory provisions to which we have referred, the power to lease was broadly and unqualifiedly given, we are not at liberty to assume that the exercise of that power was intended to be restricted to leases for a term not to exceed some limited, but wholly undefined and indeterminate, period.

The judgment of the circuit court is affirmed.

GREEN v. FITCHBURG R. CO.

(Circuit Court of Appeals, First Circuit. January 22, 1903.)

No. 457.

1. BILL OF EXCEPTIONS—FEDERAL PRACTICE.

The settlement of a bill of exceptions in a federal court is governed by the federal statutes and practice, and not by the statutes or practice of the states.

¶ 1. Conformity of practice in federal courts in common-law actions to that of state courts, see notes to *O'Connell v. Reed*, 5 C. C. A. 594; *Insurance Co. v. Hall*, 27 C. C. A. 392.

See Courts, vol. 13, Cent. Dig. § 937.

See (C. C.) 116 Fed. 928.

Daniel L. Smith, for petitioner.

Robert J. Fisher, for respondent.

Before COLT, Circuit Judge, and ALDRICH and BROWN, District Judges.

PER CURIAM. This is not a petition for a writ of mandamus, but a petition to establish a bill of exceptions under the state practice of Massachusetts. Rev. Laws Mass. c. 173, § 110.

It has been uniformly held by the federal courts that the settlement of bills of exceptions is governed by the federal statutes and the practice of the federal courts, and not by the practice of the several states. The question is reviewed by this court in the case of Railroad Co. v. Hyde, 5 C. C. A. 461, 56 Fed. 188.

Under this well-settled rule, we have no power to entertain a petition of this character.

The petition is dismissed, with costs for the Fitchburg Railroad Company.

HALLETT v. NEW ENGLAND ROLLER GRATE CO. et al.

(Circuit Court of Appeals, First Circuit. January 7, 1903.)

No. 376.

1. ACTION FOR MONEY PAID—LACHES AS DEFENSE.

In an action at law for money had and received, to recover a sum paid in a transaction which was void, where limitation is not pleaded as a defense the court is not authorized to direct a verdict for defendant on the ground that there was unreasonable delay in bringing the suit.

In Error to the Circuit Court of the United States for the District of Massachusetts.

For opinion below, see 105 Fed. 217.

Fred. H. Williams (Frank M. Copeland, on the brief), for plaintiff in error.

Walter C. Harriman (Isaiah R. Clark, on the brief), for defendants in error.

Before COLT, Circuit Judge, and ALDRICH and BROWN, District Judges.

PER CURIAM. This was an action for money had and received, wherein the plaintiff sought to recover the sum of \$3,000 paid by him upon a transaction which was void under the provisions of the Public Statutes of New Hampshire. There was no plea of the statute of limitations, and therefore there was, in our opinion, no question of unreasonable delay in bringing suit. The circuit court, therefore, erred in directing a verdict for the defendant upon the ground of unreasonable delay.

The judgment of the circuit court is reversed, with costs to the plaintiff in error.

¶ 1. See Limitation of Actions, vol. 33, Cent. Dig. § 678.

WESTINGHOUSE AIR BRAKE CO. v. NEW YORK AIR BRAKE CO.

(Circuit Court of Appeals, Second Circuit. December 16, 1902.)

No. 33.

1. PATENTS—CONSTRUCTION OF CLAIMS.

When the language of a claim of a patent is clear and distinct, the patentee cannot claim anything beyond for the purpose of establishing infringement.

2. SAME—INFRINGEMENT—EQUIVALENTS.

The combination of an alleged infringing device is not that of the patent merely because it will do the same work in one of the several operations it is designed to effect in substantially the same way, and it does not infringe where it is not only structurally different, but performs the other operations in a substantially different way.

3. SAME—ENGINEER'S VALVE FOR CONTROLLING AIR BRAKES.

The Westinghouse & Moore patent, No. 401,916, for an improved engineer's brake valve, designed to provide for such gradual opening and closure of the valve which controls the discharge of air from the brake pipe as to cause a substantial equalization of pressure in such pipe and the uniform application of the brakes throughout the length of the train in making service stops, is in no sense a pioneer patent, but, in view of the prior art, must be limited to the precise construction shown, or its equivalent. Claims 4 and 8 construed, and held not infringed by the valve of the Vaughan & McKee patent, No. 504,290.

Appeal from the Circuit Court of the United States for the Northern District of New York.

Charles Neave and Frederick P. Fish, for appellant.

George H. Christy and Frederick H. Betts, for appellee.

Before WALLACE, LACOMBE, and TOWNSEND, Circuit Judges.

TOWNSEND, Circuit Judge. This cause comes here upon an appeal of the defendant in the court below from a decree of the United States circuit court for the Northern district of New York sustaining claims 4 and 8 of patent No. 401,916, granted April 23, 1899, to George Westinghouse, Jr., and Frank Moore, for an engineer's brake valve. The railway automatic quick-action brake system with which this engineer's brake valve is connected has been fully discussed in prior decisions in this court. (C. C.) 59 Fed. 581; 11 C. C. A. 528, 63 Fed. 962; (C. C.) 65 Fed. 99; 16 C. C. A. 371, 69 Fed. 715; (C. C.) 77 Fed. 616; (C. C.) 112 Fed. 424. In this system the brakes on the train are released and held in their normal or running condition by means of fluid pressure, communicated from a main reservoir to the train pipe. An engineer's brake valve is mounted on the cab of the locomotive engine, and controls the passage of air between the main reservoir on the locomotive and the train pipe and triple-valve appliances throughout the train. The earlier engineer's brake valves were equipped with what was known as a "three-way cock." Patent No. 259,710, granted to N. J. Paradise in 1882, covers such a cock in connection with a spring valve for maintaining an excess of pressure in the main reservoir over that in the train pipe. In this device, when the engineer wished to release the brakes, he threw the handle of the cock

back to the extreme limit of its movement in one direction. This served to establish an unobstructed passage between the main reservoir and the train pipe, and the air rushing from the main reservoir into the train pipe charged it and its auxiliary reservoirs with compressed air, and released the brakes from the cars. When the required running pressure had been secured, the engineer, by a short forward movement of the handle, closed said direct passage, and opened an unobstructed passage through said excess pressure spring valve, which was so graduated as to compensate for train-pipe leakage, and allow the requisite amount of main-reservoir pressure to always feed through it, and keep the brakes in what is known as "running position." When the engineer wished to slow down or stop, he moved the valve handle still further forward, so as to close communication between the main reservoir and the train pipe, and to open the train pipe to the atmosphere, and permit escape to the air. This was known as the "service position" of the brakes. As soon, however, as the engineer thought that the train-pipe pressure had been sufficiently reduced by the resultant brake application, he moved the handle back a short distance, so as to close all the ports, and hold the brakes at the point at which they had already been set. This position was known as "lap position." When the engineer desired to make a quick application of the brakes, he moved the handle to the extreme limit of its forward travel, and this opened the train-pipe discharge passage to the atmosphere, causing a quick application of the brakes. This was known as "emergency position." That this three-way cock was practicable by the exercise of due care is shown by the testimony of Mr. H. Herman Westinghouse, one of complainant's witnesses, to the effect that his brother, one of the patentees herein, when descending a grade on an experimental 50-car train, and after the engineer had failed to properly apply the brakes "operated the engineer's valve in a way that effected a moderate and complete reduction throughout the entire train resulting in the setting of every brake, thereby causing a very material decrease in the speed. This gave an opportunity for releasing and restoring pressure to the reservoirs for further applications, so that the descent was conducted with entire safety, and at a very moderate rate of speed." Thus, in this device, the engineer, by moving the handle of the cock, was able to so vary the connections between the main reservoir and train pipe and the outer atmosphere as positively and directly to control the operation of the brakes, and to put them either in release, service, lap, or emergency positions. But the operation of this cock on long trains was attended with serious difficulties, especially in slowing down, or making of service or station stops. These difficulties arose from the fact that, when the engineer wished to slow down or make a service stop, he must open the valve for a short distance only, let out a comparatively small amount of air, and close the valve again. As a result of this action, the reduction of train-pipe pressure first became effective at the forward end of the train pipe, causing an application of the brakes in the forward cars, and thereafter the air surging or rushing forward from the rear portion of the train, and being unable to escape, accumulated in the forward end of the train pipes, and by reason of its momentum raised the pressure there,

thus releasing the forward brakes. In these circumstances the train was likely to be pulled in two, with serious resultant damage. As stated by counsel for complainant, the new problem was "to secure, in ordinary or 'service' stops with long trains, an approximately uniform reduction of train-pipe pressure throughout the length of the train pipe, so that there will be no release of brakes at the front end of the train, due to the forward surging of an appreciable excess of pressure over what then existed at the other end." It was found to be impracticable to rely upon the judgment of the engineer to so manipulate the valve that it would accommodate itself to the pressure of the surging air, varying by reason of differences in the speed and length of trains. It was, therefore, necessary, in slowing down or making service stops, to provide for an automatic slow closing of the engineer's valve after the requisite amount of air had been discharged. That the patent in suit covers a means for accomplishing this object which is practical and successful, is proved. But defendant contends that the objections referred to were also obviated by the prior valves known as "B12" and "C7" engineer's valves, made and sold by the Westinghouse Company, and that C7 was a practical valve, and embodied all the essential elements of the patent in suit. It is only necessary to consider the C7 valve, which was the later and simpler of the two. The evidence as to its commercial success is conflicting and inconclusive. During the years 1887 and 1888 complainant sold 2,116 of said valves, of which more than one-half were returned. It was operative, however, when in proper condition, was successfully used, with slight modifications, by complainant, on an exhibition train of 50 cars, and was in practical use on railway trains for nearly 10 years. Defendant's expert admits that its practical operation was subject to certain disturbing influences, and that "the remedy for obviating or preventing such disturbing influences to a sufficient extent was embodied in the valve of the patent in suit."

The objects of the invention of the patent in suit, as stated in the specification, were as follows:

"Primarily, to provide for such gradual opening and closure of the valve which controls the discharge of air from the brake pipe as to cause a substantial equalization of pressure in the brake pipe and uniform application of the brakes throughout the length of the train, and obviate the liability to release the brakes on the forward cars in long trains, which has heretofore been found to be induced by an inequality of pressure in the brake pipe, occasioned by the quick release of a considerable quantity of air and the sudden closure of the discharge valve thereafter, and from which the breaking of the train into two or more sections has sometimes resulted. A further object of our invention is to effect a simplification of structure, and prevent the access to the valve-operating piston of grease or other foreign matter tending to clog or interfere with its free and normal movements."

Claims 4 and 8 are as follows:

"(4) In an engineer's brake valve, the combination of a valve casing or chamber; a main air-reservoir connection and a brake-pipe connection leading thereinto; a direct supply port formed in a valve seat in the chamber, and adapted to establish direct communication between said connections; a movable abutment fitted to work in a chamber in the casing, communicating on one side of the abutment with the brake-pipe connection; a discharge valve connected to said abutment, and controlling a passage from the brake-pipe connection to the atmosphere; an equalizing supply port leading from the

abutment chamber to the valve seat on the side of the abutment opposite to that which is open to the brake-pipe connection; and a regulating valve working on the valve seat, and controlling the direct supply and equalizing ports, substantially as set forth."

"(8) In an engineer's brake valve, the combination of a valve casing or chamber; a main air-reservoir connection and a brake-pipe connection leading thereinto; a direct supply port formed in a valve seat in the chamber, and adapted to establish direct communication between said connections; a direct exhaust passage leading from the valve seat to the atmosphere; a discharge valve controlling an independent exhaust passage from the brake-pipe connection; a movable abutment connected to the discharge valve; and a regulating valve controlling ports by which, respectively, an equilibrium of pressure is established, and a difference of pressure is effected on opposite sides of the abutment, and also controlling communication between the direct supply port and the brake-pipe connection and between the brake connection and the direct exhaust passage, substantially as set forth."

The C7 Equalizing Valve—Service Position.

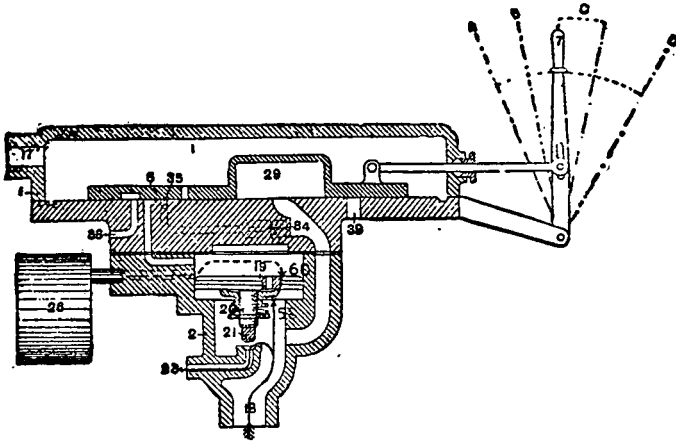

The Valve of the Patent—Service Position.

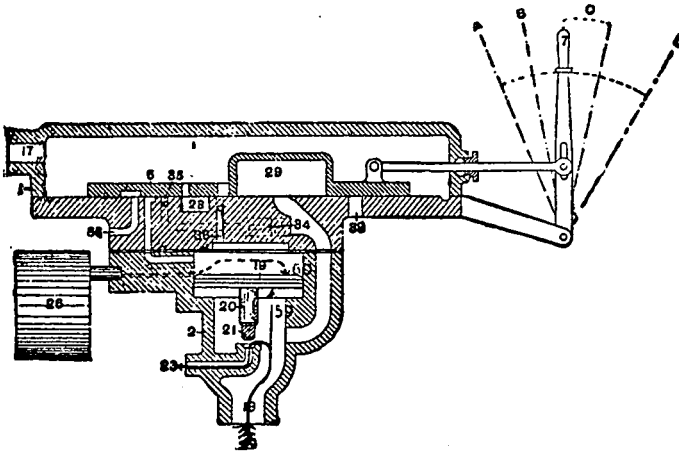

The above drawings illustrate the construction and operation of the C7 valve and of the patent in suit. They employ the same general combination of air ducts, ports, and controlling devices to do the work required of an engineer's valve to effect the several brake operations already referred to. In each there is a regulating valve chamber, 1, and regulating valve, 5, governing the several ports in the valve seat. Each is provided with the main-reservoir connection, 17, and the train-pipe connection, 18, through which compressed air passes from the main reservoir through said chamber and valve to the brake pipe throughout the train. Each has the small service discharge passage from the brake pipe, 23, separate from and independent of the large emergency discharge passage, 29-39. Each has the service discharge valve, 21, which closes the service discharge passage, 23, and a movable abutment or piston, 19, connected with said discharge valve, which slowly and automatically closes said valve 21. Each has a supplemental reservoir, 26, and the exhaust port, 38, leading to the atmosphere from the upper or supplemental reservoir side of the piston, 19. Each has a passage, 32, shown, but not numbered. The three essential differences between the two devices are the following: The C7 valve has a perforated valvular abutment or piston, 19, while said valve in the patent in suit is imperforate. The passage from the main reservoir to the train pipe in C7 is intercepted by the perforated valve, 19, through which the compressed air must pass in order to reach the train pipe. In the patent in suit the passage from the main reservoir to the train pipe is a direct one around the abutment chamber, and is not intercepted by a valve. There are two equalizing ports, 36 and 32, through which air is admitted to the top of the abutment. The port 36 is not found in the C7 valve. The C7 device employed a spring to keep the valve, 20, on its seat. The patent in suit dispensed with this spring, and by means of said port 36, in connection with other ports, provided an equilibrium of air pressure on the abutment, 19. The result of these changes was to accomplish what is stated in the specification of the patent in suit to be the "further object" of the invention, namely, "to effect a simplification of structure and prevent the access to the valve-operating piston of grease or other foreign matter tending to clog or interfere with its free and normal movements." It consisted in dispensing with the perforated piston of the C7 valve by employing an air duct leading directly from the main reservoir to the lower side of the piston, instead of leading through the piston; thus simplifying the structure. Pistons without perforations were old in fluid pressure devices, and the invention of the patent consists in such a reorganization of the C7 valve as to bring the other appliances into co-operative relations with such a piston, and enable the apparatus to do its work in the several brake applications, which it must be able to effect in order to accomplish what is stated to be, primarily, the object of the invention.

The patent in suit, therefore, is in no sense a pioneer patent. What is stated in the specification to be primarily the object of the invention had previously been accomplished. The object of the invention had been accomplished by the careful use of the old three-way cock, and it had been accomplished by the prior C7 valve, and practically as

efficiently, when that valve was in perfect working order. The defendant was at liberty to embody any arrangement of air ducts, ports, and controlling devices to do this work, except the combination of the patent, or equivalent parts so constructed and arranged as to do their work in substantially the same way as those of the patent. The "substantial equalization of pressure" thus utilized to balance and control a piston had been previously covered by George Westinghouse, one of the patentees herein, in prior patents granted to him for improvements in fluid-pressure brake mechanism, as will appear by reference to prior decisions between these parties (C. C.) 59 Fed. 581; 11 C. C. A. 528, 63 Fed. 962.

Defendant's Valve—Service Position.

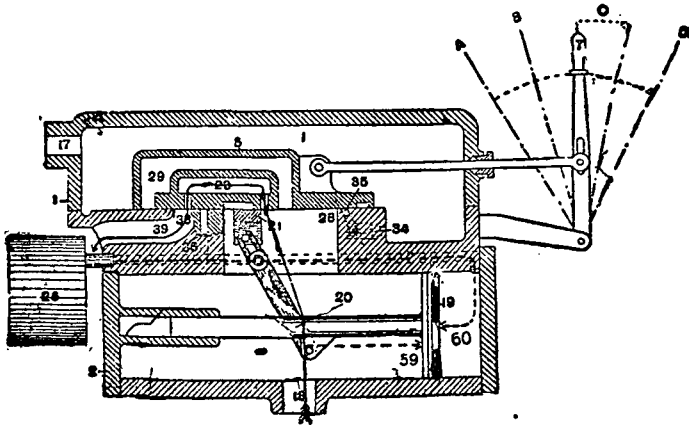

The defendant's engineer's valve device shown in above drawing is constructed under patent No. 504,290, granted August 29, 1893, to Vaughan & McKee. In certain minor and immaterial details of construction it differs from the valves of C7 and the patent in suit. Thus it has a main slide valve and horizontally moving piston, while complainant uses a rotary valve and poppet piston. In common with them it comprises valves, passages, ports, and a piston for regulating the operation of brakes. It has a "direct supply port, 28, formed in the valve-seat" of the patent in suit, not found in C7, through which the air passes from the main reservoir to the train pipe. This improvement of the patent in suit involved invention, and defendant's construction is its equivalent. The valve, 21, is connected by a pivoted lever with the stem, 20, of the piston, 19. The air chamber on the left of said piston communicates with the train pipe at 18. On the right of said piston it communicates with supplemental reservoir, 26. The radical differences in the principle, organization, and operation of the two structures will be best understood by a comparison of the differences in their operation. In release position in each device the handle, 7, is fixed at A, and a direct passage is opened through the port, 28, formed in the valve seat between main reservoir and train pipe. In the patented device air is admitted also to the top of the piston through pass-

ages, 31 and 32 (shown, but not numbered), in order to hold the discharge valve, 21, to its seat, and keep the discharge passage, 28, closed against the escape of air. In defendant's device in this position the discharge valve, 21, does not close the discharge passage, 23. It is closed by the seat of the main valve. In defendant's device air is being discharged from supplemental reservoir, 26, through ports 36 and 38, to the atmosphere. In order to pass the running position in each device the handle, 7, is moved to B. This movement brings the main valve, 5, across the port 28, and cuts off direct communication between main reservoir and train pipe, and valve 5 opens said communication through certain smaller passages, not numbered, and not necessary to be here considered, one of which is intercepted by a check valve, and thereby establishes an equilibrium of air pressure on opposite sides of the piston, 19. By this operation the brakes are kept in running position, as in the three-way cock and C7 devices. In the patented device in this position air pressure above the piston, 19, must hold the valve 21 to its seat in order to keep passage 23 closed. In defendant's device the passage 23 is closed at the extreme left by the main valve seat. That valve 21 covers it on the right is, therefore, practically immaterial. In order to make a service application in complainant's device, the handle, 7, is first moved to the further side of the two positions shown at C. Thereby main valve, 5, opens an exhaust, 38, through port 32, shown at the right of 38, but not numbered, above the piston, 19, to the atmosphere; the excess of pressure below the piston, thus induced, causing valve 21 to rise from its seat and open the discharge passage 23, and permit air to pass from the train pipe to the atmosphere. When the engineer thinks that the reduction of pressure above the piston and in the supplemental reservoir required to make the suitable brake application has been accomplished, he moves the handle back to the nearer or left position shown at C, known as the "lap position," thereby closing the exhaust, 38. The valve 21 is then slowly and automatically forced back on its seat as a result of the gradually diminishing brake-pipe pressure below and the gradually increasing reservoir pressure above the piston, 19. This combination of forward movement to "service" and backward movement to "lap" was characteristic of the C7 device. Defendant does not and cannot employ this combination movement. In its device the engineer, in order to make a service application, moves the handle to one of several notches indicated on a dial graduated to provide for varying requirements of service, and leaves it there. This positive movement of the main valve, 5, directly opens the train pipe to the atmosphere through exhaust 38, and closes the port 36. As a result of this positive movement, the air, passes out from the train pipe and the chamber on the left of the piston, 19, through 38, and the excess of pressure of the air passing from the supplemental reservoir into the chamber on the right of the piston gradually moves it towards the left. The lever connecting the piston and valve 21 being thus moved, causes valve 21 to move toward the right until, as the pressure on the left of the piston continues to decrease, the valve closes said train-pipe discharge passage. Valve 21 does not open the train-pipe discharge pass-

age. It is unnecessary to discuss the operation of the devices in emergency applications.

The problem presented was to provide such an improvement of the three-way cock and C7 devices, which were practicable when skillfully handled, that it could be operated by the ordinary engineer. The inventors of the device in suit solved the problem by an organization which trusted the judgment of the engineer in making forward and subsequent backward movements of the main valve for service applications. The result of this movement was to create and disturb equilibriums of pressure which caused both a gradual opening and gradual closing of a discharge passage by means of a discharge valve. The operation of this discharge valve is essential to every operation of the patented device. Its whole mechanism is designed to secure equilibrium of pressure, and to keep the valve on its seat in the release and running positions. Its characteristic feature is indirect operation accomplished by reliance on air pressure. In defendant's device the engineer is only trusted to exercise his judgment to select one of several service graduations to which he shall move the handle of his main valve. Said movement does not depend on any equilibrium of air pressure to gradually open and close a discharge valve, but it positively and directly opens a discharge passage. Defendant's discharge valve never opens any passage and never closes any passage except in service position. When defendant's device is in release position, any air which may be on the right side of the piston is passing out, so that the piston may be in its normal position, and ready to work. Air pressure does not hold the valve to its seat, because the air is passing out without affecting its position. The characteristic feature of defendant's device is direct, positive operation, accomplished by a direct movement of the main regulating valve. There are radical differences, therefore, between the patented device and that of defendant in theory, object, organization, and operation.

In view of the prior art, the complainant must be limited to the precise construction patented by him or its equivalent. The question is whether defendant employs the controlling devices of the patent. The piston and discharge valves are elements of the claims in controversy. The piston and discharge valve of the patent is an integral structure, and the valve is carried on a stem of the piston to and from a passage leading from the train-pipe exhaust connection to the atmosphere, and opens and closes that passage. The passage must always be opened or closed, and must be opened and closed at exactly the appropriate moment in an application of the brakes, and it is opened and closed only by the valve; consequently, the piston and valve are always doing this work of opening or closing the passage. The piston is the piston of the C7 valve minus the perforations, and the discharge valve is that of the C7 valve. This valve does its work at the same place and in the same way, being actuated by air pressure upon the piston. There is no similarity in structure and details of arrangement between the piston and valve of the defendant's device and those of the patent, and, if it embodies them, it is because valve 21 and piston 19, are so constructed and arranged in relation to one another and

the other parts of the combination that they are equivalents of those devices in the patent. In the defendant's apparatus the discharge valve is not integral with the piston, or connected to any abutment, but is actuated by the lever connected with the piston. The valve, when in its normal position, does not close the train-pipe exhaust passage, and cannot open that passage. Both of these things are done by the main slide valve, 5. When the passage is opened by the main slide valve, valve 21 may move so as to cover the passage; but said passage is so closed in release and running positions not because of the presence of the valve, but because the end of the passage 23 has come over the center of the main slide valve. The passage is opened directly by the main valve, and not by any discharge valve carried by the piston, and it is thereafter closed by the movement of the piston, which takes up a series of new positions, stopping automatically at predetermined positions for brake applications. In the apparatus of the patent the valve 21 controls both the opening and the closing of the train-pipe discharge passage, and insures a slow and gradual opening as well as a slow and gradual closing of that passage. One of the stated objects of the patent is to provide for "gradual opening." In the defendant's apparatus there is no provision by means of which the piston may, in any case, effect a slow opening of this passage, but the passage is opened by the direct movement of the valve handle, and not by any movement of any valve controlled by the piston. In the release application of the brakes, defendant's piston, 19, and its valve 21 do not in any way control any passage whatever; nor do they in the running application. In the service application they do. The fourth claim covers, inter alia, "an equalizing supply port leading from the abutment chamber to the valve seat on the side of the abutment opposite to that which is open to the brake-pipe connection." Two ports are shown in the drawing, to either of which this description might apply, the ports 32 and 36. Such an equalizing port was not necessary in the C7 device, because there the air charged into the train pipe first passed into the chamber above the perforated piston, and the discharge valve was kept seated by the preponderance of pressure above the piston. But by reason of the "direct passage" improvement of the patent in suit upon C7, the air would have passed through the direct supply port, 28, to the lower side of the piston, 19, and would have raised the valve 21 from its seat, so as to allow the escape of air, and prevent the operation of the device, as already explained, unless an equalizing port were provided leading to the upper side of the piston to counterbalance the pressure below and keep the discharge valve on its seat. The location of this equalizing port is shown by the following description of the release position in the specification:

"A direct passage is thus afforded for air from the main reservoir to the brake pipe to effect the release of the brakes and the succeeding recharging of the auxiliary reservoirs. At the same time communication is established, through a smaller port, 31, in the valve, and an equalizing supply-port, 32, in the valve-seat, between the main air-reservoir and the chamber 24, above the piston and connected supplementary chamber, 26, equilibrium of pressure in the chamber above and below the piston being thereby established and the discharge valve held to its seat."

And its function is shown in the foregoing and following further description in the specification of the release position where communication is established:

"Between the main air reservoir and the chamber above the piston, in order to charge said chamber and its connected supplemental chamber with air at a pressure equal to that in the brake pipe, and thereby to institute an equilibrium of pressure on both sides of the piston, and hold the discharge valve to its seat."

The defendant has no such port, and its device performs no such function. The defendant's device is provided with a single port, marked 36 in the drawings, which it is contended infringes the complainant's port 36. As to this port defendant's expert makes the following admission:

"Said passage, H [36] in defendant's valve in the running position does serve to maintain an equality in pressure between the train pipe and the small reservoir, 155 [26], by affording direct communication between them; and, so far as its relation to said elements, train pipe and small reservoir, is concerned, I should regard it as the equivalent for the second equalizing port, 36, of the patent in suit, in its relation to the train-pipe and supplemental reservoir."

This port also permits at the same time—that is, in running position—free communication between the supplemental reservoir, 26, and on the right side; that is, "the side of the abutment opposite to that which is open to the brake-pipe connection." Port 32 permits such communication in release position. Each thus serves to produce equality of pressure. But defendant contends that the equalizing port of the fourth claim is port 32, and not port 36. The question is whether the language of the fourth claim can be so construed as to refer to port 36 of the patent. This question must be answered in the negative for the following reasons: (1) The port of the fourth claim is "a supply port, leading from the abutment chamber to the valve seat on the side of the abutment opposite to that which is open to the brake-pipe connection." Port 32 is described in the specification as "an equalizing supply port, 32, * * * equilibrium of pressure in the chamber above and below the piston being thereby established, and the discharge valve held to its seat." (2) The function of port 32, as stated in the specification, is "to institute an equilibrium of pressure, and hold the discharge valve to its seat." Port 36 is described in the specification and claimed in claim 5 as "a secondary equalizing port, 36," and its function is twice stated to be to maintain an equalization of pressure. (3) But of the two equalizing ports of the patent port, 32, is the one which deals with the supply of pressure directly from the main reservoir. It is the one which first and "at the same time" institutes equality of pressure as the brakes are released. Port 36, on the other hand, only secondarily serves to maintain the pressure originally supplied by port 32, and it does this not directly from the main reservoir, but indirectly after the pressure has passed by the check valve, and through passages 34 and 29. The expert for complainant admits that it is "not an essential communication perhaps, but an unobjectionable one."

Complainant contends that the secondary equalizing port, 36, is the port of particular importance, for various reasons, and therefore that the court should so interpret the claim as to hold that it covers port 32, instead of port 36. But while this court may resort to the language of the specification for the purpose of interpreting the claim, it cannot read into such claim elements not specifically covered thereby, especially where to do so would be to contradict the clear and definite statement in the specification. When the terms of the claim are clear and distinct, the patentee cannot claim anything beyond for the purpose of establishing infringement. *Keystone Bridge Co. v. Phoenix Iron Co.*, 95 U. S. 274, 24 L. Ed. 344; *Merrill v. Yeomans*, 94 U. S. 568, 24 L. Ed. 235; *McCarty v. Railroad Co.*, 160 U. S. 110, 16 Sup. Ct. 240, 40 L. Ed. 358. As was said in *White v. Dunbar*, 119 U. S. 47, 7 Sup. Ct. 72, 30 L. Ed. 303:

"It is an injustice to the public, as well as an invasion of the law, to construe it [the claim] in any manner different from the plain import of its words."

The fourth claim is not infringed.

A more difficult question arises as to the infringement of claim 8. This is a broad claim, covering the elements of the patented combination concerned in the release, service, and emergency operations. It covers, inter alia, a main regulating valve, 5, "controlling ports by which, respectively, an equilibrium of pressure is established, and a difference of pressure is effected on opposite sides of the abutment." The object of this construction, as shown in the specification, is to keep the ports open or closed by varying the equilibrium of pressure on the opposite sides of the piston. It is effected through the operations of the main valve in so changing the preponderance of pressure on the opposite sides of the piston that through its discharge valve, 21, it shall control the service discharge passage. It is clear that defendant's main regulating valve does not thus control such ports. The positive movement of said valve directly opens the passage. The differences in the organization of the two structures are substantial, and cause radically different modes of operation. In view of the secondary character of the patented invention, the claims in suit cannot be so extended or perverted as to cover the defendant's device.

Disregarding the differences of form and structure and details of arrangement, the combination of the defendant's apparatus is not that of the claims of the patent merely because it will do the same work in one of the several operations which it is devised to effect. If it be conceded that it will do that work in substantially the same way, infringement is not thereby established. Substantial identity between the combinations must be found in their capacity to do the same work in substantially the same way, and it does not suffice to show that they will do one part of their work, viz., perform one application of the brakes, in substantially the same way. The argument for the complainant seems to proceed upon the theory that the combinations are substantially the same because each will perform the several operations of the system, and each is composed of essentially the same devices. The answer is that the differences in organization introduce different

modes of operation except in a single instance, and the identity is incomplete, being partial, instead of general.

The decree is reversed, with costs, with directions to the court below to dismiss the bill.

JOHNSON CO. V. TOLEDO TRACTION CO.

(Circuit Court of Appeals, Sixth Circuit. January 6, 1903.)

No. 1,089.

1. PATENTS—INVENTION—NEW USE OF OLD DEVICE.

To sustain a patent for a new use of an old process or device, there must be some change in the manner of application or some result substantially distinct in its nature. If the new use is so nearly analogous to the former ones that the applicability of the device would occur to a person of ordinary mechanical skill, it is only a case of double use, and no invention is shown.

2. SAME—RAILWAY SWITCH WORK.

The Moxham patent, No. 536,734, for a railway switch structure, in which there is a recess or pocket for containing a removable plate of more durable quality than the remainder of the track, and which is grooved to form the flangeway and point, is void for lack of invention, in view of the structures of the prior art, upon which that of the patent is merely an improvement, made to meet new conditions brought about by the modern street railway service, and requiring the exercise of nothing more than ordinary skill of the mechanic.

3. SAME.

The Moxham patent, No. 540,796, for an improvement on the railway switch structure of patent No. 536,734 to the same patentee, the essential feature of which is the use of molten zinc or other retaining metal as a means for securing the removable plate in the pocket, is void for lack of invention, in view of the long and well-known use of that and similar soft metals for analogous purposes.

Appeal from the Circuit Court of the United States for the Northern District of Ohio.

For opinion below, see 116 Fed. 490.

This is a bill to restrain infringement of the first five claims of patent No. 536,734, and also of the only two claims of patent No. 540,796, both being patents issued to Arthur J. Moxham, and assigned to the Johnson Company, a corporation of Pennsylvania, the complainant below and appellant here. Both patents are for improvements in railway switch work, the second being only for an improvement upon the claims of the first. The inventor states in his specifications to his first patent that his invention "relates to frogs, crosses, mates, and similar structures in railway tracks, and consists in a structure in which the part subject to the most wear may be made more durable than the remainder of the switch piece and removable therefrom," and that the object of his invention is to provide a switch piece in which is inserted, at the point of excessive wear, a plate of more durable quality than the remainder of the track, and one which may be readily removed for realignment or replacing when desired. We insert below Figs. 3, 4, and 5 from the drawings of patent No. 536,734. Fig. 3 is a top view of a frog embodying the invention. Fig. 4 is a transverse section of Fig. 3 on line X, X, and Fig. 5 a longitudinal section of Fig. 3 on line W, W. The central portion, A, is formed by casting it of steel of the proper form, having a pocket or orifice adapted to receive the plate, B. This central casting, A, has also formed upon it short projections, conforming to the shape of the abutting

¶ 1. See Patents, vol. 38, Cent. Dig. § 31.

A. J. MOXHAM.
RAILWAY SWITCH WORK.

No 536.734

Patented Apr. 2, 1895.

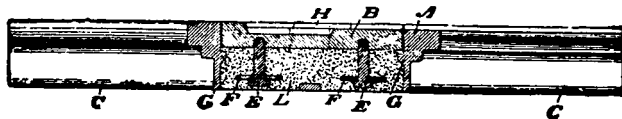

Fig. 5.

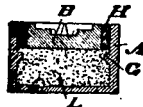

Fig. 4.

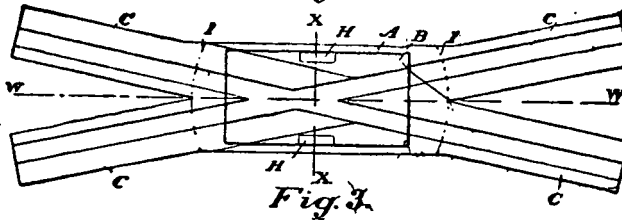

Fig. 3.

rails and in alignment therewith. To these projections are secured the abutting rails. They may be welded thereon by electricity or otherwise, or the projections may be long enough to permit of the usual splice bar joint. "The plate, B, may be either forged, rolled, or cast. Where it is rectangular, as in the case of the frog, I roll a bar of the desired width and thickness and cut the plates of the proper length from it. I then plane or mill the desired grooves through it to conform to the heads and grooves of the abutting rails. This plate may be made of harder steel than the rest of the switch piece, and, if desired, it may be made more durable by hardening, as case hardening, the upper surface. If cast iron, the wearing surface should be hardened by chilling. I will now describe my method of securing the plate in place in the pocket. In the bottom of the plate I screw bolts, E, having the washers, F. Around the inside of the pocket is a ledge or offset, G. I secure the plate in place, and fill the space beneath it with cement or melted sulphur, L, or some similar substance, which, when soft, will readily flow around the bolts and bond the whole in place; the ledge, G, holding it in position. When at any time it becomes necessary to remove the plate, it can be readily done by pulling up with sufficient force to fracture the cement or other filling. H, H, are dovetails in the side of the plate adapted to receive lewises when it is desirable to remove the plate." Claim 1 of this patent is in these words: "A railway switch structure, which consists of a metallic structure provided with a pocket in which a plate, which is grooved so as to form the flangeway and point, is removably secured; the rails of the remainder of said switch being secured to said metallic structure." The other claims vary little from the first claim. The second claim does not expressly describe the plate as removable, but adds the limitation that the rails shall be integrally secured to the principal structure. Claims 3 to 5 express the same combination in slightly different ways.

The two claims of patent No. 540,796 include the important features of the first patent, the difference being that a specific mode of securing the grooved plate in the pocket is included as an element in each. This specific method involves a pocket with inclined sides, larger at the bottom than at the top. The plate, B, is also formed wedge-shaped, and molten zinc is poured in the

space between the walls of the pocket and the plate. This zinc, when hardened, is said to secure the plate firmly in place. Figs. 4 and 5 of the drawings are inserted below:

A. J. MOXHAM
RAILWAY SWITCH WORK.

No. 540,796

Patented June 11, 1895.



Fig. 5.

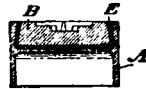

Fig. 4.

The space filled in by the molten zinc is shown at E. The specifications add that, "when at any time it becomes desirable to remove the plate, it is readily done by cutting away the zinc at E, and lifting the plate out, or, instead of cutting the zinc out, the plate might be heated sufficiently to melt it and so allow the removal of the plate." The claims of this second patent are as follows: (1) "A railway switch structure, comprising a body portion having the diverging rails secured thereto and having a pocket adapted to receive a plate, a plate in said pocket having flange ways and the point formed thereon, and a retaining material between the plate and sides of said pocket whereby the plate is held in position in said pocket." (2) "In a railway switch structure, in combination with a body portion having a pocket, a plate in said pocket having track surfaces formed thereon and a filling material between the plate and the sides of the pocket."

The court below held all the claims void for want of patentable novelty, and also held that there had been no infringement, if valid.

George T. Harding and John R. Bennett, for appellant.

Paul A. Staley and Border Bowman, for appellee.

Before LURTON, DAY, and SEVERENS, Circuit Judges.

LURTON, Circuit Judge, after making the foregoing statement of the case, delivered the opinion of the court.

Stated broadly, the claims involved present the question as to whether it was invention to devise a switch structure in which is a recess or pocket for containing a removable plate, which is grooved so as to form the flangeway and point, the rails of the track being secured to said structure in either of two well-known ways, and whether the use of molten zinc or other retaining metal as a means for securing the plate removably in its pocket involves invention. Omitting for the present the feature of the use of molten zinc as a means for securing such a plate in position, which is an element only in the claims of the second patent to Moxham, we shall deal with the question independently of that specific mode of retention.

Railway switch structures, having a metallic body portion with a recess for holding removable parts of the structure much subject to

wear, and having projections to which the connecting rails are to be secured, were old. The Griggs patent, No. 337, issued in 1837, after reciting that frogs had been theretofore cast or constructed in one piece, forming the two crossing rails, and that the rails at such intersection are liable to greater wear and injury than the abutting rails, and therefore require more frequent replacement, proceeds to point out a remedy, which the inventor says "consists in so casting or making the frog, or so forming it, by cutting or otherwise, so as to admit of frog plates of steel, iron, or other suitable material being let into the rails and forming a part of the track for two or three feet, more or less. * * * The frog plates are fastened to the body of the frog by countersunk bolts, fastened on the lower side by nuts and screws, or by keys, or they may be fastened by being filled with some exactness to the space left in the frog to receive them, and by being driven firmly into such space, or they may be otherwise fastened; the mode of fastening being a mere matter of ordinary mechanical skill." The claim allowed was for the frog plates thus described and applied, "of whatever material formed, and however attached to and connected with the main body of the frog." Thus this patent discloses the device of removable hardened plates secured to the body portion of a railway frog at the points of greatest wear. It is also an instructive patent in respect to the mode of securing such plates to the frog, and points out one method,—that of so casting or forming the body portion as to admit of the plates being "let into the rails and forming a part of the track for two or three feet, more or less." Though the plates thus secured are to be secured by bolts and keys, the inventor plainly refuses to limit himself to such a mode by claiming every mode of fastening as a mere matter of mechanical skill. The inventor also foresaw that the channel at the bottom of the flange would wear where the flange of the wheel strikes in passing from one rail to the other, and to remedy this he points out that frog plates may be secured to the floor of the frog in the same manner. This Griggs patent, however illy adapted to the great trains and heavy engines of the developed steam railway, or to the modifications incident to the modern street railway, with its sunken rails and its heavy cars swiftly drawn by electric power, is nevertheless the pioneer in the art of guarding against the excessive wear of the most-used parts of railway crossings by means of removable plates of harder metal. Whatever steps have been since taken to meet changing conditions of traffic carried on rails by either steam or electricity are in the last analysis but improvements upon the device of Griggs, a device almost coeval with the birth of steam railways.

The Curtis patent, of 1852, is another example of an early device for a metallic structure for the body of the frog with a centrally formed pocket for containing a removable frog point or tongue. Here the opening or recess for the frog point is in the body portion of the frog, and the point is removably pocketed in the body portion of the frog. It differs from the Griggs device, where the plates are let into the rails, rather than into the floor of the frog body, as in Curtis. The claim that the point in the Curtis patent is not pocketed,

because a part of it projects above the floor of the frog, is not very relevant. The value of being wholly or partly recessed or pocketed depends upon whether the structure is to be used upon an ordinary steam railway, where the tracks are above ground and the switch structures built up, or upon a street railway, where the convenience of other street uses require that the rails and switch structures shall be below the surface.

The reissue patent of 1864, to Lewis, shows a switch structure with a steel frog point of dovetail shape fitted into a dovetailed pocket formed in the body of the frog. As a means of fastening, a dovetailed block of metal fits between the end wall of the pocket and the pocketed frog point, as in the Moxham structure. The structure also shows a number of steel plates secured by rivets to other wearing points of the structure.

The English patent to Kenway shows a switch structure having a body portion, with a pocket into which a grooved plate is inserted in such a way as to be removable. This separate plate is secured in its socket by lugs, which pass through holes in the bottom of the pocket. Wedges are then run through holes in these lugs after the plate is in position.

It may be admitted that in none of these earlier patents do we find any precise anticipation of Moxham's device. But when the change from horse cars to electricity occurred, and heavy cars running swiftly upon sunken tracks in city streets raised the problem of how to deal with the question of the wear at the intersection with other lines, it would naturally occur to the street railway constructor to study existing methods in the allied industry of ordinary steam railways. We are not insensible to the fact that the old switch structure was not well adapted to the paved streets of a city, where the rails are sunken to diminish the inconvenience of ordinary street traffic. Neither is the switch work of an ordinary railroad subjected to the constant succession of jars and hammering blows incident to the multiplied traffic of a street railway intersection. That a flange bearing of removable hardened metal is required by a street frog or switch is due to the narrowness of the usual street car wheel and its consequent tendency to cut or dig a path in the floor over which it passes in going from one rail to another; a tendency not so noticeable in an ordinary railroad because of the wider tread of the car wheels and far less use. So, it was comparatively easy and cheap to take up and replace the whole frog when the structure was on top of the ground, while the paved streets of a city and the sunken rails required a switch structure difficult to remove, and rendering a removable wearing center much more desirable and economical, even if the wear were no greater in the one situation than the other. While, therefore, street and ordinary railway switch structures belong to the same general art, it is plain that the conditions presented by the modern street railway would present problems somewhat differing from those met by the early patents we have referred to, which were well adapted to the ordinary railroad and also to the horse street car. Nevertheless, it is a far-drawn argument to say that the devices from Griggs to Moxham were a mere groping

after the advantages first realized by the latter. The developments from the devices of Griggs, Curtis, Lewis, and others were not brought about by the defects of those appliances when applied to the railways they were intended to subserve, but by the new conditions brought about by the modern street railway service.

After a careful consideration of the expert evidence, the patents in evidence and the argument of counsel, we are unable to find that the circuit court erred in finding that the improvement made by Moxham involved nothing more than the ordinary skill of the mechanic acquainted with the art and with the new conditions to which the old devices were inadequate. This is strikingly illustrated by the history of the Moxham inventions as detailed by complainant's witness, O'Shea. This witness was manager of the switch works department of the complainant's business for years, and had charge of the manufacture of special work for street railways, and was a skillful draughtsman. Being asked how the making of these special switch structures came about, he said:

"A. Owing to the departure of the traffic from horse cars to motor cars, and the wear on the rails becoming greater, the intersection wore down much quicker than formerly on the first cars, and it was then taken up among all of us to see what could be devised that would make the intersection points hold up a longer period. Mr. Moxham suggested that some kind of a hardened center should be used, and gave unto me the working up of the details.

"Q. You may go ahead and state the result.

"A. Well, after considerable trouble I was successful in Harveyizing or hardening the plate that we thought would accomplish the purpose, and to the best of my knowledge it had done so up to the time of my departure, in 1895.

"Q. You may go ahead and state what means you adopted, as you state that the detail was left to you of holding this plate.

"A. Well, the plan that I adopted was the one shown on that sketch,—the first, that I made marked 'Original.' The first ingredient that I used in trying to hold the plate down was sulphur or brimstone, but we found that this worked loose, and then we took up the plan as shown on that sketch, marked 'Original,' to hold it down."

But it remains to inquire whether the special method of retaining the switch plate in its pocket by a soft retaining metal, which is an element in the claims of patent No. 540,796, involved invention. It is abundantly shown that in various branches of machine and foundry work soft retaining metal has been long used as a cheap device for fastening parts together and also for holding parts in alignment. Examples are shown in journaling harvesting machinery, hanging mill stones, in the construction of illuminated basements for buildings where the roof is used as a sidewalk, and wearing plates in mill machinery; and according to the evidence of competent machinists it has been a common practice in shops to use lead or zinc or other soft metal for leveling plates or castings, so as to adjust them and make them rigid or solid. Numerous other instances of the use of a retaining metal are shown, such as securing foundation bolts, securing verandas, putting bolts into coping stones, joining the ends of cast-iron pipes, such as soil or sewer pipes, in the construction of doorknobs, in which the shank of the knob was of a dovetailed or wedge shape; a soft retaining metal being used to retain the shank in its recess. Now, it is plain that in all these instances the use or

function of the molten metal is simply to retain the parts thus joined in their place rigidly.

Conceding, as we must, that Moxham was the first to use a retaining metal for holding a removable switch plate in its pocket, the practice of using a soft metal for retaining other mechanical parts in adhesion and rigidly was not new. Moxham used the metal in substantially the same way. The function which his retaining metal discharges is precisely the function discharged in the mill machinery step box, called the "Grunwold Step Box," to say nothing of the other instances included in the illustrations referred to above. At most he has used an old practice or idea in a new situation. Its well-known uses would plainly suggest its use in securing his plate in its pocket. Having all of these old uses of spelter before him, and he is chargeable with a knowledge of so common a method of uniting two parts rigidly and yet in such manner as that they might be separated without destroying either, it did not involve invention to employ the same practice in railway switch structures. If the strain to which the parts joined by such a method of fastening will be peculiarly aggravated, because they are parts of a switch structure, it is a difference in degree, and not of kind. There was no substantial difference in the method or purpose in using zinc as a means of retaining Moxham's plate in its pocket over its former well-known use in other branches of the founder's or iron worker's art. The only difference, as observed in *Manufacturing Co. v. Cary*, 147 U. S. 623, 633, 13 Sup. Ct. 472, 37 L. Ed. 307, is "in the use to which the resulting article is put." The well-known ductility of zinc had caused its use as a retaining metal, and this ductility was the best guaranty that it would stand blows and strains without loosening,—qualities which every skilled mechanic is taken to know. Its use by Moxham was plainly analogous to its former uses as a retaining metal, although never before applied in railway structure. It is merely a case of new use, without any change in the method of using the old element to adapt it to the new use or any new mode of application. In *C. A. Potts & Co. v. Creager*, 155 U. S. 597, 608, 15 Sup. Ct. 194, 199, 39 L. Ed. 275, 279, it was said:

"If the new use be so nearly analogous to the former one that the applicability of the device to its new use would occur to a person of ordinary mechanical skill, it is only a case of double use."

There will always be a point where ordinary mechanical skill and invention are so closely associated as to make it difficult to say upon which side of the line the particular matter lies. Where this is the case the doubt should be settled in favor of the patent. But by analogy to a number of well-known precedents we have no trouble in holding that the present case is not one of invention. *Manufacturing Co. v. Cary*, 147 U. S. 623, 13 Sup. Ct. 472, 37 L. Ed. 307, would seem to be peculiarly applicable to the case before us. The invention there involved was a method of restoring steel wire, which had lost its elasticity by mechanical straining, by subjecting it to given temperatures. The patent was limited to its application to "furniture or other coiled springs." It was held, however, that the process, as applied to those springs, was not different in method or effect from the same process when applied to any mechanically strain-

ed wire, or to steel made in straight pieces or strips, and that the invention was anticipated because the same method had been before used with wire clock bells and in blue haired springs and in marine clocks. To the argument that the prior use of the method with wire clock bells was for a different purpose from that contemplated by the inventor, and that the results were not analogous, the court replied:

"But we are of opinion that in the Cary process and the bell-making process the operations are precisely the same. In both, the operator is dealing with wire which is strained by being bent past the elastic limit, and is deadened thereby. The wire is blued by subjecting it to a degree of heat sufficient for the purpose, and is then allowed to cool. The result in both cases is the same, namely, the restoration, stiffening, and equalizing of the wire, and the only difference is in the use to which the resulting article is put. In both, the wire is made stiffer and more spring-like; these qualities being utilized, in one case in a furniture spring, and in the other in a clock bell. Cary observed that, in winding furniture springs, the wire, already weakened by the drawing process, was still further strained and deadened, so as to impair the quality of the spring. The question was how to equalize and stiffen the mechanically strained wire. The same problem had been solved by the clock bell makers, and the solution of the problem was merely the use of the knowledge possessed by those skilled in the art. The wire used in making the clock bells was also hard-drawn wire; but it does not appear that the process of the patent acts differently, when applied to strained hard-drawn wire, from what it would if applied to strained wire that was not hard-drawn. The difference contended for by the plaintiffs, between the process of bluing wire clock bells and the process of bluing furniture springs, in that one deals with spiral articles and the other with articles of a helical form, is not a difference in the process, but is at most a difference in the articles to which the process is applied. If the straining of furniture springs is peculiarly aggravated because of their shape, the difference is merely one of degree, not of kind."

In *Pennsylvania R. Co. v. Locomotive Engine Safety Truck Co.*, 110 U. S. 490, 4 Sup. Ct. 220, 28 L. Ed. 222, a patent was held void for a device which employed an old and well-known method of attaching car trucks to the forward truck of a locomotive. In that case the rule applicable was thus stated:

"That the application of an old process or machine to a similar or analogous subject, with no change in the manner of application, and no result substantially distinct in its nature, will not sustain a patent, even if the new form of result has not before been contemplated."

In *Mast, Foos & Co. v. Stover Mfg. Co.*, 177 U. S. 485, 20 Sup. Ct. 708, 44 L. Ed. 856, invention was denied to one who had adapted to a windmill the combination of an internal toothed spur wheel with an external toothed pinion, for the purpose of converting a revolving into a reciprocating motion. Yet in that case it was conceded that the device had been applied by the inventor when it had not been before used for that purpose. "The transfer," said the court, "did not arise to the dignity of invention," although the result added to the efficiency and popularity of the earlier device.

In *Frederick R. Stearns & Co. v. Russell*, 29 C. C. A. 121, 85 Fed. 218, this court held that it was not invention to transfer a device for lifting and holding and moving small articles, like pieces of cloth, metal, or paper, from one place to another, by attaching them to the ends of hollow tubes connected with an exhaust chamber from which the air was withdrawn by a pump or other exhausting device, to the pill-making business, when the same device was used with substantially no change for holding pills while dipping them in a gelatine bath.

Pertinent to the facts of the case at bar are the cases of Manufacturing Co. v. Cary, 147 U. S. 623, 13 Sup. Ct. 472, 37 L. Ed. 307; Ansonia Brass & Copper Co. v. Electrical Supply Co., 144 U. S. 11, 12 Sup. Ct. 601, 36 L. Ed. 327; Schrieber & Sons Co. v. Grimm, 19 C. C. A. 67, 72 Fed. 671; Aron v. Railroad Co., 132 U. S. 84, 10 Sup. Ct. 24, 33 L. Ed. 272; Brown v. Piper, 91 U. S. 37, 23 L. Ed. 200; Roberts v. Ryer, 91 U. S. 150, 23 L. Ed. 267; Griswold v. Wagner, 15 C. C. A. 525, 68 Fed. 494. The cases cited above from the supreme court and from this court would seem to establish the necessity of some change in the manner of application, or some result substantially distinct in its nature, before a patent can be sustained, based upon a new use of an old process or device.

We find no error in the decree of the circuit court, and it is accordingly affirmed.

AMERICAN BELL TEL. CO. v. NATIONAL TEL. MFG. CO. et al

(Circuit Court of Appeals, First Circuit. January 16, 1903.)

No. 401.

1. PATENTS—INVENTION—TELEPHONE TRANSMITTERS.

The Berliner patent, No. 463,569, for a telephone transmitter, issued in 1891, on an application filed in 1877, does not disclose the principle of the microphone first described by Prof. Hughes in 1878, nor did it add anything of practical value to the knowledge of the telephonic art. It discloses invention, but must be limited, in view of the prior inventions of Bell and Edison, to a transmitter in which the pressure at the point of contact between metallic electrodes in constant contact is varied by the vibration of the diaphragm due to sound waves, and thus produces variations of electrical resistance whereby speech may be transmitted. As so construed it is not infringed by transmitters which embody the discoveries of the carbon electrode and the microphonic principle.

Appeal from the Circuit Court of the United States for the District of Massachusetts.

Frederic H. Betts, William K. Richardson, and Richardson, Herrick & Neave, for appellants.

Edward P. Payson, for appellee Arthur F. Boardman.

Samuel W. Emery, for appellees National Tel. Mfg. Co. and James D. Featherbee.

Robert S. Taylor, for appellee Williams Electric Co.

Before COLT and PUTNAM, Circuit Judges, and ALDRICH, District Judge.

COLT, Circuit Judge. This is an appeal from a decree of the circuit court dismissing a bill brought for infringement of letters patent No. 463,569, issued November 17, 1891, to the American Bell Telephone Company as assignee of Emile Berliner. A caveat describing the invention was filed April 14, 1877, and the application for the patent June 4, 1877. The patent is for a battery telephone transmitter of the variable resistance type.

A battery transmitter is one in which a battery or strong current is utilized for the transmission of speech, as distinguished from a magneto transmitter, in which only a feeble current is generated by

induction. It requires a battery current to transmit speech long distances. The variable resistance type of transmitter utilizes a battery current for the transmission of speech by varying the electrical resistance in the circuit. Variable resistance means simply variable obstruction to the passage of the current. Variable resistance changes the strength or intensity of the current, and, if these changes correspond to the changes in the density of the air caused by sound waves, we have a current whose electrical undulations or vibrations are similar in form to sonorous vibrations or sound waves, and which will transmit speech. In a telephone transmitter variable resistance refers to the changes in resistance which take place at the contact between the two conductors or electrodes, produced by the vibrations of the diaphragm caused by the sound waves.

The Berliner transmitter, covered by his patent in suit, utilizes a battery current for the transmission of speech by varying the electrical resistance in the circuit. The following drawing from the patent shows the Berliner telephone, in which Fig. 1 is the transmitter in controversy, and Fig. 2 the receiver:

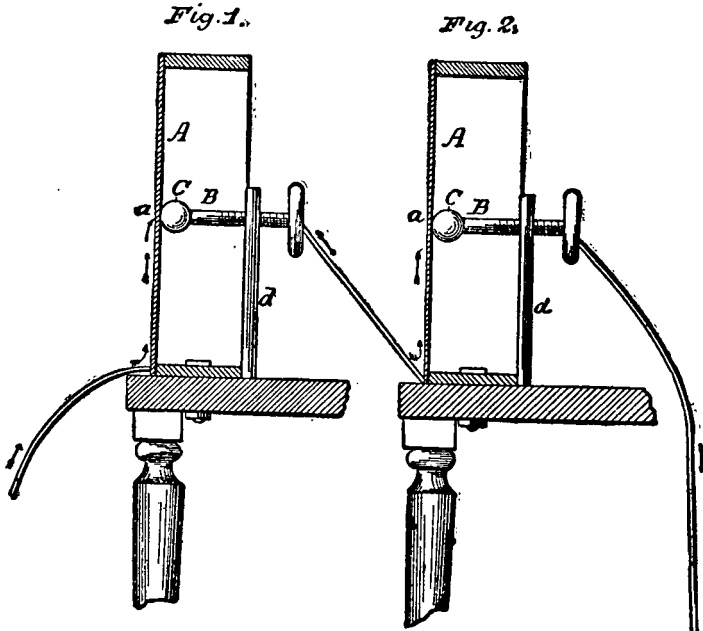

In this drawing, as appears from the specification, A is a metal plate which vibrates when sound is uttered against it. Against this plate, and touching it, is the metallic ball, C, at the end of the screw-threaded rod, B, which is supported by the bar, d. The pressure of the ball, C, against the plate, A, can be regulated by turning the rod, B. The ball and plate are included in circuit with an electric battery, so that they form electrodes, the current passing from one of them to the other. By making the plate vibrate, the pressure at the point of contact becomes weaker or stronger as often as vibrations occur, and the strength of the current is thereby varied accordingly.

By placing another instrument capable of acting as a telephonic receiver, as shown in Fig. 2, in the same electric circuit, sound uttered against the plate of Fig. 1 will be reproduced by the plate of Fig. 2; for, as the vibrations of the transmitter diaphragm caused by the sound will alternately weaken and strengthen the current as many times as vibrations occur, the diaphragm of the receiver will be caused by these electrical vibrations to vibrate at the same rate and measure. The latter vibrations being communicated to the surrounding air, the same kind of sound as uttered against the transmitter, Fig. 1, will be reproduced at the receiver, Fig. 2. It is not essential that the plate should be of metal. It may be of any material able to vibrate, if only at the point of contact suitable arrangement is made so that the current passes through that point. It may be of any shape or size, or other suitable vibratory medium may be used; for example, a wire. Any other metallic point, surface, or wire may be substituted for the ball.

From this description in the patent we find that the Berliner transmitter consists of a battery circuit with two electrodes in constant contact. One electrode is composed of a diaphragm or plate of metal or other vibratory material, and the other electrode of a metallic ball or point. Sound uttered against the diaphragm causes it to vibrate. These vibrations vary the pressure between the electrodes at the point of contact so as to strengthen and weaken the contact, and thereby vary the electrical resistance of the circuit.

The following claims are in issue:

"(1) The method of producing in a circuit electrical undulations similar in form to sound waves by causing the sound waves to vary the pressure between electrodes in constant contact so as to strengthen and weaken the contact and thereby increase and diminish the resistance of the circuit, substantially as described.

"(2) An electric speaking telephone transmitter operated by sound waves, and consisting of a plate sensitive to said sound waves, electrodes in constant contact with each other, and forming part of a circuit which includes a battery or other source of electric energy and adapted to increase and decrease the resistance of the electric circuit by the variation in pressure between them caused by the vibrational movement of said sensitive plate."

These claims must be read in connection with the disclaimer of the patent, which declares that the patentee does not claim to be "the first inventor of the art of transmitting vocal and other sounds telegraphically by causing electrical undulations similar in form to the sound waves accompanying said sounds," nor to be "the first who caused such electrical undulations by varying the resistance of an electric circuit in which a current was passing."

In view of this disclaimer, the first claim covers only the particular method described for varying the resistance in the circuit to produce electrical undulations similar in form to sound waves, and the second claim covers only the instrument or transmitter which embodies this method.

The complainant mainly relies on the first or method claim. It is contended that the invention covered by this claim was first disclosed by Berliner in his caveat of April 14, 1877. This invention was the method of varying resistance in the circuit by varying the pressure at the point of contact between solid electrodes in constant

contact. This way of varying the resistance, it is said, is the same as that disclosed by Prof. Hughes a year later, on May 9, 1878, in a paper read before the Royal Society of London. Hughes called his instrument the microphone. The complainant rests its case upon the identity of the Berliner and the Hughes methods of varying the resistance, and upon the priority of invention by Berliner. In the language of complainant's brief: "It cannot be seriously denied, and none of the witnesses deny, that the Hughes article and the caveat describe the same invention." "The complainant stakes its case upon the proposition, firmly established by the testimony, that Emile Berliner was the original and first inventor of the microphone." This position of the complainant is necessary in order to make out infringement. The defendant's transmitters use carbon electrodes, and, unless Berliner first discovered and disclosed the microphonic method of varying resistance, his patent must be limited to the metallic electrodes describes in the specification, and the defendants do not infringe. The issue here raised can be more intelligently considered if we briefly review the state of the art at the time Berliner made his invention.

The speech transmitting telephone presents the problem of the reproduction, by means of an electric current, of a succession of vibrations on the receiving diaphragm which shall exactly correspond to the vibrations of the transmitting diaphragm caused by the air vibrations, or sound waves, produced by the voice in speaking. The problem was rendered more difficult for the reason that the air vibrations caused by the vocal organs in articulate speech are very complex in form.

On March 7, 1876, a little more than a year before the Berliner caveat appeared, Bell's basic patent was issued, disclosing his art of transmitting speech by creating changes of intensity in a continuous current of electricity exactly corresponding to changes of density in the air caused by the vibrations which accompany vocal sounds. This is known as Bell's undulatory current, which simply means an electric current whose undulations are similar in form to sound waves.

The prior current in the Reis telephone would only reproduce musical tones. It would not reproduce the finer and more complex sonorous vibrations upon which depends the quality of sound which characterizes the human voice. This was because the current was intermittent. Bell discovered that the current must be continuous in order to impress upon it changes which correspond to the form of sound waves.

The Bell patent also disclosed several ways of utilizing his undulatory current. One way is known as the "magneto method," in which the current is induced or generated from the magnetic field surrounding an electro-magnet by the movements of the diaphragm caused by sound waves. These movements, by altering the condition of the magnetic field, produce a current which corresponds in form to the sound waves. An undulatory current of this kind, generated by the transmitter itself by means of the slight movements of the diaphragm, is necessarily feeble, and can only transmit speech short distances. Nevertheless, this instrument was the first practical speech transmitter, and the only commercial transmitter in use until it was

supplanted by the carbon variable resistance transmitter. The instrument is illustrated in the following figure taken from the Bell patent:

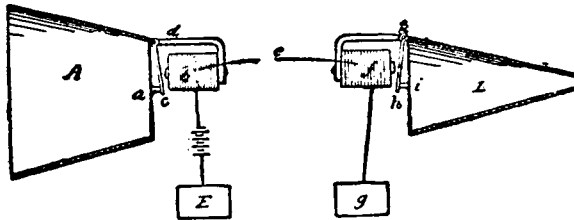

In this drawing, a soft-iron armature, *c*, is caused to vibrate in front of the pole of an electro-magnet, *b*, by means of a membrane diaphragm, *a*, moved by the sound waves, to which diaphragm the armature is attached. This induces or generates an undulatory current in the coil of the electro-magnet, which current passes through another electro-magnet, *f*, in the same circuit, and causes its armature, *h*, to perform like movements to those of the armature of the transmitter, whereupon the diaphragm, *i*, attached to the second armature, reproduces the same sounds as are uttered into the transmitter. Bell subsequently took out a patent for an improved form of this transmitter, in which the diaphragm itself was of metal, instead of being a membrane with an armature attached to it.

Another way of utilizing Bell's undulatory current invented in his 1876 patent was by varying the resistance in a battery circuit. This is made the subject of claim 4, which is for "the method of producing undulations in a continuous voltaic current by gradually increasing and diminishing the resistance of the circuit." The specification refers to this method and apparatus as follows:

"The external resistance may also be varied. For instance, let mercury or some other liquid form part of a voltaic circuit, then the more deeply the conducting wire is immersed in the mercury or other liquid the less resistance does the liquid offer to the passage of the current. Hence the vibration of the conducting wire in mercury or other liquid included in the circuit occasions undulations in the current."

The art, as it was left by Bell's primary patent, may be thus summarized: There existed the undulatory current, the only known current which will transmit speech. There existed one form of its application, known as the "magneto transmitter" or "magneto telephone," which went into extensive use for several years, but which would transmit speech only a short distance, owing to the feebleness of the current. There existed also another way of utilizing the undulatory current by varying the resistance in a battery circuit at the contact between electrodes in constant contact, those electrodes being a solid and a liquid. The instrument embodying this method is known as the "mercury transmitter."

After these disclosures in the Bell patent, the problem which remained was the invention of a practical transmitter which would utilize the undulatory current by varying the resistance in a battery circuit, and so transmit speech long distances. Bell had supplied the

current, and had shown that it could be utilized by varying the resistance in a battery circuit, and what remained was to devise a better way of varying the resistance than was pointed out by Bell. This problem was solved by two discoveries which are now embodied in every commercial transmitter. The first was the discovery of the peculiar properties of carbon in varying electrical resistance, and the second was the discovery of the remarkable effects of sound waves in varying resistance at a loose contact between solid electrodes. Edison made the first discovery, and the fundamental question for our determination in the case at bar is whether Berliner or Hughes first made the second discovery. The instrument which utilizes both these discoveries is called a "microphone transmitter." Every microphone transmitter, as commonly understood in the telephonic art, is an instrument having carbon electrodes in loose or feeble contact. But a transmitter may still be a microphone without having carbon electrodes, provided the electrodes are of solid material, and so capable of embodying microphonic action. It is not pretended that Berliner discovered the carbon electrode, but it is maintained that he was the first to discover microphonic action, and to embody that principle in an operative speech-transmitter. If this be true, the complainant may well insist that the claims of the Berliner patent are not limited to metallic electrodes, but cover the microphonic process or art for the reproduction of sound by varying the electrical resistance in a circuit at a loose contact between solid electrodes in constant contact.

Before the consideration of the microphonic method, and Berliner's priority of invention over Hughes, it may help to throw some light on the subject if, at this stage of our inquiry, we briefly trace the development of the variable resistance transmitter.

After Bell's great contribution to the telephonic art in 1876, the thoughts and efforts of inventors were largely turned in the direction of material and structure, rather than to the discovery of new methods. The only two transmitters then known which used a battery current were the Reis transmitter and the Bell mercury transmitter, and inventors naturally looked for the solution of the variable resistance transmitter problem along the lines of these instruments. A brief reference to these instruments and those which followed, until we reach the commercial carbon transmitter, will prove instructive.

The Reis transmitter employed a battery current. There was a diaphragm set in motion by sound waves, and there were two metallic electrodes in loose inconstant contact in the circuit. This instrument would transmit musical sounds, but not articulate speech, because at every full vibration of the diaphragm the electrodes separated, thereby interrupting the current. In structure this instrument is substantially like the Berliner transmitter. Reis failed because he had not discovered that a continuous current, which requires a constant contact between the electrodes, was essential to transmit speech. In spite of this failure, it has been truly said that the telephonic art owes much to Reis.

The next battery instrument was Bell's mercury transmitter, described in his 1876 patent, in connection with his undulatory current.

This instrument was operative, but not practical. A sketch, in an exaggerated form, is here given:

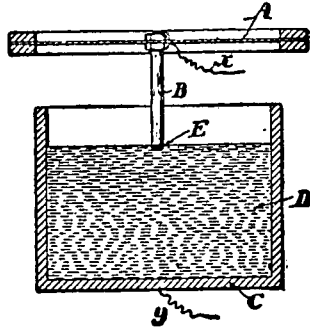

In this drawing A is the diaphragm, B the wire attached thereto, D the mercury or other liquid, and X and Y the circuit connections. As the diaphragm vibrates, the point E moves down and up in the mercury, thereby causing electrical undulations similar in form to sound waves. Here we have a diaphragm set in motion by sound waves, and a metallic electrode and a liquid electrode in constant contact. As the vibrations of the diaphragm cause the metal point to be immersed in the liquid, the less resistance there is to the passage of the current. The way or method of varying the resistance in this transmitter is by varying the area of contact between the two electrodes.

In February, 1877, 11 months after Bell's patent disclosed his mercury transmitter, Edison invented what is known as the "plumbago film transmitter." This instrument utilized Bell's undulatory current in a battery circuit by varying the resistance between solid electrodes in constant contact. It was an operative instrument, but not practical. A sketch of the instrument is here reproduced:

Edison 8-11.

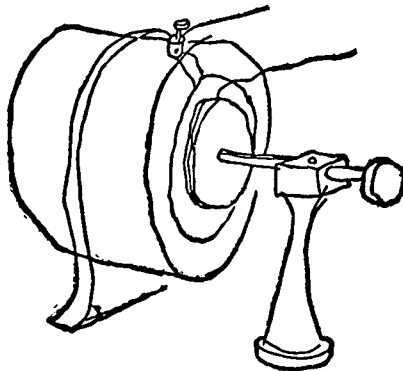

This drawing represents a disk of hard rubber coated with plumbago, which presses against the tinfoil sheet on the diaphragm. One of the line wires is connected to the disk at its upper edge, and the other to the tinfoil sheet on the diaphragm. This sketch was the original from which was made the application for patent No. 474,230. In this instrument we have a diaphragm set in motion by sound waves, and two solid electrodes in constant contact. The vibrations of the diaphragm due to the sound waves caused it to come into greater or less contact with the disk, and so varied the resistance in the circuit. The thin film of plumbago on the disk being a poorer conductor than the metal diaphragm, the movements of the diaphragm cut in and out the resistance of the circuit. The way or method of varying the resistance in this transmitter would seem to be by varying the extent or area of contact surface between the electrodes caused by the vibrations of the diaphragm, although the patent also speaks of the vibrations as causing an increase and decrease of electric energy according "to the intimacy of contact between the vibrating diaphragm and the surface of the adjacent disk."

We come next to Edison's plumbago cylinder transmitter, which bears the date of April 1, 1877, and which is described in its final form in patent No. 474,231. This instrument also utilized Bell's undulatory current in a battery circuit by varying the resistance between solid electrodes in constant contact. It was an operative speech transmitter, but not practical. A sketch of this instrument is here given:

Edison 42-11.

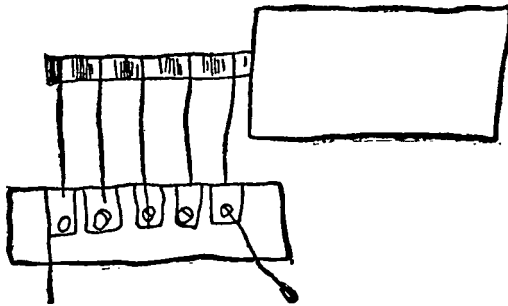

This apparatus comprised a diaphragm in contact with a series of plumbago cylinders mounted on stiff springs, which held them in a state of contact. The diaphragm was in constant contact with the plumbago at one end of the series, and by its vibrations varied the resistance in the circuit. In this instrument we have a diaphragm set in motion by sound waves, and solid electrodes in constant contact. The vibrations of the diaphragm compressed the mass of plumbago, which caused variations of resistance in the circuit. The way or method of varying the resistance in this transmitter is by varying the compression of the mass of plumbago caused by the vibrations of the diaphragm. There would seem to be little doubt that microphonic

action would be present in this transmitter, provided the adjustment between the diaphragm and the plumbago cylinders were such as to make a loose initial contact between them.

Next in the order of time is the Berliner transmitter in suit, described in his caveat of April 14, 1877. This instrument, as we have seen, also utilizes Bell's undulatory current in a battery circuit by varying the resistance between solid electrodes in constant contact. It was an operative speech transmitter. It never went into use, however, as it was not a practical instrument. For the sake of clearness, the drawing of the transmitter is again reproduced:

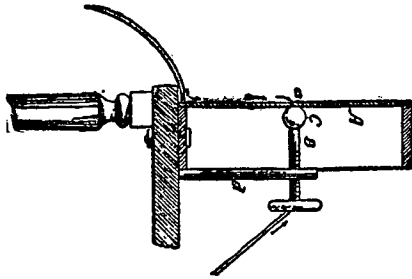

In this instrument we have a diaphragm set in motion by sound waves, and two metallic electrodes in constant contact. The vibrations of the diaphragm vary the pressure at the point of contact, and thereby vary the resistance in the circuit. The way or method of varying the resistance in this transmitter is by varying the pressure at the point of contact, and so varying the intimacy of contact between the electrodes. When the electrodes in this instrument are so adjusted as to be in loose contact we have present microphonic action, and the instrument becomes a microphone transmitter. It may here be observed, however, that our inquiry is not whether the Berliner instrument became a microphone when properly adjusted, but whether Berliner first discovered the microphonic way of varying resistance, and made it known to the world in his caveat.

This brings us to Edison's carbon transmitter, which was invented in the fall of 1877, and is found in patent No. 203,016, dated April 30, 1878. The instrument utilizes Bell's undulatory current in a battery circuit by varying the resistance between two solid electrodes, one of which is carbon. The accompanying figure shows the commercial instrument:

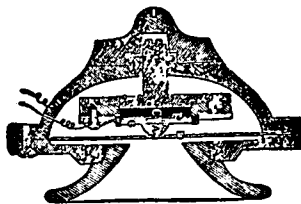

In this figure, D is the metal diaphragm resting by means of the small brass tube, A, upon a disk of hard rubber, G, beneath which is a thin plate of platinum foil, P, connected with the battery. Beneath this platinum foil is a button of soft carbon, C, made of highly compressed lampblack, and beneath this is another thin plate of platinum foil, which is connected to the line through the frame of the instrument. The carbon button, with its inclosing plates, was so mounted as to be capable of adjustment by means of a screw. In this instrument we have a diaphragm set in motion by sound waves, and two solid electrodes in constant contact, one of the electrodes being composed of carbon. "The vibrations of the diaphragm," in the words of the patent, "subject the carbon to different pressures, according to the amplitude of motion resulting from the sound waves, and this difference of pressure varies the resistance offered by the carbon to the passage of the current, and produces a rise and fall of electric tension." The way or method of varying the resistance in this transmitter is by varying the pressure at the contact, and so varying the intimacy of contact between two solid electrodes. In this instrument Edison disclosed to the world his discovery of the special properties of carbon in varying resistance in a telephone transmitter. When the electrodes in this instrument are adjusted in feeble contact, it becomes a microphone.

The Edison carbon transmitter was the first practical long-distance speech transmitter which utilized Bell's undulatory current in a battery circuit by varying the resistance in the circuit. The commercial art passes at once from Bell's magneto transmitter to Edison's carbon transmitter. In December, 1879, there were 34,000 magneto transmitters in use, and 18,000 variable-resistance carbon transmitters. Subsequently the use of the magneto transmitters declined, and they were supplanted by the carbon transmitter. All variable resistance transmitters commercially used have carbon electrodes in loose contact. The alleged infringing transmitters in the case at bar are mere improvements in the structure, form, or adjustment of the Edison carbon transmitter, invented by him in the fall of 1877.

We now pass to the crucial point upon which the complainant rests its case. The complainant's position on this point may be stated as follows:

Berliner first discovered the microphonic method of varying resistance, and first disclosed this method, and an operative instrument embodying it, in his caveat of April 14, 1877. In other words, Berliner first invented the microphone. Bell's mercury transmitter and Edison's plumbago film and plumbago cylinder transmitters are not anticipations, because they do not operate by the microphonic method. They are not microphones. On the other hand, Edison's carbon transmitter and the two carbon transmitters made or used by the defendants infringe the Berliner patent, because they employ the microphonic method, and are microphones. The microphonic method is not limited to the use of the carbon electrode, but only to the use of solid electrodes, or hard and unyielding electrodes; and therefore the carbon electrode, when there is microphonic action, is within the microphonic method, and infringes the Berliner patent. The

microphonic method was disclosed to the scientific world by Professor Hughes in May, 1878, and was regarded as a wonderful discovery. Hughes called his instrument a microphone, from analogy to the microscope, since he believed it would magnify small sounds. The microphonic method of varying resistance, disclosed by Hughes in 1878, was the same as the microphonic method of varying resistance disclosed by the Berliner caveat in 1877. To be sure, the Hughes instrument, which he was the first to term a microphone, was constructed of carbon electrodes; but this is immaterial, because he states that the best material for the electrodes has not yet been discovered, and because his discovery resides in the method of varying the resistance, and not in the materials composing the electrodes. The disclosure by Berliner of the Hughes method of varying resistance is found by the complainant in the following passages from Berliner's patent, which also appear in substantially like form in his caveat:

"It is a fact that if at a point of contact between two conductors forming part of an electric circuit and carrying an electric current the pressure between both sides of the contact becomes weakened the current passing becomes less intense; as, for instance, if an operator on a Morse instrument does not press down the key with a certain firmness the sounder at the receiving instrument works much weaker than if the full pressure of the hand had been used. Based on this fact, I have constructed a simple apparatus for transmitting sound along a line of an electric current in the following manner:

"In Figures 1 and 2 of the drawings, A is a metal plate well fastened to the wooden box or frame, but able to vibrate if sound is uttered against it or in the neighborhood of said plate. Against the plate and touching it is the metal ball, C, terminating the screw-threaded rod, B, which is supported by the bar or stand, d. The pressure of the ball, C, against the plate, A, can be regulated by turning the rod, B. * * * By making the plate vibrate the pressure at the point of contact, a, becomes weaker or stronger as often as vibrations occur, and the strength of the current is thereby varied accordingly, as already described."

The Berliner invention above described consists in the method of varying the resistance by variation of pressure at the point or points of contact between solid electrodes in constant contact.

To determine whether this invention is the same as the Hughes method of varying resistance, it is necessary to have a clear understanding of the nature of the discovery which he revealed to the world on May 9, 1878.

Such portions of the Hughes article as seem material may be summarized as follows:

The introduction of the telephone led Prof. Hughes to investigate the effect of sonorous vibrations upon the electrical behavior of matter. Sir William Thompson and others had shown that resistance to the passage of currents afforded by wires is affected by their being placed under strain, and, inasmuch as the conveyance of sonorous vibrations induced rapid variations in the strain at different points of a wire, Prof. Hughes believed that the wire would vary in its resistance when it was used to convey sound. To investigate this he made a rough telephone receiver or "sound detector," which he connected in line with a battery current in a closed circuit. The apparatus or materials experimented upon were used in the same way as the trans-

mitter of the speaking telephone of Bell. The following is a sketch of his apparatus:

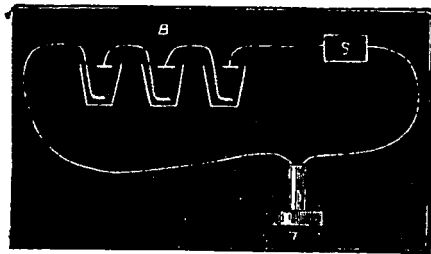

In this drawing, B is the battery, S the source of sound or material examined, and T the telephone. He then proceeds:

"I introduced into the circuit at S a strained conductor,—a stretched wire,—listening attentively with the telephone to detect any change that might occur when the wire was spoken to, or set into transverse vibrations by being plucked aside. Gradually, till the wire broke, the strain was varied, but no effect whatever was remarked except at the moment when the wire broke. The effect was but momentary, but invariably, at the moment of breaking, a peculiar 'rush' or sound was heard. I then sought to imitate the condition of the wire at the moment of rupture, by replacing the broken ends, and pressing them together with a constant and varying force by the application of weights. It was found that if the broken ends rested upon one another with a slight pressure, of not more than one ounce to the square inch on the joints, sounds were distinctly reproduced, although the effects were very imperfect."

Prof. Hughes had now discovered microphonic action, or the mode of operation of the instrument which he calls the microphone, and all that follows in his paper is only the further development of this principle. He sought to investigate the effect of sonorous vibrations or sound waves upon the electrical behavior of matter, and he began his investigation with the belief that such vibrations would vary the electrical resistance of wire under strain. He found no marked effect until the moment when the wire broke or parted contact, when he detected a peculiar "rush" or sound. He then imitated the condition of the wire at the moment of rupture by replacing the broken ends in the apparatus, and pressing them together with a constant and varying force by the application of weights. He discovered that, if the broken ends rested together with a slight pressure of not more than one ounce to the square inch on the joints, sounds were distinctly reproduced. Thus Prof. Hughes, by a process of deduction and experiment, and advancing step by step, made his great discovery of the effects of sonorous vibrations in varying electrical resistance at a feeble or loose contact between two electrodes. When Prof. Hughes placed the two ends of the ruptured wire in contact, he had not discovered microphonic action. When the ends were pressed together with considerable pressure, he had not discovered microphonic action. When the ends were in a very loose contact, he had not discovered microphonic action. But when, after repeated experiments with different degrees of pressure, the broken ends rested upon one another with a slight or feeble contact, his hopes were realized. Hughes did not, like Bell, discover a new current, but he did make known the close affinity between sound waves and an electric current at what electricians were

accustomed to term a "bad joint" in an electric circuit. He discovered the sensitiveness, the adaptability, of the current at a loose or light contact to vary its resistance in conformity with the vibrations of the air produced by sound waves. He discovered a new way of varying resistance which has proved of great utility in the telephonic art. Unless anticipated by Berliner, he was the first to disclose this new way, although previously it may have been present in telephone transmitters without the knowledge of the inventors. Prof. Hughes' discovery lay in loose initial contact between the electrodes. This is the essence of the microphone. With loose initial contact there is microphonic action; without loose initial contact there is no efficient microphonic action. When the contact between the electrodes is greater or less than a feeble contact, such action is either greatly impaired or ceases altogether. Microphonic action, or the microphonic method, or the microphonic process or art, discovered by Prof. Hughes, is simply the effects of sonorous vibrations in varying resistance at a feeble or loose contact between solid electrodes in constant contact, whereby sound is reproduced at the receiver. Microphonic action is dependent upon three simple conditions,—atmospheric vibrations produced by sound waves, two solid electrodes in feeble contact in a line circuit, and a sound-receiving instrument in the circuit. What produces these effects is unknown. Prof. Hughes believed the effects were "due to a difference of pressure at the different points of contact," and that they were "dependent for the perfection of action upon the number of these points of contact." Prof. Bell doubted this, and attributed the effects to "a variation in the amount of contact" supplemented by the heat produced at the point of contact. But what causes these effects is immaterial. What we know is that the phenomenon exists, and was disclosed by Prof. Hughes in this article.

It may here be observed that the discovery of Prof. Hughes relates to the direct effect of the sonorous vibrations upon a loose contact, and that it is not essential to use a diaphragm. The introduction of a diaphragm merely signifies that the sonorous vibrations produce corresponding vibrations in the diaphragm which affect the resistance at the loose contact exactly the same as the direct impact of the sound waves.

We will now resume the consideration of the article from the point where Prof. Hughes discovered microphonic action.

He found it was not necessary to join two wires endwise together to reproduce sound, but that any portion of an electric conductor would do so even when fastened to a board or to a table, and no matter how complicated the structure upon this board, or the materials used as a conductor, "provided one or more portions of the electrical conductor were separated, and only brought into contact by a slight but constant pressure." If the ends of the wire, terminating in two common French nails laid side by side and separated from each other by a slight space, were electrically connected by laying a similar nail between them, sound could be reproduced. "Up to this point," he continues, "the sound or grosser vibrations were alone produced; the finer inflections were missing, or, in other words, the 'timbre' of the voice was wanting; but in the following experiments the 'timbre' became more and more perfect, until it reached a perfection leaving

nothing to be desired. I found that a metallic powder, such as the white powder—a mixture of zinc and tin—sold in commerce as 'white bronze,' and fine metallic filings, introduced at the point of contact, greatly added to the perfection of the result. At this point, articulate speech became clearly and distinctly reproduced, together with its timbre; and I found that all that now remained was to discover the best material and form to give to this arrangement its maximum effect." The paper then proceeds with a description of his experiments with the best material and form to give the maximum effect. He found carbon an excellent material, but he obtained the best results from mercury in a finely divided state. He refers to the fact that in his experiments the diaphragms of Reis, Edison, and Bell have been "altogether discarded," and that "the variations in the strengths of the currents flowing are produced simply and solely by the direct effect of the sonorous vibrations."

After describing the instrument which he calls a microphone, he says:

"The best form and material for this instrument, however, have not yet been fully experimented on. Still, in its present shape, it is capable of detecting very faint sounds made in its presence. If a pin, for instance, be laid upon or taken off a table, a distinct sound is emitted; or, if a fly be confined under a table glass, we can hear the fly walking, with a peculiar tramp of its own. The beating of a pulse, the tick of a watch, the tramp of a fly, can thus be heard at least a hundred miles distant from the source of sound."

He further says:

"It is quite evident that these effects are due to a difference of pressure at the different points of contact, and that they are dependent for the perfection of action upon the number of these points of contact. Moreover, they are not dependent upon any apparent difference in the bodies in contact, but the same body, in a state of minute subdivision, is equally effective."

The instrument he devised is described as follows:

"The microphone, in its present form, consists simply of a lozenge-shaped piece of gas carbon, one inch long, quarter inch wide at its centre, and one eighth of an inch in thickness. The lower pointed end rests as a pivot upon a small block of similar carbon. The upper end, being made round, plays free in a hole in a small carbon block, similar to that at the lower end. The lozenge stands vertically upon its lower support. The whole of the gas carbon is tempered in mercury, in the way previously described, though this is not absolutely necessary. The form of the lozenge-shaped carbon is not of importance, provided the weight of this upright contact piece is only just sufficient to make a feeble contact by its own weight. Carbon is used in preference to any other material, as its surface does not oxidize. A platinum surface in a finely divided state is equal, if not superior, to the mercurized carbon, but more difficult and costly to construct. I have also made very sensitive ones entirely of iron."

A Hughes microphone is shown in the following sketch:

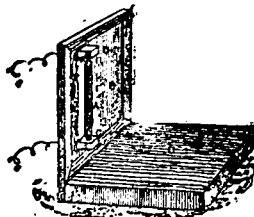
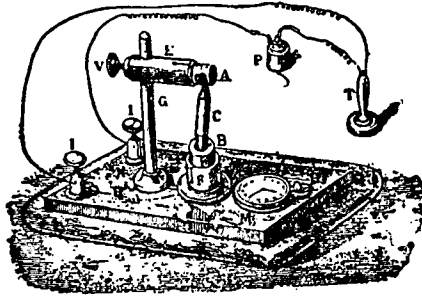

FIG. 11—Hughes's microphone.

In this figure, B and D are two pieces of wood fastened together, with their planes at right angles to each other. Attached to B are two small blocks of carbon, C, C. Between these a light rod, A, of carbon, is supported on small cups in C, C. If this microphone is joined in circuit with a telephone and a small battery, the vibrations produced by a fly walking on the base, D, can be distinctly heard in the telephone.

Another sketch of a Hughes microphone is also reproduced:



(FIG. 6).

In this drawing, the pointed piece of carbon, C, sets loosely in the notches of two pieces of carbon, A, B. If we place our ear at the telephone, T, we shall hear distinctly not only the ticking of the watch, but the friction of the wheels.

Prof. Hughes' article was regarded by the scientific world as disclosing a remarkable discovery. The Journal of the Franklin Institute of June 19, 1878, said:

"Prof. Hughes * * * discovered that when two or more electrical conductors rested lightly upon each other, the variation in the force of contact, caused by exceedingly feeble sonorous vibrations, would so vary the electrical resistance as to take up and transmit these vibrations to the distant telephone with great force and distinctness."

The Russian Messenger, in describing Hughes' discovery, said:

"It occurred to Hughes to investigate whether the transmission of sound waves by a wire had any influence on its ability to conduct a galvanic current. If so, then the change of strength of current ought to act on the telephone, and the latter ought to transmit to us the sound. For a long time Hughes' experiments with a tightly drawn wire were without success; but fortunately, because of its great tension, the wire broke. Not wishing to stop his experiment, Hughes temporarily tied the ruptured ends, and to his astonishment he noticed that after the rupture of the wire the telephone began to transmit sounds much better. Minutely investigating this phenomenon he soon convinced himself that the transmission of sounds by telephone is best accomplished when the ends of the wire touch each other lightly, or, better still, when they are at a certain distance from each other, and between them, in light contact with them, there is another body of good electric conductivity; for example, an iron or brass plate or a piece of carbon. The slightest sound or noise produced near that piece of carbon naturally causes the latter to vibrate. In consequence of these vibrations there is a greater or lesser contact of the conductors of the current, and therefore the latter meets in the circuit a varying resistance, and consequently its strength also varies."

It will be impossible, in our opinion, to find in the Berliner caveat or patent any conception of Hughes' discovery. It would seemingly

appear that Berliner had not advanced so far in his conception of microphonic action as Hughes at the moment he heard a "rush" or sound when the ends of the wire parted contact. It will certainly be made plain that Berliner's conception extended no further than the time when Hughes placed the broken ends of the wire in contact, and began his experiments on the effect of sonorous vibrations at different degrees of constant pressure, which finally led to his discovery of microphonic action.

Always keeping in mind that microphonic action involves the conception of sonorous vibrations and loose contact between electrodes, let us turn to Berliner's conception and invention.

Berliner, as appears from his testimony, having already become familiar with Bell's 1876 patent, commenced in January, 1877, "making experiments" in "the speaking telephone." "Some time," he says, "during that month, one of the operators in the fire-alarm office in Washington, in showing me about the use of the Morse key, explained the importance of pressing the key down firmly upon its rest or base in order to insure the operation of the sounder promptly. He explained that if the key was not firmly pressed down the sounder might fail to respond promptly, and that was a reason why female operators were often objected to because they did not have sufficient strength to give a good contact between the key and its rest. It immediately occurred to me that, if a variation of contact pressure between the circuit-closing key and its rest could produce a variation in the current, then a varying pressure between the points of contact could be obtained by the vibration of one or both of them imparted to them by sounds or sound waves in the air in their neighborhood."

Manifestly, the conception here given is not Hughes' conception; because the essence of microphonic action, which resides in loose contact, is entirely wanting. When the operator told Berliner that the more firmly the fire-alarm key was pressed down the more promptly the sounder operated, he was merely stating a scientific fact, then well known, that the closer the contact ends of a wire in an electric circuit are pressed together the less the resistance, and consequently the greater the strength of the current. Acting upon this information, Berliner says it occurred to him that, if a variation of contact pressure between the circuit-closing key and its rest could produce a variation in the current, then a varying pressure between the points of contact could be obtained by the vibration of one or both of these electrodes, imparted by sound waves in their neighborhood. Berliner's conception of a telephonic transmitter was this: Starting with the electrodes in contact, he conceived that a varying pressure between the points of contact, and a consequent varying of the strength of the current, could be obtained by the vibration of one or both of the electrodes caused by sound waves. This conception does not reach to the character of the initial contact, and therefore does not even approach microphonic action.

Suppose Prof. Hughes had stopped his experiments when he had placed the ends of the severed wire in contact, he would not have discovered microphonic action. Or suppose, after the wire broke, he had said, "I then placed the two ends of the wire in contact, and found that

the sonorous vibrations would vary the pressure at the points of contact, and so vary the strength of the current, whereby sound was reproduced," he would have made no discovery of microphonic action. If, however, Hughes had embodied this conception in a telephone transmitter, he would have made an invention, in that he had discovered that the minute atmospheric vibrations due to sound waves would sometimes so vary the pressure between the points of contact of metallic electrodes as to strengthen and weaken the current, and so reproduce sound. And this is exactly the scope of the Berliner conception, and of his invention. His conception, by reason of the absence of any comprehension of microphonic action, when embodied in a transmitter, produces an instrument which is sometimes operative and sometimes not. If, by accident, the electrodes are adjusted in loose initial contact, or microphonic contact, the instrument may be operative, while, if not so adjusted, it is inoperative.

But while Prof. Hughes, under such circumstances, would have made an invention, he could not have seriously asserted that he had discovered microphonic action; because we know that, when he placed the ends of the wire in contact, he had not made his discovery, and that it was only after repeated experiments with all degrees of contact pressure he found the ends must be placed in loose contact to insure the reproduction of sound.

Contact, or points of contact, are meaningless as a conception of microphonic action. So, likewise, is the conception of varying pressure at the contact or points of contact. A contact, or points of contact, affected by varying pressure, may be a firm contact, in which case there is no microphonic action, or a very loose contact, in which case there is no microphonic action, or any other degree of contact where microphonic action is not present. Microphonic action resides in the conception of a loose initial contact between the electrodes, and it is immaterial to this conception how the sound waves affect such a contact, whether by varying pressure or not. This shows that it is only the clear comprehension of loose contact which can be held to be a conception of microphonic action. A conception of microphonic action which omits loose contact leaves out the very essence of the thing to be conceived.

Berliner testified to this conception of his invention on April 12, 1879, in some interference proceedings. This was two years after the filing of his caveat, and one year after the publication of the Hughes article. So far as this description of his invention may differ from that found in his caveat, we must, of course, be guided by the latter. It is the invention disclosed in the caveat upon which the complainant must, and does in fact, rely.

Berliner begins his caveat by the statement of the fact which the operator had previously told him, though he now speaks of the pressure at "a point of contact" instead of the pressure between "the points of contact":

"It is also a fact that if, at a point of contact between two ends of a galvanic current, the pressure between both sides of the contact becomes weakened, the current passing becomes less intense; as, for instance, if an operator on a Morse instrument does not press down the key with a certain firmness, the sounder at the receiving instrument does work much weaker than if the

full pressure of the hand would have been used. Based on these two facts, I have constructed a simple apparatus for transmitting sound along a line of a galvanic current in the following manner."

The drawing of the transmitter is here reproduced:

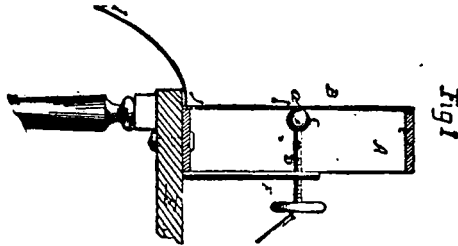

"In the drawing accompanying this caveat, B is a metal plate well fastened to the wooden box or frame, A, but able to vibrate if sound is uttered against it or in the neighborhood of said plate. Against the plate and touching it is the metal ball, C, which rests on the bar or stand, F, and presses against the plate, which pressure, however, can be regulated by the thumb-screw, D, attached to the ball. By making the plate vibrate, the pressure at the point of contact, a, becomes weaker or stronger as often as vibrations occur, and according to it from which side of the plate the sound comes."

It is impossible to find in this language any description of microphonic action.

Referring to the figure, Berliner says:

"Against the plate, and touching it, is the metal ball, C, which * * * presses against the plate, which pressure, however, can be regulated by the thumb-screw, D, attached to the ball."

This is simply saying that the electrodes are in constant contact, and that the degree of contact may be regulated by the thumb-screw. But in what manner it is to be regulated, or what is to be the degree of pressure caused by such regulation, the caveat is silent. Presumably, by experiment with different degrees of adjustment, the pressure between the electrodes is to be so regulated that the instrument will operate to transmit speech. But how can this be said to be a disclosure of microphonic action? The operator gets no knowledge from this description of the degree of initial contact pressure which is necessary. If he presses the ball and plate too closely together, the instrument becomes inoperative. If the contact is too loose, a like result follows. But if, after frequent attempts, he happens to make such an adjustment as gives a feeble contact between the ball and the plate, the instrument may become operative. Can it for a moment be maintained that this is the discovery revealed by Prof. Hughes?

The caveat continues:

"By making the plate vibrate [by sound waves] the pressure at the point of contact, a, becomes weaker or stronger, as often as vibrations occur."

This may all be true, and this feature may have involved invention, but it has no bearing on the disclosure of microphonic action. These words are merely descriptive of what takes place after some kind of an adjustment between the ball and plate has been made. The discovery of microphonic action resides in the particular kind of adjustment, and not in the fact that after such an adjustment the vibrations

of the diaphragm caused by sound waves vary the pressure at the point of contact.

To make still more clear the distance which separated Berliner from any conception of microphonic action, we may turn to another passage from his caveat, which says:

"Same instrument to be used as a transmitter of sound waves, by uttering sound against or in the neighborhood of the said plate or its mechanical equivalent, thus vibrating the plate and diminishing the amount of electricity passing as many times and as much as the vibrations will loosen the pressure of contact, as described."

Berliner's mind was still full of what the operator had told him about the fire alarm. He believed, as this passage shows, that the electrodes must be first firmly pressed together, in which case the current would flow freely, and that the vibrations of the plate due to sound waves would lessen the pressure of contact, and so diminish the amount of current flowing as often as the vibrations occur. He consequently started with a firm initial contact between the electrodes, and his theory was that the vibrations of the diaphragm would lessen the contact. This is the reverse of microphonic action, which starts with a loose initial contact, and, consequently, a greatly diminished flow of current.

On April 30, 1877, 16 days after the filing of the caveat in suit, Berliner filed another caveat, which describes an ingenious arrangement for "producing sound by the noise of sparks." On May 9, 1877, nine days afterwards, Berliner filed a third caveat for what is known as his "double-pin instrument." This was for an improvement on the ordinary make and break transmitter, by the use of a double contact. Then follows, on June 4, 1877, the application for the patent in suit, covering, with the receiver, single-pin transmitters and double-pin transmitters, continuous currents and intermittent currents, in such a confused way that an intelligent and satisfactory interpretation of this document bids defiance to the human understanding. The obscurity of the paper may be in part accounted for by the blunders of the solicitor's clerk, but not wholly; for it is quite manifest that Berliner's ideas at this time as to the best form of transmitter, and the principle of its operation, were unsettled and needed clarification. This course of action on the part of Berliner may not be conclusive of anything. It is sometimes unsafe to infer too much from a subsequent line of conduct. In this particular case, however, we think this much may be said with truth:

Assuming that Berliner on April 14, 1877, had already made Hughes' discovery of microphonic action, his caveat of May 9th and his application of June 4th become incomprehensible.

In this connection it may be noticed that, in his two patents for microphones, No. 222,652 and No. 224,573, applied for more than two years after his caveat, and more than a year after the publication of the Hughes article, Berliner describes the necessity of loose initial contact between the electrodes. In the first instance, one of the electrodes, which is preferably of carbon, is described as "just in contact by its own weight with said plate," and in the claim as "the said non-elastic pin resting solely by its own weight upon the diaphragm."

The second patent is for maintaining the carbon pin constantly in light contact with the diaphragm "by the action of gravity," or, in the words of claim 1, "an opposite electrode maintained in contact with the vibrating surface by the action of gravity." Here is the loose initial contact of Hughes, and the maintenance of such a contact during the operation of the instrument.

Berliner's attempts to make his transmitter reproduce speech were hardly satisfactory; but, as the evidence stands, he succeeded in reproducing some words, and indistinct sentences, so that it may be said there was the transmission of the quality of sound which characterizes the human voice in speaking. In his experiments with the instrument, he says nothing about loose contact between the electrodes, or the necessity of such contact. That his efforts were not more successful he believes was owing to the crudeness of the apparatus and the difficulty of adjusting it. His apparatus, however, was not more crude than the apparatus which Hughes used in his experiments. The unsatisfactory character of Berliner's efforts cannot be wholly ascribed to this cause, nor to the fact that he used metallic electrodes, which, for several reasons, are difficult properly to adjust, nor to both of these causes combined, but must have been due, at least to some extent, to his ignorance of microphonic action. Had he known of Hughes' discovery, the results, in all probability, would have been much more satisfactory. Subsequent experiments, however, have shown that the Berliner instrument can be so adjusted as to become an operative speech transmitter. But the experts who made these experiments, years afterwards, had been long familiar with Hughes' disclosure of microphonic action, and they knew the absolute necessity of loose initial contact between the electrodes in order to make the instrument an operative speech transmitter. They certainly possessed this advantage over Berliner, and the success of their efforts may be attributed in part to this cause.

The complainant's contention that Hughes' discovery of microphonic action is disclosed in the Berliner caveat rests upon general definitions of the microphone and of Berliner's invention rather than upon a critical analysis of the actual discovery revealed by Hughes in his article or a critical examination of the Berliner caveat.

The definition of the Berliner invention is founded on what the complainant conceives to be the "true definition of a microphone," which is as follows:

"The essence of the microphone consists, therefore, in varying the resistance at the 'joint' or point of contact between two electrodes by varying the pressure between them."

But this is not descriptive of the microphone, or of microphonic action, as disclosed by Hughes. "A joint" may be either tight or loose, and a "point of contact" may be either firm or feeble, and the difference between a joint and a loose joint, and a point of contact and a feeble point of contact, is the difference between what is a microphone and what is not a microphone. This is confirmed by the testimony of complainant's experts.

Prof. Cross says, defining microphonic action:

"It is a fact that, when a current passes from one electrode to another kept loosely in contact with it, there is a certain resistance of passage or 'transition resistance,' as it may be called, at the surface of contact between the two electrodes."

And Prof. Wright says:

"When transmitting speech, the electrodes of a microphonic transmitter are brought together with a pressure which is very light, and which has been determined by experiments to vary within a comparatively narrow range."

This error is present in every definition of the microphone and of the Berliner invention in complainant's brief, and it permeates and undermines the fundamental position on which it rests the case.

Again, the Berliner invention is defined as "varying the pressure at a point of contact between electrodes," or "varying the pressure between two electrodes in contact, and thereby varying the resistance in the circuit so as to produce undulatory sound waves." More fully stated, the definition may be expressed as follows: The method of varying resistance by variation of pressure at the point of contact between solid electrodes in constant contact. These definitions are not descriptive of the microphone or of microphonic action, because they omit any reference to loose contact between the electrodes.

The complainant then proceeds to define what it calls Prof. Hughes' "brilliant and radically novel discovery" in substantially the same terms, as follows:

"It was recognized that the essence of this discovery lay in the variation of pressure at a point of contact between two electrodes in a galvanic circuit, thereby varying the resistance which such 'joint' offers to the passage of the current."

Again:

"The method of varying resistance by varying the pressure at a point of contact between electrodes, which was set forth in Berliner's caveat and subsequently in Professor Hughes' article, was instantly recognized as solving the problem of the 'battery-speaking telephone.'"

Again:

"Hughes says that he may use one contact (like two ends of wire) or a larger number of points of contact, and that he may use either metal or carbon contacts; the one essential thing being the 'difference of pressure at the different points of contact.' Berliner's caveat describes the invention as resting on variation of pressure at a point of contact between the electrodes, and says that the plate which forms one of the electrodes may be of any material, and that there may be more than one point of contact."

From these comparisons follows this conclusion:

"It cannot be seriously denied, and none of the witnesses deny, that the Hughes article and the caveat describe the same invention."

In this comparison of the Berliner and Hughes inventions it will also be observed that no mention is made of loose contact, or feeble contact, or light contact, and that, consequently, all of these descriptions are wanting in any reference to the essence of microphonic action. What Hughes disclosed to the world, as we have seen, was not varying the pressure at the point of contact; nor did the essential thing which he discovered lie in the difference of pressure at different points of contact. His discovery resided in loose contact, or rather

in the remarkable effects of sonorous vibrations in varying resistance at a loose contact. He also made loose contact between the electrodes the indispensable feature of his microphone. In describing that instrument in his article he says: "The form of the lozenge-shaped carbon is not of importance, provided the weight of this upright contact piece is only just sufficient to make a feeble contact by its own weight." He believed that these effects were due to pressure at the points of contact. This, however, was simply his theory of what took place,—his theory of microphonic action. Except in alluding to this theory near the close, the word "pressure," throughout the article, has reference to initial contact pressure. "Variation of pressure at a point of contact' may be descriptive of Berliner's invention, but, to say the least, it is a mistaken and misleading description of microphonic action and of Prof. Hughes' discovery.

Again, the first and most important claim of the Berliner patent fails to define the microphonic method of Hughes. The claim is for "the method of producing in a circuit electrical undulations similar in form to sound waves by causing the sound-waves to vary the pressure between electrodes in constant contact so as to strengthen and weaken the contact, and thereby increase and diminish the resistance of the circuit." It will be observed that the claim is silent as to the character of the initial contact between the electrodes. The claim must be read as if written April 14, 1877, a year before the Hughes discovery. With such knowledge of the telephonic art as existed at that time, no one would have known from this description of the Berliner method that the electrodes must be adjusted in a loose initial contact. In omitting any reference to loose contact, the claim fails to disclose the essence of the Hughes microphonic method.

The complainant has rested its case on the prior discovery by Berliner of microphonic action as disclosed by Prof. Hughes in his article of May 9, 1878. We are of the opinion that Berliner had no conception of this discovery, that he does not disclose such discovery in his caveat or patent, and that, if his transmitter operated as a microphone, it did so without any knowledge on his part of the microphonic principle. The world was left in the same ignorance of microphonic action after the appearance of his caveat as before. If Prof. Hughes had had lying on his table a Berliner transmitter and the Berliner caveat, they would have revealed nothing to him, nor have been of any assistance in the experiments which resulted in his discovery of the remarkable effects of sound waves in varying electrical resistance at a loose or feeble contact. If he had taken the diaphragm and metal ball of the Berliner instrument in place of the ends of his wire, he must have gone on experimenting with the effect of sonorous vibrations at different degrees of initial pressure between the plate and ball, until he had discovered that only with a slight pressure, or feeble contact, is there microphonic action. Prof. Hughes' discovery cannot be read into the Berliner caveat or the claims of the Berliner patent.

In connection with the invention set forth in the Berliner caveat, the complainant's experts dwell on "transition resistance," and the fact that such resistance varies enormously with pressure. "Transition resistance" is only another name for loose-contact resistance, or micro-

phonic resistance, and it was Hughes, not Berliner, who discovered transition resistance in the telephonic art, and the effects of sound waves in varying such resistance.

It was in its rebuttal testimony that the complainant fully brought out its contention that Berliner was the prior inventor of the microphone. In the opening testimony the complainant seemed to rely more upon the variable pressure theory of the Berliner invention. Prof. Cross, adopting Prof. Barker's language in the Government Case, defines the invention of the Berliner patent as "a transmitter whose operation was based upon the variation of electrical resistance by variation of contact pressure." Again Prof. Cross says:

"It is what is known as a variable pressure contact transmitter. It operates, not as did the magneto transmitter to generate the undulatory current produced by the small amount of energy which the voice can communicate to the transmitter, but simply to impress upon the electrical current furnished from another source—practically a battery—variations in strength which correspond to the motions impressed by the voice upon the transmitter. The current from the battery in flowing through the two electrodes (as they are called) of the transmitter, when these are set into vibration by the voice, is molded by their variations of pressure into a shape similar to that of the air vibrations of the air particles themselves; that is, it is molded into Mr. Bell's undulatory current."

"Pressure" and "variation of pressure" in the telephonic art usually refer to the effects of the movements of the diaphragm caused by sound waves at the contact between the electrodes. In every variable resistance transmitter the sound waves vibrate the diaphragm, and the movements of the diaphragm cause vibrations of pressure at the surface contact between the electrodes, which vary the resistance, and thereby reproduce speech.

"Variable pressure," however, in connection with the Berliner invention, is used by the complainant in a special sense. It signifies variations of pressure which vary the intimacy of contact between solid electrodes, and so vary the resistance, as distinguished from variations of pressure which vary the area of contact between a solid electrode and a liquid electrode, or the area of contact between two solid electrodes, or vary the compression of the mass between solid electrodes.

These distinctions may be further illustrated: If we cut the wire in an electric circuit, and place the severed ends in contact, it will be found that, by varying the pressure at the contact, the resistance will be varied, and consequently the strength of the current. This was a well-known fact in electrical science long before 1876. Here the variation of pressure may be said to vary the resistance by varying the intimacy of contact at the surface ends of the wire, although it is manifest that the varying pressure must also cause, in some slight degree, a varying area of contact. If, instead of two ends of a wire, we have one end of a wire and a liquid in constant contact, it is apparent that by pressing the wire down more or less, or by varying the pressure on the wire, the resistance will be varied, and consequently the strength of the current. Here variation of pressure may be said to vary the resistance by varying the area of contact, although the intimacy of contact also will be varied in some degree. Again, if in place of the two ends of a wire, or the end of a wire and a liquid, we have the end

of a wire and some compressible solid material, like plumbago, in constant contact, it is equally clear that by varying the pressure on the wire the resistance will be varied, and consequently the strength of the current. Here variation of pressure may be said to vary the resistance by varying the compression of the mass of material rather than by varying the intimacy of contact or area of contact.

Turning now to the telephone transmitter art, we find that none of these ways of varying resistance by varying pressure has advanced the art or made any impression upon it. These ways of varying resistance, and the difference between them, have been brought out and emphasized by the learned and skilled experts in the case at bar. These ways are simply the different modes of operation of the materials which compose the electrodes. They certainly cannot form the basis for any method patent covering all materials whose mode of operation is the same, because there is nothing in the so-called area varying method, or density varying method, or intimacy of contact varying method, considered by themselves and apart from the discovery of microphonic action, or the special properties of some material like carbon, which has ever contributed anything to the progress of the telephonic art.

The terms "pressure" and "variation of pressure," considered by themselves, are mere abstractions, and cannot involve invention. There may be instances, however, where an invention may be said to reside in the discovery of "pressure," or "variation of pressure," and their utilization in the telephonic art. For instance, Edison may have discovered that carbon or plumbago varied its resistance greatly under pressure; and, if this discovery were embodied in a telephone transmitter, the invention might be said to reside in his discovery of "pressure," or "variation of pressure," in a particular material. Again, some one might have discovered that the resistance varies enormously with pressure at a loose contact between electrodes; and, if this discovery were embodied in a telephone transmitter, the invention might be said to reside in the discovery of pressure, or variation of pressure at a loose contact. It cannot be said, however, that Berliner made any discovery of pressure or variation of pressure, which has proved of any utility in the art. His discovery, as we have seen, of the variation of pressure at a point of contact between metallic electrodes in a telephone transmitter possessed little utility and was practically worthless. It may have been an invention, in that he discovered that the minute vibrations of the diaphragm due to sound waves, by varying the pressure at the contact between metallic electrodes, as distinguished from other kinds of electrodes, vary the resistance and reproduce sound; but this is the limit of his invention, in the absence of any discovery of microphonic action springing from loose contact between the electrodes.

To summarize our conclusions respecting the variable resistance transmitter:

We find that Bell, in March, 1876, discovered that the minute atmospheric vibrations due to sound waves would cause the diaphragm to vibrate, which vibrations, by varying the pressure between a solid electrode and a liquid electrode in constant contact, produced

variations of electrical resistance, whereby speech may be transmitted.

We find that Edison, in February, 1877, discovered that the minute atmospheric vibrations due to sound waves would cause the diaphragm to vibrate, which vibrations, by varying the pressure between two solid electrodes of different conductivity in constant contact, one metallic and the other hard rubber covered with a plumbago film, produced variations of electrical resistance, whereby speech may be transmitted.

We find that Edison, on April 1, 1877, discovered that the minute atmospheric vibrations due to sound waves would cause the diaphragm to vibrate, which vibrations, by varying the pressure between two solid electrodes in constant contact, one metallic and the other compressible plumbago, produced variations of electrical resistance, whereby speech may be transmitted.

We find that Berliner, on April 14, 1877, discovered that the minute atmospheric vibrations due to sound waves would cause the diaphragm to vibrate, which vibrations, by varying the pressure at the point of contact between metallic electrodes in constant contact, produced variations of electrical resistance, whereby speech may be transmitted.

All of these discoveries, when embodied in transmitters, were inventions, but none of them was a commercial instrument, or solved the problem of a practical long-distance speech transmitter.

We find that, in the fall of 1877, Edison discovered the carbon electrode; that this discovery represents the first marked advance in the transmitter art since the 1876 Bell patent; and that the carbon electrode is found in every commercial battery transmitter.

We find that in May, 1878, Prof. Hughes discovered microphonic action, or the fact that sound waves produce remarkable variations of resistance at a loose or feeble contact between solid electrodes in constant contact, whereby speech may be transmitted; that the principle he then made known is utilized in every practical battery transmitter; and that he embodied his discovery in an instrument which he was the first to term a microphone.

We also find that Edison's discovery of the carbon electrode and Hughes' discovery of microphonic action solved the problem of a variable resistance transmitter, whereby speech may be transmitted long distances, and that both these discoveries are embodied in the defendants' transmitters.

We also find that the two claims of the Berliner patent in suit, although upon their face open to the objection of excessive breadth, may be sustained when read in connection with the specification, provided they are limited to metallic electrodes, and that, when so limited, the defendants' transmitters do not infringe.

Our conclusion is that the decree of the circuit court must be affirmed on the ground of noninfringement.

The decree of the circuit court is affirmed, with costs for the appellees.

LANYON ZINC CO. et al. v. BROWN et al.

(Circuit Court of Appeals, Eighth Circuit. November 10, 1902.)

No. 1,786.

1. PATENTS—CONSTRUCTION OF CLAIMS—ORE-ROASTING FURNACE.

The Brown patent, No. 471,264, for an ore-roasting furnace, claim 1, which covers a furnace in which the mechanism for operating the rabbles for stirring and advancing the ore is placed in a supplemental chamber for the purpose of protecting it from the action of the heat, dust, and fumes, was not anticipated, nor is it limited, by the Stanley patent, No. 61,577.

Appeal from the Circuit Court of the United States for the District of Kansas.

Albert H. Walker and John H. Atwood, for appellants.

Philip C. Dyrenforth, for appellees.

Before CALDWELL, and THAYER, Circuit Judges, and HALLETT, District Judge.

HALLETT, District Judge. This case was before the court at the last term on appeal from an order made in the circuit court granting an injunction pendente lite. The history and character of the case and its dependence upon *Metallic Extraction Co. v. Brown*, 104 Fed. 345, 43 C. C. A. 568, is fully stated in the review of the case at that time. (C. C. A.) 115 Fed. 150. At that hearing appellants assigned error upon the ruling of this court in the *Metallic Extraction Company Case* sustaining claim 1 of the Brown patent, No. 471,264, and put before the court a patent issued to William C. Munroe, No. 227,818, in support of that assignment. The Munroe patent was considered at length, and found to be very different from the Brown invention. Afterwards the case was carried to final decree in the circuit court, which sustained claim 1 of the Brown patent, No. 471,264, and declared that respondents, in constructing a Ropp furnace under patent No. 532,013, had infringed upon the Brown patent. The decree was entered July 3, 1902, and this appeal was taken from it.

At this hearing, error is again assigned upon the ruling of the court upon claim 1 of the Brown patent in the *Metallic Extraction Company Case*. Another patent, not heretofore considered by the court, is now put before the court to show that the former ruling was not correct. This patent, No. 61,577, was issued to I. N. Stanley, January 29, 1867. Figures 1 and 2, shown upon the opposite page, exhibit the form and structure of this device. The Stanley furnace is round, and it is described with reference to Fig. 1 on the opposite page in claim 1 of the patent as follows:

"An oven B, revolving arms F, F, and upright shaft K, operated by means of gears G, G, and horizontal shaft H, or their equivalents, substantially as described."

The inventor describes the manner of putting ore into the top of the furnace through the hopper L, in the figure in words following:

"The ore pulverized is placed into a hopper near the center of the furnace, and is conveyed through a tube of fire clay or other material of a refractory

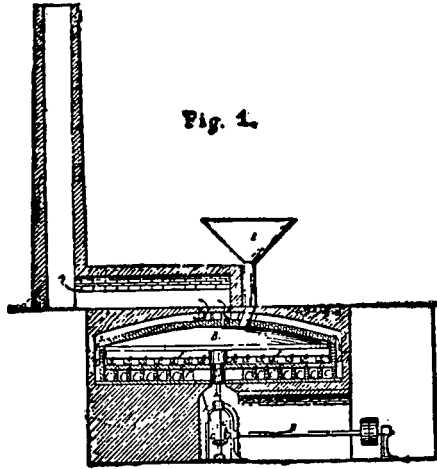
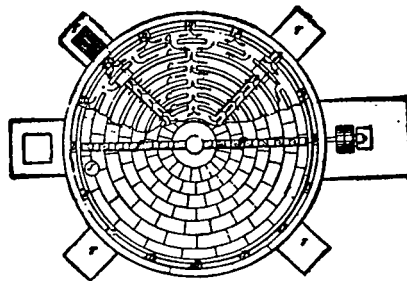

Fig. 1.

Fig. 2.



nature, near the center of the oven B, and is from thence conveyed in a circular manner from the center to the circumference, where it passes through an opening, J, into a receiver for amalgamation or other treatment."

The plows or rabbles of the Brown patent, by which the ore is stirred, are in the Stanley patent called carriers, and the ore is delivered into the furnace through them. Claim 2 of the Stanley patent reads as follows:

"2. I claim the conveying the ores or other material, while being operated upon, from the central part of oven B to the circumference, and there discharging them, or from the circumference to the center as may be desired, by means of conveyers A, A, connected to arms F, F, as shown on Fig. 5, substantially as described."

How the ores would be conveyed from the center to the circumference, or in the opposite direction, is not explained in the patent, but it may be assumed that this result might be obtained through some inclination of the hearth. Provision was made for reversing the rotary movement of the rabble carrying arms so as to protract the period of

roasting, and thus prevent the discharge of the ores from the furnace prematurely. A considerable part of the patent is devoted to the subject of introducing air through the shaft K and the rabble bearing arms for the purpose of keeping them cool and supplying oxygen to the furnace. Another subject of considerable importance in the mind of the inventor is a condenser located near the furnace, into which the gases of the furnace could be driven, and thence conveyed to furnaces marked T, in Fig. 2, to be used as fuel for heating the furnace. Nowhere in the patent is any claim asserted in respect to the power for driving the rabbles. On the contrary, the inventor uses this language in respect to the driving apparatus:

"* * * and in applying the power for the operation of shaft and conveyer arms, I do not confine myself to the arrangement of shaft below, as shown by Fig. 1, as it may be more convenient in some cases to apply the power from above; nor do I confine myself to the use of gears G, G, as it may be desirable to substitute a worm and gear instead."

No further description can be necessary to show the radical difference between the Stanley and the Brown patents in respect to the subject under consideration. In the Brown patent the problem to be solved was that of withdrawing from the furnace the rabble driving apparatus to a place without the furnace in which it would be less exposed to the heat of the furnace. In the Stanley furnace no such problem occurred or could possibly arise. The scheme and plan of that furnace embraced no more than the rotary movement of the rabbles and the arms supporting them within the furnace. For this purpose the inventor resorted to the simple device of beveled gears, used from the earliest times for converting horizontal into upright movement. The shaft through which the power was applied must necessarily be in the center of the furnace, and whether the means for turning the shaft should be applied from above or below, and in one way or another way, was a matter of convenience only. And so it seems to us that the chamber under the hearth of the Stanley furnace was not an essential part of that invention, and its location under the hearth or elsewhere is a matter of no significance whatever.

When we look to the nature and quality of the Brown and Stanley furnaces, the contrast between them widens as we proceed, until it becomes apparent that no feature of either of them has any bearing upon the other. The experts who testified at the hearing were unable to say that the Stanley furnace was ever used in a practical way, or that it could be made useful as its author intended. However that may be, it is plain that, under the rotary motion of the plows or rabbles, there was no forward movement of the ore on the hearth in the course of the furnace, as in the case of the Brown device.

In the first claim of the Brown patent, the furnace to which the invention is to be applied is described as a "furnace having means for stirring and advancing the ore." Brown did not invent the means here referred to, but he utilized such means by preserving the movement of the plows or rabbles in the course of the furnace which carried the ore forward to its destination. No such result is accomplished under the Stanley patent. Counsel for appellants says in his brief:

"The appellants do not contend that the Stanley patent negatives the validity of claim 1 of the Brown patent; but they do contend that it limits

that claim to an ore-roasting furnace, having its supplemental chamber at the lateral side of the main roasting chamber."

In our judgment the Stanley patent, though senior in point of time, has no effect whatever upon the Brown invention. The argument of counsel, often renewed in this court, that the first claim of the Brown patent was too broadly construed in the Extraction Co. Case, must be passed without consideration. As between the Brown and Ropp furnaces in controversy in this suit, which were also in controversy in the Extraction Co. Case, the question of the proper construction of claim 1 of the Brown patent is not open to debate in this court.

The decree of the circuit court is affirmed.

AUSTRALIAN KNITTING CO. V. WRIGHT'S HEALTH UNDERWEAR CO.

(Circuit Court of Appeals, Second Circuit. December 2, 1902.)

No. 58.

1. PATENTS—INFRINGEMENT—KNITTING MACHINES.

The Kinsey patent, No. 424,314, for a burr wheel for knitting machines, held not anticipated, valid, and infringed.

Appeal from the Circuit Court of the United States for the Southern District of New York.

For opinion below, see 115 Fed. 527.

George A. Mosher, for appellant.

W. P. Preble, Jr., for appellee.

Before LACOMBE, TOWNSEND, and COXE, Circuit Judges.

PER CURIAM. We are convinced that the proof fails to show prior use beyond reasonable doubt. The defense of laches has not been clearly established. It depends largely for its support upon inference and conjecture. The facts are capable of a construction consistent with due diligence on the part of the appellee. The stipulation entered into by counsel for appellant, in connection with the other evidence in the case, clearly establishes infringement. The only question which we regard as at all serious arises upon the Condé patent, but, after careful consideration, we are satisfied with the interpretation of the patent by the judge of the circuit court. Figs. 4 and 5 of the drawings, considered alone, may fairly be said to show the enlargement or cam attached to the blade. But there is nothing in the description to support such an interpretation. In fact, the language there used would seem to indicate that the enlargements used were the well-known filling blocks of the prior art. The claim, too, is in accord with this interpretation, as it speaks of the blocks as separate and distinct structures, namely, the "filling-blocks, c, arranged between the said two series of wings." Nothing further need be added to the opinion of the circuit court.

The decree is affirmed.

GENERAL ELECTRIC CO. v. WISE.

(Circuit Court, N. D. New York. January 17, 1903.)

1. PATENTS—INJUNCTION AGAINST INFRINGEMENT—DEFENSES.

That a defendant is able to respond in damages is no defense to an application for an injunction against infringement of a patent. If the patent is valid, the owner has the absolute right to be protected in the exclusive use of the invention which the law secures to him during the term of the patent.

2. SAME—VIOLATION OF ANTI-TRUST LAW.

That a complainant is a member of a combination in violation of the anti-trust law of July 2, 1890 [U. S. Comp. St. 1901, p. 3200], does not give third persons the right to infringe a patent of which complainant is owner, nor preclude complainant from maintaining a suit in equity to enjoin such infringement.

3. SAME—ANTICIPATION—PRIOR UNSUCCESSFUL DEVICES.

A patent for an invention which successfully accomplishes a useful result is not void, for anticipation or prior use, because of a prior device, however similar in combination or close in resemblance to that of the patent, where such prior device was not operative, and failed to produce the result sought, and which is produced by the device of the patent.

4. SAME—INFRINGEMENT—INCANDESCENT LAMP SOCKET.

The device of the Tournier patent, No. 559,232, for an incandescent lamp socket, was not anticipated by either the Weston socket or the Westinghouse push button socket, both of which failed to accomplish the result sought, and attained by the device of the patent. Claims 1, 2, 3, and 4 construed, and *held* valid and infringed, on a motion for a preliminary injunction.

In Equity. This is a motion in the above-entitled cause for a preliminary injunction restraining the defendant, his agents and servants, from manufacturing and selling certain electrical apparatus (sockets for incandescent lamps) alleged to be an infringement of the Tournier patent (letters patent No. 559,232), particularly claims 1, 2, 3, and 4 thereof,—a structure or invention alleged to be indispensable in the art of electric lighting.

Samuel Owen Edmonds, for complainant.

Alfred Wilkinson (William Kernan, of counsel), for defendant.

RAY, District Judge. The complainant's claim is: That prior to April 28, 1896, Julius C. Tournier, a citizen of the state of New York, residing at Schenectady, was the original, first, and sole inventor of certain new and useful improvements in sockets for incandescent lamps, fully described in the letters patent, No. 559,232, and which had not been used by others in this country before his invention or discovery thereof, and which had not been abandoned or patented or described in any printed publication in this or any foreign country before his invention or discovery thereof, or more than two years prior to his application for said letters patent, and which were not, prior to his said application, in public use or on sale in this or any other country for more than two years. That all lawful conditions having been complied with, on the 28th day of April, 1896, letters patent, in due form, were duly issued therefor to the said Tournier;

¶ 1. See Patents, vol. 38, Cent. Dig. § 495.

complainant, General Electric Company, being the assignee of said Tournier. That by virtue of such patent and assignment the complainant became and is vested with and possessed of the full and entire right, title, and interest in and to said letters patent, and all rights thereunder, and was in the full possession and enjoyment of same up to February, 1899. That the complainant is a large manufacturing company, engaged in manufacturing and putting sockets for incandescent lamps, employing and containing such invention, on the market and in the trade, and that same are being generally used, and that such sockets so made, sold, and delivered have been duly marked "Patented," and that complainant has invested large capital in the business, and been to great expense and trouble in establishing the business, and that such sockets are in great demand, and complainant will reap great benefits if the alleged infringement by the defendant is enjoined, and suffer great loss if an injunction is not granted. That in the spring of 1899, the Anchor Electric Company undertook to and did infringe said letters patent. That this complainant brought suit against said company for said infringement in the United States circuit court for the Southern district of New York, and that an answer was filed alleging the invalidity of said patent by reason of anticipation in the prior art, and that the production of such structure did not involve the exercise of invention, and also denying that the sockets made and sold by said Anchor Electric Company constituted an infringement. That proofs were taken, the action tried and duly submitted, and a decree duly made and entered fully establishing the validity of such patent. The final decree was made January 24, 1902. Another suit and decree of similar or the same import against New England Electric Company are also alleged. It is then alleged that the defendant, well knowing all such facts, without license or allowance and against the will of the complainant, has made and sold, and is making and selling, or causing to be made, used, and sold, sockets for incandescent lamps, employing and containing the said invention, and particularly those set forth in claims 1, 2, 3, and 4 of said letters patent, and is threatening to continue such infringement; that said defendant has been notified of such infringement; and that his continuance of such acts encourage others to infringe likewise.

The defendant claims that this invention was old,—prior invention,—and relies on the Weston socket and the Westinghouse push button socket, and says he has not infringed, and that his block differs more from Tournier's than Tournier's does from Weston's. The defendant then alleges that the complainant does not come into court with "clean hands"; that it and all other important socket manufacturers in the country organized an illegal association three or more years ago, by the terms of which they bound themselves to raise the price of sockets, and not to sell at a lower price than agreed, in direct opposition to the anti-trust law of July 2, 1890 (26 Stat. 209 [U. S. Comp. St. 1901, p. 3200]). By implication, rather than directly, it charges collusion between the complainant and Anchor Electric Company in the action referred to, and finally says no injunction should be granted, because the defendant is a leading manufacturer of Watertown, N. Y., amply able to respond in damages, and that the com-

plainant should resort to that remedy even if this court finds an infringement.

No time will be used in answering this suggestion, except to say that, if the complainant's letters patent are valid, it is entitled to protection by injunction against all the world. No other person or company can use its property of this description without its consent, and relegate it to an action for damages. If this patent is valid, the complainant has the absolute right, under the laws of our country, to the use of the patent, and to designate the parties upon whom it will confer the right to use it. Again, in such a case, an action for damages does not afford an ample or a full and complete remedy. Such a remedy is inadequate. In a sense, the granting of a patent confers a monopoly on the inventor or owner of such patent, but such a monopoly is granted in the interest of the public as well as of the grantee of the patent, and is an encouragement to the development of inventive skill and genius. The patent laws of the United States, while sometimes abused or perverted, have had much to do with the growth and prosperity of our country, and have added much to our material and intellectual development. Ultimately, these inventions are surrendered to the public, and it is only just that for a time the inventor reap the rewards of study and industry. *Grant v. Raymond*, 6 Pet. 218, 241, 8 L. Ed. 376; *Bement v. Harrow Co.*, 186 U. S. 88, 89, 22 Sup. Ct. 747, 46 L. Ed. 1058. The cry of monopoly, therefore, has no place in the discussion of the question of infringement or priority of invention. It is difficult to understand how or why a violation of the Sherman anti-trust law by this complainant, if there has been such a violation, confers any right on the defendant to infringe this patent. That act points out the penalties for its violation, and it is not understood that such law denies the grantees of patents the protection of the law because they may be violating some statute. However that may be the evidence falls far short of establishing such a violation by this complainant. The testimony on that subject is squarely contradicted. An individual cannot confiscate the property or property right of a corporation on the ground it has violated that act. *Soda Fountain Co. v. Green (C. C.)* 69 Fed. 333; *Columbia Wire Co. v. Freeman Wire Co. (C. C.)* 71 Fed. 302; *Bement v. Harrow Co.*, 186 U. S. 70, 88-91, 22 Sup. Ct. 747, 46 L. Ed. 1058. *Harrow Co. v. Quick (C. C.)* 67 Fed. 131, cannot be accepted as authority on this question.

We come then to the consideration of the questions whether this Tournier patent, No. 559,232, issued April 28, 1896, is a new and valid invention, and whether the defendant has infringed and is infringing same.

Claims 1, 2, 3, and 4 of the said patent, now particularly in question, are as follows:

"(1) In an incandescent lamp socket, an insulating block, circuit terminals, and a circuit-controlling key, with a metallic tip and operating spring mounted thereon, in combination with a metallic socket mounted on the insulating block; the metallic tip of the controlling key being adapted to make contact with the shell and close the circuit.

"(2) In an incandescent lamp socket, as a new article of manufacture, an insulating block, formed with passages in its edges for the circuit wires, a

transverse passageway for the insertion of a controlling circuit key shaft, its bearings, and a controlling spring, a cavity at one end for the location of a rotary metallic tip of the key shaft, and a cavity at the other end for the location of one of the binding screws and brackets, a cavity at one side of the block for the location of the other binding screw and bracket, and a contact arm as herein set forth.

"(3) In an incandescent lamp socket, an insulating block, formed with a transverse cavity, a rotary circuit-controlling key, and a spring and contact tip located in this cavity, binding screws located in cavities in the insulating block, one connected with the key shaft and the other with a metallic contact arm projecting over the top of the block, and a shell or socket mounted on the top of a block, and adapted to complete the circuit with a lamp by contact of the contact tip therewith.

"(4) In a socket for incandescent lamps, the combination with the insulating base thereof and a key having a contact tip of a lamp-socket cylindrical shell mounted on one end of said base, and so arranged in relation to the key tip that the latter contacts with the lamp-socket cylindrical shell to close the circuit, as set forth."

In *General Electric Co. v. Anchor Electric Co. (and Henry G. Issertel as agent and manager of said company)*, reported (C. C.) 106 Fed. 503, the validity of this patent,—particularly of claims 1, 2, 3, and 4, above quoted, and also claim 9, was directly in issue; and it was held by Shipman, Circuit Judge, after full and careful consideration:

"The Tournier patent, No. 559,232, for a socket for incandescent lamps, the base of which consists of a substantial block of porcelain or other insulating material, in which the contact key and circuit terminals are incased, covers a device which, as a complete structure, was not anticipated, and, in view of its immediate general adoption and commercial success, cannot be denied patentable invention. Claims 1, 2, 3, and 4 construed, and held infringed. Claim 9, which is limited to an insulating ring, used between the outer shell and the socket, held void for lack of invention, in view of the prior art."

In that decision, as far as it covers the precise questions now presented, this court fully concurs. It is not necessary to travel over the same ground, and present the same facts and reasoning in different language. But the respondent here, James B. Wise, as he alleges, raises new questions, and presents new evidence, upon which this court is asked to find and hold that this invention, covered by the claims quoted, was anticipated and not patentable, and, failing here, claims the defendant's socket is as much or more a new invention as the complainant's, and that same is so widely different as not to constitute an infringement. The defendant says:

"We oppose this motion on new evidence of the highest importance, and offer entirely new defenses: First. On the Weston socket, having a cylindrical block of insulation, identical in every essential with Tournier's, for it has the transverse passageway, the outside cavities, and the wire grooves or passages in its edges. Second. On the Westinghouse push button socket, in public use and on sale in 1893 and before, which shows a porcelain block of similar construction, having a transverse passageway to receive and to protect the switch mechanism."

It is not discovered from the record that Judge Shipman had these two sockets, or a description of them, before him when he passed on the question of anticipation or prior invention and use. This alleged new evidence will be considered on the theory that it was not presented to the court on the trial of the *Anchor Electric Co. Case*, and might have changed the result there, and may change the result here from

what it necessarily would be, should this court follow the decision of Judge Shipman.

Two or more persons may use the same material, existing in precisely or substantially the same form, experimenting and making combinations, and having in mind the construction of a new and a useful invention that will produce a given result. The one or ones who fail invent nothing, but the one who succeeds may have invented a patentable thing; and, if a patent is granted, he is entitled to its protection and benefits. Those who failed, or others, cannot, by taking the same materials and making substantially the same combinations, varying the form or arrangement, or both, in nonessentials, but aiming at and producing the same results, claim either priority of invention, prior use, or new invention. Such facts will not defend the charge of infringement. And even if in such experimentation certain imperfect results were obtained, that fact does not establish priority of invention. "If the patented invention is not operative, it cannot be infringed by one that is." *Royer v. Coupe* (C. C.) 29 Fed. 358, 39 O. G. 239. It would seem to follow that however close the resemblance between some prior alleged invention, even when put in actual use, and the patented invention, if such alleged prior invention was not operative, and failed to produce the beneficial results sought and produced by the patent, it could not constitute prior invention. In such case the patented invention cannot be regarded as old.

In *General Electric Co. v. Anchor Electric Co.*, supra, Judge Shipman says:

"The insulating block of the patent, as constructed and arranged to become the receptacle of the various metallic parts, was a novelty, and in its peculiar characteristics it had no predecessor."

It is now insisted that the Weston socket and the Westinghouse push button socket are each substantially identical with the Tournier socket, and that therefore the Tournier insulating block had not one, but two, predecessors. A careful examination of both, and a comparison of the Tournier block with the Weston block, not only fail to disclose identity, but even similarity, when we consider the purposes for which devised, and the ends to be accomplished. Both are, in general form, cylindrical. Each has a transverse passageway, but these are neither identical, nor, mechanically speaking, similar. The differences in the two are marked and well defined, and absolutely essential differences. They are so marked that it does not occur to the observer that the designer of the Tournier block had the Weston block before him, or in mind, when planning his. In the Tournier block the transverse passageway gives neither ingress on the one side, nor egress on the other, to its full depth. At one side this passageway is so widened as to form a chamber on either side of the main passageway, while at the other side a part of the block is entirely cut away for about one-third the diameter of the block, and to a depth within one-eighth or one-fourth of an inch from the bottom of the transverse passageway. Upon one side a recess is cut, which reaches to within about one-eighth of an inch of the passage referred to. There are other peculiarities, not necessary to describe, but all these peculiarities have their necessary uses in the assembled socket. In the Weston

block, which was of wood, the transverse passageway extends from circumference to circumference unbroken, is much wider, is of uniform width from circumference to circumference and of uniform depth, giving ingress and egress to its full depth, and on one side is cut through to the bottom. Upon the outside of the cylinder we find no less than eight grooves and recesses vertical and diagonal for the arrangement and application of the electrical appliances, none of which are found in the Tournier block. When we come to consider the mode of using these blocks, the ideas of means of application and use, and the results, we find that the functions are not the same, the modes of operation are radically unlike, the results not the same, and the ideas of means for the accomplishment of satisfactory results are radically different, or at least radically defective, in the assembled Weston socket. The Weston socket was not satisfactory or even safe. The Tournier device was carefully and skillfully wrought out by a change in the character of the insulating base, as well as by the modes of working the same, and also in many minor details and appliances, all brought into harmony and harmonious action, and producing satisfactory results, at which many had aimed, but which all had failed to accomplish. It is impossible to find that the Weston socket was, in a legal sense, as applied in these cases, the predecessor of the Tournier socket.

Coming to the consideration of the Westinghouse push button socket, we find far less resemblance and similarity. It is not necessary to go into detail. In both the Star and Weston sockets, the metallic switch mechanism, which is in the circuit where the current of electricity is being fed to the lamp, is arranged in a cavity or a passageway on the underside of the block, and consequently there is no solid insulation between these electrified parts and the metallic supporting cap of the socket. The result of this, or one result, is the tendency to short-circuiting and burning out, and the resulting fire hazard. In the Tournier socket, the metallic switch mechanism is arranged in a passageway on the upper side of the block, and we have a solid wall of insulation interposed between these electrified parts and the supporting cap of the socket. Short-circuits and burning out are thus precluded between such parts and the cap. In the Tournier socket, we find the contact key and circuit terminals encased within the base, and accidental contact with the exterior metallic shell is thus prevented. In the Weston socket, one of the terminals—one of the parallel contact strips on the block (and this corresponds to the screw shell element)—is always in the circuit and electrified, whether the lamp is in place and the current turned on or not. Here is found, again, the evil of short-circuiting, with outside metallic bodies, and also a liability to accidental shock when handling the socket and when replacing or removing the lamp. With the Tournier socket, all this is remedied, as the situation is the reverse. Again, in the Tournier structure we find the threaded shell disconnected from the circuit except when the lamp is in place or the key closed. To bring about these results, necessary to the success of the art, required inventive skill. The Tournier structure accomplished what all others had failed to bring about, by new ideas of means, by the use of new means, or, to some

extent, old appliances improved, applied, and combined in a new and an effective and beneficial way.

We come, then, to consider the alleged infringement. Each and every essential element of the Tournier patent, as described or mentioned in the claims quoted, or its exact equivalent, is used by the defendant in what we will term the "Wise Socket." Placing the various appliances, making up the assembled sockets, side by side, and then taking the assembled sockets as a whole, we find that there is no substantial difference, except in the mere form of two or three of the parts. In short, the Wise socket is a copy of the Tournier. The compared sockets perform the same functions by the same modes of operation. The effects are the same; the modes of operation are the same, substantially; and the same is true of the means employed. In some respects we find variations in size, shape, and arrangement, but these are evidently studied, not for the sake of improvement, but to avoid the charge of infringement. The socket of the Anchor Electric Co. held to be an infringement, and therefore enjoined (106 Fed. 503), differs but slightly from the Wise socket, here in question. The defendant here, in some respects, has varied from the Anchor Electric and New England infringements, but in so doing has made the similarity of his socket to the Tournier patent the more apparent. In some respects he has varied the form of the insulating block by changing the location, size, and shape of certain cavities and grooves; but all these changes are immaterial, as they do not change the principles of operation, the means, or the results, and the claims of the Tournier patent (referred to and here in question) do not confine the complainant to any precise form or size. The combinations in the assembled socket do not present any substantially different combination. As stated, the combinations are substantially identical. So far as there has been a substitution of elements, they were well-known equivalents. The defendant has produced this Wise socket extensively and secretly. He claims the right to continue its manufacture and sale. Unless enjoined, he will do this, and most seriously injure the complainant. This injury cannot be measured satisfactorily by any judgment for damages, even if the defendant shall be found responsible at the end of the protracted litigations sure to follow a denial of this application.

The conclusion is that, until the trial and determination of this action, the defendant should be enjoined as prayed. It is so ordered.

OTIS ELEVATOR CO. v. PORTLAND CO.

(Circuit Court, D. Maine. January 14, 1903.)

No. 526.

1. PATENTS—INFRINGEMENT—ELEVATOR CONTROLLING MECHANISM.

In the Bassett patent, No. 453,955, for an elevator controlling mechanism, claims 1 and 2 cannot be given a broad construction as embodying a generic invention, since, in that case, if not anticipated, they would cover the device of the prior patent, No. 359,551, to the same patentee, and would be void for double patenting, and the invention of the later patent must be restricted substantially to the specific combination shown in claims 3 and 4. As so construed, claims 1 and 2 held not infringed.

In Equity. Suit for infringement of letters patent No. 453,955 for an elevator controlling mechanism, granted to Norman C. Bassett June 9, 1891. On final hearing.

Edwin H. Brown, for complainant.
Payson & Virgin, for defendant.

HALE, District Judge. This bill in equity is brought for infringement of United States patent No. 453,955, dated June 9, 1891, for an improvement in elevator control mechanism invented by Norman C. Bassett. It is claimed that the infringement by the defendant is upon the first and second claims of the patent, so that only those claims are in issue. They are as follows:

"(1) A device for operating the stopping and starting mechanism of an elevator, consisting of two cables or cable-sections hanging in the well, adjacent to the path of the cage, from fixed supports at the upper ends, and both connected with the stopping and starting mechanism, and a single cable-operating device carried by the cage and arranged to bear upon both cables or cable-sections to tighten or slacken the same alternately to shift said mechanism to its different positions, substantially as set forth.

"(2) In controlling devices for elevators, the combination of a car, two fixed or standing cable-sections, each connected with a fixed support at one end and at the other with the starting and stopping mechanism, a cable-operating device on the car bearing on both cables and over which said cables pass, and means for moving said device to alternately take up and pay out the cables to shift the operating mechanism, substantially as described."

It is contended by the complainant that the inventor, Bassett, was the first to produce an elevator mechanism characterized by a single cable-operating handle arranged in operative connection with two cables or cable-sections at all times, and that he thus made a primary, generic invention. It is contended, further, that the Bassett patent should have the broad construction of a primary patent, and that under such construction of claims 1 and 2 the defendant's mechanism is an infringement. It is further insisted by the complainant that a distinctive feature of this patent is that it enables the operator in the cage or elevator, by a single hand device within the cage, to simultaneously tighten one cable and relax the other, and that this simultaneous control of both cables is new, and the proper subject of a primary patent; and, further, that while in the two claims at issue the element of simultaneity is not, in terms, expressed, still by a reference to the specification and the drawings, and also to the history of the prior art, it is evident that the patentee intended to claim this element as an important and leading one in his patent. This contention is put succinctly by the complainant's expert that "the claims are broadly for any device combined with the standing cable whereby one is positively paid out when the other is taken up." It is contended, on the other hand, by the defendant, that the two claims in suit should not receive the broad construction claimed by the complainant; that all the novelty in his patent was in the forms and the combination as constructed and put together; that such combination was of old elements, previously found in various forms and in different patents, and that anybody else has an equal right to again reshape and rearrange those old elements into another and

different combination; that, if the two claims are given the limited construction urged by the defendant, there has been no infringement by the defendant; that the real inventive force of the patent is found in the third and fourth claims, which are for a new combination of old elements, and that the first and second claims of the patent were put in merely as large dragnet claims, with the general view of attempting to get the benefit of other and different elevator mechanisms. The specific defenses made by the defendant are that the two claims in suit, if given the broad significance contended for by the complainant, were anticipated by several old patents; that all the elements set forth in those claims lacked novelty when taken separately, and it is only by the combination of such elements as are set forth in claims 3 and 4 that novelty can be found in the patent; that, in view of the prior art, Bassett's invention, if given the broad construction urged by the complainant, constituted only an aggregation, and not an invention; that the complainant's patent is invalid in view of an earlier patent of Bassett for the same invention, or that, if the patent in suit can be given any validity, it must, in view of the earlier patent, be given a limited construction, and be confined to claims 3 and 4; and that, if given this construction, the defendant's controllers are not in any way an infringement of the patent in suit. The defense is further made by the defendant that the patent in suit expired September 26, 1902, by reason of the expiring at that date of a British patent for the same invention, recited in the Bassett specification; so that, even if the patent in suit were valid, and had been infringed, there could be no decree for an injunction.

When we examine the history of the prior art, we find that the Otis patent, No. 131,896, dated October 1, 1872, shows two suspended cables fixed at the top, the same as in the Bassett patent; also means of tightening the cables by devices controlled by a duplicate hand device, and a further means of tightening these cables by a spiral. The single-hand device does not appear in the Otis patent. The history of the prior art shows also the Whitlock patent, No. 158,613, dated January 12, 1875. This patent shows the standing cables and the single hand controller with any "stopping and starting" mechanism. The hand controller seems to be in principle the same device as that claimed in the patent in suit. In the operation of the machine invented by Whitlock there is alternate action of the hand controller upon the cables, but no perfect simultaneous action upon the cables, as is claimed for the machine of the patent in suit, and as is found in a cruder form in the Otis patent. The Whitlock and the Otis patents do not appear to have ever been put in actual use, but it is urged by the defendant that they show all the elements that are in the Bassett patent; that the Otis patent shows all these elements except the hand controller, and that the Whitlock patent has all these elements, including the hand controller. The Reynolds patent, No. 317,202, shows running or traveling cables with a single device on the car. It is contended by the complainant that the force of the argument in regard to anticipation of the Reynolds patent is broken by the fact that, although his letters patent are previous to the date of the letters patent in suit, still the invention of the letters

patent in suit was in 1884, previous to the Reynolds patent, so that the invention of Bassett antedates the invention of Reynolds. Upon this point—namely, that the invention in the patent in suit was made in June, 1884—we find the patent of Baldwin, No. 390,053, dated September 25, 1888; the patent of Prince, No. 335,239, dated February 2, 1886; the patent of Perkins, No. 349,175, dated September 14, 1886; the patent of Stokes, No. 469,984, dated March 1, 1892. These patents of Baldwin, Prince, Perkins, and Stokes are all prima facie anticipations of the patent in suit, and it is substantially admitted that they are such anticipations, unless the invention of Bassett can be carried back to June, 1884. A serious question of fact is raised by this contention of the defendant as to whether the complainant has offered evidence sufficient to prove satisfactorily that Bassett's invention was actually made in the broad form contended for by him in June, 1884. The history of the art also shows further the old single cable elevator control mechanism in use for many years, and modified by the Hanford patent, No. 134,273, dated December 24, 1872. The history of the art shows also a patent by Bassett himself, applied for June 22, 1885,—No. 359,551. This patent is referred to by Bassett in the specifications of the patent in suit as follows:

"I am aware of the construction shown in my letters patent No. 359,551. In which there is shown an operating device in which two double grooved wheels are employed, the same being one species under the invention herein claimed, and differing practically from the construction herein shown in the liability of the cables to slip on one or other of the double grooved pulleys, thereby causing a wear that is avoided when each pulley can turn independently."

It is urged by the defendant that the patent in suit is invalid in view of this earlier patent, No. 359,551; that, if the invention of the patent in suit is given the broad construction claimed for it, it is clearly covered by the invention of patent No. 359,551, and is made void by it, under the authority of *Miller v. Eagle Mfg. Co.*, 151 U. S., page 199, 14 Sup. Ct. 310, 38 L. Ed. 121. It is claimed by the complainant that Bassett first invented his broad patent in June, 1884, and that this patent included the use of four stationary pulleys in controlling the two cables; that afterwards he invented the double pulley of patent No. 359,551, and applied for a patent upon same; that he then found that this double pulley was liable to cause a slipping of the cable, and he therefore applied for the use of the four pulleys in the patent in suit. If the patent in suit is given a limited construction, and is confined substantially to claims 3 and 4, it does not include the invention in patent No. 359,551; but, if claims 1 and 2 are given the broad construction claimed by the complainant, it is urged that this would clearly include the invention shown in No. 359,551, and hence would come under the law of double patenting, and, under the doctrine of *Miller v. Eagle Mfg. Co.*, would be invalid.

It is now necessary to inquire what breadth should be given to the claims for the Bassett patent in suit, to see whether or not, under the test applied by the court in *Machine Co. v. Lancaster*, 129 U. S. 273, 9 Sup. Ct. 299, 32 L. Ed. 715, this patent can be held to be an invention of a primary character, and whether the mechanical

functions performed by the invention can be held to be entirely new. It is necessary to examine the history of Bassett's invention, to follow the path which the mind of the inventor took in reaching the result achieved by this patent. Some time before March, 1885, Bassett made the invention contained in patent No. 359,551. The claims of that patent are as follows:

"In an elevator, a cage, a valve device, two freely turning sheaves or pulleys carried by the cage, a lever on the cage connected to vibrate the bearings of said pulleys, and two suspended ropes secured to fixed supports, passing in opposite directions around said pulleys, and connected to the valve device, substantially as described.

"(2) The combination with an elevator engine, a cage connected to be operated thereby, and valve devices, of two suspended ropes secured to fixed supports, a lever carried by the cage, and supporting double grooved pulleys outside the latter and adjustable from within the same, the said ropes being passed around the pulleys in opposite directions, and each connected at its end to a part of the valve-operating device, substantially as set forth.

"(3) The combination of the cage of a hydraulic elevator, a shaft extending through the side of the same and carrying levers at its opposite ends, sheaves carried by the arms of the external lever, a pulley near the bottom of the well, a rope fixed at the upper end passing around the sheaves and around the pulley within the well to the valve-operating appliances, and a second rope fixed at one end passing around the same sheaves and to the valve-operating appliances, substantially as set forth.

"(4) The combination of two suspended ropes secured to fixed supports connected to the operating valve of a hydraulic elevator, an adjustable lever supported by the cage, and two sheaves carried upon the lever, around both of which sheaves both the said ropes are passed, substantially as specified.

"(5) The combination, in an elevator, of a lever pivoted to the car, and having arms projecting therefrom, pulleys or sheaves carried by the arms, and two cables suspended at their upper ends from fixed supports, and passing round both of said sheaves to devices connected to the engine valve, substantially as described."

It will be seen that in claim 2 his description is of a "lever carried by the cage and supporting double grooved pulleys outside the latter, adjustable from within the same, the said ropes being passed around the pulleys in opposite directions, and each connected at its end to a part of the valve-operating device." The history of the art appears clearly to show that the specific structure described by these claims was novel. These claims do not indicate that the inventor then claimed that he was anything more than an improver upon a prior machine, which was capable of accomplishing the same general result; in which case his claims would not receive a broad interpretation. This patent is pronounced by the complainant's expert as commercially impracticable. That expert testified that the use of double grooved pulleys is impracticable commercially.

The figures of the patent in suit, namely, Figs. 1 and 2, which set out the only machine the defendant can be held in any way to infringe, are not made a part of this patent No. 359,551. Bassett further produced another specific patent in 1891, of which he says he made a sketch in June, 1884, and that patent is No. 456,463. He says he made some exhibition of this, and thought it inferior to No. 359,551. This contains the identical drawings of Figs. 3, 4, and 5 of the patent in suit. The claims of this patent No. 456,463 are as follows:

"The combination of the two cable-sections hanging in a well and connected to fixed supports and with the stopping and starting mechanism of an elevating engine, a cage provided with a single hand device, guide pulleys carried by the cage, and shifting pulleys connected to be shifted by the hand device, the cable-sections passing around the guide pulleys and shifting pulleys, and all arranged to draw upon one cable-section and relax the other by a single movement of the hand device, substantially as set forth.

"(2) The combination of a cable having two sections suspended within a well from fixed points and connected to operate the stopping and starting mechanism, a hand device, and two pairs of guide-pulleys carried by the cage, and a lever or arm carrying two pulleys and connected with the hand device within the cage, each cable-section passing over one pair of guide pulleys and around one of the pulleys carried by said lever, substantially as described.

"(3) The combination, with the cage and stopping and starting device, of two standing cable-sections suspended in the well, an operating device upon the cage bearing upon both cable-sections, and a lever connected with the cable-sections and the stopping and starting device, substantially as set forth."

In this patent the four separate pulleys on the lever of the patent in suit are not found. The four stationary guide pulleys on the car and only two moving pulleys on a vertical lever do not in any way point to a machine having no stationary guide pulleys and four moving pulleys. There is not evidence sufficient to lead the court to the conclusion that Bassett ever, before the fall of 1886, made any invention or any other structures than those described in the two patents above referred to, No. 359,551 and No. 456,463. Now, the machine described in claim 4 of the patent in suit is shown in the device in Figs. 1 and 2. Nowhere in the above two patents is there any description which conforms to those two depicted devices, or to claim 4 of the patent in suit. It does not appear that there were ever complete drawings, like Figs. 1 and 2, until the winter of 1886 and 1887. The patent solicitor and expert appears to have received the exhibit drawing for the patent in suit in September, 1886, which drawing shows no structure like Figs. 1 and 2, but does show Figs. 3, 4, and 5. These latter figures have never been embodied or used. Nothing valuable has ever been produced, except that described in the clear, specific device of Figs. 1 and 2.

The patents of Baldwin, Prince, Perkins, and Stokes are admitted to be anticipatory of the broad claims of the Bassett patent, unless they are prevented from such anticipation by the fact that Bassett's patent should date from the alleged time of his invention in June, 1884, instead of from the time of his application in October, 1886. The burden is upon the complainant to prove that his invention should date from the earlier date. Bassett seeks to overcome the presumption against him by his own testimony that Figs. 3, 4, and 5 of his patent were sketched by him in June, 1884, and disclosed to Reynolds in August, 1884; that immediately after, he made additional sketches like Fig. 1 of the patent in suit. There is no evidence, beyond this statement of Bassett, that immediately afterwards he made sketches like Fig. 1, except what Reynolds testifies; but Bassett disclosed Figs. 3, 4, and 5 to five persons, and does not claim that he so disclosed Fig. 1. He says that all his sketches were

abstracted from his desk in November, 1884; that in November he reproduced sketches of 3, 4, and 5, but not Figs. 1 and 2, because he then thought that patent No. 359,551 was the most commercial, and because from the drawing in that patent he could explain Figs. 1 and 2 by simply imagining the two double grooved pulleys to be split into four single pulleys; and he thought that a separate drawing was not required to illustrate the difference. He does not undertake to say that he made further drawings of Figs. 1 and 2 until the winter of 1886 and 1887. Reynolds cannot be said to have sufficiently corroborated Bassett as to his drawings of Fig. 1, nor is there any sufficient corroboration. We do not find enough testimony in the case to overcome the presumption against the complainant on this point, and to carry the invention back to June, 1884. If the invention is not so carried back to June, 1884, the patents of Baldwin, Prince, Perkins, and Stokes are clearly and admittedly anticipations of the Bassett claims 1 and 2 in suit.

We come now to the claims of the patent in suit. Claims 1 and 2 are already quoted above. The other claims, 3 and 4, are as follows:

"(3) The combination of a cage, a cable having two suspended sections, a shifting-bar connected with both parts of said cable-sections at the bottom of the well, and a cable-operating device carried by the cage bearing on both cable-sections, and provided with a single hand device within the cage, substantially as described.

"(4) The combination with the two cable-sections suspended within the well, and with a stopping and starting mechanism connected with said cable-sections, of a cage, a single hand device carried thereby, and a cable-operating device connected with the said hand device, and consisting of a lever carrying grooved pulleys at the opposite ends, each cable-section passing below one pulley and over the pulley at the opposite end of the lever, substantially as set forth."

Claim 4 has already been referred to. It covers the device described in Figs. 1 and 2. Claim 3 shows a shifting bar connected with both parts of the cable sections, as shown in the drawing and in the structure. These claims are clearly for specific apparatus. In claims 1 and 2 what does "tighten or slacken the same alternately" mean? The learned counsel for complainant suggests that it means, when taken in connection with the history of the art and with the drawings in the case and the models, that when one handle is moved in either direction it will take up one cable and pay out the other to the same extent only, thereby utilizing the latter as a hold-back. In other words, that "alternately" must have practically the meaning of "simultaneously." Undoubtedly, the machine may be operated so as to make simultaneity a very important element, but we do not find that there is anything in the patent in suit to show that simultaneity of action of the cables was intended to be a part of the invention. The claim calls for "means for moving said device, to alternately operate the cables," but not necessarily to do this simultaneously. It is urged with some force by counsel for the defendants that there is just as much reason for reading into claims 1 and 2 a requirement that the fixed supports of the cables should allow of no "give," or that the moving pulleys should swing through arcs of circles, as for reading into them the requirement that the

movement of one cable should always be accompanied by the movement of its mate. It is perfectly true that no one of these three limitations is made in the patent, even when that patent is construed in the light of the history of the art, of the drawings, and of the models. To interject "simultaneity" into the patent as a necessary element would be to make interpretation take the place of invention. If this simultaneous element is not interpreted into the patent, it seems clear that there has been anticipation to some degree by Otis, and substantially by Whitlock. It is to be remembered that the patent in suit was applied for in October, 1886, after patent No. 359,551. The element of looping and simultaneity of action are as true of No. 359,551 as of Figs. 1 and 2 of the patent in suit. About the only difference between the functional action of the two patents is found in the fact of the latter patent, namely, the patent in suit, cutting the two pulleys, and making four of them. This is not the case, often shown under the patent law, of the inventor of a broad novelty, capable of various specific embodiments, applying for a broad patent, and afterwards applying for patents on specific forms.

It is well urged by the defendant that, if the element of looping cables simultaneously affected by the hand device is to be interpreted into the patent in suit, it should be so interpreted also into No. 359,551. In other words, if simultaneity is allowed to inhere in the patent in suit, and so enable the court to differentiate this patent from the Whitlock patent, then it must be found that this same element of simultaneity, being found in No. 359,551, as well as in the patent in suit, makes a case of double patenting, under the doctrine of *Miller v. Eagle Mfg. Co.* It cannot be that courts can hold that merely splitting two double grooved pulleys into four single grooved pulleys is such a change as to constitute invention, much less to allow the court to interpret the patent in suit into a broad, generic patent. From an examination of the forms of the defendant's controllers, as shown by the record, it seems clear that, if claims 1 and 2 include these controllers, they are also broad enough to include the invention of Whitlock; and that thus Whitlock's patent must be held to be anticipatory of the broad claims 1 and 2 of the patent in suit. Claims 3 and 4 constitute a working species patent, and do not cover the invention of the earlier patent, No. 359,551. They are a separate invention from this earlier patent, substantially different from and independent of it. They are the taking of old elements, and combining them in a new and useful way, as in *Dowagiac Mfg. Co. v. Minnesota Moline Plow Co.* (C. C. A.) 118 Fed. 136.

In *Miller v. Eagle Mfg. Co.* the court says:

"No patent can issue for an invention actually covered by former patents, especially to the same patentee, although the terms of the claims may differ. The second patent, although containing the broader claim, more generic in its character than the specific claims contained in the prior patent, is also void. But where the second patent covers matter described in the prior patent essentially distinct and separable from the invention covered thereby and claims made thereunder, its validity may be sustained."

The court further says in that case:

"It must distinctly appear that the invention covered by the later patent was a separate invention, distinctly different and independent, not covered by the first patent."

Now, claims 3 and 4 of the patent in suit may well be held to be a separate invention, distinctly different from and independent of the claims of the earlier patent, No. 359,551. The claims of the earlier patent are for combinations, and the leading novelty in those combinations is the double grooved pulley. All the combinations of that patent are different from the combinations of claims 3 and 4 of the patent in suit; but if you give the first two claims the broad construction contended for by the complainant, then the invention in No. 359,551 is covered by those two claims of the patent in suit.

With this more limited construction of claims 1 and 2 of the Bassett patent, giving the complainant the benefit of all that is new in its combinations, and not giving him the benefit of his grouping of old elements with old combinations, we are able to escape the charge of double patenting with reference to patent No. 359,551, and to give full effect to claims 3 and 4 in his patent. With this construction of the patent in suit, we do not think the defendant's apparatus is an infringement of the Bassett patent in suit. The drawings of defendant's machine show a different combination from those of the Bassett patent in suit. Bassett had three forms of hand controller: First, that of patent No. 359,551; second, that of Figs. 3, 4, and 5 of the patent in suit; third, Figs. 1 and 2 of the patent in suit. It does not appear that the defendant's controllers appropriate any one of these three forms, but are patentably different from them. If we should give to Bassett's two claims in suit the broad construction, "for any device combined with the standing cable whereby one is positively paid out and the other is taken up," then the defendant's device would be covered by the Bassett claims, and would be an infringement; but we do not think that this broad construction should be given to those two claims of the Bassett patent. The pulleys in the Bassett patent in suit swing through an arc, are operated in an entirely different way, and consist of a different combination from the combination used by the defendant. If we should hold the defendant's machine to infringe the complainant's two claims in suit, we should be suppressing a substantially different combination of elements.

The court must hold that claims 1 and 2 of the patent in suit do not admit of the interpretation contended for by complainant. Bassett's invention must, therefore, be restricted substantially to claims 3 and 4, which claims the defendant has not infringed.

The defendant makes the further defense that the patent in suit, if valid, expired September 26, 1902, with the British patent No. 13,890, and that no injunction can issue, even if the patent in suit has been infringed. In view of the above conclusions, it is not necessary to decide with reference to the British patent and to the contentions touching same.

The decree must be that the bill be dismissed, with costs.

Let the defendant file a draft decree on or before January 24th, dismissing bill, with costs; and the complainant may file corrections thereof on or before February 10th.

LUDINGTON NOVELTY CO. v. LEONARD et al.

SAME v. FISCHER et al.

(Circuit Court, S. D. New York. November 29, 1902.)

1. **PATENTS—CONSTRUCTION OF CLAIMS—AMENDMENTS IN PATENT OFFICE.**
An element or feature added to a claim of a patent by amendment to meet objections of the patent office in order to obtain a patent must be held essential in a suit for infringement.
2. **SAME—INFRINGEMENT—GAME-BOARDS.**
The Haskell patent No. 602,179, for a game-board, claims 1, 3 and 6 construed, and *held* not infringed.
3. **SAME.**
The Fuller patent No. 666,742, for a game-board, claims 1 and 2 construed, and *held* not infringed.
4. **TRADE-MARKS—DESCRIPTIVE WORD—"CARROMS."**
The word "Carroms" as applied to a game to be played with disks, where the object is not to strike two disks together, but to drive a single one into a pocket, or to the boards on which such game is played, is not so descriptive but that it may be appropriated as a trade-mark. The Haskell registered trade-mark No. 29,775, for the word "Carroms" as applied to game-boards, *held* valid and infringed.

In Equity. Suits for infringement of letters patent No. 602,179, for a game-board, issued to Henry L. Haskell April 12, 1898, and No. 666,742, also for a game-board, granted to F. A., C. D., and F. D. Fuller January 29, 1901, and for infringement of the registered trade-mark "Carroms" (No. 29,775), as applicable to game-boards, and to restrain unfair competition. On final hearing.

Fred. L. Chappell, for complainant.
Taggart, Denison & Wilson, for defendants.

TOWNSEND, Circuit Judge. The claims which it is contended are infringed are as follows:

Of No. 602,179:

"1. The combination of a game-board having a face, a rim projecting above the face, a cushion on the rim, a base-line on each side of the board extending across the board from the innermost portion of a pocket-opening to the corresponding portion of the opposite pocket-opening, and yielding pockets outside the base-line, with sets of disks adapted to be grouped about the center of the face, and disk adapted to be snapped from a base-line to impel the other disks into the pockets either directly or by the deflecting action of the cushion, substantially as described."

"3. In a game-board the combination of a face, a series of pockets, a rim forming the outer boundary of each pocket, and having a central recess for each pocket extending above and below the plane of the face of the board, and adapted to receive the impact of the playing-disk and deflect the same into the bottom of the pocket, substantially as described."

"6. In a game-board the combination of a face, a rim, openings in the face for pockets, a groove in the rim for each pocket below the face, a wire secured by each groove and encircling the openings, and pockets held about the openings by the wires, substantially as described."

¶ 2. Arbitrary, descriptive or fictitious character of trade-marks and trade-names, see note to Searle & Hereth Co. v. Warner, 50 C. C. A. 323.

Of No. 666,742:

"1. In a game-board, the combination of a plane board; a rim around the same; a space cut in a corner of the board and a groove T, formed in the edge of the board and rim; a hoop E, to rest within the said groove; and a netted pocket through the edges of which the hoop extends, as specified.

"2. In a game-board, the combination of a plane board; a rim around the same; a space cut in a corner of the board; and a groove T, formed in the edge of the board and rim opposite thereto at the corners; a hoop E, to rest within said groove; and a pocket through the edges of which the hoop extends, as specified."

Haskell, the patentee of patent No. 602,179, made a game-board in which flat disks were placed in the center of the board, and the players endeavored, by snapping with their fingers a flat disk against them, to drive the disks into pockets at the corners of the board. He applied for a patent, which was refused.

Plaintiff's brief describes his construction at that time as follows:

"A structure having a comparatively heavy panel with a rim around it; boxes in each corner supported by heavy diagonal blocks. There was no cushion on the rim, no recesses in the rim, and the structure was awkward, heavy, and cumbersome, and not a satisfactory board, owing to the fact that the disks when attempted to be utilized in this way would not be effectively retained or would not be readily lodged in the pockets when propelled with force."

By "panel" is to be understood the board upon which the disks are placed, in distinction from the rim.

Complainant's brief describes Haskell's work, subsequent to the denial of the application for a patent, as follows:

"Haskell continued the work and improved this board. He made a very light panel, put a heavy rim around it, which served as a strong support; placed cushions of felt on the rim, which deadened the noise and increased the resiliency, and, owing to the fact that a heavy rim was around the board, was able to shape into the same depressions for properly deflecting the pieces into the pockets. The pockets he found could be supported by a loop of wire, he having found it unnecessary to put heavy braces across the corners, as he had done in the earlier structure."

The claims of the second application were repeatedly rejected, and finally allowed after amendments of specification and claims. After the first rejection, a claim was filed containing as an element "the base line adjacent to the rim," and this claim was finally allowed, after amending, on the suggestion of the patent office, said element to "a base line on each side of the board, extending across the board from the innermost portion of the pocket opening to the corresponding portion of the opposite pocket opening." Complainant contends that the precise position of this base line is not essential. Inasmuch as the words absolutely fixing its location were inserted in order to obtain a patent after the rejection of the former claim, it must be held to be essential, and, as defendants' board does not contain this base line in this position, the first claim is not infringed.

The third claim was given its present form after repeated rejections, upon citations of different patents claimed to anticipate the recesses there mentioned; and after Haskell had been forced to describe in his specifications certain compound curves, making this recess somewhat different from the others cited. It must, therefore,

be limited to the construction described in the specifications and claim. In this claim, the central recess for each pocket extends above and below the plane of the face of the board, and in these claims "face" manifestly means the panel or board upon which the disks are moved. Defendants change the position of their cushion at the pockets, carrying it higher at that point; and complainant insists that this provides a rim which deflects the disks into the pockets, thereby performing the same service as Haskell's recess, and constituting its equivalent. But Haskell, to obtain his patent, and avoid the anticipations in the patent office, was compelled to rely on that part of his recess which extends below, as well as that above, the plane of the face of the board, and which forms a part of the compound curves relied on by him in obtaining his patent, and cannot now successfully maintain that this feature is not essential. Defendants' groove does not extend a sufficient distance below the panel to constitute infringement.

It is very difficult to find patentable invention, or, indeed, very great mechanical skill, in the mode of attaching the pockets described in the sixth claim of the Haskell patent. In this claim, a wire supporting the pockets encircles the opening for the pocket, being fitted into a groove in the rim lower than the face or panel, and, for the remainder of the distance, being attached to the under side of the face or panel. Defendants' wire, in the construction used when this suit was brought, does not encircle the opening, and only extends part way around. As far as the rim extends, the pockets are held by the wires, and, for the remainder of the distance, are attached to the board by staples. Even if the claim involved patentable invention, upon the narrow construction which must be given to this patent, defendants should be held not to infringe.

The Fuller patent was also allowed after repeated rejections and amendments. The improvements claimed for this patent are described by complainant as follows:

"The object was to have a more substantial fastening for the pocket than had been secured by Haskell or by Williams or any one else. To accomplish this, the Fullers cut a groove in the edge of the panel opposite the groove in the rim, so that the wire loop could be easily snapped into the same, and by its tension force the loops of the netted pocket into these recesses and retain them securely."

This is a very simple and convenient way of inserting a flexible pocket which may be turned in either direction. The board of examiners have found that it involved patentable invention. Even if it does, it must be found that, since the issuing of the patent, defendants have not made or intentionally sold or used an infringing device. In view of the Archerina construction and the Hall and Bock patents, and the action in the patent office on appeal, a complete hoop must be held to be an essential part of the invention; and this defendants do not use.

The claimed trade-mark is as follows:

"My trade-mark consists of the arbitrarily selected word 'Carroms.' * * * It is immaterial in what form or type the letters of the word appear, and it is observed that the word 'Carroms' has an equivalent in its variant 'Caroms,' or in any such fanciful spelling of the word as 'Karroms' or 'Karoms,' inas-

much as these words have the same root, and, when used in speaking, have the same sound. The word may also be accompanied by explanatory words, as, for example, in the phrase, 'Carroms Game,' or 'Carrom Game.' The essential feature is, however, as I have indicated, the word 'Carroms.'

"This trade-mark I have used continuously in my business since the first day of December, 1892.

"The class of merchandise to which this trade-mark is appropriated is games and toys, and the particular description of goods on which it is used by me is game-boards."

Defendants claim that the word "Carrom" is descriptive, and therefore cannot be a proper subject for a trade-mark. Complainant relies upon the decision of the circuit court of appeals for the Seventh circuit in *Williams v. Mitchell*, 45 C. C. A. 265, 106 Fed. 168. In that opinion it is held that the word "Carrom" is a descriptive word in billiards, but is not properly a descriptive word in a game to be played with disks, where the object is not to strike two separate disks or balls, but to drive a disk into a pocket. Defendants have introduced a considerable amount of evidence as to the use of the word "Carrom" which was not before the court in the case referred to, and this has required a reconsideration of the matter. Defendants insist that the evidence in this case differs so widely from that in the *Williams v. Mitchell* Case, *supra*, that no attention should be paid to that decision. The principal differences thus claimed are: Admissions of Mr. Haskell, who originally registered the trade-mark "Carroms," and of Mr. Bostwick, complainant's expert, on cross-examination, that the word "Carrom" is used in a popular sense to describe one object's hitting and glancing away from another; the use of the word "Carromette" as a name of a game by the Mitchell-Bradley Company in 1872, an argument made by complainant's solicitor when he was defending a former suit by the same complainant as to such use; the use of the words "The Game of Carrom" by the Mitchell-Bradley Company in 1882; the use of the words "Disco, The Great Carrom Game," by Mr. Horsman in 1892; the use of the word "Carrom" as descriptive of certain games of billiards; certain games played with either disks or rings wherein carroms in the strict sense were made,—carroms in the strict sense being the case where one ball strikes another, and then, glancing, strikes a third. It sufficiently appears that the use of the word "Carrom" was never brought into general use by Mitchell-Bradley Company or Horsman, and that it was abandoned by them before it was adopted by Haskell, and neither of them are objecting to complainant's appropriation of it. The use of the word by the Mitchell-Bradley Company closely approximated its use in the strict sense in billiards. It was used by Horsman as descriptive, and not as the name of a game. The popular sense, admitted by Haskell and Bostwick, appears to have been considered in the *Williams v. Mitchell* Case, where the court says, "for, while a carrom is possible, it is no part of the game, which consists in pocketing the disks, rings or balls." So, in the games in question, where the object is to pocket the disks or to place them in some particular position, and this is accomplished by striking other disks against them, "Carroms," in the popular sense cited, may be used by causing a disk to strike against and glance away from the

rim before striking the disk intended to be pocketed, but this is not sufficient to make the word "Carrom" descriptive of the game, or to prevent the application of the reasoning adopted in *Williams v. Mitchell*, supra. Upon consideration of the whole evidence, it seems reasonably clear that this word is not so descriptive of complainant's game-board that it could not fairly be adopted as a trade-mark. If the complainant or its assignors had not brought the word into general use as applicable to the style of game-board and games in question here, it is not probable that it would have been generally so used or understood, or that defendants would have made use of it in the way they have. On the whole, it seems reasonably certain that defendants are endeavoring to profit by the reputation gained by the complainant for the class of game-boards and games in question, and, while they may do so by any legitimate means, they should be kept strictly within their legal rights.

A decree may be entered for an injunction in regard to the use of the word "Carrom" or "Carroms" as applied to game-boards, also to games other than those in which the principal object is to score by making points in the manner in which they are made by carroms in billiards, as distinguished from the manner in which they are made in pool.

GOSS PRINTING-PRESS CO. V. SCOTT.

(Circuit Court, D. New Jersey. December 17, 1902.)

1. REFERENCE—ACCOUNTING IN PATENT SUIT—PRODUCTION OF CORRESPONDENCE.
On an accounting before a master for profits and damages for infringement of a patent, where defendant has produced the contracts of sale of the infringing machines, he may properly be required, under the provisions of equity rule 77, to also produce the correspondence leading up to such contracts, as being applicable to the subject-matter of the reference.

In Equity.

Charles E. Pickard, for the motion.

Benjamin F. Lee and James G. K. Lee, opposed.

KIRKPATRICK, District Judge. This is an application for an order that the defendant produce before the master for an accounting for profits and damages for infringement of letters patent certain correspondence leading up to the sale of certain machines containing infringing devices and designated in this proceeding. I am of the opinion that under the provision of equity rule 77 the complainant is entitled to the production of this correspondence as being applicable to the subject-matter of the reference.

An order may be entered accordingly.

¶ 1. Accounting by infringer for profits, see note to *Brickill v. Mayor*, etc., 50 C. C. A. 8.

CHESAPEAKE & O. COAL AGENCY CO. v. FIRE CREEK COAL &
COKE CO. et al.

(Circuit Court, S. D. West Virginia. December 12, 1902.)

1. JURISDICTION OF FEDERAL COURTS—DISTRICT OF SUIT.

A circuit court of the United States is without jurisdiction of a suit as against defendants who are nonresidents of the district, where the complainant is also a nonresident, and the only ground of jurisdiction is diversity of citizenship, unless such defendants directly waive their privilege by submitting themselves to the jurisdiction of the court; and the filing of a demurrer to the bill, although on other grounds, is not such a waiver.

2. INJUNCTION—RIGHT TO RELIEF—UNLAWFUL INTERFERENCE WITH PERFORMANCE OF CONTRACT.

The bill of plaintiff corporation alleged that it was engaged in the business of selling coal and coke; that it had contracts with defendant coal companies by which it was to take all their product at the mines, to furnish transportation, and sell the same at prices fixed by the companies, receiving a stipulated sum per ton for its services; that by the terms of such contracts defendants were not liable for damages for failing to furnish coal to plaintiff, where such failure was caused by strikes; that in reliance on such contracts plaintiff had made contracts for the sale of large quantities of coal and coke, and had provided vessels for its transportation from the seaboard; that the defendant companies were willing to furnish such coal and coke, but were prevented from doing so by the wrongful and illegal acts of individual defendants, who were conducting a strike among the miners, and who by intimidation and threats prevented others from working in the mines. *Held*, that the bill showed such contract rights in plaintiff as entitled it to maintain the suit in its own right for their protection, independently of the defendant companies, and that it stated a cause of action for an injunction against the individual defendants to prevent their further unlawful interference with the performance of the contracts by the coal companies; it being further shown that plaintiff was without adequate remedy at law.

3. SAME—PARTIES.

To such suit the coal companies were proper parties defendant; but the fact that they might not be averse to the granting of the relief prayed for would not authorize the court to align them on the side of the plaintiff in the suit, where that would defeat the court's jurisdiction, since plaintiff did not sue in their right, but in its own.

In Equity. On demurrers to bill.

J. W. St. Clair, C. W. Dillon, and W. E. Chilton, for plaintiff.
Chas. E. Hogg and S. C. Burdett, for defendants.

KELLER, District Judge. This case comes up on demurrer to the bill herein. The defendants jointly and severally, and defendant G. W. Purcell separately, have interposed their demurrers to the bill filed herein, setting up the following as grounds for the demurrers:

"First. That the said plaintiff has not, in and by the said bill, made or stated any such case as doth or ought to entitle it to any such discovery or relief as is thereby sought and prayed, from, for, and against these defendants or any of them.

"Second. Because, as appears from the said bill, the said plaintiff hath no such interest in the subject-matter of complaint alleged against the above-

¶ 1. Waiver of right as to district in which suit may be brought, see note to *Bank v. Houchens*, 52 C. C. A. 192.

named defendants as entitles the said plaintiff to any relief sought against them or any of them.

"Third. It appears from the allegations of said bill that the United States circuit court hath no jurisdiction of this cause, inasmuch as it appears that the Fire Creek Coal & Coke Company, Alaska Coal & Coke Company, Beechwood Coal & Coke Company, and all the other coal companies mentioned in said bill, and proceeded against as defendants therein, have interests in the subject-matter of said bill which will properly align them on the side of the plaintiff therein instead of with the defendants named in said bill, and the said coal companies must be aligned on the side of their real and true interests in determining the question of jurisdiction; and it appearing from said bill that said coal companies should be arranged on the side of the plaintiff in this case, and that each and all of them mentioned as defendants to the said bill are corporations created and organized under the laws of the state of West Virginia, and as such are citizens of the state of West Virginia, and that nearly all of the other defendants to the said bill are residents and citizens of the state of West Virginia, there is no such diverse citizenship shown in this case as to give jurisdiction to the said court, either for the purpose of maintaining the said bill or issuing an injunction thereon.

"Fourth. Because the court is further without jurisdiction, and especially for the issuance of an injunction herein, because, as appears from the allegations of said bill and the present arrangement of the parties therein, the plaintiff is a citizen of the state of New Jersey, and the Fire Creek Coal & Coke Company, and all of the other coal companies mentioned as defendants in said bill, are corporations created and organized under the laws of the state of West Virginia; and the defendant the Chesapeake and Ohio Railway Company is a corporation created under and by virtue of the laws of the states of Virginia and West Virginia, and is therefore a citizen of each of said states; that the defendant W. P. Rend is a citizen and resident of the state of Illinois; that the defendants G. W. Purcell and W. B. Wilson are citizens and residents of the state of Indiana; and that the defendant John Mitchell is a citizen and resident of the state of Pennsylvania; and all of the other natural persons designated as defendants on the face of said bill are citizens and residents of the state of West Virginia; that by the amendment made to the plaintiff's bill on the 13th day of August, 1902, by an order entered in Chancery Order Book No. 1, page 172, the following named persons were added as defendants to said bill by way of an amendment thereto: Joe Prenosel, T. B. Delong, Sam Washington, J. W. Ewing, James McIver, R. L. Bess, James Sizemore, Ed. Scott, H. F. Hawks, C. Totten, Joe Smith, Robert Mason, Burt Campbell, Vint Miller, Hillie Hutchinson, John Uposky, George Holcomb, Henry Mosby, Mat Ratliff, James Hager, M. M. Mason, C. F. Stewart, Mike Fleming, Bob Richards, Dave Davis, Jack Davis, Thos. Campbell, Thos. Hughes, Will Robinson, Arthur Towmaw, W. R. Smith, W. H. Thompson, Charles Kauff, John Wyman, Henry Wessell, Bob Morrison, J. F. Kirk, Duncan Kennedy, and W. H. Martin; and that it does not appear from the bill, filings, and papers in the cause of what state the said last-named defendants, added to said bill by way of amendment to said bill as aforesaid, are citizens, whether of the state of New Jersey or some other state; that on the 2d day of September, 1902, the said bill was further amended by an order entered of record in Chancery Order Book No. 1, page 174, making the following named persons defendants to said bill: The St. Clair Company, a corporation, L. H. Suddith, L. M. Hepenstall, George W. Riser, Eli Elswick, John Ervin, Windy Hannah, James Massey, John Phillips, Andy Forbs, Ed Caldwell, and Laurel Coal & Coke Company; that it does not appear from the said bill, filings, and other papers in said cause of what state the said last-named persons are citizens; and that on August 2, 1902, the said bill was further amended by order entered in said cause on said 2d day of August, 1902, in Chancery Order Book No. 1, page 169, by making the following named persons also defendants to said bill: The Stevens Coal Company, George Bryant, Morris McGrath, W. L. Williams, Sr., and C. E. Williams; that it does not appear from the said bill, filings, and orders in said cause of what state or states the said last-named persons are citizens.

"Fifth. Because it clearly appears upon the face of the said bill that the

said plaintiff is in fact not the real party in interest, but that the said Fire Creek Coal and Coke Company, and all the other coal companies, corporations, mentioned and proceeded against as defendants in the said bill conjointly with these demurrants, are the real and substantial parties in interest with reference to the matters and things alleged in said bill of complaint, and on whose behalf this suit was in fact instituted by an agent of the said coal and coke companies, each of said coal companies seeking to avoid a separate and distinct suit, if any it hath, on its own behalf and under its own name.

"Sixth. Because there is a misjoinder of parties defendant in said bill of complaint, in that the said Fire Creek Coal and Coke Company, and each of the other coal companies mentioned and proceeded against as defendants in said bill, are improperly joined with the above-named defendants to said bill.

"Seventh. Because the allegations of the said bill upon which the said plaintiff predicates its ground of relief are too uncertain, vague, and indefinite to authorize a court of equity to grant any relief thereon.

"Eighth. Because, disregarding and eliminating the insufficient allegations of said bill by reason of their vagueness, uncertainty, and indefiniteness, there is no such showing on the face of said bill as authorizes the exercise of the jurisdiction of a court of equity and the issuance or maintenance of an injunction in this case."

There is one matter not mentioned in the argument by counsel, and not incorporated in either of the written demurrers filed to this bill, which, nevertheless, appears upon the face of the bill, and must therefore be considered by the court in passing upon these demurrers.

The plaintiff corporation is alleged to be a citizen and resident of the state of New Jersey. The following demurring defendants are alleged in the bill to be citizens and residents of states other than West Virginia, as follows: G. W. Purcell, of the state of Indiana; W. B. Wilson, of the state of Indiana; and John Mitchell, of the state of Pennsylvania.

The jurisdictional act of 1887 [U. S. Comp. St. 1901, p. 508] provides, among other things, that in a suit in a United States court, where the only ground of jurisdiction is that the suit is between citizens of different states, suit shall be brought in the district of the residence of either the plaintiff or the defendant. A long line of decisions, including numerous decisions of the supreme court of the United States, hold that this requirement is jurisdictional, and that jurisdiction can only be acquired by some direct waiver by defendant in submitting himself to the jurisdiction of the court. See *Bank v. Slocomb*, 14 Pet. 60, 10 L. Ed. 354; *Thayer v. Wales*, 5 Fish. Pat. Cas. 448, Fed. Cas. No. 13,872; *Noonan v. Railroad Co.* (C. C.) 68 Fed. 1.

Here the defendants, through their counsel, have demurred to the bill, and, following the decisions above referred to, the separate demurrer of G. W. Purcell must be sustained, and the demurrer must also be sustained as to defendants John Mitchell and W. B. Wilson.

In the argument the first, second, and fifth grounds of demurrer were considered together, as were also the seventh and eighth points, and in this opinion they may, I think, be grouped as they were in the argument.

The first, second, and fifth grounds substantially allege that plaintiff shows no equity in its bill; that it is not the substantial party in interest, but that the coal company defendants are the real parties

in interest; and that this suit is brought by their agent, on their behalf, to avoid the bringing of separate suits by these coal company defendants. If this is true, and appears upon the face of the bill, the bill should be dismissed on demurrer. But I cannot see that this does appear on the face of the bill. It may be true, perhaps is, that the various coal company defendants are not averse to the action sought to be taken by the plaintiff; but if the plaintiff company has such an interest in the subject-matter in controversy that it will support an action, independently of any interest of the coal companies, and is by this proceeding seeking relief in equity which cannot be adequately afforded at law, either from the insolvency of defendants, their multitude, or for any other of the grounds that authorize a resort to a court of equity, then the mere fact that the defendant companies are not averse to the sustaining of such rights on the part of the plaintiff cannot make them the real parties in interest in this proceeding, or take away the right of plaintiff to pursue its only effective remedy.

I fully realize the importance of proceeding in this case in accordance with correct principles, and, in order that we may have the controversy presented by the bill clearly before us, let us see very briefly what are its substantial averments of importance. After making the ordinary jurisdictional averments, it proceeds to state that plaintiff (and its predecessor) has built up a coal-selling business amounting in value to \$50,000 a year; that the plaintiff is and has been practically the exclusive selling agent in eastern and foreign markets for the sale of the coal for all of the defendant companies, and has contracts with all of them for the sale of such coal at a price fixed by the producing companies, plaintiff to receive 10 cents per ton out of such selling price; that it has sold more than 2,000,000 tons of coal and several hundred thousand tons of coke for delivery during the current year; that complainant takes charge of the coal at the mines, and must provide for the water transportation of such coal as is sold for delivery at ports beyond Newport News, and has under contract a number of vessels to receive the product of the mines; that since June 7, 1902, a strike has existed at the mines of the companies, the individual defendants being strikers and members of the organization conducting and controlling the strike; that since said date plaintiff has received but little coal and no coke from the defendant companies; that the companies are willing to ship coal to it, and there are a large number of persons who are willing to work for said companies, but who have been and are intimidated from doing so by the acts and conduct of the individual defendants; that said defendants have openly said that men who will work during the strike will be black-listed, and will be unable to get work anywhere in the United States, etc., and have thus prevented them from continuing to work; that the contracts with the coal companies contain a clause exonerating them from damage for failing to furnish coal upon their contracts where such failure is caused by a strike of the employés, etc. The bill, upon its face, in my judgment, shows that the defendant companies are being prevented, wholly or partially, from fulfilling their contracts with plaintiff, by acts and

conduct upon the part of the individual defendants and their aiders and abettors, which is unlawful and wrong.

Does this present such a case as would support an action at law by plaintiff against the individual defendants for causing a failure on the part of the mining companies to deliver coal under their contracts? The defendants' liability for any tort is held to extend to all those who suffer injury therefrom as a natural result of the act. The case of *Griggs v. Fleckenstein*, 14 Minn. 81 (Gil. 62), 100 Am. Dec. 199, furnishes an example of the extent to which this principle is carried. In that case the defendant negligently left his horses on the street unsecured. They ran off. People in the street halloosed and raised their arms before them, and caused them to swerve from their course and to collide with another team, properly tied. This second team ran off and injured the plaintiff's horse. The defendant was held liable. The immediate cause of the injury was the collision of the second team with plaintiff's horse, but the earlier wrongful act of the defendant in leaving his team negligently unguarded is regarded as the primary and efficient cause, acting through these subsequent events.

Nor is this principle of this line of cases new. The leading case is the familiar "squib" case of *Scott v. Shepherd*, 2 W. Bl. 892, also reported in 1 Sm. Lead, Cas., page 737 of the American Edition, where it was held that trespass and assault would lie for originally throwing a squib, which, after having been thrown about in self-defense by two other persons in a market house, at last was thrown against the plaintiff and put out his eye. Nares, J., said: "That the natural and probable consequence of the act done was injury to somebody, and therefore the act was illegal at common law."

Upon principle can it make any difference as to my right of action if a man, by an illegal act, injures me or injures my property? Have I not rights as against him in either case? And is a case not too remote to give me a right of action as to my person too remote to protect me as to my property? The Minnesota case would seem to indicate that it is not, and there is a much older case still more in point. In the case of *Tarleton v. McGawley, Peake, N. P. (Ed. 1795) p. 270*, the action was special on the case. The declaration averred that plaintiffs owned a certain ship named the *Tarleton*, which at the time of committing the grievance was lying at Calabar, on the coast of Africa, having been fitted out and sent thither for slaves and other goods; that the plaintiffs had also sent a smaller vessel, called the *Bannister*, similarly loaded for trading with the natives, to another part of the coast, called Cameroon, for the purpose of trading with the natives there; that while the *Bannister* was lying off Cameroon a canoe, with some natives on board, came to the vessel for the purpose of establishing a trade, and went back to the shore, and that the defendant, knowing this, but contriving and maliciously intending to hinder and deter the natives from trading with the master of the *Bannister* for the benefit of the plaintiffs, with force and arms fired from a certain ship called the *Othello* a certain cannon at the canoe, killing one of the natives, whereby the natives of the coast were deterred and hindered from trading with

the Bannister, and the plaintiffs lost their trade. The court held the declaration to state a cause of action, and Lord Kenyon said:

"The injury complained of is that by the improper conduct of the defendant the natives were prevented from trading with the plaintiffs. The whole of the case is stated on the record, and if the parties desire it the opinion of the court may hereafter be taken whether it will support an action. I am of opinion it will."

These cases, particularly the last one, seem very much in point. In that case no contract rights existed on the part of the owners of the Bannister. There is no allegation that they had any trade agreements with the natives or their chiefs, but yet it was held that the unlawful act of the owners or crew of the *Othello*, inasmuch as it prevented the natives from trading with plaintiffs, was a good foundation for a special action for damages.

Can it be doubted that, if there had been a threatened repetition of the unlawful interference, and the defendants were alleged to be insolvent, equity could have intervened by way of injunction to prevent further injury?

It is urged in argument that the plaintiff here is but the agent of the defendant coal companies, and the connection between it and them is too slight to support a suit brought by it. In the first place, the so-called agency, as shown by the bill, is, if an agency at all, coupled with an interest in the subject of the contract; that is, the coal of defendant companies. The plaintiff avers that it has made contracts for the sale of upwards of 2,000,000 tons of such coal for delivery during the current year, and, inasmuch as it is personally responsible to the coal companies for the net price of the coal as soon as delivered to it in the cars, it has practically bought this coal for delivery upon its sale contracts. Its business, which it has built up in the course of years, is its property. It has contractual trade relations with these defendant companies, and I can see no reason why it would not have a right of action against any one who by a wrongful act should render these companies incapable of carrying out their contracts with it.

In Story, Ag. § 394, it is said:

"Where the agent has made a contract, in the subject-matter of which he has a special interest or property, whether he professed at the time to be acting for himself or not, the agent acquired personal rights, and may maintain an action upon the contract, in his own name, without any distinction, whether his principal is or is not entitled also to similar rights and remedies on the same contract."

If, then, the agent has obtained a special interest or property in the subject of the contract, has he not a right of action against a third party, whose wrongful act prevents the delivery by his principal of the subject of the contract? And if he has, and such remedy is ineffective, for any of the reasons warranting the interposition of equity in ordinary cases, may not he appeal to a court of equity for protection of this interest? Suppose the individual defendants had wantonly and maliciously induced the defendant companies to violate their contract with the plaintiff; would it not have a right of action against them? Undoubtedly. See *West Virginia Transp. Co. v. Standard Oil Co. (W. Va.)* 40 S. E. 591, 56 L. R. A. 804. And

if such right of action was ineffective, for any of the reasons authorizing a resort to equity, might it not ask an injunction to prevent the continuance of such interference? I think so. See *Railway Co. v. McConnell* (C. C.) 82 Fed. 65, a case in which a bill was filed by the railway company to restrain the defendants from carrying on the business of dealing in Tennessee Centennial Exposition special round-trip railway tickets, issued at reduced rates. The tickets were receivable for return transportation over different roads from those issuing them, and were not transferable. The defendants were ticket brokers or scalpers, engaged at Nashville in buying such tickets from holders, and reselling the return portions to others for use in violation of the contract. It was held: (1) That the railroad companies were entitled to injunctions. (2) That in a suit for an injunction the amount in dispute, for jurisdictional purposes, is not determined by the amount which the complainant might recover from defendant in an action at law for the acts complained of, but by the value of the right to be protected or the extent of the injury to be prevented by the injunction. (3) That in the use of the writ of injunction courts exercise discretion, and it is not a fatal objection that the use of the writ for a particular purpose for which it is sought is novel. (4) The right to carry on a lawful business without obstruction is a proper right, which should be protected by injunction when the ordinary remedies are inadequate. (5) The suit was not upon the contracts embodied in the tickets, but the subject-matter was the illegal use made of the tickets by defendants, not parties to the contract, to the injury of complainant, and therefore any remedy provided by the contract itself for its violation was not a bar to the relief sought. (6) One who wrongfully interferes in a contract between others, and induces one of the parties to break it, is liable to the party injured, and his continued interference may be ground for an injunction where the injury resulting will be irreparable. (7) It is not an objection to the jurisdiction of a court of equity to grant injunctions to protect property rights that the act sought to be enjoined may also be a violation of the criminal law. Attention is invited to the well-considered opinion of Judge Clark in this case.

It having been, as I think, conclusively shown that injunction would lie, in a proper case, if defendants had unlawfully induced the defendant companies to violate their contract with plaintiff, it only remains, under this branch of the case, to consider whether there is any difference between such a case and a case where the unlawful acts charged against defendants render it impossible of performance. I see no difference whatever in principle. It makes no difference whether a man is wrongfully and maliciously induced to cease business relations with me or whether he is maliciously and wrongfully prevented from doing so. The effect is the same. The means in either case are wrongful, and in either case the wrongdoer is liable, in so far as the injury is the natural and probable result of the wrongful acts.

While I appreciate the importance of the principle here to be decided, and would be glad to have a decision by a higher and more able court, I must act in the first instance, and I feel constrained to overrule the first, second, and fifth points of the demurrers.

The third point of the demurrers is likewise overruled upon the ground that the bill shows that the plaintiff has an independent interest in the subject-matter of the suit, which would be enforceable against the defendant companies themselves, and the mere fact that the defendant companies may not be averse to the success of plaintiff's suit cannot render their interests at all identical with plaintiff's interests. In fact, plaintiff seeks relief by injunction against defendant companies. (See prayer of the bill.)

I cannot well see how this bill could have been framed without making these coal companies at least formal parties defendant. A contract is alleged to exist with each of them giving plaintiff a right to the coal produced by each. They or any of them might deny the existence of such contract, or that its terms were as set out. But suppose they admit the contract, and simply content themselves with saying: "It is true that the contract exists as is stated in the bill, and that we (the coal companies) are relieved against any failure to furnish coal when such failure is caused by strike. A strike exists, but we could ship coal if it were not for the illegal acts complained of in the bill. This is all true, but we own this property, and this plaintiff has no right to manage it in any way. We prefer to be left to take care of our own interests in our own way." Suppose such an answer were made, would it not demonstrate that the plaintiff here has rights and interests which demand and are entitled to protection?

To my mind the defendant coal companies here are proper, and I believe necessary, parties, but I do not think they are, or could be made, parties plaintiff. This bill is framed to assert and protect its interest. That interest, while growing out of contracts made with the various coal company defendants, is yet separate and distinct from the property and interest of each and every of said defendant companies, and the pendency of this suit could not preclude the bringing of a separate suit for the same purpose by each of these coal company defendants for the purpose of protecting its own property from the illegal acts alleged in this bill against the individual defendants herein. Such suits, if brought, would not be for the protection of the rights and interests sought to be protected by this suit, nor would it be essential to make the plaintiff a party to any one of such suits. It seems to me that this statement is sufficient to show there is nothing in the third point of the demurrer.

Attention is invited to the discussion of the general doctrine of "parties" contained in the opinion of the court in the case of *Shields v. Barrow*, 17 How. 130, 15 L. Ed. 158. See, also, *Horn v. Lockhart*, 17 Wall. 570, 21 L. Ed. 657.

With regard to the fourth point of the demurrer, namely, that as to the parties made defendants by the respective orders of August 2, August 13, and September 2, 1902, it does not appear of what states they are citizens, respectively, I would say that, as at the time these orders were entered, no appearance had been entered by any of the defendants, it was no doubt contemplated that these new names should be inserted in the bill at the appropriate place, and I will permit the bill now to be amended by making any proper and necessary aver-

ments as to the citizenship of the defendants made parties by the orders of August 2, August 13, and September 2, 1902, and with leave to defendants to redemur when such averments are made.

The seventh and eighth points of the demurrer are overruled, as I think the allegations of the bill, while very general, are sufficient. The gist of the bill is the averment of a combination among the defendants to prevent the defendant companies from mining and shipping coal, and, in pursuance thereof, of illegal acts, threats, and demonstrations by defendants calculated to intimidate (and having such result) persons desirous of working for such defendant companies from doing so. I think this is made sufficiently clear in a general way in the bill, and, of course, it would not be proper to insert herein the particular facts which may be the basis of these charges, they being properly reserved for the proofs.

An order may go in accordance with this opinion.

In re DAVIS et al.

(District Court, W. D. Texas, Waco Division. January 26, 1903.)

No. 320.

1. BANKRUPTCY—JURISDICTION TO ORDER SURRENDER OF PROPERTY.

A court of bankruptcy has jurisdiction by a summary proceeding to require a third party having in his possession money or property claimed to belong to the bankrupt's estate to show cause why he should not pay over or surrender the same to the trustee, and to inquire into the nature of such party's possession. If he held it prior to the bankruptcy proceedings, under an adverse claim asserted in good faith, the court is without jurisdiction to adjudicate such claim on the merits without his consent; but, if no adverse claim was made at the time the petition in bankruptcy was filed, the title to the money or property passed to the trustee on his appointment, and the court has jurisdiction to require its surrender to him by a summary order, notwithstanding any adverse right subsequently asserted by the party in possession.

2. SAME—ADVERSE CLAIMANT—FUND HELD IN FIDUCIARY CAPACITY.

An insolvent partnership sold its stock of goods, and by its direction the purchaser deposited the price in a bank, taking a receipt therefor, showing that the money was to be prorated among the several creditors of the firm as their interests might appear. Subsequently, on petition of creditors, the partnership was adjudicated an involuntary bankrupt. After such adjudication the bank undertook to apply the money so deposited on certain notes of the firm held by it and another creditor, without the consent of the depositor or the bankrupts, and it refused the demand of the trustee therefor. *Held*, that the bank held the deposit in a fiduciary capacity, as a trust fund, which precluded it from asserting an adverse claim thereto after the bankruptcy as against the trustee.

3. SAME—ORDER REQUIRING FUND TO BE PAID TO TRUSTEE—INTEREST.

A summary order made by a court of bankruptcy requiring a third party to pay over to a trustee money of an estate in his possession should not include interest on the amount withheld.

In Bankruptcy. On review of order of referee.

The questions submitted for decision arise upon a petition for review filed by the First National Bank of Morgan, Tex., and W. H. Abernathy, challenging an order made by the referee in bankruptcy which required the bank to pay to the trustee in bankruptcy the sum of \$3,572.03, with legal interest.

The proceedings are of an involuntary nature, and during their progress a rule was entered by the referee, upon the application of the trustee, commanding the bank and Abernathy to show cause why the money should not be paid over to the trustee. The bank and Abernathy interposed a plea in which they protested against the jurisdiction of the court, mainly on the ground that the referee was without power to compel by summary process the payment of the money. A final hearing was had over the protest of the respondents, all parties being duly represented, and upon consideration the referee entered the order hereinafter set out, requiring the money to be paid. Exceptions were seasonably taken to the order, and the referee has certified the proceedings, as required by the rules, for the consideration of the court. For a more thorough understanding of the points involved, it is deemed proper to insert the following conclusions of fact found by the referee:

"First. That in the matter in controversy W. H. Abernathy was acting as agent for the First National Bank of Morgan, Texas, and that his acts were the acts of the First National Bank of Morgan.

"Second. That the \$3,572.03 arising from the sale of J. R. Davis & Co.'s stock of goods was deposited by Sam F. Drake, the purchaser of J. R. Davis & Co., on the 28th day of May, A. D. 1902, in the First National Bank of Morgan, Texas, to be prorated among the creditors of J. R. Davis & Co.

"Third. That on said 28th day of May, A. D. 1902, the First National Bank of Morgan had to the credit of J. R. Davis & Co. the additional sum of \$26.25, deposited by J. R. Davis & Co. on May 9, 1902.

"Fourth. That the involuntary petition in bankruptcy was filed herein against J. R. Davis & Co. on the 9th day of June, A. D. 1902, and that they were adjudged bankrupts on the 7th day of July, A. D. 1902, and that Edgar M. Mann qualified as trustee of said bankrupts' estate on the 1st day of August, A. D. 1902.

"Fifth. That the First National Bank of Morgan, Texas, did not make any claim to the deposit of money from the sale of stock of J. R. Davis & Co., made on the 28th day of May, A. D. 1902, at the time said deposit was made, nor at any time before the filing of the petition in bankruptcy, nor until the 9th day of July, A. D. 1902.

"Sixth. That J. R. Davis & Co. at the time of the filing of the petition in bankruptcy herein, and at the date of adjudication, owed the First National Bank of Morgan about \$2,486.75, evidenced by four notes, as follows: (1) Note for \$1,000, dated January 21, A. D. 1902, due September 15th, A. D. 1902, payable to the Bank of Morgan; (2) note for \$1,034, dated May 1, A. D. 1902, due 4 months after date, payable to the Bank of Morgan; (3) note for \$224, dated April 10, 1902, due 5 months after date, payable to Morgan Mill & Elevator Company; (4) note for \$228.75, dated May 10, 1902, due 5 months after date, payable to Morgan Mill & Elevator Company,—all of which had been transferred by the payees to the First National Bank of Morgan, Texas.

"Seventh. That J. R. Davis & Co. at the time of the filing of the petition in bankruptcy herein, and the date of adjudication, owed the Bank of Morgan the sum of \$3,017.10 and interest, evidenced by three notes, as follows: (1) Note for \$1,000, dated January 21, 1902, due October 10, 1902, payable to the Bank of Morgan; (2) note for \$1,000, dated January 21, 1902, due July 15, 1902, payable to the Bank of Morgan; (3) note for \$1,017.10, dated April 18, 1902, due on demand, payable to the Bank of Morgan.

"Eighth. That on July 9, 1902, the First National Bank of Morgan indorsed a credit of \$808.55 on note for \$1,000, dated January 21, 1902, due September 15, 1902, held by said bank, and a credit of \$750 on note for \$1,034, dated May 1, 1902, due 4 months after date, held by said bank; attempting thereby to appropriate those amounts of the deposit made on the 28th day of May, A. D. 1902, for the benefit of J. R. Davis & Co.'s creditors, to the payment of the debts due it.

"Ninth. That on July 9, A. D. 1902, the First National Bank of Morgan placed a credit of \$1,039.70 on note for \$1,017.10, dated April 18, 1902, payable on demand, held by the Bank of Morgan, and a credit of \$1,000 on note for \$1,000, dated January 21, 1902, due July 15, 1902, held by the Bank of Morgan; attempting thereby to appropriate the deposit made on the 28th day of

May, A. D. 1902, for the benefit of the creditors of J. R. Davis & Co., to the payment of a debt owed the Bank of Morgan by J. R. Davis & Co.

"Tenth. That the First National Bank of Morgan, Texas, had no interest in the two notes above held by the Bank of Morgan.

"Eleventh. That the First National Bank of Morgan, Texas, at the time of placing the credits on the notes above mentioned, did not notify either J. R. Davis & Co., Sam F. Drake, the trustee in bankruptcy, or any other creditor of J. R. Davis & Co., except the Bank of Morgan, that it intended to appropriate the deposit made on the 28th day of May, A. D. 1902, to the payment of the debt above set forth, and did not at any time before the 9th day of August, A. D. 1902, notify any of said parties that it had done so.

"Twelfth. That on August 1, A. D. 1902, Edgar M. Mann, the trustee in bankruptcy, made a demand on the First National Bank of Morgan, Texas, for the \$3,572.03 deposited on May 28, A. D. 1902, and that on August 5, A. D. 1902, the First National Bank of Morgan replied evasively to said demand, and that on August 9, A. D. 1902, Edgar M. Mann, trustee, made another demand upon said First National Bank of Morgan for the said money, and on said date the First National Bank of Morgan declined to pay over said money, claiming to have appropriated it to the payment of debts due the First National Bank of Morgan and the Bank of Morgan."

The conclusions of the referee are clearly supported by the evidence appearing of record, which further discloses the following facts: The First National Bank of Morgan was organized May 8, 1902. The Bank of Morgan was a partnership concern, composed of G. H., W. H., and Walter Abernathy. W. H. Abernathy was the cashier of the First National Bank of Morgan, and cashier and general manager of the Bank of Morgan. The Bank of Morgan ceased to do a banking business upon the organization of the First National Bank, and transferred its business to that bank, which assumed to pay the depositors of the Bank of Morgan out of assets transferred to it by the Bank of Morgan for that purpose. On May 8, 1902, the date of the organization of the First National Bank, J. R. Davis & Co., the bankrupts, owed the Bank of Morgan about \$5,500, evidenced by seven promissory notes, and at the same time the Bank of Morgan transferred to the First National Bank of Morgan four of these notes, aggregating, approximately, \$2,486.75. The bankrupts sold their stock of goods to Samuel F. Drake on or about May 21, 1902, and the bill of sale executed by them, among other things, expressly provided that the proceeds of the sale should be prorated among their several creditors. Drake, the purchaser, accompanied by Mr. Hardin, who acted in the matter as representative of J. R. Davis & Co., called at the First National Bank on May 28, 1902, and delivered the proceeds of the sale, to wit, \$3,572.03, to the cashier, W. H. Abernathy, who duly executed a receipt therefor in the following form: "Received of Sam'l F. Drake, for acct. of J. R. Davis & Co., the sum of thirty-five hundred and seventy-two ⁰⁸/₁₀₀ (\$3,572.03), to be prorated among the several creditors of J. R. Davis & Co. as their interests may appear."

The order passed by the referee, requiring the First National Bank of Morgan to pay over the money deposited with it by Drake and Hardin, is as follows:

"Having fully considered the application of Edgar M. Mann, trustee, for rule against W. H. Abernathy and the First National Bank of Morgan, Texas, requiring them to show cause why they should not turn over to the trustee \$3,572.03, together with the plea of W. H. Abernathy and the First National Bank of Morgan, Texas, to the jurisdiction of the court to entertain such motion and make such order asked for, and having fully heard and considered testimony taken upon said motion and plea, on the 13th day of November, A. D. 1902, it is ordered that the plea to the jurisdiction be, and is hereby, overruled. It appearing from the testimony that W. H. Abernathy has no money in his possession belonging to the estate of J. R. Davis & Co., it is ordered that the said motion, as against said W. H. Abernathy, as an individual, be, and is hereby, refused, and that all costs attending upon this motion against W. H. Abernathy be taxed against the trustee. It appearing from the testimony that on the 28th day of May, A. D. 1902, Sam F. Drake

deposited with the First National Bank of Morgan, through W. H. Abernathy, its cashier, the sum of \$3,572.03, to be prorated among the several creditors of J. R. Davis & Co. as their interests may appear; it further appearing to the court that this deposit was made to the said First National Bank of Morgan in trust for the creditors of J. R. Davis & Co., and that thereby the First National Bank of Morgan was constituted an agent or trustee for the creditors of J. R. Davis & Co.: It is therefore ordered that the application of the trustee herein be granted; and it is further ordered that the First National Bank of Morgan, Texas, be, and is hereby, required to pay over to Edgar M. Mann, trustee in this cause, within ten days from this date, the sum of \$3,572.03, with interest thereon from the 5th day of August, A. D. 1902, at the rate of six per cent. per annum. It is further ordered that the First National Bank of Morgan, Texas, be, and is hereby, ordered to pay all costs of this proceeding, except such costs as attached to motion against W. H. Abernathy.

M. C. H. Park,
"Referee in Bankruptcy."

Throughout the entire proceeding the respondents, claiming to hold the fund adversely to the trustee, objected to the jurisdiction of the court, and insisted that the court was powerless, without their consent, to make an order requiring them to pay over moneys so adversely held.

Claude V. Birkhead and Davis & Cocke, for trustee.
J. D. Williamson, for respondents.

MAXEY, District Judge. The only question necessary to be considered is whether this court, as a court of bankruptcy, has jurisdiction to compel, by summary process, and over the protest of the First National Bank of Morgan, the payment of the money, deposited with the bank by Drake and the bankrupts, to the trustee in bankruptcy. That jurisdiction exists generally to require, in a summary manner, the bankrupt or a third person to pay over money or to surrender other property in his possession belonging to the bankrupt's estate, to which no adverse title is asserted, seems to be well settled by recent adjudications; and the payment or surrender, in the one case or the other, may be required notwithstanding the person against whom the order is directed may not consent to the jurisdiction of the court. *Mueller v. Nugent*, 184 U. S. 1, 22 Sup. Ct. 269, 46 L. Ed. 405; *Trust Co. v. Comingor*, 184 U. S. 18, 22 Sup. Ct. 293, 46 L. Ed. 413; *In re Rosser*, 41 C. C. A. 497, 101 Fed. 562. See, also, *Bryan v. Bernheimer*, 181 U. S. 188, 21 Sup. Ct. 557, 45 L. Ed. 814; *Bardes v. Bank*, 178 U. S. 524, 20 Sup. Ct. 1000, 44 L. Ed. 1175; *In re Purvine*, 37 C. C. A. 446, 96 Fed. 192. But what are the limits of this summary jurisdiction? Must the court stay its hand upon the mere ascertainment that money belonging to the bankrupt's estate is in the possession of a third party? Or should it inquire into the nature of the possession, and govern its action accordingly? Upon these questions the cases of *Mueller v. Nugent* and *Trust Co. v. Comingor* are instructive. In the former it was said by the court:

"The bankruptcy court would be helpless, indeed, if the bare refusal to turn over could conclusively operate to drive the trustee to an action to recover as for an indebtedness or a conversion, or to proceedings in chancery, at the risk of the accompaniments of delay, complication, and expense, intended to be avoided by the simpler methods of the bankrupt law. It is as true of the present law as it was of that of 1867 that the filing of the petition is a caveat to all the world, and in effect an attachment and injunction (*Bank v. Sherman*, 101 U. S. 403, 25 L. Ed. 866); and, on adjudication, title to the bank-

rupt's property became vested in the trustee (sections 70, 21e [U. S. Comp. St. 1901, pp. 3451, 3430]), with actual or constructive possession, and placed in the custody of the bankruptcy court. There was no pretense that at the date of the filing of this petition in bankruptcy this money of the bankrupt, \$4,133.45 of which had been collected a few days, and \$10,100 a few hours, before, was held subject to any adverse claim, or that the right or title thereto had been passed over to another. The position now taken amounts to no more than to assert that a mere refusal to surrender constitutes an adverse holding in fact, and therefore an adverse claim when the petition was filed, and, to that we cannot give our assent. But suppose that respondent had asserted that he had the right to possession by reason of a claim adverse to the bankrupt. The bankruptcy court had the power to ascertain whether any basis for such claim actually existed at the time of the filing of the petition. The court would have been bound to enter upon that inquiry, and in doing so would have undoubtedly acted within its jurisdiction, while its conclusion might have been that an adverse claim, not merely colorable, but real, even though fraudulent and voidable, existed in fact, and so that it must decline to finally adjudicate on the merits. If it erred in its ruling either way, its action would be subject to review."

And in the latter:

"The question is whether the district court had jurisdiction to finally adjudicate the merits in this proceeding. We have just held, in *Mueller v. Nugent*, 184 U. S. 1, 22 Sup. Ct. 269, 46 L. Ed. 405, that the district court has power to ascertain whether in the particular instance the claim asserted is an adverse claim existing at the time the petition was filed. And according to the conclusion reached, the court will retain jurisdiction or decline to adjudicate the merits."

From a careful examination of the two cases last referred to, the court is of the opinion that the district court, as a court of bankruptcy, has power in a summary way to ascertain whether in the present case the claim of the bank was a real adverse claim existing against the bankrupts at the time the involuntary petition was filed against them. And if the bank did not at that time claim adversely the money held by it pursuant to the receipt executed by its cashier, the referee had the power to summarily order the bank to pay it over to the trustee for distribution among the bankrupts' creditors. The question then seems to be reduced to one of fact, which should be answered by the record. Briefly stated, the facts upon this point are as follows: Certain creditors filed their petition in bankruptcy against the firm of J. R. Davis & Co. on June 9, 1902. They were adjudged bankrupts July 7, 1902, and the trustee of the estate qualified on the 1st day of August following. On or about May 21, 1902, J. R. Davis & Co. sold their stock of merchandise to Drake for \$3,572.03, and on May 28th Drake and Hardin (the latter representing J. R. Davis & Co.) deposited the full amount with the First National Bank of Morgan, taking therefor a receipt from the bank which expressed upon its face that the money was to be prorated among the creditors of J. R. Davis & Co. as their interests might appear. At the date of the deposit, J. R. Davis & Co. owed the First National Bank of Morgan about the sum of \$2,486.75, evidenced by several promissory notes, none of which became due until on or about August 1, 1902, the date of the qualification of the trustee. On May 28, 1902, J. R. Davis & Co. were indebted to the Bank of Morgan in a sum somewhat exceeding \$3,000, as evidenced by certain promissory notes, in which the First National Bank of Morgan had no interest. On July 9, 1902, the First National Bank,

without the consent of Drake or of the bankrupts, and without notice to either, appropriated the \$3,572.03 deposited with it by applying about \$1,550 of the amount as a credit on the indebtedness of the bankrupts to it, and the remainder as a credit on the notes held by the Bank of Morgan. And the referee finds as a fact (a conclusion, it may be said, having ample justification in the record) that the First National Bank of Morgan asserted no adverse claim to the money deposited with it until the date of its appropriation as above stated, which was one month subsequent to the filing of the petition in bankruptcy, and two days after the order of adjudication. Applying, then, the principle of law announced by the court in *Mueller v. Nugent*, and *Trust Co. v. Cominger*, supra, to the facts of the case before the court, the action of the referee in summarily requiring the payment of the money by the bank would appear to be proper, since at the date of the filing of the bankruptcy petition no adverse claim to the fund was asserted by the bank.

But upon the merits of the controversy, would the bank be in a position to successfully contest the right of the trustee to the money? Its ability to do so would depend upon its right to apply the fund to its own use. While a general deposit by a merchant of money in a bank creates the relation of debtor and creditor, and authorizes the bank to use the money as its own, such result does not obtain when the deposit is made for a special purpose,—as, for example, to be paid to creditors, as was the case here. In the latter case a fiduciary relationship is created, and the money is held as a trust fund, not as bank assets, and hence the bank is without lawful right to appropriate it to its own use. In *Peak v. Ellicott*, 30 Kan. 161, 162, 1 Pac. 501, 46 Am. Rep. 90, the principle is so clearly stated that nothing need be said by way of elaboration. Speaking for the court in that case, Mr. Chief Justice Horton said:

"The question in this case is whether a trust in favor of the plaintiff is impressed upon the \$782.50 delivered to the cashier of the Riley County Bank on November 22, 1881, for the purpose of paying the note of the plaintiff executed to the bank, but at that time owned and held by the Harrison National Bank of Cadiz, in Ohio. When the bank, through its cashier, accepted the \$782.50, it was not paid by the plaintiff as a deposit, nor accepted by the latter as a deposit; nor was the relation of debtor and creditor between the bank and the plaintiff created by the transaction. On the other hand, as respects this specific sum, the relation between the plaintiff and the bank must be regarded as that of principal and agent. After the bank received this sum to satisfy the note of the plaintiff, the bank held the money in a fiduciary capacity. If the money was not applied, according to the understanding of the parties, to the satisfaction of the note, it should have been returned to the plaintiff. It was not deposited to be checked out, or to be loaned or otherwise used by the bank: in law the bank held it as a trust fund, and not as the assets of the bank. The defendant, as assignee of the bank, succeeds to all the rights of the bank, but as such assignee he has no lawful authority to retain a trust fund in his hands belonging to the plaintiff, and which the bank at the time of receiving the same promised and agreed to apply in payment of plaintiff's note. As the money was a trust fund, and never belonged to the bank, its creditors will not be injured if it is turned over by the assignee to its owner. Even if the trust fund has been mixed with other funds of the bank, this cannot prevent the plaintiff from following and reclaiming the fund, because, if a trust fund is mixed with other funds, the person equitably enti-

tled thereto may follow it, and has a charge on the whole fund for the amount due. *Frith v. Cartland*, 2 Hen. & M. 417, 420."

See, also, *Libby v. Hopkins*, 104 U. S. 303, 26 L. Ed. 769; *Central Nat. Bank v. Connecticut Mut. Life Ins. Co.*, 104 U. S. 54, 26 L. Ed. 693; *Reynes v. Dumont*, 130 U. S. 354, 9 Sup. Ct. 486, 32 L. Ed. 934; *Montagu v. Bank (C. C.)* 81 Fed. 602; *Bank v. Weems*, 69 Tex. 489, 6 S. W. 802, 5 Am. St. Rep. 85; *Wilson v. Dawson*, 52 Ind. 513; *Zane, Banks & Banking*, §§ 136, 341; 3 Am. & Eng. Enc. Law (2d Ed.) p. 822, and authorities cited.

In *Wilson v. Dawson*, 52 Ind. 515, the court stated the principle in the following language:

"It is a general rule that funds deposited in a bank for a special purpose, known to the bank, cannot be withheld from that purpose, to the end that they may be set off by the bank against a debt due to it from the depositor. The claim of a general lien by the bank would be inconsistent with its special undertaking. *Morse, Banks & Banking*, 34 et seq., and authorities cited; *Bank v. Macalester*, 9 Pa. 475."

From the authorities cited, the conclusion is plain that the deposit made by the bankrupts with the First National Bank of Morgan should be treated as a special deposit for the benefit of the bankrupts' creditors, and not as a general deposit. The bankrupts retained their title to the fund for the particular purpose specified in the receipt executed by the bank, until the order of adjudication was passed, from which date the title became vested in the trustee thereafter appointed. Hence the fund was not adversely held by the bank, its possession being in the nature of an agency, the status attributed by the supreme court to an assignee under a deed of assignment (*Bryan v. Bernheimer*, supra), and the referee acted within his jurisdiction in issuing the order requiring the agent to pay the fund over to the trustee for the benefit of the estate which he represented.

It is further objected that interest is not recoverable in a proceeding of this nature. In *Central Nat. Bank v. Connecticut Mut. Life Ins. Co.*, and *Peak v. Ellicott*, supra, interest was allowed; but those were plenary suits, in which judgments rendered for money are usually enforced by the levy of executions, and not summary proceedings in bankruptcy, where the penalty of disobedience is punishment for contempt. The bankruptcy act is silent upon the subject, and counsel have submitted no authorities pertinent to the inquiry; nor has the investigation made by the court disclosed a case where the payment of interest has been enforced in a proceeding of this nature. While, therefore, not altogether satisfied with the conclusion reached, the court is of the opinion that an order of the referee in a case like the present should not include interest on the amount withheld. The order of the referee will consequently be amended by eliminating the item of interest. And an order will be entered requiring the First National Bank of Morgan to pay over to the trustee in bankruptcy the sum of \$3,572.03 on or before January 26, A. D. 1903.

ELKINS v. CITY OF CHICAGO et al. (two cases).

(Circuit Court, N. D. Illinois, N. D. May 8, 1902.)

1. FEDERAL COURTS — JURISDICTION — DIVERSITY OF CITIZENSHIP — SUIT BY STOCKHOLDER.

In a bill filed in a federal court by a stockholder to enforce rights which may properly be asserted by the corporation, allegations which do no more than to show a formal demand on the board of directors to bring the suit, and a formal refusal, with a further general allegation that the suit is not a collusive one to confer jurisdiction, are not a sufficient compliance with equity rule 94; and the court is without jurisdiction on the ground of diversity of citizenship where the corporation which is made a defendant is, for jurisdictional purposes, a citizen of the same state as the other defendants.

2. SAME — FEDERAL QUESTION — THREATENED LEGISLATION IMPAIRING CONTRACT.

Under the settled doctrine that the courts can only deal with the question of the constitutionality of a legislative act after it has been passed, and are without jurisdiction to interfere with proposed or pending legislation, either state or municipal, the action of a city council in adopting the report of a committee finding that the franchise of a street railway company will expire at a certain time, contrary to the contention of the company, and recommending that the council take measures to dispossess the company at the expiration of such time unless there is a previous renewal, does not give a federal court jurisdiction of a suit to determine the controversy between the company and the city in respect to the term of the grant, on the ground that it presents a constitutional question as to the impairment of the contract rights of the company.

3. EQUITY — AMENDMENT OF BILL.

A city ordinance requiring a street railroad company to give transfers from one to another of two railway systems, both of which it operated as lessee, does not give any right of action against the city in favor of a stockholder of one of the lessor companies, where it does not appear that such company has any interest in the receipts of the lessee, and an amendment setting up such ordinance is not germane to a bill by the stockholder based upon an alleged impairment by the city of the contract rights of the lessor company under its franchise.

In Equity. On demurrer to bill for want of jurisdiction.

Henry Crawford, John S. Miller, and W. R. Crawford, for complainant.

Charles M. Walker and Shope, Mathis, Zane & Weber, for defendant city.

John A. Rose, for defendant railroad companies.

SEAMAN, District Judge. The complainant has filed two bills, as stockholder,—one for his interest in the Chicago West Division Railway Company, and the other for his interest in North Chicago City Railway Company,—against the city of Chicago and the companies, respectively, and their respective lessees, as defendants; and each bill alleges a controversy concerning the duration of the charters and property rights of such companies in the operation of their sys-

¶ 1. Diverse citizenship as ground of federal jurisdiction, see notes to *Shipp v. Williams*, 10 C. C. A. 249; *Mason v. Dullaghan*, 27 C. C. A. 298.

¶ 2. Jurisdiction in cases involving federal question, see notes to *Balley v. Mosher*, 11 C. C. A. 308; *Montana Ore Purchasing Co. v. Boston & M. C. C. & S. Min. Co.*, 35 C. C. A. 7.

tems of street railways in Chicago. The subject-matter is plainly of equitable cognizance, and an early determination of the controversy by a court of competent jurisdiction is of the utmost importance for all interests, public and private. That the state courts have ample jurisdiction for all the purposes of the bill is unquestioned, but the complainant is nevertheless entitled to the exercise of concurrent power vested in this court for an adjudication of the controversy, if brought within the limitations of federal jurisdiction. The demurrer challenges the sufficiency of the allegations of the bill to that end, and thus the only question to be considered is whether the case is presented within either of the grounds of federal cognizance: (1) On the requisite diverse citizenship of parties; or (2) as a case arising under the constitution of the United States,—testing the allegations in each view by the well-recognized presumptions against jurisdiction and against the pleader.

1. Diverse citizenship of the parties appears as they are arranged by the bill,—the complainant being a citizen of Pennsylvania, while each of the defendants is an Illinois corporation,—but such an arrangement is not controlling for the present inquiry, in any aspect of the case. It is the duty of the court, for jurisdictional purposes, to ascertain the necessary parties to the suit, and align them upon the one side or the other in conformity with their true interests and attitude, irrespective of their designations in the bill. So considered, the interests of the complainant, as stockholder of the charter corporation, and of the corporation itself, are entirely identical, and, aside from any question as to the interests of the lessee or operating corporations named as defendants, such status is a bar to jurisdiction based alone on diversity of citizenship, unless compliance with equity rule 94 appears in the allegations of the bill, and saves the case from the general doctrine of alignment of parties. The complainant sues, in the capacity of stockholder, to enforce “rights which may properly be asserted by the corporation,” and the action is governed by equity rule 94, which was adopted by the supreme court in 1881 to give effect to the principles declared in *Hawes v. Oakland*, 104 U. S. 450, 26 L. Ed. 827, in like case. The doctrine is well recognized that a stockholder in a corporation is entitled to relief in equity for the preservation of his interests against illegal or fraudulent management or action on the part of the corporation, and that such relief may extend as well to the protection of “the property and rights of the corporation against the action or threatened action of third parties” arising out of such conduct of the corporation. *City of Detroit v. Dean*, 106 U. S. 537, 541, 1 Sup. Ct. 560, 27 L. Ed. 300; *Hawes v. Oakland*, *supra*, and cases reviewed. But the incidental right to have the relief so extend over third parties cannot serve alone to invoke federal jurisdiction through the noncitizenship of the stockholder complainant, as the wholesome rule for the alignment of parties would then arise to determine the jurisdiction. Whether a case brought strictly within rule 94 avoids an alignment for that purpose of the corporation refusing to institute a suit with the complainant, suing as an injured stockholder, is a question not involved in the present inquiry, unless the complainant has met the requirements of such rule; and

the sufficiency of his allegations in that regard remains to be considered. Respecting the alleged controversies between the street railway companies and the municipal authorities, it may be assumed, for this point, that its nature would authorize suit on behalf of stockholders for its settlement in the event of refusal on the part of the corporation to bring the action, on the general principles of equity. Vide *Dodge v. Woolsey*, 18 How. 331, 15 L. Ed. 401. But equity rule 94 imposes further conditions upon the stockholder to maintain such action in the federal court. By way of compliance with these conditions, the allegations are that the complainant is a stockholder,—the period of such interest not stated,—and, as such, “made demand of the board of directors of said corporation” to institute legal proceedings to the end sought by the bill, and that they notified him that the company “declines and refuses to comply with such demand,” or to bring suit to establish title or protect the franchises, “and leaves complainant to take such action as he may be advised”; and it is further averred that “this suit is not a collusive one to confer on this court jurisdiction of a case of which it would not otherwise have cognizance.” These mere general averments are plainly evasive and insufficient for the purposes indicated by the rule, and in no sense meet the requirements pointed out in the decisions thereunder. *Hawes v. Oakland*, supra; *Huntington v. Palmer*, 104 U. S. 482, 26 L. Ed. 833; *Greenwood v. Railroad Co.*, 105 U. S. 13, 26 L. Ed. 961; *City of Detroit v. Dean*, 106 U. S. 537, 1 Sup. Ct. 560, 27 L. Ed. 300; *City of Quincy v. Steel*, 120 U. S. 241, 7 Sup. Ct. 520, 30 L. Ed. 624. The “earnest and persistent efforts” on the part of the stockholder to induce action by the directors, and “an honest effort to obtain action by the stockholders as a body” to bring about such result, “if time permits or has permitted,” are not “made apparent to the court,” as required by the authorities cited; and the utmost effect of the allegations is to show a formal demand and a formal refusal, with no circumstances stated to indicate that either demand or refusal were other than perfunctory. The statement that the “suit is not a collusive one to confer jurisdiction” does not meet this objection to the alleged demand and refusal, nor serve to show that either “was not simulated, but real and persisted in.” *City of Detroit v. Dean*, supra. I am of opinion, therefore, that the allegations of the bill do not sustain jurisdiction on the ground of citizenship; and, in this view, the alleged want of verification in conformity with the intention of the rule is not material, if otherwise open to demurrer.

2. Jurisdiction is asserted, however, on the ground that the bills present a federal question, and on the further contention that the ninety-fourth rule is not applicable in such case. Is the case stated by the bill one arising under the constitution of the United States, within the meaning of the jurisdictional provision? The grants set forth are charter and property rights and privileges in the streets of Chicago, conferred upon the companies by the state, both in direct legislative acts and through ordinances of the city, and the duration and other terms of the rights so vested must be ascertained through an interpretation of these grants. Contract or property rights which are thereby vested in the companies cannot be divested without their

consent, and subsequent legislation by the city or state which impairs or takes away such rights violates the constitution of the United States; and a suit which is founded on a violation so alleged is one of which federal courts "have original cognizance, concurrent with the courts of the several states" (25 Stat. 433, c. 866 [U. S. Comp. St. 1901, p. 508]), as "arising under the constitution and laws of the United States." As remarked in *City of Detroit v. Detroit Citizens' St. Ry. Co.*, 184 U. S. 368, 382, 22 Sup. Ct. 410, 416, 46 L. Ed. 592:

"The contract once having been made, the power of the city over the subject, so far as altering the rates of fare, or other matters properly involved in and being part of the contract, is suspended for the period of the running of the contract."

The issue of inviolability of the contract, on the one hand, and of impairment or recall, on the other, necessarily depends on an interpretation of both legislative actions, and the fact that it so depends cannot oust the federal jurisdiction. While the state courts possess jurisdiction, in a case before them, to interpret such legislation, and to decide as well whether the United States constitution is thereby violated, their jurisdiction is concurrent only, and not exclusive for either inquiry; and the contention by counsel for the defendant city that it is their exclusive province to construe state legislation is neither supported by the authorities referred to, nor tenable as a test of federal jurisdiction. The cases cited on the argument and in the briefs for and against cognizance of the present case, as one arising under the constitution, cover the various phases in which that question is presented, whether on writs of error to the state courts, or in cases originating in the federal court, or in removal cases; and, while all are instructive, the difficulty in solving the inquiry raised by this bill cannot be met by resting on general definitions and expressions which appear in one or the other of the opinions. The decisions of the supreme court upon the general subject are numerous, and are, of course, controlling when in point. An examination of the long line which appears applicable to the case set forth in the bill fully confirms my impression at the close of the oral argument, namely, that the decisions concur in the view above expressed, and that a case which presents interference on the part of the state, or by the municipality as its delegate, with the vested property or contract rights of the citizen, is within the federal jurisdiction. But the same authorities further concur in upholding the rule of strict construction in such cases, and thereupon that violation of the constitution must appear in legislative impairment of the contract, or in taking property without due process through legislative action; that "jurisdiction cannot be assumed on a mere hypothesis" (*City of New Orleans v. Benjamin*, 153 U. S. 411, 424, 14 Sup. Ct. 905, 38 L. Ed. 764), and the case must be one "actually and not potentially arising" under the constitution; and finally that jurisdiction cannot be invoked for threatened legislative action, or to interfere in any manner with the adoption of such action by state or city (*McChord v. Railway Co.*, 22 Sup. Ct. 165, 170, 46 L. Ed. 289).

Under the doctrine so established, I am of opinion that the alleged action on the part of the city, however injurious to the interests of

the complainant, is not within the jurisdiction of this court. The strong case averred of charter and contract rights vested in the companies, which stands conceded for the purposes of this hearing, furnishes no ground for federal jurisdiction, in the absence of infringement recognized as such by the federal law. Of the ordinance of 1883, referred to in the argument for complainant as legislative infringement, it is sufficient to remark that it is not so averred in the bill, but appears as a provision for special matters not previously agreed upon, and both adopted and accepted as such for the term stated, and that the ordinance expressly provides that it shall not "in any manner impair, change or alter the existing rights, duties and obligations" of either party after the expiration of the specified time. The real cause of complaint, however, is one of serious controversy between the municipal authorities and the companies respecting the term for which the grants extend. A committee appointed by the common council to act with the mayor for such investigation reported at length their conclusions, and the grounds thereof,—in effect, that all such rights and privileges would terminate in 1903,—and then recommended the adoption of measures to dispossess the companies at the expiration of the time so reported if renewal was not arranged meantime; and the bill charges that such report was "received, approved, and printed" by the common council, and that it is the purpose of the city to adopt measures and proceed for their enforcement in conformity with the recommendation so reported and "approved." But no action has been taken by the common council beyond the alleged treatment of the report, and, without the adoption of some measure to carry the recommendations into effect, the alleged approval amounts, at the utmost, to a mere expression of opinion; and, however seriously a controversy so presented may affect the credit or other interests of the companies, it is not legislative violation of constitutional rights, within any authority called to my attention, and cannot be so treated under the well-established doctrine that no judicial interference with proposed or pending legislation, state or municipal, is tolerated. The recent case in the supreme court of *Vicksburg Waterworks Co. v. Mayor, etc.*, of City of Vicksburg (decided April 7, 1902) 22 Sup. Ct. 585, 46 L. Ed. 808, clearly exemplifies the distinction upon which the present ruling is based. Jurisdiction was upheld in that case for legislative impairment of the existing contract obligation between the city and the waterworks company, which appeared in three elements: (1) An act of the legislature authorizing the city to issue bonds to purchase or construct waterworks; (2) a resolution or ordinance of the city denying further obligation to the old company; and (3) subsequent action by the city in holding an election for the issue of bonds as authorized, and in refusing to pay the amount due and payable under the terms of the ordinance contract. As stated in the opinion, these acts, taken together, "do not present the mere case of a breach of a private contract, to be remedied by an action at law, but disclose an intention and attempt, by subsequent legislation of the city, to deprive the complainant of its rights under an existing contract."

At the opening of the oral argument an amendment to the bill was tendered on behalf of the complainant, and the objection made to its

allowance as not germane, but ruling thereupon was reserved. It sets up an ordinance adopted April 8, 1897, which provides for compulsory transfers, and appears to be made operative only upon the Chicago Union Traction Company, named defendant in each bill as "lessee and operating agent" of the charter companies, respectively,—appearing in fact as the lessee of both systems,—and transfers are required only for passage from one original system over the other when both are owned or operated by the same company; in other words, treating the several systems so joined in one lessee as a unit. How such provision affects the rights or interests of the individual lessor is not disclosed in the proposed amendment, nor are the terms of the lease disclosed. In the absence of allegations to show injury to the lessor companies, I am of opinion that it is not germane to the controversy set up in the original bill, and that it surely furnishes no aid to the case of complainant as stockholder of the lessor company. Doubtless the lessee of the properties so joined in its possession must operate each under the respective charters, and may enjoy the rights thereof and be protected thereunder, and may be entitled to concurrence on the part of the lessor in a proper suit for such protection, if necessary. But the general averment of the fact of leasing, with no allegation to show that the lessor retained or held an interest in the operation and earnings under the lease and in the combined arrangement, raises a presumption, under well-settled rules of pleading, that no such interest remains in or is held by the lessor, to be protected by the stockholder in this suit. While lessor and stockholder may be vitally interested in the controversy touching the charter life and rights, as affecting re-entry and reversion, for which either may invoke protection, nevertheless an independent controversy between such lessee and the city, which concerns only operation and earnings under the leases so united in the lessee corporation, and does not affect the lessor, if germane, in any sense, to a bill filed by either corporation, is foreign to any interest disclosed in this complainant, and cannot be brought in on his behalf by way of amendment to his original bill,—certainly not to confer jurisdiction, through its subject-matter, not conferred by the subject-matter of the bill filed.

The demurrers must be sustained.

PRINGLE v. GUILD et al.

(Circuit Court, D. South Carolina. January 14, 1903.)

1. NEW TRIAL.—GROUNDS—MATTERS CONCLUDED BY VERDICT.

Where there is a conflict of testimony between unimpeached witnesses on an issue, it is the province of the jury to determine such issue, and the court is not authorized to set aside their verdict, although it may believe the preponderance of evidence to be the other way.

At Law. On motion for new trial.

Wm. H. Lyles and D. W. Robinson, for plaintiff.

R. W. Shaud and P. H. Nelson, for defendants.

SIMONTON, Circuit Judge. This case now comes up on a motion for a new trial by the defendants. J. S. Guild and George M. Guild, the defendants, were under contract with the city of Columbia for the construction of a sewerage system in said city. To this end, they were authorized to open ground in the city, and make excavations necessary for the work. Among other places, the defendants constructed a tunnel on Indigo street, under the main track and siding of the Atlantic Coast Line Railway, and, for the purposes of the tunnel, dug a shaft or hole between these tracks; the said shaft or hole being at the opening some 5 feet in length, 4 feet wide, and 14 or 15 feet deep. The excavation along Indigo street completely cut off approach to the sidewalk, with a bank of earth of considerable size, through which there were three openings, so that passengers might cross from one side of the street to the other. One of these was across the tracks of the Atlantic Coast Line, alongside of this shaft or hole; the passage across being some 22 feet wide. On the night of 4th August, 1902, Robert S. Pringle who lived in Indigo street, at a point very near to this passage, crossed from the side of Indigo street opposite to his home, and pursued his way along this passage. He fell into this hole or shaft, and in the fall suffered injuries from which he shortly afterwards died. Thereupon his widow and administratrix brought this action under the provisions of the Code of South Carolina (sections 2851 and 2852) giving a right of action to the personal representative of a deceased person whose death resulted from the negligence of another. The case was tried before a jury, much testimony having been introduced on each side; and at the close of the testimony the jury were sent to the locus in quo, so that by personal observation they could understand the case. The trial was conducted on both sides with marked ability, and nothing of a sensational character was introduced into it. After full argument, the case was submitted to the jury, the points of law were distinctly stated by the trial judge, and the solution of the issues of fact was submitted to the jury. They found for the plaintiff \$5,000. Notice of a motion for a new trial was given at the rendition of the verdict. The motion has now been heard on the following grounds: (1) Because said verdict, under the law of the case, as charged by his honor, was capricious and unsupported by the evidence. (2) Because the uncontradicted testimony established the facts that R. S. Pringle knew of the existence, location, and dangerous depth of the hole into which he fell; knew at the time of his fall that he was crossing Lincoln street just where the hole was; and the precise location of the hole was manifested by the light of the street arc light. (3) Because the overwhelming weight of the testimony showed that at the time of Pringle's fall a red lantern was standing and burning on the edge of the hole into which he fell,—an all-sufficient warning to him of its danger, if he had used his senses. (4) Because, from the testimony, R. S. Pringle was himself negligent, and such negligence contributed to such injury. Therefore plaintiff was not entitled to a verdict.

There were two issues presented to the jury. They were instructed that it was the duty of the defendants to take all reasonable precaution to prevent injury to the passers-by by reason of the existence of this

hole or shaft. They were also instructed that, if they came to the conclusion that there was negligence on the part of the defendants in this behalf, yet if Robert S. Pringle himself did not exercise ordinary care, and by reason thereof was injured, the plaintiff could not recover.

It appeared that the defendants contended that a red lamp had been placed alongside of the hole on the night and at the time of the accident, and that this was a reasonable and proper precaution. On this point there was conflict of evidence. The defendants introduced a number of witnesses who swore positively to the fact that the red lamp was in position before and up to the time of the accident. The plaintiff producing a few witnesses who were as positive in assertion that the lamp was not there. The high character of these witnesses was admitted. The attention of the jury was called to this conflict, and they were instructed to solve it. The character of none of the witnesses was impeached.

Under section 726, Rev. St. U. S. [U. S. Comp. St. 1901, p. 584], federal courts have power to grant new trials for reasons for which new trials have been usually granted in the courts of law, or, in the language of the seventh amendment to the constitution of the United States, "no fact tried by a jury shall be otherwise re-examined in any court of the United States, than according to the rules of the common law." The action of the court is not reviewable. New trials at law are granted when the trial court erred in stating the law, or when the verdict of the jury has no evidence to sustain it, or when the great preponderance of the evidence is against the verdict, or when the verdict is due to passion, prejudice, or partisan feeling. In the present case there was evidence on the part of the plaintiff. So the question is as to the preponderance of the evidence. In *Pim v. Wait* (C. C.) 32 Fed. 741, it was held that, when the evidence on an issue tends to support the views of each party, a new trial will not be granted on the ground that the verdict is against the weight of evidence. In *Nonce v. Railroad Co.* (C. C.) 33 Fed. 429, it was held that when the evidence is conflicting, and the witnesses are of good character, the verdict, if not manifestly wrong or improperly obtained, ought not to be set aside. And this rule prevails even though the court might have rendered a decision different from that of the jury. *Plummer v. Mining Co.* (C. C.) 55 Fed. 755; *Sargent v. Association* (C. C.) 35 Fed. 712. The supreme court of the United States, in *Pleasants v. Fant*, 22 Wall. 121, 22 L. Ed. 780, discusses this subject:

"It is the duty of a court, in its relation to the jury, to protect parties from unjust verdicts, arising from ignorance of the rules of law and of evidence, from impulse of passion or prejudice, or from any other violation of their lawful rights in the conduct of a trial. This is done by making plain to them the issues they are to try; by admitting only such evidence as is proper in these issues, and rejecting all else; by instructing them in the rules of law by which that evidence is examined and applied; and finally, when necessary, by setting aside a verdict which is unsupported by evidence or contrary to law. In the discharge of this duty, it is the province of the court, either before or after the verdict, to decide whether the plaintiff has given enough evidence to support or justify the verdict. Not whether on all the evidence the preponderating weight is in his favor. That is the business of the jury. But conceding to all the evidence offered the greatest probative force which, according to the law of evidence, it is fairly entitled to, is it sufficient to justify a verdict? If it does not, then it is the duty of the court, after a verdict,

to set it aside and grant a new trial. In determining a motion for a new trial, the court can—indeed, must—consider the preponderance of the evidence, and, if it clearly appears that the weight of the evidence is against the verdict, a new trial should be granted. *Felton v. Spiro*, 47 U. S. App. 402, 24 C. C. A. 321, 78 Fed. 576. The rule at common law is stated in *Carstairs v. Stein*, 4 Maule & S. 192. There the court refused a new trial where the evidence was conflicting, not satisfactory, and contrary to the intimations of the trial judge. It was held that a verdict should be sustained unless it appears clear that the jury had drawn an erroneous conclusion. The court, in granting new trials, does not interfere unless to remedy some manifest abuse, or to correct some manifest error in law or fact.”

The evidence in the case at bar has been carefully considered. The whole of this part of the case turns upon the credibility of the witnesses, or more properly upon the weight which the jury gave to the testimony of the witnesses. There was a direct conflict. This conflict the jury solved. The matter was entirely within their peculiar province. “It is the peculiar province of the jury to determine the credibility of the witnesses and weigh the evidence. A verdict will not be set aside merely because the court, if trying the question of fact, would have found differently. A verdict must be manifestly and palpably wrong, to justify a new trial.” 14 Enc. Pl. & Prac. p. 772.

The charge of the court was in these words:

“The ordinances of the city provided that, when excavations were made, suitable barriers should be placed around them, and sufficient danger signals maintained at night, to prevent accidents to street passengers. This must be done in every case in which such barriers are possible. If it was impossible to put up barriers, then some other means must be substituted, equally efficient, to give the public notice that an excavation exists, and enable them to avoid it. The end to be subserved was notice—ample notice—to the public that an excavation exists. If such notice is given, then the purpose is subserved. Now, you will examine the testimony, and decide: (1) Was it necessary to excavate the hole into which Mr. Pringle fell? You may assume that it was necessary, there being no evidence to the contrary. (2) The hole being there, on a path used by the public, did the defendants, their agents or servants, take all needful, proper, and reasonable precautions to give notice of its existence? They did not put a barrier around it. It is said, because of its peculiar proximity to the railroad track, a barrier around the hole was impossible. This you must determine. If it was impossible to put up such a barrier, did the defendants substitute another means of precaution, equally good? Did they have a red lamp at the hole? On this point there is conflict of evidence. This you must solve, and you alone. You have seen and heard the witnesses, and your conclusion depends upon your belief of these witnesses. If you believe that there was a red lamp at this hole, was this an efficient substitute, and did it give sufficient notice, aided by other lights,—notably, the arc light in that vicinity? Were those lights there at the time of the accident? If the lamp was at that hole, if it was burning, if it was ample and sufficient notice of the hole, a good substitute for a barrier or other mode of precaution, then you can find that defendants were not negligent. But if you find either that the lamp was not there, or that it was not burning, or, if it was, that it was not sufficient notice,—nor a proper substitute for any other mode of notice,—then you can find the defendants negligent.”

Under this charge the jury found their verdict for the plaintiff. It would be an invasion of the province of the jury to set the verdict aside, for it can be sustained on a correct theory, applicable to the facts, if the jury believed the witnesses for the plaintiff. “When it can be seen that the jury was warranted in inferring a state of case that would admit of a verdict, the judgment should be upheld, although it seems to be against the preponderance of evidence. The prevailing

party is entitled to all inferences legitimately arising from the finding." Bloomer v. Denman, 12 Ill. 240.

The jury were further instructed that, even if they found defendants negligent, they could not find for the plaintiff if the deceased intestate was wanting in ordinary care, and for want of such care fell into the hole. The facts bearing on this question were fully discussed before the jury. No one saw him approaching the hole, or saw him fall in. Whether he exercised ordinary care, or not, is a matter of inference; and the strongest argument for the position that he did not exercise ordinary care is that he fell into the hole, the existence and location of which he knew. But this argument loses much of its strength if the jury were right in finding defendants negligent in not using proper precaution to notify the public. The jury, by their verdict, clearly showed that they did not think Mr. Pringle guilty of contributory negligence.

Reviewing the whole case, the court does not feel at liberty to reverse the finding of the jury. The motion for a new trial is dismissed.

TAYLOR GAS PRODUCER CO. v. WOOD.

(Circuit Court, E. D. Pennsylvania. January, 20, 1903.)

No. 30.

1. CORPORATIONS—CONTRACTS—IMPLIED RATIFICATION.

The board of directors of a corporation which had granted a license under a patent owned by the company, by which the licensee agreed to pay royalty on a minimum number of the patented articles per annum, adopted a resolution appointing a committee to consider amendments to the contract, and providing that the same should be held in abeyance, owing to the doubt as to the validity of the patent and the amount of infringement going on. It also provided that the contract should be modified as agreed upon between the committee and the licensee. The correspondence between the president of the company, as a member of the committee, and the licensee, warranted the submission to the jury of the question whether a modification of the contract with respect to royalties was agreed on. *Held*, that a ratification of such modification by the directors, which would be binding upon the company, might be implied from their subsequent course of conduct, although no formal ratification was made.

At Law. On motion for judgment non obstante veredicto.

Henry E. Everding and Alex. Simpson, Jr., for plaintiff.
Joseph C. Fraley, for defendant.

DALLAS, Circuit Judge. This action was brought upon an agreement in writing dated September 11, 1890, by and between the plaintiff and the defendant, whereby the defendant was licensed to make and vend gas producers or apparatus for making gas under several letters patent owned by the plaintiff. After prescribing the license fees to be paid upon the gas producers which should be actually manufactured, the agreement provided:

"Third. That furthermore, in consideration of the license aforesaid, the said Walter Wood, party hereto of the second part, hereby agrees to make

and sell, or cause or procure to be made and sold, to others, to be used after the third and during each subsequent year of this license and agreement, not less than one hundred gas producers, or apparatus for making gas, containing or embodying the inventions set forth or described and claimed in the said hereinbefore recited several letters patent, or account for and pay royalty to the said corporation, the Taylor Gas Producer Company, party hereto of the first part, in each and every year after third from the date of this license and agreement, a royalty or license fees on not less than one hundred gas producers, or apparatus for making gas, containing or embodying the inventions set forth or described and claimed in the hereinbefore recited several letters patent, or some of them, whether that number of gas producers, or apparatus for making gas, or not, has or have been made by the said Walter Wood, party hereto of the second part, or by his procurement or authority, during that year."

Under this clause of the contract the plaintiff claimed to recover the sum of \$10,000, being \$25 per producer upon 100 producers, for each of the years 1898, 1899, 1900, and 1901; and the defense, so far as now material, was that that clause had been abrogated or waived by subsequent agreement of the parties. It was—

"Agreed between counsel for plaintiff and defendant that if the court shall, upon a review of the entire evidence produced on the trial held November 13, 1902, be of opinion there is not sufficient evidence to submit to the jury the question as to whether or not the clause of the contract in suit relative to the minimum amount of royalties to be paid has been abrogated or waived by agreement of the parties, expressed or implied, that then the verdict, if for the defendant, is to be changed to a verdict for the plaintiff for the amount claimed, as if upon an instructed verdict to the jury to that effect, reserving to each party the right to an appeal or writ of error as to the correctness of the ruling of the court on this and all other points in the case. This stipulation is entered into in order to avoid difficulty on the question of practice which forbids a judgment for plaintiff non obstante veredicto despite a finding by the jury for the defendant."

Subject to this stipulation, the question therein stated was submitted to the jury, with instructions to which no objection has been made; and, a verdict for defendant having been rendered, the plaintiff, in accordance with the terms of the stipulation, has now moved for judgment in its favor non obstante veredicto.

Whether or not rule 22, if duly invoked, would have precluded the defense under consideration, need not be determined, for I am clearly of opinion that at this stage of the case that rule is not operative. The evidence relating to this defense was fully gone into at the trial, and was referred to the jury upon an agreed reservation only of the question of its sufficiency; and a verdict rendered under such circumstances should not, I think, be set aside and reversed merely because a notice which might have been, but was not, insisted upon before its rendition, had not been given.

The plaintiff more pertinently contends that there was no evidence to go to the jury in support of the defendant's claim that "the clause of the contract in suit relative to the minimum amount of royalty to be paid had been abrogated or waived by agreement of the parties, expressed or implied." But I cannot affirm this proposition. The fact is that the jury did find that such an agreement had been made, and that finding, I think, was by no means one which could not reasonably have been based upon the evidence. It is true that the minutes of the plaintiff corporation exhibit no resolution of its

board of directors, or of its stockholders, directly and in express terms making the agreement in question, but it does not necessarily follow that it was not in fact made, and in such manner as to bind the company. The court of appeals for this circuit, in *Salem Iron Co. v. Lake Superior Consol. Iron Mines*, 50 C. C. A. 216, 112 Fed. 241, said:

"Undoubtedly the board of directors is generally the governing and controlling body of a corporation. Its policy and conduct, within the scope of the purpose of its creation, is in the absolute control of such directors. It cannot incur obligations without the consent of such board, or generally without its express authority; but the board of directors can exercise its plenary power by delegating its authority as to certain transactions or classes of transactions to its president or other executive officers, as well as by direct authorization of a particular transaction by express resolution to that effect. A corporation is an intelligent, though artificial, person; and while its board of directors is its controlling mind, it may be bound, like a natural person, by a consent implied by law from a course of conduct permitted and recognized by its governing body."

These observations are pertinent to the present case. At a directors' meeting held April 29, 1895, the president reported the sales of producers for the year 1894 (a "year after third from the date of this license and agreement"), showing license fees due thereon, but with no mention of minimum royalty, and from these fees the report stated that:

"Mr. Wood asks a reduction of \$410, so as to make the royalty conform to the royalty in force under the contract prior to October 3, 1893, in view of the uncertainty of the validity of the patent, and I now submit the same to the board for its action. * * * The question of the validity of the Taylor Producer patent is still unsettled, and considerable infringement is still going on."

Immediately following this report, the minutes record that:

"Messrs. E. B. Coxe, W. J. Taylor, and Walter Wood were appointed a committee for the prosecution of the parties infringing the patents owned or controlled by the company. This committee was also instructed to consider amendments to the contract with R. D. Wood & Co., the terms of which to be held in abeyance, owing to the doubt surrounding the patents, and to be modified as may be agreed upon subsequently between the committee and the licensees of the company under the said patents."

It seems, then, that at this meeting the attention of the board was distinctly directed to the fact that because the question as to the validity of the Taylor Producer patents was still unsettled, and considerable infringement was still going on, Mr. Wood asked a reduction of royalty to conform to the royalty in force under the contract prior to October 3, 1893, and that thereupon a committee was appointed, not only to consider amendments to the contract, but with power also to agree upon a modification thereof. That this action of the directors did not of itself amount to an agreement must be conceded, but it authorized the making of one, the consideration for which is quite apparent. The licensee supposed it to be the duty of his licensor to protect him against the competition of infringers, and, because this was not done, he claimed that the original contract should be changed. A question which both parties—the licensor as well as the licensee—conceived to be a serious one, was thus presented, and whether it was or was not actually a doubtful question

is unimportant, for, even if it were wholly free from doubt, its settlement would be a sufficient consideration to support a contract, made for that purpose. *Bank v. Geary*, 5 Pet. 114, 8 L. Ed. 60; *O'Keson v. Barclay*, 2 Pen. & W. 531.

It should not be overlooked that the board itself had agreed that, pending action by its committee, the terms of the original contract were "to be held in abeyance," and that some modification of it, the details of which the committee was to determine, would be made. But before anything was effected by the committee, one of its members (Mr. Eckley B. Coxe) died, and, his place not having been filled, it thereafter consisted of Mr. Taylor, the president of the company, and Mr. Wood himself. In the conversations and correspondence which ensued between these gentlemen, the former naturally spoke and wrote as representing the company; and the latter, quite as naturally, and not without warrant, assumed that he did represent it. I need not refer with particularity to what passed between them. It is sufficient to say that, while there was room for controversy as to whether they agreed upon an abrogation of the minimum clause of the contract, the evidence upon that question not only justified, but, in my opinion, required, its submission to the jury; and even if it were essential that such an agreement, when so made, should be subsequently ratified by the directors, their minutes disclose a course of conduct on their part from which, as it seems to me, such ratification may and ought to be implied. *Salem Iron Co. v. Lake Superior Consol. Iron Mines*, supra.

The plaintiff's motion for judgment non obstante veredicto is denied, and the clerk is directed to enter judgment for the defendant upon the verdict.

**NORTHROP et al. v. MERCANTILE TRUST & DEPOSIT CO. OF
BALTIMORE, MD.**

(Circuit Court, D. South Carolina. January 20, 1903.)

1. AMENDMENT OF COMPLAINT—CAUSE OF ACTION ARISING AFTER SUIT BROUGHT.

Under the Code of Procedure of South Carolina, the complaint, in an action for a breach of a contract, cannot be amended by alleging a second breach occurring after the action was commenced, and asking damages also for that.

2. CONTRACTS—RIGHT OF ACTION FOR BREACH—REPUDIATION BEFORE TIME FOR PERFORMANCE.

The refusal of one party to an executory contract, containing interdependent obligations to be performed by each party at different times, to recognize or be bound by such contract, authorizes the other party to treat it as terminated, and to bring suit for its breach at once, although the time for performance of some of the conditions by defendant has not arrived.

3. AMENDMENT OF COMPLAINT—ACTION FOR BREACH OF CONTRACT.

The complaint, in an action for breach of a contract, by the failure of defendant to pay an installment due thereunder, there being other obligations not matured, may be amended to ask damages for breach of the entire contract, where the amendment shows the contract to have been executory, and alleges that prior to the suit defendant had repudiated the same and refused to be bound thereby.

At Law. On motion for leave to amend complaint.

J. P. K. Bryan, for plaintiffs.

Mordecai & Gadsden, for defendant.

SIMONTON, Circuit Judge. This case comes up on a motion to amend the complaint, answer having been filed and served. The original complaint, after setting out the jurisdictional fact, proceeds as follows:

That on the 26th day of September, 1901, the above-named defendant made and entered into a contract with plaintiffs, a copy of which is hereto attached and made a part of this complaint, whereby defendant above named promised and agreed, in the event of the purchase or reorganization by defendant of the Charleston Waterworks, a corporation created by and existing under the laws of the state of South Carolina (referred to in contract attached as Charleston Waterworks Company), as a result of recent and pending investigations by defendant and of certain negotiations, to pay to plaintiffs the sum of ten thousand dollars (\$10,000) in cash, and to deliver to them fifty-five thousand dollars (\$55,000), par value, of stock in a proposed new company, or in the Charleston Waterworks reorganized, and promised and agreed to pay over the said \$10,000 in cash to plaintiffs at the time defendant should pay for the securities or property of the Charleston Waterworks, and to deliver to plaintiff said \$55,000 of stock of the new or reorganized company as soon as the same was issued, said sum of money and said amount of stock to be full compensation to plaintiffs for services heretofore rendered and to be rendered by them. That as a result of said investigations and negotiations the defendant above named has purchased Charleston Waterworks, and paid for the securities and property of same. That plaintiffs have in all respects and at all times performed all services they were called upon to render by said defendant, and have completely executed the contract on their part. That plaintiffs have demanded payment from defendant of the sum of \$10,000, but same has been refused.

The prayer for judgment is for \$10,000, with interest from day of June, 1902, the date on which defendant paid for the securities of said Charleston Waterworks, and the costs of the action.

The proposed amendment follows the original complaint in totidem verbis, and proposes to add the following:

"That plaintiffs have demanded from defendant the delivery of fifty-five thousand (\$55,000) dollars of stock of the Charleston Light & Water Company, the new company, which was acquired and its capitalization reorganized for the purpose of taking over the Charleston Waterworks, and the delivery of said fifty-five thousand (\$55,000) dollars of stock in the Charleston Light & Water Company has been refused by defendant. That the value of the said fifty-five thousand (\$55,000) dollars par of said stock of the Charleston Light & Water Company is fifty-five thousand (\$55,000) dollars. And said defendant has furthermore informed these plaintiffs that it repudiated any obligation to these plaintiffs, and announces its intention not to recognize in any way any liability under said contract."

The prayer for judgment is \$65,000, with interest from the ——— day of June, 1902, the date on which defendant paid for the securities of the said Charleston Waterworks.

It was stated at the bar, and the fact seems admitted, that at the time of the service of the original summons and complaint the stock provided for in the contract, made part of the complaint, had not been issued, nor had the corporation then been created.

If, then, we treat the original complaint as an action for a breach of the contract in not paying the \$10,000, the amended complaint

sets up another breach of the contract, in not furnishing the \$55,000 of stock, a breach occurring after action brought. There is no question that, both under the statutes of the United States and under the practice in South Carolina, there exists the right of liberal amendment. But "amendments to a pleading can only state facts in existence at the time when the original pleading was made. A plaintiff cannot, therefore, introduce by an amendment to his complaint facts occurring subsequent to the commencement of the action." 2 Wait, Prac. 504, cited and approved in *McCaslan v. Latimer*, 17 S. C. 128. And the conclusion is sustained by the provisions of the Code of Procedure of South Carolina. Sections 190-197, inclusive, provide for amendments of pleadings in the most liberal way. Then comes section 198, as follows:

"The plaintiff and defendant respectively, may be allowed on motion to make a supplemental complaint, answer or reply, alleging facts material to the case occurring after the former complaint, answer or reply, or of which the party was ignorant when his former pleading was made."

If, therefore, we treat this amendment simply as introducing another breach of the contract, and seeking relief also for that, it could not be permitted, as this fact occurred after suit brought. But it is contended that the tenth paragraph of the proposed amendment gives an entirely different aspect to the amendment. It alleges that the defendant has repudiated any obligation to the plaintiffs, and has announced its intention not to recognize in any way any liability under said contract and has so informed plaintiffs. For the purposes of this motion, the allegations of the proposed amendment alone are examined, not as if they were true, but as if, supposing them capable of proof, they would sustain an action.

The contract which has given rise to this suit is an executory contract. It provides for the payment in cash of \$10,000, and for the delivery at some time in the future of certain shares of stock in a corporation, not yet formed. The learned counsel for the plaintiffs insists that this case comes within the law with regard to executory contracts, the performance of which is to be at separate times, in the nature of installments. That is to say, when one party renounces it without cause before the time of performing it has elapsed he authorizes the other party to treat it as terminated, without prejudice to his action for damages,—and, if the latter elects to treat the contract as terminated, his right of action accrues at once. *Marks v. Van Ecghen* (2d Circuit) 30 C. C. A. 208, 85 Fed. 853. The rule thus laid down in this case was subsequently established by the supreme court in *Roehm v. Horst*, 178 U. S. 1, 20 Sup. Ct. 780, 44 L. Ed. 953. There the matter is elaborately discussed, and all the cases in England and in this country are quoted and reviewed. The leading case is *Hochster v. De La Tour*, 2 El. & Bl. 678. All the cases, however, in which this doctrine is followed or approved, are cases of interdependent obligations. One party agrees that he will render some work or labor in the leading case, serve as courier on certain terms for three months, or agrees to marry at a certain time (*Frost v. Knight*, L. R. 7 Exch. 111), or to receive certain goods on his ship (*Harbour Co. v. Xenos*, 11 C. B. [N. S.] 152), and the other

party thereupon agrees to do something. In other words, these are mutual obligations. This idea is further expressed in *Roehm v. Horst*, supra, replying to the idea that if this rule were adopted it would apply to cases of commercial paper, the chief justice says:

"But we are unable to assent to that view. In the case of an ordinary money contract, such as a promissory note or a bond, the consideration has passed. There are no mutual obligations. Cases of this sort do not fall within the reason of the rule."

In the same case, an opinion of Mr. Justice Peckham (*Nichols v. Steel Co.*, 137 N. Y. 471, 33 N. E. 561) is quoted with approval, as expressing this distinction:

"It is not intended that in the bald case of a party bound to pay a promissory note, which rests in the hand of the payee, but which is not yet due, such note can be made due by any notice of the maker that he does not intend to pay it when it matures. We decide simply the case where there are material provisions and obligations interdependent. In such a case, and where one party is bound from time to time as expressed to deliver part of an aggregate and specified amount of property to another, who is to pay for each parcel delivered at a certain time and in a certain way, a refusal to be further bound by the terms of the contract or to accept further deliveries, and a refusal to give the notes already demandable for a portion of the property that has been delivered, and a refusal to give any more notes at any time which are evidently to be paid under the contract, all this constitutes a breach of the contract as a whole, and gives a present right of action against the party so refusing to recover damages, which the other may sustain by reason of such refusal."

The comment of the supreme court on this is:

"We think it obvious that, both as to renunciation after commencement of performance and renunciation before the time for performance has arrived, money contracts, pure and simple, stand on a different footing from executory contracts for the purchase and sale of goods."

The following is the contract in this case:

"Baltimore, Md., Sept. 26, 1901.

"Charles R. Spence, Esqr., 2nd V. P. Mercantile Trust & Deposit Company, Baltimore, Md.—Dear Sir: We have your favor of this date in regard to the Charleston Waterworks Company matter, but same makes reference to and is based upon an option held by you upon the securities of that company, of which we have no official knowledge. As we understand your letter, in the event of the purchase or reorganization by you of the present Charleston Waterworks Company as a result of the recent and pending investigations by you, and of the negotiations which have been had between us during the past summer, you are to pay us ten thousand dollars (\$10,000) in cash, five per cent. (5%) of the capital stock of the proposed new company or of the present company reorganized, and an additional five thousand dollars (\$5,000), par value, of said stock. The cash is to be paid us at the time you pay for the securities or property of the present Charleston Waterworks Company, and the stock certificates to be delivered to us as soon as issued. With this understanding we accept your proposition, and will thank you to return the inclosed duplicate hereof after having marked same correct.

"Yours very truly,

Claudian B. Northrop.

"R. P. Tucker.

"Correct; with the understanding that the within mentioned payment is in full compensation for all services heretofore rendered and to be rendered by you. Further, with the distinct understanding that at this date we have no actual option on the Charleston Waterworks Co., but simply strong assurances that such option will be given by the first of October.

"C. R. Spence, 2nd V. P."

This is a contract by which, for services rendered and to be rendered, there will be paid \$10,000 cash, and when the stock of a certain corporation is issued there will be delivered shares equal to 5 per cent. of the capital stock, and an additional stock of the par value of \$5,000. It is an executory contract. "An executory contract is one where it is stipulated by an agreement of minds, upon a sufficient consideration, that something is to be done by one or both parties." *Farrington v. Tennessee*, 95 U. S. 683, 24 L. Ed. 558. It also comes within the reason of the rule.

This being the case, the amendment may be allowed. It is germane to the original, it grows out of the same contract, is for breach of the contract, sues for damages for the breach, and only enlarges the scope of the complaint. Having been notified, as it alleges, that the defendant does not consider itself bound by the contract, the plaintiffs could exercise the option either to wait until there was failure to deliver the stock, or to abandon the contract and sue at once for the recovery as damages the profits they would have received through full performance. *Mining Co. v. Humble*, 153 U. S. 540, 14 Sup. Ct. 876, 38 L. Ed. 814; *Pierce v. Railroad Co.*, 173 U. S. 1, 19 Sup. Ct. 335, 43 L. Ed. 591. And this right of action began before suit was brought. *Prima facie* the amended complaint set up a cause of action. The original complaint demanded \$10,000 as damages. The amended complaint asks for \$65,000. This can be allowed. *Whalen v. Gordon*, 37 C. C. A. 70, 95 Fed. 305.

In *Chamberlain v. Mensing* (C. C.) 51 Fed. 512, on a similar motion this court said:

"With regard to the proposed amendment in the prayer, it will be noted that the complaint itself contains no allegation of damages. It charges a violation of the right of plaintiff. The damages are the necessary result of such violation. So they are properly in the prayer for relief, which is no part of the complaint. *Levi v. Legg*, 23 S. C. 283. The damages are not the cause of action. The cause of action is the wrong done to the plaintiffs. The right to recover damages grows out of this wrong done, because of the wrong. The amount so recoverable depends upon the nature, character, extent, and motive of the wrongdoing. Damages being thus an incident of, necessarily flowing from, and recoverable because of, the wrong if the amendment be allowed, stating the character of the wrong, heightening and coloring it, increasing it in degree, so, also, the amendment should be allowed in the prayer for relief, increasing the amount of damages."

The motion to amend is granted.

FILHIOL et al. v. TORNEY.

(Circuit Court, E. D. Arkansas, W. D. January 12, 1903.)

No. 5,224.

1. FEDERAL COURTS—JURISDICTION—FEDERAL QUESTION—PLEADING.

An allegation in a complaint in ejectment that defendant is in possession of the property by direction of the United States, which is not required under the statute to state plaintiff's cause of action, is mere surplusage, and cannot give a federal court jurisdiction on the ground that the action is one arising under the constitution of the United States, by making it appear that defendant holds under a law which plaintiff claims to be unconstitutional.

Action in Ejectment. On demurrer for want of jurisdiction.

This is the third action in ejectment brought by the plaintiff in this cause to recover the premises in Hot Springs, Ark., known as the "Government Reservation," including the hot springs and the Army and Navy Hospital of the United States. The demurrers to the complaints in both of the former actions were sustained by the court. In the first case (*Muse v. Hotel Co.* [C. C.] 68 Fed. 637) the demurrer was to the merits of the case; but when removed to the supreme court by writ of error the cause was there dismissed for want of jurisdiction of that court, because there was no federal question involved (*Muse v. Hotel Co.*, 168 U. S. 430, 18 Sup. Ct. 109, 42 L. Ed. 531). The second action was by the supreme court reversed, with directions to this court to dismiss it for want of jurisdiction (*Filhiol v. Maurice*, 185 U. S. 108, 22 Sup. Ct. 560, 46 L. Ed. 827); and thereupon this action was instituted. The complaint does not allege that there is a diversity of citizenship between plaintiffs and defendant, but relies for jurisdiction on the facts that the plaintiffs' rights arise under the treaty with France for the purchase of the Louisiana Territory, and under the fifth amendment to the constitution of the United States. The property involved in this action includes the Army and Navy Hospital of the United States, of which the defendant is in charge, under direction of the government. The defendant demurs to the jurisdiction of this court.

Dan W. Jones and W. S. McCain, for plaintiffs.
William G. Whipple, U. S. Atty., for defendant.

TRIEBER, District Judge (after stating the facts). The allegations in the complaint as to the rights of plaintiffs under the treaty with France are practically the same as were those in the former cases, and which the supreme court held were insufficient to confer jurisdiction on a national court, and in the last case directed a dismissal of the cause for want of jurisdiction. *Filhiol v. Maurice*, 185 U. S. 108, 22 Sup. Ct. 560, 46 L. Ed. 827. There can therefore be no jurisdiction on that ground.

Does the complaint show that the cause arose under the fifth amendment to the constitution, prohibiting the exercise of federal power to deprive any person of property without due process of law or to take private property for public use without just compensation? The complaint is an ordinary action of ejectment for the recovery of

¶ 1. Jurisdiction in cases involving federal questions, see note to *Balley v. Mosher*, 11 C. C. A. 308; *Montana Ore-Purchasing Co. v. Boston & M. O. C. & S. Min. Co.*, 35 C. C. A. 7.

See Courts, vol. 13, Cent. Dig. § 841.

real estate in the state of Arkansas. The statutes of that state (Sand. & H. Dig.) regulating proceedings in ejectment are as follows:

"Sec. 2578. In all actions for the recovery of lands, except in actions of forcible entry and unlawful detainer, the plaintiff shall set forth in his complaint all deeds and other written evidences of title on which he relies for the maintenance of his suit, and shall file copies of the same as far as they can be obtained, as exhibits therewith, and shall state such facts as shall show a prima facie title in himself to the land in controversy, and the defendant in his answer shall plead in the same manner as above required from the plaintiff.

"Sec. 2579. The defendant in his answer shall set forth exceptions to any of said documentary evidence relied on by the plaintiff to which he may wish to object, which exceptions shall specifically note the objections taken, and the plaintiff shall in like manner, within three days after the filing of the answer, unless longer time is given by the court, file like exceptions to any documentary evidence exhibited by the defendant, and all such exceptions shall be passed on by the court, and shall be sustained or overruled, as the law may require; and if any exception is sustained to any such evidence the same shall not be used on the trial, unless the defect for which the exception is taken shall be covered by amendment.

"Sec. 2580. All objections to such evidences not specifically pointed out in the manner provided above shall be waived.

"Sec. 2581. To entitle the plaintiff to recover, it shall be sufficient for him to show that at the time of the commencement of the action, the defendant was in possession of the premises claimed, and that the plaintiff had title thereto, or had the right to the possession thereof."

Had plaintiffs followed this statute, merely setting up their evidences of title, the complaint would not show any jurisdiction; but in order to make such a showing they add that defendant is in possession by direction of the government, thus adding to the complaint something not required by the statute, but which might have been set up as a defense by defendant's answer. Plaintiffs' rights depend solely upon the strength of their own title, the grant from the Spanish crown, and the only object in setting up defendant's right or claim of right to possession is to inject a federal question into the case by intimating that the defendant will interpose as a defense an act violative of the national constitution. The jurisdiction of a national court cannot be invoked by anticipating a defense. In *City of Fergus Falls v. Fergus Falls Water Co.*, 19 C. C. A. 212, 72 Fed. 873, this was attempted, but the court held it could not be done. Judge Caldwell, in delivering the opinion of the court, said:

"In equity pleadings the complainant is allowed to anticipate and avoid a defense, and this is called 'the charging part of the bill.' But at law the plaintiff is never expected to state matters which should come more properly from the other side. It is sufficient for each party to make out his own case. It is sufficient for the plaintiff to state his own cause of action, and he should not anticipate his adversary's defense, for the reason that the latter may never make the defense sought to be guarded against. * * * And it is equally well settled that the suggestion in a complaint in an action at law that the defendant may or will set up a defense based on a state statute repugnant to the constitution does not make the suit one arising under the constitution. The averments of the complaint, beyond those which state a cause of action, are mere surplusage. When the statement of the plaintiff's cause of action, in legal and logical form, such as is required by the rules of good pleading, does not disclose that the suit is one arising under the constitution or laws of the United States, then the suit is not one arising under that constitution or those laws, and the circuit court has no jurisdiction."

In *Tennessee v. Union & Planters' Bank*, 152 U. S. 454, 14 Sup. Ct. 654, 38 L. Ed. 511, it was sought to invoke the jurisdiction of the national courts by a suggestion in the bill "that the defendants will contend that the law of the state under which the plaintiff claims is void, because in contravention of the constitution of the United States," but it was held that:

"By the settled law of this court, as appears from the decisions above cited, a suggestion of one party that the other will or may set up a claim under the constitution or laws of the United States does not make the suit one arising under that constitution or those laws."

To the same effect see *Chappell v. Waterworth*, 155 U. S. 102, 15 Sup. Ct. 34, 39 L. Ed. 85; *Walker v. Collins*, 167 U. S. 57, 17 Sup. Ct. 738, 42 L. Ed. 76; *Sawyer v. Kochersperger*, 170 U. S. 303, 18 Sup. Ct. 946, 42 L. Ed. 1046; *Railway Co. v. Bell*, 176 U. S. 321, 20 Sup. Ct. 399, 44 L. Ed. 486; *Arkansas v. Kansas & T. Coal Co.*, 183 U. S. 185, 22 Sup. Ct. 47, 46 L. Ed. 144; *Montana Ore-Purchasing Co. v. Boston & M. Consol. Copper & Silver Min. Co.*, 35 C. C. A. 1, 5, 93 Fed. 274, 279.

Treating the allegations anticipating defendant's defense as surplusage, there is clearly no federal question involved, and the court is without jurisdiction.

In re **PARSCHEN**.

(Circuit Court, N. D. Ohio, E. D. June 18, 1902.)

1. BANKRUPTCY—RIGHTS OF WIDOW ON BANKRUPT'S DEATH.

Under Bankr. Act 1898, § 8 [U. S. Comp. St. 1901, p. 3425], providing that on the death of a bankrupt pending the bankruptcy proceedings his widow shall be entitled to the allowances fixed by the laws of the state of the bankrupt's residence, a widow of a bankrupt residing in Ohio is entitled to reside a year in the mansion house of her deceased husband, if dower is not sooner assigned, as provided by Ohio Rev. St. § 4188.

2. SAME.

The widow is also entitled to the articles enumerated in Ohio Rev. St. §§ 6038, 6039, or, in their absence, their equivalent in money, to be reserved out of the estate, and also the allowance for a year's support for herself and children fixed by the probate court appraisers, and approved by the court, as provided by section 6040.

3. SAME.

The property and allowances awarded the widow by Ohio Rev. St. §§ 6038-6040, are in lieu of the exemptions the husband would be entitled to from the bankrupt estate in case he had lived, the right to exemptions expiring with his life.

In Bankruptcy.

Smith & Taft, for widow.

R. A. Castner, for trustee.

WING, District Judge. Section 8 of the bankruptcy act of 1898 [U. S. Comp. St. 1901, p. 3425] provides that, in the event of the death of the bankrupt pending the proceedings, the widow and children shall be entitled to all right of dower and allowance fixed by the laws of the state of the bankrupt's residence. Section 4188 of the Revised Statutes of Ohio provides that the widow may remain in the mansion house

of her deceased husband for one year, if dower is not sooner assigned. That is a right which the widow in this case is entitled to enjoy, and it was so held by the referee. As against the trustee of the bankrupt, the court holds that she be yielded that right. Sections 6038, 6039, Rev. St. Ohio, provide that certain articles, or, in their absence, the equivalent in money, be reserved to the widow out of the estate; and by section 6040, Rev. St. Ohio, an allowance is made to the widow and children for their support. All of these rights of the widow are allowances, and should be recognized as distinguished from her right of dower.

By the sections referred to, the appraisers appointed by the probate court are the persons designated to make this allowance for the support of the widow. The action of the appraisers may be reviewed, but, if not changed by the court, it fixes the amount. In this case the sum of \$600 was set off and allowed to the widow by the action taken in the probate court. This amount should be paid to her by the trustee, providing that amount shall remain in his hands after payment of costs and any mortgage to which the widow was a party, out of its appropriate fund.

The widow is not entitled to the exemptions demanded by the husband. Even though the bankrupt were entitled to withhold from distribution to his creditors property or money during his lifetime, that right expired with his life. It is the intention of the statutes to give to the widow a year's allowance, and the property and money described in section 6038, in lieu of the exemptions which might have been claimed and held by the husband in his lifetime. It certainly cannot be the intention of the statutes to give to a widow, out of the estate of her husband, who has commenced proceedings in bankruptcy, more than she would have been entitled to had he not commenced such proceedings. To give to the widow both the exemptions reserved by the husband in his proceedings in bankruptcy and the allowances provided by the statutes of Ohio would bring about such a result.

An order may therefore be drawn directing—First, that the trustees permit the widow, Ida M. Parschen, to remain in the mansion house for the period of one year, unless dower is sooner assigned to her therein; second, that the trustee pay to her the allowance made to her under sections 6040, 6041, Rev. St. Ohio, to wit, the sum of \$600, provided there shall be so much in his hands after paying costs and any mortgage to which the widow was a party out of funds arising from the sale of the mortgaged premises; third, that the trustee permit her to retain such parts of the assets of said estate as are mentioned in section 6038 Rev. St. Ohio; fourth, that nothing be paid or turned over to Charles H. Stearns, executor of the estate of A. W. Parschen, on account of exemptions claimed by said Parschen in the proceedings in bankruptcy.

The decision of the referee, to the extent that it is inconsistent with the above holding, is overruled, and exceptions by the trustee noted.

HAWES et al. v. WARREN et al.

(Circuit Court, D. Maine. December 19, 1902.)

No. 118.

1. NEGLIGENCE—DAMAGE FROM FIRE.

In an action for damages from fire, caused by the alleged negligence of defendants in installing an electric motor and appliances in plaintiffs' building, it is necessary for the plaintiffs to develop some theory as to how the fire was caused, and furnish proofs to support the theory.

2. SAME—EVIDENCE—QUESTION FOR JURY.

In this case the question of defendants' negligence was properly submitted to the jury, though plaintiffs' evidence in support of their theory as to how the fire was caused was weak.

3. EVIDENCE—OPINION—GROUNDS.

In stating opinions as to the value of a building destroyed by fire, witnesses should be required to state the grounds on which their estimates are based; otherwise the reliability of the estimates cannot be determined.

4. EXCESSIVE VERDICT—DISPOSITION OF CAUSE.

Though a verdict for excessive damages is usually to be regarded as indicating partiality or inconsiderateness necessitating a reversal, the court may allow such a verdict to stand, if the excess be remitted, where it is satisfied that the jury acted honestly, and that their error as to damages arose from lack of a full presentation of that issue.

A. F. Moulton, for plaintiffs.

George E. Bird and William M. Bradley, for defendants.

PUTNAM, Circuit Judge. This case was tried to the jury at this term, and a verdict in behalf of the plaintiffs was rendered against the defendants for \$2,658.33. The declaration charges that the plaintiffs were owners of a building in Westbrook, and that the same was destroyed by fire by reason of the negligence of the defendants with reference to a certain electric motor, its wires, appliances, and connections, which the defendants had installed. The present matter for consideration is a motion of the defendants to set aside the verdict on general grounds, and also because the damages were excessive.

Mr. Quimby, referred to in the following extract from the charge to the jury, was the husband of one of the plaintiffs. Among other things, the court charged the jury as follows:

"In order that the plaintiffs may recover, they must satisfy you by a preponderance of the case: First, that the defendants were guilty of negligence; and, second, that the defendants' negligence caused the fire." "If they had no directions from Mr. Quimby as to what particular mechanism they should select, then their responsibility for the exercise of skill and good judgment begins at the beginning of the whole transaction, and relates to everything connected with it, including the condition of the starting box and the condition of the motor, whatever it was. There is no evidence—and I say this to you plainly, for I think you will so find—that Mr. Quimby was an expert in electrical appliances, and no evidence that he undertook to interfere with the defendants in what mechanism they should select, or how they should place it, or that he knew how to interfere. Therefore the case rested, so far as this particular is concerned, entirely upon the defendants to supply the req-

¶ 3. See Evidence, vol. 20, Cent. Dig. § 2303.

¶ 4. Reduction or increase of amount of recovery on appeal, see note to *The Homer*, 48 C. C. A. 470.

uisite and proper mechanism, and to place it and install it in a proper manner, with reasonable care and without negligence."

Of course, in carrying the burden of showing that the defendants were guilty of negligence, and that their negligence caused the fire, it was necessary for the plaintiffs to develop some theory as to the precise manner in which the fire was caused, involving pointing out the particular portions of the electrical plants which caused it, and furnishing proofs to support the theory. During the progress of the trial the presiding judge was very expectant that the plaintiffs would be compelled to rely on a general attack on various portions of the plant, and would fail in the particulars referred to, and that, therefore, the court might be compelled to direct a verdict for the defendants. Nevertheless, before the evidence was concluded, the plaintiffs developed a special theory of this nature, and some facts to support that theory, with reference to one of the starting boxes. There was enough of this to prevent the presiding judge from directing a verdict for the defendants, and this court still continues of the impression that such a verdict should not have been directed; and, of course, such impression continuing, even though the case in behalf of the plaintiffs were a feeble one, the verdict cannot be set aside for any reasons touching its substance. It should be added, however, that *Railroad Co. v. Richardson*, 91 U. S. 454, 23 L. Ed. 356, permits a very loose line of proof with reference to the origin of fires alleged to have been caused by defective mechanism; so that, except for the authority of that case, which bears directly on some phases of the suit now before us, the verdict would find so little support in the evidence produced as to require us to disregard it.

With reference to the matter of damages, however, we think the verdict was clearly an unsuitable one. The building was located in, or approximately to, the village of Saccarappa. It was a large wooden structure, erected for a shoe factory about 15 years before the fire. It was a failure for the purposes for which it was constructed, and for several years it had been occupied only incidentally, and the occupation at the time of its destruction by fire was not at all a profitable one. The loss was total. The only witnesses who testified as to its value in behalf of the two plaintiffs were their husbands, who were undoubtedly competent witnesses, and men of fair and honest appearance. The values at which they estimated the building were but a few hundred dollars in excess of the amount returned by the jury. The grounds on which they based their estimates were not very fully developed, either on their direct examination or cross-examination. Of course, in no event can the value of such estimates be determined without knowing exactly from what standpoint they are made. Unless thoroughly tested by examination and cross-examination, it may happen that a witness giving an estimate of that character is, unbeknown to the court and the jury, governed by his computation of the cost of reproducing the building; or it may be that he bases his estimate on what the building would be worth in the event, at some indefinite future period, it unexpectedly comes into full use. Of course, all values based too much on such considerations, or either of them, are delusive.

Moreover, notwithstanding our favorable comments on the witnesses, they were the husbands, respectively, of the two plaintiffs, so that their unsupported opinions could hardly be accepted in a court of justice. On the whole, the various matters to which we have called attention with reference to the value of this building could not have been properly weighed by the jury; and the jury naturally would not have the experience which the court has to enable them to weigh properly the various features, and estimate properly the class of testimony, to which we have referred, unless they had been especially cautioned by the court so to do, and the proofs had been elaborately commented on. There was no such elaboration; so that the result reached may well be assumed to have been one of misapprehension, without involving any reflection on the general capacity of the members of the jury as jurors, or their disposition to do justice.

It frequently occurs that judicial tribunals to which applications are made for the purpose of setting aside verdicts of juries are left in the position in which we are left; that is to say, they find sufficient evidence in the case to warrant the verdict on the main issue, but conclude that the damages are excessive. Under such circumstances the courts commonly allow the verdicts to stand if a proper portion of the damages is remitted, but, generally, this is not the true rule of procedure. Ordinarily, when a jury returns excessive damages, the conclusion resulting from that fact alone should be that the jury was governed by partiality, or has been inconsiderate; so that, therefore, the parties have not had for the determination of their rights the tribunal which the law of the land entitles them to. Partiality or inconsiderateness with reference to the damages awarded ordinarily taints the entire verdict, so that the whole should be disregarded. But in the case at bar, for the reasons we have stated, and for other reasons which we need not state, we are entirely satisfied that the jury proceeded honestly and considerately as to all matters to which their attention was carefully called. Therefore we feel ourselves justified in allowing the verdict to stand, provided the damages are remitted as we shall direct. Nevertheless, the whole case is in such extreme doubt that, if damages are not remitted, we feel that justice would be more likely to be promoted by giving parties a new trial of the whole case.

Ordered, unless the plaintiffs remit on or before the 31st day of January, 1903, all damages awarded by the verdict of the jury in excess of \$1,400, the verdict will be set aside, and a new trial granted.

CAMPBELL et al. v. MILLIKEN et al.

(Circuit Court, D. Colorado. November 29, 1902.)

No. 370.

1. REMOVAL OF CAUSES—SEPARABLE CONTROVERSY—SUIT BY STOCKHOLDERS.

In a suit against a corporation and certain of its officers, brought by stockholders on an allegation that the corporation is under the control of such officers, the purpose of which is to require the individual defendants to account to the corporation for funds alleged to have been appropriated by them to their own use, and to prevent the holding of a meeting, called by them, for the purpose of having the property of the company conveyed to another corporation, there is no controversy between the complainants and the company which entitles the latter to remove the cause from a state court on the ground that it is a non-resident and that there is a separable controversy, although incidental relief by way of an injunction and the appointment of a receiver may be prayed for against it, such relief not being asked adversely to the corporation, but in its interest, and the only real controversy being between complainants and the individual defendants.

On Application to File Transcript on Removal after Denial of Application by State Court.

Charles T. Potter, for complainants.

Tyson S. Dines and John M. Waldron, for respondents.

HALLETT, District Judge (orally). In this case application was made on yesterday to file a transcript of the record upon removal of the cause from the district court of Teller county. I have reached the conclusion that the application must be denied. The bill is by stockholders to enforce demands against two of the officers of the Golden Cycle Mining Company. Various charges are made of misconduct on the part of the natural persons, defendants in the bill, Milliken and Hill, that they have taken funds of the corporation, and applied them to their own use. The purpose of the bill is to have these defendants account to the corporation for moneys so taken. In addition to this, it is charged that these natural persons have called a meeting of the corporation to be held on Monday next, and the purpose is at that meeting to cause the property of the company to be conveyed to a new company organized in the territory of Arizona. And for the purpose of preventing the accomplishment of any such purpose as that, and the further diversion of funds of the corporation to their own use, the bill asks that they may be enjoined from holding the meeting, and from conveying the property, and also asks that a receiver may be appointed. This relief is asked as to the Golden Cycle Mining Company as well as to the individual defendants. What is asked in respect to the Golden Cycle Mining Company is not in the way of ultimate relief. There is no final decree sought in respect to that company as a measure of general relief, and there could not be in a suit of this kind, unless it were a dissolution of the corporation; and that is not sought. This is a suit, in effect, by the corporation against its officers. Be-

¶ 1. Separable controversy, see notes to *Robbins v. Ellenbogen*, 18 C. C. A. 86; *Mecke v. Mineral Co.*, 35 C. C. A. 155.

cause the corporation is under the control of the officers, as alleged, the suit is brought by stockholders in behalf of the corporation. So that, as to the relief sought the suit is not adverse to the Golden Cycle Mining Company, and there is no issue, except in a mere formal and technical sense, between the Golden Cycle Mining Company and the complainants in the suit. The issue is between complainant and the officers, Hill and Milliken, and the relief is sought against them. So that, instead of there being a separate controversy between the complainants and the Golden Cycle Mining Company, there is in fact no controversy whatever in any respect between that company and the complainants. The controversy is between Hill and Milliken, officers of the Golden Cycle Mining Company, and the complainants. It was said in argument that this might be true if Hill and Milliken were sued only as individuals, and not as officers of the company. But I do not suppose that a court, when it comes to administer final relief in an action of this kind, will consider whether the natural persons are in court as officers or as individuals, one or both. However they may be in court, if they are there in their own proper persons, the court may give such relief as the facts of the case demand.

It seems to me that the petition for removal was rightly denied in the district court, and it will be denied here.

CAMPBELL et al. v. MILLIKEN et al.

(Circuit Court, D. Colorado. December 18, 1902.)

No. 4,376.

1. REMOVAL OF CAUSES—LOCAL PREJUDICE—CITIZENSHIP OF PARTIES.

One of two defendants, both necessary parties to the suit, and where there is no separable controversy, cannot remove the cause on the ground of prejudice or local influence, under the fourth subdivision of section 2 of the judiciary act of 1887-1888 [U. S. Comp. St. 1901, p. 509], where his codefendant is a citizen of the same state as the plaintiffs.

On Application for Removal on the Ground of Local Prejudice.

Charles T. Potter and Karl C. Schuyler, for complainants.

John M. Waldron and Tyson S. Dines, for respondents and for petitioners for removal.

RINER, District Judge. This is an application to remove this case from the district court sitting within and for Teller county, in the state of Colorado, upon the ground of local prejudice under the fourth paragraph of the second section of the act of August 13, 1888 [U. S. Comp. St. 1901, p. 509], providing for the removal of causes from the state court to the circuit court of the United States. The application is made on behalf of the Golden Cycle Mining Company and John T. Milliken, its president, both nonresidents of the state of Colorado. The plaintiffs, and also the defendant L. E. Hill, are citizens of the

¶ 1. Prejudice or local influence as ground for removal of cause to federal court, see note to *Schwenk v. Strang*, 8 C. C. A. 95.

state of Colorado. The bill in the case sought to be removed prays that the defendants Milliken and Hill be compelled to account to the Golden Cycle Mining Company for all moneys taken and received by them or either of them to any person or persons from the assets and funds of said corporation, and that they be restrained from in any way or manner using the works, drifts, shafts, machinery, buildings, or other property of the Golden Cycle Mining Company in operating a certain lease which it is alleged they hold upon the Theresa lode mining claim; that, if it appears and is determined upon the hearing of the case that the above-named defendants have unlawfully or without authority deeded or conveyed to any person or persons or corporations any part of the property of the Golden Cycle Mining Company, they be compelled to account to the company therefor, and to pay the company the damages sustained by reason thereof; and that they be enjoined from holding a certain stockholders' meeting called for the hour of 2 o'clock in the afternoon of December 1st; and that they be restrained and enjoined from transferring, deeding, conveying, assigning, or in any manner disposing of any of the assets or property of the defendant the Golden Cycle Mining Company to an Arizona corporation, or any other corporation, or any other person or persons. An examination of the bill discloses the fact that the real controversy in the case is between the complainants and the defendants Milliken and Hill. Upon the facts as disclosed in the affidavits, the court is of opinion that defendants have made a sufficient showing of fact to entitle them to remove the cause, provided it is a case removable under the fourth subdivision of the second section of the statute above referred to. It is urged, however, in opposition to the petition for removal, that the case is not one of which the circuit court of the United States can take jurisdiction, by reason of the fact that one of the defendants, L. E. Hill (whom it clearly appears is a necessary party), is a resident of the state of Colorado, the same state of which the complainants are residents, and therefore this suit is not a controversy between citizens of the state in which the suit is brought, and a citizen of another state.

This is the second appearance of this case before the court at this term. 119 Fed. 981. It was first sought to remove the cause from the state court to this court upon the ground of the diverse citizenship of the defendant the Golden Cycle Mining Company, that company being a citizen of the state of West Virginia, and the plaintiffs, they all being citizens of the state of Colorado, and upon the additional ground that a separable controversy existed in said suit as between the defendant the Golden Cycle Mining Company and the complainants and as between the plaintiffs and the remaining defendants. This application was denied by this court, and the question, therefore, of a separable controversy existing in the suit is not before the court in any way; that question having been settled, so far as this case is concerned, by Judge Hallett, on the first application to remove. The question, and the only question other than the question of fact as to whether prejudice or local influence exists on account of which the removal is sought, is whether or not one of two defendants, both necessary parties to the suit, can remove a case where his codefendant is a citi-

zen of the same state with the plaintiffs in the suit. Upon this question the decisions of the circuit courts of the different circuits are in conflict, and, unfortunately, the question has never been passed upon by the supreme court. It was urged at the argument that Judge Caldwell, in the case of *Bartlett v. Gates* (decided in this court) 118 Fed. 66, passed upon the question now presented to the court for determination. I regret very much to find that such is not the case. Had he done so, it would have relieved the court in this case from the necessity of spending several hours' labor in the examination of authorities cited by counsel at the argument. The case of *Bartlett v. Gates* was a suit brought by Bartlett for himself and on behalf of all stockholders similarly situated against a number of citizens of the same state with the plaintiff, and the five defendants, citizens of another state, who filed the petition for removal. The rule is well settled that when a controversy about which a suit is brought in the state court is between citizens of one or more states on one side, and citizens of other states on the other side, any defendant, party to the controversy, may remove the suit to the circuit court of the United States, without regard to the position he occupies in the pleadings, as plaintiff or defendant; and for the purposes of removal the matter in dispute may be ascertained by the court, and the parties to the suit arranged on opposite sides of that dispute. If in such arrangement it appears that those on one side are all citizens of different states from those on the other, the suit may be removed. The mere form of pleading may be put aside, and the parties placed on different sides of the matter in dispute according to the facts. Judge Caldwell found the facts in *Bartlett v. Gates* within this rule, the substance of which I have just stated. In the course of his opinion, at page 69, 118 Fed., he used this language:

"Plainly, there are but two parties to this controversy,—one, the directors and stockholders, wishing to retain the present management; and the other, the stockholders who wished to displace the present management; and all persons on the one side make common cause against all those on the other. The original bill was filed in the name of 'George F. Bartlett, for and on behalf of any and all stockholders of the defendant corporation who are similarly situated, and who may wish to join in this action,' and it is quite obvious that the principal defendants in the cross-bill gladly availed themselves of the benefit of the injunction. They took no steps to have it dissolved or modified, and are at one with the plaintiff named in the bill, and may be properly included among those 'similarly situated' with the plaintiff, for whose benefit the bill was brought. It will be observed that the chief ground upon which the injunction was asked and obtained was that the directors and officers of the company had neglected and refused to perform their legal duties as such officers, duties imposed upon them by the law of the state and the by-laws of the company, and which they intentionally and willfully refused to perform for the very purpose of preventing the holding of the annual stockholders' meeting for the election of directors. They could not well be named as plaintiffs in a bill seeking an injunction on the ground of their own dereliction of their official duties, and hence they were made defendants to the bill; but they eagerly accepted the benefits of the injunction which effected the purpose they had been struggling to accomplish, and for which their own illegal action had laid the foundation. The injunction accomplished the very object they desired, and, though named as defendants, they are in reality plaintiffs, and must be so treated."

I think it cannot be said, therefore, that Judge Caldwell passed upon the question now before the court, and which was before the court in

Anderson v. Bowers (decided by Judge Shiras, of this circuit, in 1890) 43 Fed. 321, and indirectly, if not directly, overruled the conclusions reached by the court in that case. As I said a moment ago, the court regrets that Judge Caldwell did not have occasion to pass directly upon this question, as this court would certainly have followed a decision made by that eminent jurist, and thereby relieved itself of the labor incident to the thorough examination which the court has found it necessary to make of the adjudications in the various circuits.

After the argument was concluded, my attention was called to a lecture delivered before the St. Louis Law School by the Honorable Amos M. Thayer, circuit judge of this circuit, upon the subject of removal of causes, in which he uses the following language:

"And in such cases a cause is removable at the instance of a nonresident defendant or defendants, though certain residents of the state in which the suit is pending have been joined as codefendants with nonresident defendant or defendants."

And cites in support of the proposition the cases of *Whelan v. Railroad Co.* (C. C.) 35 Fed. 849, 1 L. R. A. 65; *Thouron v. Railroad Co.* (C. C.) 38 Fed. 673; *Niblock v. Alexander* (C. C.) 44 Fed. 306. This, I think, is undoubtedly a correct statement of the rule in a case where there is a separable controversy. The case of *Niblock v. Alexander* (C. C.) 44 Fed. 306, is a case in which the plaintiffs were citizens of different states, and hence the removal was denied. In the case of *Thouron v. Railroad Co.* (C. C.) 38 Fed. 673, the opinion of the court was delivered by Judge Jackson, the same judge who delivered the opinion of the court in the case of *Whelan v. Railroad Co.* (C. C.) 35 Fed. 849, 1 L. R. A. 65. While the learned judge in the latter case distinguished that case from *Whelan v. Railroad Co.*, and sustained a motion to remand, he has this to say of the construction to be given to the statute:

"In so far, therefore, as the act of March 3, 1887 (re-enacted in 1888), copies old clauses and provisions of the act of 1867 [U. S. Comp. St. 1901, p. 509], it must be regarded as a legislative re-enactment of the meaning which the supreme court had previously given to those clauses."

The act of 1867 provided that, where a suit is now pending or may hereafter be brought in any state court in which there is a controversy between a citizen of the state in which the suit is brought and a citizen of another state, etc., the citizen of such other state, whether plaintiff or defendant, making the required affidavit, and within the time prescribed, was allowed to remove the suit. This clause defines the class of controversies which are removable under its provisions, and also declares by whom the right of removal may be exercised. In cases wherein there was more than one plaintiff or defendant, the supreme court held, under this act, that all interested on one side of the controversy must be citizens of the state in which the suit was brought, and all interested adversely must be citizens of other states; and, further, that all the citizens of the state or states other than that in which the suit was pending must unite in the application for removal. *Sewing Mach. Cos. Case*, 18 Wall. 553, 21 L. Ed. 914. This same construction was applied to the local prejudice clause under this act. *Society v. Price*, 110 U. S. 61, 3 Sup. Ct. 440, 28 L. Ed. 70; *Hancock*

v. Holbrook, 119 U. S. 586, 7 Sup. Ct. 341, 30 L. Ed. 538. It will be noticed that the class of cases to which the local prejudice clause was applicable under the act of 1867 was that class wherein one side of the controversy was represented by a citizen or citizens of the state wherein the suit was pending, and the other by a citizen or citizens of other states, and did not include cases wherein the controversy was partly between citizens of the same state. In respect to the character of the suit and the parties thereto, the language of the act of 1867 and the act of 1888 is identical. The act of 1867 provided that:

"Where a suit is now pending or may hereafter be brought in any state court, in which there is a controversy between a citizen of the state in which the suit is brought, and a citizen of another state," etc., "the citizen of such other state, whether plaintiff or defendant, making required affidavit within the time prescribed, is allowed to remove the suit."

The first portion of the fourth subdivision of section 2 of the act of 1888 [U. S. Comp. St. 1901, p. 509] employs the same descriptive terms as to suits and parties, but limits the right of removal to any defendant being a citizen of another state. The suit described in both acts as to parties is "between a citizen of the state in which it is brought and a citizen of another state."

While the supreme court of the United States has never passed upon the question now before the court, Mr. Justice Bradley, delivering the opinion of the court in *Ex parte Pennsylvania Co.*, 137 U. S. 451, 11 Sup. Ct. 141, 34 L. Ed. 738, having under consideration the fourth clause of this section, said:

"The initial words 'And where' are equivalent to the phrase 'And when in any such case.' In effect they are tantamount to the beginning words of the third clause, namely, 'And where in any suit mentioned in this section.'"

Judge Shiras, in *Anderson v. Bowers*, in considering this identical question, uses this language:

"When congress enacted the statute of 1888, and used therein the same definition of the class of cases removable on the grounds of local influence or prejudice, is there any escaping from the conclusion that the same construction should be applied thereto? It is well settled that, where the terms used in the statute have acquired a well-understood meaning through judicial interpretation, and the same terms are used in a subsequent statute upon the same subject, the presumption is that it was the legislative intent that the same interpretation should be given thereto, unless by qualifying or explanatory additions the contrary intent is made to appear. * * * It is urged in argument that the use of the words 'any defendant,' being such citizen of another state, may remove, etc., implies that there may be defendants who are not citizens of another state, and yet the case may be removed if there is a defendant who is a citizen of another state. It cannot be gainsaid that the words are susceptible of this construction, and, if the class of cases removable under this clause had not been previously defined and limited, it might well be that such construction would be permissible. In view, however, of the settled construction given to the preceding portion of the clause, I do not think this possible implication should be held to show that it was intended to change the meaning of the terms previously used. It seems to me to be the true rule to give the words, 'in which there is a controversy between a citizen of the state in which the suit is brought and a citizen of another state,' the same meaning in the act of 1888 as was given then in construing the act of 1867; thus holding that the class of cases removable on the ground of prejudice and local influence is confined to those in which there is a controversy between a citizen or citizens of the state in which the suit is pending and a citizen or citizens of another or other states,

but not including suits in which there is a controversy partly between a citizen or citizens of the state wherein the suit is pending and a citizen or citizens of other states, and partly between citizens of the same state."

While the views expressed by Judge Shiras differ from the views expressed by the circuit court in other circuits, I am inclined to concur in the reasoning of that case, and hold that the application for removal must be denied.

In re HOYT et al.

(District Court, E. D. North Carolina. January 8, 1903.)

1. BANKRUPTCY—PAYING OUT FUNDS BY TRUSTEE—FAILURE TO COMPLY WITH RULES.

A payment to a bankrupt by his trustee of a sum claimed as an exemption, from the funds of the estate, will not be allowed on settlement of the estate, where it does not appear that the exemption was set aside by the trustee as required by the bankruptcy act, or that the money was placed in the depository designated by the court, and paid out in the manner prescribed by the rules in bankruptcy.

2. SAME—COSTS—PAYMENTS FOR BONDS.

Amounts paid sureties on a bond cannot be taxed as costs. Giving such bonds in a surety company is a privilege and convenience, but the fee paid therefor is not taxable as costs under any rule of court.

In Bankruptcy. On report of special master.

F. H. Bersten, for confirmation.

B. F. McLean, opposed.

PURNELL, District Judge. This proceeding in bankruptcy having on motion been referred, upon the coming in of the report of the special master herein appointed it is considered and ordered that the same be, and is, in all respects affirmed, except as hereinafter noted.

The payment of \$500 each to the bankrupts by the trustee as a personal property exemption is disallowed. It appears this was done in violation of general order of the supreme court No. 29, and bankrupt rule of this district No. 10. There is no evidence this fund was deposited in a designated depository, and was paid to the bankrupts after it appeared by numerous affidavits they had sold the stock of goods and disclaimed any interest therein, which appears to be the only source from which the fund constituting the assets of the estate was derived. The constitution of North Carolina, under which debtors are allowed a personal property exemption, is article 10, § 1:

"The personal property of any resident of this state, to the value of five hundred dollars, to be selected by such resident, shall be, and is hereby exempted from sale under execution, or other final process of any court, issued for the collection of any debt."

Under Bankr. Act, § 47, subd. 11 [U. S. Comp. St. 1901, p. 3438], it is made the duty of the trustee to set aside the exemptions of the bankrupt "and report the same to the court." There is no evidence in the record this was done. There were, long before this amount was paid, proceedings in both the United States and state courts at the place where the bankrupts, the trustee, and the party who claims the goods reside, which were legal, if not actual, notice that another

claimed the goods; and it appears in the record that the law firm of which the trustee is a member represented petitioning creditors, and hence there was actual notice of such claim. Amounts paid out by trustees otherwise than is allowed in the bankrupt act will not be allowed in the settlement of the estate. The manifest purpose of congress in requiring trustees, referees, and designated depositories to give bonds was to protect estates in bankruptcy from (among other acts on the part of these officers of the court) paying out funds otherwise than the law and rules permit. For this amount (\$1,000) the trustee is primarily liable on his bond; and, if the amount was paid by or under the authority of the referee, this officer would be liable secondarily on his official bond, as would the designated depository if the fund had been deposited therein and paid out otherwise than is provided in the rules above cited, which rules have been duly certified as required. To deposit the funds of a bankrupt estate in any bank other than a designated depository renders the officers making such deposit liable.

The claim of the O. K. Stove & Range Company, amounting to \$607.27, mostly for attorneys' fees and expenses, except as allowed by the special master, is disallowed. Two items in this claim are for bonds,—one it does not appear for what it was given; and the other states, bond to indemnify the marshal. The costs in bankruptcy go, as in other causes, to the prevailing party. These parties have not prevailed, and are not entitled to costs. They are entitled to have the filing fees refunded, under the act (section 2, subd. 18 [U. S. Comp. St. 1901, p. 3421]). It is presumed the bonds were given in a surety company, but this does not appear, and no voucher is filed showing the amount.

Prior to the act of congress giving the privilege of giving bonds in surety companies (a modern convenience), such a thing as a fee for bondsmen was unheard of as costs. There is no act making it taxable as costs, and, while courts may have allowed such costs to prevailing parties litigant, it is a new departure, and has not yet become the rule of court. But this is upon a supposition or presumption. It does not appear the amounts were paid a surety company, and they must be disallowed for the reasons stated in the report of the special master.

After paying the amounts set out in the report of the special master, including the bill of costs in this proceeding in the United States court, and the fees of the trustee as fixed in the bankrupt act, the balance in the depository will be at once reported to this court. And this proceeding in bankruptcy is held for further order.

WHITE et al. v. BRADLEY TIMBER CO.

(District Court, S. D. Alabama. November 26, 1902.)

No. 148.

1. ACT OF BANKRUPTCY—FAILURE TO DISCHARGE LIEN—INTENT.

Under Bankr. Act, § 3, cl. 3 [U. S. Comp. St. 1901, p. 3422], providing that acts of bankruptcy by a person shall consist of his having "(3) suffered or permitted, while insolvent, any creditor to obtain a preference through legal proceedings," the intent of the insolvent is immaterial; and when an insolvent corporation fails to cause a preference by legal proceedings obtained by one creditor to be vacated or discharged by showing that the claim is illegal or unfounded, or by paying the debt, such insolvent commits an act of bankruptcy.

In Bankruptcy.

Fitts & Stoutz, for complainants.

Fred G. & C. L. Bromberg, for defendant.

TOULMIN, District Judge. A jury trial was demanded by the alleged bankrupt, which, under the charge of the court, resulted in a verdict finding that the company had committed an act of bankruptcy under clause 3 of section 3 of the bankrupt act [U. S. Comp. St. 1901, p. 3422], being the provision relating to preferences under legal proceedings. A motion was made by the defendant company to set aside the verdict on the ground that the court erred in giving the charge requested by the petitioners and in refusing the charges requested by the defendant. After due consideration of the motion and the argument submitted in its support the motion is denied.

A careful examination of the authorities satisfies me that the conclusion reached by me is sustained by a decided weight of authority. I cite, as sustaining that conclusion, the following: In re Reichman (D. C.) 91 Fed. 624; In re Moyer (D. C.) 93 Fed. 188; In re Ferguson (D. C.) 95 Fed. 429; In re Rome Planing Mill (D. C.) 96 Fed. 812; Manufacturing Co. v. Stoever (1st Cir.) 38 C. C. A. 200, 97 Fed. 330; Wilson v. Nelson, 183 U. S. 191, 22 Sup. Ct. 74, 46 L. Ed. 147.

The principal end of the bankrupt law is to take into legal custody all the property and assets of a man who is unable to pay his debts for the purpose of making a fair and just distribution of them among his creditors. The theory is that when a man is unable to pay his just debts the property remaining to him rightly belongs to his creditors, and ought to be distributed ratably among them towards the satisfaction of their debts. In order to secure this purpose of the bankrupt law—that is, the ratable distribution of the property of an insolvent debtor among his creditors—no one creditor should be suffered or permitted to obtain a preference over the other creditors. If he is "suffered or permitted" to do so by the debtor's failure to vacate or discharge the preference, either by showing that the claim was illegal or unfounded or by paying the debt, the result is to leave the debtor as having committed an act of bankruptcy. The fact of such failure

¶ 1. See Bankruptcy, vol. 6, Cent. Dig. § 82.

is, in contemplation of clause 3, § 3, of the bankrupt law, an act of bankruptcy.

It will be observed that the clause of the bankrupt law referred to says nothing about the bankrupt's intent to enable the creditor to secure a preference; neither does it use the word "procure," which might seem to imply that the debtor must take some part in bringing the preference about, as was the case under the bankrupt act of 1867. The actual results only are considered by the present act. The actual result attained by the creditor seems to be the dominant fact. The debtor's intent regarding the matter is wholly immaterial. In *Re Rome Planing Mill*, supra, the court said: "The debtor's intent is not made an ingredient. It is enough that the creditor has obtained a preference, and that the debtor has permitted it to remain undischarged. What was the debtor's intent regarding the matter is wholly immaterial."

In *Manufacturing Co. v. Stoeber*, supra, the circuit court of appeals, in considering the proposition submitted by the appellant (the alleged bankrupt corporation), that the words "suffered or permitted" found in the statute must have a narrow, literal interpretation, said:

"In giving the words a narrow interpretation, the appellant refers only to the following portion of the statute cited, namely, 'suffered or permitted,' while insolvent, any creditor to obtain a preference through legal proceedings. It maintains that a corporation cannot file a voluntary petition in bankruptcy, and thus defeat legal proceedings, and that, therefore, as the appellant is a corporation, it cannot be said to have 'suffered or permitted' what ensued from them. Regard, however, must be had to the whole of clause 3; and, in view of that, what the appellant 'suffered or permitted' was the sale of its property through legal proceedings. This was clearly the true act of bankruptcy, within the contemplation of the statute, although the statute is somewhat awkwardly expressed."

Views contrary to those held by the authorities I have cited are to be found in the dissenting opinion in *Wilson v. Nelson*, 183 U. S. 191, 22 Sup. Ct. 74, 46 L. Ed. 147, and in the opinion of the court in *Duncan v. Landis* (3d Cir.) 45 C. C. A. 666, 106 Fed. 839, opinion by Circuit Judge Gray, concurred in by District Judge Bradford, and dissented from in an opinion by Circuit Judge Dallas.

So far as I have been able to find, the only decision sustaining the contention of counsel for the defendant in this case is that of the circuit court of appeals of the Third circuit, in *Duncan v. Landis*, supra, (and that concurred in by two of the judges only), and *In re Nelson* (D. C.) 98 Fed. 76. The last case was overruled by the decision of the United States supreme court. *Wilson v. Nelson*, supra.

An order will be made adjudicating the Bradley Timber Company a bankrupt, and granting said company five days in which to present a bill of exceptions and petition for appeal and review, as it may be advised.

In re VARICK BANK OF NEW YORK et al.

(District Court, S. D. New York. January 14, 1903.)

1. **BANKRUPTCY—ACT OF BANKRUPTCY—PROCURING APPOINTMENT OF RECEIVER.** Obtaining the appointment of a receiver by an insolvent partnership through dissolution proceedings in a state court, though such action was taken for the purpose of preventing the bankruptcy court from obtaining possession of the assets, is not an act of bankruptcy, under Bankr. Act 1898, § 3a, cl. 1 [U. S. Comp. St. 1901, p. 3422].

In Bankruptcy. On creditors' petition in involuntary bankruptcy. Frederick M. Czaki, for petitioning creditors. Stern, Singer & Barr, for receiver of State Court.

ADAMS, District Judge. This is a petition by the creditors to have the alleged bankrupts, composing the firm of Burrell & Corr, adjudged involuntary bankrupts as individuals and as copartners. The allegations of bankruptcy were put in issue by answer and the matter referred to a Special Commissioner to take testimony and report.

It appears that while insolvent, the alleged bankrupts applied to the Supreme Court of the State of New York for a dissolution of the copartnership and the appointment of a receiver of all their assets, with the usual powers. An order was accordingly made by the State Court, dated August 16, 1902, appointing such receiver. On the 1st day of August, 1902, the creditors' petition was filed in this court. It is alleged therein:

"*First*, that the alleged bankrupts within four months before the filing of the petition herein and while insolvent transferred and disposed of assets, and did dispose, sell, secrete and remove same for the purpose of impeding, hindering, delaying and defrauding creditors. *Second*, that while insolvent and within four months of the filing of the petition herein they conveyed and transferred assets with intent to hinder, delay and defraud their creditors by means of a fraudulent and collusive proceeding or action brought by Burrell against Corr in the Supreme Court of the State of New York in New York County, in which action a Receiver was appointed upon the motion of one party and the consent of the other which action was instituted and prosecuted for the sole purpose of controlling their assets and placing them beyond the reach of their creditors and of distributing their assets in derogation of the terms and provisions of the Acts of Congress relating to Bankruptcy, etc. *Third*, that while insolvent and within said four months they transferred a portion of their property to various creditors with intent to prefer them over others of the same class."

The answer does not deny the insolvency but does deny any act of bankruptcy.

The creditors, in support of the petition, have shown that while insolvent, one of the alleged bankrupts instituted the action in the State Court against his partner for a dissolution of the copartnership and, upon the consent of the defendant, procured the appointment of a receiver therein who took possession of the copartnership assets. It may be inferred from the evidence that the proceedings were instituted for the purpose of preventing the bankruptcy court from obtaining possession of the assets, in the expectation by the insolvents that they would be able to make a better settlement with their creditors than they could through bankruptcy proceedings.

The question is, whether the acts of the alleged bankrupts fall within the provisions of section 3a (1) of the Bankruptcy Act [U. S. Comp. St. 1901, p. 3422], providing that acts of bankruptcy shall consist of having:

"(1) Conveyed, transferred, concealed, or removed, or permitted to be concealed or removed, any part of his property with intent to hinder, delay or defraud his creditors, or any of them."

The Commissioner has reported that in his opinion, the alleged bankrupts committed an act of bankruptcy in having the receiver appointed under the circumstances and that an adjudication should be ordered.

The determination of the question is not without difficulty in view of the insolvency and the apparent attempt to avoid the effect of the bankruptcy law; yet as these proceedings are entirely statutory, they must rest upon the provisions of the Act. It is conceded by the creditors that justification for an adjudication must be found in the section quoted.

In the Act of 1867, it was provided (section 39) that it constituted an act of bankruptcy for a person to suffer or procure his property to be taken on legal process with intent by such disposition of it to defeat or delay the operation of the Act, which was construed to cover the case of a person procuring his property to be taken possession of by a receiver of a State Court—In re Bininger, 7 Blatchf. 262, 3 Fed. Cas. 412,—but no similar provision is found in the present Act and it may properly be concluded that Congress did not intend that under such circumstances the property of insolvents should be subject to the provisions of the present Bankruptcy Law. None of the provisions of section 3a (1) have been violated by the proceedings of the alleged bankrupts, unless the words of the section be given a construction apparently contrary to the intention of Congress. My attention has not been called to any authority decisive of the point involved but the tendency of the courts is apparently adverse to extending the bankruptcy jurisdiction to cases not clearly within the provisions of the Law—In re Empire Metallic Bedstead Co. (D. C.) 2 Am. Bankr. R. 329, 3 Am. Bankr. R. 575, 95 Fed. 957; Id., 39 C. C. A. 372, 98 Fed. 981; In re Blair (D. C.) 3 Am. Bankr. R. 588, 99 Fed. 76; Vaccaro v. Bank, 4 Am. Bankr. R. 474, 43 C. C. A. 279, 103 Fed. 436; In re Baker-Ricketson & Co. (D. C.) 4 Am. Bankr. R. 605, 97 Fed. 489; Metcalf v. Barker (U. S. Supreme Court, Dec. 1, 1902) 23 Sup. Ct. 67, 47 L. Ed. —.

The petition is dismissed.

EDISON v. LUBIN.

(Circuit Court, E. D. Pennsylvania. January 13, 1903.)

No. 36.

1. COPYRIGHT—SUBJECT OF REGISTRY—SERIES OF PHOTOGRAPHS.

A series of photographs, arranged for use in a machine for producing a panoramic effect, are not entitled to registry and protection by copyright as a "photograph," under Rev. St. § 4952 [U. S. Comp. St. 1901, p. 3406].

In Equity. Suit for infringement of copyright.

Howard W. Hayes, for complainant.

Charles N. Butler, for respondent.

DALLAS, Circuit Judge. This case, having been set down for final hearing upon an agreed statement of facts, was, when reached, submitted upon the briefs of counsel, and is now for adjudication.

The question which is presented at the outset is, as I view it, a decisive one, and therefore no other need be considered. That question is: Is a series of photographs, arranged for use in a machine for producing them in panoramic effect, entitled to registry and protection as a photograph, under section 4952 of the Revised Statutes [U. S. Comp. St. 1901, p. 3406]? That section extended the copyright system to "any * * * photograph," but not to an aggregation of photographs; and I think that, to acquire the monopoly it confers, it is requisite that every photograph, no matter how or for what purpose it may be conjoined with others, shall be separately registered, and that the prescribed notice of copyright shall be inscribed upon each of them. It may be true, as has been argued, that this construction of the section renders it unavailable for the protection of such a series of photographs as this; but if, for this reason, the law is defective, it should be altered by congress, not strained by the courts. I understand that when this act was passed these groups of consecutive photographs were, practically speaking, not in existence; and, in the absence of any expression of the will of congress which can be applied to them, I am not at liberty to conjecture what further provision, if any, would have been made, if their creation had been foreseen.

Even, however, if the section to which attention has thus far been confined would, when separately considered, bear the interpretation which the complainant seeks to have put upon it, the penal section of the same act would inhibit the acceptance of that interpretation. I do not question the correctness of the general proposition that the remedial sections of a statute may be liberally construed, although it contain penal provisions which must be construed strictly. But we are not now concerned with the acts to be done or the steps to be taken to fix or enforce a penalty. Precise adherence to provisions respecting such matters can, of course, be rigidly insisted upon, although as to the others the greatest liberality of construction be indulged; but

¶ 1. Matter subject to copyright, see note to *Amberg File & Index Co. v. Shea, Smith & Co.*, 27 C. C. A. 248.

here the question is as to the thing in legislative contemplation, and, as that thing is designated in exactly the same way in both sections, it cannot be supposed that the one was intended to embrace any subject-matter to which the other could not be applied. It was the manifest purpose of congress to relate the grant of copyright and the liability to forfeiture to precisely the same production,—to make the right and the penalty for its invasion correspondent and correlative; and, therefore, as the words “any photograph,” as they occur in the penal section, must be literally applied, they cannot, as they occur in the previous section, be so defined as to bring a series of photographs within their meaning.

The bill of complaint is dismissed, with costs.

UNITED STATES v. CLAWSON et al.

(District Court, E. D. Missouri, E. D. June 18, 1902.)

No. 4,661.

1. REVENUE LAW—STAMP TAX—MEMORANDUM OF SALE—SALES BY AGENT.

Act March 2, 1901 (31 Stat. 943), provides that every corporation which shall in its own behalf, or as agent, conduct what is commonly known as a “bucket shop,” shall pay a stamp tax of 2 cents on each \$100 of the face value, or fraction thereof, of all stocks, bonds, or other securities covered, etc. *Held*, that where defendant commission company contracted with S. that the latter should open a separate office, and send trades obtained to defendant, and for his services defendant agreed to pay one-fourth of the commission charged to the customer, and S. received an order for stocks, which he transmitted to defendant, and which was filled by the latter, whereupon S. executed a memorandum of the sale, which he duly stamped, S. acted simply as the agent of defendant, and hence the latter was not guilty of a violation of the statute by reason of its failure to execute and stamp a memorandum of sale to S.

David P. Dyer, U. S. Dist. Atty.
Chester H. Krum, for defendants.

ADAMS, District Judge (directing verdict). This is an indictment under the provisions of the act of March 2, 1901 (31 Stat. 943). This act subjects any persons or corporations engaged in the business of making contracts, agreements, trades or transactions respecting the purchase or sale of provisions, stocks, or bonds, when no actual deliveries are contemplated, but when settlements are to be made according to future market quotations, to the payment of a certain annual tax for each office or place of business; and in addition thereto the act provides as follows:

“Every person, association, co-partnership and corporation who or which shall in his or its own behalf, or as agent, conduct what is commonly known as a ‘bucket shop,’ shall pay a stamp tax of two cents on each one hundred dollars in value, or fraction thereof, of the merchandise covered or pretended to be covered, and also a tax of two cents on each one hundred dollars of the face value, or fraction thereof, of all stocks, bonds or other securities covered or pretended to be covered by each and all of such contracts, agreements, trades or transactions.”

The defendants are charged with the offense of making a contract or transaction with one F. C. Swartz for the sale of 25 shares of the capital stock of the Union Pacific Railroad Company, without affixing a stamp upon the memorandum of such sale, denoting the payment of the internal revenue tax required by the act to be paid on such transactions. The defendants admit that they were engaged in the bucket-shop business, within the meaning of the act in question, but contend that they made no transaction with Swartz, such as is charged in the indictment. The undisputed evidence shows that the defendant Clawson was the manager of the defendant the Boyd Commission Company, and that his relation to the transaction involved in this case is that of such manager only; that this commission company had a contract or agreement with Swartz by which he was to secure business for it on joint account, and to receive a certain portion of one (and only one) commission to be charged on each transaction made by him for the commission company (I believe the evidence is that he was to receive one-fourth, and the commission company three-fourths, of each such commission); that Swartz was to keep a separate office, with private telegraphic communication between it and the office of the commission company; that no general business was to be done by Swartz, but, on the other hand, he was to work exclusively for the commission company. The method of transacting business was that Swartz should solicit or secure customers for the sale or purchase of provisions, stocks, bonds, or securities, and whenever he should secure a customer, or receive a proposition for the purchase or sale, immediately report the same to the commission company by the private wire; and, on its approval of the transaction, Swartz was to make the memorandum of sale or purchase, as the case might be, in his own name, and affix thereto the stamp denoting the payment of the requisite tax, and deliver such a memorandum to the customer. All margins received were to be forthwith delivered by Swartz to the commission company. Such is the uncontradicted testimony concerning the business relations between Swartz and the commission company. The immediate transaction made the basis of the present indictment is that one Loomis applied to Swartz, at his office, to purchase 25 shares of the Union Pacific Railroad stock. Swartz thereupon wired the commission company of Loomis' application, for its approval, and was forthwith advised of its approval and acceptance of Loomis' order. Thereupon Swartz executed the memorandum of sale in his own name, affixed the required stamp, delivered the same to Loomis, received the required margin, and in due course accounted to the commission company therefor. The books of the latter company showed the full transaction, and by the number ascribed thereto, coinciding with the number on the memorandum of sale executed by Swartz, rendered it entirely practicable and easy to trace the transaction so as to show that the one recorded in the books of the commission company was identical with the one disclosed by the memorandum of sale executed by Swartz.

From what has been already said, it is certain that Swartz, in the transaction with Loomis, acted as the agent of the commission com-

pany. It is true, he did not disclose the agency to Loomis, but this is of no significance in law. Loomis, on discovering the facts in the case, could have maintained an action (if otherwise available to him) directly against the undisclosed principal for the enforcement of his rights. But it is contended that, even if Swartz acted as agent for the commission company in the transaction, he, theoretically, at least, purchased the stock which he was to deliver to Loomis from the commission company, and therefore that the latter company was required by the provisions of the act of congress in question to make and stamp a memorandum of sale thereof to Swartz. To this contention I cannot give assent. If Swartz was agent of the commission company in the transaction, his act was the act of that company, and not his own. The transaction was the transaction of that company, and not the transaction of Swartz. He clearly could not, if the transaction was otherwise lawful, have maintained an action for the delivery of the stock in question to himself on the contract made by the commission company for delivery of the same to Loomis. There is no pretense that Swartz bought the stock of the commission company to "hedge" against his own liability to deliver an equal amount of stock to Loomis. If such were the case, there clearly would have been two transactions, each subject to taxation, within the meaning of the law. So it seems that in any phase of the evidence there was but one transaction, and that was a transaction between the commission company and Loomis, through Swartz, as an intermediary or agent of the commission company. To hold that there should have been two stamps, because, forsooth, Swartz represented to Loomis that he would sell him the stock, when he in fact intended to get the commission company to make the sale, would subject the transaction to double taxation.

My attention is called to a ruling of the commissioner of internal revenue, in which a different position is taken with respect to a transaction similar to the one now under consideration. I have the very highest respect for the opinions of commissioners who are constantly engaged in the consideration and administration of revenue laws. But in cases which find their way into court the responsibility rests with the court, and cannot be shifted to the shoulders of the commissioners. Being perfectly clear in my own mind that the transaction disclosed by the evidence in this case is a single transaction, I cannot treat it as involving two, and as requiring the payment of a tax by the principal, when the agent has already paid all the tax to which the single transaction is subject.

These observations are decisive of this case, but they must not be construed so as to permit of any evasion of the law. If the transaction is, in its substance and reality, a single transaction, there can be but one tax exacted from the parties to it. But care must be observed by parties who are making deals through an agent to keep their accounts of such transactions so as clearly to identify the one begun by an agent with that concluded by the principal. The books of the principal should in all cases be so kept as clearly to show that the order which the principal is filling is the very order which the agent took from the customer, and no different one. Where

that is perfectly clear and distinct, there ought not to be an imposition of a double tax. It is a single transaction, and a single tax is all that is necessary.

In the light of the uncontradicted evidence introduced in this case, the jury must return a verdict of not guilty.

HARRISON v. HUGHES et al.

(District Court, D. Delaware. February 5, 1903.)

No. 594.

1. CANCELLATION OF CHARTER PARTY—LIBEL BY MASTER—DAMAGES.

A libellant, as master of a vessel, should not be allowed to recover damages for loss resulting to its owners from the cancellation of a charter party, where the libel does not claim damages therefor, or mention such charter party; but the court may in such case allow an amendment of the interlocutory decree and, if necessary, refer the case to a commissioner to deal with the subject-matter of such amendment.

2. SAME—DETENTION OF VESSEL—INTEREST.

Interest can in the sound discretion of the court be allowed as part of the damages for the detention of a vessel for repairs where the libellant is entitled to damages on account of such detention, and should be allowed in the absence of special circumstances rendering it inequitable.

(Syllabus by the Court.)

In Admiralty. On exceptions to report of Commissioner.

John F. Lewis and Francis C. Adler, for libellant.

Harry Emmons and Anthony Higgins, for respondent.

BRADFORD, District Judge. The steamship *Glenochil* stranded on the new breakwater off Lewes in this district, November 30, 1897, thereby receiving much damage. This court, having held that the stranding was due to the negligence of both the steamship and the respondents, (110 Fed. 545) made an interlocutory decree that the libellant recover from the respondents one half of the damages and costs, and referred the case to a commissioner to ascertain, compute and report the same to the court. The commissioner has made his report allowing as part of the damages \$13,000 for "demurrage and portage charges for the detention of the *Glenochil* as a result of the stranding, as agreed upon by counsel", together with interest thereon at the rate of six per cent., and also \$763.99 for "loss arising from the difference of freight between the old and new charter party." The first item, so far as it relates to what is termed "demurrage" represents, not demurrage in its proper sense, but damages in the nature of demurrage for the loss of the beneficial use of the steamship during the period she was undergoing repairs. The second item represents damage for the loss by cancellation of the charter party under which the steamship was sailing at the time of the catastrophe, and is supposed to be equal to the difference between the freight she would have earned, had the stranding not occurred, and the freight she did earn or could have earned under a subsequent charter party executed after her repairs had been completed; freights having fallen after the

execution of the first and before the execution of the second charter party. The respondents have excepted to the findings and report of the commissioner, as follows:

"1. That the commissioner erred in awarding libelant the sum of seven hundred and sixty-three dollars and ninety-nine cents for loss arising from the difference of freight between the old and new charter party.

2. That the commissioner erred in allowing interest as a part of the damages on the claim for demurrage and portage charges for the detention of the *Glenochil* as a result of the stranding."

The damages claimed in the libel are set forth as follows:

"Sixth: The damages sustained by the said steamship by reason of the stranding aforesaid were very great. Her stem was broken, a large hole was stove in her port bow, and about forty plates were broken or damaged, several frames or ribs were broken, lower stringer and a large amount of other damage. A claim for salvage was made against the said steamship, and the sum of twelve thousand five hundred dollars has been awarded against her by the New York Board of Marine Underwriters, and the total damage, including the salvage due by the vessel, will amount to about fifty thousand dollars, to which is to be added damages for the detention of the said steamship from November thirtieth, 1897, the date of the stranding, to the time that her repairs will be completed, which as near as can be estimated at the present will be about March first, 1898, and the libelant alleges that the said steamship is entitled to be paid for such detention the sum of one hundred and fifty dollars per day, making a total for the ninety days, actual and expected detention, of about thirteen thousand five hundred dollars, making the total damages received by the said steamship from the stranding aforesaid the sum of about sixty-three thousand, five hundred dollars."

The damages thus claimed in the libel do not include, but on the contrary exclude, any claim for loss by reason of a cancellation of the charter party under which the steamship was proceeding at the time of the accident. Objection was taken on behalf of the respondents to the introduction of evidence on that subject during the examination of the witness Solari as follows:

"Q. 384. What was the loss in dollars and cents to the '*Glenochil*' by reason of the cancellation of the charter of November third?

Mr. Emmons: We object to that. The question here is, what loss did she sustain by reason of the collision."

The objection was overruled and evidence on the point was received. There is nothing in the libel alluding to or hinting at any cancellation of a charter party. Any loss occasioned thereby is strictly special damage which should have been alleged as well as proved. Courts of admiralty, it is true, are liberal in their treatment of pleadings, and averse to sustaining technical objections calculated to prevent the determination of causes according to their essential merits. But this liberality should be restrained within proper limits, and not so exercised as to prejudice either of the parties to a cause. If the libelant at the time of filing his libel intended to charge the respondents with the amount of loss caused by the cancellation of a charter party he should have set forth in his libel his claim in that regard. There is nothing in the libel which could advise or suggest to the respondents that such a claim would be made. They were entitled under the elementary rules of pleading to be informed at least of the character of any special damage for which the libelant sought compensation. The omission of any reference in the libel to loss

resulting from the cancellation of a charter party is not, however, an incurable defect. It may be supplied by a proper amendment. Leave is granted to the libellant, on two days' notice to the proctors of the respondents, to submit a proper amendment. If allowed, it may or may not be found necessary to refer the case again to the commissioner to deal with the subject matter of the amendment. If such amendment be not submitted to the court within ten days the first exception will be sustained.

The second exception relates generally to the allowance of interest by way of damages on the amount awarded for detention of the steamship and for portage charges. With respect to portage charges I can perceive no reason why interest should not be allowed, under the circumstances of this case, as part of the damages. The main contention on the part of the respondents in support of this exception relates to the allowance of interest by way of damages on the amount awarded for detention of the steamship during the period of her repairs, or on "the claim for demurrage" in the language of counsel. The commissioner allowed interest as "part of said damages". While there are some cases to the contrary, the decided preponderance of authority supports the proposition that interest can be allowed by way of damages in such a case in the sound discretion of the court, and should be allowed in the absence of special circumstances rendering it inequitable. *The M. Kalbfleisch* (D. C.) 59 Fed. 198; *The Natchez*, 24 C. C. A. 49, 78 Fed. 183; *Brent v. Thornton*, 45 C. C. A. 214, 106 Fed. 35; *The Jas. A. Dumont* (D. C.) 34 Fed. 428; *The Bulgaria* (D. C.) 83 Fed. 312. It is urged on the part of the respondents that the libellant has been guilty of such delay in bringing this cause to a hearing as to make it unjust to include interest in the damages for detention of the steamship. On careful examination of the record, in connection with certain correspondence between the proctors for the respective parties which, without objection by the respondents, was read at the hearing and handed to the court, I am not prepared to hold that there was such undue delay on the part of the libellant as to disentitle him to interest. The second exception must, therefore, be overruled.

THE PINE FOREST.

(District Court, D. Rhode Island. January 20, 1903.)

1. SALVAGE—RAISING SUNKEN VESSEL—SERVICES RENDERED BY OWNER OF VESSEL IN FAULT.

A barge, sunk through the fault of a tug, was raised by other vessels owned by the owners of the tug, there being no specific agreement between the parties in respect to payment for the services. Subsequently the tug was libeled for the loss, and the owners by proper proceedings limited their liability to her stipulated value. *Held*, that such limitation did not entitle them to recover for raising the barge as a salvage service, the work having been done in performance of a duty which they owed as owners of the tug to lessen the damage done so far as possible and for their own benefit in reducing the claim for damages, although even as so reduced it exceeded the amount of their liability as limited.

In Admiralty. Suit for salvage services.

Carver & Blodgett, for libelants.

Robert M. Morse and W. M. Richardson, for claimant.

BROWN, District Judge. This libel is for salvage services in raising the barge Pine Forest, which was sunk in Quick's Hole, Vineyard Sound, January 16, 1898. It has been determined by the United States district court of the district of Massachusetts that the Pine Forest was sunk through the fault of the steamtug Triton, owned by the Knickerbocker Steam Towage Company. The Triton herself took no part in raising the barge. By a stipulation it is provided that whatever defense there might be provided this libel were brought by the Knickerbocker Steam Towage Company, the owners of the Triton, the same will be a defense against these libelants. For the purposes of this case, the libelants may be regarded as the owners of the tug Triton, which caused the damage. The present case is, therefore, in substance, a suit by the owners of an offending tug to recover for services rendered by other vessels owned by them and employed by them in raising the barge. It is agreed that the value of the services is the sum of \$8,750, with interest. It thus appears that the owners of the offending tug, the Triton, caused the barge an item of \$8,750 damage, which damage they have repaired by furnishing \$8,750 of services. Under ordinary circumstances one claim would erase the other. The difficulty in the present case arises from the following facts: The barge was sunk January 16, 1898; work in raising her was begun on January 18, and continued to February 27, 1898; a libel against the Triton was filed in the district of Massachusetts on or after March 5, 1898, and in that case the owners limited their liability by stipulation to the sum of \$20,000, the agreed value of the Triton.

The libelants contend that, if they are not entitled to recover in this case, they are not entitled to limit their liability to the value of the vessel, but only to the value of the vessel plus such additional sum as they may have found necessary to expend in raising the Pine Forest.

Ordinarily a salvage reward is allowed for a service rendered to marine property by those under no obligation to render it. So far as I am able to see, the fact that owners may limit their liability can have, in this case, no bearing on the question whether they were working as salvors or in their own interest. Whether such a fact might have a bearing under circumstances which showed clearly, before the work of raising was begun, that the final damage was already in excess of the value of the offending vessel, and of the amount of its owner's statutory liability, is a question that we need not determine. It does not appear in this case that, upon the stranding of the barge, the owners of the tug knew that they had already suffered a loss equal to the value of their entire interest in the tug.

The claimant contends that the duty to relieve the barge was not a duty of the tug Triton alone, but a duty of the owners of the Triton. This contention is supported by the language of the circuit court of appeals for the Sixth circuit, in *Fleming v. Lay*, 48 C. C. A. 748, 109 Fed. 952: "It was the duty of the tug which had stranded the

schooner by its negligence, and through it the duty of the association, to relieve the vessel from the peril in which it had been placed." The association was the owner of a tug which, by negligent navigation, had brought a schooner into peril by stranding, and of other tugs which assisted in relieving the schooner. It was held that the services of the other tugs were rendered to the association, and not to the schooner, and that she was not liable therefor. Under similar circumstances, it would seem just to hold that the assisting vessels were working for their owners, in the discharge of their obligation, rather than that they should be regarded as independent salvors.

The evidence in the present case does not show any specific agreement that the work of raising the barge was to be the performance of an independent salvage service, rather than the performance by the owner with his own vessels of a duty owed to the barge. Upon the whole, it amounts merely to this: that the owner of the tug in fault, with the consent of the owner of the barge, undertook to relieve the barge from her peril. The value of the services was to be determined thereafter, but nothing was said as to ultimate responsibility, or as to the manner of payment, or whether the services should be offset against damages or paid in cash, or to indicate that any question of limited liability was in the mind of either party. The rights in the present case must be determined from the proofs as to the things which were done, rather than from any inference that can be drawn from the indefinite language used by the parties in their communications.

Usually, when a wrongdoer makes a physical repair or replacement of the thing injured, no pecuniary liability for damages arises, except for what is not restored. There is satisfaction to the extent of accepted repair. If the Triton's crew had negligently lost overboard the Pine Forest's anchor, and had then recovered it, they could make compensation for their negligence by restoring it, but they could not also make a claim for salvage. They must bear the labor resulting from their own negligence. So, if the libelants have sunk the barge and raised her and restored her, they make compensation to the extent of the restoration; but the labor in the work of recovering her is for their own benefit, in order that they may restore, and is not salvage service. As a matter of fact, there was, before the libeling of the Triton, a partial physical restoration of the barge, so that the outstanding claim of the barge owners was only for what had not been restored.

I know no reason why the libelants should be permitted to treat the value of the work done in order that they might restore as an outstanding pecuniary liability from which they may partially relieve themselves by proceedings for the limitation of liability. As repair proceeds, it extinguishes the obligation to pay damages. There can be no doubt that, in raising the barge and delivering her to her owners, the libelants were persons who were under a general obligation to relieve the vessel if practicable, and who were also liable to pecuniary loss to the extent of their interest in the tug Triton for any damage already done, and for any additional damage to the barge that might result from leaving her stranded. In raising her,

therefore, they were working for their own interest, and not as salvors. This is so, even if it were subsequently found that their entire pecuniary expenditure or loss would have been less had they abandoned the barge as a total loss. But for the intervention of the owners of the tug, one of the items of damage might have been a sum paid for raising the barge; but, as the owners of the tug themselves floated the barge and then delivered her to her owners, this item of damage was avoided, and was not an outstanding liability when limitation proceedings were begun. In *The Benefactor*, 103 U. S. 245, 26 L. Ed. 351, it was said: "A limitation proceeding must be regarded as ineffectual as to any specific party, if not undertaken until after such party has obtained satisfaction of his demand."

Libel dismissed.

FILES v. DAVIS.

(Circuit Court, E. D. Arkansas. January 24, 1903.)

1. ATTACHMENT BOND—SURETIES—LIABILITY.

Rev. St. U. S. § 995 [U. S. Comp. St. 1901, p. 711], provides that all money coming into the hands of an officer of the court must be deposited in the registry of the court; and section 996 [U. S. Comp. St. 1901, p. 711] provides for the manner of withdrawing the same. In attachment against several as partners, one of the defendants claimed sole ownership, and pleaded to the jurisdiction. Pending the proceedings the attached property was sold by order of court, and the proceeds deposited in the registry. The other defendants failing to defend, judgment was rendered against them. The attachment was sustained against all, and, as to the defendant who had filed the plea to the jurisdiction, the main action was continued. Without notice to him, the court ordered the money in the registry paid to the attaching plaintiff, which was done, and afterwards the plea to the jurisdiction was sustained. The attachment bond bound the sureties "to pay to the defendants all damages they or either of them may sustain by reason of the attachment if the order therefor is wrongfully obtained." *Held*, that the sureties were only liable for the value of the attached property, less the proceeds of the sale, and not for the sum erroneously paid to the attaching plaintiff.

Action against Surety on Attachment Bond.

This is an action against the surety on an attachment bond to recover damages alleged to have been sustained by the plaintiff, who was one of the defendants in the attachment suit. The facts, so far as they are necessary to a determination of the question involved, are as follows: George Scott instituted in this court an action by attachment against the plaintiff in this cause and some other parties, all of whom were charged to be partners. To obtain the attachment, Scott executed a bond, with the defendant's intestate as surety. The sole ownership of the property seized by the marshal under the writ issued is claimed by the plaintiff, who, in his answer in that cause, denied that he was a partner of the firm sued, or in any way liable in the action. He also filed a plea to the jurisdiction of the court. Pending these proceedings the attached property, which consisted of a stock of merchandise, was by order of court sold by the marshal, and the proceeds deposited in the registry of the court. The other defendants in that action failing to defend, judgment by default was rendered against them by the court, and the attachment sustained against all the parties, including this plaintiff, but as to the plaintiff in this action the main suit was continued. Without notice to this plaintiff, the then presiding judge of this court made an order directing that

the money realized from the sale of the attached property, then in the registry of the court, less the costs of the suit, be paid over to the attaching plaintiff, whereupon the clerk drew his warrant on the registry bank for the money, which was duly signed by the judge, for the sum of \$3,247.87, and paid over to Scott. Upon the hearing of this plaintiff's plea to the jurisdiction, the court sustained it; and the question now to be determined is whether the surety on the attachment bond is liable, as a part of the damages alleged to have been sustained by plaintiff, for the money erroneously paid to his principal out of the registry of the court.

Rose, Hemingway & Rose, for plaintiff.
Ratcliffe & Fletcher, for defendant.

TRIEBER, District Judge (orally). The question is novel, and one not free from doubt. Neither the learned counsel nor the court has been able to find any opinion directly in point. Had the marshal or a sheriff paid the money to the plaintiff before there was a final judgment against the party who was the real owner of the property, he would have acted at his own peril. Nor would there be any doubt as to the law were this an action against the original plaintiff in the attachment suit, for he, having received the money, would clearly be liable. But in the case at bar the only defendant is the surety on the attachment bond. The general rule is well settled, and requires no citation of authorities, that the liability of sureties will be strictly construed in their favor, and not extended by implication or construction. They are favorites of the law, and their contract is *strictissimi juris*. The question, therefore, to be determined, is, what liabilities did the sureties on the attachment bond assume when they signed the bond, and bound themselves thereby "to pay to the defendants all damages they, or either of them, may sustain by reason of the attachment if the order therefor is wrongfully obtained." The bond having been executed in a proceeding pending in a national court, the statutes of the United States, if there are any on the subject, must govern. Section 995, Rev. St. [U. S. Comp. St. 1901, p. 711], provides that all moneys coming into the hands of an officer of a court must be deposited in the registry of the court, and section 996 provides for the manner of withdrawing same. When the sureties signed the bond, what liabilities did they assume? In the opinion of the court, the liability they assumed was that, in case it is determined that the order for attachment was wrongfully obtained, they would cause their principal to pay, or upon his default they would pay, to the defendants the value of the property seized, with 6 per cent. interest thereon from the time of the seizure, less the net proceeds of the attached property sold, which money would remain in the custody of the court, in its registry, until a final determination of the cause. That the money in the registry would be paid out by an erroneous order of the court, they had no right to, and did not, assume. Nor did they bind themselves to make good damages sustained by the mistake of the court. The plaintiff in that action, who received the money wrongfully, is, no doubt, liable therefor to the plaintiff in this case; but, in my opinion, the sureties are not. Some very strong reasons have been advanced by learned counsel for plaintiff why

their client should not be held liable for the mistakes of the court induced by defendant's principal. But sureties being favorites of the law, and their liabilities strictly construed, the court must resolve all doubts in its mind in their favor.

The court is of the opinion that the defendant is liable only for the value of the goods taken from him under the order of attachment, with 6 per cent. interest from that date to this, less the sum of \$3,247.87 paid by the marshal into the registry of the court, which sum is to be credited as of the 29th day of April, 1901, the day the original attachment suit was dismissed, for on that date plaintiff would have been entitled to the money in the court.

In re SMITH.

(District Court, D. Rhode Island. January 14, 1903.)

No. 294.

1. BANKRUPTCY—PROPERTY VESTING IN TRUSTEE—CONDITIONAL PURCHASE BY BANKRUPT.

The trustee of a bankrupt has no equitable standing to enjoin the removal from a building of a steam engine which the bankrupt had not paid for, nor acquired the legal title to, without an offer to pay to the owner the unpaid purchase price.

In Bankruptcy. On trustee's petition for an injunction.

E. D. Bassett, for the trustee.

Edwards & Angell and E. P. Jastrane, for John W. Cole.

BROWN, District Judge. The trustee of Edward E. Smith, bankrupt, seeks to enjoin John W. Cole from taking by replevin and removing from a certain building a steam engine. The evidence shows clearly that the bankrupt acquired no legal title to the engine. The trustee contends, however, that it has been so attached to the real estate that it has lost its character as personal property. While I am of the opinion that, in view of the contract between Smith and Cole, and of the removable character of the engine, it did not become part of the realty, yet, even if we concede that it did, the trustee can have no equitable standing without a tender to Cole of the unpaid balance of the contract price. The asset which the trustee seeks to protect is, upon his contention, composed of the bankrupt's right to purchase certain real estate, and of Cole's steam engine added thereto; but the bankrupt had neither legal nor equitable title to Cole's engine, and if, in any way, there could be accomplished the merger of Cole's engine and the right of the bankrupt to purchase the real estate according to the contract with McCrillis, the whole resultant asset would not belong to the bankrupt or his creditors. Cole would be the equitable owner of said asset to the extent of the value contributed by him thereto, which would be at least the amount of the unpaid balance of the contract price for the engine. Without an allegation of willingness and ability of the trustee to make payment to Cole of the unpaid balance, the petition presents no case for equitable relief.

Petition denied.

DAILEY et al. v. CITY OF NEW YORK.

(District Court, S. D. New York. December 8, 1902.)

1. ADMIRALTY—BRINGING IN NEW DEFENDANTS—CASES OTHER THAN FOR COLLISION.

The principle of the fifty-ninth admiralty rule, which permits the bringing in of new parties in collision cases on petition of the claimant or respondent, will be applied by analogy in other cases by requiring the appearance of any additional defendant who may be responsible for the claim sued for or a part thereof.

In Admiralty. Suit for salvage. On petition by respondent to bring in new party.

George L. Rives, for the motion.
Alexander & Ash, opposed.

ADAMS, District Judge. This was a libel in personam against the City of New York for salvage alleged to have been rendered to Scow "D" belonging to the City, by the libellants' Tug "Mattie." It appears that the Mattie found the scow adrift in the East River and it is alleged rendered services to her for which the salvage is sought to be recovered. The City alleges by a petition that the scow was cast adrift by the negligence of other parties and asks that process be issued against them and that they be made respondents in the action, under, or by analogy to, the 59th Rule in Admiralty. This is opposed by the libellants upon the ground that the rule is confined to cases of collision and that they should not have their right of action impeded by side issues. It is true that the rule in terms does not provide for other than collision cases, but the principle upon which it is based is applied by analogy in other cases to assist in the administration of justice by requiring the appearance of any additional defendant who may be responsible for the claim or a part thereof. The *Alert* (D. C.) 40 Fed. 836; *The Centurion* (D. C.) 57 Fed. 412; *Salisbury v. Seventy Thousand Feet of Lumber* (D. C.) 68 Fed. 916; *In re New York & P. R. S. S. Co.*, 155 U. S. 523, 15 Sup. Ct. 183, 39 L. Ed. 246; *Christie v. Coke Co.* (D. C.) 92 Fed. 3; *Hastorf v. Supply Co.* (D. C.) 110 Fed. 669. It was so applied by this court in a very similar case to the one under consideration. *The Public Bath No. 13* (D. C.) 61 Fed. 692.

Motion granted.

 HOWE v. LARKIN et al.

(Circuit Court, D. Rhode Island. January 20, 1903.)

No. 2,643.

1. LANDLORD AND TENANT—COVENANT FOR RENEWAL OF LEASE—UNCERTAINTY.

A covenant in a lease by which the lessor agreed to renew at the expiration of the term for a stipulated rental, "subject to certain covenants, provisos, and agreements to be decided upon at that time between the said parties, not embodying in said agreement for a further lease any of the conditions or agreements contained in this present lease," is void for uncertainty.

At Law. On demurrer to declaration.

John W. Sweeney, for plaintiff.

Walter B. Vincent, for defendant.

BROWN, District Judge. This action is for breach of a covenant contained in a lease of a hotel in Westerly, R. I., known as the "Larkin House." The principal question raised by demurrer is whether the covenant in question is void for uncertainty. As each count makes specific reference to a copy of the lease brought into court by the plaintiff, it is unnecessary to make distinctions between the counts. Certain of the counts purport to set forth the substance of the covenant, but in so doing omit any express reference to material parts thereof. The plaintiff's case cannot be aided by such omission, since the omission is supplied by reference in each count to the copy of the lease. The covenant is as follows:

"And at the expiration of the term aforesaid the said lessor agrees to make, execute, and deliver to the said lessee a new and fresh lease of said demised premises, provided the same are not sold, for a further period and term of five years, at the rate and price of five thousand dollars (\$5,000.00) for each year, and under and subject to certain covenants, provisos, and agreements, to be decided upon at that time, between the said parties, not embodying, in said agreement for a further lease, any of the conditions or agreements contained in this present lease."

I am of the opinion that this covenant is void for uncertainty, since, while it expressly negatives a present agreement that the new lease shall contain the conditions and agreements of the old, it contains nothing upon which even a conjecture can be based as to what covenants, provisos, and agreements are intended by the parties to be included in the new lease. It is a mere agreement to make an agreement upon undefined subject-matter. Upon this view, it is unnecessary to consider the remaining questions.

Demurrer sustained on the fourth ground.

KILGORE et al. v. NORMAN et al.

(Circuit Court, S. D. Georgia, E. D. August 7, 1902.)

1. EQUITY JURISDICTION—REMEDY AT LAW—SUIT TO RECOVER LANDS.

A federal court of equity has jurisdiction of a suit to recover lands, although complainants claim the legal title, where defendants also show a legal title, good upon its face, through deeds executed by an attorney in fact for complainants, but which the latter allege to have been executed in fraud of their rights, as the result of a conspiracy between such attorney and defendants, and the cancellation of such deeds is a part of the relief sought.

2. EQUITY—MULTIFARIOUSNESS OF BILL.

A bill by the heirs of a husband and wife to recover lands is not multifarious because the title to some of the lands was vested in the husband, to some in the wife, and to some in both, nor because defendants claim through various sources of title.

3. JURISDICTION OF FEDERAL COURTS—BURDEN OF PROOF—EVIDENCE TO OVERCOME JURISDICTIONAL AVERMENTS.

Where a bill in a federal court contains the necessary averments to give the court jurisdiction on the ground of diversity of citizenship, and

no plea to the jurisdiction is interposed, but the question is raised for the first time on a hearing, the burden of proof rests upon the defendants to disprove such averments; and affidavits of unknown witnesses, who have not been subjected to cross-examination, obtained by a person shown to have resorted to questionable methods, will not be accepted as sufficient against positive testimony in contradiction.

4. INJUNCTION PENDENTE LITE—RESTRAINING TRESPASS BY CUTTING TIMBER.

Where the issues in a suit in equity to recover timber lands are such that they can be properly determined only after a full hearing, but complainant shows an apparently strong case, and it appears that defendants have erected sawmills on the lands, an injunction restraining further trespass by the cutting of timber pending final hearing will not be dissolved unless a sufficient bond is given by defendants to protect complainant's rights.

In Equity. On motion to dissolve preliminary injunction.

John I. Hall and Olin J. Wimberly, for complainants.

Washington Dessau, Nathaniel E. Harris, Joseph Hamsell Merrill, and Matt J. Pearsall, for respondents.

SPEER, District Judge (orally). It has been announced during the argument that the court would take the case under advisement before pronouncing the decision. The hearing has contained so much of detail, and the arguments have been so fully made, that this is not now deemed necessary.

There are certain questions, which have been argued in extenso, about which the court has no difficulty. One is the contention that there is no equity jurisdiction here, because there is a remedy at law. This is not true, in the opinion of the court. The proceeding is, as contended, in part for the recovery of a large number of lots of pine land. It is also true that the complainants rely upon their legal title, having its origin in a grant from the state, with sufficient conveyances and clearly shown inheritable rights, vesting the title in them. It is not true, as contended, that they could have recovered on their title at law, because they would have been confronted with deeds made to the respondents by the agent or attorney in fact of Mrs. Caroline Kilgore, viz., one H. M. Hitt. This man was empowered by Mrs. Kilgore to recover these lands. He was also empowered to dispose of them for her benefit. Thus, upon the face of the papers, the respondents' deeds would at common law afford a complete answer to the complainants' claim of title. It is, however, true that the bill charges that the lands were conveyed in absolute disregard of the complainants' rights, and as a result of a conspiracy between the respondents and this agent, Hitt. This conspiracy is set out in detail, and there is much proof to support the charges. If there was such a fraudulent conspiracy with the agent of complainants, if the respondents were co-conspirators, and if the deeds were made as the result of such conspiracy, it is obviously a case in which the complainants have a right to invoke the powers of a court of equity to avoid and cancel the deeds made in its execution. The complainants could not, in a court of law of the United States, set up such an equitable reply to the apparently legal, though fraudulent, title of the respondents, as would suffice to secure the com-

plainants' rights. It is, however, competent for them to do this upon such a bill as that before the court. Nor is it sufficient to defeat the bill to point out a remedy at law. It must appear that the remedy at law is in all respects as complete as that in equity.

Nor is the bill multifarious. This is a proceeding on the part of the heirs of a husband and wife to recover lands, the title to which was either in the husband or in the wife, or both. There is nothing multifarious in a title devolved through the law of inheritance, when the title is vested in one or the other or both of the parents of the person suing. It is said, however, that the bill is multifarious because the defendants have a multitude of titles from different sources. It, however, cannot, we think, be insisted, because an answer is multifarious, that the bill itself is obnoxious to that objection,—an objection always addressed to the discretion of the court.

It is, moreover, contended that the court has no jurisdiction because the proper diversity of citizenship is not shown. Evidence in the form of affidavits has been produced to show that two of the complainants were residents of this state, and, since they are necessary parties to the bill, it is contended that the relief sought must be denied for want of jurisdiction. Prima facie the court has jurisdiction, because the sworn averments of the bill set out the essential jurisdictional facts. There is evidence to support these averments. No plea of the jurisdiction was filed, and this defense is presented for the first time on this hearing. It seems, therefore, that the burden of proof is on the defendants to show that the averments of diversity of citizenship by the complainants are not true. Does the evidence sustain that burden? I do not think so. It is presented in the form of affidavits, and, of these affidavits, it is uncontradicted that all but one was secured by one of the attorneys for the defendants, a Mr. Shipp, who, according to the undisputed testimony, resorted to questionable methods. Affidavits have been introduced to the effect that, although an attorney for the respondents, he went to one of the complainants, Mrs. Kilgore, gave a fictitious name, sought to win her confidence by stating that he came from the office of Hall & Wimberly, her attorneys, and endeavored to procure from her an affidavit to the effect that she was a citizen of Georgia; giving therefor the fictitious reason that otherwise her land would be sold for taxes. It is obvious that, had this attempt been successful, it would have greatly prejudiced, had it not wholly defeated, her right to proceed in this court. This attorney had ample opportunity to reply to these affidavits, and no reply was given or attempted by him, or by any one of the solicitors for respondents. Now, the court knows nothing of the character of any of the witnesses from whom the affidavits on this point were obtained. There is before us the testimony of the complainant and the testimony of her relatives that she had, in point of fact, in good faith removed to Alabama, and lives there now. The witnesses on whom the respondents rely to defeat jurisdiction on this point have not been subjected to cross-examination, and, under the present state of the case, the court, in view of the character of the affidavits, and the conduct of Mr. Shipp in obtaining them, does not feel justified in deciding that there was not a proper diversity of citizenship. This ques-

tion ought to be determined upon full proof, when the parties have had the right to examine and cross-examine the witnesses to establish the necessary and essential facts. This is, indeed, true with regard to all of the controverted issues in this case. It is not a case upon which the court can express a definite and final opinion upon the issues raised. While the evidence seems to preponderate in favor of the complainants, it is important that full proofs should be submitted. This is particularly true with regard to the issues raised as to the forgeries of the respondents' deeds. A number of deeds under which the defendants claim title are apparently forgeries. Some of these, by the respondents' counsel, are conceded to be forged. These, certainly, are exceedingly suspicious instruments. The bill charges a conspiracy to take possession of these lands, and, as one means of holding them, to rely on forged and fraudulent title deeds. While most of the respondents' deeds, save those executed under the power of attorney, seem to be forgeries, the court thinks that this is a case where the evidence on this important point should be carefully taken, and the witnesses subjected to examination and cross-examination before the examiner. So, too, with regard to the quintuple agreement on the part of five of these respondents. This, on its face, purports to be an explicit understanding between Hitt, the agent of Mrs. Kilgore, and four others, to sell her lands, and to divide the proceeds among themselves. It has been declared to be the germinating center of the alleged fraud complained of. An innocent interpretation has been placed upon this agreement by defendants' counsel. Upon its face, it does not seem to be susceptible of that interpretation; and whether it is so susceptible of such construction, as was insisted, and whether the titles made under it are valid, can only be determined after the proofs are taken and considered.

An injunction has been granted in this case, and, after the complete hearing we have had, the opinion of the court is that the injunction was proper, and must be continued. It is true that there are circumstances in this case which take it out of the ordinary category of applications to enjoin trespass by the cutting of timber. The law on this subject is fully stated in the case of *Camp v. Dixon*, 112 Ga. 882, 38 S. E. 71, 52 L. R. A. 755. It is, in view of that decision, and the general principles of law which it enunciates, a proper case to restrain a trespass of this character. But it is also true that the complainants claim title to large bodies of land which for a number of years they did not protect. They paid no taxes on these lands, and exercised no control over them; and not until the lands became valuable, owing to the rapid increase of population in that section, did the complainants come forward to establish what seems *prima facie* to be their legal title to these lands. As one result of this negligence on their part, sawmill men, who are respondents, have obtained control, in one way or another, of these lands. They have built their sawmills, laid down tramroads, making large expenditures, and are proceeding to cut the timber. This being true, it is the duty of a court of equity to conserve as far as possible the rights of all the parties, without unnecessary injury to any. With this view, while continuing the injunction in this case, it will be done under

conditions which will permit these respondents who are engaged in the sawmill or turpentine business to give bond, with good security, in sufficient amount to compensate complainants for any damages to them, which may be ascertained and determined by the final decree. On the execution of this bond the injunction will be set aside, and the respondents may go forward with their business. This seems to be an equitable exercise of the discretion of the court. The values in controversy must be ascertained, in order to determine what the amount of that bond shall be. If this can be agreed upon between counsel, the court will fix the bond in accordance with the sum agreed to. If it cannot be agreed upon, evidence must be taken to ascertain the values in dispute, so that the bond may be fixed at the proper amount. Until this is done, the injunction must be continued as of force at present.

In re SHACHTER.

(District Court, N. D. Georgia. December 8, 1902.)

1. BANKRUPTCY—FAILURE OF BANKRUPT TO SURRENDER PROPERTY—CONTEMPT—EVIDENCE.

On a rule for contempt against a bankrupt for failure to deliver all of his property to the trustee, evidence reviewed, and *held* to justify a finding that he had unlawfully retained goods of the value of \$1,063.94, which he should be required to surrender.

2. SAME—JURISDICTION.

A federal district court, sitting as a court of bankruptcy, has jurisdiction to proceed against a bankrupt for contempt, where he has failed to turn over all of his property to the trustee.

In Bankruptcy. Rule for contempt.

Mayson, Hill & McGill, for movants.

Slaton & Phillips, for bankrupt.

NEWMAN, District Judge. This is a rule for contempt against Joseph Schachter, against whom a petition in involuntary bankruptcy was filed on September 16, 1902, and who was subsequently, on October 7th, adjudged a bankrupt. This rule for contempt was filed on September 17th, the next day after the petition in bankruptcy was filed, and after the receiver was appointed to take charge of the stock of goods of the bankrupt. The substance of the petition against the bankrupt, now under consideration, and of certain amendments filed thereto, is that the bankrupt had possession or control of a considerable amount of merchandise and cash, which he was secreting, and had failed to turn over to the receiver. The bankrupt appeared in response to the rule, and was represented by counsel. A considerable amount of evidence was offered by the petitioning creditors who brought the rule, and the bankrupt testified at considerable length in his own behalf. While the testimony of a brother of the bankrupt, Philip Schachter, was being taken, it developed that a considerable amount of money had been deposited in the Fourth National Bank of Atlanta in the name of Philip Schachter, which had been given to Philip by the bankrupt, \$100 of it on the day the petition in bankruptcy

was filed, \$500 on September 12th, and \$825 on September 13th. All of this money had been quite recently withdrawn from the Fourth National Bank, and, after Philip Shachter on the stand had made several contradictory statements about the matter, it finally resulted that the wife of the bankrupt, who was in court, produced and gave to the clerk of the court, through the bankrupt's counsel, \$895 in currency which she had on her person, and which it was conceded was a part of the money given by the bankrupt to Philip Shachter, and by Philip Shachter deposited in the Fourth National Bank in his name, and subsequently withdrawn. Philip Shachter produced while on the stand a check for \$500 given by one Philip Elson, on the Fourth National Bank, for \$500, which he stated also represented a part of the money so withdrawn. This check was cashed by the clerk by consent of counsel, and this amount of \$500, together with the \$895, subsequently turned over to the receiver in this case. Thirty dollars, therefore, of the \$1,425 was unaccounted for, and had been used in some way after it was withdrawn from the bank.

The claim for the petitioning creditors is that the bankrupt had quite recently, during the month of August and in September prior to the filing of the petition in bankruptcy, bought a large amount of new goods, and that at the time the petition in bankruptcy was filed a very considerable amount of this new stock was not in the store, although it had so recently been delivered there. The evidence shows that the bankrupt had recently purchased \$7,807.94 worth of new goods, all of which goods were delivered in the store from the 19th of August up to the day before the petition in bankruptcy was filed. One bill, amounting to \$215, was delivered at the store August 19th, and one, amounting to \$291, was delivered on August 23d. All the other new goods purchased were delivered subsequent to August 24th.

For the purpose of being used on the hearing of this rule, the receiver was directed to have an inventory made of the stock of goods on hand when the receiver was appointed. The goods on hand were valued by the appraisers at \$2,750, and there was an additional amount for fixtures. It is claimed that neither the amount allowed for goods nor for fixtures represented the costs; but it is immaterial about this, in the view I have taken of the matter. It may be assumed for present purposes that the bankrupt had sold none of his old stock whatever from the time he began to receive new goods up to the time the receiver was appointed and took charge. If he had sold any of the old stock which he had on hand when he began to receive the new goods, it would simply operate against him, and make him account for more cash than I shall hold him responsible for.

The bankrupt had bought, as stated, \$7,807.94 of new goods, which had been delivered, as shown by the railroad receipts, to his store, and had become a part of his stock. Several invoices of goods were either in the depots in Atlanta when the receiver was appointed or were delivered afterwards, and have been since either stopped in transit or turned back by the court to the sellers, upon the ground that it was clearly a case in which no title had passed, under the circumstances of the case, to the bankrupt. Persons familiar with the bankrupt's stock, especially one gentleman who had worked for the bankrupt in

May and June, were questioned as to the amount of new goods in the store at the time the inventory was taken. The highest amount placed on the new goods in the store by any one was \$300 or \$400, the gentleman most familiar with the stock putting it at much less than this amount. For the purpose of dealing with the utmost fairness with the bankrupt in this proceeding, I shall assume that there were \$500 worth of new goods in the store at the time the receiver took charge, although there is no reliable evidence whatever in the record from which to conclude that it amounted to over \$400.

The bankrupt took the stand in his own behalf, and undertook to account for the disappearance of these new goods in so short a period, and his explanation was this: He said he had sold, and he read from a slip of paper which he held in his hand the names of parties to whom he had sold, goods which cost in the aggregate \$4,344, and from which he had received \$2,059 in cash, and \$574 was still due him by persons to whom he sold the goods. A calculation shows that the goods were sold, according to his own statement, for 29 per cent. below cost. The goods were sold, according to the statement of the bankrupt, in lots to peddlers, whom he named, as follows: Bressler, Constangy, Feldman, Niesbaum, Lavigne, P. Stein, Yallowitz, Bloomberg, Gritzman, P. Ruse, Zadick, Morris, A. Feller, John Robinson, Beaman, and Sinkovitz. The bankrupt in his evidence said that he did very little business during July and August, except what he sold at wholesale. He says: "Some days I didn't take in two dollars. The most of it I sold at wholesale to peddlers." But his counsel claim that he ought to be allowed for goods sold in the ordinary course of business in the store, \$1,500, from which they say he would have realized \$1,197. How this calculation is made does not appear in any way, and, so far as I can see, it is not supported by the evidence; but I shall give him the benefit of it for the purpose of disposing of this rule. This \$1,500 will be added, therefore, to the \$4,344, making \$5,844.

The bankrupt claims that he had shipped \$400 worth of these new goods at cost price to his brother I. M. Shachter, in Jersey City, N. J., to pay on an indebtedness to his brother. Allowing him the benefit of this very doubtful transaction, it would increase the amount of these new goods accounted for to \$6,244. Assuming that in the stock turned over to the receiver there was new goods amounting at cost price to \$500, this would make an aggregate of \$6,744, and this is allowing the bankrupt everything he claims as to goods sold and shipped out in lots, his counsel's own estimate as to the amount sold in regular trade, and a very liberal estimate for new goods on hand. The balance unaccounted, therefore, of the goods received in the store within a few weeks before the bankruptcy proceedings were instituted, is \$1,063.94.

Of course, this conduct of the bankrupt in selling the new stock of goods received in his store, in the way he did, is very remarkable. For instance, he sold to his brother-in-law, Bressler, \$600 worth of goods for \$400, just a few days before the petition in bankruptcy was filed. He owed one Constangy, he says, \$450, which he got from him in August, and he gave him \$685 worth of goods for that the 1st of September. He says:

"I sold a fellow by the name of Felman, a peddler here in Atlanta, \$150 worth, and I got \$125 in cash for it. I sold a fellow by the name of Niesbaum, on Decatur street, \$250 worth. He sells blankets and skirts. I got \$200 cash for that. I sold a fellow by the name of Lavigne \$145 worth, and he gave me \$100 in cash."

His testimony is a little uncertain, but he seems to have sold a man named P. Stein \$460 worth of goods for \$300 cash. He says:

"I sold a fellow named L. Yallowitz who lives in Abbeville, S. C., and peddles around, \$265 worth for \$165. He was here about two weeks ago. I sold a fellow named J. Bloomberg \$316 worth, and I got \$200 for it. I sold a fellow named Gritzman \$389 worth, and he paid me \$115. I sold them for less than cost. I sold a fellow named P. Russ, who peddles here in town. \$290 worth of goods for \$155."

He says he sold two fellows named Zadick \$165 worth for \$115.

These sales were all probably of new goods which had been in his stock but a few days at the time of the sale. There was no evidence, however, to controvert his statement, and he has been given, as stated, the full benefit of his evidence as to the disposition of these goods.

It is claimed by counsel for the movants in this rule that the bankrupt has cash which he has failed to turn over to the receiver, and a calculation is made by which it is sought to be demonstrated that this is true. I have gone with great care over the figures made by counsel for both sides, and over the bank book, checks, etc., and have made some calculations of my own, but I am unable to see from all this that the bankrupt necessarily has any cash in his possession. No books were kept by the bankrupt such as would throw any light on the question. It appears from a comparison of his bank book with the checks which have been produced, and which I have before me, that many checks are missing. What those checks were for it is impossible to say, or what became of the considerable amount of money the bankrupt received during the latter part of August and the half of September covered by this investigation. In addition to the amount of cash received by the bankrupt from the sale of goods in lots to peddlers, and the amount received in regular and ordinary sales from day to day, and any amount he may have had on hand in cash at any period from which a computation would commence, he received \$3,000 in cash just before the bankruptcy proceeding was instituted, from the sale of a house and lot. The only cash which the evidence shows to my entire satisfaction that the bankrupt had in possession at the time the receiver was appointed is that which has been already paid into court.

My conclusion is that the bankrupt has in his possession and control, and which he has failed to turn over to the receiver, goods of the value of \$1,063.94, which he should be required now to turn over to the trustee in bankruptcy.

Upon the question of this being a proper case for proceeding against the bankrupt as for contempt, counsel for the bankrupt in this case rely upon the recent case of *Boyd v. Glucklich*, 8 Am. Bankr. R. 393, 116 Fed. 131, decided by the circuit court of appeals for the Eighth circuit, and especially upon the reasoning of Circuit Judge Caldwell for the majority of the court. I have examined that case carefully, and find nothing whatever, even in Judge Caldwell's opinion, which denies the right of the court, in a proper case, to proceed as for contempt

against a bankrupt who wrongfully refuses to turn over assets to a receiver or to a trustee in bankruptcy. A majority of the court seem to have commented upon the fact that insufficient notice was given, and that the proceedings were summary to an extent not justified by the circumstances. Circuit Judge Sanborn in a concurring opinion says:

"I concur in the order reversing the orders below, because the evidence in the record satisfies my mind, beyond a reasonable doubt, that the bankrupt had in his possession or under his control at the time the order of the referee was made a much larger amount of property that belonged to his estate in bankruptcy than the amount which the court finally ordered him to surrender to the trustee. The rule by which this issue is to be determined is that the property of the bankrupt estate traced to the recent possession or control of the bankrupt is presumed to remain there until he satisfactorily accounts to the court for its disposition or disappearance. He cannot escape an order for its surrender by simply adding perjury to fraudulent concealment or misappropriation. It is still the duty of the referee and of the court, notwithstanding his oath and testimony, if satisfied beyond a reasonable doubt that he has property of the estate in his possession or under his control, to order him to surrender it to the trustee, and to enforce that order by confinement as for contempt. These rules are established and illustrated by the following cases: *In re Salkey*, 21 Fed. Cas. 235, 238-240 (Nos. 12,253, 12,254); *In re Schlesinger*, 4 Am. Bankr. R. 361, 42 C. C. A. 207, 208, 102 Fed. 117; *Id.* (D. C.) 3 Am. Bankr. R. 342, 97 Fed. 930, 932; *In re Deuell* (D. C.) 4 Am. Bankr. R. 60, 100 Fed. 633, 634; *In re Greenberg* (D. C.) 5 Am. Bankr. R. 840, 106 Fed. 496; *In re McCormick* (D. C.) 3 Am. Bankr. R. 340, 97 Fed. 566, 567; *In re Mayer* (D. C.) 3 Am. Bankr. R. 533, 98 Fed. 839, 841."

These views of Judge Sanborn are in accordance with the views of a majority of the circuit court of appeals for this circuit, as stated in *Re Purvine*, 37 C. C. A. 446, 96 Fed. 192, and also in the cases cited by Judge Sanborn and set out in his opinion as quoted above. See, as probably controlling on this question, *Mueller v. Nugent*, 184 U. S. 1, 22 Sup. Ct. 269, 46 L. Ed. 405.

In the case now under consideration, the bankrupt was given the fullest opportunity to be heard and to account for the disposition of his stock of goods. The petition was regularly filed against him, he was served, appeared by counsel and answered the rule, and had all the time he desired to present his side of the case. The case was postponed from time to time by the court in order to get a full hearing and accommodate counsel, as well as for the convenience of the court. Since the hearing was concluded counsel on both sides have been given full opportunity to present briefs and calculations. The court has had the matter under advisement for some time, and the conclusion above reached is after the fullest consideration of the case and of the evidence submitted. The present case measures up exactly to the rule stated by Judge Sanborn, as follows:

"The rule by which this issue is to be determined is that the property of the bankrupt estate traced to the recent possession or control of the bankrupt is presumed to remain there until he satisfactorily accounts to the court for its disposition or disappearance."

Making every possible allowance here in favor of the bankrupt, goods of the value above stated are wholly and entirely unaccounted for, and went into the possession of the bankrupt, some of them within a very few days, and all of them within three or four weeks, before the

receiver took charge and their absence was discovered. The fact that the bankrupt denies having the goods in his possession or control certainly cannot be conclusive, when the circumstances are overwhelming to the contrary. If so, the court would be powerless, in the face of the bankrupt's oath, to require the production of property, however conclusive might be the evidence that such property was in his possession or control.

An order may be taken in accordance with what is herein stated.

UNITED STATES v. ALEXANDER.

(Circuit Court, N. D. Georgia. October 3, 1902.)

1. CRIMINAL LAW—TRIAL—MISCONDUCT OF DISTRICT ATTORNEY.

Where, at the time an objection was made to the argument of an assistant district attorney, the court, in the presence of the jury, stated to the attorney emphatically that the language was improper, and ought not to have been used, and no further action was requested by defendant and no exception taken, such argument is not ground for a new trial.

E. A. Angier, U. S. Atty., and Geo. L. Bell, Asst. U. S. Atty.
Pledger, Johnson & Malone, for defendant.

NEWMAN, District Judge. This is a motion for new trial. The defendant was charged with stealing and embezzling certain money, the property of the United States, from Maj. P. C. Stevens, paymaster in the United States army. No exception whatever was taken, and nothing was urged on the argument of the motion for new trial against the charge of the court. The defendant's counsel concede that the case was fairly and properly submitted to the jury.

The only real grounds urged are that the verdict is not supported by the evidence, and the ground made, by an amendment to the motion for new trial, that the assistant district attorney, in concluding the argument to the jury, used improper language, which tended to the prejudice of the defendant.

As to the first ground, that the verdict is not supported by the evidence, I do not think it meritorious. The jury found the defendant guilty, and, in my opinion, the evidence was sufficient to support their finding, and the court should not interfere with the verdict.

In reference to the improper language claimed to have been used by the assistant district attorney in his argument to the jury, the attention of the court was called by one of defendant's counsel to the use of this language immediately after the expressions were uttered, and the court stated to counsel; in the presence of the jury, in the most emphatic way, that the language was improper, and ought not to have been used. No further action by the court was requested, and no exception whatever was taken. On the contrary, defendant's counsel seemed entirely satisfied with the action of the court at the time. If further action by the court had been desired it should have been requested, and if refused an exception noted. *Crumpton v. U. S.*, 138 U. S. 361, 11 Sup. Ct. 355, 34 L. Ed. 958.

I do not believe that the defendant was prejudiced in the slightest by the remark of the assistant district attorney. In my opinion, if it had any effect at all it was against the prosecution, and in favor of the defendant.

KING et al. v. SOUTHERN RY. CO.

(Circuit Court, N. D. Georgia, E. D. June 5, 1902.)

No. 1.

1. FEDERAL COURTS—JURISDICTION—AMOUNT INVOLVED.

In an action to recover a piece of land on which a railroad had located its depot, the value of the land to the railroad company, according to its present situation and use, is the value to be considered in determining whether the amount involved in the litigation is sufficient to confer jurisdiction on the federal courts.

On Motion to Remand to State Court.

J. C. Edwards, for plaintiffs.

Sanders McDaniel and J. J. Bowden, for defendant.

NEWMAN, District Judge. This motion to remand raises the question of the value of the property in dispute. It is a suit by the plaintiffs against the defendant to recover a piece of land at Cornelia, Ga. On the land in controversy is located the defendant's depot at that point, and it is the junction also of the defendant's road with the Tallulah Falls Railway. The matter has been heard on affidavits presented by the respective parties. The plaintiffs' affidavits show the land to be worth much less than \$2,000. The defendant's affidavits show that the land to it is worth largely more than \$2,000, the affiants putting its value to the railroad company at about \$5,000.

The question presented, then, is whether the value of the land to the defendant, as it is now being used in its present situation, should control, or whether its simple value as land apart from those considerations should control. I am satisfied that its value in its present situation to the defendant should be taken as the test of jurisdiction. Certainly more than \$2,000 in amount is involved, so far as the defendant is concerned. Its depot building alone, which is on this land, the affidavits show to be worth \$1,500. The case of *Railroad Co. v. Ward*, 2 Black, 485, 17 L. Ed. 311, which is largely quoted in subsequent cases, I think sustains this view. In *Smith v. Adams*, 130 U. S. 167, 9 Sup. Ct. 566, 32 L. Ed. 895, in the opinion, this language, pertinent here, is used:

"By 'matter in dispute' is meant the subject of litigation, the matter upon which the action is brought and issue is joined, and in relation to which, if the issue be one of fact, testimony is taken. It is conceded that the pecuniary value of the matter in dispute may be determined, not only by the money judgment prayed, where such is the case, but in some cases by the increased or diminished value of the property directly affected by the relief prayed, or

¶ 1. Jurisdiction of circuit courts as determined by the amount in controversy, see notes to *Auer v. Lombard*, 19 C. C. A. 75; *Shoe Co. v. Roper*, 36 C. C. A. 459.

by the pecuniary result to one of the parties immediately from the judgment."

It can hardly be denied that the pecuniary loss to the defendant company from a recovery by the plaintiffs in the action at bar would be more than \$2,000.

The necessary jurisdictional amount being involved, and this being the only question raised on the motion to remand, the motion is denied.

KING et al. v. SOUTHERN RY. CO.

(Circuit Court, N. D. Georgia, E. D. October 29, 1902.)

1. RAILROADS—APPROPRIATION OF LAND—RECOVERY BY SUBSEQUENT VENDEE.
Where a railroad company has entered into actual possession of land and erected a depot thereon, whether with or without the owner's consent, a subsequent vendee of the land from the owner cannot recover either the land or its value from the railroad company.

2. SAME—DECLARATION—DEMURRER.

Where, in an action to recover land, the abstract of title attached to the declaration showed that the conveyance to plaintiffs was made November 4, 1900, and it was alleged that defendant's railroad depot was located thereon, and that defendant had received the rents and profits from the land since August 1, 1897, the declaration showed on its face that the railroad company had been in actual occupancy of the land for depot purposes prior to the time when plaintiffs acquired title thereto, and was therefore demurrable.

J. E. Edwards, for plaintiffs.

Sanders McDaniel and J. J. Bowden, for defendant.

NEWMAN, District Judge. This is a suit by the plaintiffs to recover of the defendant railroad company a certain piece of land in Habersham county, Ga. After describing the land in their declaration, the plaintiffs say, "the Southern Railway Company's depot at Cornelia, Georgia, being located thereon." It is further alleged that "the Southern Railway Company has received the rents and profits from said land since the 1st day of August, 1897." The abstract of title attached to the declaration shows that the conveyance to the plaintiffs was made November 4, 1900.

It is well settled by the authorities that where a railroad company has entered into actual possession of land for railroad purposes, either with or without the owner's consent, a subsequent vendee cannot recover the land. The supreme court of the United States in *Roberts v. Railroad Co.*, 158 U. S. 1, 15 Sup. Ct. 756, 39 L. Ed. 873, holds this, quoting from the syllabus:

"When a railroad company, having the power of eminent domain, has entered into actual possession of lands necessary for its corporate purposes, whether with or without the consent of their owner, a subsequent vendee of the latter takes the land subject to the burden of the railroad; and the right to payment from the railroad company, if it entered by virtue of an agreement to pay, or to damages, if the entry was unauthorized, belongs to the owner at the time the railroad company took possession."

¶ 1. See *Eminent Domain*, vol. 18, Cent. Dig. § 408.

The supreme court of Georgia in *Green v. Railroad Co.*, 112 Ga. 849, 38 S. E. 81, discussing this question in the opinion, say:

"It is well settled that where a railroad company has entered into the actual possession of land, whether with or without the consent of the owner, by constructing and operating its line of road thereon, a subsequent purchaser of the land takes it subject to the burden of the railroad, and has no right of action against the company for the value of the land so appropriated."

—Citing, *McLendon v. Railroad Co.*, 54 Ga. 293; *Allen v. Railroad Co.*, 107 Ga. 838, 33 S. E. 696; *Roberts v. Railroad Co.*, supra.

The law being thus well settled, the only question is whether in this declaration, to which a demurrer is interposed, it is clearly shown that the railroad company entered into possession of this land prior to the conveyance to the plaintiffs. I think it does. Taking the two statements in the declaration together, that the depot of the Southern Railway Company at Cornelia is located on the land, and that it has received the rents and profits since 1897, no reasonable conclusion could be reached except that the railroad company has been occupying it for depot purposes since 1897. The land sought to be recovered is only one-fourth of an acre, and an ordinary railroad depot, with the usual platforms and appurtenances, would hardly occupy much less land than this. So it is reasonable to suppose that the land on which the depot is located, and such as is really appurtenant to, and immediately connected with, it, is what is sought to be recovered.

It is perfectly clear that the declaration fails to set forth a cause of action, and the demurrer is therefore sustained.

MEMORANDUM DECISIONS.

ADAIR v. ASKEY et al. (Circuit Court of Appeals, Fifth Circuit. January 13, 1903.) No. 1,142. Appeal from the Circuit Court of the United States for the Northern District of Texas. A. L. Matlock and F. E. Dycus, for appellant. John W. Wray, for appellees. Before PARDEE and SHELBY, Circuit Judges, and BOARMAN, District Judge.

PER CURIAM. We are of opinion that the bill in this case is without equity. The rights of fencing and inclosing land surrounding lands of another are regulated by the fifth section of an act of the legislature of the state of Texas passed February 7, 1884, reproduced in the Penal Code adopted in 1895 (page 95, c. 4, art. 509), and the complainant in this case did not comply therewith. We are also of opinion that the compromise between the parties, made since this appeal was sued out and exhibited in this court, covers all matters between the parties involved in this suit, except, perhaps, a claim for damages for past trespasses. For these reasons the decree of the circuit court is affirmed.

OHINA & JAPAN TRADING CO., Limited, v. DAVIS et al. (Circuit Court of Appeals, Fifth Circuit. February 10, 1903.) No. 1,192. In Error to the Circuit Court of the United States for the Eastern District of Texas. Before PARDEE and SHELBY, Circuit Judges, and BOARMAN, District Judge.

PER CURIAM. As no one of the judges who participated in the decision of this case desires a rehearing, and as all are satisfied with the decision as rendered, the petition for rehearing is denied.

EMSHEIMER v. CITY OF NEW ORLEANS. (Circuit Court of Appeals, Fifth Circuit. February 10, 1903.) No. 971. Appeal from the Circuit Court of the United States for the Eastern District of Louisiana. J. D. Rouse and William Grant, for appellant. Samuel L. Gilmore, City Atty., Frank B. Thomas, Asst. City Atty., and Branch K. Miller, for appellee. Before PARDEE, McCORMICK, and SHELBY, Circuit Judges.

PER CURIAM. The decree of the circuit court is affirmed. *Emsheimer v. City of New Orleans* (C. C.) 116 Fed. 893; *Id.*, 186 U. S. 33, 22 Sup. Ct. 770, 46 L. Ed. 1042.

PARDEE, Circuit Judge, dissents.

MILES et al. v. UNITED STATES. (Circuit Court of Appeals, Fifth Circuit. January 20, 1903.) No. 1,163. In Error to the Circuit Court of the United States for the Northern District of Georgia. R. T. Dorsey and Edwin H. Frazer, for plaintiffs in error. E. A. Angier, U. S. Atty., and George L. Bell, Asst. U. S. Atty. Before PARDEE, McCORMICK, and SHELBY, Circuit Judges.

PER CURIAM. The judgment of the circuit court is affirmed.

NASHVILLE, C. & ST. L. RY. CO. v. HOLLY. (Circuit Court of Appeals, Fifth Circuit. January 13, 1903.) No. 1,168. In Error to the Circuit Court of the United States for the Northern District of Alabama. Oscar R. Hundley, for plaintiff in error. James H. Ballentine, for defendant in error. Before PARDEE and SHELBY, Circuit Judges, and MEEK, District Judge.

PER CURIAM. After an examination of the record, and full consideration of the arguments at the bar and in briefs on file, we reach the conclusion that the judgment of the circuit court should be affirmed, and it is so ordered.

RUSH et al. v. BAILEY. (Circuit Court of Appeals, Fifth Circuit. January 13, 1903.) No. 1,203. Appeal from the Circuit Court of the United States for the Northern District of Mississippi. W. V. Sullivan and Murray F. Smith, for appellants. R. T. Fant and W. A. Percy, for appellee. Before PARDEE and SHELBY, Circuit Judges.

PER CURIAM. The Tate County Bank, by reason of having surrendered the delta lands in Mississippi and other property in Georgia, is not entitled to any part of the fund paid in by Eason in compromise of demands against Eason, Watkins & Co., because the record shows that the debt of Eason, Watkins & Co. to the Tate County Bank was paid in full, irrespective of the mortgaged property, and that, while the foreclosures of the deed of trust may have been regular in form, the proceeds of such foreclosures were not credited upon the debts or in any wise treated by the bank as payments, and the bank is not entitled to have its debt paid in full and still retain the mortgaged property. About March 6, 1896, Eason, besides paying the amount due the bank on the indebtedness above mentioned, also paid to Rush, attorney, and for the benefit of Day & Bailey, the sum of \$4,500, which sum was deposited in the Tate County Bank and has since remained there on deposit subject to call. The evidence does not show that there was any agreement on the part of the bank to pay interest on this deposit, nor that since the de-

posit the bank has specifically loaned or otherwise used the money for particular profit. It seems, therefore, that the bank should only be held for the \$4,500. By the original compromise authorized by Day & Bailey a sum of \$5,000 was to be paid for their account, on which Rush, attorney, was to have a fee of not exceeding 10 per cent. On account of the failure of Watkins to pay the sum of \$500, to be advanced under the terms agreed upon, the compromise covering all Eason, Watkins & Co.'s interests failed, and under a new arrangement Eason, instead of paying in \$5,000 for the account of Day & Bailey, in fact, and with the consent of Rush, only paid in the sum of \$4,500; and, so far as this record shows, all the funds actually received by Rush, attorney, for Day & Bailey, amounted to the sum of \$4,500. It is true that he afterwards refused a tender from Watkins of \$500, but this was so far proper under the facts of the case that Rush ought not to be charged therewith. The fact that he concealed the compromise as actually made from his principals, as well as the payment of the sums recovered, connected with his other conduct in the premises, deprives Rush of any right to a fee for his services and entitles his principals to recover the full amount collected by him. While there is no evidence that Rush used the money or was in any wise particularly advantaged by the same, under the facts disclosed he should pay interest, because of his unfaithful conduct as a trustee in the premises, and because through his conduct the fund has been unproductive. The legal rate of interest in the state of Mississippi is 6 per cent. per annum, but a maximum rate of 10 per cent. is allowed by convention. Rush not having used the fund, and the evidence showing no agreement to pay interest, the legal rate is all that should be charged. For these reasons, the decree of the circuit court is reversed, and it is adjudged and decreed that the Tate County Bank and Phil A. Rush in solido do pay to John W. Bailey, surviving partner, the sum of \$4,500, and, further, that the said Phil A. Rush do pay to said Bailey the additional sum of \$1,850.25, the interest on \$4,500 from March 6, 1896, to January 13, 1903, at 6 per cent. per annum, and that from and after this day above judgment shall bear 6 per cent. interest until paid. And it appearing that costs have been made in this court on certiorari and hearings thereon, and considering the general character of the case, it is further decreed that the costs of this court, including the cost of the transcripts, be divided between the appellants and the appellee, each to pay one-half, and that the costs of the circuit court be paid by Phil A. Rush. Execution may issue from the circuit court to enforce this decree for principal, interest, and all costs.

RUSH et al. v. BAILEY. (Circuit Court of Appeals, Fifth Circuit. February 10, 1903.) No. 1,203. Appeal from the Circuit Court of the United States for the Northern District of Mississippi. Before PARDEE and SHELBY, Circuit Judges.

PER CURIAM. As neither of the judges who participated in the decision of this case desires a rehearing, but each is still satisfied with the justice and equity of the decision as rendered, the application for rehearing is denied.

SULLIVAN et al. v. KING. (Circuit Court of Appeals, Fifth Circuit. February 3, 1903.) No. 1,207. Appeal from the Circuit Court of the United States for the Western District of Texas. C. L. Bates and J. C. Sullivan, for appellants. S. G. Newton and R. H. Ward, for appellee. Before PARDEE, MCCORMICK, and SHELBY, Circuit Judges.

PER CURIAM. This appeal is brought to review the proceedings in the bankruptcy court, where, on an issue of bankruptcy, a trial by jury was had, verdict rendered, and judgment entered thereon, and must be dismissed on the authority of Elliott & Co. et al., appellants, v. Ferdinand Toepfner, appellee (recently decided in the supreme court of the United States) 23 Sup. Ct. 133, 47 L. Ed. —. Decree accordingly.

TOWNSEND v. HUDSON et al. (Circuit Court of Appeals, Fifth Circuit. January 6, 1903.) No. 1,191. In Error to the Circuit Court of the United States for the Northern District of Texas. W. M. Walton and James H. Robertson, for plaintiff in error. M. B. Templeton, for defendants in error. Before PARDEE and SHELBY, Circuit Judges, and BOARMAN, District Judge.

PER CURIAM. We are all of opinion that the judgment of the circuit court is right, and it is therefore affirmed.

TROY WHITE GRANITE CO. v. LEHTOLA. (Circuit Court of Appeals, First Circuit. January 15, 1903.) No. 458. Charles C. Milton (Chandler Bullock, on the brief), for plaintiff in error. William A. Pew, Jr., for defendant in error. Before COLT and PUTNAM, Circuit Judges, and ALDRICH, District Judge.

PER CURIAM. The decree of the circuit court is affirmed, with costs for the defendant in error.

TYKESON v. SUPERIOR MFG. CO. et al. (Circuit Court of Appeals, First Circuit. January 15, 1903.) No. 440. Petition for Revision of Proceedings of the District Court of the United States for the District of Massachusetts, in bankruptcy. Harry J. Jaquith, for appellant. Charles Walcott and R. D. Weston-Smith, for appellee Superior Mfg. Co. Henry F. Hurlburt, Boyd B. Jones, and Frederick P. Cabot, for appellee Horace I. Pinkham. Before COLT and PUTNAM, Circuit Judges, and ALDRICH, District Judge.

PER CURIAM. Appeal dismissed, with costs for the appellees, under rule 23, par. 2, and mandate ordered to issue forthwith.

UNDERWOOD et al. v. MARSHALL WEDDINGTON et al. v. SAME. DICKSON et al. v. SAME. (Circuit Court of Appeals, Fifth Circuit. January 6, 1903.) Nos. 1,183-1,185. Appeals from the Circuit Court of the United States for the Northern District of Texas. John W. Wray (J. A. Luckey, on the brief), for appellants. W. P. McLean, for appellee. Before PARDEE and SHELBY, Circuit Judges, and BOARMAN, District Judge.

PER CURIAM. These three appeals were heard together. O. A. Marshall, a citizen of Missouri, filed a bill in equity in the lower court against G. B. Rowden, U. S. Weddington, W. L. Underwood, and Martha H. Dickson, citizens of Texas. The purpose of the bill was to foreclose two mortgages executed by the defendant Rowden to the Zeb F. Crider Commission Company to secure two promissory notes, one for \$5,202.50 and the other for \$5,644.50. Plaintiff became owner of the mortgages and notes. The mortgages embraced 198 head of three year old steers, 358 head of one year old steers, and 287 head of heifers. The defendant Rowden made no defense. W. L. Underwood, Martha H. Dickson, and U. S. Weddington filed separate answers, each claiming severally a part of the cattle embraced in the mortgages. The issue as to the claim made by each defendant was as to the priority and validity of the claim of the plaintiff under the mortgages to the property in question. Evidence was taken by the plaintiff and by each defendant, and the cause submitted to the court for decision. The circuit court sustained the claim of the plaintiff as against each defendant, rendering an elaborate and carefully prepared decree, in which the findings of fact and conclusions of law are fully stated. We have carefully examined the evidence found in the three records before us, and in our opinion it fully sustains the decree of the circuit court. A review or a condensed statement of the evidence would serve no useful purpose. It is sufficient to say that we fully approve the findings of fact and the conclusions of law relating to the claims of each one of the defendants, as stated in the final decree of the court from which these appeals are taken. The decree of the circuit court is affirmed.

UNITED STATES v. CARCABA et al. (Circuit Court of Appeals, Fifth Circuit. February 17, 1903.) No. 826. Appeal from the Circuit Court of the United States for the Southern District of Florida. J. Ward Gurley, for appellant. Before PARDEE, McCORMICK, and SHELBY, Circuit Judges.

PER CURIAM. On the authority of *Rothschild v. United States*, 179 U. S. 463, 21 Sup. Ct. 197, 45 L. Ed. 277, the judgment of the circuit court is reversed, and, so far as the decision of the board of general appraisers is objected to and protested against in this suit, the same is disapproved, and the decision of the collector assessing and imposing a duty of \$1.85 per pound on all leaf tobacco suitable for cigar wrappers, found or contained in the entry of P. F. Carcaba & Sons of imported tobaccos, is approved and confirmed; the appellees to pay the costs of the circuit court, and the costs of this appeal to be according to paragraph 4, rule 31 (31 C. C. A. clxix, 90 Fed. clxix).

UNITED STATES v. E. H. GATO CIGAR CO. (Circuit Court of Appeals, Fifth Circuit. February 17, 1903.) No. 825. Appeal from the Circuit Court of the United States for the Southern District of Florida. J. Ward Gurley, for appellant. Before PARDEE, McCORMICK, and SHELBY, Circuit Judges.

PER CURIAM. On the authority of *Rothschild v. United States*, 179 U. S. 463, 21 Sup. Ct. 197, 45 L. Ed. 277, the judgment of the circuit court is reversed, and, so far as the decision of the board of general appraisers is objected to and protested against in this suit, the same is disapproved, and the decision of the collector assessing and imposing a duty of \$1.85 per pound on all leaf tobacco suitable for cigar wrappers, found or contained in the entry of E. H. Gato Cigar Company of imported tobaccos, is approved and confirmed; the appellees to pay the costs of the circuit court, and the costs of this appeal to be according to paragraph 4, rule 31 (31 C. C. A. clxix, 90 Fed. clxix).

UNITED STATES v. PEREZ et al. (Circuit Court of Appeals, Fifth Circuit. February 17, 1903.) No. 827. Appeal from the Circuit Court of the United States for the Southern District of Florida. J. Ward Gurley, for appellant. Before PARDEE, McCORMICK, and SHELBY, Circuit Judges.

PER CURIAM. On the authority of *Rothschild v. United States*, 179 U. S. 463, 21 Sup. Ct. 197, 45 L. Ed. 277, the judgment of the circuit court is reversed, and, so far as the decision of the board of general appraisers is objected to and protested against in this suit, the same is disapproved, and the decision of the collector assessing and imposing a duty of \$1.85 per pound on all leaf tobacco suitable for cigar wrappers, found or contained in the entry of Perez & Co. of imported tobaccos, is approved and confirmed; the appellees to pay the costs of the circuit court, and the costs of this appeal to be according to paragraph 4, rule 31 (31 C. C. A. clxix, 90 Fed. clxix).

THE WILLIAM E. FERGUSON. THE LANGFOND. (Circuit Court of Appeals, Second Circuit. January 8, 1903.) Nos. 10, 11. Appeals from the District Court of the United States for the Eastern District of New York. Chas. T. Terry, for appellant. Le Roy S. Gove, for The Ferguson. F. M. Brown, for The Langfond. Before WALLACE, LACOMBE, and COXE, Circuit Judges. No opinion. Affirmed, on opinion of court below. 102 Fed. 699.

ENGELHORN v. UNITED STATES. (Circuit Court, S. D. New York. January 26, 1900.) No. 1,237. Appeal by the Importer from a Decision of the Board of United States General Appraisers, Which Affirmed a Decision by the Collector of Customs at the Port of New York. Albert Comstock, for appellant. Charles D. Baker, Asst. U. S. Atty.

TOWNSEND, District Judge (orally). The merchandise in question is terpin hydrate, assessed for duty under the provisions of paragraph 74, Tariff Act 1890, at 50 cents a pound, as a medicinal preparation of which alcohol is not a component part. The only evidence in the record to support the conclusion of the board that alcohol was used in the preparation of this medicinal preparation was the written statement of the examiner to that effect. The manufacturer stated under oath that no alcohol was used in its preparation: The uncontradicted evidence shows that alcohol is not necessarily or ordinarily thus used, and that this terpin hydrate was in no respect or degree different from the ordinary staple commercial terpin hydrate, in the preparation of which alcohol is used. In these circumstances, as it does not appear that there was any evidence that alcohol was used in the preparation of this medicinal preparation, or that the board could have ascertained that alcohol was so used from an inspection of the article, their decision is reversed.

FAYERWEATHER v. RITCH. REYNOLDS v. SAME. (Circuit Court, S. D. New York. October 7, 1902.) See (C. C.) 118 Fed. 943. Wm. Blaikie and Roger M. Sherman, for complainants. C. J. Bovee, Jr., for defendant.

LACOMBE, Circuit Judge. The appellate court may as well determine the question of costs, as well as the other questions which appeal will bring up. The decree will be entered without awarding costs or disbursements to any one. The form of decree submitted by the complainants and cross-complainants is adopted, with modification to eliminate provision as to costs, and the following additional changes: (1) Strike out the word "interlocutory," before "decree," when describing the proceedings in Re Hamilton College. It is thought that it is in fact an interlocutory decree, but it is unnecessary to characterize it. (2) Certain defendants, who are in the same position as Lincoln University, except that they did not move to set aside process, should now have process set aside as to them. When a form of decree, with these changes, is submitted, it will be signed.

UNITED STATES v. SCHERING et al. (Circuit Court, S. D. New York. November 11, 1902.) No. 3,191. Appeal by the United States from a decision of the Board of General Appraisers. Charles D. Baker, Asst. U. S. Atty. Albert Comstock, for importers.

TOWNSEND, Circuit Judge. This case involves salol, imported under the act of 1897 [U. S. Comp. St. 1901, p. 1626], and assessed for duty at 55 cents per pound, under paragraph 67 thereof [U. S. Comp. St. 1901, p. 1631], which provides for "medicinal preparations containing alcohol, or in the preparation of which alcohol is used, not specially provided for in this act, fifty-five cents per pound. * * *" The importers claim that they should pay but 25 per cent. ad valorem, under the provisions of paragraph 68 of said act [U. S. Comp. St. 1901, p. 1631], for medicinal preparations not containing alcohol or in the preparation of which alcohol is not used. The decision of the board of appraisers is affirmed, on the authority of suit No. 3,141 (The United States v. Schering & Glatz, 119 Fed. 473).

INDEX.

ABANDONMENT.

Of copyright, see "Copyright," § 1.
Of insured vessel, see "Insurance," § 4.

ABATEMENT AND REVIVAL.

Election of remedy, see "Election of Remedies."
Judgment as bar to another action, see "Judgment," § 3.

ABUTTING OWNERS.

Compensation for taking of or injury to lands or easements for public use, see "Eminent Domain," § 1.

ACCEPTANCE.

Of offer to sell, see "Sales," § 1.

ACCESSION.

Annexation of personal to real property, see "Fixtures."

ACCIDENT.

Accident insurance, see "Insurance," § 3.
Cause of death, see "Death," § 1.

ACCOMMODATION PAPER.

See "Bills and Notes."

ACCOUNT.

Examination of account as ground for appointment of auditor, see "Reference," § 1.

ACCRETION.

See "Navigable Waters," § 2.

ACTION.

Bar by former adjudication, see "Judgment," § 3.
Counterclaim, see "Set-Off and Counterclaim."
Election of remedy, see "Election of Remedies."
Jurisdiction of courts, see "Courts."
Limitation by statutes, see "Limitation of Actions."

Review of proceedings, see "Appeal and Error"; "Equity," § 6; "New Trial."
Set-off, see "Set-Off and Counterclaim."

Actions between parties in particular relations.

See "Master and Servant," § 1.

Co-tenants, see "Partition," § 1.

Actions by or against particular classes of parties.

See "Carriers," § 1.

Assignees, see "Assignments," § 1.

Bailees, see "Bailment."

Bankrupts, see "Bankruptcy," § 7.

Foreign corporations, see "Corporations," § 7.

Stockholders, see "Banks and Banking," § 1;

"Corporations," § 2.

Trustees, see "Trusts," § 1.

Particular causes or grounds of action.

See "Bills and Notes," § 3; "Collision," § 9;

"Customs Duties," § 4; "Death," § 1;

"Fraud," § 2; "Insurance," §§ 6, 7; "Libel

and Slander," § 1; "Negligence," § 2.

Breach of contract, see "Sales," § 3.

County bonds, see "Counties," § 1.

Infringement of copyright, see "Copyrights,"

§ 2.

Infringement of patent, see "Patents," § 6.

Particular causes or grounds of action, see

"Trespass."

Personal injuries, see "Master and Servant,"

§ 1; "Railroads," § 2.

Price of goods, see "Sales," § 2.

Recovery of price paid for land, see "Vendor

and Purchaser," § 1.

Taking of or injury to property in exercise of

power of eminent domain, see "Eminent Domain," § 2.

Particular forms of action.

See "Ejectment."

Particular forms of special relief.

See "Creditors' Suit"; "Injunction"; "Parti-

tion," § 1; "Specific Performance."

Dissolution of corporation, see "Corporations,"

§ 6.

Enforcement or foreclosure of lien, see "Me-

chanics' Liens," § 2.

Establishment and enforcement of trust, see

"Trusts," § 1.

Foreclosure of chattel mortgage, see "Chattel

Mortgages," § 1.

Foreclosure of mortgage, see "Mortgages," § 2.

Particular proceedings in actions.

See "Costs"; "Damages"; "Evidence"; "Judg-

ment"; "Limitation of Actions"; "Parties";

"Pleading"; "Reference"; "Removal of Causes";

"Stipulations"; "Trial."

Particular remedies in or incident to actions.

See "Attachment"; "Discovery"; "Injunction"; "Receivers."

Proceedings in exercise of special jurisdictions.

Suits in admiralty, see "Admiralty"; "Collision," § 9.

Suits in equity, see "Equity."

ACTS OF BANKRUPTCY.

See "Bankruptcy," § 1.

ADEQUATE REMEDY AT LAW.

Effect on jurisdiction of equity, see "Equity," § 1.

ADJOINING LANDOWNERS.

See "Boundaries."

ADJUDICATION.

Following decisions of state courts as to construction of statutes, see "Courts," § 7.

Of courts in general, see "Courts," § 1.

Operation and effect of former adjudication, see "Judgment," § 3.

ADMINISTRATION.

Of estate of bankrupt, see "Bankruptcy," § 5.

Of property by receiver, see "Receivers," § 3.

ADMIRALTY.

See "Collision"; "Maritime Liens"; "Salvage"; "Seamen"; "Shipping"; "Towage."

§ 1. Parties, process, claims, and stipulations or other security.

The principle of admiralty rule 59 will be applied by analogy to other than collision cases, by permitting the bringing in of any additional defendant who may be liable in whole or in part for the claim sued on.—Dailey v. City of New York (D. C.) 1005.

§ 2. Pleading, petitions, and motions.

A master of a vessel, as libellant, cannot recover damages for loss to the owners from the cancellation of a charter party, where the libel does not claim damages therefor, or mention the charter party.—Harrison v. Hughes (D. C.) 997.

§ 3. Decree and enforcement thereof.

Where libel by master of a vessel does not claim damages for loss to owners from cancellation of charter party, the court may allow an amendment of the interlocutory decree, and refer the case to a commissioner to deal with the subject-matter of the amendment.—Harrison v. Hughes (D. C.) 997.

ADVERSE POSSESSION.**§ 1. Operation and effect.**

Possession of land by the grantee in a deed which described the land by metes and bounds

held not to extend to other land, outside of such boundary, which the deed purported to convey as an accretion, as against the owner of the legal title to such claimed accretion.—Stockley v. Cissna (C. C. A.) 812.

§ 2. Pleading, evidence, trial, and review.

A deed raises no presumption that an actual possession of the land which the grantee is shown to have held at a later date commenced at the date of its delivery.—Stockley v. Cissna (C. C. A.) 812.

AFFREIGHTMENT.

Contracts, see "Shipping," § 2.

AGREEMENT.

See "Contracts."

ALIENS.

See "Indians."

ALLOWANCE.

To widow of bankrupt, see "Bankruptcy," § 7.

ALTERATION OF INSTRUMENTS.

A lessor held to have waived an alteration in an oil lease made by the lessee after its execution by his failure to object and his insistence on its performance after knowledge of such alteration.—Barnsdall v. Boley (C. C.) 191.

AMENDMENT.*Of particular legal proceedings.*

Of interlocutory judgment in admiralty, see "Admiralty," § 3.

Of pleading, see "Equity," § 2; "Pleading," § 2.

AMOUNT IN CONTROVERSY.

Jurisdictional amount, see "Courts," § 5; "Removal of Causes," § 5.

ANCILLARY RECEIVERSHIP.

For foreign corporation, see "Corporations," § 7.

ANSWER.

In pleading, see "Equity," § 2.

APPEAL AND ERROR.

See "New Trial."

Review in bankruptcy proceedings, see "Bankruptcy," § 8.

Right of review of finding dependent on whether of fact or law, see "Trial," § 3.

§ 1. Decisions reviewable.

An order dismissing the petition of a receiver for the settlement of his accounts after the

property had been sold and the proceeds distributed, and asking that the deficiency remaining due on the expenses of the receivership be adjudged against the complainant, is a final order, from which the receiver is entitled to appeal.—Chapman v. Atlantic Trust Co. (C. C. A.) 257.

§ 2. Parties.

Facts held to show portion of defendants, against all of whom joint judgment had been rendered, were parties to writ of error.—Fitzpatrick v. Graham (C. C. A.) 353.

To give the circuit court of appeals jurisdiction to review a joint judgment against all the defendants in ejectment, it is necessary that all join in the writ.—Fitzpatrick v. Graham (C. C. A.) 353.

§ 3. Requisites and proceedings for transfer of cause.

An appeal bond taken under Rev. St. §§ 1000, 1012 [U. S. Comp. St. 1901, pp. 712, 716], on an appeal, may, under section 1000 [page 712], be approved by any judge or justice authorized to sign the citation and to allow the writ of error or appeal.—Brown v. Northwestern Mut. Life Ins. Co. (C. C. A.) 148.

§ 4. Record and proceedings not in record.

A judgment will not be reversed on appeal because of the refusal of instructions requested, where the record does not contain the entire charge given.—Northern Pac. Ry. Co. v. Tynan (C. C. A.) 288.

§ 5. Dismissal, withdrawal, or abandonment.

An appeal from an interlocutory decree finding infringement of a patent presents for review only that part of the decree granting an injunction, and will be dismissed where it is shown that the controversy between the parties in respect to the injunction has been settled.—Thomson-Houston Electric Co. v. Nassau Electric R. Co. (C. C. A.) 354.

§ 6. Review.

It is only when it appears so clear as to be beyond doubt that the error complained of did not prejudice the complainant that the rule that error without prejudice is no ground for reversal is applicable.—United States v. Gentry (C. C. A.) 70.

Where the action of a trial court in a certain respect was specifically assigned as error in the appellate court, and was approved, at least by implication, the trial court is justified in following the same course on a second trial; and its action in so doing will not be again reviewed on a second appeal.—Olsen v. North Pacific Lumber Co. (C. C. A.) 77.

Where the validity of an order appointing a receiver was not attacked on a prior appeal, it cannot be litigated on a subsequent appeal.—Clark v. Brown (C. C. A.) 130.

A special finding which states the ultimate facts is conclusive upon the appellate court, even though it contains, in addition, statements of evidence and inferences therefrom.—American Nat. Bank v. Watkins (C. C. A.) 545.

A judgment will not be reversed for technical errors in rulings on the admission of evidence which were not prejudicial.—American Nat. Bank v. Watkins (C. C. A.) 545.

On an assignment of error for admitting the answer of a witness claimed to have been incompetent, where the answer is susceptible of two constructions, one of which renders it competent, it will be given such construction in support of the ruling, as error must affirmatively appear.—Supreme Council American Legion of Honor v. Orcutt (C. C. A.) 682.

The action of the court in not insisting that a verdict should contain a statement as to what amount was actual and what exemplary damages held harmless to defendant.—Friedly v. Giddings (C. C.) 438.

An instruction held harmless as on an immaterial issue.—Friedly v. Giddings (C. C.) 438.

Where the trial court did not err in refusing to direct a verdict for defendant, the verdict of the jury will not be disturbed on appeal.—Hawes v. Warren (C. C.) 978.

§ 7. Determination and disposition of cause.

When it is manifest that a plaintiff is entitled to recover damages, and the amount awarded him is as small as it can be reasonably expected would be given by another jury, the judgment will not be reversed because of technical errors in procedure on the trial.—City of Chicago v. Le Moyne (C. C. A.) 662.

Where the appellate court is satisfied that the jury acted honestly and considerately, a verdict for excessive damages does not necessitate a reversal, if the damages be remitted.—Hawes v. Warren (C. C.) 978.

§ 8. Liabilities on bonds and undertakings.

The obligee in a bond which supersedes an order affirming a sale of real estate, and directs the execution of a deed, and delivery of possession to the purchaser, is entitled, after affirmation on appeal, to recover as damages the value of the use and possession.—Brown v. Northwestern Mut. Life Ins. Co. (C. C. A.) 148.

APPLIANCES.

Liability of employer for defects, see "Master and Servant," § 1.

APPLICATION.

For discharge in bankruptcy, see "Bankruptcy," § 7.

APPOINTMENT.

Of receiver, see "Receivers," § 1.
Of trustee in bankruptcy, see "Bankruptcy," § 2.

APPROVAL.

Of appeal bond, see "Appeal and Error," § 3.

ARBITRATION AND AWARD.

See "Reference."

§ 1. Submission.

Provision in a bill of sale for arbitration held not to make an award of arbitrators a condition precedent to a right of action.—*Dickson Mfg. Co. v. American Locomotive Co.* (C. C.) 488.

An agreement for arbitration held not irrevocable.—*Dickson Mfg. Co. v. American Locomotive Co.* (C. C.) 488.

ARGUMENT OF COUNSEL.

See "Trial," § 1.

ARMY AND NAVY.

Arrest of army officer acting under federal laws on warrant of state court, see "States," § 1.
Injunction affecting army officer, see "Injunction."

ARREST.

Of army officer acting under federal laws on warrant from state court, see "States," § 1.

ASSESSMENT.

Of damages, see "Damages," § 2.
Of loss on insured, see "Insurance," § 7.

ASSIGNMENTS.

Of mortgages, see "Mortgages," § 1.

§ 1. Actions.

An agreement by the assignee of a contract, by which he assumes the obligations of his assignor thereunder, does not make him a party to the contract, so that he may be sued thereon at law by the other party; nor can such an action be maintained upon the doctrine of subrogation, which pertains to equity only.—*Good-year Shoe Machinery Co. v. Dancel* (C. C. A.) 692.

ASSIGNMENTS FOR BENEFIT OF CREDITORS.

See "Bankruptcy."

ASSOCIATIONS.

See "Building and Loan Associations."
Mutual benefit insurance associations, see "Insurance," §§ 4, 7.

ASSUMPTION.

Of risk by employé, see "Master and Servant," § 1.

ATTACHMENT.

§ 1. Claims by third persons.

Under the Mississippi Code, which governs in a federal court in that state, where a third

party files the required affidavit of claim to attached property on the return of the attachment, plaintiff must cause an issue to try the right of property to be made up at the same term, and, if he does not, the claimant is entitled to have the property discharged.—*Miller v. Tennant-Stribling Shoe Co.* (C. C. A.) 865.

§ 2. Liabilities on bonds or undertakings.

Surety on attachment bond held not liable for proceeds of sale of property erroneously paid to attaching plaintiff under order of the court, *Rev. St. U. S. §§ 995, 996* [U. S. Comp. St. 1901, p. 711].—*Files v. Davis* (C. C.) 1002.

ATTORNEY AND CLIENT.

Argument and conduct of counsel at trial in civil actions, see "Trial," § 1.

BAILMENT.

See "Carriers," § 1.

A railroad company has such property in cars which it holds under lease, and in cars of other companies temporarily in its possession and use as bailee, as will support an action for their wrongful injury or destruction.—*City of Chicago v. Pennsylvania Co.* (C. C. A.) 497.

BANKRUPTCY.

§ 1. Petition, adjudication, warrant, and custody of property.

Under *Bankr. Act*, § 3, cl. 3 [U. S. Comp. St. 1901, p. 3422], where an insolvent corporation fails to cause a preference by legal proceedings obtained by one creditor to be discharged, it commits an act of bankruptcy.—*White v. Bradley Timber Co.* (D. C.) 989.

Obtaining the appointment of a receiver by an insolvent partnership through dissolution proceedings in a state court, though such action was taken for the purpose of preventing the bankruptcy court from obtaining possession of the assets, is not an act of bankruptcy, under *Bankr. Act* 1898, § 3a, cl. 1 [U. S. Comp. St. 1901, p. 3422].—*In re Varick Bank* (D. C.) 991.

§ 2. Assignment, administration, and distribution of bankrupt's estate.—Appointment, qualification, and tenure of trustee.

Under *Bankr. Act*, § 1, subd. 16, and *Id.* c. 5, § 44 [U. S. Comp. St. 1901, pp. 3419, 3438], and *General Order* 13 (32 C. C. A. xvii, 89 Fed. vii), a referee could not ignore the appointment of a trustee by creditors, and appoint another, but, if he disapproved, it was his duty to make an order in writing, and on this the parties had a right to be heard before the judge.—*In re Hare* (D. C.) 246.

Bankr. Act, § 2, subd. 17 [U. S. Comp. St. 1901, p. 3421], confers no power on a referee to appoint a trustee in bankruptcy in disregard of an appointment by creditors, under *Bankr. Act*, § 1, subd. 16, and *Id.* c. 5, § 44 [U. S. Comp. St. 1901, pp. 3419, 3438], and *General Order* 13 (32 C. C. A. xvii, 89 Fed. vii).—*In re Hare* (D. C.) 246.

If the failure of a referee in bankruptcy proceedings to approve an appointment of a trustee made by creditors under Bankr. Act, § 1, subd. 16, and Id. c. 5, § 44 [U. S. Comp. St. 1901, pp. 3419, 3438], and General Order 13 (32 C. O. A. xvii, 89 Fed. vii), created a vacancy, still the court or referee had no authority to appoint another until a full opportunity was given to the creditors.—In re Hare (D. C.) 246.

§ 3. — Assignment, and title, rights, and remedies of trustee in general.

Where, prior to the adjudicated bankruptcy of a judgment debtor, possession of property was acquired by a levy under an execution issued out of a state court, the referee could not enjoin further proceedings to enforce the judgment.—White v. Thompson (C. C. A.) 868.

A bank, which received money on deposit, to be prorated between the creditors of a partnership, holds the same in a fiduciary capacity, and cannot assert an adverse claim thereto after the partnership has been adjudged bankrupt.—In re Davis (D. C.) 950.

The trustee of a bankrupt has no equitable standing to enjoin the removal from a building of a steam engine which the bankrupt had not paid for, nor acquired the legal title to, without an offer to pay to the owner the unpaid purchase price.—In re Smith (D. C.) 1004.

§ 4. — Preferences and transfers by bankrupt, and attachments and other liens.

Where the bankrupt court has jurisdiction of the res to which conflicting liens attach, it has jurisdiction to determine the priorities of such liens, though the trustee has no interest in such question.—Chauncey v. Dyke Bros. (C. C. A.) 1.

A chattel mortgage by a merchant on stock, he retaining possession and paying expenses and debts, held within Bankr. Act 1898, § 67e [U. S. Comp. St. 1901, p. 3449], and void as against creditors on his being adjudged bankrupt within four months thereafter.—Egan State Bank v. Rice (C. C. A.) 107.

The return by a bankrupt to a bank of money borrowed under an express agreement that it should be used only for a particular purpose, but which was not so used, did not constitute a preference affecting other claims of the bank against the estate in bankruptcy.—Dressel v. North State Lumber Co. (D. C.) 531.

A payment received by a creditor of a bankrupt from a third party, and which did not come out of the assets of the bankrupt, does not constitute a preference.—Dressel v. North State Lumber Co. (D. C.) 531.

§ 5. — Administration of estate.

An agreement between lienholders, on property of which a trustee in bankruptcy held the legal title, to submit the priority of their liens to the referee, held to give him jurisdiction of the res to which the lien related.—Chauncey v. Dyke Bros. (C. C. A.) 1.

Mechanic's lien creditors of a bankrupt held entitled, under an order directing the sale of property as an entirety, including that covered

by their liens, to assert their rights to a preference against the fund produced by the sale.—George Carroll & Bro. Co. v. Young (C. O. A.) 576.

Under general orders in bankruptcy No. 37, held the duty of a referee in bankruptcy to take down all excluded testimony and make the same a part of the record.—In re Lipset (D. C.) 379.

A trustee held not entitled to the advice and direction of the court as to whether he should proceed against a secured creditor for fraudulently proving his claim as unsecured and receiving dividends thereon.—In re Baber (D. C.) 520.

On an application of a trustee in bankruptcy to the court for advice as to whether he should file a petition to have the claim of a creditor expunged for fraud, the referee has no authority to hear and determine the subject-matter of such petition on the merits.—In re Baber (D. C.) 520.

The right of trustees to apply for the direction of the court as to the discharge of their duties discussed.—In re Baber (D. C.) 520.

Exceptions taken before a referee in bankruptcy must be specific, as required by the settled practice of the federal courts.—Dressel v. North State Lumber Co. (D. C.) 531.

A referee in bankruptcy is governed by the rules in equity in taking testimony, and is not authorized to excuse a witness from answering questions on objection thereto.—Dressel v. North State Lumber Co. (D. C.) 531.

A special allowance to a referee for services performed, in addition to the fees fixed by the bankruptcy act, cannot be made, even with the consent of the attorneys for the parties in interest.—Dressel v. North State Lumber Co. (D. C.) 531.

A summary order, made by a court of bankruptcy, requiring a third party to pay over to a trustee money of an estate in his possession, should not include interest on the amount withheld.—In re Davis (D. C.) 950.

A court of bankruptcy has jurisdiction to require money in the hands of a third party belonging to an estate to be paid over to the trustee by a summary order, where no adverse claim thereto was asserted by the party in possession at the time of the filing of the petition in bankruptcy.—In re Davis (D. C.) 950.

A federal district court, sitting as a court of bankruptcy, has jurisdiction to proceed against a bankrupt for contempt, where he has failed to turn over all of his property to the trustee.—In re Shachter (D. C.) 1010.

On a rule against a bankrupt for contempt, evidence held to justify a finding that he was possessed of goods of the value of \$1,063.94, which he had not surrendered to the trustee.—In re Shachter (D. C.) 1010.

§ 6. Claims against and distribution of estate.

The adjudication in bankruptcy of a lessee does not operate in itself to terminate his lease and end his estate so as to give a sublessee a

claim for damages which can be proved as a debt against his estate.—In re Pennewell (C. C. A.) 139.

A lessee cannot prove a claim for damages for breach of a covenant for quiet enjoyment in a lease against the estate of his lessor in bankruptcy because of his eviction after the filing of the petition in bankruptcy.—In re Pennewell (C. C. A.) 139.

The facts that the cashier of a national bank was prosecuted and convicted of a misapplication of the bank's funds in discounting a large amount of comparatively worthless notes for a customer, and that the bank's receiver sued for and recovered the penalty in the cashier's bond, do not affect the validity of the notes nor the bank's ownership thereof; and the receiver may prove the same in bankruptcy against the estate of an indorser.—In re Edson (D. C.) 487.

Only creditors of a bankrupt whose claims are allowed have any standing to contest the claims of others.—Dressel v. North State Lumber Co. (D. C.) 531.

§ 7. Rights, remedies, and discharge of bankrupt.

A bankrupt may claim his exemptions, allowed by the laws of Georgia, from the proceeds of property which he had assigned for the benefit of creditors, but which, after the bankruptcy, was turned over to his trustee as a part of his estate.—Bashinski v. Talbott (C. C. A.) 337.

A bankrupt held properly refused a discharge on the ground that he knowingly and fraudulently concealed property from his trustee in failing to schedule land the title to which stood in the name of his son, but which was acquired with money of the bankrupt and occupied by him under such circumstances as to establish the fact that the son held the title in trust for him.—Hudson v. Mercantile Nat. Bank (C. C. A.) 346.

The property and allowances awarded a widow by Rev. St. Ohio, §§ 6038-6040, are in lieu of the exemptions the husband in bankruptcy proceedings would be entitled to from the bankrupt estate in case he had lived.—In re Parschen (C. C.) 976.

Under Bankr. Act 1898, § 8 [U. S. Comp. St. 1901, p. 3425], a widow of a bankrupt residing in Ohio held entitled to the articles enumerated in Rev. St. Ohio, §§ 6038, 6039, or, in their absence, their equivalent in money, and the allowances for support provided by section 6040.—In re Parschen (C. C.) 976.

Under Bankr. Act 1898, § 8 [U. S. Comp. St. 1901, p. 3425], a widow of a bankrupt residing in Ohio held entitled to reside a year in the mansion house of her deceased husband, if dower is not sooner assigned, as provided by Rev. St. Ohio, § 4188.—In re Parschen (C. C.) 976.

An unexplained shrinkage of \$12,000 in the estate of an insolvent prior to the filing of his petition in bankruptcy, held of itself not sufficient proof of a fraudulent concealment of property.—In re Leslie (D. C.) 406.

If a bankrupt willfully and fraudulently conceals any of his property from the trustee, he is

not entitled to a discharge.—In re Leslie (D. C.) 406.

Under Bankr. Act, § 7a, subds. 1, 9 [U. S. Comp. St. 1901, pp. 3424, 3425], testimony given by a bankrupt at creditors' meetings and showing a fraudulent concealment of property by him, held admissible to defeat his application for a discharge.—In re Leslie (D. C.) 406.

In an application for the discharge of a bankrupt, the burden of showing that certain money was paid by him to the trustee held to be on the bankrupt.—In re Leslie (D. C.) 406.

Evidence in an application for the discharge of a bankrupt examined, and held to show that certain money, received by him after the filing of the petition, had not been paid to the trustee.—In re Leslie (D. C.) 406.

While evasive and disingenuous testimony by a bankrupt is not a ground for refusing a discharge, it is a material consideration in determining his credibility, when testifying as to what became of certain money.—In re Leslie (D. C.) 406.

A fair preponderance of the credible evidence is all that is needed to show a fraudulent concealment of property by a bankrupt, so as to defeat his discharge.—In re Leslie (D. C.) 406.

Creditors of an insolvent New Jersey corporation, claiming causes of action against stockholders by virtue of Laws N. J. 1896, c. 185, §§ 21, 48, 49, held entitled to reduce their claims against the corporation to judgments.—In re Remington Automobile & Motor Co. (D. C.) 441.

Specifications opposing a bankrupt's discharge held amendable at the discretion of the court.—In re Glass (D. C.) 509.

Specifications opposing a petition for a bankrupt's discharge must be signed and sworn to by the opposing creditor or creditors, and not by attorney or counsel.—In re Glass (D. C.) 509.

Form of verification of specifications opposing a bankrupt's discharge prescribed.—In re Glass (D. C.) 509.

Form of signature of specifications opposing a bankrupt's discharge, by a corporation, prescribed.—In re Glass (D. C.) 509.

Any member of a firm opposing a bankrupt's discharge held entitled to sign and verify the specifications.—In re Glass (D. C.) 509.

Attorneys or agents held not entitled to verify specifications opposing a bankrupt's discharge, in the absence of a previous order therefor.—In re Glass (D. C.) 509.

Facts concerning concealment of assets held to show such fraud in bankrupt as to require revocation of discharge.—In re Roosa (D. C.) 542.

A bankrupt cannot be refused a discharge because of a failure to schedule land which he conveyed long prior to the passage of the bankruptcy act, unless it is clearly shown that he actually owned it, or an interest therein, at the time of the bankruptcy.—In re Countryman (D. C.) 639.

Objection that evidence offered on the trial of specifications of objection to a bankrupt's discharge is not within the issues must be made before or during the trial before the referee, or it is waived.—*In re Baldwin* (D. C.) 796.

It is the settled practice in the Northern district of New York to require all objections to the sufficiency of specifications of objection to the discharge of a bankrupt to be raised before the judge on motion within a specified time.—*In re Baldwin* (D. C.) 796.

Amounts paid out by a trustee in bankruptcy, otherwise than in the manner prescribed by the orders in bankruptcy and the rules of court, will not be allowed in the settlement of the estate.—*In re Hoyt* (D. C.) 987.

§ 8. Appeal and revision of proceedings.
An appeal in bankruptcy court from a judgment in regard to exemptions *held best settled* by an order leaving the question in the probate court, from which it should not have been taken.—*White v. Thompson* (C. C. A.) 868.

BANKS AND BANKING.

Taxation of national bank shares, see "Taxation."

§ 1. National banks.
Specific authority given by the comptroller to the receiver of a national bank to bring an action against a stockholder to recover an assessment is not withdrawn or affected by a subsequent general authority to compromise or sell all the claims or assets of the bank.—*McClaine v. Rankin* (C. C. A.) 110.

The testimony of a witness that in his capacity as receiver of a national bank he made personal demand upon a stockholder for the payment of an assessment, and that the stockholder admitted having received notice thereof, where uncontradicted, sufficiently shows notice and demand to support an action to recover the assessment.—*McClaine v. Rankin* (C. C. A.) 110.

A complaint in an action by the receiver of a national bank against a stockholder to recover an assessment *held sufficient*.—*McClaine v. Rankin* (C. C. A.) 110.

BAR.

Of action by former adjudication, see "Judgment," § 3.

BENEFICIAL ASSOCIATIONS.

Building or loan associations, see "Building and Loan Associations."
Mutual benefit insurance associations, see "Insurance," §§ 4, 7.

BEST AND SECONDARY EVIDENCE.

In civil actions, see "Evidence," § 3.

BILL OF DISCOVERY.

See "Discovery," § 1.

BILL OF REVIEW.

See "Equity," § 6.

BILLS AND NOTES.

§ 1. Requisites and validity.

Notes given by defendant *held to have been* in consideration of the agreement of the payee to convey to him certain real estate and securities, so that the loss of title by the payee through its own acts constituted a failure of consideration.—*American Nat. Bank v. Watkins* (C. C. A.) 545.

§ 2. Rights and liabilities on indorsement or transfer.

An accommodation indorser of a note, made payable to the order of the maker and indorsed by him, is entitled to demand and notice of non-payment before his liability becomes fixed.—*In re Edson* (D. C.) 487.

§ 3. Actions.

Under the modern American rule, a partial failure of consideration may be pleaded as a defense in an action at law on a note.—*American Nat. Bank v. Watkins* (C. C. A.) 545.

BONDED WAREHOUSES.

See "Internal Revenue."

BONDS.

County bonds, see "Counties," § 1.
Municipal bonds, see "Municipal Corporations," § 2.

Bonds in legal proceedings.

See "Appeal and Error," §§ 3, 8; "Attachment," § 2.

BOUNDARIES.

Of mining claims, see "Mines and Minerals," § 1.
Of states, see "States," § 1.

§ 1. Description.

Where by the law of the state, as in Tennessee, lands bounded by a navigable river extend only to ordinary low-water mark, the title to the bed of the stream remaining in the state, the sudden abandonment of the channel by the river, by the cutting of a new channel, does not extend the boundaries of adjoining owners, but the dry land so made still belongs to the state.—*Stockley v. Cissna* (C. C. A.) 812.

BUILDING AND LOAN ASSOCIATIONS.

The issuance by a building and loan association of a class of shares not at the time authorized by the by-laws is validated by a subsequent amendment authorizing the same and ratifying those previously issued.—*Wilson v. Parvin* (C. C. A.) 652.

A building and loan association of Tennessee *held to have power*, under its by-laws and the laws of the state, to issue paid-up shares, preferred both as to dividends and principal, and secured by a pledge of securities in trust; and

the holders of such shares *held* entitled to enforce the preference, after the insolvency of the association, as between the shareholders.—*Wilson v. Parvin* (C. C. A.) 652.

A building and loan association, in the absence of charter or other legal inhibition in the law of the state of its origin, may lawfully give one class of shares preference over another, both with respect to dividends and principal.—*Wilson v. Parvin* (C. C. A.) 652.

Holders of paid-up stock of a building and loan association, although entitled by the contract to preference in payment of both principal and dividends, such dividends, however, to be payable only out of the profits, are not entitled to interest on their shares after the association has become insolvent and ceased to make any profits.—*Wilson v. Parvin* (C. C. A.) 652.

CANCELLATION OF INSTRUMENTS.

Cancellation of corporate stock, see "Corporations," § 1.

Rescission of contract, see "Contracts," § 3.

CARGO.

See "Shipping."

CARRIERS.

Carriage of goods by vessels, see "Shipping," § 2.

§ 1. Carriage of goods.

An intermediate carrier of goods is bound only to use reasonable diligence to secure further transportation, and if, when tendered to the connecting carrier, they are refused, to notify the shipper. Having done this, and stored or otherwise cared for the goods, its liability as carrier ceases, and liability as warehouseman is substituted.—*Buston v. Pennsylvania R. Co.* (C. C. A.) 808.

A railroad company, having tendered cotton to a connecting carrier, by whom it was refused because deemed in a dangerous condition, and having notified the owner, was justified in storing the cotton subject to the owner's order, and is not liable for a failure to place it in condition and then tender it again.—*Buston v. Pennsylvania R. Co.* (C. C. A.) 808.

CERTIFICATE.

Certified copies, see "Evidence," § 5.

Of corporate stock, see "Corporations," § 1.

Of location of mining claims, see "Mines and Minerals," § 1.

CHAMPERTY AND MAINTENANCE.

Affecting right to maintain suit, see "Parties," § 1.

Effect of champerty on right to specific performance of contract, see "Specific Performance," § 2.

CHANCERY.

See "Equity."

CHARGE.

To jury in civil actions, see "Trial," § 2.

CHARTER PARTIES.

See "Shipping," § 1.

CHATTEL MORTGAGES.

By bankrupt as preference, see "Bankruptcy," § 4.

§ 1. Foreclosure.

A federal court of equity is not without jurisdiction of a suit to foreclose a chattel mortgage because the mortgagee had the right under the state statute to take possession of and sell the property on condition broken.—*H. B. Claffin Co. v. Furtick* (C. C.) 429.

Where a chattel mortgage securing a single debt is taken to a third person named as a trustee, he is merely an agent of the creditor, and the latter may maintain a suit to foreclose in his own name.—*H. B. Claffin Co. v. Furtick* (C. C.) 429.

A federal court of equity has power, in the exercise of its discretion, to take the property covered by a chattel mortgage into its custody, in a suit to foreclose by its marshal or a receiver, on a preliminary application therefor by complainant and without notice to defendant.—*H. B. Claffin Co. v. Furtick* (C. C.) 429.

Complainant in a suit to foreclose a chattel mortgage on a stock of goods *held* entitled to the appointment of a receiver on the showing made and under the provisions of the mortgage.—*H. B. Claffin Co. v. Furtick* (C. C.) 429.

CHEAT.

See "Fraud."

CHINESE.

Validity of act for segregation of Chinese children in separate schools as denial of equal protection of laws, see "Constitutional Law," § 2.

CHOSE IN ACTION.

Assignment, see "Assignments."

CIRCUIT COURTS OF APPEALS.

See "Courts," § 8.

CITIES.

See "Municipal Corporations."

CITIZENS.

See "Indians."

Citizenship ground of jurisdiction of United States courts, see "Courts," § 4; "Removal of Causes," § 3.

Equal protection of laws, see "Constitutional Law," § 2.

CIVIL RIGHTS.

See "Constitutional Law," § 2.

CLAIMS.

Against estate of bankrupt, see "Bankruptcy," § 6.
Mining claims, see "Mines and Minerals," § 1.
Of patent, see "Patents," § 4.
To property levied on, see "Attachment," § 1.

COLLATERAL ATTACK.

On judgment, see "Judgment," § 2.

COLLECTION.

Of assets of bankrupt, see "Bankruptcy," § 5.
Of duties, see "Customs Duties," § 4.

COLLISION.

§ 1. **Rules and precautions for preventing collisions in general.**

A sailing vessel, lying in a fog, but having some of her sails up, is "under way," and is governed by article 15, cl. "c," of the international navigation rules; and, where the wind is on her starboard bow, she is on the starboard tack, and the proper fog signal is one blast.—Burrows v. Gower (D. C.) 616.

§ 2. **Steam vessels meeting or crossing.**

A tug, which left a wharf when a steamer was approaching and only 400 or 500 feet distant, and attempted to cross the steamer's bows, held in fault for a resulting collision.—The Joseph M. Clark (D. C.) 459.

§§ 3-5. **Overtaking vessels.**

The fault of an overtaking vessel for a collision being established, in determining the question of the contributory fault of the vessel overtaken, every reasonable doubt should be resolved in her favor.—The Atlantis (C. C. A.) 568.

An overtaking steamer, attempting to pass a much smaller vessel in the Detroit river, held solely in fault for a collision brought about by the effect of suction.—The Atlantis (C. C. A.) 568.

A collision in the St. Clair river between two meeting barges in tow held, under the evidence, to have been caused by suction due to the too near approach to one of them of an overtaking steamer, which caused such barge to sheer and strike the other without fault on her part; the fault being solely that of the overtaking vessel.—The Fontana (C. C. A.) 853.

§ 6. **Vessels at rest, at anchor, or at piers.**

The New York statute, making it unlawful for a vessel to lie at the end of a pier, where it will obstruct the passage of other vessels going in or out of adjacent slips, under penalty of being denied recovery for damages so received, does not preclude a recovery for injuries

caused by a vessel which is not at the time either entering or leaving an adjacent dock.—The Buenos Aires (D. C.) 493; The John A. Bouker, Id.; The N. Y. Central No. 8, Id.

§ 7. **Fog or thick weather.**

A collision at sea in a thick fog between a schooner and a steamship meeting held due to inevitable accident, and without fault on the part of either vessel.—Dunton v. Allan S. S. Co. (C. C. A.) 590.

§ 8. **Narrow channels, harbors, rivers, and canals.**

A steamship which, in swinging around in East river from the position in which she was lying outside the piers, struck and injured another vessel lying at the end of a pier, held solely in fault for such injury.—The Buenos Aires (D. C.) 493; The John A. Bouker, Id.; The N. Y. Central No. 8, Id.

§ 9. **Suits for damages.**

Where a vessel is sunk in collision, and damages are awarded on the basis of her total loss, including interest on her value and her pending freight, the owner is not entitled to damages for loss of future earnings under an unexpired charter.—The Fontana (C. C. A.) 853.

Demurrage is not recoverable for the time required to make repairs on a pleasure yacht, made necessary by a collision, where no actual pecuniary loss is shown, but the amount expended for wages and provisions for the crew is allowable where they are necessary to care for the vessel.—Fisk v. City of New York (D. C.) 256.

COLOR OF TITLE.

To sustain adverse possession, see "Adverse Possession."

COMBINATIONS.

See "Conspiracy"; "Monopolies," § 1.

COMITY.

Between courts, see "Courts," § 9.

COMMERCE.

Carriage of goods and passengers, see "Carriers"; "Shipping."

COMMON CARRIERS.

See "Carriers."

COMPENSATION.

For property taken for public use, see "Eminent Domain," § 1.
Of letter carrier, see "Post Office," § 1.
Of receiver, see "Receivers," § 4.
Of referee in bankruptcy, see "Bankruptcy," § 5.
Salvage, see "Salvage," § 1.

COMPETENCY.

Of evidence in civil actions, see "Evidence," § 2.
Of experts as witnesses, see "Evidence," § 6.

COMPETITION.

Unfair competition, see "Trade-Marks and Trade-Names," § 2.

COMPLAINT.

In criminal prosecution, see "Indictment and Information."

CONCURRENT JURISDICTION.

Of courts, see "Courts," § 9.

CONDEMNATION.

Taking property for public use, see "Eminent Domain."

CONDITIONS.

Precedent to action, see "Arbitration and Award," § 1.

CONFLICT OF LAWS.

Conflicting jurisdiction of courts, see "Courts," § 9.
What law governs as to interest, see "Interest," § 1.
What law governs insurance contract, see "Insurance," § 2.

CONNECTING CARRIERS.

See "Carriers," § 1.

CONSIDERATION.

Of bill of exchange or promissory note, see "Bills and Notes," § 1.
Of contract, see "Contracts," § 1.

CONSPIRACY.

Combinations to monopolize trade, see "Monopolies," § 1.

§ 1. Civil liability.

Complaint in an action for conspiracy to induce an exchange of real estate at an overvaluation for corporate stock held not demurrable on the ground that the fraudulent representations were mere expressions of opinion as to the value of the real estate.—Andrew D. Meloy & Co. v. Donnelly (C. C.) 456.

CONSTABLES.

See "Sheriffs and Constables."

CONSTITUTIONAL LAW.**§ 1. Construction, operation, and enforcement of constitutional provisions.**

Whether or not Act Feb. 26, 1900 [U. S. Comp. St. 1901, p. 758], providing that actions by officers against the government for fees pending when Act June 27, 1898 [U. S. Comp. St. 1901, p. 753], was passed should not abate, or, if dismissed, should be restored, was constitutional, held immaterial under the facts.—United States v. McCrory (C. C. A.) 861.

§ 2. Equal protection of laws.

The operation of Pol. Code Cal. § 1662, providing for the segregation of Chinese children in separate schools, held not in violation of Const. U. S. Amend. 14.—Wong Him v. Callahan (C. C.) 381.

CONTRACTS.

Alteration, see "Alteration of Instruments."
Amendment of complaint to show breach of contract after commencement of action, see "Pleading," § 2.

Assignment, see "Assignments."

Restraining performance or breach, see "Injunction," § 1.

Specific performance, see "Specific Performance."

Subrogation to rights or remedies of creditors, see "Subrogation."

Contracts of particular classes of parties.

See "Corporations," § 4.

Contracts relating to particular subjects.

See "Interest"; "Mines and Minerals," § 2; "Patents," § 5.

Particular classes of express contracts.

See "Bailment"; "Bills and Notes"; "Insurance"; "Sales."

Affreightment, see "Shipping," § 2.

Charter parties, see "Shipping," § 1.

Stipulations in actions, see "Stipulations."

§ 1. Requisites and validity.

An agreement to convey land to one who had previously been an officer of a land office, apparently in part at least in consideration of services rendered in his capacity as such officer, is contrary to public policy and will not be enforced by the courts.—Washington Irr. Co. v. Krutz (C. C. A.) 279.

A contract may be sustained and enforced, although an executory agreement which formed a part of the consideration therefor was void, where a further consideration has been paid and accepted.—Washington Irr. Co. v. Krutz (C. C. A.) 279.

Where a party to a contract supposes that the thing he contracts for and promises to pay for will be beneficial to him, he cannot avoid his promise on the strength of a subsequent discovery that it was really nonessential or of no value.—Casserleigh v. Wood (C. C. A.) 308.

§ 2. Construction and operation.

An engineer, injured by an explosion of oil purchased by his employer, cannot maintain an action against the seller to recover for the injury, on the ground that the oil was not of the quality represented.—*Standard Oil Co. v. Murray* (C. C. A.) 572.

§ 3. Rescission and abandonment.

Though a contract shows on its face that it is terminable at the will of either party on a reasonable notice, it does not follow that the agreements therein contained would not be obligatory upon the parties, so long as they continued to act under such contract, before revoking or terminating it.—*Kenny v. Knight* (C. C.) 475.

§ 4. Actions for breach.

The refusal of one party to an executory contract containing interdependent obligations, to be performed by each party at different times, to recognize or be bound by such contract, authorizes the other party to treat it as terminated, and to bring suit for its breach at once, although the time for performance of some of the conditions by defendant has not arrived.—*Northrop v. Mercantile Trust & Deposit Co.* (C. C.) 969.

CONTRIBUTION.

Between co-tenants for payment of taxes, see "Tenancy in Common," § 1.

CONVEYANCES.

See "Assignments"; "Chattel Mortgages"; "Mortgages."

COPYRIGHTS.

See "Literary Property."

§ 1. Nature and acquisition.

Market quotations, gathered and transmitted by a telegraph company, and printed on a tape by tickers in the offices of its customers, are not copyrightable as literary property.—*National Tel. News Co. v. Western Union Tel. Co.* (C. C. A.) 294.

An author *held* not to have lost his copyright by reason of publishing a shorter title than the copy of the title filed to obtain the copyright.—*Patterson v. J. S. Ogilvie Pub. Co.* (C. C.) 451.

Complainant in a suit for an infringement of a copyright of a book printed in 1890 *held* not obliged to prove that it was printed from type set in the United States or from plates made therefrom, as required by Rev. St. § 4956 [U. S. Comp. St. 1901, p. 3407], as amended by Act March 3, 1891.—*Patterson v. J. S. Ogilvie Pub. Co.* (C. C.) 451.

An author *held* not to have abandoned his copyright of a book by reason of permitting the sale under an execution of the plates made from type set up by the author for the printing of the book.—*Patterson v. J. S. Ogilvie Pub. Co.* (C. C.) 451.

In a suit for an infringement of a copyright, evidence *held* sufficient to prove the residence of the author.—*Patterson v. J. S. Ogilvie Pub. Co.* (C. C.) 451.

A series of photographs arranged for use in a machine for producing a panoramic effect are not entitled to registry and protection by copyright as a "photograph," under Rev. St. § 4952 [U. S. Comp. St. 1901, p. 3406].—*Edison v. Lubin* (C. C.) 993.

§ 2. Infringement.

A bill for infringement of copyright *held* to sufficiently show unfair competition, and that it was impossible to segregate the pirated matter from the balance of defendant's work.—*Edward Thompson Co. v. American Law Book Co.* (C. C.) 217.

A bill for infringement of copyright *held* to sufficiently show how complainant became the proprietor of the alleged copyrighted work.—*Edward Thompson Co. v. American Law Book Co.* (C. C.) 217.

A bill for infringement of a copyright failing to allege that the title of the copyrighted work had been recorded by the librarian of congress, as provided for by Rev. St. §§ 4964, 4953 [U. S. Comp. St. 1901, pp. 3413, 3407], *held* demurrable.—*Edward Thompson Co. v. American Law Book Co.* (C. C.) 217.

An author, as against a purchaser from a buyer at an execution sale of the plates made from type set up for the printing of his book, *held* not estopped from enforcing his copyright rights.—*Patterson v. J. S. Ogilvie Pub. Co.* (C. C.) 451.

Rev. St. § 4968 [U. S. Comp. St. 1901, p. 3416], limiting actions for forfeitures or penalties under the copyright laws, is not applicable to a suit for an injunction against the damages for an infringement of a copyright.—*Patterson v. J. S. Ogilvie Pub. Co.* (C. C.) 451.

Evidence in a suit for an infringement of a copyright of a book *held* sufficient to show that the author had mailed two copies of the book addressed to the librarian of congress, notwithstanding the register of copyrights certified that he could not find any copies.—*Patterson v. J. S. Ogilvie Pub. Co.* (C. C.) 451.

CORPORATIONS.

Liability of corporate officers for infringement of patent by corporation, see "Patents," § 6. Taxation of corporations and corporate property, see "Taxation," §§ 1, 2.

Particular classes of corporations.

See "Building and Loan Associations"; "Municipal Corporations."

§ 1. Capital, stock, and dividends.

A stockholder *held* barred by laches from maintaining a suit for the cancellation of stock alleged to have been illegally issued more than 10 years before the bill was filed, where the transaction fully appeared from the books of the corporation.—*Kimbell v. Chicago Hydraulic Press Brick Co.* (C. C. A.) 102.

A bill by a stockholder *held* not to state a cause of action for the cancellation of stock issued by the corporation in payment for exclusive rights under certain patents.—*Kimbell v. Chicago Hydraulic Press Brick Co. (C. C. A.) 102.*

Evidence *held* insufficient to establish the invalidity of stock issued by a corporation in payment for services in securing contracts and options for the purchase of property which were assigned to the corporation.—*Calivada Colonization Co. v. Hays (C. C.) 202.*

A suit by a corporation to obtain the cancellation of stock issued by it *held* barred by laches when not commenced until more than 6 years after the stock was issued.—*Calivada Colonization Co. v. Hays (C. C.) 202.*

§ 2. Members and stockholders.

A proposed amendment to a bill by a stockholder of a street railway company against a city *held* not germane to the cause of action alleged in the bill.—*Elkins v. City of Chicago (C. C.) 957.*

§ 3. Officers and agents.

The rights of a director of a corporation, who purchased mortgages on its property at a discount with his own funds, but as agent and trustee for the corporation, were not enlarged by his taking title to the property through a foreclosure sale under such mortgages.—*Kroegher v. Calivada Colonization Co. (C. C. A.) 641; Calivada Colonization Co. v. Kroegher, Id.*

Action of the directors and stockholders of a corporation, showing a disposition or intention to recognize an unauthorized claim made by a director that he was entitled to be paid the face value of claims against the corporation, which he had purchased at a discount as agent and held in trust for its benefit, does not give validity to such claim, nor estop the corporation from denying his right.—*Kroegher v. Calivada Colonization Co. (C. C. A.) 641; Calivada Colonization Co. v. Kroegher, Id.*

A director of a corporation, who purchased liens on its property with his own funds under an agreement with the corporation, *held* to have made such purchase as its agent and trustee, and not to be entitled to recover the amount of a discount which he obtained from the face value of the securities.—*Kroegher v. Calivada Colonization Co. (C. C. A.) 641; Calivada Colonization Co. v. Kroegher, Id.*

§ 4. Corporate powers and liabilities.

The acceptance and retention by a corporation of the consideration paid on a contract made by its officers, with knowledge of the facts, is a ratification of such contract, although originally unauthorized.—*Washington Irr. Co. v. Krutz (C. C. A.) 279.*

Evidence that a contract made on behalf of a corporation by its officers was not objected to by the directors is competent on the issue of ratification.—*Salem Iron Co. v. Commonwealth Iron Co. (C. C. A.) 593.*

A court of equity will not, at suit of a minority stockholder, annul a lease made by the corporation of its property and franchises,

where such lease was approved by a large majority of the stockholders, and is not shown to have been induced by fraud, nor even to be detrimental to the interests of the corporation.—*Dickinson v. Consolidated Traction Co. (C. C. A.) 871.*

Under the statutes of New Jersey, which authorize a corporation to lease its property and franchises, or to take a lease of the property and franchises of another corporation, the validity of such a lease is not affected by the length of the term.—*Dickinson v. Consolidated Traction Co. (C. C. A.) 871.*

Contracts made by a corporation *held* ultra vires and void, as not within, nor incidental to, the purposes for which the corporation was organized.—*Richmond Guano Co. v. Farmers' Cotton Seed Oil Mill & Ginnery (C. C.) 709.*

Where the board of directors of a corporation authorized a committee to consider and agree to the modification of a contract, a ratification of the modifications agreed on, which would be binding on the company, may be implied from the subsequent course of conduct of the directors with respect to the contract.—*Taylor Gas Producer Co. v. Wood (C. C.) 966.*

§ 5. Insolvency and receivers.

A court of equity, in entering a decree against a corporation and in favor of a stockholder on the adjustment of matters between them, *held* to have properly deducted the amount of an assessment which it had made against the stockholder for an unpaid stock subscription in insolvency proceedings against the corporation.—*Kroegher v. Calivada Colonization Co. (C. C. A.) 641; Calivada Colonization Co. v. Kroegher, Id.*

A statutory provision that deferred payments on subscriptions to the stock of a corporation shall be payable in installments, as called for by the directors, does not affect the power of a court of equity to order such payments for the benefit of creditors in insolvency proceedings against the corporation, although no calls therefor have been made by the directors.—*Kroegher v. Calivada Colonization Co. (C. C. A.) 641; Calivada Colonization Co. v. Kroegher, Id.*

Creditors, holding notes of a corporation containing agreements to pay attorney's fees, *held* entitled to such fees from the fund distributed in insolvency.—*Richmond Guano Co. v. Farmers' Cotton Seed Oil Mill & Ginnery (C. C.) 709.*

§ 6. Dissolution and forfeiture of franchise.

In a bill by members of an insurance association for its dissolution, it is essential to allege the insolvency of the corporation and that complainants have an interest in the fund; and such allegations must be explicit and based on facts pleaded.—*Polk v. Mutual Reserve Fund Life Ass'n (C. C.) 491.*

§ 7. Foreign corporations.

Where a corporation for which a receiver has been appointed is engaged in business and owns property in different federal districts and different states, courts subsequently appointing receivers in other districts or states in auxiliary suits will, in the exercise of their

judicial discretion, treat their jurisdiction as ancillary.—*Lewis v. American Naval Stores Co. (C. C.) 391*; *Hibernia Bank & Trust Co. v. Lewis, Id.*

A federal court has jurisdiction to appoint a receiver for a corporation of another state, where by appearing and pleading to the merits it waives its exemption from being sued except in the district of its domicile.—*Lewis v. American Naval Stores Co. (C. C.) 391*; *Hibernia Bank & Trust Co. v. Lewis, Id.*

The effect of the appointment of a receiver for a corporation is to vest in him, as an officer of the court, a qualified title to all of the property of the corporation within the court's jurisdiction and the right of possession for purposes of administration and for the benefit of those ultimately shown to be entitled to it.—*Lewis v. American Naval Stores Co. (C. C.) 391*; *Hibernia Bank & Trust Co. v. Lewis, Id.*

Where a decree has been entered by a federal court appointing a receiver for the property of a corporation of another state which owns property in the district, with the consent of such corporation, other courts, in which similar suits are subsequently instituted, should recognize such court as the court of primary jurisdiction.—*Lewis v. American Naval Stores Co. (C. C.) 391*; *Hibernia Bank & Trust Co. v. Lewis, Id.*

A receiver appointed by the circuit court of the United States for the Southern district of Alabama for a New Jersey corporation owning property in the district, who obtained possession of all the property of the corporation, held entitled to hold such possession of property situated in Louisiana as against a different receiver appointed by a state court of Louisiana in proceedings instituted at a later date than those in the federal court.—*Lewis v. American Naval Stores Co. (C. C.) 391*; *Hibernia Bank & Trust Co. v. Lewis, Id.*

Constructive service on a foreign corporation under a state law applicable to corporations doing business in the state will not confer jurisdiction, where at the time of such service the corporation is not doing business in the state.—*Cady v. Associated Colonies (C. C.) 420.*

COSTS.

§ 1. Nature, grounds, and extent of right in general.

Under Mills' Ann. Code Colo. § 281, a judgment on a verdict less favorable than an offered judgment tendered by the defendant and rejected is erroneous.—*Florence Oil & Refining Co. v. Farrar (C. C. A.) 150.*

§ 2. Security for payment.

A plaintiff who has contracted to pay an attorney fee contingent on recovery cannot sue as a poor person under the federal statute, unless it is shown that the attorney interested as a beneficiary in the action is also a poor person within the terms of the statute.—*Feil v. Wabash R. Co. (C. C.) 490.*

§ 3. Amount, rate, and items.

Amounts paid sureties on bonds are not taxable as costs.—*In re Hoyt (D. C.) 987.*

CO-TENANCY.

See "Tenancy in Common."

COUNTERCLAIM.

See "Set-Off and Counterclaim."

COUNTIES.

See "Municipal Corporations."

§ 1. Fiscal management, public debt, securities, and taxation.

The unconstitutionality of a method provided by law for making special assessments to pay bonds issued by a county to pay for road improvements, if conceded, does not affect the validity of the bonds as obligations of the county, or the right of a holder to recover judgment thereon.—*Board of Com'rs of Franklin County v. Gardiner Sav. Inst. (O. C. A.) 36.*

Bonds issued by a county to pay the cost of road improvements, under Act Ohio March 26, 1890, constitute obligations of the county; and, on default in payment, a holder is entitled to a judgment at law thereon.—*Board of Com'rs of Franklin County v. Gardiner Sav. Inst. (O. C. A.) 36.*

COURTS.

Judges, see "Judges."

Removal of action from state court to United States court, see "Removal of Causes."

Review of decisions, see "Appeal and Error."

Trial by court without jury, see "Trial," § 3.

Jurisdiction of particular actions, proceedings, or subjects.

See "Bankruptcy," § 5; "Habeas Corpus," § 1.

§ 1. Establishment, organization, and procedure in general.

The district court may decline to follow the weight of authority in the United States courts, the pertinent question being as to the rulings of the supreme court or the court of appeals for that circuit.—*United States v. Adams Exp. Co. (D. C.) 240.*

§ 2. United States courts—Jurisdiction and powers in general.

The petition in an action on the bond of a government contractor, given under Act Aug. 13, 1894 [U. S. Comp. St. 1901, p. 2315], is not subject to demurrer by the surety, which is a surety company, on the ground that it is not an inhabitant of the district.—*United States v. Sheridan (C. C.) 236.*

A federal court is without jurisdiction of a suit against defendants, who are not residents of the district, where plaintiff is also a non-resident, and the only ground of jurisdiction is diversity of citizenship, unless such defendants directly waive their privilege.—*Chesapeake & O. Coal Agency Co. v. Fire Creek Coal & Coke Co. (C. C.) 942.*

The burden of proof to disprove jurisdictional averments rests on the defendants, where objection is not raised until hearing.—*Kilgore v. Norman (C. C.) 1006.*

§ 3. — Jurisdiction dependent on nature of subject-matter.

Under Act Feb. 26, 1900 [U. S. Comp. St. 1901, p. 758], providing that actions by officers against the government for fees, pending when Act June 27, 1898 [U. S. Comp. St. 1901, p. 753], was passed, should not be abated, and, if dismissed, should be restored, a certain action *held* properly restored to the trial docket.—United States v. McCrory (C. C. A.) 861.

The adoption by a city council of the report of a committee finding that the franchise of a street railroad company will expire at a certain time, contrary to the contention of the company, and recommending action for its disposition at the expiration of such time, does not constitute legislation which can be said to impair the obligation of the company's contract, so as to give a federal court jurisdiction of a suit to determine the term of the company's franchise, on the ground that it involved a federal question.—Elkins v. City of Chicago (C. C.) 957.

In an action at law plaintiff cannot give a federal court jurisdiction, on the ground that the action is one arising under the constitution or laws of the United States, by alleging facts which are properly matters of defense and not necessary to a statement of his cause of action.—Filhiol v. Torney (C. C.) 974.

§ 4. — Jurisdiction dependent on citizenship, residence, or character of parties.

To confer jurisdiction on a federal court of an action on the bond of a government contractor, conditioned as required by Act Aug. 13, 1894 [U. S. Comp. St. 1901, p. 2315], brought in the name of the United States for the use and benefit of one who furnished labor or material, there must be diversity of citizenship between the parties, and the amount involved must exceed \$2,000, exclusive of interest and costs.—United States v. Sheridan (C. C.) 236.

A defendant *held*, under the allegations of the bill, to be not merely a nominal party, but a real party in interest, whose citizenship in the same state as complainant defeated the jurisdiction of the court.—Post v. Buckley (C. C.) 249.

A suit to enjoin the attorney general of a state from instituting criminal prosecutions in the name of the state, under a state statute toward which he occupies no different relation than toward any other penal statute, is a suit against the state, within the meaning of the eleventh constitutional amendment, of which a federal court is without jurisdiction.—Union Trust Co. v. Stearns (C. C.) 790.

Allegations in a bill by a stockholder in a suit to enforce rights which might have been asserted by the corporation *held* insufficient to comply with the requirements of equity rule 94, or to give a federal court jurisdiction on the ground of diversity of citizenship, where the corporation and its codendants were citizens of the same state for jurisdictional purposes.—Elkins v. City of Chicago (C. C.) 957.

§ 5. — Amount in controversy.

In a suit by a taxpayer to enjoin a city from issuing bonds claimed to be in excess of the constitutional limit of its indebtedness, the power of the city to issue such bonds is the matter in dispute, for the purpose of determining whether the amount or value in controversy is sufficient to give a federal court jurisdiction, and not the tax to which complainant would be subjected.—City of Ottumwa v. City Water Supply Co. (C. O. A.) 315.

In an action to recover land occupied by a railroad company for its depot, the value of the land to the defendant constitutes the amount involved in determining the jurisdiction.—King v. Southern Ry. Co. (C. C.) 1016.

§ 6. — Procedure, and adoption of practice of state courts.

Where a jurisdictional allegation in a plaintiff's pleading in an action at law in a federal court is denied by the answer, and the code practice of the state permits matters in abatement to be pleaded by answer, an issue of fact is thus joined, which must be tried, although it should be submitted to the jury separate and distinct from the other issues.—Roberts v. Langenbach (C. C. A.) 349.

Neither the statutes nor decisions of the courts of a state can confer authority on a federal court sitting therein to exercise equitable jurisdiction in actions at law.—Goodyear Shoe Machinery Co. v. Dancel (C. C. A.) 692.

The settlement of a bill of exceptions in a federal court is governed by the federal statutes and practice, and not by the statutes or practice of the states.—Green v. Fitchburg R. Co. (C. C. A.) 872.

The authority of a federal court into which a cause has been removed to determine whether the state court, by the service made, acquired jurisdiction over the defendant, a foreign corporation, to render judgment against it, is neither derived from nor limited by the laws of the state; nor is such court concluded by the decision of the state court thereon.—Cady v. Associated Colonies (C. C.) 420.

A motion for an adjudication by the court that the cause of action arose from the willful and malicious act of the defendants, and that they ought to be confined in close jail, and for a certificate thereof upon the execution, according to V. S. § 1751, cannot prevail, under Rev. St. U. S. §§ 914, 916 [U. S. Comp. St. 1901, p. 684].—Friedly v. Giddings (C. C.) 438.

Rev. St. § 916 [U. S. Comp. St. 1901, p. 684], giving a judgment creditor in a federal court the benefit of remedies provided by the state statute for the enforcement of judgments in like cases, does not embrace equitable remedies.—Hudson v. Wood (C. C.) 764.

A federal court, in a creditors' suit in equity, cannot try the question of the indebtedness of a defendant to the judgment debtor on a legal demand, where such indebtedness is denied, although it may compel a discovery from him, and appoint a receiver with authority to sue at

law on the demand for the complainant's benefit.—Hudson v. Wood (C. C.) 764.

§ 7. — State laws as rules of decision.

The validity of an act authorizing the issuance of municipal bonds is determinable in a federal court by the law, as declared by the highest court of the state when the bonds were issued and sold, and a subsequent purchaser is not affected by a change in the law made by later decisions, although prior to his purchase.—Board of Com'rs of Franklin County v. Gardiner Sav. Inst. (C. C. A.) 36.

Decision of the supreme court of Tennessee that conductor was vice principal toward brakeman held, in view of other decisions of that court and of Shannon's Code Tenn. §§ 4026-4029, not to be a construction of section 4025, relating to abatement of actions for wrongful death, binding on the federal courts.—Elliott v. Felton (C. C. A.) 270.

While a federal court is bound by the construction placed by the highest court of a state upon its statutes, it is not bound by the application made by the state court of such statute to a particular contract.—Casserleigh v. Wood (C. C. A.) 308.

While the federal courts are bound by the construction placed by the highest court of a state on a state statute or constitutional provision, when it becomes necessary to apply the statute or provision as thus construed by the local courts to a particular contract, and determine from a consideration of all its provisions whether it is a violation of the law, a federal court is entitled to express an independent judgment.—City of Ottumwa v. City Water Supply Co. (C. C. A.) 315.

Federal courts follow the decisions of the highest court of a state, construing its constitution or statutes; and where such a decision is overruled, pending an appeal from the judgment of a federal court based thereon, the appellate court will reverse such judgment, if no question of contract rights is involved.—American Sugar Refining Co. v. City of New Orleans (C. C. A.) 691.

A rule of evidence declared by the supreme judicial court of Massachusetts in actions on life insurance policies under the statute held binding on a federal court as applied to a contract made in the state by a foreign company after the statute had been so interpreted.—Albro v. Manhattan Life Ins. Co. (C. C.) 629.

§ 8. — Circuit courts of appeals.

An order of a circuit court refusing to adjudge expenses of a receivership in excess of the proceeds of the property against the complainant, on the ground that the court was without authority to grant the petition of the receiver therefor, does not involve any question of jurisdiction, and an appeal therefrom lies to the circuit court of appeals.—Chapman v. Atlantic Trust Co. (C. C. A.) 257.

§ 9. Concurrent and conflicting jurisdiction, and comity.

The rule stated as to when priority of jurisdiction obtained by a state or federal court will

defeat a second suit in the other jurisdiction.—Baltimore & O. R. Co. v. Wabash R. Co. (C. C. A.) 678.

A federal court has jurisdiction to grant an injunction to restrain a railroad company from obstructing another company in constructing a crossing over its tracks, when the right has been granted by a decree of a state court, notwithstanding the pendency of an appeal from such decree, where such appeal does not operate as a supersedeas.—Baltimore & O. R. Co. v. Wabash R. Co. (C. C. A.) 678.

A state court is without jurisdiction to enjoin an officer of the United States army from doing a work which he is commanded to perform by his superior officer in the execution of an act of congress; and, such an injunction being void, its disobedience by the officer is not a contempt, and his arrest and detention therefor is without legal authority.—Sheriff v. Turner (C. C.) 231.

Where creditors of a corporation had notice of receivership proceedings in the state courts, and opportunity to prove their claim, a federal court will not interfere to protect their rights.—Dobson v. Peck Bros. & Co. (C. C.) 254.

Where the owner of a vessel is an insolvent corporation, represented in a suit to enforce maritime liens on such vessel by a receiver appointed by a state court in insolvency proceedings, the admiralty court will not apply the remnants of funds remaining in its registry to the payment of maritime creditors who have proved their claims, but have been adjudged without lien, but will pay over the same to the receiver, to be distributed in accordance with the laws of the state.—The Liberty (D. C.) 539.

COVENANTS.

In leases, see "Landlord and Tenant," § 2.

CREDIBILITY.

Of witness, see "Witnesses," § 2.

CREDITORS.

See "Bankruptcy"; "Creditors' Suit."

Subrogation to rights of creditors, see "Subrogation."

CREDITORS' SUIT.

A defendant in a creditors' suit, from whom discovery is prayed in respect to his indebtedness to the judgment debtor, cannot object to the making of such discovery because the bill waives answer under oath.—Hudson v. Wood (C. C.) 764.

CRIMINAL LAW.

Indictment, information, or complaint, see "Indictment and Information."

Particular offenses.

See "False Personation"; "Obstructing Justice."
 Offenses against customs laws, see "Customs Duties," § 5.
 Offenses against internal revenue laws, see "Internal Revenue."
 Offenses against postal laws, see "Post Office," § 2.

CROSS-EXAMINATION.

Of witnesses, see "Witnesses," § 1.

CURTESY.

A tenant by the curtesy cannot convey the right to a lessee to extract oil from the land, and a lease executed by him purporting to convey such right is void.—*Barnsdall v. Boley* (C. C.) 191.

CUSTOMS DUTIES.**§ 1. Validity, construction, and operation of customs laws in general.**

Goods tendered for consumption entry before 4 o'clock on July 24, 1897, *held* dutiable under the tariff act of 1894, and not the act of 1897 [U. S. Comp. St. 1901, p. 1626].—*United States v. Perkins* (C. C.) 384.

Customs Administrative Act, § 20 [U. S. Comp. St. 1901, p. 1950], construed, and *held* not to relieve importer of goods from Porto Rico before cession to United States from liability for duties, though before withdrawal of goods from bonded warehouse Porto Rico had become United States territory.—*Mosle v. Bidwell* (C. C.) 480.

§ 2. Goods subject to duty, rate, and amount.

Shells which have been treated with chloride of lime and washed with water to cleanse them, though such cleansing adds slightly to their value, are not thereby "advanced in value from their natural state," but are entitled to free entry, under paragraph 635 of the free list in the tariff act of 1897 [U. S. Comp. St. 1901, p. 1686].—*Schoenemann v. United States* (C. C. A.) 534.

Chinese spirituous beverages, imported in bottles containing on the average one tenth of one gallon and in spirituous strength below proof, are dutiable at \$2 per gallon under paragraph 311 of the tariff act of 1883.—*Kwong Chin Chong v. United States* (C. C.) 383; *Yuet Sing v. Same, Id.*; *Wing Wo Chong v. Same, Id.*

Bottles containing Chinese spirituous beverages assessable under paragraph 311 of the tariff act of 1883 are themselves subject to duty of three cents each under paragraph 310.—*Kwong Chin Chong v. United States* (C. C.) 383; *Yuet Sing v. Same, Id.*; *Wing Wo Chong v. Same, Id.*

Crude hematite ore *held* assessable as "iron ore," within paragraph 121, Tariff Act July 24, 1897 [U. S. Comp. St. 1901, p. 1636], and not

as "color," under paragraph 58.—*Francklyn v. United States* (C. C.) 470.

Salol *held* dutiable under Tariff Act 1890, par. 76, and not under paragraph 74.—*Schering v. United States* (C. C.) 472.

Hyoscin hydrobromate *held* dutiable under Tariff Act 1890, par. 74, and not under paragraph 76.—*Schering v. United States* (C. C.) 472.

Chloral hydrate *held* dutiable under Tariff Act 1897, par. 67 [U. S. Comp. St. 1901, p. 1631], and not under paragraph 66 [page 1630].—*United States v. Schering* (C. C.) 473.

Imitations of pearls, made of paste or glass and mounted on wires, are dutiable under paragraph 454 of the tariff act of 1890, and under paragraph 338 of the tariff act of 1894 as "imitations of precious stones not set," and not under paragraph 108 of the act of 1890 as "manufactures of glass not specially provided for," or under paragraph 351 of the act of 1894 as "manufactures of paste not specially provided for."—*Lorsch v. United States* (C. C.) 476.

Canary seed is not free from duty, under paragraph 656 of the tariff act of 1897 [U. S. Comp. St. 1901, p. 1687], as "grass seeds" not specially provided for, but is dutiable, under paragraph 254 [page 1650], as "seeds not specially provided for."—*United States v. Nordlinger* (C. C.) 478; *Same v. McElroy, Id.*

Fire brick not capable of decoration, over 10 pounds in weight, *held* dutiable under the similitude clause of section 7 of the tariff act of 1897 [U. S. Comp. St. 1901, p. 1693], under paragraph 87 [page 1632] as undecorated fire brick weighing not more than 10 pounds, and not under paragraph 97 [page 1633].—*Wing v. United States* (C. C.) 479.

Boxes used as coverings for imported tobacco, but which are valueless, and are destroyed after the tobacco is removed, *held* not taxable under Act June 10, 1890, § 19 [U. S. Comp. St. 1901, p. 1924].—*Laverge v. United States* (C. C.) 481.

Sago flour is entitled to free entry under paragraph 552 of the tariff act of 1897 [U. S. Comp. St. 1901, p. 1687] as "sago, crude," and not dutiable under paragraph 235 [page 1653] as "starch," or under paragraph 20 [page 1628] as a drug, or under section 6 [page 1693] covering raw or unmanufactured articles not otherwise provided for.—*Littlejohn v. United States* (C. C.) 483; *United States v. Littlejohn, Id.*

Ginger ale, imported when tariff act of 1894 was in effect, *held* liable under paragraph 243 for a duty of 20 per cent. ad valorem, but not for any duty on the cost of corking, labeling, etc.—*West v. United States* (C. C.) 495.

§ 3. Entry and appraisal of goods, bonds, and warehouses.

There is no provision of law requiring the liquidation of duties before or at the time of entry, and the provision limiting the time for reliquidation has no application until after liquidation has once been made.—*Abner Doble Co. v. United States* (C. C. A.) 152.

§ 4. Payment and collection, refunding, and drawback.

A complaint by the United States *held* to state a cause of action for the recovery of duties from defendant.—*Abner Doble Co. v. United States* (C. C. A.) 152.

§ 5. Violations of customs laws.

The right of a seller of goods obtained by fraud to rescind the sale and reclaim the goods cannot be asserted against the right of the United States to forfeit the same, where they were seized when the purchaser, while clothed with the ownership and possession, was attempting to smuggle them into the country in violation of the customs laws.—*Five Hundred Eighty-One Diamonds v. United States* (C. C. A.) 566.

DAMAGES.

Compensation for property taken for public use, see "Eminent Domain," § 1.

Damages for particular injuries.

See "Collision," § 9; "Death," § 1; "Libel and Slander," § 1.

Breach by seller of contract for sale of goods, see "Sales," § 3.

Failure to deliver goods, see "Sales," § 2.

Wrongful execution of attachment, see "Sheriffs and Constables," § 1.

§ 1. Grounds and subjects of compensatory damages.

Where libellant is entitled to damages for the detention of a vessel for repairs, interest can be allowed in the discretion of the court.—*Harrison v. Hughes* (D. C.) 997.

§ 2. Pleading, evidence, and assessment.

A general verdict for damages *held* proper, and not to be set aside for want of a statement as to how much of the damages were exemplary and how much actual.—*Friedly v. Giddings* (C. C.) 438.

DEATH.

Of bankrupt, see "Bankruptcy," § 7.

§ 1. Actions for causing death.

The Nevada statute giving a right of action for wrongful death construed, and a complaint based thereon *held* sufficient.—*Peers v. Nevada Power, Light & Water Co.* (C. C.) 400.

The complaint in an action for wrongful death should state the names of the kindred of the deceased who are entitled to share in the recovery by the terms of the statute; but, where the names of such kindred are given, it is not necessary to expressly negative the existence of relatives other than those named.—*Peers v. Nevada Power, Light & Water Co.* (C. C.) 400.

The complaint, in an action for wrongful death under a statute which authorizes the jury to give such damages, pecuniary and exemplary, as they shall deem fair and just, need not allege what part, or whether any, of the damages prayed for are claimed as exemplary.—*Peers v. Nevada Power, Light & Water Co.* (C. C.) 400.

Damages awarded against the owner of a tug in favor of the next of kin of a scowman

119 F.—66

whose death was due to the tug's negligence.—*The O. L. Hallenbeck* (D. C.) 468; *Olsen v. Cahill*, *Id.*

DEBTOR AND CREDITOR.

See "Bankruptcy"; "Creditors' Suit."

DECEIT.

See "Fraud."

DECISION.

Following decisions of state courts as to construction of statutes, see "Courts," § 7.

DECLARATIONS.

As evidence in civil actions, see "Evidence," § 4.

DECREE.

In admiralty, see "Admiralty," § 3.
In equity, see "Equity," § 5.

DEEDS.

As evidence, see "Evidence," § 5.
Of trust, see "Mortgages."

DEFAMATION.

See "Libel and Slander."

DEMURRAGE.

See "Collision," § 9.

DEMURRER.

In pleading, see "Pleading," § 1.
To indictment, see "Indictment and Information," § 1.

DESCENT AND DISTRIBUTION.

See "Curtesy."

DISCHARGE.

From indebtedness, see "Bankruptcy," § 7.

DISCOVERY.

See "Creditors' Suit"; "Equity," § 2.

§ 1. In equity.

A creditor of an insolvent railroad company is not entitled to a discovery in respect to the prices paid for claims against the company by its president, who purchased for a third person having full right to buy the same, unless a conspiracy to defraud stockholders and creditors is first shown.—*Cassidy Fork Boom & Lumber Co. v. Roaring Creek & C. R. Co.* (C. C.) 425.

§ 2. Under statutory provisions.

Under Rev. St. U. S. § 724 [U. S. Comp. St. 1901, p. 583], a party litigant *held* entitled to compel production and inspection of books before trial at law.—Gray v. Schneider (C. C.) 474.

Terms of order compelling production and inspection of books before trial at law stated.—Gray v. Schneider (C. C.) 474.

DISMISSAL AND NONSUIT.

Dismissal of appeal or writ of error, see "Appeal and Error," § 5.

DISSOLUTION.

Of corporation, see "Corporations," § 6.

DIVERSE CITIZENSHIP.

Ground of jurisdiction of United States courts, see "Courts," § 4; "Removal of Causes," § 3.

DOCUMENTS.

As evidence in civil actions, see "Evidence," § 5.

Production and inspection of writings, see "Discovery," § 2.

DOMICILE.

Residence, as ground of jurisdiction, see "Courts," § 4.

Residence for purpose of copyright, see "Copyrights," § 1.

DOWER.

See "Curtesy."

Allowance to widow of bankrupt, see "Bankruptcy," § 7.

DUTIES.

Customs duties, see "Customs Duties."
Excise duties, see "Internal Revenue."

EJECTMENT.**§ 1. Right of action and defenses.**

Under the law of Tennessee a plaintiff cannot recover in ejectment without showing a perfect legal title, either by deraignment or by actual adverse possession under color of title for the full term of seven years.—Stockley v. Cissna (C. C. A.) 812.

§ 2. Pleading and evidence.

A plaintiff in ejectment *held* not to have shown a sufficient title to support the action.—Stockley v. Cissna (C. C. A.) 812.

ELECTION OF REMEDIES.

A party to a contract, who has brought an action at law for its breach, and prosecuted

the same to a judgment for damages, cannot thereafter maintain a suit in equity to enforce specific performance.—Slaughter v. La Compagnie Francaises Des Cables Telegraphiques (C. C. A.) 588.

ELECTIONS.**§ 1. Count of votes, returns, and canvass.**

Under Rev. St. §§ 109, 123 [U. S. Comp. St. 1901, pp. 60, 63], a district judge has power, on proper application, at any time after a contest of the election of a congressman has been instituted, to order the ballots cast at the election taken from the boxes and preserved as evidence, where it is shown that under the state law they would otherwise be destroyed before they could be used.—In re Howell (D. C.) 465.

EMINENT DOMAIN.

Removal of condemnation proceedings to federal court, see "Removal of Causes," § 3.

§ 1. Compensation.

Under the Illinois constitution, a city is not relieved from liability for damage caused to property by the construction of a viaduct in a street, because it was built by the city in the exercise of its police power.—City of Chicago v. Le Moyne (C. C. A.) 662.

A city, which caused the construction of a viaduct in a street, cannot escape liability for damages caused to abutting property on the ground that the order under which it was built was void.—City of Chicago v. Le Moyne (C. C. A.) 662.

Evidence *held* admissible to show damage to property resulting from the construction of a viaduct on the street in front of it.—City of Chicago v. Le Moyne (C. C. A.) 662.

Benefits accruing to a property owner, in common with the public generally, from the building of a street railway line on a street, cannot be offset against actual damages caused to his property by a viaduct built on such street by the city.—City of Chicago v. Le Moyne (C. C. A.) 662.

A city in which land is dedicated for a public park *held* entitled to contest its condemnation for a post office, though not entitled to compensation.—In re Certain Land in Lawrence (D. C.) 453.

§ 2. Remedies of owners of property.

Instructions with respect to the measure of damages recoverable for an injury to property, by reason of the construction of a viaduct on the street in front of it, examined, and *held* free from material error.—City of Chicago v. Le Moyne (C. C. A.) 662.

Land entered and possessed by a railroad company for railroad purposes, with or without the owner's consent, cannot be recovered by a subsequent vendee of the owner.—King v. Southern Ry. Co. (C. C.) 1017.

A declaration in an action to recover land *held* to show that plaintiff acquired title sub-

sequent to the occupation of the land by defendant railroad company for railroad purposes, and was therefore demurrable.—*King v. Southern Ry. Co.* (C. C.) 1017.

EMPLOYES.

See "Master and Servant."

ENTRY.

Of imported goods, see "Customs Duties," § 3.
Of public lands, see "Public Lands," § 2.

ENTRY, WRIT OF.

See "Ejectment."

EQUITY.

Particular subjects of equitable jurisdiction and equitable remedies.

See "Creditors' Suit"; "Discovery," § 1; "Injunction"; "Partition," § 1; "Receivers"; "Specific Performance."

Suits for infringement of patents, see "Patents," § 6.

§ 1. Jurisdiction, principles, and maxims.

A bill *held* demurrable on the ground that complainant had an adequate remedy at law.—*Sawyer v. Atchison, T. & S. F. R. Co.* (C. C.) 252.

Complainants cannot invoke the aid of a court of equity to maintain them in the possession of property which they took by force from defendants, who are conceded to have been in possession under a deed purporting to convey to them the legal title, by enjoining defendants from prosecuting an action at law for its recovery.—*David v. Levy* (C. C.) 799.

A federal court of equity *held* to have jurisdiction of a suit to recover lands and to cancel deeds on the ground of fraud.—*Kilgore v. Norman* (C. C.) 1006.

§ 2. Pleading.

A bill praying that complainant be adjudged the owner of certain land, that writings under which defendants claimed the same be canceled, and for a writ of possession, *held* not to state facts constituting a cause of action for relief in equity.—*Bent v. Hall* (C. C. A.) 342.

An order sustaining a demurrer to a bill in one of its two aspects *held* to be interlocutory only, and not to deprive the court of power to thereafter permit an amendment relating to that feature of the bill.—*Globe-Wernicke Co. v. Fred Macey Co.* (C. C. A.) 696.

Laches need not be pleaded as a defense, but it is sufficient to defeat relief in a court of equity if it appears from the evidence.—*Calivada Colonization Co. v. Hays* (C. C.) 202.

A defendant cannot be required to answer an interrogatory requiring it to state how an

article manufactured by it is constructed, if not constructed as charged in the bill, where it states that such construction is a trade secret.—*Federal Mfg. & Printing Co. v. International Bank Note Co.* (C. C.) 385.

The fact that interrogatories filed with a bill are not specifically referred to therein, in conformity to equity rule 43, does not excuse defendant from answering the same, where he is not prejudiced by the informality.—*Federal Mfg. & Printing Co. v. International Bank Note Co.* (C. C.) 385.

Various exceptions to the answers of defendants in a suit in equity considered and overruled.—*Cassidy Fork Boom & Lumber Co. v. Roaring Creek & C. R. Co.* (C. C.) 425.

A creditors' bill *held* multifarious as against a defendant charged with being indebted to the judgment debtor.—*Hudson v. Wood* (C. C.) 764.

A bill by the heirs of a husband and wife to recover lands is not multifarious because the title to some of the lands was vested in the husband, to some in the wife, and to some in both, nor because defendants claim through various sources of title.—*Kilgore v. Norman* (C. C.) 1006.

§ 3. Evidence.

Evidence *held* insufficient to establish the allegations of a bill against the sworn answers and testimony of defendants.—*Coonrod v. Kelly* (C. C. A.) 841.

Unless answer under oath is expressly waived in the bill, such answer, if responsive, is evidence on behalf of the defendant, and, to overcome it, complainant must have at least one sustaining witness and corroborative circumstances.—*Calivada Colonization Co. v. Hays* (C. C.) 202.

§ 4. Masters and commissioners, and proceedings before them.

On an accounting before a master for profits and damages for infringement of a patent, where defendant has produced the contracts of sale of the infringing machines, he may properly be required, under the provisions of equity rule 77, to also produce the correspondence leading up to such contracts, as being applicable to the subject-matter of the reference.—*Goss Printing Press Co. v. Scott* (C. C.) 941.

§ 5. Decree and enforcement thereof.

Though a defendant may be in default, the complainant is not entitled to a decree pro confesso, where the allegations of his complaint are insufficient to support a decree in his favor.—*Wong Him v. Callahan* (C. C.) 381.

§ 6. Bill of review.

Where the rights of persons who were not parties to a suit in equity are affected by the decree entered therein, and they seek to obtain a modification of such decree by setting up matters which occurred pending the suit, but which were not presented to the court, the proper practice is by the filing of a supplemental bill, in the nature of a bill of review.—*Thompson v. Schenectady Ry. Co.* (C. C.) 634.

A supplemental bill after decree, in the nature of a bill of review, cannot be filed without leave of court; but it is discretionary with the court whether to require notice to the defendants therein, or the parties to the decree, before granting such leave.—*Thompson v. Schenectady Ry. Co.* (C. C.) 634.

A supplemental bill, in the nature of a bill of review, filed by persons who were not parties to the prior decree, *held* to show such equity in complainants as to entitle them to a hearing.—*Thompson v. Schenectady Ry. Co.* (C. C.) 634.

ERROR, WRIT OF.

See "Appeal and Error."

ESTABLISHMENT.

Of trusts, see "Trusts," § 1.

ESTATES.

By curtesy, see "Curtesy."
Tenancy in common, see "Tenancy in Common."

ESTOPPEL.

By judgment, see "Judgment," § 3.
By judgment of land department, see "Public Lands," § 2.
To dispute discovery of mineral, see "Mines and Minerals," § 1.
To dispute validity of patent, see "Patents," § 2.

EVIDENCE.

See "Discovery"; "Witnesses."
Review on appeal or writ of error, see "Appeal and Error," § 6.
Verdict or findings contrary to evidence, see "New Trial," § 1.

As to particular facts or issues.

See "Adverse Possession," § 2.
Damages caused by taking property for public use, see "Eminent Domain," § 1.
Existence of riot, see "Municipal Corporations," § 1.
Mining claims, see "Mines and Minerals," § 1.
In actions by or against particular classes of parties.

Employers, see "Master and Servant," § 1.

In particular civil actions or proceedings.

See "Ejectment," § 2; "Negligence," § 2.
Equity, see "Equity," § 3.
Foreclosure, see "Mortgages," § 2.
For infringement of copyright, see "Copyrights," § 2.
For infringement of patent, see "Patents," § 6.
For price of goods, see "Sales," § 2.
For wrongful death of servant, see "Master and Servant," § 1.
On insurance policy, see "Insurance," § 6.
On reference in equity, see "Equity," § 4.

§ 1. Judicial notice.

In determining the novelty of a patented device, the court will take judicial notice of matters of common knowledge relating to the state of the prior art.—*Farmers' Mfg. Co. v. Spruks Mfg. Co.* (C. C.) 594.

§ 2. Relevancy, materiality, and competency in general.

Where, in an action for a breach of an alleged contract of sale, plaintiff introduced only a part of the correspondence between the parties on the subject, *held* not error to admit all the correspondence and conversations relating to the matter.—*Elizabeth City Cotton Mills v. Loeb* (C. C. A.) 154.

Where a patent sued on is intelligible without evidence, but defendant introduces expert testimony, it is proper for complainant to introduce the same kind of testimony in rebuttal.—*Hutter v. De Q. Bottle Stopper Co.* (C. C.) 190.

§ 3. Best and secondary evidence.

It is no objection to the admissibility in evidence of a plat made by a witness from a survey made by him, showing the location and surroundings of property for injury to which the action is brought, that it is not the best evidence and that the official plat should be produced.—*City of Chicago v. Le Moyne* (C. C. A.) 662.

§ 4. Declarations.

Where the good faith of a trespasser is in issue, his acts and sayings in relation to the trespass at or about the time thereof are competent.—*United States v. Gentry* (C. C. A.) 70.

§ 5. Documentary evidence.

The exclusion of a sketch made by a witness to illustrate his testimony *held* within the discretion of the court.—*City of Chicago v. Le Moyne* (C. C. A.) 662.

Recitals in a deed of recent origin that the makers are the heirs of a former owner, without circumstances in support, are not evidence against a stranger.—*Stockley v. Cissna* (C. C. A.) 812.

In proceedings for deportation of Chinese person, certificate of prior adjudication of defendant's right to remain in the United States *held* inadmissible in proof of such adjudication.—*United States v. Lew Poy Dew* (D. C.) 786.

§ 6. Opinion evidence.

Dealers in precious stones only are not competent to testify as to the commercial uses of ornaments claimed to be imitations of precious stones.—*Lorsch v. United States* (C. C.) 476.

In stating their opinion as to the valuation of a building destroyed, witnesses should be required to state the grounds on which the estimates are based; otherwise, the value of the estimates cannot be determined.—*Hawes v. Warren* (C. C.) 978.

EXAMINATION.

Of witnesses in general, see "Witnesses," § 1.

EXCEPTIONS.

To proceedings before referee in bankruptcy, see "Bankruptcy," § 5.

EXCEPTIONS, BILL OF.

Following practice of state courts, see "Courts," § 6.

EXCISE.

Duties, see "Internal Revenue."

EXECUTION.

See "Attachment."

EXECUTORS AND ADMINISTRATORS.

Revenue tax on administrator's bond, see "Internal Revenue."

EXEMPTIONS.

Of bankrupt, see "Bankruptcy," § 7.

EXPERT TESTIMONY.

In civil actions, see "Evidence," § 6.

FALSE PERSONATION.

An indictment against defendants for obtaining money from an alleged violator of Revenue Act June 3, 1898 [U. S. Comp. St. 1901, p. 2293], by impersonating a United States officer, held sufficient.—United States v. Brown (C. C.) 482.

An indictment for violation of Act April 18, 1884 [U. S. Comp. St. 1901, p. 3679], prohibiting the impersonation of United States officers, held sufficient.—United States v. Brown (C. C.) 482.

FEDERAL COURTS.

See "Courts," §§ 2-8.

FEDERAL QUESTIONS.

Grounds for jurisdiction, see "Courts," § 3.
Ground for removal of cause, see "Removal of Causes," § 2.

FELLOW SERVANTS.

See "Master and Servant," § 1.

FINAL JUDGMENT.

Review, see "Appeal and Error," § 1.

FINDINGS.

On trial by court, see "Trial," § 3.
Review on appeal or writ of error, see "Appeal and Error," § 6.

FISH.

Fishery rights on tide lands, see "Public Lands," § 2.

FIXTURES.

According to the law of Vermont, the main belt of a steam marble mill, connecting the drive wheel with the main shafting and furnishing the motive power, is a part of the realty.—Friedly v. Giddings (C. C.) 438.

FOG.

Collision of vessels, see "Collision," § 7.

FORECLOSURE.

Of mortgage, see "Chattel Mortgages," § 1;
"Mortgages," § 2.

FOREIGN CORPORATIONS.

See "Corporations," § 7.

FOREIGN RECEIVERSHIP.

See "Receivers," § 5.

FORFEITURES.

For violation of customs laws, see "Customs Duties," § 5.
Of franchise, see "Corporations," § 6.
Of insurance, see "Insurance," § 7.
Of leases, see "Landlord and Tenant," § 2.
Of oil lease, see "Mines and Minerals," § 2.

FORMER ADJUDICATION.

See "Judgment," § 3.

FORMS OF ACTION.

See "Ejectment."

FRAUD.

Conspiracy to defraud, see "Conspiracy," § 1.
§ 1. **Deception constituting fraud, and liability therefor.**

A letter construed, and held not to contain an implied representation that certain bonds were valid, which rendered the writer liable in an action for deceit, where there was no fraudulent intent.—Sprigg v. Commonwealth Title Ins. & Trust Co. (C. C.) 434.

§ 2. **Actions.**

The Michigan statute authorizing recovery of damages for an injury resulting from false representations by an action in assumpsit on an implied promise merely creates a new remedy and does not give a right of action until damages have resulted.—In re Pennewell (C. C. A.) 139.

FRAUDULENT CONVEYANCES.

By bankrupt, see "Bankruptcy," § 4.

GARNISHMENT.

See "Attachment."

GRAND JURY.

See "Indictment and Information."

GRANTS.

Of public lands, see "Public Lands."

HABEAS CORPUS.**§ 1. Jurisdiction, proceedings, and relief.**

The circuit and district courts have authority on habeas corpus by a prisoner committed for removal to a foreign district to answer an indictment to examine the indictment and discharge the prisoner in case it is fundamentally bad.—*Stewart v. United States* (C. C. A.) 89.

A federal court will discharge an officer of the United States army on writ of habeas corpus from arrest and detention by state authorities while in the discharge of his official duties.—*In re Turner* (D. C.) 231.

HARMLESS ERROR.

In civil actions, see "Appeal and Error," § 6.

HIGHWAYS.

See "Navigable Waters," § 1.

HUSBAND AND WIFE.

See "Curtesy."

IMPORTS.

Duties, see "Customs Duties."

IMPRISONMENT.

Habeas corpus, see "Habeas Corpus."

IMPROVEMENTS.

Liens, see "Mechanics' Liens."

INDIANS.

Act Aug. 15, 1894 (28 Stat. 305), confers on a circuit court of the United States jurisdiction to decree relief to an Indian entitled under the law to an allotment of certain lands, of which right he has been deprived by the rulings of

the land department.—*Hy-yu-tse-mil-kin v. Smith* (C. C. A.) 114.

Where a suit by an Indian, under Act Aug. 15, 1894 (28 Stat. 305), to determine the right to an allotment of land, involves simply a question of priority of right to an allotment of a particular tract as between two claimants, the United States is not a necessary party.—*Hy-yu-tse-mil-kin v. Smith* (C. C. A.) 114.

An Indian woman deprived of lands selected and improved by her, through an erroneous decision of the department that she was not entitled to an allotment, and on the reversal of such ruling allotted other lands, held entitled to recover those selected from an allottee who took with notice of her rights.—*Hy-yu-tse-mil-kin v. Smith* (C. C. A.) 114.

The fact that an Indian woman who was a member of the Walla Walla tribe was not residing on the reservation at the time the list of those entitled to allotment of lands was made up, but was living with her family on public lands outside, which members of the tribe habitually occupied for hunting, fishing, and pasturage purposes, and were permitted by treaty to so occupy, did not deprive her of her right to an allotment.—*Hy-yu-tse-mil-kin v. Smith* (C. C. A.) 114.

INDICTMENT AND INFORMATION.*For particular offenses.*

See "False Personation"; "Obstructing Justice."

Offenses against postal laws, see "Post Office," § 2.

§ 1. Motion to quash or dismiss, and demurrer.

Where a demurrer goes both to the indictment and the bill of particulars, and is so treated by counsel on both sides, the court may so consider it, to avoid a useless trial of the indictment, though the law does not require it to do so.—*United States v. Adams Exp. Co.* (D. C.) 240.

§ 2. Issues, proof, and variance.

On prosecution for crime, the court will limit the government in its evidence to those facts set forth in the bill of particulars.—*United States v. Adams Exp. Co.* (D. C.) 240.

INDORSEMENT.

Of bill of exchange or promissory note, see "Bills and Notes," § 2.

IN FORMA PAUPERIS.

See "Costs," § 1.

INFRINGEMENT.

Of copyright, see "Copyrights," § 2.
Of patent, see "Patents," § 6.
Of trade-mark, see "Trade-Marks and Trade-Names," § 2.

INJUNCTION.

Infringement of patent, see "Patents," § 6.

§ 1. Subjects of protection and relief.

A federal court of equity will not enjoin an army officer, acting under orders of the war department and pursuant to an act of congress, from constructing a sewer from an army post, at suit of a landowner, who alleges that his property will be injured and depreciated in value.—*Sheriff v. Turner* (C. C.) 782.

A coal-selling corporation, having contracts with coal companies to take all their product at the mines and to transport and sell the same, obligating itself to pay for it at a stipulated price, less a commission, and which, in reliance thereon, had made contracts for the sale of the coal, *held* entitled to maintain a suit in its own right to enjoin third persons from unlawfully interfering with the performance of the contracts by the companies by intimidating their miners during a strike.—*Chesapeake & O. Coal Agency Co. v. Fire Creek Coal & Coke Co.* (C. C.) 942.

§ 2. Actions for injunctions.

In a suit in a federal court by a coal-selling corporation, having contracts for coal with coal companies, to enjoin third persons from unlawfully interfering with the performance of such contracts by the coal companies, the latter companies are proper parties defendant; but they cannot be aligned with plaintiff, to defeat the court's jurisdiction, where plaintiff sues to protect its own rights, and not in the right of such defendants.—*Chesapeake & O. Coal Agency Co. v. Fire Creek Coal & Coke Co.* (C. C.) 942.

§ 3. Preliminary and interlocutory injunctions.

An injunction to restrain defendants from cutting timber on lands in suit continued until final hearing.—*Kilgore v. Norman* (C. C.) 1006.

INSOLVENCY.

See "Bankruptcy."

Of building and loan association, see "Building and Loan Associations."

Of corporation, see "Corporations," § 5.

Of foreign corporation, see "Corporations," § 7.

INSPECTION.

Of writings, see "Discovery," § 2.

INSTRUCTIONS.

In civil actions, see "Trial," § 2.

INSURANCE.

§ 1. Control and regulation in general.

Under the Arkansas statute, requiring foreign insurance companies doing business in the state to designate an agent therein on whom process may be served, and providing that such

appointment shall be irrevocable (except that a new one may be substituted) so long as any liability of the company to any resident of the state continues, a company which enters the state to do business and complies with the statute is bound by its terms, and cannot withdraw from the state, and, by revoking the appointment of the agent so designated, prevent policy holders from suing it therein.—*Collier v. Mutual Reserve Fund Life Ass'n* (C. C.) 617.

§ 2. The contract in general.

A contract of life insurance *held* to be a Massachusetts contract under the facts alleged in the pleadings.—*Albro v. Manhattan Life Ins. Co.* (C. C.) 629.

The parties to a contract of life insurance, completed within a state between a resident thereof and a foreign company authorized to do business therein, cannot evade the effect of a statute declaring a rule of public policy with respect to such contracts made within its jurisdiction by providing in the policy that it shall be governed by the laws of another state.—*Albro v. Manhattan Life Ins. Co.* (C. C.) 629.

A copy of an application attached to a policy *held* not a "correct" copy, so as to entitle the application to admission in evidence, under the Massachusetts statute.—*Albro v. Manhattan Life Ins. Co.* (C. C.) 629.

§ 3. Risks and causes of loss.

An accident policy insuring only against injury resulting in "disability or death" construed and *held* not to require "immediate disability" following an accidental injury in order to render the insurer liable for the death of the insured, resulting within the prescribed time after the injury.—*Rorick v. Railway Officials' & Employees' Acc. Ass'n* (C. C. A.) 63.

§ 4. Extent of loss and liability of insurer.

Acts of the agent of a marine insurer in cooperating with the master of the insured vessel, after her injury and after the insurer had refused to accept an abandonment, in efforts to prevent further injury and to put the vessel in condition for permanent repair, *held* not to operate as an acceptance of the abandonment, but to have been without prejudice under the sue and labor clause of the policy.—*Soelberg v. Western Assur. Co.* (C. C. A.) 23; *Same v. Thames & Mersey Marine Ins. Co.*, Id.

Contracts of insurance made by a fraternal order with its members are subject to the same rules and principles that govern such contracts generally, and the rights of a member or his beneficiary thereunder will be protected by the courts against the wrongful or arbitrary action of the association.—*Supreme Council American Legion of Honor v. Orcutt* (C. C. A.) 682.

§ 5. Notice and proof of loss.

The fact that the insurer of a vessel demanded and accepted payment of a premium note after receiving notice of loss and of abandonment does not relieve the insured from the necessity of proving the loss to entitle him to recover on the policy.—*Soelberg v. Western*

Assur. Co. (C. C. A.) 23; Same v. Thames & Mersey Marine Ins. Co., Id.

Notice of an accident resulting in death held to have been given in time under the terms of an accident policy.—Rorick v. Railway Officials' & Employees' Acc. Ass'n (C. C. A.) 63.

§ 6. Actions on policies.

Cross-examination of plaintiff's witnesses in an action on a marine policy held proper.—Soelberg v. Western Assur. Co. (C. C. A.) 23; Same v. Thames & Mersey Marine Ins. Co., Id.

Evidence considered, in an action on a marine policy, and held insufficient to prove a loss from a cause and to an amount authorizing a recovery under the policy.—Soelberg v. Western Assur. Co. (C. C. A.) 23; Same v. Thames & Mersey Marine Ins. Co., Id.

§ 7. Mutual benefit insurance.

The suspension of a member of the order of Knights of Pythias for a violation of the laws of the order which occurred five years before charges were filed against him, during which time he continued to pay the assessments on his benefit certificate in the endowment rank, which were accepted, held not to work a forfeiture or suspension of his insurance.—Supreme Lodge Knights of Pythias v. Wellenvoss (C. C. A.) 671.

A fraternal order, which also issues insurance certificates upon the lives of members, as to such contracts is bound by the same rules that govern other insurance societies, and cannot forfeit a member's insurance for a violation of the laws of the order, where, after knowledge of such violation, it has continued to accept premiums from him.—Supreme Lodge Knights of Pythias v. Wellenvoss (C. C. A.) 671.

A fraternal order, which for two years accepted assessments from a member which were paid to an agent authorized by the head of the order to receive and forward the same, is estopped to repudiate the agency, and cannot lawfully suspend the member from his rights under his insurance because of the delay of such agent in forwarding an assessment which was paid to him in due time.—Supreme Council American Legion of Honor v. Orcutt (C. C. A.) 682.

Where a member of a fraternal order was wrongfully suspended, and thereafter received no notice of assessments due on his benefit certificate, his rights were not prejudiced by his failure to tender such assessments, nor waived by his making application for reinstatement.—Supreme Council American Legion of Honor v. Orcutt (C. C. A.) 682.

A petition on a benefit certificate in a fraternal order held to sufficiently allege the payment of all assessments by the insured.—Supreme Council American Legion of Honor v. Orcutt (C. C. A.) 682.

INTENT.

As element of trespass, see "Trespass," § 1.

INTEREST.

Element of damages, see "Damages," § 1. On funds in hands of receiver, see "Receivers," § 3.

§ 1. Rights and liabilities in general.

An agreement by a Colorado corporation to pay 8 per cent. interest on advances made in relation to its property in Nevada, in consideration of such advances and services to be rendered in connection therewith, held not usurious, although actually made in Pennsylvania, where such rate was greater than allowed by law.—Kroegher v. Calivada Colonization Co. (C. C. A.) 641; Calivada Colonization Co. v. Kroegher, Id.

INTERNAL REVENUE.

False personation of revenue officer, see "False Personation."

Subject and title of revenue law, see "Statutes," § 1.

The negligence of officers in failing to collect a tax on spirits at the proper time when the spirits were removed from the warehouse will not preclude the United States from recovering such tax in an action upon the distiller's bond, if it was properly chargeable.—United States v. Mullins (C. C. A.) 334.

Packages of distilled spirits, purchased by the United States while in a bonded warehouse and ordered withdrawn "free of tax" under the provisions of Rev. St. § 3464 [U. S. Comp. St. 1901, p. 2284], are thereby withdrawn entirely from the operation of the internal revenue laws, and the distiller cannot be charged with the tax on an alleged excess of shrinkage therein.—United States v. Mullins (C. C. A.) 334.

Act March 2, 1901 [U. S. Comp. St. 1901, p. 2304], amendatory of Act June 13, 1898 [page 2284], construed, and held not to impose an internal revenue tax on an administrator's bond, running to a state court.—McNally v. Field (C. C.) 445.

On an indictment against a common carrier for selling without license liquor carried into the state C. O. D., and delivered to the consignee, it was immaterial that no bill or invoices accompanied the shipment.—United States v. Adams Exp. Co. (D. C.) 240.

On an indictment against a common carrier for selling without license liquor carried into the state C. O. D. and delivered to the consignee, the "Commerce Clause" of the constitution was not involved; the only question being whether defendant sold the liquors.—United States v. Adams Exp. Co. (D. C.) 240.

The title to liquor delivered by a liquor company in another state to a common carrier to carry C. O. D. passed to the consignee on delivery to the carrier, and it was not guilty of selling the liquor.—United States v. Adams Exp. Co. (D. C.) 240.

Rev. St. § 3257 [U. S. Comp. St. 1901, p. 2112], punishing fraud by distillers on the in-

ternal revenue, construed in connection with 13 Stat. 223 et seq., etc., and *held* to include distillers of apple brandy.—United States v. Ridenour (D. C.) 411.

Rev. St. § 3257 [U. S. Comp. St. 1901, p. 2112], punishing frauds by distillers on the internal revenue, *held* not repealed by 19 Stat. 393 [page 2137], and 25 Stat. 560 [page 2141].—United States v. Ridenour (D. C.) 411.

Where a broker acted as agent for defendant in selling railroad stocks, and the broker executed a memorandum to the purchaser, duly stamped as required by Revenue Act March 2, 1901 (31 Stat. 943), defendant was not guilty of a violation of the statute by reason of its failure to execute a stamped memorandum of the sale to the broker.—United States v. Clawson (D. C.) 994.

INTERNATIONAL LAW.

International navigation rules, see "Collision," § 1.

INTERROGATORIES.

See "Equity," § 2.

INTERVENTION.

In attachment proceedings, see "Attachment," § 1.

INTOXICATING LIQUORS.

Internal revenue laws affecting, see "Internal Revenue."

INVENTION.

See "Patents."

ISSUES.

In civil actions, see "Equity," § 2.
In criminal prosecutions, see "Indictment and Information," § 2.

JOINT TENANCY.

See "Tenancy in Common."

JUDGES.

See "Courts."

§ 1. Rights, powers, duties, and liabilities.

A federal judge, on the return to a rule on a defendant in a foreclosure suit to show cause why a receiver should not be appointed and an injunction granted, cannot review the action of another judge sitting in the same court in appointing a temporary receiver and entering a restraining order pending the hearing on such rule.—H. B. Clafin Co. v. Furtick (C. C.) 429.

JUDGMENT.

Decisions of courts in general, see "Courts," § 1.

Decree in admiralty, see "Admiralty," § 3.

Decree in equity, see "Equity," § 5.

Enforcement by creditors' suit, see "Creditors' Suit."

Power to vacate judgment of state court after removal of cause to federal court, see "Removal of Causes," § 7.

Review, see "Appeal and Error."

§ 1. On trial of issues.

Judgment could not be rendered for the defendant notwithstanding the verdict, where the record showed that the issues joined were not immaterial.—Friedly v. Giddings (C. C.) 438.

§ 2. Collateral attack.

In attachment in a court of general jurisdiction, the making of the affidavit by the applicant for the writ before the sealing thereof *held* conclusively presumed.—Eltonhead v. Allen (C. C. A.) 126.

Recitals in the record of attachment proceedings *held* to show the making of the required affidavit by the applicant for the writ before the sealing thereof.—Eltonhead v. Allen (C. C. A.) 126.

§ 3. Merger and bar of causes of action and defenses.

An action by the receiver of a national bank against a stockholder to recover an assessment *held* not barred nor affected by a prior suit brought by the receiver to enforce a compromise agreement in which he took a voluntary nonsuit.—McClaine v. Rankin (C. C. A.) 110.

A decree foreclosing mortgages against the property of a corporation held by one of its directors, who purchased the same as its agent and at a discount, *held* not conclusive as to the amount due him from the corporation.—Kroegher v. Calivada Colonization Co. (C. C. A.) 641; Calivada Colonization Co. v. Kroegher, Id.

JURISDICTION.

Amount in controversy, see "Courts," § 5; "Removal of Causes," § 5.

Equity jurisdiction, see "Equity," § 1.

In bankruptcy proceedings, see "Bankruptcy," § 5.

Of habeas corpus proceedings, see "Habeas Corpus," § 1.

Of particular courts, see "Courts."

JURY.

Grounds for reference instead of trial by jury, see "Reference," § 1.

Instructions in civil actions, see "Trial," § 2.

LACHES.

In applying for reissue of patent, see "Patents," § 3.

In suing to cancel stock, see "Corporations," § 1.

LANDLORD AND TENANT.

Alteration of lease, see "Alteration of Instruments."

Demise of vessel, see "Shipping," § 1.

Leases by corporations, see "Corporations," § 4.

Mining leases, see "Mines and Minerals," § 2.

Railroad leases, see "Railroads," § 1.

§ 1. Leases and agreements in general.

Under the law of West Virginia, a person whose name is not mentioned in the body of a lease is not a party thereto nor bound thereby as a grantor, although he signs and acknowledges it as his deed.—*Barnsdall v. Boley* (C. C.) 191.

§ 2. Terms for years.

A stipulation in a lease against subletting, in the absence of some provision requiring it, will not be construed as a condition, but as a covenant, the breach of which will not work a forfeiture of the lease nor authorize a re-entry by the lessor.—*In re Pennewell* (C. C. A.) 139.

A covenant for renewal in a lease held void for uncertainty.—*Howe v. Larkin* (C. C.) 1005.

LANDS.

See "Public Lands."

LAW OF THE CASE.

Decision on appeal, see "Appeal and Error," § 6.

LEASES.

Oil leases, see "Mines and Minerals," § 2.

LETTERS PATENT.

For inventions, see "Patents."

For public lands, see "Mines and Minerals," § 1; "Public Lands," § 2.

LIBEL AND SLANDER.**§ 1. Actions.**

Damages, assessed at \$5,000, in action for libel, held excessive.—*Daisley v. Douglass* (C. C.) 485.

LICENSES.

For making, use, or sale of patented articles, see "Patents," § 5.

LIENS.

Effect of proceedings in bankruptcy, see "Bankruptcy," § 4.

Particular classes of liens.

See "Maritime Liens"; "Mechanics' Liens."

On vessel for negligent loss of cargo, see "Shipping," § 2.

LIFE ESTATES.

See "Curtesy."

LIFE INSURANCE.

See "Insurance," § 4.

LIMITATION.

Of claim of patent, see "Patents," § 4.

LIMITATION OF ACTIONS.

See "Adverse Possession."

For infringement of copyright, see "Copyrights," § 2.

§ 1. Pleading, evidence, trial, and review.

In an action at law for money had and received, to recover a sum paid on a transaction which was void, where limitation is not pleaded as a defense, the court is not authorized to direct a verdict for defendant on the ground that there was unreasonable delay in bringing the suit.—*Hallett v. New England Roller Grate Co.* (C. C. A.) 873.

LITERARY PROPERTY.

See "Copyrights."

A telegraph company, which gathers and distributes to its customers, by means of special wires and tickers, market quotations or other news, in which they have a peculiar interest and for which they pay, cannot be held to have thereby published the same in such sense as to entitle a competitor to copy such news from a customer's tape as fast as received, and distribute it to its own patrons; and such action constitutes unfair competition, against which a court of equity will grant relief.—*National Tel. News Co. v. Western Union Tel. Co.* (C. C. A.) 294.

A telegraph company has a property right in market quotations, which it obtains from an exchange, pays for, and transmits to its patrons, which entitles it to protection by injunction against unfair competition by others, who take such quotations from its wires or the offices of its patrons and sell or distribute the same.—*Illinois Commission Co. v. Cleveland Tel. Co.* (C. C. A.) 301.

LOAN COMPANIES.

See "Building and Loan Associations."

LOCAL PREJUDICE.

Ground for removal of cause, see "Removal of Causes," § 4.

LOCATION.

Of mining claim, see "Mines and Minerals," § 1.

MARINE INSURANCE.

See "Insurance," § 4.

MARITIME LIENS.

§ 1. Nature, grounds, and subject-matter in general.

Under the American admiralty law, a vessel is ordinarily liable for her repairs and supplies; but this liability rests upon the assent of the owner, actual or implied, and where he has refused to permit the vessel to be subjected to a lien, as by a provision in a charter, and such refusal is, or ought to be, known to the repairer or supply man, no lien arises, or it is deemed to be waived where it would otherwise exist.—The Underwriter (D. C.) 713.

Where a charter party required the charterer to furnish all coal for the vessel's use, and made the master his agent, no lien exists on the vessel for coal supplied on the master's order in a foreign port by one who knew of the charter and was put upon inquiry as to its terms, where it was not a port of distress and no actual necessity was shown for pledging the credit of the vessel.—The Underwriter (D. C.) 713.

MARKET QUOTATIONS.

As subject of copyright, see "Copyrights," § 1. Property rights in market quotations, see "Literary Property."

MASTER AND SERVANT.

§ 1. Master's liability for injuries to servant.

One employed as off bearer in a sawmill, his duty being to remove the hooks from the log or cant after it has been placed on the carriage, is not entitled to notice when the carriage is about to start, where it is uniformly started as soon as the hooks are removed, and he has been engaged at the work a sufficient length of time to know such fact.—Olsen v. North Pacific Lumber Co. (C. C. A.) 77.

An instruction in an action by a servant to recover for an injury *held* proper under the issues made by the pleadings and evidence.—Olsen v. North Pacific Lumber Co. (C. C. A.) 77.

The fact that a brakeman, killed while attempting to couple cars on a curve, was working from the inside of the curve, does not establish contributory negligence as matter of law, where there was evidence that in this particular case it was no more dangerous to couple from that side than from the other.—Northern Pac. Ry. Co. v. Tynan (C. C. A.) 288.

A brakeman has the right to rely on the performance by a railroad company of its duty to use reasonable care to see that its cars are in good order, and does not assume the risk arising from its failure to perform such duty.—Northern Pac. Ry. Co. v. Tynan (C. C. A.) 288.

A court *held*, under the evidence, to have properly refused to direct a verdict for defendant in an action against a railroad company for the death of a brakeman.—Northern Pac. Ry. Co. v. Tynan (C. C. A.) 288.

An employer who sets an employé at work at machinery *held* required to give him instructions for operating it in the way by which he will avoid injury.—Wright v. Stanley (C. C. A.) 330.

In an action for injuries to a boy while working at a planing machine, *held* for the jury whether he had assumed the risk.—Wright v. Stanley (C. C. A.) 330.

Instructions in an action for personal injuries *held* not objectionable, in that they made defendant an insurer of plaintiff's safety.—Wright v. Stanley (C. C. A.) 330.

A foreman of a workroom in a factory is not, by reason of such employment, a vice principal and representative of the employing corporation with respect to other workmen in such room.—Pistoner v. American Can Co. (C. C.) 496.

MASTERS IN CHANCERY.

See "Equity," § 4.

MAXIMS.

Of equity, see "Equity," § 1.

MECHANICS' LIENS.

§ 1. Operation and effect.

Under Acts Ark. 1895, p. 217, §§ 3, 10, the liens of a mortgage on buildings executed to secure money to erect them *held* superior to mechanics' and materialmen's liens only so far as the money was actually so expended.—Chauncey v. Dyke Bros. (C. C. A.) 1.

§ 2. Enforcement.

Under Acts Ark. 1895, p. 217, § 3, the proceeds of land on which a mortgage was a lien *held* to be properly applied *pro rata* to both that portion of the mortgage which was a lien on the improvements on the land superior to certain mechanics' liens and that portion which was inferior to such liens.—Chauncey v. Dyke Bros. (C. C. A.) 1.

The furnishing of material for a building on mortgaged premises, under the representation of the mortgagee's agent that he would pay for it out of money of the mortgagor retained for that purpose, *held* to constitute an assumption of the claim by the mortgagee.—Chauncey v. Dyke Bros. (C. C. A.) 1.

MINES AND MINERALS.

Alteration of oil lease, see "Alteration of Instruments."

§ 1. Public mineral lands.

Under St. Or. Oct. 14, 1898, providing for the recording of notices of the discovery and loca-

tion of mining claims, it is not essential to the validity of a location that the record should be a literal copy of the notice posted on the claim, but it is sufficient if it is a substantial copy.—Oregon King Min. Co. v. Brown (C. C. A.) 48.

Rev. St. § 2324 [U. S. Comp. St. 1901, p. 1426], does not require the boundaries of a mining location to be indicated on the ground by physical marks or monuments, but is complied with by any marking whereby the boundaries "can be readily traced," whether by stakes, mounds, monuments, or written notices.—Oregon King Min. Co. v. Brown (C. C. A.) 48.

A protest filed against the issuance of a patent to a mining claim after the application for the patent has been allowed, the purchase money paid, and a certificate of entry issued does not give the protestant any basis for a suit in equity to annul the patent issued after the protest has been dismissed, or to charge the patentee as a trustee of the legal title.—Neilson v. Champagne Min. & Mill. Co. (C. C. A.) 123.

A stranger cannot acquire any rights in a mining claim after the application of another for a patent therefor has been allowed, and he has paid for and received a certificate of entry, which vests in him the equitable title as against third parties.—Neilson v. Champagne Min. & Mill. Co. (C. C. A.) 123.

Certificates of location of mining claims are not conclusive evidence of the facts which they recite against parties who claim the land they describe adversely to their makers.—Uinta Tunnel Min. & Transp. Co. v. Creede & Cripple Creek Min. & Mill. Co. (C. C. A.) 164.

Entries and patents of lode mining claims, in proceedings to which a claimant of a tunnel site located across them prior to the entries was not, and was not required to be, a party, will not estop him from establishing the fact that no discoveries of lodges or mines of mineral had been made in the lode claims before the claim for the tunnel site was located across them.—Uinta Tunnel Min. & Transp. Co. v. Creede & Cripple Creek Min. & Mill. Co. (C. C. A.) 164.

Patents of lode claims based on entries made after the location of a claim for a tunnel site across them are subject to the rights of the claimants of the tunnel site where the rights were so uncertain and contingent that they could not be fairly litigated when the applications for the patents were made.—Uinta Tunnel Min. & Transp. Co. v. Creede & Cripple Creek Min. & Mill. Co. (C. C. A.) 164.

Rev. St. §§ 2325, 2326 [U. S. Comp. St. 1901, pp. 1429, 1430], do not require claimant of a tunnel site located across lode claims to file an adverse claim, when applications for patents of the lode claims are made, to protect his rights, where his interest is so uncertain that it cannot be fairly litigated when the applications are made.—Uinta Tunnel Min. & Transp. Co. v. Creede & Cripple Creek Min. & Mill. Co. (C. C. A.) 164.

§ 2. Title, conveyances, and contracts.

The lessee in an oil lease held to have forfeited his right to an extension of the term, under a provision that it should continue in force for 5 years, and as much longer "as oil or gas was found in paying quantities," by his failure to develop the property in good faith, where he drilled but one well during the 5 years, which, during the last part of the time, did not produce sufficient oil to pay for pumping.—Barnsdall v. Boley (C. C.) 191.

MISREPRESENTATION.

See "Fraud."

MOBS.

Liabilities of cities for injuries from mobs, see "Municipal Corporations," § 1.

MONEY RECEIVED.

Recovery of price paid for land, see "Vendor and Purchaser," § 1.

MONOPOLIES.

§ 1. Trusts and other combinations in restraint of trade.

That a complainant is a member of a combination in violation of the anti-trust law of July 2, 1890 [U. S. Comp. St. 1901, p. 3200], does not give third persons the right to infringe a patent of which complainant is owner, nor preclude complainant from maintaining a suit in equity to enjoin such infringement.—General Electric Co. v. Wise (C. C.) 922.

MORTGAGES.

Of personal property, see "Chattel Mortgages." Priority between mortgage and mechanic's lien, see "Mechanics' Liens," § 1. Subrogation to rights of mortgagee, see "Subrogation."

§ 1. Assignment of mortgage or debt.

Under the New Jersey statute, which makes an unrecorded mortgage void against a subsequent mortgage, taken for a valuable consideration and without notice, and first recorded, a purchaser of a mortgage having priority of record is entitled to rely on such fact, and is not chargeable with notice that a mortgage subsequently recorded is in fact prior in time, because it bears a prior date.—Coonrod v. Kelly (C. C. A.) 841.

The assignee of a mortgage takes all the rights of his assignor, and is not affected by notice of facts when he purchased which did not affect the mortgage in the hands of his assignor.—Coonrod v. Kelly (C. C. A.) 841.

§ 2. Foreclosure by action.

A mortgagee, who obtains the appointment of a receiver in a suit to foreclose, may properly be adjudged liable, on final settlement of the receiver's accounts, after the property has been sold, for a deficiency remaining in the

expenses of the receivership, where the proceeds of the property and its earnings were insufficient to pay the same.—*Chapman v. Atlantic Trust Co.* (C. C. A.) 257.

MULTIFARIOUSNESS.

See "Equity," § 2.

MUNICIPAL CORPORATIONS.

See "Counties."

§ 1. Torts.

A city may be held liable for the destruction or injury of property in consequence of a mob or riot therein, where such liability is imposed by statute; and it is no defense to an action for its enforcement that the city exercised all its power to prevent the loss, or that the state and federal governments were also engaged in protecting the property.—*City of Chicago v. Pennsylvania Co.* (C. C. A.) 497.

In an action against a city to recover for the destruction of property by a mob, a proclamation or other official acts of the mayor at the time are admissible to show a condition of riot then existing.—*City of Chicago v. Pennsylvania Co.* (C. C. A.) 497.

Evidence examined, and held to sustain the finding of a jury that property was destroyed in consequence of a mob during the railway strike of 1894 in Chicago, within the meaning of the Illinois statute, so as to render the city liable therefor.—*City of Chicago v. Pennsylvania Co.* (C. C. A.) 497.

§ 2. Fiscal management, public debt, securities, and taxation.

A proposed issue of bonds by an Iowa city held beyond its power, as creating an indebtedness in excess of that permitted by the state constitution.—*City of Ottumwa v. City Water Supply Co.* (C. C. A.) 315.

NAMES.

See "Trade-Marks and Trade-Names."

NATIONAL BANKS.

See "Banks and Banking," § 1.

NAVIGABLE WATERS.

As boundaries, see "Boundaries," § 1.

§ 1. Rights of public.

Under the statutes of Pennsylvania, the city of Philadelphia is not charged with the duty of removing vessels sinking in the channel way of the tide waters within the limits of the port; but such duty is imposed on the port warden, who is a state officer.—*McCaulley v. City of Philadelphia* (C. C. A.) 580.

Where the war department of the United States has taken charge of the removal of a sunken wreck in a navigable stream under authority of an act of congress, its jurisdiction

in the matter is exclusive, and a city cannot be held negligent in failing to take action for its removal.—*McCaulley v. City of Philadelphia* (C. C. A.) 580.

A city held not chargeable with negligence for failure to remove a sunken wreck from a navigable stream, where the owner was proceeding with due diligence in the effort to remove the same.—*McCaulley v. City of Philadelphia* (C. C. A.) 580.

§ 2. Riparian and littoral rights.

Accretions are apportionable among riparian proprietors according to the lateral lines of the firm land owned by them, and a legal title to such land is essential to support an action of ejectment to recover accretions thereto.—*Stockley v. Cissna* (C. C. A.) 812.

Land bounded by a navigable river, which is lost by erosion or submergence, is regained by the original owner of the fee when, by reliction or accretion, the water disappears and the land emerges.—*Stockley v. Cissna* (C. C. A.) 812.

NAVIGATION.

See "Navigable Waters," § 1.

Rules for preventing collisions, see "Collision," § 1.

NEGLIGENCE.

Causing collision, see "Collision."

Causing death, see "Death," § 1.

By particular classes of parties.

See "Carriers," § 1; "Municipal Corporations," § 1.

Employers, see "Master and Servant," § 1.

Railroad companies, see "Railroads," § 2.

Tugs, see "Towage."

Condition or use of particular species of property, works, or machinery.

See "Railroads," § 2.

Tug, see "Towage."

Contributory negligence.

Of person injured on railroad track, see "Railroads," § 2.

§ 1. Acts or omissions constituting negligence.

The manufacturer and seller of an article is liable for negligence in its manufacture only to the party with whom he contracts, unless it is an article in its nature dangerous and calculated to injure person or property.—*Standard Oil Co. v. Murray* (C. C. A.) 572.

§ 2. Actions.

Evidence held insufficient to warrant an inference of negligence in the manufacture of a petroleum lubricating oil from the fact that an explosion occurred in the room where it was kept; it appearing that gasoline was also used in the room.—*Standard Oil Co. v. Murray* (C. C. A.) 572.

In an action for damages from fire caused by electrical apparatus placed by defendants in

plaintiff's building, plaintiff must show some theory as to the precise manner in which the fire developed.—*Hawes v. Warren* (C. C.) 978.

In an action for damages from fire caused by electrical apparatus placed by defendant in plaintiff's building, the issue of negligence was properly submitted to the jury, though the evidence as to the precise manner in which the fire started was weak.—*Hawes v. Warren* (C. C.) 978.

NEGOTIABLE INSTRUMENTS.

See "Bills and Notes."

NEW TRIAL.

Misconduct of counsel ground for new trial, see "Trial," § 1.

§ 1. Grounds.

Where there is a conflict of testimony between unimpeached witnesses on an issue, it is the province of the jury to determine such issue, and the court is not authorized to set aside their verdict, although it may believe the preponderance of evidence to be the other way.—*Pringle v. Guild* (C. C.) 962.

NOTES.

Promissory notes, see "Bills and Notes."

NOTICE.

Of particular facts, acts, or proceedings.

Assessment of national bank shares, see "Taxation," § 2.

Loss insured against, see "Insurance," § 5.

Mining location, see "Mines and Minerals," § 1.

NOVELTY.

Of invention, see "Patents," § 1.

OBSTRUCTING JUSTICE.

An assault committed on a United States commissioner, by reason of his previous act in holding accused to a federal grand jury, held not an offense within Rev. St. § 5399 [U. S. Comp. St. 1901, p. 3656], prohibiting the intimidation of a United States officer in the discharge of his duty.—*United States v. McLeod* (C. C.) 416.

The fact that an assaulted United States commissioner does not hold a court of the United States, within Rev. St. § 5399 [U. S. Comp. St. 1901, p. 3656], does not prevent the assault from constituting an obstruction of justice in the federal circuit or district court, if it did so in fact.—*United States v. McLeod* (C. C.) 416.

Where a United States commissioner had held defendant to answer in a federal court, a subsequent assault by defendant on such commissioner was not an obstruction of justice

in any court of the United States, within Rev. St. § 5399 [U. S. Comp. St. 1901, p. 3656].—*United States v. McLeod* (C. C.) 416.

If an indictment for obstruction of justice by reason of an assault on a United States commissioner did not allege that the matter alleged to have been obstructed was pending in the federal circuit or district court at the time of the assault, it will be presumed to have been concluded.—*United States v. McLeod* (C. C.) 416.

OFFICERS.

False personation of officer, see "False Personation."

Injunctions affecting, see "Injunction," § 1.

Jurisdiction of suits by federal officers, see "Courts," § 3.

Resisting officer, see "Obstructing Justice."

Particular classes of officers.

See "Judges"; "Receivers"; "Sheriffs and Constables."

Corporate officers, see "Corporations," §§ 3, 4.

OILS.

See "Mines and Minerals," § 2.

OPINION EVIDENCE.

In civil actions, see "Evidence," § 6.

OPINIONS.

Of courts, see "Courts," § 1.

ORDERS.

Review of appealable orders, see "Appeal and Error."

PARTIES.

Joinder of parties to prevent removal of cause to federal court, see "Removal of Causes," § 3.

In particular actions or proceedings.

See "Admiralty," § 1; "Injunction," § 2.

Foreclosure, see "Chattel Mortgages," § 1.

On appeal or writ of error, see "Appeal and Error," §§ 2, 3.

To particular classes of conveyances, contracts, or transactions.

See "Contracts," § 2.

Leases, see "Landlord and Tenant," § 1.

§ 1. Plaintiffs.

The right of a complainant to maintain a suit is not affected by a contract constituting a third person its agent to prosecute and collect all claims against defendant for a per cent. of the amount recovered, even though such contract may have been champertous.—*New York Phonograph Co. v. National Phonograph Co.* (C. C.) 544.

PARTITION.

§ 1. Actions for partition.

On a bill for partition of land by the grantor of an undivided portion thereof, *held*, that claims by the grantee for moneys advanced for taxes on the whole, and claims by the grantor for expenses in defending a suit involving title to the whole, might all be adjusted.—*McClintock v. Fontaine* (C. C.) 448.

PATENTS.

For public lands, see "Mines and Minerals," § 1; "Public Lands," § 2.

Membership of plaintiff in unlawful combination to monopolize trade as defense to suit for infringement of patent, see "Monopolies," § 1.

§ 1. Patentability.

Patentable novelty must generally be conceded to the substitution of a new material for an old one in constructing an article, when such substitution accomplishes a result which those skilled in the art had long and vainly sought to effect, although the material used and its properties were known.—*George Frost Co. v. Cohn* (C. C. A.) 505.

The Gorton patent, No. 552,470, for a hose supporter, claim 1, *held* not anticipated, and to show patentable novelty.—*George Frost Co. v. Cohn* (C. C. A.) 505.

If the new use of an old process or device is so nearly analogous to the former ones that its applicability would occur to a person of ordinary mechanical skill, it is only a case of double use, not involving invention.—*Johnson Co. v. Toledo Traction Co.* (C. C. A.) 885.

Patents are valid only when granted for a mechanically novel structure which involves invention, and not merely for an old thing in a better shape, or of better material, or having its utility due to mechanical skill in adapting what was old.—*Farmers' Mfg. Co. v. Spruiks Mfg. Co.* (C. C.) 594.

A mechanical equivalent must be adaptable to use as a substitute for something else, and competent to perform the functions of a particular device for which it may be substituted.—*Alaska Packers' Ass'n v. Letson* (C. C.) 599.

A patent for an invention which successfully accomplishes a useful result is not void for anticipation or prior use because of a prior device which was inoperative.—*General Electric Co. v. Wise* (C. C.) 922.

§ 2. Requisites and validity of letters patent.

Intervener in patent suit against one selling goods manufactured by him *held* controlled by an estoppel operating against the original defendant in the suit.—*Consolidated Rubber Tire Co. v. Finley Rubber Tire Co.* (C. C.) 705.

§ 3. Reissues.

A delay of more than 5 years before applying for a reissue on the ground of inadvertence, accident, or mistake invalidates the reissue, unless excused by special circumstances.

—*United Blue Flame Oil Stove Co. v. Glazier* (C. C. A.) 157.

§ 4. Construction and operation of letters patent.

When the language of a claim of a patent is clear and distinct, the patentee cannot claim anything beyond for the purpose of establishing infringement.—*Westinghouse Air Brake Co. v. New York Air Brake Co.* (C. C. A.) 874.

If the structures described in prior patents do not themselves anticipate that of a later patent, the descriptions of them in the specifications cannot be *held* to anticipate.—*Weston Electrical Instrument Co. v. Stevens* (C. C.) 181.

An element or feature added to a claim of a patent by amendment to meet objections of the patent office in order to obtain a patent must be held essential in a suit for infringement.—*Ludington Novelty Co. v. Leonard* (C. C.) 937; *Same v. Fischer*, *Id.*

§ 5. Title, conveyances, and contracts.

Under an agreement by the assignor of a patent to pay the patentee a stipulated sum, each year, so long as the patent should continue in force and valid, "as an annuity," the right to the payments does not cease on the death of the assignor; but they may be enforced by his legal representatives so long as the patent remains in force.—*Goodyear Shoe Machinery Co. v. Dancel* (C. C. A.) 692.

It must clearly and certainly appear from the opinion of the circuit court of appeals in an infringement suit that the court held the patent void, before such decision can be availed of as matter of law to defeat an action to recover royalties from a licensee under such patent.—*Sherbourne v. Willcox & Gibbs Sewing Mach. Co.* (C. C.) 371.

Contract for sale of patented articles *held* not to show that the term of the contract contemplated by the parties was the term of the patent.—*Kenny v. Knight* (C. C.) 475.

§ 6. Infringement.

The fact that the device of a patent was the first to accomplish a certain result does not render another an infringement merely because it accomplishes the same result, but it must do so by substantially the same or similar means.—*Massey v. Larkins* (C. C. A.) 171.

The combination of an alleged infringing device is not that of the patent merely because it will do the same work in one of the several operations it is designed to effect in substantially the same way.—*Westinghouse Air Brake Co. v. New York Air Brake Co.* (C. C. A.) 874.

A bill *held* to state a cause of action for an injunction and accounting, and an adjudication of the invalidity of a patent obtained by defendant, on the ground that complainant was the real inventor, and was induced by false promises to disclose the invention to defendant.—*Murjahn v. Hall* (C. C.) 186.

Where defendant has not denied under oath the making and selling of the articles offered in evidence by complainant to prove infringe

ment, evidence which establishes a strong probability of such fact is sufficient to make a prima facie case.—Hutter v. De Q. Bottle Stopper Co. (C. C.) 190.

One who makes and sells a part of a structure, adapted to be completed, which, when so completed, is an infringement of a patent, and until such completion is inoperative and of no commercial value, is a contributory infringer.—Bishop & Babcock Co. v. Levine (C. C.) 363.

A court may properly give a certificate that an abandoned application for a patent will be admitted in evidence in a suit in equity, without regard to its materiality or relevancy, if such certificate is required by the patent office as a prerequisite to the production or certification of the document or a copy thereof.—Mac-William v. Connecticut Web Co. (C. C.) 509.

Officers of a corporation are not liable in equity for infringement of a patent by the corporation, where they are not charged with having participated in the infringement otherwise than as officers of the corporation.—Farmers Mfg. Co. v. Spruks Mfg. Co. (C. C.) 594.

That a defendant is able to respond in damages is no defense to an application for an injunction against infringement of a patent.—General Electric Co. v. Wise (C. C.) 922.

PATENTS ENUMERATED.

ENGLISH.

1883.

- 5,902. Process for making plush..... 357
- 5,904. Process for making plush..... 357

1887.

- 225. Movable coil conductor..... 184
- 18,016. Process for making plush..... 357

1892.

- 8,547. Process for making plush..... 357

1902.

- 13,890. Elevator controlling mechanism.. 936

UNITED STATES.

DESIGN.

- 25,435. Bottle stopper 190

ORIGINAL.

- 337. Railway switch 888
- 24,723. Ventilating barrel 596
- 29,775. Game-board 937
- 44,548. Oil stove 157, 164
- 55,033. Oil stove 157, 164
- 60,224. Oil stove 157, 164
- 61,577. Ore roasting furnace..... 918
- 73,352. Ventilating barrel 596
- 110,399. Paper tube 189
- 131,896. Elevator controlling mechanism.. 930
- 134,273. Elevator controlling mechanism.. 931
- 158,613. Elevator controlling mechanism.. 930
- 181,447. Sectional book case 699
- 203,016. Carbon transmitter 901
- 220,163. Sectional book case 699
- 222,652. Microphones 911
- 224,573. Microphones 911
- 227,818. Ore roasting furnace..... 918
- 259,710. Engineer's valve for controlling air brake 874

- 266,783. Trimming attachment for sewing machine 367-369
- 293,192. Cash carrier 615
- 307,942. Pleasure railway 359
- 309,699. Trimmer for sewing machine.... 369
- 317,202. Elevator controlling mechanism.. 930
- 324,818. Trimming attachment for sewing machine 367
- 334,166. Oil stove 163
- 335,239. Elevator controlling mechanism.. 931
- 341,790. Trimmers 371
- 349,175. Elevator controlling mechanism.. 931
- 357,851. Cash carrier 614, 615
- 359,551. Elevator controlling mechanism.. 928, 931-936
- 361,934. Oil stove 157, 158
- 367,252. Pleasure railway 359
- 372,358. Movable coil conductor..... 184
- 374,133. Paper tube 189
- 376,804. Can-heading machine 599
- 382,288. Hair clipping machine..... 358
- 390,053. Elevator controlling mechanism.. 931
- 401,916. Engineer's valve for controlling air brake 874
- 417,218. Ventilating barrel 596
- 420,021. Ventilating barrel 594, 597, 599
- 424,314. Knitting machine 921
- 430,328. Electric motor 178
- 433,637. Voltmeter 181
- 439,166. Deep well packer..... 171
- 441,846. Paper tube 188, 189
- 444,233. Paper tube 188, 189
- 453,955. Elevator controlling mechanism.. 928, 929
- 456,463. Elevator controlling mechanism.. 932, 933
- 459,036. Sewing machine 693
- 463,569. Telephone transmitter 893
- 463,629. Oil stove 157
- 469,809. Electrical converter 365
- 469,984. Elevator controlling mechanism.. 931
- 470,340. Movable coil conductor..... 181, 185
- 471,264. Ore-roasting furnace 918
- 474,230. Cylinder transmitter 900
- 474,231. Cylinder transmitter 900
- 491,113. Bottle stopper 190
- 492,909. Refrigerator door 699
- 504,290. Engineer's valve for controlling air brake 874, 879
- 518,305. Vapor burner 157
- 532,013. Ore roasting furnace..... 918
- 536,734. Railway switch 885
- 537,434. Liquor cabinet 363
- 540,796. Railway switch 885, 890
- 552,470. Hose supporter 505
- 557,737. Sectional book case..... 696, 697
- 559,232. Incandescent lamp socket..... 922, 924, 925
- 567,592. Paint composition 187
- 602,179. Game-board 937, 938
- 603,619. Paper decoration 372
- 605,710. Process for making plush..... 355
- 629,574. Can-heading machine 599
- 666,742. Game-board 937, 938

REISSUE.

- 6,044. Ventilating barrel 595
- 7,289. Ventilating barrel 595
- 11,250. Voltmeter 181
- 11,575. Oil stove 164
- 11,592. Vapor burner 157, 158
- 11,601. Oil stove 157, 158, 164
- 11,607. Oil stove 157, 158, 164

PAYMENT.

By bankrupt as preferences, see "Bankruptcy," § 4.
Of duties, see "Customs Duties," § 4.
Subrogation on payment, see "Subrogation."

PERSONAL INJURIES.

See "Negligence."
To employe, see "Master and Servant," § 1.
To person on or near railroad tracks, see "Railroads," § 2.

PETITION.

In bankruptcy, see "Bankruptcy," § 1.

PHOTOGRAPHS.

As subject of copyright, see "Copyrights," § 1.

PLATS.

As evidence, see "Evidence," § 3.

PLEADING.

Allegations as to particular facts, acts, or transactions.

Statute of limitations, see "Limitation of Actions," § 1.

In actions by or against particular classes of parties.

Stockholders, see "Banks and Banking," § 1; "Corporations," § 2.

In particular actions or proceedings.

See "Admiralty," § 2; "Equity," § 2.

For appointment of receiver, see "Receivers," § 1.

For cancellation of stock, see "Corporations," § 1.

For causing death, see "Death," § 1.

For customs duties, see "Customs Duties," § 4.

For infringement of copyright, see "Copyrights," § 2.

For infringement of patent, see "Patents," § 6.

Indictment or criminal information or complaint, see "Indictment and Information."

On benefit insurance certificate, see "Insurance," § 7.

To establish or enforce trust, see "Trusts," § 1.
To recover land taken for public use, see "Eminent Domain," § 2.

§ 1. Demurrer or exception.

Demurrer to a complaint in action on contract *held* not to raise the question whether the damages specifically claimed are such as are recoverable for breach of the contract declared on.—Kenny v. Knight (C. C.) 475.

§ 2. Amended and supplemental pleadings and replacer.

An amended complaint which is complete in itself becomes the sole statement of the plain-

119 F.—67

tiff's cause of action.—United States v. Gentry (C. C. A.) 70.

Under the rule in South Carolina, a complaint cannot be amended by adding allegations to show a liability on the part of a defendant against whom no cause of action is stated in the original complaint.—Coker v. Monaghan Mills (C. C.) 706.

The complaint in an action for breach of a contract by the failure of defendant to pay an installment due thereunder, there being other obligations not matured, may be amended to ask damages for breach of the entire contract, where the amendment shows the contract to have been executory, and alleges that prior to the suit defendant had repudiated the same and refused to be bound thereby.—Northrop v. Mercantile Trust & Deposit Co. (C. C.) 969.

Under the Code of Procedure of South Carolina, the complaint in an action for a breach of a contract cannot be amended by alleging a second breach occurring after the action was commenced, and asking damages also for that.—Northrop v. Mercantile Trust & Deposit Co. (C. C.) 969.

POLICY.

Of insurance, see "Insurance."

POLITICAL RIGHTS.

Suffrage, see "Elections."

POSSESSION.

See "Adverse Possession."

POST OFFICE.**§ 1. Post-office department, post offices, postmasters, and other officers.**

Under Act May 24, 1888 [U. S. Comp. St. 1901, p. 2637], a letter carrier *held* not entitled to extra compensation.—United States v. McCrory (C. C. A.) 861.

§ 2. Offenses against postal laws.

An indictment under Rev. St. § 5480 [U. S. Comp. St. 1901, p. 3696], based on the use of the mails by defendants to induce persons to come to a certain place for the purpose of there defrauding them, *held* bad for uncertainty.—Stewart v. United States (C. C. A.) 89.

A count in an indictment for using mails to defraud, under Rev. St. § 5480 [U. S. Comp. St. 1901, p. 3696], *held* insufficient.—Stewart v. United States (C. C. A.) 89.

An indictment for using the mails to defraud, under Rev. St. § 5480 [U. S. Comp. St. 1901, p. 3696], found in the district of Kansas, *held* to show that the offense, if any, was committed in Missouri.—Stewart v. United States (C. C. A.) 89.

An indictment for using the mails to defraud, under Rev. St. § 5480 [U. S. Comp. St. 1901, p. 3696], must describe defendants fraudulent scheme.—Stewart v. United States (C. C. A.) 89.

An indictment under Rev. St. § 5480 [U. S. Comp. St. 1901, p. 3696], must allege that defendants devised a fraudulent scheme, to be effected by use of the mails, and that they either deposited in or took from the mails a letter in pursuance of the scheme.—*Stewart v. United States* (C. C. A.) 89.

PRACTICE.

Adoption by United States courts of practice of state courts, see "Courts," § 6.
Procedure of particular courts, see "Courts."

In particular civil actions or proceedings.

See "Habeas Corpus," § 1.

Particular proceedings in actions.

See "Costs"; "Evidence"; "Judgment"; "Limitation of Actions"; "Parties"; "Pleading"; "Reference"; "Removal of Causes"; "Stipulations"; "Trial."

Particular remedies in or incident to actions.

See "Attachment"; "Discovery"; "Injunction"; "Receivers."

Procedure in exercise of special jurisdictions.
In admiralty, see "Admiralty"; "Collision," § 9.

In bankruptcy, see "Bankruptcy," § 1.
In equity, see "Equity."

Procedure on review.

See "Appeal and Error."

PREFERENCES.

Effect of proceedings in bankruptcy, see "Bankruptcy," § 4.

PREJUDICE.

Ground for removal of cause, see "Removal of Causes," § 4.
Ground for reversal in civil actions, see "Appeal and Error," § 6.

PRESUMPTIONS.

On appeal or error, see "Appeal and Error," § 6.

PRINCIPAL AND AGENT.

Right of insurance company to revoke appointment of agent to receive service of process, see "Insurance," § 1.

PRINCIPAL AND SURETY.

Liabilities of sureties on bonds in legal proceedings, see "Appeal and Error," § 8; "Attachment," § 2.

PRIORITIES.

Of mechanics' liens, see "Mechanics' Liens," § 1.

PRIZE.

Of war, see "War."

PROCESS.

See "Injunction."

In action against foreign corporations, see "Corporations," § 7.

In admiralty, see "Admiralty," § 1.

PROMISSORY NOTES.

See "Bills and Notes."

PROOF.

Of loss insured against, see "Insurance," § 5.

PROPERTY.

See "Copyrights"; "Fixtures"; "Literary Property"; "Mines and Minerals"; "Shipping"; "Trade-Marks and Trade-Names."

Adverse possession, see "Adverse Possession."
Passing to trustee in bankruptcy, see "Bankruptcy," § 3.

Taking for public use, see "Eminent Domain."

PUBLIC DEBT.

See "Counties," § 1; "Municipal Corporations," § 2.

PUBLIC LANDS.

Indian lands, see "Indians."

Mineral lands, see "Mines and Minerals," § 1.

§ 1. Government ownership.

The rule is that one who takes timber from a public domain is a willful trespasser, and a full compliance with the requirements of Act June 3, 1878 [U. S. Comp. St. 1901, p. 1528], and the rules prescribed by the secretary of the interior thereunder, is essential to justify the taking under such act.—*United States v. Gentry* (C. C. A.) 70.

The rule of the secretary of the interior that one who takes timber from the mineral land of the United States, under Act June 3, 1878 [U. S. Comp. St. 1901, p. 1528], shall not sell it without taking a written agreement from the purchaser, requires the vendor to take the agreement at the time of the sale.—*United States v. Gentry* (C. C. A.) 70.

The United States may maintain an action to recover the value of timber cut from unsurveyed mineral lands to which its title has not been divested, notwithstanding the locating of mining claims thereon by third parties.—*Powers v. United States* (C. C. A.) 562.

To subject one who unlawfully cuts and removes timber from public lands to liability for the enhanced value given to it by his labor and expense, his trespass must have been will-

ful, with knowledge that he acted without right.—*Powers v. United States* (C. C. A.) 562.

§ 2. Survey and disposal of lands of United States.

Under section 8 of Act May 17, 1884 (23 Stat. 24), creating a land district in Alaska, prior occupants of tide lands for fishing purposes are entitled to protection in such occupancy and use, undisturbed by others claiming a common right to fish thereon.—*Heckman v. Sutter* (C. C. A.) 88.

Judgments of the land department, permitting entries of land and the patents based thereon, bind all the parties to the proceedings, but do not estop those who were not, and were not required to be, parties, from establishing the truth as to any facts material to their claims in any litigation between them and the holders under the patents.—*Uinta Tunnel Min. & Transp. Co. v. Creede & Cripple Creek Mining & Milling Co.* (C. C. A.) 164.

§ 3. Disposal of lands of the states.

Though a survey of state lands in Texas preliminary to patent may have been irregular, the patent *held* not void.—*Witherspoon v. Olcott* (C. C. A.) 175.

Evidence in trespass to try title *held* not to show prior patent to lands in controversy.—*Witherspoon v. Olcott* (C. C. A.) 175.

A grant of land by the state of Tennessee relates back to the date of entry, and is sufficient to support an action of ejectment for the land granted, although such action was commenced before the date of the grant, where the entry was prior to the action.—*Stockley v. Cissna* (C. C. A.) 812.

Acts Tenn. 1847, c. 20, providing for the granting by the state of vacant lands, does not apply to land created many years afterward by a sudden change in the channel of the Mississippi river, by which the abandoned channel became dry land; but the title to such land remains in the state for public purposes, and cannot be conveyed to private owners, unless specially authorized by the legislature.—*Stockley v. Cissna* (C. C. A.) 812.

PUBLIC USE.

Taking property for public use, see "Eminent Domain."

QUOTATIONS.

Market quotations as subject of copyright, see "Copyrights."

Property rights in market quotations, see "Literary Property."

RAILROADS.

As employers, see "Master and Servant."

Carriage of goods and passengers, see "Carriers."

§ 1. Sales, leases, traffic contracts, and consolidation.

An application of lessor of a railroad to be made a party to a suit in a federal court will

be denied, where the applicant is not an indispensable party and the application is made for the purpose of ousting the jurisdiction of the court.—*Baltimore & O. R. Co. v. Wabash R. Co.* (C. C. A.) 678.

§ 2. Operation.

The driver of a team who, after crossing a side track filled with box cars, which obstructed the view, drove upon the main track of a railroad 50 feet distant without looking or listening for a train, was guilty of negligence as matter of law.—*Hines v. Texas & P. Ry. Co.* (C. C. A.) 157.

RATIFICATION.

Of acts of corporate officers, see "Corporations," § 4.

REAL ACTIONS.

See "Ejectment."

RECEIVERS.

In action to foreclose mortgage, see "Chattel Mortgages," § 1.

Of corporations in general, see "Corporations," § 5.

Of foreign corporations, see "Corporations," § 7.

§ 1. Appointment, qualification, and tenure.

That an amended bill for the appointment of a receiver was not verified did not render such appointment void, where no objection on such ground was taken at the time.—*Clark v. Brown* (C. C. A.) 130.

An answer to a bill for the appointment of a receiver *held* not sufficient to prevent the appointment.—*Clark v. Brown* (C. C. A.) 130.

Bill construed and *held* to authorize the appointment of a receiver to care for and sell a crop in the hands of defendant.—*Clark v. Brown* (C. C. A.) 130.

Where the validity of the appointment of a receiver depends on the sufficiency of a bill, an order appointing such receiver, though erroneous, is not void.—*Clark v. Brown* (C. C. A.) 130.

§ 2. Title to and possession of property.

A vessel in the actual possession of receivers appointed by a circuit court is not subject to seizure on process from the district court for the same district in a suit in rem to enforce a demand which arose prior to the receivership, unless by permission of the circuit court.—*The Jonas H. French* (D. C.) 462.

§ 3. Management and disposition of property.

Defendant *held* not entitled to recover from complainant interest on funds in the hands of a receiver erroneously appointed at complainant's instance.—*Clark v. Brown* (C. C. A.) 130.

§ 4. Accounting and compensation.

Where the appointment of a receiver was acquiesced in by defendant, and the receiver was

efficient, his compensation should be paid from the proceeds of the property sold, though his appointment was erroneous.—*Clark v. Brown* (C. C. A.) 130.

§ 5. Foreign and ancillary receiverships.

The modern tendency of the courts is toward a liberal policy, which recognizes a receiver's right to possession of the property embraced in the decree appointing him, although situated without the territorial jurisdiction of the court making the appointment.—*Lewis v. American Naval Stores Co.* (C. C.) 391; *Hibernia Bank & Trust Co. v. Lewis*, *Id.*

RECORDS.

Of notice of mining location, see "Mines and Minerals," § 1.
Transcript on appeal or writ of error, see "Appeal and Error," § 4.

REFERENCE.

See "Arbitration and Award."
To master or commissioner in equity, see "Equity," § 4.

§ 1. Nature, grounds, and order of reference.

A federal court has inherent power to appoint an auditor in an action at law, where necessary to simplify the issues, so they can be properly understood by a jury; and, where the state practice cannot be followed, the court may, in its discretion, direct the expense to be borne by either or both parties, as justice may require.—*Fenno v. Primrose* (C. C. A.) 80L.

REHEARING.

See "New Trial."

REISSUE.

Of patent, see "Patents," § 3.

RELICITION.

See "Navigable Waters," § 2.

REMAND.

Of cause removed from state court, see "Removal of Causes," § 6.

REMISSION.

Affirmance on remission of excessive damages, see "Appeal and Error," § 7.

REMOVAL OF CAUSES.

§ 1. Power to remove and right of removal in general.

The appearance of a defendant in a state court to file a petition and bond for removal

is special, and is not a waiver of the right to object to the jurisdiction of the state court over him.—*Cady v. Associated Colonies* (C. C.) 420.

§ 2. Origin, nature, and subject of controversy.

A quo warranto proceeding by the state of California to test the right of an organization to exercise the franchises and functions of an irrigation district under the laws of the state held not removable, as one arising under the constitution of the United States, because of incidental allegations in the information charging that the acts of defendant were in violation of constitutional provisions.—*People v. Brown's Valley Irr. Dist.* (C. C.) 535.

A criminal prosecution for an assault by defendant in repelling an attack made upon him while acting as a posseman under appointment by a deputy United States marshal, and assisting in an attempt to find and arrest a person charged with a violation of the revenue laws, is removable into the federal court, under Rev. St. § 643 [U. S. Comp. St. 1901, p. 521].—*Commonwealth of Virginia v. De Hart* (C. C.) 626.

§ 3. Citizenship or alienage of parties.

A prayer inter alia for relief against one of several defendants alone does not create a separate controversy with such defendant where there are no averments in the bill upon which such relief could be based.—*MacGinniss v. Boston & M. Consol. Copper & Silver Min. Co.* (C. C. A.) 96.

Where the relief sought against one of several defendants is merely incidental to the principal purpose of the suit, the fact that such incidental relief pertains to one only of the defendants does not make it a separable controversy so as to give such defendant the right of removal.—*MacGinniss v. Boston & M. Consol. Copper & Silver Min. Co.* (C. C. A.) 96.

A suit by a stockholder against the corporation and another, to enjoin the carrying out of an alleged conspiracy between the defendants, is not one in which the corporation is a party in the same interest with complainant; and they cannot be aligned together for the purpose of giving the other defendant the right of removal on the ground of diversity of citizenship.—*MacGinniss v. Boston & M. Consol. Copper & Silver Min. Co.* (C. C. A.) 96.

A suit by a stockholder against the corporation and a foreign corporation to enjoin the latter from obtaining and exercising control over the property and stock of the former does not involve a separate controversy between complainant and the foreign corporation, which gives the latter the right of removal.—*MacGinniss v. Boston & M. Consol. Copper & Silver Min. Co.* (C. C. A.) 96.

A proceeding by a railroad company to condemn right of way under the statutes of Missouri is removable where it involves a controversy between citizens of different states and the requisite amount is in dispute.—*Union Terminal Ry. Co. v. Chicago, B. & Q. R. Co.* (C. C.) 209.

Evidence considered and *held* to establish as matter of law that a railroad company, in proceedings to condemn right of way, joined a local corporation as defendant, together with one of another state, for the purpose of preventing a removal of the cause by the latter.—Union Terminal Ry. Co. v. Chicago B. & Q. R. Co. (C. C.) 209.

Where a petition in a state court alleges a joint cause of action against a resident and a nonresident defendant, the cause is not removable on petition of the nonresident unless he both alleges and proves to the satisfaction of the court that the local defendant was joined for the fraudulent purpose of preventing a removal.—Union Terminal Ry. Co. v. Chicago, B. & Q. R. Co. (C. C.) 209.

In a stockholder's suit against the corporation and certain of its officers, *held*, that there was no controversy between complainants and the corporation which entitled the latter to a removal on the ground that it was a nonresident and that there was a separable controversy.—Campbell v. Milliken (C. C.) 981.

§ 4. Prejudice, local influence, or denial of civil rights.

One of two defendants, both necessary parties to the suit, where there is no separable controversy, cannot remove the cause on the ground of prejudice or local influence, under the fourth subdivision of section 2 of the judiciary act of 1887-88, where his codefendant is a citizen of the same state as the plaintiffs.—Campbell v. Milliken (C. C.) 982.

§ 5. Amount or value in controversy.

In a suit to enjoin a permanent injury to land, the value of the land determines the amount in controversy for the purposes of the jurisdiction of a federal court; and if such value exceeds \$2,000, and other jurisdictional facts appear, the cause is removable.—Sheriff v. Turner (C. C.) 231.

§ 6. Remand or dismissal of cause.

Where a cause has been properly removed into a federal court, that court cannot remand it for the purpose of having a motion to vacate a default judgment rendered against defendant before the removal determined by the state court.—Cady v. Associated Colonies (C. C.) 420.

§ 7. Proceedings in cause after removal.

Where, at the time a cause was removed into a federal court, a judgment had been rendered against the defendant, but the state court had power under the statute to vacate the same, the federal court was vested, on the removal, with the same power.—Cady v. Associated Colonies (C. C.) 420.

RENEWAL.

Of lease, see "Landlord and Tenant," § 2.

REQUESTS.

For instructions to jury in civil actions, see "Trial," § 2.

RESCISSION.

Of contract, see "Contracts," § 3.

RES JUDICATA.

See "Judgment," § 3.

RESTRAINT OF TRADE.

Trusts and other combinations, see "Monopolies," § 1.

REVENUE.

See "Internal Revenue"; "Taxation"; "Customs Duties."

REVIEW.

See "Appeal and Error."

Bill in equity, see "Equity," § 6.

REVOCATION.

Of agreement for arbitration, see "Arbitration and Award," § 1.

REVOLT.

By seamen, see "Seamen."

RIOT.

Liabilities of cities for injuries from riots, see "Municipal Corporations," § 1.

RIPARIAN RIGHTS.

See "Navigable Waters," § 2.

RISKS.

Assumed by employé, see "Master and Servant," § 1.

Within insurance policy, see "Insurance," § 3.

RULES OF NAVIGATION.

See "Collision," § 1.

SALES.

Of property of bankrupt, see "Bankruptcy," § 5.

Of public lands, see "Public Lands," § 2.

Right of person injured by explosion of oil purchased by employer to recover on ground of defect in quality of oil, see "Contracts," § 2.

§ 1. Requisites and validity of contract.

Facts *held* not to constitute an unconditional acceptance of an offer to sell cotton, so as to consummate a contract of sale and charge the seller for failure to deliver.—China & Japan Trading Co. v. Davis (C. C. A.) 688.

§ 2. Remedies of seller.

Evidence *held* sufficient to warrant a finding that a part of the materials ordered, and for the nondelivery of which the buyer claimed damages by way of counterclaim, were, when ordered, intended for a third party.—Trinidad Asphalt Mfg. Co. v. Trinidad Asphalt Refining Co. (C. C. A.) 134.

On counterclaim for damages for refusal to fill orders for materials under a contract, admission in evidence of a contract between the buyer and a third party *held* proper.—Trinidad Asphalt Mfg. Co. v. Trinidad Asphalt Refining Co. (C. C. A.) 134.

On counterclaim for damages for refusal to deliver materials under a contract, question asked witness if he did not know when he made a contract with a third party that the buyer's contract had about expired *held* proper.—Trinidad Asphalt Mfg. Co. v. Trinidad Asphalt Refining Co. (C. C. A.) 134.

On counterclaim for damages for refusal to fill orders for asphalt and cement under a contract, the question whether the seller knew that the buyer was handling other asphalts *held* to call for irrelevant testimony.—Trinidad Asphalt Mfg. Co. v. Trinidad Asphalt Refining Co. (C. C. A.) 134.

The fact that a seller was anxious to be relieved from a contract requiring it to sell materials did not furnish the buyer an excuse for committing a breach of the stipulation binding it to use the materials so purchased exclusively in its own trade.—Trinidad Asphalt Mfg. Co. v. Trinidad Asphalt Refining Co. (C. C. A.) 134.

A buyer bound by the contract to use the materials purchased exclusively in its own trade *held* not entitled to damages for the seller's failure to fill orders for materials intended in whole or in part for delivery to third parties.—Trinidad Asphalt Mfg. Co. v. Trinidad Asphalt Refining Co. (C. C. A.) 134.

§ 3. Remedies of buyer.

The measure of damages for breach of contract to furnish machinery, which is accepted by the vendee in ignorance that it fails to comply with the agreement, is the difference between its value if it had complied with the contract and its value in its defective condition.—Florence Oil & Refining Co. v. Farrar (C. C. A.) 150.

SALVAGE.**§ 1. Right to compensation.**

The owners of a tug which was in fault for the sinking of a barge are not entitled to recover for raising the same as a salvage service, although they subsequently obtained a limitation of their liability for the loss.—The Pine Forest (D. C.) 999.

SEAMEN.

The provision of Rev. St. § 5359 [U. S. Comp. St. 1901, p. 3639], making it a criminal offense for a seaman to "endeavor to make a revolt," was not repealed by implication by

the shipping commissioners' act of June 7, 1872, Rev. St. § 4596, par. 7 [U. S. Comp. St. 1901, pp. 3113, 3115].—In re Simpson (D. C.) 620.

SECONDARY EVIDENCE.

In civil actions, see "Evidence," § 3.

SEPARABLE CONTROVERSY.

Removal from state court, see "Removal of Causes," § 3.

SET-OFF AND COUNTERCLAIM.

Set-off of benefits against damages to property taken for public use, see "Eminent Domain," § 1.

§ 1. Subject-matter.

One of two joint makers of a note when sued alone thereon may plead as a counterclaim a breach of warranty in respect to machinery for the purchase price of which the note was given, and which was sold by the plaintiff to the makers of the note jointly.—York Mfg. Co. v. Rothwell (C. C. A.) 144.

Defendant *held* not entitled to set off claim due from plaintiff to his deceased wife, which he could recover only in course of administration on the wife's estate, against a claim against him personally.—Richter v. Hanne-man (C. C.) 471.

SHERIFFS AND CONSTABLES.**§ 1. Powers, duties, and liabilities.**

Action of officers executing attachment by stopping operation of plaintiff's mill, instead of procuring a lien of record, under V. S. 1101, 1103, *held* to subject them to exemplary damages.—Friedly v. Giddings (C. C.) 438.

A verdict for \$996 against officers for wrongful execution of attachment, by stopping operation of plaintiff's mill, *held* not excessive.—Friedly v. Giddings (C. C.) 438.

SHIPPING.

See "Admiralty"; "Collision"; "Maritime Liens"; "Salvage"; "Seamen"; "Towage."

§ 1. Charters.

A charter of a steamship for a term construed and *held* to constitute a demise of the vessel, under which the owner could not be held liable to the charterer for the wrongful acts of the officers.—The Del Norte (C. C. A.) 118; Townsley v. Crescent City Transp. Co., Id.

A charterer to whom a steam yacht was demised *held* released by the terms of the charter from liability to the owner for the loss of the vessel through the negligence of the master.—McCormick v. Shippy (D. C.) 226.

A stipulation in a charter demising a vessel, by which the risk of loss or damage to the vessel through the negligence of the master, which the law would otherwise cast upon the

charterer, is assumed by the owner, is not invalid as against public policy.—*McCormick v. Shippy* (D. C.) 226.

§ 2. Carriage of goods.

In the absence of fraud or mistake, parol evidence is not admissible to change the contract made by bills of lading showing the prepayment of freight, which binds the carrier to repay such freight if not earned.—*De Sola v. Pomares* (D. C.) 373; *Amsinck v. Same*, *Id.*

The settled rule of commercial law, that freight prepaid is to be refunded if not earned, cannot be overcome by proof of a custom that it shall not be so refunded if the vessel is lost.—*De Sola v. Pomares* (D. C.) 373; *Amsinck v. Same*, *Id.*

Stipulations in bills of lading that the carrier shall not be liable for any damage to goods which is capable of being covered by insurance will not relieve the vessel from liability for loss due to the carrier's negligence.—*The Seaboard* (D. C.) 375.

Loss of cargo resulting from the overloading of a lighter, due to the negligence of officers of the ship, is within section 1 of the Harter act [U. S. Comp. St. 1901, p. 2946], and not within section 3, and cannot be relieved against by a stipulation in the bills of lading.—*The Seaboard* (D. C.) 375.

The fact that a steamer was being operated under a charter, even if known to shippers, does not relieve her from a lien arising from default in her obligation to the cargo.—*The Seaboard* (D. C.) 375.

A purchaser of a vessel cannot invoke the defense of laches to defeat a suit by an insurer to enforce a lien for the negligent loss of cargo occurring before the purchase, where the suit was commenced within a year after the loss, and it does not appear that he bought without knowledge of the lien.—*The Seaboard* (D. C.) 375.

SMUGGLING.

See "Customs Duties," § 5.

SPECIFIC PERFORMANCE.

Right to enforce specific performance of contract after securing judgment for damages for breach, see "Election of Remedies."

§ 1. Nature and grounds of remedy in general.

Specific performance rests in judicial discretion, and will be granted or refused as will best subserve the ends of justice, in view of the facts of the particular case.—*Washington Irr. Co. v. Krutz* (C. C. A.) 279.

§ 2. Contracts enforceable.

A contract which is champertous under the rules of the common law, even if not voidable under the statute of the state, is so far contrary to public policy that a court of equity will not decree its specific performance.—*Casserleigh v. Wood* (C. C. A.) 308.

STARE DECISIS.

See "Courts," § 1.

STATES.

Jurisdiction of suits against, see "Courts," § 4. Public lands, see "Public Lands," § 3.

§ 1. Political status and relations.

The sudden change in the channel of the Mississippi river, between the states of Tennessee and Arkansas, by a permanent cut-off made by the river during a flood, did not change the boundary between the states, which remained in the middle of the abandoned channel.—*Stockley v. Cissna* (C. C. A.) 812.

An officer of the United States army, acting in the discharge of his duty, in obedience to orders of the secretary of war, who in turn is executing an act of congress, is not subject to arrest on a warrant or order of a state court.—*In re Turner* (D. C.) 231.

STATUTES.

Adoption by United States courts of state laws as rules of decision, see "Courts," § 7.

Provisions relating to particular subjects.

See "Bankruptcy"; "Copyrights"; "Customs Duties"; "Damages," § 1; "Discovery," § 2; "Elections," § 1; "Fraud," § 2; "Limitation of Actions"; "Mechanics' Liens"; "Mines and Minerals," § 1; "Mortgages," § 1; "Post Office"; "War."

Revenue laws, see "Internal Revenue." Revolt by seamen, see "Seamen."

§ 1. Construction and operation.

The title is no part of an act, and cannot enlarge or confer powers, or control the words of the act, unless doubtful or ambiguous.—*United States v. McCrory* (C. C. A.) 861.

Where a statute imposing a tax is susceptible of two constructions, and the legislative intent is in doubt, the doubt should, as a rule, be resolved in favor of the taxpayer.—*McNally v. Field* (C. C.) 445.

STATUTES CONSTRUED.

UNITED STATES.

CONSTITUTION.

Amend. art. 14..... 381

STATUTES AT LARGE.

1867, March 2, ch. 176, 14 Stat. 517..... 510
 1872, June 7, ch. 322, § 51, par. 7, 17 Stat. 273 [U. S. Comp. St. 1901, pp. 3113, 3115]..... 620
 1874, June 22, ch. 391, § 22, 18 Stat. 190 [U. S. Comp. St. 1901, p. 1986]..... 152
 1877, March 3, ch. 114, 19 Stat. 393 [U. S. Comp. St. 1901, p. 2137]..... 411
 1878, June 3, ch. 150, 20 Stat. 88 [U. S. Comp. St. 1901, p. 1528]..... 70, 566
 1883, March 3, ch. 121, § 1, Schedule H, pars. 310, 311, 22 Stat. 504, 505..... 383

1884, April 18, ch. 26, 23 Stat. 11 [U. S. Comp. St. 1901, p. 3679]..... 482
 1884, May 17, ch. 53, § 8, 23 Stat. 24..... 83
 1885, March 3, ch. 319, 23 Stat. 340..... 114
 1887, March 3, ch. 359, 24 Stat. 505 [U. S. Comp. St. 1901, p. 752]. Amended by Act 1898, June 27, ch. 503, 30 Stat. 494 [U. S. Comp. St. 1901, p. 753]..... 861
 1887-88, Aug. 13, ch. 866, §§ 1, 2, 25 Stat. 433 [U. S. Comp. St. 1901, p. 508]..... 210
 1888, May 24, ch. 308, 25 Stat. 157 [U. S. Comp. St. 1901, p. 2037]..... 862
 1888, Aug. 13, ch. 866, § 2, 25 Stat. 433 [U. S. Comp. St. 1901, p. 509]..... 982
 1888, Oct. 8, ch. 1194, 25 Stat. 560 [U. S. Comp. St. 1901, p. 2141]..... 411
 1890, June 10, ch. 407, § 19, 26 Stat. 139 [U. S. Comp. St. 1901, p. 1924]..... 481
 1890, June 10, ch. 407, § 20, 26 Stat. 140 [U. S. Comp. St. 1901, p. 1950]..... 480
 1890, July 2, ch. 647, 26 Stat. 209 [U. S. Comp. St. 1901, p. 3200]..... 922
 1890, Oct. 1, ch. 1244, § 1, Schedule A, pars. 74, 76, 26 Stat. 570..... 472
 1890, Oct. 1, ch. 1244, § 1, Schedule B, par. 108, 26 Stat. 572..... 477
 1890, Oct. 1, ch. 1244, § 1, Schedule N, par. 454, 26 Stat. 601..... 476
 1891, March 3, ch. 565, § 3, 26 Stat. 1107 [U. S. Comp. St. 1901, p. 3407]..... 451
 1892, July 20, ch. 209, 27 Stat. 252 [U. S. Comp. St. 1901, p. 706]..... 491
 1893, Feb. 13, ch. 105, §§ 1, 3, 27 Stat. 445 [U. S. Comp. St. 1901, p. 2946]..... 375
 1894, Aug. 13, ch. 282, 28 Stat. 279 [U. S. Comp. St. 1901, p. 2315]..... 236
 1894, Aug. 15, ch. 290, 28 Stat. 305..... 114
 1894, Aug. 27, ch. 349, 28 Stat. 509..... 384
 1894, Aug. 27, ch. 349, § 1, Schedule H, par. 248, 28 Stat. 526..... 495
 1894, Aug. 27, ch. 349, § 1, Schedule N, par. 338, 28 Stat. 534..... 476
 1894, Aug. 27, ch. 349, § 1, Schedule N, par. 351, 28 Stat. 535..... 477
 1897, July 24, ch. 11, 30 Stat. 151 [U. S. Comp. St. 1901, p. 1626]..... 384
 1897, July 24, ch. 11, § 1, Schedule A, par. 20, 30 Stat. 152 [U. S. Comp. St. 1901, p. 1628]..... 483
 1897, July 24, ch. 11, § 1, Schedule A, par. 58, 30 Stat. 154 [U. S. Comp. St. 1901, p. 1630]..... 470
 1897, July 24, ch. 11, § 1, Schedule A, pars. 66, 67, 30 Stat. 154 [U. S. Comp. St. 1901, pp. 1630, 1631]..... 473
 1897, July 24, ch. 11, § 1, Schedule B, pars. 87, 97, 30 Stat. 155, 156 [U. S. Comp. St. 1901, pp. 1632, 1633]..... 479
 1897, July 24, ch. 11, § 1, Schedule C, par. 121, 30 Stat. 159 [U. S. Comp. St. p. 1636]..... 470
 1897, July 24, ch. 11, § 1, Schedule G, par. 254, 30 Stat. 171 [U. S. Comp. St. 1901, p. 1650]..... 478
 1897, July 24, ch. 11, § 1, Schedule G, par. 285, 30 Stat. 173 [U. S. Comp. St. 1901, p. 1653]..... 483
 1897, July 24, ch. 11, § 2, Free List, par. 633, 30 Stat. 200 [U. S. Comp. St. 1901, p. 1686]..... 584

1897, July 24, ch. 11, § 2, Free List, par. 652, 30 Stat. 201 [U. S. Comp. St. 1901, p. 1687]..... 483
 1897, July 24, ch. 11, § 2, Free List, par. 656, 30 Stat. 201 [U. S. Comp. St. 1901, p. 1687]..... 487
 1897, July 24, ch. 11, § 6, 30 Stat. 205 [U. S. Comp. St. 1901, p. 1693]..... 483
 1897, July 24, ch. 11, § 7, 30 Stat. 205 [U. S. Comp. St. 1901, p. 1693]..... 479
 1898, June 13, ch. 448, 30 Stat. 448 [U. S. Comp. St. 1901, p. 2284]. Amended by Act 1901, March 2, ch. 806, 31 Stat. 945 [U. S. Comp. St. 1901, p. 2304]..... 445
 1898, June 13, ch. 448, § 8, 30 Stat. 452 [U. S. Comp. St. 1901, p. 2293]..... 482
 1898, June 27, ch. 503, 30 Stat. 494 [U. S. Comp. St. 1901, p. 753]..... 861
 1898, July 1, ch. 541, §§ 1, 2, 30 Stat. 544, 545 [U. S. Comp. St. 1901, pp. 3419, 3421]..... 246
 1898, July 1, ch. 541, § 3, 30 Stat. 546, 547 [U. S. Comp. St. 1901, p. 3422]..... 989, 991
 1898, July 1, ch. 541, § 7, 30 Stat. 548 [U. S. Comp. St. 1901, p. 3424]..... 406
 1898, July 1, ch. 541, § 8, 30 Stat. 549 [U. S. Comp. St. 1901, p. 3425]..... 976
 1898, July 1, ch. 541, § 9, 30 Stat. 549 [U. S. Comp. St. 1901, p. 3425]..... 406
 1898, July 1, ch. 541, § 14b, 30 Stat. 550 [U. S. Comp. St. 1901, p. 3427]..... 346
 1898, July 1, ch. 541, § 44, 30 Stat. 557 [U. S. Comp. St. 1901, p. 3438]..... 246
 1898, July 1, ch. 541, § 67e, 30 Stat. 565 [U. S. Comp. St. 1901, p. 3449]..... 107
 1900, Feb. 26, ch. 25, 31 Stat. 33 [U. S. Comp. St. 1901, p. 758]..... 861
 1901, March 2, ch. 806, 31 Stat. 945 [U. S. Comp. St. 1901, p. 2304]..... 445, 994

REVISED STATUTES.

§§ 109, 123 [U. S. Comp. St. 1901, pp. 60, 63]..... 465
 § 643 [U. S. Comp. St. 1901, p. 521]..... 545, 562
 § 649 [U. S. Comp. St. 1901, p. 525]..... 545, 562
 § 724 [U. S. Comp. St. 1901, p. 583]..... 474
 § 914 [U. S. Comp. St. 1901, p. 684]..... 438
 § 916 [U. S. Comp. St. 1901, p. 684]..... 438, 764
 §§ 995, 996 [U. S. Comp. St. 1901, p. 711]..... 1002
 §§ 1000, 1012 [U. S. Comp. St. 1901, pp. 712, 716]..... 148
 § 2324 [U. S. Comp. St. 1901, p. 1426]..... 48
 §§ 2325, 2326 [U. S. Comp. St. 1901, pp. 1429, 1430]..... 164
 § 3257 [U. S. Comp. St. 1901, p. 2137]..... 411
 § 3464 [U. S. Comp. St. 1901, p. 2234]..... 334
 § 4596 [U. S. Comp. St. 1901, pp. 3113, 3115]..... 620
 §§ 4615, 4624, 4625, 4635 [U. S. Comp. St. 1901, pp. 3127, 3130, 3134]..... 386
 § 4952 [U. S. Comp. St. 1901, p. 3406]..... 993
 § 4953 [U. S. Comp. St. 1901, p. 3407]..... 217
 § 4956 [U. S. Comp. St. 1901, pp. 3407]..... 218
 § 4956 [U. S. Comp. St. 1901, p. 3407]. Amended by Act 1891, March 3, ch. 565, § 3, 26 Stat. 1107..... 451
 § 4957 [U. S. Comp. St. 1901, p. 3409]..... 218
 § 4964 [U. S. Comp. St. 1901, p. 3413]..... 217
 § 4968 [U. S. Comp. St. 1901, p. 3416]..... 451
 § 5219 [U. S. Comp. St. 1901, p. 3502]..... 57

§ 5359 [U. S. Comp. St. 1901, p. 3639]... 620
 § 5399 [U. S. Comp. St. 1901, p. 3656]... 416
 § 5448 [U. S. Comp. St. 1901, p. 3679]... 482
 § 5480 [U. S. Comp. St. 1901, p. 3696]... 89

COMPILED STATUTES 1901.

Pages 60, 63 465
 Page 508 210
 Page 509 982
 Page 521 626
 Page 525 545, 562
 Page 583 474
 Page 684 438, 764
 Page 706 491
 Page 711 1002
 Pages 712, 716 148
 Pages 752, 753, 758 861
 Page 1426 48
 Pages 1429, 1430 164
 Page 1528 70, 563
 Page 1626 384
 Page 1628 483
 Page 1630 470, 473
 Page 1631 473
 Pages 1632, 1633 479
 Page 1636 470
 Page 1650 478
 Page 1653 483
 Page 1680 584
 Page 1687 478, 483
 Page 1693 479, 483
 Page 1924 481, 495
 Page 1950 480
 Page 1986 152
 Pages 2112, 2137, 2141 411
 Page 2284 334, 445
 Page 2293 482
 Page 2304 445, 994
 Page 2315 236
 Page 2637 862
 Page 2946 375
 Pages 3113, 3115 620
 Pages 3127, 3130 386
 Pages 3200 922
 Page 3406 993
 Page 3407 217, 218, 451
 Page 3409 218
 Page 3413 217
 Page 3416 451
 Pages 3419, 3421 246
 Page 3422 989, 991
 Page 3424 406
 Page 3425 406, 976
 Page 3427 346
 Page 3438 246
 Page 3449 107
 Page 3502 57
 Page 3639 620
 Page 3656 416
 Page 3679 482
 Page 3696 89

ARKANSAS.

SANDELS & HILL'S DIGEST.

§ 4137 617

LAWS.

1895, April 20, p. 217, ch. 146, §§ 3, 10... 1

CALIFORNIA.
 POLITICAL CODE.

§ 1662 381
 § 3609 57

LAWS.

1887, March 7, p. 29, ch. 34..... 535

COLORADO.

MILLS' ANNOTATED CODE.

§ 281 150

IOWA.

CONSTITUTION.

Art. 11, § 3..... 315

LOUISIANA.

REVISED CIVIL CODE 1870.

Art. 2505 779

MASSACHUSETTS.

LAWS.

1894, June 25, p. 718, ch. 522, § 73..... 630

MICHIGAN.

COMPILED LAWS 1897.

§ 10,421 139

MISSISSIPPI.

Code 1892.

§§ 4425-4428 865

MISSOURI.

REVISED STATUTES 1899.

§ 1264 209

NEVADA.

CUTTING'S COMPILED ANNOTATED
 LAWS.

§§ 3983, 3984..... 400

NEW JERSEY.

GENERAL STATUTES.

Volume 2.

Page 2106, § 22..... 841

LAWS.

1896, April 21, pp. 284, 293, ch. 185, §§ 21,
 48, 49 441

OHIO.

REVISED STATUTES 1892.

§§ 6038-6040 976

LAWS.

1890, March 26, p. 113. Amended by
 Laws 1892, March 7, p. 66..... 36
 1892, March 7, p. 66..... 36

OREGON.

LAWS.

1898, Oct. 14, p. 16..... 48

PENNSYLVANIA.

LAWS.

1854, Feb. 2, p. 37, No. 16, § 28..... 580
 1859, April 14, p. 643, No. 639..... 580

TENNESSEE.

SHANNON'S CODE.

§ 2175 652
 §§ 4025-4029 270
 §§ 5000, 5001..... 813

LAWS.

1847, ch. 20..... 814
 1893, March 17, p. 18, ch. 12..... 652

VERMONT.

STATUTES.

§§ 1101, 1103, 1751..... 438

STIPULATIONS.

A stipulation by the defendant in an action at law to waive a jury and go to trial before the court is not a waiver of his right to insist that plaintiff has no right of action at law.—*Goodyear Shoe Machinery Co. v. Dancel* (C. C. A.) 692.

STOCK.

Corporate stock, see "Corporations," § 1.
 Of building and loan association, see "Building and Loan Associations."

STOCKHOLDERS.

See "Banks and Banking," § 1.
 Of corporations, see "Corporations," § 2.

SUBROGATION.

A mortgagee, who paid off a prior mortgage, held not entitled to be subrogated to the lien of such mortgage, as against an innocent purchaser of an intervening mortgage in reliance on the record, which showed it to be a first lien.—*Coonrod v. Kelly* (C. C. A.) 841.

SUPPLIES.

Maritime liens for supplies, see "Maritime Liens," § 1.

SUSPENSION.

Of benefit insurance, see "Insurance," § 7.

TARIFF.

See "Customs Duties."

TAXATION.

See "Counties," § 1; "Customs Duties"; "Internal Revenue."

Contribution between co-tenants for payment of taxes, see "Tenancy in Common," § 1.

§ 1. Liability of persons and property.

Pol. Code Cal. § 3609, providing for the taxation of national bank shares, construed and held valid.—*Nevada Nat. Bank v. Dodge* (C. C. A.) 57.

A statute providing for the taxation of national bank shares is not invalid because it provides a different system of taxation for such shares from that applied to local banking corporations.—*Nevada Nat. Bank v. Dodge* (C. C. A.) 57.

§ 2. Levy and assessment.

A notice required by statute to be given to a national bank of the assessment of the shares of its respective stockholders is sufficient notice to the stockholders, in connection with the general laws providing for the assessment and fixing the time and place where complaints can be heard and considered.—*Nevada Nat. Bank v. Dodge* (C. C. A.) 57.

TENANCY IN COMMON.

§ 1. Mutual rights, duties, and liabilities of co-tenants.

The grantor of an undivided portion of land to a trustee, with covenants of quiet enjoyment and of warranty, held entitled to contribution for expense incurred in defending a suit involving title to the whole.—*McClintock v. Fontaine* (C. C.) 448.

One who, as trustee owning an individual half of a certain land, pays taxes on the whole, is entitled as a tenant in common to contribution from the other owners, and is therefore entitled to a lien on the land for the amount advanced.—*McClintock v. Fontaine* (C. C.) 448.

TERMS.

Of leases, see "Landlord and Tenant," § 2.

TIMBER.

On public lands, see "Public Lands," § 1.

TITLE.

Color of title, see "Adverse Possession."
 Of copyrighted works, see "Copyrights," § 1.
 Of statute, see "Statutes," § 1.
 To sustain ejectment, see "Ejectment," § 1.

TORTS.

By particular classes of parties.
 See "Municipal Corporations," § 1.

Particular torts.

See "Fraud"; "Libel and Slander"; "Negligence"; "Trespass."
 Causing death, see "Death," § 1.
 Maritime torts, see "Collision."

TOWAGE.

Collisions with tugs and vessels in tow, see "Collision," § 5.

A tug *held* liable for the loss of a scow in tow, which went adrift in the night, where she gave so little attention to the scow that the loss was not discovered for four hours.—*The O. L. Hallenbeck* (D. C.) 468; *Olsen v. Cabill*, Id.

TOWNS.

See "Counties."

TRADE-MARKS AND TRADE-NAMES.

§ 1. Marks and names subjects of ownership.

The word "Carroms" *held* to constitute a valid trade-mark as applied to a game board.—*Ludington Novelty Co. v. Leonard* (C. C.) 937; *Same v. Fischer*, Id.

§ 2. Infringement and unfair competition.

A bill *held* not to state facts making a case for relief on the ground of unfair competition.—*Globe-Wernicke Co. v. Fred Macey Co.* (C. C. A.) 696.

The labels and packages of complainant and defendant compared, and *held* so dissimilar in appearance, regarded as a whole, that defendant could not be charged with unfair competition, in the absence of evidence that purchasers were actually deceived.—*Postum Cereal Co. v. American Health Food Co.* (C. C. A.) 848.

The trade-mark "Grape Nuts," adopted as the name of a cereal food preparation, is not infringed by the name "Grain Hearts," used to designate a similar product.—*Postum Cereal Co. v. American Health Food Co.* (C. C. A.) 848.

The publisher of a periodical, under the name of "Comfort" *held* not entitled to an injunction against the use of the name "Home Comfort," as the title of another publication which was dissimilar in size, appearance, and the character of its contents, and was not in fact a competitor, in the absence of proof of actual injury to complainant.—*Gannett v. Ruppert* (C. C.) 221.

The publisher of a periodical will be protected in the exclusive use of its name to which he has acquired a prior right, when its use by another is with intent to deceive, or is calculated to deceive and result in injury to complainant.—*Gannett v. Ruppert* (C. C.) 221.

TRESPASS.

On public lands, see "Public Lands," § 1.

§ 1. Acts constituting trespass and liability therefor.

The test which determined whether one was a willful or an innocent trespasser is the honest belief and actual intent at the time he committed the trespass.—*United States v. Gentry* (C. C. A.) 70.

TRESPASS TO TRY TITLE.

See "Ejectment."

TRIAL.

See "New Trial"; "Reference"; "Witnesses."

Proceedings incident to trials.

Entry of judgment after trial of issues, see "Judgment," § 1.

Trial of particular civil actions or proceedings.

See "Negligence," § 2.

For damages for taking or injuring property for public use, see "Eminent Domain," § 2. For personal injuries, see "Master and Servant," § 1.

§ 1. Arguments and conduct of counsel.

Defendant *held* not entitled to a new trial for misconduct of the assistant district attorney in argument.—*United States v. Alexander* (C. C.) 1015.

§ 2. Instructions to jury.

In the federal courts, a trial judge is not required to specifically and directly answer every point which may be submitted by counsel. If the instructions given, as a whole, fully, correctly, and clearly present the law, nothing further can be required.—*Salem Iron Co. v. Commonwealth Iron Co.* (C. C. A.) 593.

The practice of presenting instructions to the court after the charge to the jury has been given cannot be sanctioned, and assignments of error based on the refusal to give such instructions will not be considered by the appellate court.—*City of Chicago v. Le Moynes* (C. C. A.) 662.

§ 3. Trial by court.

A special finding made by a circuit court, where a jury is waived by stipulation, pursuant to Rev. St. § 649 [U. S. Comp. St. 1901, p. 525], should state the ultimate facts, on which the law must determine the rights of the parties, and should not contain a statement of the evidence.—*American Nat. Bank v. Watkins* (C. C. A.) 545.

A special finding that plaintiff was not a bona fide purchaser of a note for value, but took the same subject to any defense affecting the consideration, is one of fact, and not reviewable on appeal as a conclusion of law.—*American Nat. Bank v. Watkins* (C. C. A.) 545.

A special finding of facts by a circuit court in an action at law, where a jury is waived, must state the ultimate facts, on which the law must determine the rights of the parties.—*Powerz v. United States* (C. C. A.) 562.

TRUSTS.

Combinations to monopolize trade, see "Monopolies," § 1.

Trust deeds, see "Chattel Mortgages"; "Mortgages."

§ 1. Establishment and enforcement of trust.

A bill *held* to state a cause of action for relief in equity as against a demurrer.—*Ammon-Stivers Min. Co. v. Great Northern Mining & Development Co.* (C. C.) 377.

Allegations of a bill *held* insufficient to establish a trust in land in favor of the "Jews of Newport," or to show any interest therein in complainants.—*David v. Levy* (C. C.) 799.

TUGS.

See "Towage."

ULTRA VIRES.

See "Corporations," § 4.

UNFAIR COMPETITION.

See "Trade-Marks and Trade-Names," § 2.
In copying market quotations, see "Literary Property."

UNITED STATES.

See "Customs Duties"; "Post Office."
Courts, see "Courts," §§ 2-9; "Removal of Causes."
False personation of United States officer, see "False Personation."
Indians, see "Indians."
Public lands, see "Public Lands," § 2.
Resisting United States officer, see "Obstructing Justice."

USURY.

Determination as to whether interest is lawful or usurious, see "Interest," § 1.

VALUE.

Limits of jurisdiction, see "Courts," § 5; "Removal of Causes," § 5.

VARIANCE.

Between pleading and proof in civil actions, see "Equity," § 2.
Between pleading and proof in criminal prosecutions, see "Indictment and Information," § 2.

VENDOR AND PURCHASER.

Sales of realty, see "Sales."
Specific performance of contract, see "Specific Performance."

§ 1. Remedies of purchaser.

The mere fact that a commissioner of the general land office had the word "Canceled" written across the record of a patent, 55 years after its issuance, does not constitute an eviction of the person holding title and possession under such patent, so as to entitle him to re-

cover from his vendor for a failure of title.—*Ellis v. John Crossley & Sons* (C. C.) 779.

A purchaser of land cannot recover the purchase money paid in an action at law against his vendor, on the theory of an eviction, merely because he subsequently secured the issuance of a patent to the land from the United States which inured to his benefit.—*Ellis v. John Crossley & Sons* (C. C.) 779.

A purchaser of lands in Louisiana conveyed with a restricted warranty *held* to have purchased at his own peril and risk, within the meaning of the state statute, and therefore not to be entitled to recover from his vendor on failure of his title.—*Ellis v. John Crossley & Sons* (C. C.) 779.

VENUE.

District in which suit must be brought, see "Courts," § 2.

VERDICT.

Setting aside, see "New Trial," § 1.

VICE PRINCIPALS.

See "Master and Servant," § 1.

VOTERS.

See "Elections."

WAIVER.

Stipulation to waive jury as waiver of right to maintain action at law, see "Stipulations."

Of rights or remedies.

Proof of loss under insurance policy, see "Insurance," § 5.

To remove cause to federal court, see "Removal of Causes," § 1.

WAR.

A captured vessel *held* not appropriated for the use of the government, within Rev. St. §§ 4615, 4624, 4625 [U. S. Comp. St. 1901, pp. 3127, 3130], so as to entitle the captors to prize money, where they destroy it to prevent recapture.—*The Santo Domingo* (D. C.) 386.

Order 492 of the navy department *held* not to authorize destruction of a prize with the view of converting it to public use.—*The Santo Domingo* (D. C.) 386.

Captors of a war vessel, destroying it to prevent recapture, *held* not entitled to prize money, but to a bounty, under Rev. St. § 4635.—*The Santo Domingo* (D. C.) 386.

WARNINGS.

As to use of machinery, see "Master and Servant," § 1.

WATERS AND WATER COURSES.

See "Navigable Waters."

WIDOWS.

Of bankrupts, see "Bankruptcy," § 7.

WITNESSES.

See "Evidence."

Experts, see "Evidence," § 6.

Opinions, see "Evidence," § 6.

§ 1. Examination.

The Pennsylvania act permitting a party to be called and examined "as on cross-examination" has no application in a suit in equity in a federal court; and a party so called and examined therein becomes a witness for the party calling him, and his testimony is to be given weight accordingly.—*Calivada Colonization Co. v. Hays* (C. C.) 202.

§ 2. Credibility, impeachment, contradiction, and corroboration.

A witness may be as thoroughly discredited by the inherent improbabilities of his testimony as by the testimony of other witnesses.—*In re Leslie* (D. C.) 406.

WORK AND LABOR.

Liens for work and materials, see "Mechanics' Liens."

WRECKS.

In navigable streams, see "Navigable Waters," § 1.

WRITS.*Particular writs.*

See "Habeas Corpus"; "Injunction."

Writ of error, see "Appeal and Error."

