

IRC : 18-2000

**DESIGN CRITERIA
FOR
PRESTRESSED CONCRETE ROAD
BRIDGES
(POST-TENSIONED CONCRETE)**

(Third Revision)



**THE INDIAN ROADS CONGRESS
2000**

IRC : 18-2000

**DESIGN CRITERIA
FOR
PRESTRESSED CONCRETE ROAD
BRIDGES
(POST-TENSIONED CONCRETE)**

(Third Revision)

Published by
THE INDIAN ROADS CONGRESS
Jamnagar House, Shahjahan Road,
New Delhi-110011
2000

*Price Rs. 120/-
(Plus packing & postage)*

IRC : 18-2000

First published : December, 1965
Reprinted : October, 1969
Reprinted : February, 1974
First Revision : January, 1977
Reprinted : July, 1983 (with Notations and units as per IRC : 71)
Second Revision : November, 1985
Reprinted : September, 1990
Reprinted : December, 1997 (with latest amendments)
Third Revision : October, 2000
Reprinted : September, 2002
(with latest amendments)

(Rights of Publication and of Translation are reserved)

Printed at Dee Kay Printers, New Delhi-110015
1000 Copies - September, 2002

IRC : 18-2000

CONTENTS

	<i>Page No.</i>
Composition of Bridge Specifications & Standards Committee	(i) to (ii)
Notations	(iii) to (v)
Clause No.	
1. Introduction	1
2. Scope	2
3. Materials	3
4. Concrete	7
5. Loads and Forces	7
6. Stage Prestressing	8
7. Permissible Stresses in Concrete	8
8. Permissible Stresses in Prestressing Steel	11
9. Section Properties	11
10. Moduli of Elasticity	14
11. Losses in Prestress	15
12. Ultimate Strength	20
13. Calculation of Ultimate Strength	20
14. Shear and Torsion	21
15. Minimum Reinforcement	30
16. Cover and Spacing of Prestressing Steel	32
17. End Blocks	34
18. Thickening of Webs of Girders	37
19. Anchorage of Cables and Stressing	37
20. Splay of Cables in Plan and Minimum Radius of Cables in Elevation	37
21. Slender Beams	38
22. Emergency Cables/Strands	38
23. Storage and Handling of Prestressing Materials	38
24. Prestressing Operation	38
25. Grouting of Cables	38
Appendices	
1A. Tests on Sheathing Ducts	39
1B. Tests on Corrugated HDPE Sheathing Ducts	45
2. Specification for Sheathing Duct Joints	48
3. Recommended Practice for Storages and Handling of Prestressing Material	50
4. Recommended Practice for Prestressing Operations	51
5. Recommended Practice for Grouting of Post-Tensioned Cables in Prestressed Concrete Bridges	52

MEMBERS OF THE BRIDGE SPECIFICATIONS AND STANDARDS COMMITTEE

(As on 7.12.99)

- | | | |
|-----|---|--|
| 1. | Prafulla Kumar*
(Convenor) | DG(RD) & Addl. Secretary, Ministry of Surface Transport
(Roads Wing), Transport Bhawan, New Delhi-110001 |
| 2. | The Chief Engineer(B)
S&R (Member-Secretary) | (V. Velayutham), Ministry of Surface Transport
(Roads Wing), Transport Bhawan, New Delhi-110001 |
| 3. | S.S. Chakraborty | Managing Director, Consulting Engg. Services (I) Ltd., 57,
Nehru Place, New Delhi-110019 |
| 4. | Dr. M.G. Tamhankar | Emeritus Scientist, Structural Engg. Res. Centre, 399, Pocket
E, Mayur Vihar Phase II, Delhi-110091 |
| 5. | Ninan Koshi | DG(RD) & Addl. Secretary (Retd.), 56, Nalanda Apartments,
Vikasपुरी, New Delhi |
| 6. | A.G. Borkar | Technical Adviser to Metropolitan Commr., A-I, Susnehi Plot
No. 22, Arun Kumar Vaidya Nagar, Bandra Reclamation,
Mumbai-400050 |
| 7. | N.K. Sinha | Chief Engineer (PIC), Ministry of Surface Transport (Roads
Wing), Transport Bhawan, New Delhi-110001 |
| 8. | M.V.B. Rao | Head, Bridge Division, Central Road Research Institute, P.O.
CRRI, New Delhi-110020 |
| 9. | C.R. Alimchandani | Chairman & Managing Director (STUP Consultants Ltd.,
1004-5, Raheja Chambers, 213, Nariman Point, Mumbai-
400021 |
| 10. | Dr. S.K. Thakkar | Professor, Department of Earthquake Engg., University of
Roorkee, Roorkee-247667 |
| 11. | M.K. Bhagwagar | Consulting Engineer, Engg. Consultants (P) Ltd., F-14/15,
Connaught Place, New Delhi-110001 |
| 12. | P.D. Wani | Member, Maharashtra Public Service Commission, Bank of
India Building, Mumbai-400025 |
| 13. | S.A. Reddi | Dy. Managing Director, Gammon India Ltd., Gammon House,
Prabhadevi, Mumbai-400025 |
| 14. | Vijay Kumar | Managing Director, UP State Bridge Corporation Ltd., Setu
Bhavan, 16, Madan Mohan Malviya Marg, Lucknow-226001 |
| 15. | C.V. Kand | Consultant, E-2/136, Mahavir Nagar, Bhopal-462016 |
| 16. | M.K. Mukherjee | 40/182, C.R. Park, New Delhi-110019 |
| 17. | Mahesh Tandon | Managing Director, Tandon Consultants (P) Ltd., 17, Link
Road, Jangpura, Extn., New Delhi |
| 18. | Dr. T.N. Subba Rao | Chairman, Construma Consultancy (P) Ltd., 2nd Floor, Pinky
Plaza, Mumbai-400052 |
| 19. | A.K. Harit | Executive Director (B&S), Research Designs & Standards
Organisation, Lucknow-226001 |
| 20. | A.D. Narain | Director General (Road Development) & Addl. Secy., MOST
(Retd.), B-186, Sector 26, NOIDA |
| 21. | V.R. Jayadas | Chief Engineer, Dy. Director General (B), DGBR, Seema
Sadak Bhavan, Delhi Cantt., Naraina, New Delhi-66 |
| 22. | P.C. Bhasin | 324, Mandakini Enclave, Alkananda, New Delhi-110019 |

*ADG(B) being not in position. The meeting was presided by Shri Prafulla Kumar, Director
*General (Road Development) and Addl. Secretary, Ministry of Surface Transport.

23. P.K. Sarmah Chief Engineer, PWD (Roads) Assam, P.O. Chandmari, Guwahati-781003
24. S.R. Tambe Secretary, Maharashtra PWD (Retd.), 72, Pranit J. Palkar Marg, Opp. Podar Hospital, Worli, Mumbai-400025
25. The Secretary to the Govt. of Gujarat (H.P. Jamdar) R&B Department, Block No. 14, New Sachivalaya, 2nd Floor, Gandhinagar-382010
26. The Chief Engineer (R&B) (D. Sree Rama Murthy), National Highways, Irrum Manzil, Hyderabad-500482
27. The Chief Engineer(NH) (D. Guha), Public Works Department, Writers' Building, Block C, Calcutta-700001
28. The Engineer-in-Chief (R.R. Sheoran), Haryana P.W.D., B&R, Sector-19 B, Chandigarh-160019
29. The Director General (Works) Central Public Works Department, Nirman Bhawan, New Delhi
30. The Chief Engineer Ministry of Surface Transport (Roads Wing), New Delhi
31. The Chief Engineer (R) S&R (C.C. Bhattacharya), Ministry of Surface Transport (Roads Wing), Transport Bhawan, New Delhi
32. The Director Highways Research Station, 76 Sarthat Patel Road, Chennai-600025.
33. The Director & Head Bureau of Indian Standards, Manak Bhawan, 9, Bahadurshah Zafar Marg, New Delhi-110002
34. The Chief Engineer (NH) M.P. Public Works Department, Bhopal-461004
35. The Chief Engineer (NH) U.P. P.W.D., Lucknow
36. The Chief Engineer (NH) Punjab PWD, B&R Branch, Patiala

Ex-Officio Members

37. President K.B. Rajoria
Indian Roads Congress Engineer-in-Chief, Delhi, PWD, New Delhi
38. Director General Prafulla Kumar,
(Road Development) DG(RD) & Addl. Secretary to the Govt. of India, Ministry of Surface Transport (Roads Wing), Transport Bhawan, New Delhi-110001
39. Secretary, S.C. Sharma,
Indian Roads Congress Chief Engineer, Ministry of Surface Transport (Roads Wing) Transport Bhawan, New Delhi-110001

Corresponding Members

1. N.V. Merani Principal Secretary (Retd.), A-47/1344, Adarsh Nagar, Worli, Mumbai-400083
2. Dr. G.P. Saha Chief Engineer, Hindustan Construction Co. Ltd., Hincon House, Lal Bahadur Shastri Marg, Vikhroli (W), Mumbai-400083
3. Shitala Sharan Advisor Consultant, Consulting Engg. Services (I) Pvt. Ltd., 57, Nehru Place, New Delhi-110019

NOTATIONS

- A_s : Area of High Tensile Steel
- A : Area of longitudinal reinforcement
- A_{sv} : Cross-sectional area of two legs of a link
- A_t : Area of connector steel
- A_o : Area enclosed by the centre line of members forming a box section
- A_1 : Bearing area of the anchorage converted in shape to a square of equivalent area
- A_2 : Maximum area of the square that can be contained within the member without overlapping the corresponding area of the adjacent anchorages, and concentric with the bearing area 'A'.
- b : Width of a rectangular section or rib of a Tee, L or I beam
- b_1 : Side of anchor plate
- B : Width of flange of Tee or L beam
- d : Overall depth of the girder measured from top of deck slab to the soffit of girder
- d_b : Depth of the girder from the maximum compression edge to the centre of gravity of the tendons
- d_s : Diameter of prestressing wire/strand
- d_t : Depth from extreme compression fibre either to the longitudinal bars or the centroid of the tendons, whichever is greater
- E_c : Modulus of Elasticity of concrete at 28 days
- E_s : Modulus of Elasticity of prestressing steel
- E_{cj} : Modulus of Elasticity of Concrete at j days ($j < 28$ days)
- e : Base of Napierian Logarithms
- F_{bst} : Bursting tensile force in end block
- f_{cav} : Average compressive stress in flexural compressive zone
- f_{cf} : Actual concrete cube strength at j days subject to a maximum value of f_{ck} ($j < 28$ days)
- f_{ck} : Characteristic compressive strength of 15 cm cubes at 28 days
- f_{cp} : Compressive stress at centroidal axis due to prestress taken as positive
- f_b : Permissible compressive contact stress in concrete including any prevailing stress as in the case of intermediate anchorages
- f_p : Ultimate tensile strength of prestressing steel
- f_{pt} : Stress due to prestress only at the tensile fibre distance 'y' from the centroid of the concrete section

f_t	: Maximum principal tensile stress in concrete
f_y	: The characteristic strength of the untensioned steel
f_{yc}	: Yield stress of longitudinal steel in compression
f_{yl}	: Yield strength of longitudinal reinforcement or 0.2 per cent proof stress which should be taken as not greater than 415 MPa
f_{yv}	: Yield strength of links/shear reinforcement or 0.2 per cent proof stress which should be taken as not greater than 415 MPa
G	: Dead load
H_{max}	: Larger dimension of the section
H_{min}	: Smaller dimension of the section
h_{wo}	: Wall thickness of members of box section where torsional stress is determined
I	: Second moment of area of the section
k	: Wobble co-efficient per metre length of prestressing steel
l	: Length of specimen
M	: Bending moment at the section
MPa	: Mega Pascals
M_t	: Cracking moment at the concrete section considered
M_{ult}	: Moment of section under ultimate load condition
n	: Number of test strength results
P_k	: Load in tendon
Q	: Design live load including impact
S	: Standard deviation (Sample).
SG	: Superimposed dead load
S_t	: Spacing of connectors
S_v	: Link spacing along the length of a member
T	: Torsional moment due to ultimate loads
t	: Thickness of flange of a Tee beam
V	: Shear force at the section considered under ultimate loads, actual volume of water
V_a	: Premeasured quantity of water
V_b	: Balance quantity of water left
V_c	: Ultimate shear resistance of a concrete section
V_{co}	: Ultimate shear resistance of a concrete section uncracked in flexure
V_p	: Volume of sheathing sample used in water loss study
V_{cr}	: Ultimate shear resistance of a concrete section, cracked in flexure

V_{tc}	: Torsional shear stress in concrete section upto which no torsional reinforcement is required
V_t	: Torsional shear stress at a section
V_{tu}	: Ultimate torsional shear stress at a section
x	: Distance in metre between points of operation of σ_{po} and $\sigma_{po}(x)$
X	: Smaller dimension of links measured between centres of legs
y	: Tensile fibre distance from the centroid of the concrete section
Y_{po}	: $\frac{\text{Side of loaded area of end block}}{2}$
Y_o	: $\frac{\text{Side of end block}}{2}$
Y_l	: Larger dimension of links measured between centres of legs
Δ	: Deviation of individual test strength from the average test strength of 'n' test strength results
μ	: Co-efficient of friction between cable and duct
θ	: Cumulative angle in radian through which the tangent to the cable profile has turned between the points of operation of σ_{po} and $\sigma_{po}(x)$
σ	: Standard deviation (population)
σ_{po}	: Steel stress at the jacking end
$\sigma_{po}(x)$: Steel stress at a point, distant 'x' from the jacking end
ϕ	: Internal nominal diameter of sheathing

1. INTRODUCTION

The Design Criteria for Prestressed Concrete Road Bridges (Post-Tensioned Concrete) was first published in December, 1965. To cater for the technological developments which were taking place in course of time, the Criteria were examined by the Technical Committees of the IRC and revised in 1977 and 1985 in the light of their recommendations.

In the light of further developments in the field of prestressed concrete, the task of reviewing the criteria and carrying out required revisions was entrusted to the Committee for Reinforced, Prestressed and Composite Concrete (B-6) consisting of the following personnel :

Ninan Koshi	..	<i>Convenor</i>
A.N. Dhodapkar	..	<i>Member-Secretary</i>

MEMBERS

N.K. Sinha	Jose Kurien
S.G. Joglekar	P.Y. Manjure
Dr. T.N. Subba Rao	A.S. Prasada Rao
M.K. Mukherjee	R.A. Chaudhary
Dr. M.G. Tamhankar	G.R. Haridas
Shitala Sharan	D.D. Sharma
Mahesh Tandon	Director & Head, Civil Engg.
S.A. Reddi	Bureau of Indian Standard
Ashok K. Basa	(Vinod Kumar)
	T. Viswanathan

EX-OFFICIO MEMBERS

President, IRC (K.B. Rajoria)	DG(RD) (Prafulla Kumar)
	Secretary, IRC (S.C. Sharma)

CORRESPONDING MEMBER

P.S. Tyagi

1. INTRODUCTION

The Design Criteria for Prestressed Concrete Road Bridges (Post-Tensioned Concrete) was first published in December, 1965. To cater for the technological developments which were taking place in course of time, the Criteria were examined by the Technical Committees of the IRC and revised in 1977 and 1985 in the light of their recommendations.

In the light of further developments in the field of prestressed concrete, the task of reviewing the criteria and carrying out required revisions was entrusted to the Committee for Reinforced, Prestressed and Composite Concrete (B-6) consisting of the following personnel :

Ninan Koshi	..	<i>Convenor</i>
A.N. Dhodapkar	..	<i>Member-Secretary</i>

MEMBERS

N.K. Sinha	Jose Kurien
S.G. Joglekar	P.Y. Manjure
Dr. T.N. Subba Rao	A.S. Prasada Rao
M.K. Mukherjee	R.A. Chaudhary
Dr. M.G. Tamhankar	G.R. Haridas
Shitala Sharan	D.D. Sharma
Mahesh Tandon	Director & Head, Civil Engg.
S.A. Reddi	Bureau of Indian Standard
Ashok K. Basa	(Vinod Kumar)

T. Viswanathan

EX-OFFICIO MEMBERS

President, IRC (K.B. Rajoria)	DG(RD) (Prafulla Kumar)
	Secretary, IRC (S.C. Sharma)

CORRESPONDING MEMBER

P.S. Tyagi

The amendments as finalised by this Committee were considered and approved by the Bridge Specifications and Standards Committee in their meeting held at New Delhi on 7th December, 1999 and later approved by the Executive Committee in their meeting held at New Delhi on 14th December, 1999. The draft amendments were discussed and approved by the Council of the Indian Roads Congress at the 157th Council Meeting held at Madurai on 4th January, 2000.

It was also decided that the document would be published as a fully revised Criteria after incorporating all the amendments.

The object of issuing this publication is to establish a common procedure for the design and construction of Prestressed Concrete Road Bridges in India. The publication is meant to serve as a guide to both the design engineers and the construction engineers but compliance with the provisions therein does not relieve them in any way of the responsibility for the stability, soundness and safety of the structures designed and erected by them.

The design and construction of road bridges require an extensive and thorough knowledge of science and technique involved and should be entrusted only to specially qualified engineers with adequate experience of bridge engineering, capable of ensuring careful execution of work.

2. SCOPE

These Criteria cover the design aspects for prestressed concrete (post-tensioned) road bridges (determinate structures only). These are not applicable to the design of members which are subjected to direct compression like piers.

3. MATERIALS

3.1. Cement

Any of the following shall be used with prior approval of the competent authority :

- (a) Ordinary Portland Cement conforming to IS: 269
- (b) High Strength Portland Cement conforming to IS: 8112
- (c) Ordinary Portland Cement conforming to IS:12269 (Grade 53)
- (d) Sulphate Resistant Portland Cement conforming to IS:12330.

3.2. Aggregates

All coarse and fine aggregates shall conform to IS:383 and tests for conformity shall be carried out as per IS:2386 Parts I to VIII.

3.2.1. Coarse aggregate

3.2.1.1. Coarse aggregate shall consist of clean, hard, strong, dense non-porous and durable pieces of crushed stone, crushed gravel, natural gravel or a suitable combination thereof or other approved inert material. It shall not contain pieces of disintegrated stones, soft, flaky elongated particles, salt, alkali, vegetable matter or other deleterious materials in such quantities as to reduce the strength or durability of the concrete, or to attack the embedded steel.

The nominal maximum size of aggregates shall usually be restricted to 10 mm less than the minimum clear distance between individual cables or individual untensioned steel reinforcement or 10 mm less than the minimum cover to untensioned steel reinforcement, whichever is smaller. A nominal size of 20 mm coarse aggregates shall generally be considered satisfactory for prestressed concrete work.

3.2.2. **Fine aggregates** : Fine aggregates shall conform to Clause 302.3.3 of IRC:21.

3.3. Water

Water used for mixing and curing shall be in conformity with Clause 302.4 of IRC:21.

3.4. Admixtures may be used in conformity with Clause 302.2 of IRC:21.

3.5. Steel

3.5.1. The prestressing steel shall be any of the following:

- (a) Plain hard drawn steel wire conforming to IS: 1785 (Part I) and IS: 1785 (Part II)
- (b) Cold drawn indented wire conforming to IS:6003
- (c) High tensile steel bar conforming to IS:2090
- (d) Uncoated stress relieved strand conforming to IS:6006, and
- (e) Uncoated stress relieved low relaxation steel conforming to IS:14268.

Data in respect of modulus of elasticity, relaxation loss at 1000 hrs., minimum ultimate tensile strength, stress-strain curve etc. shall necessarily be obtained from manufacturers. Prestressing steel shall be subjected to acceptance tests prior to actual use on the works (guidance may be taken from BS:4447). The modulus of elasticity value, as per acceptance tests, shall conform to the design value which shall be within a range not more than 5 per cent between the maximum and minimum.

3.5.2. **Untensioned steel** : Reinforcement used as untensioned steel shall be any of the following :

- (a) Mild steel and medium tensile steel bars conforming to IS:432 (Part I)

(b) High strength deformed steel bars conforming to IS:1786 and

(c) Hard drawn steel wire fabric conforming to IS:1566.

The reinforcement bars bent and fixed in position shall be free from rust or scales, chloride contamination and other corrosion products. Where cleaning of corroded portions is required, effective method of cleaning such as sand blasting shall be adopted.

3.5.3. Prestressing accessories like jacks, anchorage, wedges, block plates, etc. being patented items shall be obtained from authorised manufacturers only. The prestressing components and accessories shall be subjected to an acceptance test prior to their actual use on the works (guidance may be taken from BS:4447).

3.6. Sheathing Ducts

The sheathing ducts shall be either in mild steel as per the sub-clause 3.6.1 or in HDPE as per sub-clause 3.6.2. They shall be in as long lengths as practical from handling and transportation considerations without getting damaged. They shall conform to the requirements specified in *Appendix-1A/1B* and a test certificate shall be furnished by the manufacturer. The tests specified in *Appendix-1B* are to be performed as part of additional acceptance tests for prestressing systems employing corrugated HDPE sheathing ducts and are not meant for routine site testing purposes.

3.6.1. MS sheathing ducts

3.6.1.1. Unless otherwise specified, the material shall be Cold Rolled Cold Annealed (CRCA) Mild Steel intended for mechanical treatment and surface refining but not for quench hardening or tempering.

3.6.1.2. The material shall be clean and free from rust and normally of bright metal finish. However, in case of use in aggressive environment galvanised or lead coated mild steel strips shall be adopted.

3.6.1.3. The thickness of metal sheathing shall not be less than 0.3 mm, 0.4 mm and 0.5 mm for sheathing ducts having internal diameter upto 50 mm, 75 mm and 90 mm respectively. For bigger diameter of ducts, thickness of sheathing shall be based on recommendations of prestressing system supplier.

3.6.1.4. The sheathing shall conform to the requirements specified in *Appendix-1A* and a test certificate shall be furnished by the manufacturer.

3.6.1.5. The joints of all sheathing shall be water tight and conform to the provisions contained in *Appendix-2*.

3.6.2. Corrugated HDPE sheathing ducts

3.6.2.1. Unless otherwise specified, the material for the ducts shall be high-density polyethylene with more than 2 per cent carbon black to provide resistance to ultraviolet degradation and shall have the following properties :

Specific Density	:	0.954 g/cm ³ at 23°C
Yield Stress	:	18.0 N/mm ²
Tensile Strength	:	21.0 N/mm ²
Shore Hardness D-3 sec. value	:	60
-15 sec. value	:	58
Notch impact strength at 23°C	:	10 kJ/m ²
-40°C	:	4 kJ/m ²
Coefficient of Thermal Expansion for 20°C - 80°C	:	1.50 x 10 ⁻⁴ kJ/m ²

3.6.2.2. The thickness of the wall shall be 2.3 ± 0.3 mm as manufactured and 1.5 mm after loss in the compression test, for duct size upto 160 mm OD.

3.6.2.3. The ducts shall be corrugated on both sides. The ducts shall transmit full tendon strength from the tendon to the surrounding concrete over a length not greater than 40 duct diameters.

3.6.2.4. These ducts shall be joined by adopting any one or more of the following methods, as convenient to suit the individual requirements of the location, subject to the satisfactory pressure tests, before adoption.

- * Screwed together with male and female threads.
- * Joining with thick walled HDPE shrink couplers with glue. This can also be used for connection with trumpet, etc.
- * Welding with electrofusion couplers.

The joints shall be able to withstand an internal pressure of 0.5 bar for 5 minutes as per test procedure given in *Appendix-1A*.

4. CONCRETE

Concrete shall be in accordance with Clause 302.6 of IRC:21.

5. LOADS AND FORCES

5.1. The loads and forces and load combinations as per IRC:6-1966 and as applicable for the given structure shall be duly accounted for.

5.2. All critical loading stages shall be investigated. The stages stated below may normally be investigated:

- (i) Stage prestressing;
- (ii) Construction stages including temporary loading, transport, handling and erection or any occasional loads that may occur during launching of girders, etc. including impact, if any;

- (iii) The design loads as per load combination of 5.1 above including the following discrete stages:
- (a) Service Dead Load+Prestress with full losses.
 - (b) Service Dead Load+Live Load+Prestress with full losses.
- (iv) For the combination of loads with differential temperature gradient effects, maximum 50 per cent live load shall be considered and any tensile stresses shall be taken care of by providing adequately designed untensioned steel subject to the crack width limitations stipulated in IRC:21. This shall apply notwithstanding the provision contained in Clause 7.2.2. However, in the case of precast segmental construction no tension shall be permitted under this load combination.
- (v) Ultimate load, as per Clause 12.

6. STAGE PRESTRESSING

Stage prestressing is permissible. The number of stages of prestressing and grouting shall be reduced to the minimum, preferably not more than 2. However, concrete shall have attained a strength of not less than 20 MPa before any prestressing is applied.

7. PERMISSIBLE STRESSES IN CONCRETE

7.1. Permissible Temporary Stresses in Concrete

7.1.1 These stresses are calculated after accounting for all appropriate losses, pertaining to the stage of construction, as per Clause 11.

7.1.2. The compressive stress produced due to loading mentioned in Clause 5.2 (ii) shall not exceed $0.5 f_{cj}$ which shall not be more than 20 MPa, where f_{cj} is the concrete strength at that time subject to a maximum value of f_{ck} .

7.1.3. At full transfer the cube strength of concrete shall not be less than $0.8 f_{ck}$. Temporary compressive stress in the extreme fibre of concrete (including stage prestressing) shall not exceed $0.50 f_{cj}$ subject to a maximum of 20 MPa.

7.1.4. The temporary tensile stresses in the extreme fibres of concrete shall not exceed 1/10th of the permissible temporary compressive stress in the concrete.

7.2. Permissible Stress in Concrete during Service

7.2.1. The compressive stress in concrete under service loads shall not exceed $0.33 f_{ck}$.

7.2.2. No tensile stress shall be permitted in the concrete during service.

7.2.3. If pre-cast segmental elements are joined by prestressing, the stresses in the extreme fibres of concrete during service shall always be compressive and the minimum compressive stress in an extreme fibre shall not be less than five per cent of maximum permanent compressive stress that may be developed in the same section. This provision shall not, however, apply to cross prestressed deck slabs.

7.2.4. The structure shall also be checked for 20 per cent higher time dependent losses like creep, shrinkage, relaxation, etc. Under this condition, no tensile stress shall be permitted.

7.3. Permissible Bearing Stress Behind Anchorages

The maximum allowable stress, immediately behind the anchorages in adequately reinforced end blocks may be calculated

by the equation :

$$f_b = 0.48 f_{cj} \sqrt{\frac{A_2}{A_1}} \text{ or } 0.8 f_{cj} \text{ whichever is smaller}$$

Where f_b = the permissible compressive contact stress in concrete including any prevailing stress as in the case of intermediate anchorages

A_1 = the bearing area of the anchorage converted in shape to a square of equivalent area

A_2 = the maximum area of the square that can be contained within the member without overlapping the corresponding area of adjacent anchorages, and concentric with the bearing area A_1 .

Notes : (i) The above value of bearing stress is permissible only if there is a projection of concrete of at least 50 mm or $b/4$, whichever is more all round the anchorage, where b is as shown in Fig. 1.

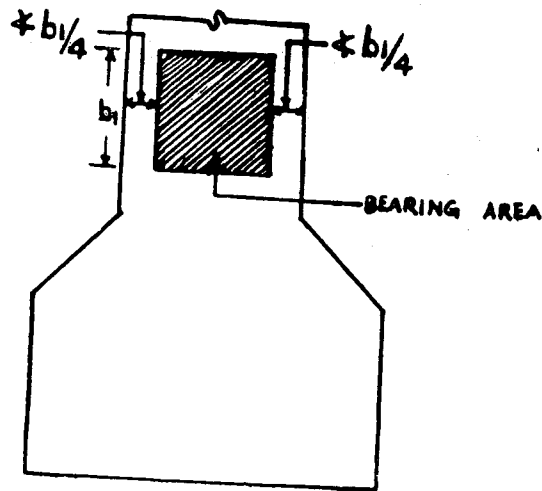

Fig. 1.

- (ii) Where embedded anchorages are provided, the reinforcement details, concrete strength, cover and other dimensions shall conform to the manufacturer's specifications/specialist literature.
- (iii) The pressure operating on the anchorage shall be taken before allowing for losses due to creep and shrinkage of concrete and relaxation of steel, but after allowing for losses due to elastic shortening and seating of anchorage.

8. PERMISSIBLE STRESSES IN PRESTRESSING STEEL

Maximum jack pressure shall not exceed 90 per cent of 0.1% proof stress. For the purpose of this Clause 0.1% proof stress shall be taken as equal to 85% of minimum Ultimate Tensile Strength (UTS).

9. SECTION PROPERTIES

9.1. For members consisting of precast as well as cast-in-situ units, due consideration shall be given to the different moduli of elasticity of concrete in the precast and in-situ portions.

9.2. Openings in Concrete Section

For the purpose of determining the flexural stresses both prior to and after grouting of the cables or tendons, the properties of the section such as area, position of centroid and moment of inertia may be based upon the full section of the concrete without deducting for the area of longitudinal openings left in the concrete for prestressing tendons, cable ducts or sheaths. No allowance for the transformed area of the prestressing tendons shall, however, be made.

Deduction shall be made for the holes of transverse prestressing tendons at sections where they occur, for determining the stresses before grouting of these holes.

9.3. Minimum Dimensions

9.3.1. 'T' beams

9.3.1.1. The thickness of the web shall not be less than 200 mm plus diameter of duct hole. Where cables cross within the web, suitable increase in the thickness over the above value shall be made.

9.3.1.2. The effective width of the flange of a 'T' beam shall conform to Clause 305.15.2 of IRC:21.

9.3.1.3. The minimum thickness of the deck slab including that at cantilever tips shall be 200 mm.

9.3.1.4. In case of multi-beam arrangement, at least two cross girders, one at each support, shall be provided. For bridges having beam and slab type of superstructure, the number of longitudinal beams shall not be less than 3 except for single lane and pedestrian bridges. The depth of the end cross girders shall be suitably adjusted to allow access for proper inspection of bearings and to facilitate positioning of jacks for future lifting up of the super-structure. The thickness of cross girders shall not be less than the minimum web thickness of longitudinal girders.

9.3.1.5. In case of composite construction with prestressed concrete girders and RCC deck slab, the soffit of deck slab shall be in line with the top of the flange of the girders.

9.3.2. Box girders

9.3.2.1. The thickness of the web shall not be less than $d/36$ plus twice the clear cover to the reinforcement plus diameter of the duct hole where 'd' is the overall depth of the box girder measured from the top of the deck slab to the bottom of the soffit or 200 mm plus the diameter of duct holes,

whichever is greater. Where cables cross within the web, suitable increase in the thickness over the above shall be made.

In case of cast in situ cantilever construction, if the prestressing cables are anchored in the web, the web shall be locally thickened to not less than 350 mm nor less than that recommended by the prestressing system manufacturer, subject to design requirements.

9.3.2.2. The thickness of the bottom flange of box girder shall be not less than 1/20th of the clear web spacing at the junction with bottom flange or 200 mm whichever is more. For top flange minimum thickness shall be as per Clause 9.3.1.3.

9.3.2.3. For top and bottom flange having prestressing cables, the thickness of such flange shall not be less than 150 mm plus diameter of duct hole.

9.3.2.4. In box girders, effective and adequate bond and shear resistance shall be provided at the junction of the web and the slabs. The slabs may be considered as an integral part of the girder and the entire width may be assumed to be effective in compression.

For very short spans or where web spacing is excessive or where overhangs are excessive, analytical investigation shall be made to determine the effective flange width.

9.3.2.5. For cantilever construction, preference shall be given to box type cross section with diaphragms provided at supports. Sudden change in depth of superstructure should not be permitted. For reducing the thermal effect suitable ventilation should be provided in box sections.

9.3.2.6. Haunches of minimum size of 300 mm (horizontal) and 150 mm (vertical) shall be provided at the four extreme

inner corners of the box section. For all other corners fillets of suitable size may be provided.

9.3.2.7. The minimum clear height inside the box girders shall be 1.5 m to facilitate inspection.

9.4. Diaphragms/Cross Girders

Diaphragms shall be provided depending upon design requirements. The thickness of diaphragms shall not be less than the minimum web thickness.

10. MODULI OF ELASTICITY

10.1. Modulus of Elasticity of Steel (E_s)

10.1.1. For the purpose of design the following nominal values of modulus of elasticity can be assumed except where the manufacturers certified values or test results are available:

Table 1

Type of steel	Modulus of elasticity MPa
Plain hard-drawn wires (conforming to IS:1785 and IS:6003)	2.1×10^5
High tensile steel bars rolled or heat treated (conforming to IS:2090)	2.0×10^5
Strands (conforming to IS:6006)	1.95×10^5

10.1.2. Representative values of modulus of elasticity as supplied by the manufacturers or as per test results based on one test of 3 samples for every lot of 10 tonnes or part thereof shall be used for verification of the elongation calculations.

10.2. Modulus of Elasticity of Concrete (E_c)

Unless otherwise determined by tests, the modulus of elasticity, E_c of concrete shall be assumed to have a value

$$E_c = 5000 \sqrt{f_{ck}} \text{ MPa}$$

The value of the modulus of elasticity E_{cj} of the concrete at j days may be taken to be.

$$E_{cj} = 5000 \sqrt{f_{cj}} \text{ MPa}$$

11. LOSSES IN PRESTRESS

Decrease in prestress in steel due to friction, seating of anchorages and elastic shortening shall be deemed to be instantaneous, while that due to creep, shrinkage and relaxation of steel is time dependant. Both losses shall be calculated on the following basis:

11.1. Elastic Shortening

The loss due to elastic shortening of concrete shall be computed based on the sequence of tensioning. However, for design purposes, the resultant loss of prestress in tendons tensioned one by one may be calculated on the basis of half the product of modular ratio and the stress in concrete adjacent to the tendons averaged along the length. Alternatively the loss of prestress may be computed exactly based on sequence of stressing.

11.2. Creep of Concrete

The strain due to creep of concrete shall be taken as specified in Table 2.

Table 2

Maturity of concrete at the time of stressing as a percentage of f_{ck}	Creep strain per 10 MPa
40	9.4×10^{-4}
50	8.3×10^{-4}
60	7.2×10^{-4}
70	6.1×10^{-4}
75	5.6×10^{-4}
80	5.1×10^{-4}
90	4.4×10^{-4}
100	4.0×10^{-4}
110	3.6×10^{-4}

- Notes: (i) The creep strain during any interval may be taken as the strain due to a sustained stress equal to the arithmetic mean of the initial and the final stress occurring during that interval.
- (ii) The stress for the calculation of the loss due to creep shall be taken as the stress in concrete at the centroid of the prestressing steel. Variation in stress, if any, along the centroid of the prestressing steel, may be accounted for.
- (iii) Values of creep strain for intermediate figures for the maturity of concrete at the time of stressing may be interpolated taking a linear variation between the values given above.
- (iv) The above values are for Ordinary Portland Cement.

11.3. Shrinkage of Concrete

The loss in prestress in steel, due to shrinkage of concrete shall be estimated from the values of strain due to residual shrinkage given in Table 3.

11.4. Relaxation of Steel

Relaxation of steel shall invariably be verified by testing to ascertain conformance to the respective codes for prestressing

Table 3

Age of concrete at the time of stressing, in days	Strain due to residual shrinkage
3	4.3×10^{-4}
7	3.5×10^{-4}
10	3.0×10^{-4}
14	2.5×10^{-4}
21	2.0×10^{-4}
28	1.9×10^{-4}
90	1.5×10^{-4}

- Notes: (i) Values for intermediate figures for any age of concrete may be interpolated taking a linear variation between the values given.
- (ii) The above are for Ordinary Portland Cement.

steel as per Clause 3.5.1. For calculation of permissible temporary stress in concrete as per Clause 7.1 losses due to relaxation of steel shall be taken in accordance with Table 4A and 4B. For calculation of stress in service condition, long term relaxation loss values occurring at about 0.5×10^6 hours shall be considered, which shall be taken as 3 times the 1000 hour value given in Table 4A.

Table 4A

Relaxation loss at 1000 hours at $20^\circ\text{C} \pm 2^\circ\text{C}$ (as % of initial stress)

Initial stress	Relaxation loss for Normal relaxation steel (%)	Relaxation loss for low relaxation steel (%)
0.5 fp	0	0
0.6 fp	2.5	1.25
0.7 fp	5.0	2.5
0.8 fp	9.0	4.5

- Notes: (i) For intermediate values linear interpolation may be done
- (ii) fp = Minimum Ultimate Tensile Stress (UTS) of steel

Table 4B

Relation between relaxation losses and time upto 1000 hours.

Time in Hours	1	5	20	100	200	500	1000
Relaxation loss as % of loss at 1000 hrs	15	25	35	55	65	85	100

11.5. Losses Due to Seating of Anchorages

Depending upon the type of post tensioning, losses in prestress occur due to slip of wires, draw-in of male cones, strains in anchorage, the value of which shall be as per tests or manufacturer's recommendations and duly accounted, for considering reverse friction near the anchorage ends. For this purpose the values of co-efficient of friction and wobble co-efficient shall be taken same as those stipulated for positive friction.

11.6. Friction Losses

Steel stress in prestressing tendons $\sigma_{po}(x)$ at any distance x from the jacking end can be calculated from the formula

$$\sigma_{po} = \sigma_{po}(x) e^{(\mu\theta + kx)}$$

- Where
- σ_{po} = the steel stress at the jacking end
 - e = the base of Napierian Logarithms
 - μ = the co-efficient of friction
 - θ = the cumulative angle in radians through which the tangent to the cable profile has turned between the points of operation of σ_{po} and $\sigma_{po}(x)$.
 - $\sigma_{po}(x)$ = the steel stress at a point, distant 'x' from the jacking end
 - k = the wobble co-efficient per metre length of steel
 - x = the distance between points of operation of σ_{po} and $\sigma_{po}(x)$ in metres.

The value of μ and k given in Table 5 may be adopted for calculating the friction losses.

Table 5

Type of high tensile steel	Type of duct or sheath	Values recommended to be used in design	
		k per metre	μ
Wire cables	Bright metal	0.0091	0.25
	Galvanized	0.0046	0.2
	Lead coated	0.0046	0.18
	Unlined duct in concrete	0.0046	0.45
Uncoated stress relieved strands	Bright metal	0.0046	0.25
	Galvanized	0.0030	0.20
	Lead coated	0.0030	0.18
	Unlined duct in concrete	0.0046	0.50
	Corrugated HDPE	0.0020	0.17

- Notes:
- (i) Values to be used in design may be altered to the values observed, on satisfactory evidence in support of such values.
 - (ii) For multi-layer wire cables with spacer plates providing lateral separation, the value of μ may be adopted on the basis of actual test results.
 - (iii) When the direction of friction is reversed, the index of 'e' in the above formula shall be negative.
 - (iv) The above formula is of general application and can be used for estimation of friction between any two points along the tendon distant 'x' from each other.

The values of μ and k used in design shall be indicated on the drawings for guidance in selection of the material and the methods that will produce results approaching the assumed values.

11.7. For structures constructed by segmental construction or other complex construction methods which

require accurate determination and detailed information of time dependent effects, specialist literature may be referred to.

12. ULTIMATE STRENGTH

A prestressed concrete structure and its constituent members shall be checked for failure conditions at an ultimate load of $1.25 G + 2 SG + 2.5 Q$ under moderate condition and $1.5 G + 2 SG + 2.5 Q$ under severe exposure conditions where G , SG and Q denote permanent load, superimposed dead load and live load including impact respectively. The superimposed dead load shall include dead load of precast footpath, hand rails, wearing course, utility services, kerbs etc. For sections, where the dead load causes effects opposite to those of live load, the sections shall also be checked for adequacy for a load of $G + SG + 2.5 Q$.

13. CALCULATION OF ULTIMATE STRENGTH

Under ultimate load conditions, the failure may either occur by yielding of the steel (under-reinforced section) or by direct crushing of the concrete (over-reinforced section). Ultimate moment of resistance of sections, under these two alternative conditions of failure shall be calculated by the following formulae and the smaller of the two values shall be taken as the ultimate moment of resistance for design :

- (i) Failure by yield of steel (under-reinforced section)

$$M_{ult} = 0.9 d_b A_s f_p$$

Where A_s = the area of high tensile steel
 f_p = the ultimate tensile strength for steel without definite yield point or yield stress or stress at 4 per cent elongation whichever is higher for steel with a definite yield point.
 d_b = the depth of the beam from the maximum compression edge to the centre of gravity of the steel tendons.

Non-prestressed reinforcement may be considered as contributing to the available tension for calculation of the ultimate moment of resistance in an amount equal to its area times its yield stress, provided such reinforcement is welded or has sufficient bond under conditions of ultimate load.

- (ii) Failure by crushing of concrete

$$M_{ult} = 0.176 b d_b^2 f_{ck}$$

for a rectangular section

$$M_{ult} = 0.176 b d_b^2 f_{ck} + \frac{2}{3} 0.8 (B_f - b) \left(d_b - \frac{t}{2} \right) x t f_{ck}$$

for a Tee beam

Where b = the width of rectangular section or web of a Tee beam

B_f = the width of flange of Tee beam

t = the thickness of flange of a Tee beam

14. SHEAR AND TORSION

14.1. Shear

14.1.1. The calculations for shear are only required for the Ultimate Load.

At any section the ultimate shear resistance of the concrete alone, V_c shall be considered for the section both uncracked (see Clause 14.1.2) and cracked (see Clause 14.1.3) in flexure irrespective of the magnitude of M_p and the lesser value taken and, if necessary, shear reinforcement (see Clause 14.1.4) provided.

For a cracked section, the conditions of maximum shear with co-existent bending moment and maximum bending moment with co-existent shear shall both be considered.

The effect of the vertical component of the bottom flange force in members of variable depth may also be considered where applicable. While calculating this component the design moment to be considered shall be concomitant with the design shear force being considered.

14.1.2. Sections uncracked in flexure

14.1.2.1. The ultimate shear resistance of a section uncracked in flexure, V_{co} , corresponds to the occurrence of a maximum principal tensile stress, at the centroidal axis of the section, of $f_t = 0.24 f_{ck}$.

In the calculation of V_{co} , the value of prestress at the centroidal axis has been taken as $0.8 f_{cp}$. The value of V_{co} is given by :

$$V_{co} = 0.67 bd \sqrt{f_t^2 + 0.8 f_{cp} f_t}$$

- Where * b = width in the case of rectangular member and width of the rib in the case of T, I and L beams
 d = overall depth of the member
 f_t = maximum principal tensile stress given by $0.24 \sqrt{f_{ck}}$
 f_{cp} = compressive stress at centroidal axis due to prestress taken as positive.

*Where the position of a duct coincides with the position of maximum principal tensile stress, e.g., at or near the junction of flange and web near a support, the value of b should be reduced by the full diameter of the duct if ungrouted and by two-thirds of the diameter if grouted.

In flanged members where the centroidal axis occurs in the flange, the principal tensile stress should be limited to $0.24 \sqrt{f_{ck}}$ at the intersection of the flange and web; in this calculation, 0.8 of the stress due to prestress at this intersection may be used in calculating V_{co} .

For a section uncracked in flexure and with inclined

tendons or vertical prestress, the component of prestressing force normal to the longitudinal axis of the member may be added to V_{co} .

14.1.2.2. For bridge decks with precast prestressed beams and cast-in-situ deck slab, V_{co} can be evaluated as given below:

- M_{pc} = ultimate design moment acting on the precast section alone
 V_{cl} = ultimate design shear force acting on the precast section alone
 I_p = second moment of area of precast section alone
 I_c = second moment of area of composite section
 $(Ay)_p$ = first moment of area above composite centroid for precast section alone
 $(Ay)_c$ = first moment of area above composite centroid for composite section
 f_{cm} = stress at composite centroid due to M_{pc}
 f_{cp} = stress at composite centroid due to prestress
 f_{cp} = $0.8 f_{cp} + f_{cm}$
 f_s = stress at composite centroid due to V_{cl}
 = $\frac{V_{cl} (Ay)_p}{(I_p b)}$, if $f_s \geq f_t$ then section revision is required
 V_{c2} = additional ultimate shear force which can be carried by the composite section before the principal tensile stress at composite centroid reaches $f_t = 0.24 (f_{ck})^{1/2}$
 = $\frac{(I_c b)}{(Ay)_c} [(f_t^2 + f_{cp} f_t)^{1/2} - f_t]$
 $V_{co} = V_{cl} + V_{c2}$

14.1.3. **Sections cracked in flexure** : The ultimate shear resistance of a section cracked in flexure, V_{cr} may be calculated using the equation given below :

$$V_{cr} = 0.037 b d_b \sqrt{f_{ck} + \frac{M_t}{M}} V$$

Where d_b = is the distance from the extreme compression fibre

- to the centroid of the tendons at the section considered;
- M_t = is the cracking moment at the section considered, $M_t = (0.37 \sqrt{f_{ck}} + 0.8 f_{pr})I/y$ in which f_{pr} is the stress due to prestress only at the tensile fibre distance y from the centroid of the concrete section which has a second moment of area I ;
- V and M = are the shear force and corresponding bending moment at the section considered due to ultimate loads;
- V_{cr} = should be taken as not less than $0.1 bd \sqrt{f_{ck}}$. The value of V_{cr} calculated at a particular section may be assumed to be constant for a distance equal to $d_b/2$, measured in the direction of increasing moment from that particular section.

For a section cracked in flexure and with inclined tendons, the component of prestressing forces normal to the longitudinal axis of the member should be ignored.

14.1.4. **Shear reinforcement** : When V , the shear force due to the ultimate load is less than $V_c/2$ then no shear reinforcement need be provided. A minimum shear reinforcement shall be provided when V is greater than $V_c/2$ in the form of links such that

$$\frac{A_{sv}}{S_v} \times \frac{0.87 F_{yv}}{b} = 0.4 MPa \quad \dots (1)$$

When the shear force V , due to the ultimate loads exceeds V_c , the shear reinforcement provided shall be such that

$$\frac{A_{sv}}{S_v} = \frac{V - V_c}{0.87 f_{yv} d_t} \quad \dots (2)$$

- Where V_c = is the shear force that can be carried by the concrete
- f_{yv} = is the yield strength of the links/shear reinforcement or 0.2 per cent proof stress which should be taken as not greater than 415 MPa
- A_{sv} = is the cross-sectional area of the two legs of a link
- S_v = is the link spacing along the length of member
- d_t = is the depth from the extreme compression fibre either to the longitudinal bars having diameter not less than the link bar over which the link will pass or to the centroid of the tendons, whichever is greater.

In beams, at both corners in the tensile zone, a link shall pass round a longitudinal bar, a tendon or a group of tendons having a diameter not less than the link diameter. A link shall extend as close to the tension and compression faces as possible, with due regard to cover. The links provided at a cross section shall between them enclose all the tendons and additional reinforcement provided at the cross section and shall be adequately anchored, Fig. 2 (i-iii). In no case shear reinforcement provided shall be less than that required as per equation (1) above when V is greater than $V_c/2$.

14.1.5. **Maximum shear force** : In no circumstances shall the shear force ' V ', due to ultimate loads, exceed the appropriate value given in Table 6 multiplied by bd_b , where ' b ' is as defined in sub-clause 14.1.2, less either the diameter of the duct for ungrouted or two-thirds the diameter of the duct for grouted ducts and ' d_b ' is the distance from the compression face to the centroid of the actual steel area in tensile zone but not less than 0.80 times the overall depth of the member.

The shear force V should include an allowance for prestressing only for sections uncracked in flexure (see Clause 14.1.2).

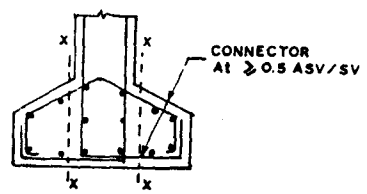

Connector details tension flange (bulb) of T-beam (i)

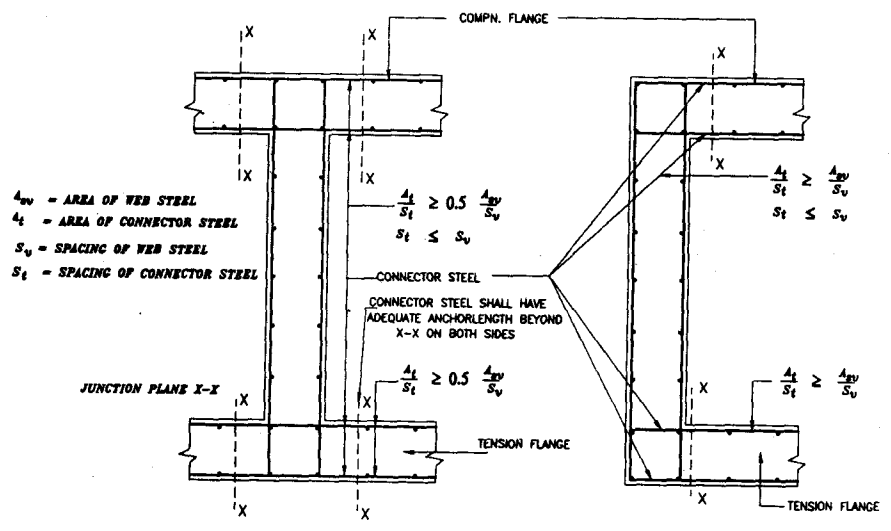

Connector details at junction of intermediate web and flanges of box girder (ii)

Connector details at junction of end web and flanges of box girder (iii)

Fig. 2. Connector reinforcement for compression flange and tension flange

Table 6. Maximum Shear Stress

	Concrete Grade						
	30	35	40	45	50	55	60
Maximum Shear Stress	MPa 4.1	MPa 4.4	MPa 4.7	MPa 5.0	MPa 5.3	MPa 5.5	MPa 5.8

Note : For intermediate values linear interpolation may be done.

14.2. Torsional Resistance of Beams

14.2.1. **General** : Torsion does not usually decide the dimensions of members, therefore, torsional design should be carried out as a check after the flexural design. In general, where the torsional resistance or stiffness of members has not been taken into account in the analysis of the structure no specific calculations for torsion will be necessary, adequate control of any torsional cracking being provided by the required nominal shear reinforcement. Therefore, provisions made in the clause are to be followed when the effect of torsion is appreciable. Alternative methods of designing members subjected to combined bending, shear and torsion could also be used provided the rationality of the method adopted is justified.

14.2.2. **Stresses and reinforcement** : Calculations for torsion are required only for ultimate loads and the torsional shear stresses should be calculated assuming a plastic stress distribution. Where the torsional shear stress V_t exceeds the value V_{tc} from Table 7, reinforcement shall be provided. In no case, shall the sum of shear stresses resulting from shear force and torsion $(V + V_t)$ exceed the value of V_{tu} from Table 7 nor in the case of small sections ($Y_t < 550$ mm) should the torsional

IRC : 18-2000

shear stress, V_p exceed $V_{tu} \times Y_1/550$ where Y_1 is the larger dimension of a link.

Torsion reinforcement shall consist of rectangular effectively closed links together with longitudinal reinforcement. This reinforcement is addition to that required for shear or bending.

Table 7. Ultimate Torsion Shear Stress

	Concrete Grade						
	30	35	40	45	50	55	60
V_{tc}	0.37	0.40	0.42	0.42	0.42	0.42	0.42
V_{tu}	4.10	4.45	4.75	5.03	5.30	5.56	5.81

14.2.3. Computation of torsional stresses for various cross sections

14.2.3.1. Rectangular section

$$V_t = \frac{2T}{(h_{min}^2) \times (h_{max} - \frac{h_{min}}{3})}$$

Where T = is the torsional moment due to ultimate loads
 h_{min} = is the smaller dimension of the section
 h_{max} = is the larger dimension of the section

Torsional reinforcement should be provided such that

$$\frac{A_{sv}}{S_v} \geq \frac{T}{0.8 X_1 Y_1 (0.87 f_{yv})}$$

$$A_{SL} \geq \frac{A_{sv}}{S_v} (X_1 + Y_1) \left(\frac{f_{yv}}{f_{yL}} \right)$$

Where A_{sv} = is the total area of legs of closed links at a section
 A_{SL} = is the area of longitudinal reinforcement

- f_{yL} = is the yield strength of longitudinal reinforcement which should not be taken greater than 415 MPa
- f_{yv} = is the yield strength of links
- S_v = is the spacing of the links
- X_1 = is the smaller dimension of the link measured between centres of legs
- Y_1 = is the larger dimension of the link measured between centres of legs.

To prevent a detailing failure the closed links shall be detailed to have minimum cover and a pitch less than the smallest of $(X_1 + Y_1)/4$, 16 times longitudinal corner bar diameters and 200 mm. The longitudinal reinforcement shall be positioned uniformly such that there is a bar at each corner of the links. The diameter of the corner bars shall be not less than the diameter of the links.

14.2.3.2. T, L and I sections : Such sections shall be divided into component rectangles for purpose of torsional design. This shall be done in such a way as to maximize the function $\sum (h_{max} \times h_{min}^3)$ where h_{max} and h_{min} are the larger and smaller dimensions of each component rectangle. Each rectangle shall then be considered subject to a torque :

$$\frac{T(h_{max} \times h_{min}^3)}{\sum (h_{max} \times h_{min}^3)}$$

Reinforcement shall be so detailed as to tie the individual rectangles together. Where the torsional shear stress in a rectangle is less than V_{tc} no torsional reinforcement need to be provided in that rectangle.

14.2.3.3. Box section

$$V_t = T/2h_{wo} A_o$$

Where h_{wo} = is the wall thickness of members where the stress is determined;

A_o = is the area enclosed by the centre line of members forming the box.

Torsional reinforcement is to be provided such that

$$\frac{A_{sv}}{S_v} \geq \frac{T}{A_o(0.87 f_{yv})}$$

$$A_{SL} \geq \frac{A_{sv}}{S_v} \left(\frac{\text{Perimeter of } A_o}{2} \right) \times \frac{f_{yv}}{f_{yt}}$$

The detailing requirements of Clause 14.2.3.1, should still be observed. In detailing the longitudinal reinforcement to cater for torsional stresses account may be taken of those areas of the cross section subjected to simultaneous flexural compressive stresses and a lesser amount of reinforcement in the compressive zone may be taken as :

$$\text{Reduction in steel area} = f_{cav} \times \frac{\text{(Area of section subject to flexural compression)}}{0.87 f_{yc}}$$

Where f_{cav} = is the average compressive stress in the flexural compressive zone, and

f_{yc} = is the yield stress of longitudinal steel in compression.

15. MINIMUM REINFORCEMENT

15.1. General

The quantity of untensioned steel required for design or constructional purposes shall not be less than the minimum stipulated in Clauses 15.2 to 15.4. Various types of minimum steel requirements need not be added together. Bars in such reinforcement shall, however, not be placed more than 200 mm apart. The minimum diameter shall not be less than 10 mm for

severe condition of exposure and 8 mm for moderate condition of exposure.

In case of in-situ segmental construction for bridges located in marine environment continuity of untensioned reinforcement from one segment to the next shall be ensured.

15.2. In the vertical direction, a minimum reinforcement shall be provided in the bulb/web of the beams/rib of box girders, such reinforcement being not less than 0.3 per cent of the cross sectional area of the bulb/web in plan for mild steel and 0.18 per cent for HYSD bars respectively. Such reinforcement shall be as far as possible uniformly spaced along the length of the web. In the bulb portion, the cross sectional area of bulb in plan shall be taken.

In all the corners of the section, these reinforcements should pass round a longitudinal bar having a diameter not less than that of the vertical bar or round a group of tendons. For tee-beams, the arrangement in the bulb portion shall be as shown in Fig. 2.

15.3. Longitudinal reinforcements provided shall not be less than 0.25 per cent and 0.15 per cent of the gross cross sectional area of the section for mild steel and HYSD bars respectively, where the specified grade of concrete is less than M 45. In case the grade of concrete is M 45 or more, the provision shall be increased to 0.3 per cent and 0.18 per cent respectively. Such reinforcement shall as far as possible be evenly spaced on the periphery. Non-prestressed high tensile reinforcement can also be reckoned for the purpose of fulfilling the requirement of this clause.

15.4. For solid slabs and top and bottom slabs of box girders, the top and underside of the slabs shall be provided with

reinforcement consisting of a grid formed by layers of bars. The minimum steel provided shall be as follows :

- (i) **For solid slabs and top slab of box girders:** 0.3 per cent and 0.18 per cent of the gross cross sectional area of the slab for MS and HYSD bars respectively, which shall be equally distributed at top and bottom.
- (ii) **For soffit slab of box girders:** The longitudinal steel shall be at least 0.18 per cent and 0.3 per cent of sectional area for HYSD and MS bars respectively. The minimum transverse reinforcement shall be 0.3 per cent and 0.5 per cent of the sectional area for HYSD and MS bars respectively. The minimum reinforcement shall be equally distributed at top and bottom.

15.5. For cantilever slab minimum reinforcement of 4 nos. of 16 mm dia HYSD bars or 6 nos. of 16 mm dia MS bars should be provided with minimum spacing at the tip divided equally between the top and bottom surface parallel to support.

N.B. Notwithstanding the nomenclature "untensioned steel", this provision of reinforcement may be utilised for withstanding all action affects, if necessary.

16. COVER AND SPACING OF PRESTRESSING STEEL

16.1. Wherever prestressing cable is nearest to concrete surface, the minimum clear cover measured from outside of sheathing, shall be 75 mm.

16.2. The minimum clear cover to untensioned reinforcement including links and stirrups shall be as per Clause 304.3 of IRC:21.

16.3. A minimum clear distance of 50 mm or diameter of the duct, whichever is greater, shall be maintained between individual cables when grouping of cables is not involved.

16.4. Grouped Cables

16.4.1. Grouping of cables shall be avoided to the extent possible. If unavoidable, only vertical grouping of cables, upto 2 cables may be permitted as shown in Fig. 3. The minimum clear spacing between groups shall be diameter of the duct or 50 mm, whichever is greater.

Note : In case of severe conditions of exposure, grouping of cables should be altogether avoided. This may be achieved by the use of high capacity strands.

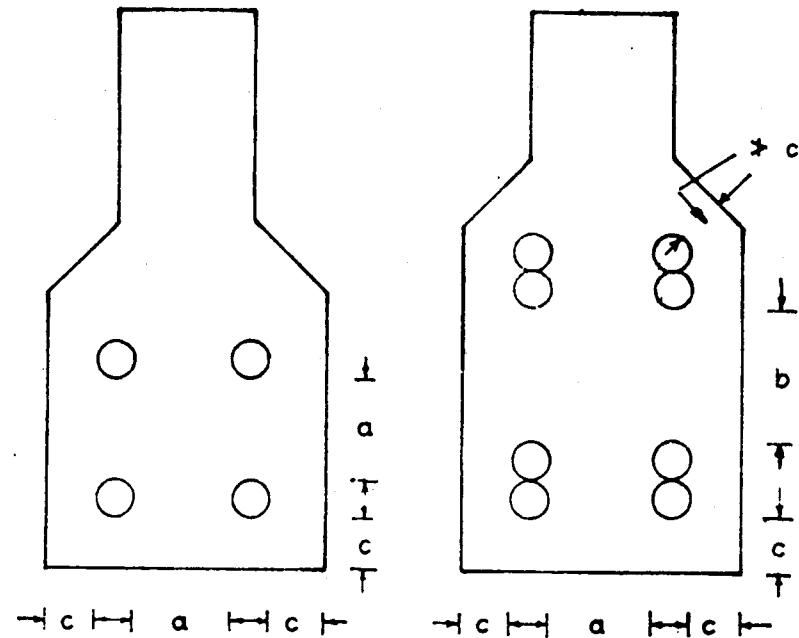

a, b \geq 50 mm or diameter of duct whichever is greater, C \geq 75 mm

Fig. 3.

16.4.2. Individual cables or ducts of grouped cables shall be deflected or draped in the end portions of members. The clear spacing between cables or ducts in the end one metre of the members as specified in Clause 16.3 shall be maintained.

16.5. The placement of cables or ducts and the order of stressing and grouting shall be so arranged that the prestressing steel, when tensioned and grouted, does not adversely affect the adjoining ducts.

16.6. All cables shall be threaded by threading machine or any contrivance into preformed ducts. Wherever two stage prestressing is contemplated, a dummy core shall be provided in the preformed ducts of the second stage cables, which shall be pulled out after the first stage prestressing and grouting is over. Thereafter, the cables for the second stage shall be threaded into the preformed ducts. Where prestressing in more than two stages is contemplated, the above procedure shall be followed for subsequent stage cables also.

Stressing of cable/part of cable to avoid shrinkage cracks shall not be treated as a stage.

17. END BLOCKS

17.1. End block shall be designed to distribute the concentrated prestressing force at the anchorage. It shall have sufficient area to accommodate anchorages at the jacking end and shall preferably be as wide as the narrowest flange of the beam. Length of end block in no case shall be less than 600 mm nor less than its width. The portion housing the anchorages shall as far as possible be precast.

17.2. The bursting forces in the end blocks, should be assessed on the basis of the ultimate tensile strength. The bursting tensile force, F_{bst} existing in an individual square end

block loaded by a symmetrically placed square anchorage or bearing plate, may be derived from Table 8.

Where $2 Y_o$ = is the side of end block
 $2 Y_{po}$ = is the side of loaded area
 P_k = is the load in the tendon assessed as above
 F_{bst} = is the bursting tensile force.

Table 8. Design Bursting Tensile Forces in End Blocks

Y_{po}/Y_o	0.3	0.4	0.5	0.6	0.7
F_{bst}/P_k	0.23	0.20	0.17	0.14	0.11

- Notes : (i) For intermediate values linear interpolation may be made.
 (ii) The values in the table above generally hold good for internal anchorages. For external anchorages the design force may be increased by 10 per cent.

This force, F_{bst} will be distributed in a region extending from $0.2 Y_o$ to $2 Y_o$ from the loaded face of the end block as shown in Fig. 4.

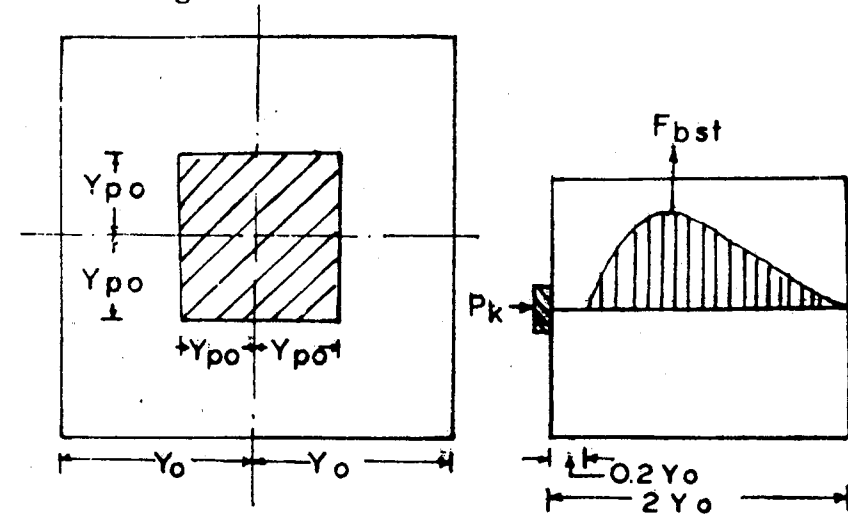

Fig. 4.

Reinforcement provided in this region to sustain the bursting tensile force may be calculated based on a tensile strength of $0.87 f_y$, except that the stress should be limited to a value corresponding to a strain of 0.001 when the concrete cover to the reinforcement is less than 50 mm.

In the rectangular end blocks, the bursting tensile forces in the two principal directions should be assessed on the similar basis as in Table 8.

When circular anchorages or bearing plates are used, the side of the equivalent square area should be derived.

Where groups of anchorages or bearing plates occur, the end block should be divided into a series of symmetrically loaded prisms and each prism treated in the above manner. In detailing the reinforcement for the end block as a whole, it is necessary to ensure that the groups of anchorages are appropriately tied together. Special attention should be paid to end blocks having a cross section different in shape from that of the general cross section of the beam and reference should be made to specialist literature. Compliance with the above requirements will generally ensure that bursting tensile forces along the loaded axis are provided for. In case where large concentrated tendon forces are involved alternative methods of design based on specialist literature and manufacturer's data may be more appropriate.

17.3. Consideration should also be given to the spalling tensile stresses that occur in end blocks. Where the anchorage or bearing plates are highly eccentric, these stresses reach a maximum at the loaded face. The end face of anchorage zone shall be continuously reinforced to prevent edge spalling.

Reinforcement shall be placed as close to the end face as possible.

18. THICKENING OF WEBS OF GIRDERS

The thickening of webs of girders towards the end blocks shall be achieved gradually with a splay in plan of not steeper than 1 in 6. Suitable thickening for isolated anchorages away from the end blocks shall be made whenever necessary to reduce stress concentration.

19. ANCHORAGE OF CABLES AND STRESSING

Anchorage of cables in the top deck surface shall not be permitted. All anchorages shall be properly sealed after prestressing and grouting operations. All wires/strands in one cable should be stressed simultaneously by using multi-stressing jack.

20. SPLAY OF CABLES IN PLAN AND MINIMUM RADIUS OF CABLES IN ELEVATION

The splay of cables in plan, for bringing them from their position in the bottom flange at mid-span into the web towards the supports shall not be more than 1 in 6. The points of splay shall be suitably staggered on both sides of the longitudinal centre line of the web of the girder. The minimum radius of curvature, spacing and cover for curved cables shall be specified to ensure that bursting of the side cover both perpendicular to the plane of curvature and in the plane of curvature of the ducts does not take place. Guidance in this regard may be taken from BS:5400: Part 4: (Appendix-D) subject to spacing and cover stipulations given in Clause 16.

21. SLENDER BEAMS

Slender beams are those in which :

- (a) ratio of span to width of top flange is more than 60, and
- (b) ratio of width of top flange to the depth of beam is less than 1/4.

For such beams permissible stress shall be reduced suitably and they shall also be provided with adequate temporary restraints during handling and erection which should be investigated.

22. EMERGENCY CABLES/STRANDS

Besides the design requirements, additional cables/strands shall be symmetrically placed in the structure so as to be capable of generating prestressing force of about 4 per cent of the total design prestressing force in the structure. Only those cables which are required to make up the deficiency shall be stressed and the remainder pulled out and the duct hole shall be grouted.

23. STORAGE AND HANDLING OF PRESTRESSING MATERIALS

A recommended practice for storage and handling of prestressing material is given in *Appendix-3*.

24. PRESTRESSING OPERATION

A recommended practice for prestressing operations is given at *Appendix-4*.

25. GROUTING OF CABLES

A recommended practice for grouting of cable is given at *Appendix-5*.

TESTS ON SHEATHING DUCTS

- (1) All tests specified below shall be carried out on the same sample in the order given below.
- (2) At least 3 samples for one lot of supply (not exceeding 7000 metre length) shall be tested.

3. WORKABILITY TEST

A test sample 1100 mm long is soldered to a fixed base plate with a soft solder (Fig. 1A-1). The sample is then bent to a radius of 1800 mm alternately on either side to complete 3 cycles.

Thereafter, the sealing joints will be visually inspected to verify that no failure or opening has taken place.

4. TRANSVERSE LOAD RATING TEST

The test ensures that stiffness of the sheathing is sufficient to prevent permanent distortion during site handling.

The sample is placed on a horizontal support 500 mm long so that the sample is supported at all points of outward corrugations.

A load as specified in Table below is applied gradually at the centre of the supported portion through a circular contact surface of 12 mm dia. Couplers shall be placed so that the load is applied approximately at the centre of two corrugations, Fig. 1A-2. The load as specified below is applied in increments.

5. TENSION LOAD TEST

The test specimen is subjected to a tensile load. The hollow core is filled with a wooden cylindrical piece having a diameter of 95 per cent of the inner dia of the sample to ensure circular profile during test loading, Fig. 1A-3.

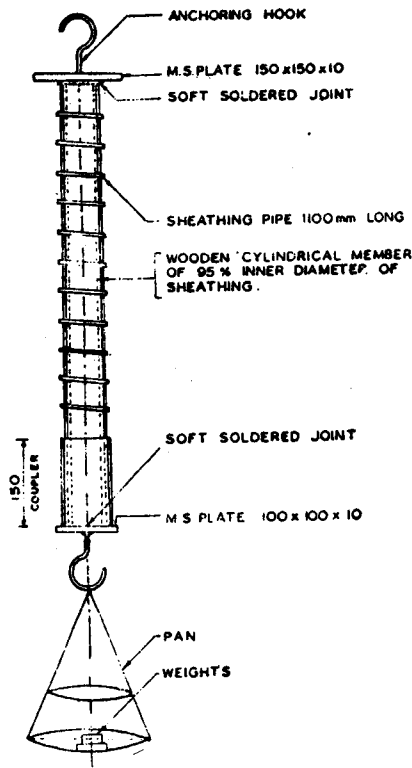

Fig. 1A-3. Tension load test

A coupler is screwed on and the sample loaded in increments, till specified load. If no deformation of the joints nor slippage of couplers is

noticed, the test shall be considered satisfactory :

Dia in mm	Load
25 upto 35	300 N
More than 35 upto 45	500 N
More than 45 upto 55	800 N
More than 55 upto 65	1100 N
More than 65 upto 75	1400 N
More than 75 upto 85	1600 N
More than 85 upto 90	1800 N

6. WATER LOSS TEST

The sample is sealed at one end. The sample is filled with water and after sealing, the end is connected to a system capable of applying a pressure of 0.05 MPa, Fig. 1A-4 and kept constant for 5 minutes, hand pump and pressure gauge or stand pipe system can be used.

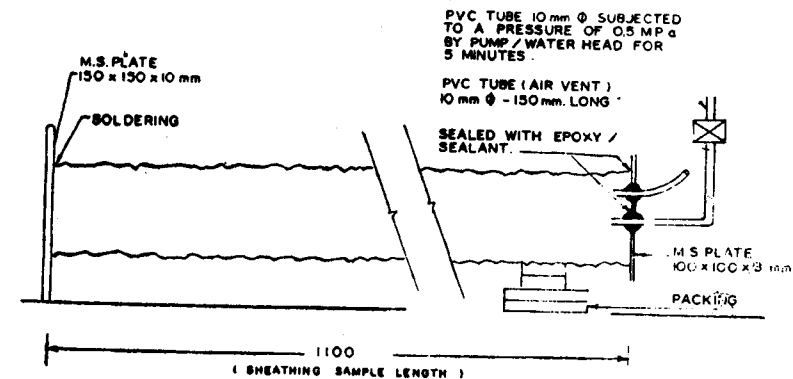

Fig. 1A-4. Test for water loss study

The sample is acceptable if the water loss does not exceed 1.5 per cent of the volume. The volume is worked out as follows:

Another sample 500 mm long is sealed at one end and the volume of hollow space arrived at by pouring water from a measuring cylinder.

The computation of relative profile volume is worked out as follows:

- V_a - Premeasured quantity of water in a measuring cylinder
 V_b - Balance quantity of water left in the cylinder after completely filling of the test sample

$$\text{Actual Volume } 'V_p' = V_a - V_b$$

$$\text{Relative Profile Volume} = V_p - \frac{\pi \phi^2 l}{4} \text{ cm}^3/\text{cm}^2$$

Where l is length of specimen and ϕ internal nominal dia. of sheathing.

TESTS ON CORRUGATED HDPE SHEATHING DUCTS

The additional acceptance tests for the prestressing systems employing corrugated HDPE ducts shall cover the following two tests:

1. BOND TEST

Object: To establish satisfactory bond characteristics between the tendon and concrete, in the ultimate condition.

Equipment

- * 3 nos. similar reinforced concrete beams with a HDPE duct of length equal to 40 times the duct diameter,
- * Prestressing tendon of adequate length for stressing and for embedding in the beam,
- * Tendon anchorage system,
- * Load cells and meters,
- * Grout constituents.

Method: Cast an adequately reinforced beam to withstand the prestressing operation and of length to embed 40 times the dia. of duct to suit the tendon to be adopted. Introduce the strands of the tendon by spacing them parallel by means of ply-spacers as shown in Fig. 1B-1 and fill the duct with grout of strength not less than 27 N/sq.mm. When the grout has attained the necessary strength, stress the tendon slowly increasing the load to the failure capacity. The failure capacity of the bond shall be at least equal to the anchorage efficiency or 0.95 of failure capacity of the tendon. At least 3 nos. of tests shall be carried out to ascertain the adequacy of the duct.

2. COMPRESSION TEST FOR THE LOSS OF WALL THICKNESS

Object: To establish the wear and tear of the sheathing material and the rigidity of the duct surface against indentation and abrasion under concentrated line loading from the tendon constituents.

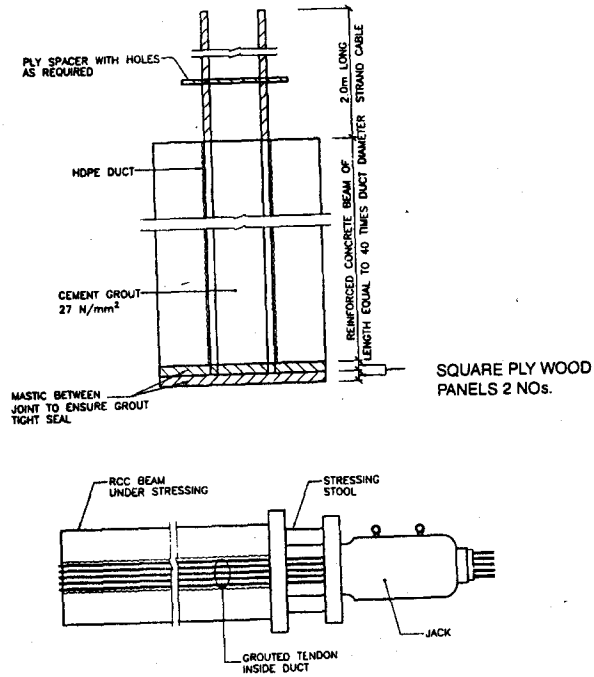
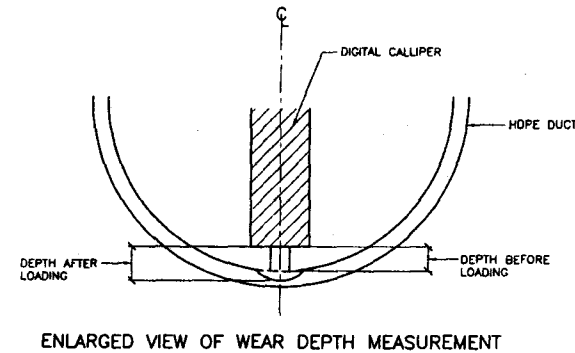
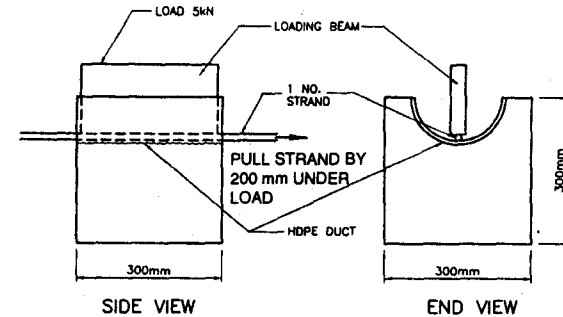

Fig. 1B-1. Bond test arrangement

Equipment:

- * 3 nos. of concrete blocks
- * 1 no. of 1000 mm long strand forming the tendon
- * A 3 MN press
- * A loading beam of 300 mm length to transmit 5 kN load
- * A rubber pad for placing between the press and the beam for uniform and constant load transfer
- * A bearing plate with a mono strand jack to pull the strand under loaded condition
- * A digital calliper

Method: Cast 3 nos. of concrete cubes of 300 mm size, of the same strength as of main structure, with half cut HDPE sheathing ducts embedded in it at the top as shown in Fig. 1B-2. Care shall be exercised to ensure that the duct surface has uniform contact with concrete all around. Place the concrete block over the press with a 1000 mm length of strand forming the tendon placed in the duct and apply the 5 kN uniform load gradually as shown. Pull the strand under the stressed condition by 200 mm across the duct. Repeat the test on all the 3 nos. of ducts so embedded. Measure the indentations formed in all the 3 nos. of ducts along the length of the strand, by means of digital calliper. The residual thickness of the duct shall not be less than 1.5 mm.



ENLARGED VIEW OF WEAR DEPTH MEASUREMENT

Fig. 1B-2. Compression test arrangement

Appendix-2

SPECIFICATION FOR SHEATHING DUCT JOINTS

The sheathing ducts shall be of the spiral corrugated type. For major projects, the sheathing ducts should preferably be manufactured at the project site utilising appropriate machines. With such an arrangement, long lengths of sheathing ducts may be used with consequent reduction in the number of joints and couplers.

Where sheathing duct joints are unavoidable, such joints shall be made cement slurry tight by the use of corrugated threaded sleeve couplers which can be tightly screwed on to the outer side of the sheathing ducts. A heat-shrink coupler could also be used if suitable.

Typical details of a sleeve coupler is shown in Fig. 2.1. The length of the coupler should not be less than 150 mm but should be increased upto 200 mm wherever practicable. The joints between the ends of the coupler and the duct shall be sealed with adhesive sealing tape to prevent penetration of cement slurry during concreting. The couplers of adjacent ducts should be staggered wherever practicable. As far as possible, couplers should not be located in curved zones. The corrugated sleeve couplers are being conveniently manufactured using the sheath making machine with the next higher size of die set.

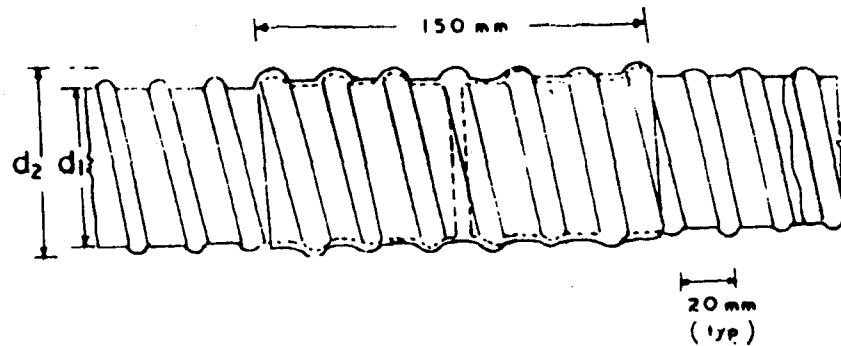

Fig. 2.1

The heat-shrink coupler Fig. 2.2 is supplied in the form of bandage rolls which can be used for all diameters of sheathing ducts. The bandage is

coated on the underside with a heat sensitive adhesive so that after heating the bandage material shrinks on to the sheathing duct and ensures formation of a leak proof joint, without the need for extra taping or support in the form of corrugated sleeve couplers. The heating is effected by means of a soft gas flame.

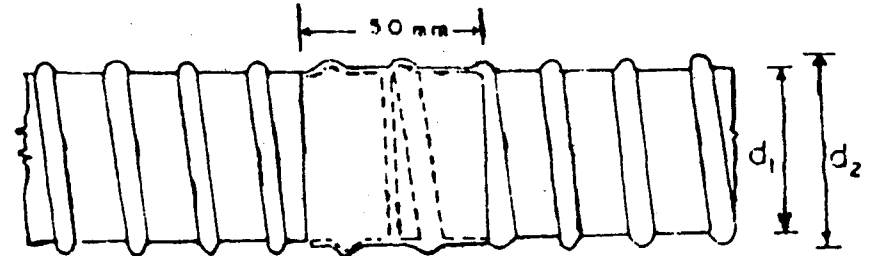

Fig. 2.2

*Appendix-3***RECOMMENDED PRACTICE FOR STORAGES AND HANDLING OF PRESTRESSING MATERIAL**

1. All prestressing steel, sheathing, anchorages and sleeves or couplings shall be protected during transportation, handling and storage. For wires upto 5 mm dia, coils of about 1.5 m dia, and for wires above 5 mm dia, coils of about 2 m dia without breaks and joints shall be obtained from the manufacturer.
2. Materials shall be stored in accordance with the provisions contained in relevant specifications. All efforts shall be made to store the materials in proper places so as to prevent their deterioration or intrusion by foreign matter and to ensure their satisfactory quality and fitness for the work. The storage space shall also permit easy inspection, removal and re-storage of the materials.
3. The prestressing steel, sheathing and other accessories shall be stored under cover and protected from rain or damp ground. These shall also be protected from the ambient atmosphere if it is likely to be aggressive. All prestressing steel shall be provided with temporary protection during storage such as coating of soluble oils, silica gel or vapour phase inhibiting materials of proven specifications.
4. Storage at site shall be kept to the absolute minimum. All materials even though stored in approved godowns shall be subjected to acceptance test prior to their immediate use.

*Appendix-4***RECOMMENDED PRACTICE FOR PRESTRESSING OPERATIONS**

Prestressing operation and grouting shall be entrusted to only specially trained and qualified personnel. All prestressing accessories shall be procured from authorised manufacturers with in-house testing facilities. Contractors shall also be required to engage specialised agencies who should also be entrusted with the total service contract for fabrication of cables, protection of cables during concreting, prestressing and grouting. Necessary certificates shall also be accorded by such specialised agencies that the work has been carried out in accordance with prescribed specifications. In exceptional cases where the client is convinced that the contractor of the bridge itself is well experienced and has qualified personnel and sufficient track record to substantiate his performance in the particular system of prestressing being adopted, the prestressing and grouting operations could be entrusted to the contractor.

RECOMMENDED PRACTICE FOR GROUTING OF POST-TENSIONED CABLES IN PRESTRESSED CONCRETE BRIDGES

1. GENERAL

- 1.1. The recommendations cover the cement grouting of post-tensioned tendons of prestressed concrete members of bridges. This also covers some of the essential protective measures to be adopted for minimising corrosion in PSC bridges.
- 1.2. The purpose of grouting is to provide permanent protection to the post-tensioned steel against corrosion and to develop bond between the prestressing steel and the surrounding structural concrete. The grout ensures encasement of steel in an alkaline environment for corrosion protection and by filling the duct space, it prevents water collection and freezing.

2. MATERIALS

2.1. Water

Only clean potable water free from impurities conforming to Clause 3.3 of this criteria shall be permitted. No sea or creek water is to be used at all.

2.2. Cement

Ordinary Portland Cement should be used for preparation of the grout. It should be as fresh as possible and free from any lumps. Pozzolana cement shall not be used.

2.3. Sand

It is not recommended to use sand for grouting of prestressing tendons. In case the internal diameter of the ducts exceed 150 mm, use of sand may be considered. Sand, if used, shall conform to IS: 383 and shall pass through IS Sieve No. 150. The weight of sand in the grout shall not be more than 10 per cent of the weight of cement, unless proper workability can be ensured by addition of suitable plasticizers.

2.4. Admixtures

Acceptable admixtures conforming to IS: 9103 may be used if tests have shown that their use improves the properties of grout, i.e. increasing fluidity, reducing bleeding, entraining air or expanding the grout. Admixtures must not contain chlorides, nitrates, sulphides, sulphites or any other products which are likely to damage the steel or grout. When an expanding agent is used, the total unrestrained expansion should not exceed 10 per cent. Aluminium powder as an expanding agent is not recommended for grouting because its long term effects are not free from doubt.

2.5. Sheathing

- 2.5.1. For specifications sheathing, Clause 3.6 of this criteria may be referred to.

2.5.2. Grout openings or vents

- (a) All ducts should have grout opening at both ends. For this purpose special openings should be provided where such openings are not available at end anchorages. For draped (curved) cables crown points should have a grout vent. For draped cables longer than 50 m grout vents or drain holes may be provided at or near the lowest points. It is a good practice to provide additional air vents at suitable intervals. All grout openings or vents should include provisions for preventing grout leakage.
- (b) Standard details of fixing couplers, inlets, outlets and air vents to the duct/anchorage shall be followed as recommended by the supplier of the system of prestressing.

- 2.5.3. Ducts should be securely fastened at close intervals. All unintended holes or openings in the duct must be repaired prior to concrete placing. The joints of the couplers and the sheathing should be made water proof by use of tape or similar suitable system capable of giving leak proof joints. Grout openings and vents must be securely anchored to the duct and to either the forms or to reinforcing steel to prevent displacement during concreting operations due to weight, buoyancy and vibrations.

- 2.5.4. Ducts require very careful handling as, being of thin metal, they are susceptible to leakage due to corrosion in transit or storage, by tearing ripping in handling particularly when placed adjoining to reinforcing steel, by pulling apart of joints while inserting tendons prior to concreting, or by accidental puncturing while drilling for form ties/inserts. Ducts are also liable to damage by rough use of internal vibrator and sparks from welding being done close by.

3. EQUIPMENT

3.1. Grout Colloidal Mixer

It is essential that the grout is maintained in a homogenous state and of uniform consistency so that there is no separation of cement during entire grouting process. It is, therefore, necessary that the grout be continuously mixed in a colloidal mixer with a minimum speed of 1000 RPM and travel of discharge not exceeding 15 m per second.

3.2. Grout Pump

The pump should be a positive displacement type and should be capable of injecting the grout in a continuous operation and not by way of pulses. The grout pump must be fitted with a pressure gauge to enable pressure of injection to be controlled. The minimum pressure at which grout should be pumped shall be 0.3 MPa and the grout pump must have a relief arrangement for bypass of the grout in case of build up of pressure beyond 1 MPa. The capacity of the grout pump should be such as to achieve a forward speed of grout of around 5 to 10 metres per minute. The slower rates are preferable as they reduce the possibility of occurrence of voids. If the capacity of the pump is large, it is usual to grout two or more cables simultaneously through a common manifold.

Use of hand pumps for grouting is not recommended. Use of compressed air operated equipment for injection is prohibited as it is likely that there will be some air entrapped in grout.

3.3. Water Pump

Before commencement of grouting, a stand by direct feed high pressure water pump should be available at site for an emergency.

In case of any problem in grouting the ducts, such pump shall immediately be connected to the duct and all grout flushed by use of high pressure water flushing. It is, therefore, necessary to have adequate storage of clean potable water for operation of the water pump for such emergencies.

3.4. Grout Screen

The grouting equipment should contain a screen having a mesh size of IS: 106 (IS:150 if sand is used). Prior to introduction into the grout pump, the grout should be passed through such screen. This screen should be easily accessible for inspection and cleaning.

3.5. Connections and Air Vents

Standard details of fixing inlets, outlets, and air vents to the sheathing and/or anchorage should be followed as recommended by specialist supplier of the system of prestressing. In general, all connections are to be of the "Quick couple" type and at change of diameters suitable reducers are to be provided.

4. PROPERTIES OF THE GROUT

- 4.1. Water/cement ratio should be as low as possible, consistent with workability. This ratio should not normally exceed 0.45.
- 4.2. The temperature of the grout after accounting for the ambient temperature of the structure shall not exceed 25°C.
- 4.3. Before grouting, the properties of the grout mix should be tested in a laboratory depending on the facilities available. Tests should be conducted for each job periodically. The recommended test is described below.
 - 4.3.1. Compressive strength: The compressive strength of 100 mm cubes of the grout shall not be less than 17 MPa at 7 days. Cubes shall be cured in a moist atmosphere for the first 24 hours and subsequently in water. These tests shall be conducted in advance to ascertain the suitability of the grout mix.

5. MIXING OF GROUT

- 5.1. Proportions of materials should be based on field trials made on the grout before commencement of grouting, but subject to the limits specified above. The materials should be measured by weight.
- 5.2. Water should be added to the mixer first, followed by portland cement and sand, if used. Admixture, if any, may be added as recommended by the manufacturer.
- 5.3. Mixing time depends upon the type of the mixer but will normally be between 2 and 3 minutes. However, mixing should be for such a duration as to obtain uniform and thoroughly blended grout, without excessive temperature increase or loss of expansive properties of the admixtures. The grout should be continuously agitated until it is injected.
- 5.4. Once mixed, no water shall be added to the grout to increase its fluidity.
- 5.5. Hand mixing is not permitted.

6. GROUTING OPERATIONS

6.1. General

- (a) Grouting shall be carried out as early as possible but not later than 2 weeks of stressing a tendon. Whenever this stipulation cannot be complied with for unavoidable reasons, adequate temporary protection of the steel against corrosion by methods or products which will not impair the ultimate adherence of the injected grout should be ensured till grouting. The sealing of the anchorage ends after concreting is considered to be a good practice to prevent ingress of water. For structures in aggressive environment, sealing of the anchorage ends is mandatory.

Notes : 1. Application of some patented water soluble oils for coating of steel/VPI powder injection/sending in of hot, dry, oil-free compressed air through the vents at frequent intervals have shown some good results.

2. Some of the methods recommended for sealing of anchorages are to seal the openings with bitumen

impregnated gunny bag or water proof paper or by building a brick pedestal plastered on all faces enclosing the exposed wires outside the anchorages.

- (b) Any traces of oil if applied to steel for preventing corrosion should be removed before grouting operation.
- (c) Ducts shall be flushed with water for cleaning as well as for wetting the surfaces of the duct walls. Water used for flushing should be of same quality as used for grouting. It may, however, contain about 1 per cent of slaked lime or quick lime. All water should be drained through the lowest drain pipe or by blowing compressed air through the duct.

- (d) The water in the duct should be blown out with oil free compressed air.

Blowing out water from duct for cables longer than 50 m draped up at both ends by compressed air is not effective, outlet/vent provided at or near the lowest point shall be used to drain out water from duct.

- (e) The connection between the nozzle of the injection pipe and duct should be such that air cannot be sucked in.
- (f) All outlet points including vent openings should be kept open prior to commencement of injection grout.
- (g) Before grouting, all air in the pump and hose should be expelled. The suction circuit of the pump should be air-tight.

6.2. Injection of grout

- (a) After mixing, the grout should be kept in continuous movement.
- (b) Injection of grout must be continuous and should not be interrupted.
- (c) For vertical cable or cables inclined more than 60° to the horizontal injection should be effected from the lowest anchorage or vent of the duct.
- (d) The method of injection should ensure complete filling of the ducts. To verify this, it is advisable to compare the volume of

the space to be filled by the injected grout with the quantity of grout actually injected.

- (e) Grouting should be commenced initially with a low pressure of injection of upto 0.3 MPa increasing it until the grout comes out at the other end. The grout should be allowed to flow freely from the other end until the consistency of the grout at this end is the same as that of the grout at the injection end. When the grout flows at the other end, it should be closed off and build up of pressure commenced. Full injection pressure at about 0.5 MPa shall be maintained for at least one minute before closing the injection pipe. It is a recommended practice to provide a stand pipe at the highest point of the tendon profile to hold all water displaced by sedimentation or bleeding. If there is a build up of pressure much in excess of 1 MPa without flow of grout coming at the other end, the grouting operation should be discontinued and the entire duct flushed with high pressure water. Also, the bypass system indicated in para 3.2 above is essential for further safety.
- (f) In the case of cables draped downwards e.g. in cantilever construction simultaneous injection from both ends may be adopted Fig. 5.1.
- (g) Grout not used within 30 minutes of mixing should be rejected.
- (h) Disconnection is facilitated if a short length of flexible tube connects the duct and injection pipe. This can be squeezed and cut off after the grout has hardened.

7. PRECAUTIONS AND RECOMMENDATIONS FOR EFFECTIVE GROUTING

- (a) In cold and frosty weather, injection should be postponed unless special precautions are taken. If frost is likely to occur within 48 hours after injection, heat must be applied to the member and maintained for at least 48 hours after injection so that the temperature of the grout does not fall below 5°C. Prior to commencement of grout, care must be taken to ensure that the duct is completely free of frost/ice by flushing with warm water, but not with steam.

- (b) When the ambient temperature during the day is likely to exceed 40°C, grouting should be done in the early morning or late evening hours.
- (c) When the cables are threaded after concreting, the duct must be temporarily protected during concreting by inserting a stiff rod or a rigid PVC pipe or any other suitable method.
- (d) During concreting, care shall be taken to ensure that the sheathing is not damaged. Needle vibrators shall be used with extreme care by well experienced staff only, to ensure the above requirements.
- (e) It is a good practice to move the cables in both directions during the concreting operations. This can easily be done by light hammering the ends of the wires/strands during concreting. It is also advisable that 3 to 4 hours after concreting the cable should be moved both ways through a distance of about 20 cms. With such movement, any leakage of mortar which has taken place in spite of all precautions, loses bond with the cables, thus reducing the chance of blockages. This operation can also be done by fixing prestressing jacks at one end pulling the entire cable and then repeating the operation by fixing the jack at the other end.
- (f) The cables to be grouted should be separated by as much distance as possible.
- (g) In case of stage prestressing, cables tensioned in the first stage should not remain ungrouted till all cables are stressed. It is a good practice, while grouting any duct in stage prestressing, to keep all the remaining ducts filled up with water containing 1 per cent lime or by running water through such ducts till the grout has set. After grouting the particular cable, the water in the other cables should be drained and removed with compressed air to prevent corrosion.
- (h) Care should be taken to avoid leaks from one duct to another at joints of precast members.
- (i) End faces where anchorages are located are vulnerable points of entry of water. They have to be necessarily protected with an

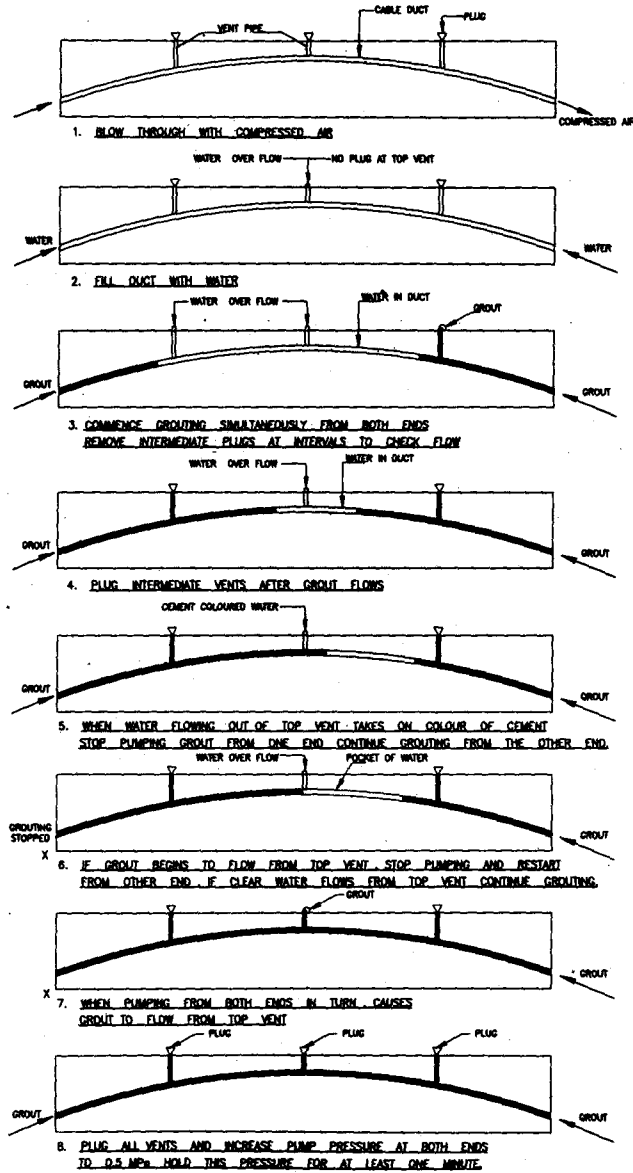

Fig. 5.1. Procedure for grouting of cables draped downwards

effective barrier. Recesses should be packed with mortar concrete and should preferably be painted with water proof paint.

- (j) After grouting is completed, the projecting portion of the vents should be cut off and the face protected to prevent corrosion.