

AUTOMOTIVE INDUSTRY STANDARD

**Constructional and Functional
Requirements for Road Ambulances**

*PRINTED BY
THE AUTOMOTIVE RESEARCH ASSOCIATION OF INDIA
P.B. NO. 832, PUNE 411 004*

*ON BEHALF OF
AUTOMOTIVE INDUSTRY STANDARDS COMMITTEE
UNDER
CENTRAL MOTOR VEHICLE RULES – TECHNICAL STANDING COMMITTEE*

*SET-UP BY
MINISTRY OF ROAD TRANSPORT and HIGHWAYS
(DEPARTMENT OF ROAD TRANSPORT and HIGHWAYS)
GOVERNMENT OF INDIA*

August 2014

Status chart of the standard to be used by the purchaser for updating the record

Sr. No.	Corrigenda	Amendment	Revision	Remark	Date	Misc.

General Remarks:

INTRODUCTION

The Ministry of Road Transport and Highways, Govt. of India set up five Working Groups on 4Es of Road Safety i.e. Education, Engineering (Vehicles), Enforcement and Emergency Care on the recommendation of the National Road Safety Council (NRSC). The Working Group on Emergency Care in its report observed that the real concept of an ambulance is missing in India. Existing ambulances are more like transport vehicles and any vehicle suitable to lay a patient is called an ambulance without consideration to the overall ambulance design. Research has shown that ambulances are more likely to be involved in motor vehicle collisions resulting in injury or death than either fire trucks or police cars. Unrestrained occupants, particularly those riding in the patient-care compartment, are particularly vulnerable. It is, therefore, all the more necessary in an ambulance to take care of occupant safety, patient care ergonomics, medical equipment selection and placement, vehicle engineering and integration, etc.

The working group recommended that there is a need to formulate the “**National Ambulance Code**” with necessary amendments in Central Motor Vehicle Rules (CMVR) that defines the Constructional and Functional Requirements for Road Ambulances. In view of this, an Expert Committee comprising the members (Refer Annexure 3) was constituted with approval of the Hon’ble Union Minister for Road Transport and Highways to formulate the “National Ambulance Code”:

The **terms of reference** of the Committee were as under: “The Committee will formulate ‘National Ambulance Code’ along with detailed specifications for various types of ambulances for the country and prepare a draft amendment notification to CMVR 1989.”

The committee referred the following global best practices / research in this domain:

- a) Ambulance Manufacturers Division (AMD) of the National Truck Equipment Association (NTEA), USA.
- b) NHS, UK: Future Ambulances
- c) ACS, ACEP - USA: Equipments for Ambulances
- d) Gupta SK, Singh AR, Patnaik SK (December 2010). Specifications of Advanced Life Support Ambulances. Department of Hospital Administration, AIIMS, New Delhi
- e) Lechleuthner A, Marten D, Anschütz B, (February 2012).Electrical Systems in Ambulances. Institute of Rescue Engineering, University of Applied Sciences, Cologne, Germany

- f) Lechleuthner A, Marten D, Lohölter M, (February 2012).Emergency Vehicles in India - Standardization of Recognition and Perception. Institute of Rescue Engineering, University of Applied Sciences, Cologne, Germany

The Committee took stock of the existing trends vis-a-vis ambulance construction, design and integration to understand the current scenario, limitations of the existing framework, available technology, manufacturer maturity, local conditions, past trends, etc. Some of the photographs of ambulances being operated in countries abroad namely USA, UK, Europe, Dubai, Hong Kong, Malaysia, South Africa, Israel and Thailand are given below for reference.

The committee members shared their experiences as regards the Indian reality and deliberated on the reasons behind the pathetic condition of ambulances as on date. The following important points were highlighted during these discussions:

- There is no standardization of ambulance design across various procurements in the country and the industry is forced to re-integrate their vehicles every now and then.
- Most of the ambulance specifications are written by medical specialists who are unable to translate the user requirements in automobile terminology thereby resulting in a huge gap between the user expectations and industry deliverability.
- There are certain inherent limitations in the existing laws which allow goods vehicles to be converted as ambulances for passenger application without incorporating essential safety features in patient compartment like side door, forward backward seating, occupant restraints, certified electrical systems, etc.

The committee initially drafted the standard in line with the global best practices referred above and localized the same to suit Indian requirements. The document was then circulated to SIAM

During the deliberations of the committee the vehicle manufacturers (OEM's) agreed to issue necessary instructions to the buyer of the incompletely built vehicle about the constructional and functional aspects of the ambulance. Any body builder who is engaged in the activity of building ambulances need to follow the prescriptions of this code for necessary compliance, verification or certification.

The Automotive Industry Standards Committee (AISC) responsible for preparation of this standard is give in Annexure 4

Para. No.	Contents	Page No.
1.	Scope	1/56
2	References	1/56
3	Terms and Definitions	6/56
4	Vehicle Characteristics	7/56
5	Testing of Maintain Systems and Fixations of the Equipment in the Patient's Compartment	17/56
6	Medical Devices	18/56
Annexure-1	Recognition	34/56
Annexure-2	Technical Information to be Submitted by the Road Ambulance Manufacturer	40/56
Annexure 3	Composition of AISC Panel	55/56
Annexure 4	Automotive Industry Standards Committee composition	56/56

1.0 SCOPE

This standard specifies the constructional and functional requirements of Category M and L vehicles used for transport and / or emergent care of patients (Road Ambulance).

- a) This code does not detail the requirements of training of the staff in the ambulance which will be the responsibility of the user in whose name the ambulance will be registered or the operator as the case maybe.
- b) This code doesn't cover Mobile Health Units and other such specialized mobile medical facilities which will not be used to transport patients in supine state but will only provide preventive, emergent or elective medical care / diagnostic facilities inside the vehicle to the patients when stationary.
- c) This Code shall not be mandatory to Ambulances manufactured for Armed Forces, para-military forces and police forces. However, these agencies may opt for procuring Ambulances complying to this Code if so desired by them.

Note : For the purposes of categorization of the Ambulance as M1, M2 or M3, a stretcher may be considered equivalent to four seating positions, based on the request of the Ambulance manufacturer.

2.0	REFERENCES	
2.1	CMV(A)R,1989	Central Motor Vehicles (Amendment) Rules, 1989 as amended form time to time.
2.2	AIS-004(Part 1)-1999	Electromagnetic radiation from automotive vehicle – Permissible levels and methods of tests
2.4	AIS-004(Part 3)-2009	Automotive vehicles - Requirements for electromagnetic compatibility
2.5	AIS-020-2004	Automotive vehicles - Interior noise - Method of measurement and requirements
2.6	AIS-053-2005	Automotive vehicles-Types-Terminology

3.0 TERMS AND DEFINITIONS

For the purposes of this standard, the following terms and definitions apply:

3.1 Road Ambulance

Road Ambulance or Ambulance is a specially equipped and

ergonomically designed vehicle for transportation / emergent treatment of sick or injured people and capable of providing out of hospital medical care during transit / when stationary, commensurate with its designated level of care when appropriately staffed.

3.2 Patient

Any sick or injured person whose condition requires appropriately trained personnel to provide medical care and / or suitable transport.

3.2.1 Emergency Patient

Patient who through sickness, injury or other circumstances is in immediate or imminent danger to life unless emergency treatment and / or monitoring and suitable transport to appropriate medical facilities or medical treatment are provided.

3.3 Types of Road Ambulances

Road Ambulances are designated as follows based on the level of care they can provide

3.3.1 Type A Road Ambulance /Medical First Responder

Road Ambulance designed to provide emergent out of hospital medical care to patients when stationary. This vehicle maybe any CMVR approved Category M or L vehicle suitable for the terrain to be used in but will not have the capability to transport patients in supine state or provide them medical care inside the vehicle.

3.3.2 Type B Road Ambulance/ Patient Transport Vehicle

Road ambulance designed and equipped for the transport patients who are not expected to become emergency patients.

3.3.3 Type C Road Ambulance: Basic Life Support Ambulance

A vehicle ergonomically designed, suitably equipped and appropriately staffed for the transport and treatment of patients requiring non-invasive airway management / basic monitoring.

3.3.4 Type D Road Ambulance: Advanced Life Support Ambulance

A vehicle ergonomically designed, suitably equipped and appropriately staffed for the transport and treatment of emergency patients requiring invasive airway management / intensive monitoring.

3.4 Un-laden Vehicle Weight

The un-laden vehicle weight of the road ambulance shall be that specified by the vehicle manufacturer or the road ambulance builder in accordance with IS 9211: 2003 or as per CMV (A) R, 1989.

Note: Loose portable patient handling, sanitary, medical and technical equipment are not included in un laden vehicle weight.

3.5 Permissible Gross Vehicle Weight

The permissible gross vehicle weight of the road ambulance shall be that specified by the vehicle manufacturer or the road ambulance builder in accordance with IS 9211: 2003 or as per CMV (A) R, 1989.

The Permissible Gross Vehicle Weight shall take into consideration the unladen vehicle weight as per 3.4 above and also the mass of sanitary, medical and technical equipment, the mass of passengers, taken as 75 kg per person, and any reserve mass.

3.6 Loading Capacity / Pay Load

The difference between the gross vehicle weight and the unladen vehicle weight is the loading capacity or the pay load.

3.7 Fixation System

System or device to ensure the permanent fixation of medical devices or other equipment into the ambulance.

3.8 Maintain System

Bracket / interfaces / holders or any other types of systems / devices used to secure a mobile or transportable item of equipment or medical device of the vehicle without the use of tools.

4.0 VEHICLE CHARACTERISTICS

4.1 General Construction

The road ambulance shall comply with homologation requirements given in standards notified under CMVR 1989 and this Code. Wherever, there is difference in the homologation requirements given in other standards notified under CMVR 1989 and this code, the requirements of this code will be applicable. Technical information to be submitted by the Road Ambulance Manufacturer shall be as per Annexure 2

4.2 Performance Requirements

4.2.1 Acceleration

A road ambulance loaded to the permissible gross vehicle weight shall be able to accelerate from 0 km/h to 70 km/h within 40s, when tested in accordance with IS: 11851-1986.

4.3 Electrical Requirements

4.3.1 General

Electrical installations shall comply with those clauses of IEC 60364-7-708 which are applicable to ambulances.

Note 1: The reference to IEC 60364-7-708 does not apply to the original electrical equipment, which is already covered by the type approval of the base vehicle.

4.3.2 Battery and alternator

Batteries shall be positioned to allow maintenance without removing the battery from its securing device. The construction of the battery and all connections to it shall be such as to prevent any possibility of an inadvertent short circuit.

Note 1: Additional batteries may be required to power the medical devices carried on board and the intended use of the ambulance. In such cases, the manufacturer shall ensure optimal charging of the additional batteries without any impact on the primary vehicle battery. The additional circuit shall not draw current more that specified by the manufacturer. However If a Genset is provided, requirements of additional batteries shall not be applicable. Additionally Table 1 will be applicable only if additional battery(ies) are provided.

Table 1

Indicative Capacity / Power (These values are given as a broad guideline only. The manufacturers may alter them based on vehicle characteristics and operational requirements.)

		Type of Ambulance	
		C	D
Additional Battery(ies) (if deployed)	Nominal Voltage 12V	80Ah	80Ah
	Nominal Voltage 24V	63Ah (2x12V)	63Ah (2x12V)
Alternator Power		700W	1200W

Note 2: When the engine is idling, electrical stability should be maintained between electrical load and alternator output. In order to achieve this it may be necessary to fit an electrical load prioritisation device to the vehicle.

Manufacturer shall give declaration regarding the certified capacity of the electric system of the vehicle model in the following format:

Sr. No.	Ambulance Type	Additional Electric Load of Medical Equipment's permissible (Watts)
1	A/B/C/D	XXX

This shall be prominently displayed in the patient compartment at an appropriate location. Further each electrical socket provided in the patient compartment should be permanently labelled as regards its voltage and amperage.

4.3.3 **Electrical installation**

4.3.3.1 In Type C and D road ambulances, there shall be a recessed externally mounted power connector to enable external power to be provided for operations such as the following:

- a) Charging battery (ies) for medical equipment.
- b) Operating medical devices, when installed.
- c) Operating a stand-alone patient compartment heater, when installed.
- d) Operating an engine pre-heater, when installed.

The connector for 220/240 V, shall be a male/female connector and not interfere with the electrical and mechanical safety.

It shall be not possible to start the engine whilst it is connected to an external 220/240 V power supply unless an automatic mechanical disconnection is fitted. If no automatic mechanical disconnection is fitted, the connector shall be on the driver's side. This requirement shall not be applicable if the Engine of the vehicle is used for operating Air Conditioning system of the vehicle when external power supply is connected.

The 220/240 V circuit shall be protected either by an "earth leakage device" with a maximum setting of 30 mA or by a separate transformer. If the protection is given only by an "earth leakage device" there shall be a label near the plug that reads as follows: "CAUTION! CONNECT ONLY TO AN AUTHORISED SOCKET."

4.3.3.2 The patient's compartment shall be fitted with the minimum number of connections as given in Table 2. For these connections a permanent power supply shall exist.

Table 2
12V connections for medical devices in patient's compartment

	Type of Road Ambulance	
	C	D
Minimum number of connections	2	4

4.3.3.3 Any additional electrical systems fitted to the base vehicle shall be separate from the base vehicle electrical system and the body or chassis shall not be used as an earth return for additional circuits. All circuits in the additional system(s) shall have separate overload protection. Overload protection may consist of either fuses or so called Electronic Management Control systems. All circuits shall be well defined and cables clearly marked at the connection points and at a maximum of 1m intervals along its length. Alternatively, cables in the circuits can be identified by following suitable color codes.

The system shall have enough circuits and be so constructed that when/if a circuit fails all illumination and medical technical equipment can be switched to an alternative power source.

4.3.3.4 The wiring and, where applicable conduits, shall withstand vibrations. No wiring shall be located in or pass through conduit intended for medical gas installation. The wiring shall not be loaded higher than that stated by the wire manufacture.

4.3.3.5 Where there are different voltage systems, the connections shall be non-interchangeable.

4.4 Vehicle Body

4.4.1 Fire safety

All interior materials shall comply with the flammability requirements specified in IS: 15061, as notified under CMV (A) R, 1989 though the standard does not cover ambulance in the scope.

4.4.2 Fitment of fire extinguisher

The ambulance of Type C and D shall be equipped with Two fire extinguishers of 2 Kg each.

4.4.3 Minimum loading capacity

The minimum loading capacity shall be in accordance with Table 3.

Table 3
Minimum Loading Capacity (Persons)

	Type of Road Ambulance			
	A	B	C	D
Number of seats and / or stretcher facilities (in addition to driver seat)	-	2	3	4

4.4.4 Partition wall

In type C and D road ambulances, a full partition wall or a partition wall with a door or a window shall separate the driver's compartment from the patient's compartment. Where a door is fitted, it shall be secured against opening if the road ambulance is in motion.

One or two windows with a minimum separation of 100 mm shall be provided in the partition wall made of material complying with the requirements of CMVR. The windows shall allow direct visual contact with the driver. The opening area of the window shall have a maximum area of 0.12 m². It shall be secured against self-opening and shall have an adjustable blind or other means of preventing the driver being disturbed by the light of the patient's compartment.

4.4.5 Openings (Doors, Windows, Emergency Exits)

4.4.5.1 General

The driver seat shall comply with the requirements of AIS-023:2005 or IS:15546-2005 as applicable and notified under CMVR. There shall be a minimum of two openings – one at the rear (door/tailgate) and one at the side (door/window) of the patient's compartment. All openings shall have seals to protect against the ingress of water and dust.

All openings shall comply with the minimum dimensions set out in Table 4.

Table 4

Minimum opening dimensions in the patient compartment

		Type of Road Ambulance			
		A ^a mm	B ^a mm	C mm	D mm
Side Opening	Height ^c	b	b	1200	1300
	Width ^c	b	b	660	660
Rear Opening	Height	-	900	1100	1300
	Width	-	900	1050	1050
<p>a. Corner radius of conversions which reduce the opening area by less than 10 % are permitted. If the vehicle characteristics so require, a reduction up to 10% in the opening sizes is permissible.</p> <p>b. The dimensions provided by the original manufacturer shall not be reduced.</p> <p>c. If it is a window, the minimum height and width dimensions shall be 450 mm and 550mm respectively for Type C and D ambulances. If window/s are provided in addition to side door and side door complies with side opening dimensions (if applicable), then dimensional requirement for these windows shall be considered as exempted.</p>					

4.4.5.2 Doors

For Type C and Type D road ambulance, each external door of the patient's compartment shall be fitted with a security system which enables the following:

- a) lock and unlock from inside without use of a key
- b) lock and unlock from outside with use of a key
- c) Unlock from the outside using a key when the door is locked from the inside.

Note: This security system may be integrated with an optional central locking system. The patient's compartment doors shall be capable of being positively restrained in the open position. An audible or visual signal shall warn the driver when any door is not completely closed when the vehicle is in motion. The key can be a mechanical or non-mechanical device.

4.4.5.3 Windows

In the patient's compartment, there shall be a minimum of two external windows. There shall be one on each side or one on the side and other at the rear. The windows shall be positioned or screened to ensure patient's privacy when required. Windows shall be fitted with safety glasses complying with the requirements of IS:2553 specified under Rule 100 of CMV(A)R, 1989. The field of vision requirements as per AIS 002 shall not be applicable for interior rear view mirrors for all type of ambulances.

4.4.6 **Stretcher loading**

In type C and D ambulances, the loading area requirements shall be in accordance with Table 5.

Table 5
Loading Specifications

		Type of Road Ambulance	
		C	D
Loading Angle (Stretcher)	Maximum	16 ^{o a}	16 ^{o a}
Loading Height (Stretcher)	When the patient is manually loaded or unloaded on the stretcher, the centre of the stretcher handles shall be no more than 825 mm above ground level. The maximum height of either the floor or the loading holding assembly above ground level shall not exceed 750 mm at net vehicle mass plus loose equipment.		
a. The loading angle shall be kept as low as possible.			

Where a ramp or lift is installed between ground level and vehicle floor level it shall be covered with a anti-slip surface and capable of taking a constant load of 350 kg. In the event of a power failure the loading device shall be capable of being operated manually.

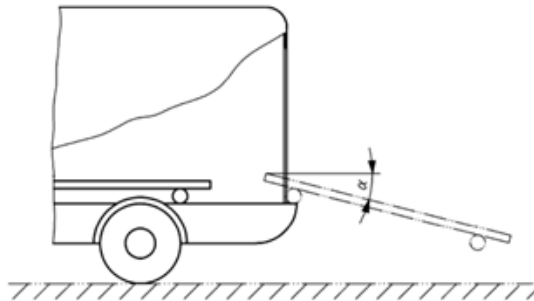

Figure -1
Loading angle for the stretcher

4.5 Patient's Compartment (Not Applicable to Type A Ambulances)

4.5.1 General

The patient's compartment in Type C and Type D Road Ambulances shall be designed and constructed to accommodate the medical devices. The width of the patient compartment for Type C and Type D Road Ambulance, after installation of cabinets, etc. shall provide 40 ± 15 cm clear aisle walkway between the main stretcher / undercarriage and the base of squad bench / attendant seats, with the main stretcher located in the street side (non-centred) position.

In Type D Ambulances, the length of the Patient Compartment shall provide at least 64 cm and not more than 76 cm of unobstructed space at the head of the primary patient, when measured from the face of the backrest of the Doctor's/Paramedic's Seat to the forward edge of the stretcher.

In Type C and D Ambulances, a minimum of 25 cm shall be provided from the end of the stretcher to rear loading door, to permit clearance for any traction or long-board splints.

The ceiling, the interior side walls and the doors of the patient's compartment in Type C and D Ambulances shall be lined with a material that is non-permeable and resistant to disinfectant. The edges of surfaces shall be designed and/or sealed in such a way that no fluid can infiltrate. If the floor arrangement does not allow fluids to flow away / mop / clean, one or more drain with plugs shall be provided.

For Type B Ambulances, in the area behind driver seat, the material of floor and side shall be non-permeable and resistant to disinfectant.

The Ambulances of Type B, C and D shall meet the interior fittings radius of curvature requirements as per IS 15223 for M1 and AIS-047 for M2 as amended from time to time. Medical equipment and their holding devices (for example stretchers, platforms, suction units etc.) are excluded. Drawers should be secured against self-opening and where lockers are fitted with doors that open upwards they should be fitted with a positive hold open mechanism.

Type C and D road ambulances shall be equipped with a lockable drugs compartment with security lock. Floor coverings shall be chosen that will provide adequate grip for the attendant including when wet and should be durable and easy to clean.

Type C and D road ambulances shall be fitted with a hand-holding device positioned above the stretcher. For type D the hand-holding device shall be positioned along the longitudinal axis. If the patient's compartment is to be equipped with a non-foldable chair, space shall be provided with a width of at least 600 mm measured at elbow height and a ceiling height above the

seat squab of at least 920 mm. Vehicle maintenance equipment (e.g. Spare wheel and Tools) shall be placed such that accessing them does not cause inconvenience to the patient.

~~Type C and D ambulances shall be provided with a wash basin in the patient compartment.~~

4.5.2 Patient and attendant seating

The minimum number of patient and attendant seats shall be as given in Table 6

Table 6
Number of Patient and Attendant Seats

		Type of Road Ambulance		
		B	C	D
Minimum number		1	2	2
Position (s)	on one side of the stretcher	1	1	-
	on one side of the stretcher upper 2/3 end	-	1	1
Position(s) at head of stretcher		-	-	1

4.5.3 Patient and attendant seat dimensions

Patient and attendant seat dimensions shall be minimum of 381 mm X 381 mm per seat. Seats fitted in the patient compartment shall be installed in either forward / sideward / rear-facing positions and shall be fitted with Two Point (Lap Belt) or Three Point Retractable Safety Belts (preferred for forward / rearward facing seats) in conformance with IS:15140-2003. Further, the anchorages of seat belts provided on the forward facing permanent seats shall meet the requirements of IS:15139-2003. Head restraints shall be fitted as applicable and in accordance with AIS-023:2005 or IS: 15546-2005. Backrests shall be constructed to a minimum dimension of 300 mm × 100 mm.

Note : The requirements of IS:15139 shall not be applicable to anchorages of seat belts fitted on rear / side facing and folding seats.

4.5.4 Patient compartment environmental equipment

The patient compartment shall be heated, ventilated, and air conditioned as required in accordance with the criteria specified hereto.

4.5.4.1 Air conditioning criteria

shall be optional in all categories of Road Ambulances except Type D Ambulances.

Air Conditioning

In Type D Road Ambulances, the cooling system should be such that, given an outside and inside temperature of 32°C, the cooling down to at most 27°C in the patient's compartment should not take longer than 15 min. After 30 min a temperature of at most 25 °C should be reached.

The inside temperature should be measured in the centre of the patient compartment and at the mid-point from the cooling outlets (if several outlets are available). The installation of the system shall not encourage exhaust gases entering the patient's compartment.

4.5.4.2 Heating

Heating system shall not be mandatory and would subject to specific requirement of the user. In the case of Type D Road Ambulances, if the heating system is provided, it shall meet the following specifications :

This system shall be such that given an outside and inside temperature of -10°C, the heating up to at least +15°C shall not take longer than 45 min. The inside temperature shall be measured in the centre of the patient compartment and at the midpoint from the heater outlets (if several outlets are available). The installation of the system shall not encourage exhaust gases entering the patient's compartment.

4.5.5 Interior lighting

Natural colour balance lighting shall be provided as set out in Table 8.

Note: The colour temperature of the light will change the appearance of skin and organs. Therefore it is important that the interior lighting is suitable for patient care during transport. Although it may not be necessary in ambulance use to define "daylight" or "natural colour balance" in a more exact way other than the colour temperature. The colour temperature of the interior lights should be minimum 4000 Degrees Kelvin.

In type D Ambulance, there shall be an additional light within the treatment area with a minimum of 1650 Lux. It shall be measured at the stretcher surface in its lowest position. The minimum distance of the measurement shall be 750 mm below the light and in an area with a minimum diameter of 200 mm.

Table 8

Patient's Compartment Illumination

			Type of Road Ambulance		
			B Lux	C Lux	D Lux
Patient Area (Stretcher)	Minimum	50	150	150	
Surrounding Area	Minimum	30	50	50	

Light levels shall be measured along the central longitudinal axis of the stretcher at the head, mid-point and foot position with the stretcher in its normal position for transportation in the ambulance.

4.5.6 Interior noise level

The interior noise level in the patient compartment in Type B, C and D Ambulances shall comply with requirements of AIS-020. During the test, the Siren of the Ambulance shall be kept in the Off position

4.5.7 Ingress of dust and rain water

In case of type B, C and D ambulances, all doors, windows and hatches shall not allow ingress of dust and rain water when in the fully closed position, when tested in accordance to IS : 11739 – 1986 as amended from time to time, for recording dust ingress in automotive vehicles, and when tested in accordance to IS: 11865 – 2006 as amended from time to time, for water proofing test for automobiles.

4.5.8 Mounting systems

The Seats, their anchorages and head restraints shall meet requirements of CMV Rule 125, as applicable.

The Stretcher along with undercarriage (without dummy) shall be subjected to dynamic test as per para 5.0. After being subjected to this dynamic test

- a) No failure shall occur in the stretcher frame or in the anchorage of stretcher. Permanent deformation including ruptures may be accepted, provided that they do not increase the risk of injury in the event of collision.
- b) No release of locking system shall occur during the test described in 5.0
- c) no items shall have sharp edges or endanger the safety of persons in the road ambulance

All lockers, rails and non-dedicated storage locations or storage devices shall be labelled to show the total maximum permissible weight allowed.

4.5.9 Main Stretcher

4.5.9.1 General

Ambulances of B, C and D category shall be provided with a main stretcher consisting of an integrated or separable undercarriage.

It shall be designed to provide that full weight of the patient and the carried stretcher part will only be lifted / carried by the personnel for the minimum period of time.

It shall be so designed to provide that during loading and unloading the maximum burden on any personnel is half of the total weight of patient and stretcher and for the minimum possible time and in optimal ergonomic position so that back bending is minimized.

The lying area shall have adjustable head-end / backrest with a minimum length of 550 mm. It shall be possible to turn up the head-end / backrest at least up to 75 degrees and there shall be at least five fixing positions within this range.

The lying area shall have an adjustable foot-end with a minimum length of 850 mm. It shall be possible to turn up the foot-end at least up to 15 degrees.

4.5.9.2 Main stretcher Dimensions

Dimensions shall be measured from the outer edges.

Length: Min 1800mm
Width: Min 480mm

Height: Maximum 380mm from the loading holding assembly to unladed lying part. The height dimension does not apply to stretchers with Monoblock undercarriages. If a monoblock is not available, the stretcher must be constructed so that it is detachable from the undercarriage.

4.5.9.3 Loading Capacity

The Loading capacity shall be a minimum of 150 Kg.

4.5.9.4 Undercarriage:

- a) The undercarriage shall be fitted with 4 wheels with a diameter of at least 100mm. There shall be a minimum of two 360 degree swivel wheels at the foot end and at least two wheels shall be fitted with a footbrake.
- b) The undercarriage shall have a simple mechanism for height adjustment and shall have a minimum of two levels (car position and fully unfolded)
- c) The supporting mechanism shall automatically stay in place when fully unfolded.
- d) If the undercarriage is used with a separable stretcher it shall be possible both to connect the undercarriage to the stretcher and to separate them easily. The mounting for the stretcher shall be secured in such a manner that unintentional separation of undercarriage and stretcher cannot occur. It shall be possible to load and unload the undercarriage and stretcher so as to ensure the safety and comfort of the patient and the operator.
- e) All the functions of the stretcher shall remain completely unimpaired when it is connected to the undercarriage.

4.5.9.5 Restraint system

The stretcher shall have a minimum of two quick-release patient restraints.

5.0 TESTING OF STRETCHER

Verification of conformity to fixation and maintain systems as detailed in 4.5.8 shall be made when the stretcher(s) and holding assembly is placed in the mean position of all possible positions available.

The sample submitted for test, shall be identical to or have the same characteristics and behaviour during test as would the production item or vehicle.

Note: Care should be taken that no internal / external additional reinforcement through the rig will modify the behaviour during test.

The head end of the stretcher shall be fixed in a position of 15° measured from the horizontal. The lying area of the stretcher tray assembly (holding assembly) shall be in a horizontal position.

The stretcher shall be fixed on the stretcher's holding assembly. The sedan chair (when provided) shall also be fixed in its holder.

The dynamic test shall be carried out using a patient's compartment assembly or a relevant part of the construction or an appropriate fixture mutually agreed between the test agency and manufacturer.

specified below :

- (a) In the longitudinal (forward and backward) directions (one after another) for Type B and Type C Ambulances.
- (b) In the longitudinal, transverse and vertical directions (one after another) for Type D Ambulances.

A deceleration of not less than 10g shall be applied for 30 milliseconds in the directions mentioned above. At the request of manufacturer, the test pulse given in Figure- 2 may be used alternatively. No failure shall occur in the stretcher frame or in the anchorage or locking devices during or after the dynamic test. Permanent deformation, including ruptures, may be accepted, provided that these do not increase the risk of injury in the event of collision and the prescribed loads were sustained. No release of the locking systems shall occur during the test.

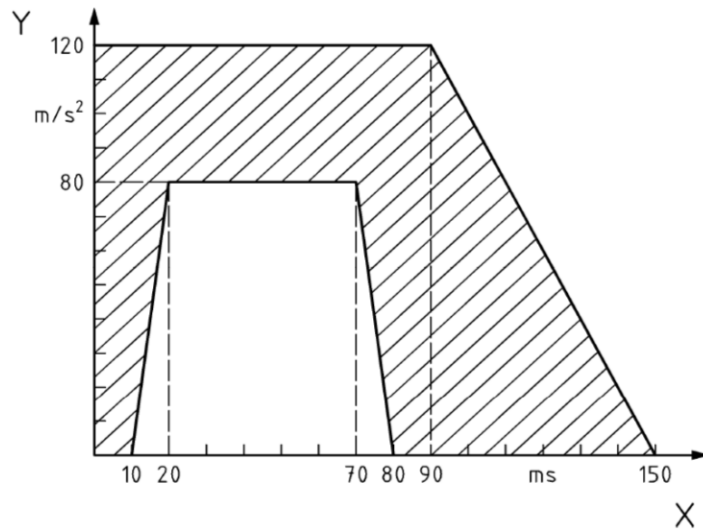

Figure 2
Acceleration impulse

6.0 Provision of Medical Devices

- 6.1 The road ambulance shall be designed and constructed to provide the following provision in order to ensure levels of care expected from each type of ambulances
- 6.2 The following provisions for basic treatment for first aid and nursing care shall be made available in Type B, C and D of ambulances
- a) Mounting for portable Oxygen cylinder of 2.2 L water capacity.
 - b) Hook for infusion mounting.
 - c) Storage for keeping first aid and nursing kit - Vehicle manufacturer shall include details of storage space for the same in the owner's manual.

ANNEXURE-1

(Para 6.3.9)

RECOGNITION

Recognition and visibility of ambulances

The Ambulance Conspicuity requirements is split into five sections.

- (i) Colour
- (ii) Conspicuity Improving Items
- (iii) Emblems
- (iv) Warning Lights
- (v) Sirens

The section “colour” describes the vehicles basic colour. The section “Conspicuity Improving Items” or “C2I” includes all Symbols, Marking and Striping defined as such by this standard. The section “Emblems” refers to every item that doesn’t fall under the definition of C2I which can be private company signs or corporate identities. The section “Warning Lights” describes colour, position, alignment, luminosity, photometric brightness, flash patterns and electrical current consumption of all used warning lights. The section “Sirens” determines the volumes, frequencies and electrical current consumption of all used sirens and speakers.

The installations by the following text shall closely correspond to the exterior design pictures below.

TYPE C
Ambulance

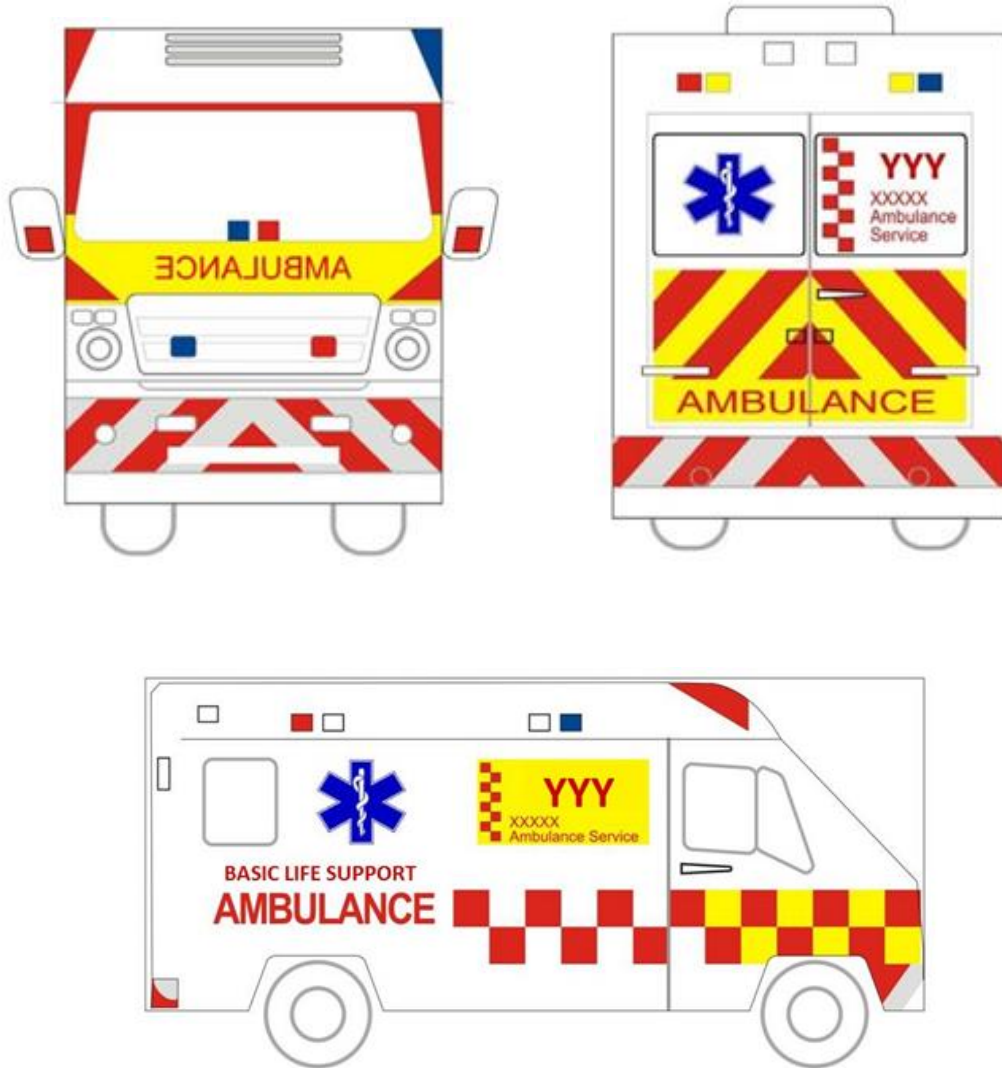

TYPE D Ambulance

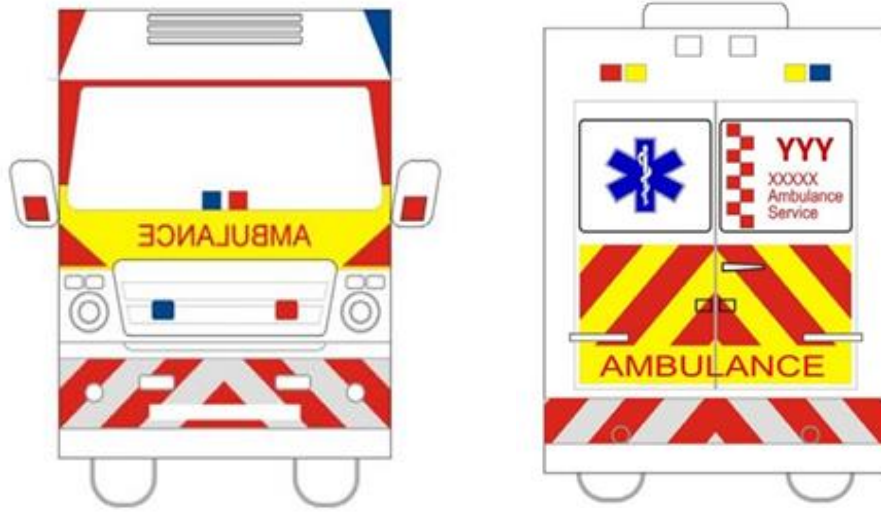

(i) Colour

The basic colour of the complete exterior should be brilliant white, RAL-Code 9010, excluding front, rear and side bumpers. The colour should be weather resistant and withstand daily cleaning and washing.

(ii) Conspicuity improving items

This definition includes all marking, striping and symbols as shown in the figure above. Conspicuity Improving Items defined by this standard are: chevron patterns in red/silver and red/yellow, Battenburg patterns, "AMBULANCE" markings, the Star of Life and the emergency number symbol. All "AMBULANCE" markings must follow a 7:1 ratio, length to height.

Front:

A. For Type C and D Ambulances :

No less than 50% of the front side of the vehicle shall be sulfur yellow, RAL-Code 1016 in contrast to no less of 10% brilliant red, RAL Code 9010. The word "AMBULANCE" on yellow background, minimum of 65% of the hood width, shall be in mirror image (reverse reading) for mirror identification by drivers ahead. The word "AMBULANCE" shall be in a contrasting colour and shall be retro-reflective. The front bumper or at least the lower vehicle front up to 70cm or a suitable height within ± 30 cm should be equipped with retro-reflective striping in a chevron pattern sloping downward and away from the centreline of the vehicle at an angle of 45 degrees. Each stripe in the chevron pattern shall be single colour alternating between fluorescent red and silver. Each stripe shall be 6in. (150mm) in width.

B. For Type B Ambulances :

The word "AMBULANCE" on yellow background, not less than 550 mm in width, shall be in mirror image (reverse reading) for mirror identification by drivers ahead. The word "AMBULANCE" shall be in a contrasting colour and shall be retro-reflective. A retro reflective tape in the front of the vehicle shall be provided as per the requirements specified under Rule No. 104 of CMVR for the category of vehicle used to make an Ambulance vehicle.

Side: The side of the vehicle should be equipped with a two lined red retro-reflective Battenburg pattern on the white ground colour. Starting at the vehicle front the Battenburg squares, with a size of 25cm x 25cm for Type C and D Ambulances and at least 12cm x 12cm for Type B Ambulances, should reach approximately the middle of the vehicle length and end in a top square, followed by an "AMBULANCE" marking. The "AMBULANCE" marking should be at least 80% of the Battenburg squares height high. The word "AMBULANCE" shall be in a contrasting colour to the white background and shall be retro-reflective. The front half of the Battenburg pattern should be red/yellow squares and rear half should be in red squares on white background as shown in figures above. The bottom line of the Battenburg pattern should be at least 25cm above the bottom line of the vehicles chassis,. Displayed on the upper half of the left side

should be a retro-reflective “Star of Life” symbol, with a size of 40cm x 40cm for Type C and D Ambulances and 24cm x 24cm for Type B Ambulances, and a retro-reflective emergency number logo, with a size of 40cm x 75cm for Type C and D Ambulances and 24cm x 45cm for Type B Ambulances. The vertical centre of both of them should be positioned at similar height. Contour markings in form of a continuous or non-continuous retro-reflecting yellow stripe (each part 3cm x 10cm) should be applied to the side profile to enhance conspicuity of the vehicle. In Type B, C and D ambulances, the words “Patient Transport”, “Basic Life Support” and “Advanced Life Support” shall be marked respectively above/below/adjacent to the word ambulance in size no less than 50% of the size of the word “AMBULANCE”.

Rear:

A. For C and D Category ambulance :

B.

No less than 50% of the rear of the vehicle should be equipped with a chevron pattern sloping downward and away from the centreline of the vehicle at an angle of 45 degrees. Each stripe in the chevron pattern shall be single colour alternating between retro-reflective red and yellow. Each stripe shall be 6in. (150mm) in width. To ensure that the standard rear lights of the vehicle are not camouflaged by the chevron striping, the chevron striping must provide a distance of no less than 10cm to the standard rear lights. The word “AMBULANCE” on yellow background, minimum of 65% in width of the rear facing side of the vehicle but not smaller than 70cm in width, must be displayed on the rear. The word “AMBULANCE” shall be in a contrasting colour and shall be retro-reflective. Displayed on the left back window should be a retro-reflective “Star of Life” symbol, with a size of 85% of the window, and on the right back window a retro-reflective emergency number logo with the same size. In case of a single window at the rear, size of “Star of Life” symbol and the emergency number logo shall be 85% of half of the window. The rear bumper should be provided with the same chevron pattern as the front one.

Contour markings in form of a continuous or non-continuous retro-reflecting silver stripe should be applied to the rear profile to enhance conspicuity of the vehicle.

C. For B Category Ambulances : The word “AMBULANCE” on yellow background, not less than 550 mm in width, must be displayed on the rear. The word “AMBULANCE” shall be in a contrasting colour and shall be retro-reflective. Displayed on the left back window shall be a “Star of Life” symbol, with a size of 85% of the window, and on the right back window the emergency number logo with the same size. In case of a single window at the rear, size of “Star of Life” symbol and the emergency number logo shall be 85% of half of the window. A retro reflective tape in the rear of the vehicle shall be provided as per the requirements specified under Rule No. 104 of CMVR for the category of vehicle used to make an Ambulance vehicle.

In Type A Ambulances, at least the words “FIRST RESPONDER” shall be used instead of “AMBULANCE”. The other requirements of Conspicuity

improvement Items and Emblems may be optional depending on the space availability of the vehicle.

Note : 2-Wheeled and 3-Wheeled vehicles may also be used as Type A Ambulances.

(iii) Emblems

Emblems defined as such by this Ambulance Conspicuity requirement are government/ private / operator signs, corporate identities (XXX) and every other sign, symbol, marking or striping not referred to in the “Conspicuity Improving Items” section. These emblems are only allowed in a non-reflecting manner and the size can't be bigger than 60% of the “AMBULANCE” markings. Ambulance Calling Number (YYY) if available must be displayed prominently on the side and back of the Road ambulance.

Notes :

- (1) Modifications required in location and dimensions of conspicuity items and emblems specified in para (ii) and para (iii) required due to vehicle design shall be permitted.
- (2) The Emergency number logo shall be fitted by the user. At the time of homologation of the vehicle, the manufacturer shall only identify the space for fixing the same.
- (3) Emblems shall not be fitted on glasses which can be slided or rolled down in such a way that visibility of emblems is adversely affected. In such a case, it shall be permitted to shift the position of emblems to a location feasible as per exterior design of the vehicle. Further, it shall be permitted to modify the size of emblem and size / location of C2I markings given in clause (ii) above to suit the exterior design of the vehicle.

(iv) Warning lights

Type A and B Road Ambulances shall have a single blue color flasher (commonly known as beacon) fitted on the top of the vehicle.

Type C and D Road Ambulances shall have warning lights as follows:

All warning lights have to be mounted rectangular to the horizontal ground. They must provide 100% of their intensity in a vertical angle of ± 4 degrees and 50% in a vertical angle of ± 8 degrees. The minimum intensity is for blue and red lights at 100cd at daylight and 200cd in the night. The horizontal minimum angle should be at least 45 degrees. All lights must flash between 2Hz and 4Hz and should be mounted as on the graphic below

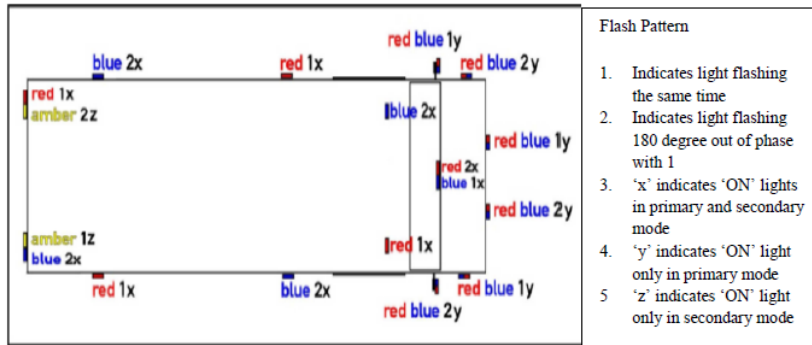

Lights marked with “red blue” must show red and blue in one piece one at a time. In daytime they must flash red in nighttime they must flash blue. Two lights have to be mounted in the lower middle windshield only flashing to the outside of the car. All lights should be flashing as shown in the graphic above. To switch from Primary into Secondary Mode there has to be one switch that allows only one mode.

(v) Sirens

In Type A, B, C and D Road Ambulances, all siren loudspeakers have to be mounted on the front of the vehicle. Hidden installation is allowed. The main sound direction must be in driving direction. Permitted are wail and yelp signals that cycle between 10-18 respectively 150-250 per minute at an sound pressure level of 110dB(A) to 120dB(A). The sirens should be tested in accordance with IS 1884 (though not covered in the standard). The frequency range must be at least one octave and should be between 500Hz and 2.000Hz. An additional electronic air horn can be used. Further there should be a public address system that can be worked at all times ergonomically from the driver’s seat. The siren switch can only be used if the warning lights are on.

ANNEXURE-2

(See 4.1)

**TECHNICAL INFORMATION TO BE SUBMITTED BY THE ROAD
AMBULANCE MANUFACTURER**

(These are additional to the specifications submitted for
CMVR compliance as per AIS-007)

1.0	Details of Ambulance manufacturer	
1.1	Name and Address :	
1.2	Telephone No :	
1.3	Fax. No. :	
1.4	E mail address :	
1.5	Contact person :	
1.6	Name of model :	
1.7	Category of Ambulance A/B/C/D	
1.8	Name of variants, if any:	
1.9	Type and General commercial description (s) :	
1.10	Plant/(s)of manufacture :	
2.0	Vehicle Chassis Characteristics	
2.1	Chassis types approved for Body installation :	
2.2	Type of Control (normal control/Full forward control etc.) :	
2.3	Number of Axles and wheels :	
2.4	Chassis (overall drawing) :	
2.5	Valid CMVR certificate for the base Vehicle (If available)	
2.6	Frame Type :	
2.7	Cross sectional view :	
2.8	Position and arrangement of engine:	
2.9	Dimension (in mm) (Specify drawing reference) :	
2.9.1	Length mm :	
2.9.2	Width mm :	
2.9.3	Height (Unladen) mm :	
2.9.4	Wheel base mm :	
2.9.5	Wheel track mm :	

2.9.5.1	Front :	
2.9.5.2	Rear :	
2.9.6	Body overhang mm :	
2.9.6.1	Front end :	
2.9.6.2	Rear end :	
2.10	Category of Base vehicle :	
3.0	Body :	
3.1	Dimension drawing and photograph of the vehicle with representative body :	
3.2	Range of vehicle dimension (overall):	
3.3	Dimension drawing of the body depicting chassis connecting members :	
3.4	Material used for construction :	
3.4.1	Structural Material :	
3.4.2	Size of sections :	
3.5	Method of construction :	
	(Brief construction method)	
3.6	Patient Handling Equipment	
3.6.1	Main Stretcher / Undercarriage	
3.6.1.1	Make	
3.6.1.2	Model	
3.6.1.3	Type	
3.6.1.4	ID/Part Number	
3.6.1.5	Dimensions of Stretcher	
3.6.1.6	Loading Angle	
3.6.1.7	Loading Height	
3.6.1.8	Stretcher loading capacity	
3.12	Recognition of Ambulance	
3.12.1	Engineering drawing indicating arrangement for the external visibility for recognition and emblems.	

4.0	Vehicle Dimensions	
4.1	Clearance	
4.2	Minimum road clearance :	
4.3	Road clearance from floor :	
4.4	Approach angle :	
4.5	Departure Angle :	
4.6	Ramp-over Angle :	
4.7	Weights	
4.7.1	Vehicle kerb weight kg :	
4.7.1.1	Front axle :	
4.7.1.2	Rear axle :	
4.7.1.3	Total :	
4.7.2	Gross vehicle weight kg :	
4.7.3	Maximum permissible axle weights kg	
4.7.3.1	Front axle:	
4.7.3.2	Rear axle:	
4.9	Tyres	
4.9.1	No. and arrangement of wheels :	
4.9.1.1	Front :	
4.9.1.2	Rear :	
4.9.1.3	Other :	
4.9.2	Inflation pressure – Un laden :	
4.9.2.1	Front :	
4.9.2.2	Rear :	
4.9.2.3	Other	
4.9.3	Inflation pressure –Laden :	
4.9.3.1	Front :	
4.9.3.2	Rear :	
4.9.3.3	Other :	
5.0	Body Panels	
5.1	Outer Panels :	
5.1.1	Material :	

5.1.2	Thickness :	
5.2	Inner Panels :	
5.2.1	Material :	
5.2.2	Thickness :	
5.3	Roof Panels :	
5.3.1	Material :	
5.3.2	Thickness :	
5.4	Floor Panels :	
5.4.1	Material :	
5.4.2	Thickness :	
5.4.3	Type of anti-slip coating :	
6.0	Service Doors	
6.1	No. of Service Doors :	
6.2	Position of Service Doors :	
6.3	Dimension of Service Door :	
6.3.1	Front Height :	
6.3.2	Width :	
6.3.3	Rear Height :	
6.3.4	Width :	
6.3.5	Middle Height :	
6.3.6	Width :	
7.0	Window	
7.1	Type of window	
7.3	Area (H x W in sq. m) :	
8.0	Seat anchorage layout drawing (with anchorage cross section and hardware used details)	
9.0	Driver Partition :	
9.1	Dimension of partition with respect to rear edge of driver seat : (rear most position of driver seat)	
10.0	External Projections (Compliance established to IS:13943 -1994 ----- Yes / No)	

11.0	Door locks and hinges	
11.1	Door lock :	
11.1.1	Name of Manufacturer :	
11.1.2	Identification mark :	
11.2	Door hinge :	
11.2.1	Name of Manufacturer :	
11.2.2	Identification mark :	
11.3	Safety glass	
11.3.1	Front wind shield (laminated) :	
11.3.1.1	Make	
11.3.1.2	Identification :	
11.3.1.3	Type (flat/curved, clear/tinted) :	
11.3.1.4	Thickness mm :	
11.3.1.5	No. of pIECes :	
11.3.1.6	Radius of curvature (If curved) :	
11.3.2	Side Windows:	
11.3.2.1	Make	
11.3.2.2	Identification	
11.3.2.3	Type (flat/curved, clear/tinted, toughened) :	
11.3.2.4	Thickness mm :	
11.3.2.5	Radius of curvature (If curved) :	
11.3.3	Rear Window:	
11.3.3.1	Make	
11.3.3.2	Identification	
11.3.3.3	Type (flat/curved, clear/tinted, toughened) :	
11.3.3.4	Thickness mm :	
11.3.3.5	Radius of curvature (If curved) :	
11.3.4	Wind Screen Wiper	
11.3.4.1	Type :	
11.3.4.2	No. of wipers :	
11.3.5	Wiper motor :	
11.3.5.1	Name of Manufacturer :	
11.3.5.2	Type and identification :	
11.3.5.3	Rated voltage :	

11.3.5.4	Frequency of wiping :	
11.3.6	Wiper arm :	
11.3.6.1	Length :	
11.3.6.2	Name of Manufacturer :	
11.3.6.3	Identification Mark:	
11.3.7	Wiper blade :	
11.3.7 .1	Length :	
11.3.7 .2	Name of Manufacturer :	
11.3.7 .3	Identification Mark:	
11.3.8	Rubber material :	
11.3.8.1	Type of fixing (As per IS:7827)	
11.3.9	Wind Screen Washer	
11.3.9.1	Name of Manufacture: :	
11.3.10	Type :	
11.3.10.1	Number of nozzles :	
11.3.10.2	Spray Area :	
11.3.10.3	Identification Number:	
12.0	Equipment for occupant's safety	
12.1	Driver Seat belt :	
12.1.1	Name of Manufacture: :	
12.1.2	Type :	
12.1.3	Number :	
12.1.4	Identification Number:	
12.2	Driver Seat belt anchorage :	
12.2.1	Name of Manufacturer :	
12.2.2	Type :	
12.2.3	Number :	
12.3	Head restraint :	
12.3.1	Name of Manufacturer :	
12.3.2	Type :	
12.4	Seat :	
12.4.1	Number of Patients and attendant seats	
12.4.2	Position	
12.4.3	Name of Manufacturer :	

12.4.4	Type :	
12.4.5	Frame structure Material :	
12.4.6	Section size:	
12.4.7	Pad material:	
12.4.8	Upholstery :	
12.4.9	Identification Number:	
13.0	Bumper	
13.1	Front Size:	
13.2	Rear Size:	
13.3	Clearance between bumper and body:	
14.0	Fire Extinguisher :	
14.1	Number :	
14.2	Type :	
14.3	Capacity :	
14.5	Name of Manufacturer :	
15.0	Towing devices :	
15.1	Type :	
15.2	Name of manufacturer :	
15.3	Capacity :	
15.4	Identification Number / Part No	
16.0	Automotive bulbs (To be filled , if different from the valid CMVR Compliance certificate)	
16.1	Head lamp bulb (main and dip)	
16.1.1	Make and Country of origin (if imported) :	
16.1.2	Designation as per AIS-034 :	
16.2	Parking Lamp bulb – Front :	
16.2.1	Make and Country of origin (if imported) :	
16.2.2	Designation as per AIS-034 :	
16.3	Parking Lamp bulb – Rear :	
16.3.1	Make and Country of origin (if imported) :	
16.3.2	Designation as per AIS-034 :	
16.4	Direction indicator lamp bulb - front :	

16.4.1	Make and Country of origin(if imported) :	
16.4.2	Designation as per AIS-034 :	
16.5	Direction indicator lamp bulb – rear :	
16.5.1	Make and Country of origin (if imported) :	
16.5.2	Designation as per AIS-034 :	
16.6	Direction indicator lamp bulb – side :	
16.6.1	Make and Country of origin (if imported) :	
16.6.2	Designation as per AIS-034 :	
16.7	Front Position Lamp bulb :	
16.7.1	Make and Country of origin (if imported) :	
16.7.2	Designation as per AIS-034 :	
16.8	Rear Position Lamp (tail lamp)Bulb :	
16.8.1	Make and Country of origin (if imported) :	
16.8.2	Designation as per AIS-034 :	
16.9	Stop lamp bulb :	
16.9.1	Make and Country of origin (if imported) :	
16.9.2	Designation as per AIS-034 :	
16.1	Number plate lamp bulb :	
16.10.1	Make and Country of origin (if imported) :	
16.10.2	Designation as per AIS-034 :	
16.11	End out Marker bulb :	
16.11.1	Make and Country of origin (if imported) :	
16.11.2	Designation as per AIS-034 :	
16.12	Reversing lamp bulb :	
16.12.1	Make and Country of origin (if imported) :	
16.12.2	Designation as per AIS-034 :	
16.13	Stop Lamp Bulb (S3) :	
16.13.1	Make and Country of origin (if imported) :	
16.13.2	Designation as per AIS-034 :	
16.14	Front Fog Lamp Bulb:	
16.14.1	Make and Country of origin (if imported) :	
16.14.2	Designation as per AIS-034 :	
16.15	Rear Fog Lamp Bulb :	

16.15.1	Make and Country of origin (if imported) :	
16.15.2	Designation as per AIS-034 :	
16.16	Side Marker Lamp Bulb :	
16.16.1	Make and Country of origin (if imported) :	
16.16.2	Designation as per AIS-034 :	
17.0	Head Lamp (To be filled if different from the valid CMVR Compliance certificate)	
17.1	Name of Manufacturer :	
17.2	Type and Identification :	
17.3	Number and colour :	
18.0	Tail lamp (To be filled if different from the valid CMVR Compliance certificate)	
18.1	Name of Manufacturer :	
18.2	Type and Identification :	
18.3	Number and colour :	
19.0	Parking lamp (To be filled if different from the valid CMVR Compliance certificate)	
19.1	Front :	
19.1.1	Name of Manufacturer :	
19.1.2	Type and Identification :	
19.1.3	Number and colour :	
19.2	Rear :	
19.2.1	Name of Manufacturer :	
19.2.2	Type and Identification :	
19.2.3	Number and colour	
20.0	Stop lamp (To be filled if different from the valid CMVR Compliance certificate)	
20.1	Name of Manufacturer :	
20.2	Type and Identification :	
20.3	Number and colour :	
21.0	Reversing lamp (To be filled if different from the valid CMVR Compliance certificate)	
21.1	Name of Manufacturer :	
21.2	Type and Identification :	
21.3	Number and colour :	

22.0	Direction indicator lamp (To be filled if different from the valid CMVR Compliance certificate)	
22.1	Front :	
22.1.1	Name of Manufacturer :	
22.1.2	Type and Identification :	
22.1.3	Number and colour :	
22.2	Rear :	
22.2.1	Name of Manufacturer :	
22.2.2	Type and Identification :	
22.2.3	Number and colour :	
22.3	Side :	
22.3.1	Name of Manufacturer :	
22.3.2	Type and Identification :	
22.3.3	Number and colour :	
22.3.4	Type of flasher :	
23.0	Number Plate Lamp (To be filled if different from the valid CMVR Compliance certificate)	
23.1	Name of Manufacturer :	
23.2	Type and Identification :	
23.3	Number and colour :	
24.0	Warning Lamp (To be filled if different from the valid CMVR Compliance certificate)	
24.1	Name of Manufacturer :	
24.2	Type and Identification :	
24.3	Number and colour :	
25.0	Siren- Compliance to IS 1884 – Yes / No)	
25.1	Make :	
25.2	Model :	
25.3	ID / Part Number :	
26.0	Reflector (To be filled if different from the valid CMVR Compliance certificate)	
26.1	Rear :	

26.2	Name of Manufacturer :	
26.3	Type and Identification :	
26.4	Number and colour :	
26.5	Area (cm ²):	
26.6	Side :	
26.7	Name of Manufacturer :	
26.8	Type and Identification :	
26.9	Number and colour :	
26.10	Area (cm ²) :	
27.0	Top light (To be filled if different from the valid CMVR Compliance certificate)	
27.1	Name of Manufacturer: :	
27.2	Type and Identification :	
27.3	Number and colour :	
28.0	Internal Lighting and Illumination	
28.1	Driver Cab lighting :	
28.1.1	Type :	
28.1.2	Name of Manufacturer :	
28.1.3	Number :	
28.1.4	Illumination intensity (Lux) :	
28.2	Patient Compartment Lighting :	
28.2.1	Type :	
28.2.2	Name of Manufacturer :	
28.2.3	Number :	
28.2.4	Illumination intensity (Lux) :	
28.3	Other Area Lighting :	
28.3.1	Type :	
28.3.2	Name of Manufacturer :	
28.3.3	Number :	
28.3.4	Illumination intensity (Lux) :	
29.0	Electrical Circuit :	
29.1	Circuit Diagram (attach details):	

29.2	Number of battery(ies) provided other than the vehicle battery :	
29.3	Details of Alternator :	
30.0	Electrical Cables :	
30.1	Name of Manufacturer :	
30.2	Conductor Cross section :	
30.3	Insulation Class :	
31.0	Fuse :	
31.1	Type and Make :	
31.2	Name of Manufacturer :	
32.0	Master switch for electrical :	
32.1	Type and Make :	
32.2	Name of Manufacturer :	
33.0	Flammability Test as per IS 15061: 2002 (as applicable) :	
34.0	Interior fitting compliance as per AIS-047 established - Yes/No :	
35.0	Instrument Panel (Dash Board) :	
35.1	Make :	
35.2	Identification No. / Part No. :	
35.3	Material :	
35.4	Drawing showing the mounting details, over all size and all control switches with dimensions :	
35.5	Additional details for interior fitting tests to be given (if test is already conducted, this information need not be submitted) :	
35.6	Instrument Panel Variants with photographs (With / without Airbag, Music system, AC)	
35.7	Material used for instrument Panel :	
35.8	Drawings :	
35.9	Drawing of Grab handle with cross section :	
35.10	Drawing of lamp assembly mounted at roof	
35.11	Name of manufacturer of the Interior fitting components :	

36.0	Air Conditioning and Heating Performance Tests(Clause 4.5.4) Compliance Established –Yes / No	
37.0	Acceleration Test (Clause 4.2.1 and IS:11851-2002) Compliance Established – Yes / No	
38.0	Water Proofing Test (IS:11865-1995) – Compliance Established –Yes / No	
39.0	Dust Ingress Test (IS:11739-1997) Compliance Established –Yes / No	

ANNEXURE 3
(See Introduction)

COMPOSITION OF AISC PANEL

Name	Organization
Dr. Shakti Kumar Gupta (Chairman)	Head, Department of Hospital Administration and Medical Superintendent (Dr. Rajendra Prasad Centre of Ophthalmic Sciences and JPNA Trauma Centre), AIIMS, New Delhi
Dr. D.K. Pawar	Professor, Department of Anaesthesiology, AIIMS, New Delhi
Brig. (Med.) Pawan Kapoor	Army Medical Corps, HQ 16 Core, C/o 56 APO.
Mr. A. Akbar Badusha	Deputy Director and Head, Vehicle Evaluation Lab, ARAI, Pune
Dr. A.R. Goyal	Director, Finance, MoRTH, Govt. of India
Mr. Rajeev Lochan	Director (RS), MoRTH, Govt of India
Col. Sunil Kant	Directing Staff, Officers Training College, AMC Centre and College, Lucknow
Mr. S.N. Das	C.E. (Mech), MoRTH, Govt. of India
Mr. R.P. Khandelwal	CGM (Safety), NHAI, Govt. of India
Dr. Chaman Prakash	CMO, Dt.GHS, MoHFW, Govt. of India
Dr. Ritu Rawat	Senior Medical Superintendent, Apollo Hospitals
Lt. Col. S.K. Patnaik	Medical Officer, Hospital Services, Military Hospital, Hissar
Dr. Angel Rajan Singh	Senior Resident Administrator, Department of Hospital Administration, AIIMS, New Delhi
Mr. R.K. Chawla	DGM (CM), NHAI, Govt. of India
Mr. K.C. Sharma	E.E. (M), MoRTH, Govt. of India
Mr. Jashvant Prajapati	Chief Operating Officer at GVK EMRI-Gujarat
Dr. G.V. Ramanarao	Head, EM Learning Centre and Research, GVK EMRI
Mr. B.N. Mishra	Under Secretary (RS), MoRTH, Govt. of India
Mr. Kamal Gulati	AIIMS, New Delhi
Mr. K.K.Gandhi	Representing SIAM and its members

ANNEXURE 4
(See Introduction)
COMMITTEE COMPOSITION *
Automotive Industry Standards
Committee

Chairman	
Shri Shrikant R. Marathe	Director The Automotive Research Association of India, Pune
Members	Representing
Representative from	Ministry of Road Transport and Highways (Dept. of Road Transport and Highways), New Delhi
Representative from	Ministry of Heavy Industries and Public Enterprises (Department of Heavy Industry), New Delhi
Shri S. M. Ahuja	Office of the Development Commissioner, MSME, Ministry of Micro, Small and Medium Enterprises, New Delhi
Shri P.C.Joshi	Bureau of Indian Standards, New Delhi
Director Shri D. P. Saste (Alternate)	Central Institute of Road Transport, Pune
Director	Indian Institute of Petroleum, Dehra Dun
Director	Vehicles Research and Development Establishment, Ahmednagar
Representatives from	Society of Indian Automobile Manufacturers
Shri T.C. Gopalan	Tractor Manufacturers Association, New Delhi
Shri Uday Harite	Automotive Components Manufacturers Association of India, New Delhi

Member Secretary
Mrs. Rashmi
Urdhwareshe
Sr. Deputy Director
The Automotive Research Association of India,
Pune

* At the time of approval of this Automotive Industry Standard (AIS)