

**AMENDMENT NO. 1
TO
AIS -035
Automotive Vehicles -The Arrangement of
Foot Controls of Vehicles**

1.0 Page No.3/8 , clause 5.8, line 4 and 5:

Add words “(Ref. Fig. 2 of Annex 3)”, after the words “-----with three pedals,
” and “(Ref. Fig. 1 of Annex 3).” after the words “---- with two pedals.”

PRINTED BY
THE AUTOMOTIVE RESEARCH ASSOCIATION OF INDIA
P. B. NO. 832, PUNE 411 004
ON BEHALF OF
AUTOMOTIVE INDUSTRY STANDARDS COMMITTEE
UNDER
CENTRAL MOTOR VEHICLE RULES - TECHNICAL STANDING COMMITTEE
SET-UP BY
MINISTRY OF SHIPPING, ROAD TRANSPORT & HIGHWAYS
(DEPARTMENT OF ROAD TRANSPORT & HIGHWAYS)
GOVERNMENT OF INDIA
February 2007

AUTOMOTIVE INDUSTRY STANDARD

**Automotive Vehicles -
The Arrangement of
Foot Controls of Vehicles**

PRINTED BY
THE AUTOMOTIVE RESEARCH ASSOCIATION OF INDIA
P.B. NO. 832, PUNE 411 004

ON BEHALF OF
AUTOMOTIVE INDUSTRY STANDARDS COMMITTEE

UNDER
CENTRAL MOTOR VEHICLE RULES – TECHNICAL STANDING COMMITTEE

SET-UP BY
MINISTRY OF SHIPPING, ROAD TRANSPORT & HIGHWAYS
(DEPARTMENT OF ROAD TRANSPORT & HIGHWAYS)
GOVERNMENT OF INDIA

October 2006

Status chart of the Standard to be used by the purchaser
for updating the record

Sr. No.	Corr- igenda	Amend- ment	Revision	Date	Remark	Misc.

General remarks:

INTRODUCTION

The Government of India felt the need for a permanent agency to expedite the publication of standards and development of test facilities in parallel when the work on the preparation of the standards is going on, as the development of improved safety critical parts can be undertaken only after the publication of the standard and commissioning of test facilities. To this end, the Ministry of Surface Transport (MOST) has constituted a permanent Automotive Industry Standards Committee (AISC) vide order No.RT-11028/11/97-MVL dated September 15, 1997. The standards prepared by AISC will be approved by the permanent CMVR Technical Standing Committee (CTSC). After approval, the Automotive Research Association of India, (ARAI), Pune, being the Secretariat of the AIS Committee, has published this standard. For better dissemination of this information ARAI may publish this document on their web site.

Foot controls in a vehicle do not require the driver to see them while driving. The driver needs to be familiar with the foot controls of different makes of vehicles. In this regard the arrangement of the foot controls is important for safety.

While preparing this AIS considerable assistance is derived from ECE R 35 (Revision 1, Erratum) – Uniform provisions concerning the approval of Vehicles with regard to the Arrangement of Foot Controls

The Automotive Industry Standards Committee responsible for preparation of this standard is given in Annex 4

**Automotive Vehicles -
The Arrangement of Foot Controls of Vehicles**

CONTENTS

Sr. No.	Description	Page No.
1.	Scope	1/8
2.	References	1/8
3.	Definitions	1/8
4.	Technical information to be submitted by the vehicle manufacturer	2/8
5.	Requirements	2/8
ANNEXES		
Annex 1	: Three dimensional reference system	4/8
Annex 2	: Reference data concerning seating positions	5/8
Annex 3	: Arrangement of foot controls	6/8
Annex 4	: Committee composition of Automotive Industry Standards Committee	8/8

Automotive Vehicles - The Arrangement of Foot Controls of Vehicles

1.0 SCOPE

This standard applies to vehicles of category M1 with regard to the arrangement and mode of operation of the foot controls.

2.0 REFERENCES

2.1	AIS-053	Automotive Vehicles - Types - Terminology
2.2	IS:13749 :1993	Automotive Vehicle - Determination of H - Point Method of Test

3.0 DEFINITIONS

For the purpose of this standard:

- 3.1 **"Approval of a vehicle"** means the approval of a vehicle type with regard to the foot controls as specified in clause 1.
- 3.2 **"Vehicles of category M1"** means a motor vehicle as defined in AIS-053.
- 3.3 **"Vehicle type"** means a category of motor vehicles which do not differ in respect of the structure and internal arrangements which may affect the location and operation of the foot controls;
- 3.4 **"Accelerator pedal"** means a foot control by which the engine power output can be varied;
- 3.5 **"Service-brake pedal"** means a foot control by which the service-braking device can be operated;
- 3.6 **"Clutch pedal"** means the foot control of the device designed to engage the engine with or disengage it from the transmission and the road wheels;
- 3.7 **"Transverse plane"** means a plane perpendicular to the median longitudinal plane of the vehicle;
- 3.8 **"Longitudinal plane"** means a plane parallel to the median longitudinal plane of the vehicle;
- 3.9 **"Reference Plane"** "P" (See Figure 1) means a transverse plane passing through point "A" and perpendicular to the orthogonal projection of the line joining point "R" to point "A" when projection is taken on a longitudinal plane passing through the "R" point.
- 3.9.1 "A" is a point on the surface of the accelerator pedal 200 mm from point "B";

3.9.2 "B" is the fixed point on the vehicle corresponding to the heel point, as established by the vehicle manufacturer;

3.10 "Walls" means fixed structural members (e.g. transmission tunnel; wheel arches; side trim panels).

4.0 TECHNICAL INFORMATION TO BE SUBMITTED BY THE VEHICLE MANUFACTURER

4.1 The application for approval of a vehicle type with regard to the arrangement of foot controls shall be submitted by the vehicle manufacturer.

4.2 It shall be accompanied by the following documents in triplicate, and by the following particulars:

4.2.1 Drawings, on an appropriate scale and in sufficient detail, of the parts of the structure considered to be referred to by the requirements of this Standard;

4.3 A vehicle representative of the type to be approved shall be submitted to the test agency responsible for conducting the approval tests.

4.4 Vehicle manufacturer shall submit reference data concerning seating positions of driver as per Annex 2 to test agency

5.0 REQUIREMENTS (See Annex 3)

5.1 The foot controls shall be arranged in the following order from left to right, as observed from the driver's seat: clutch pedal if any; service-brake pedal; accelerator pedal.

5.2 It shall be possible to place the left foot normally in a position of rest on the floor surface or foot rest such that it is not trapped by the pedals.

5.3 It shall be possible to actuate any pedal over its full travel without inadvertently operating floor-switches or other foot controls.

5.4 The seating reference point "R" shall be measured by the procedure for determining the "H" point and actual torso angle for seating position in motor vehicles as per IS:13749-1993.

The three dimensional reference system shall be as given in Annex 1

5.5 The distance, shown at "E" in Annex 3, between the contour points of the orthogonal projections on to plane "P" of the accelerator-pedal and service-brake-pedal bearing surfaces shall be ≤ 100 mm and ≥ 50 mm.

5.6 The distance F in Fig.2 of Annex 3 between the orthogonal projections of the service-brake-pedal and the clutch-pedal bearing surfaces on to the reference plane "P" shall be ≥ 50 mm.

- 5.7 The distance G in Fig.2 of Annex 3, between the contour points of the orthogonal projection of the clutch pedal on to plane “P” and the intersection of the nearest wall with plane “P” shall be ≥ 50 mm.
- 5.8 The distances, respectively shown as “H” and “J” in Annex 3, between the projection of the service-brake pedal on to the reference plane “P” and the intersection of each of the walls with that plane shall be ≥ 130 mm to the right and ≥ 160 mm to the left for vehicles with three pedals, and ≥ 130 mm to the right and ≥ 120 mm to the left for vehicles with two pedals.

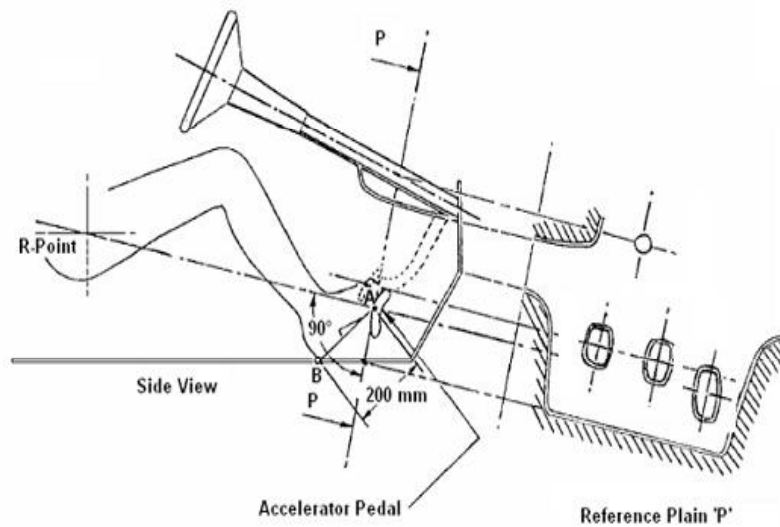
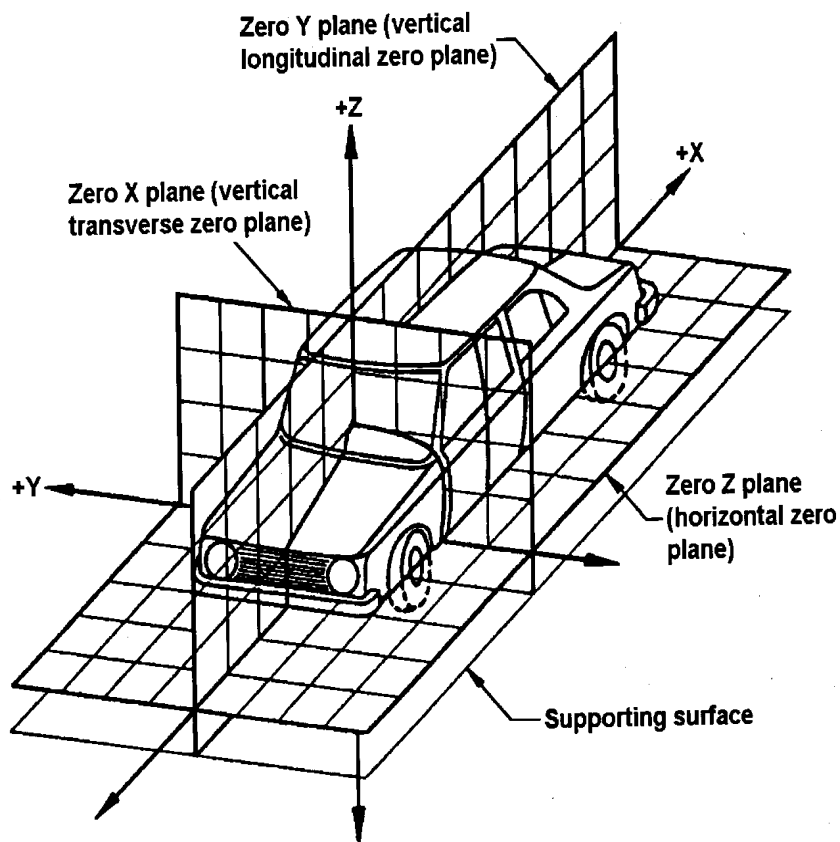

Figure. 1
(See clause 3.9)
Arrangements of Foot Controls

ANNEX 1
(See clause 5.4)

THREE DIMENSIONAL REFERENCE SYSTEM

1. The three-dimensional reference system is defined by three orthogonal planes established by the vehicle manufacturer (see figure).*
2. The vehicle measuring attitude is established by positioning the vehicle on the supporting surface such that the coordinates of the fiducial marks correspond to the values indicated by the manufacturer.
3. The coordinates of the “R” point and the “H” point are established in relation to the fiducial marks defined by the vehicle manufacturer.



Figure

Three-dimensional reference system

* The reference system correspondence to ISO standard 4130-1978

ANNEX 2

(See 4.4)

REFERENCE DATA CONCERNING SEATING POSITIONS

1. Coding of reference data

Reference data are listed consecutively for each seating position. Seating positions are identified by a two-digit code. The first digit is an Arabic numeral and designates the row of seats, counting from the front to the rear of the vehicle. The second digit is a capital letter which designates the location of the seating position in a row, as viewed in the direction of forward motion of the vehicle; the following letters shall be used:

- L = left
- C = centre
- R = right

2. Description of vehicle measuring attitude

2.1. Coordinates of fiducial marks

- X.....
- Y.....
- Z.....

3. List of reference data

3.1. Seating position:

3.1.1. Coordinates of "R" point

- X.....
- Y.....
- Z.....

3.1.2. Design torso angle:

3.1.3. Specifications for seat adjustment *

- horizontal:.....
- vertical:.....
- angular:.....
- torso angle:.....

Note: List reference data for further seating positions under 3.2, 3.3, etc.

* Strike out what does not apply.

ANNEX 3
(See 5.0)

ARRANGEMENT OF FOOT CONTROLS

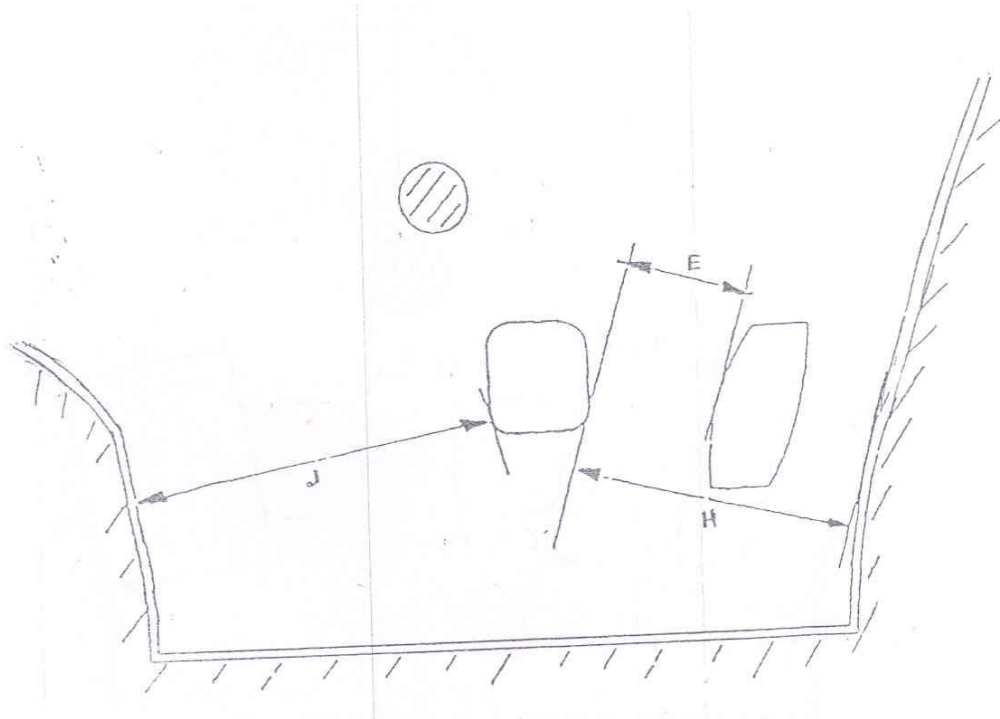

	Max (mm)	Min (mm)
E	100	50
H	--	130
J	--	120

Figure 1
Two Pedals - Automatic Transmission

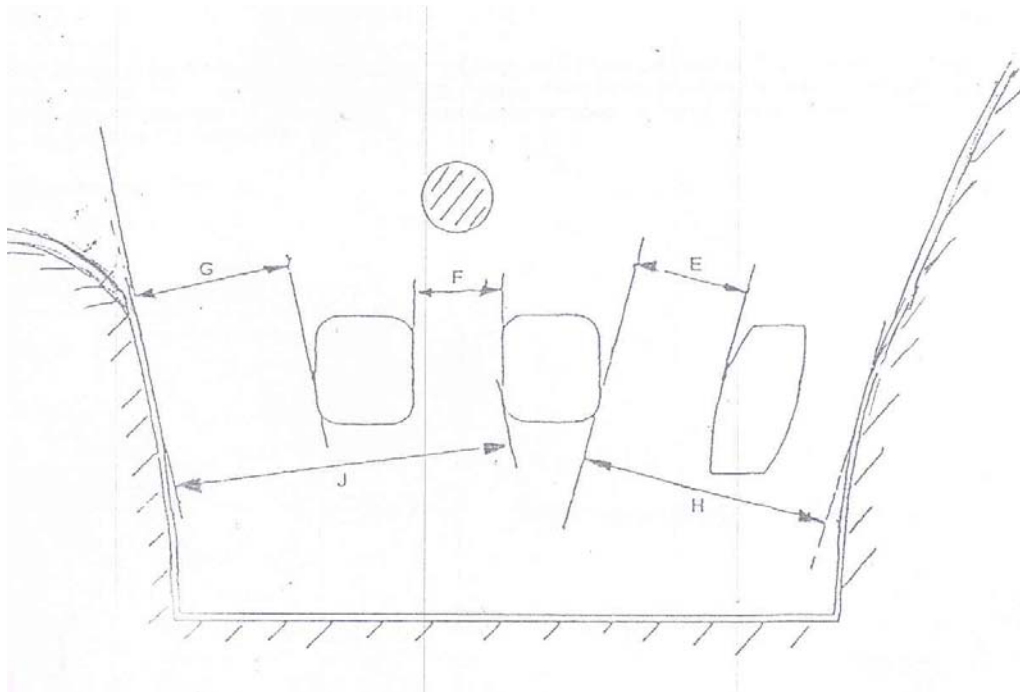

	Max (mm)	Min (mm)
E	100	50
F	--	50
G	--	50
H	--	130
J	--	160

Figure 2
Three - pedals - Conventional Transmission

ANNEX 4
(See Introduction)
COMMITTEE COMPOSITION *
Automotive Industry Standards Committee

Chairman	
Shri Shrikant R. Marathe	Director The Automotive Research Association of India, Pune
Members	Representing
Shri S. K. Mishra	Ministry of Shipping, Road Transport & Highways (Dept. of Road Transport & Highways), New Delhi
Shri Sushil Kumar	Ministry of Heavy Industries & Public Enterprises (Department of Heavy Industry), New Delhi
Shri J. K. Arya	Office of the Development Commissioner, Small Scale Industries, Ministry of Small Scale Industries, New Delhi
Shri S. K. Chauduri Shri P. C. Joshi (Alternate)	Bureau of Indian Standards, New Delhi
Dr. G. K. Sharma Shri D. P. Saste (Alternate)	Central Institute of Road Transport, Pune
Director	Indian Institute of Petroleum, Dehra Dun
Dr. C. L. Dhamejani Dr. N. Karuppaiah (Alternate)	Vehicles Research & Development Establishment, Ahmednagar
Shri Dilip Chenoy	Society of Indian Automobile Manufacturers
Shri T.C. Gopalan Shri Ramakant Garg (Alternate)	Tractor Manufacturers Association, New Delhi
Shri K.N.D. Nambudiripad	Automotive Components Manufacturers Association, New Delhi
Shri G. P. Banerji	Automotive Components Manufacturers Association, New Delhi

Member Secretary
Mrs. Rashmi Urdhwareshe
Deputy Director
The Automotive Research Association of India, Pune

* At the time of approval of this Automotive Industry Standard (AIS)