

AIS-012

AUTOMOTIVE INDUSTRY STANDARD

**Performance Requirements of
Lighting and Light-Signaling Devices
for Motor Vehicle having more than
Three Wheels, Trailer and
Semi-Trailer**

PRINTED BY:

THE AUTOMOTIVE RESEARCH ASSOCIATION OF INDIA
P.B.NO.832, PUNE 411 004

ON BEHALF OF:

AUTOMOTIVE INDUSTRY STANDARDS COMMITTEE

UNDER

CENTRAL MOTOR VEHICLES RULES – TECHNICAL STANDING COMMITTEE

SET-UP BY

MINISTRY OF ROAD TRANSPORT & HIGHWAYS
GOVERNMENT OF INDIA

December 2004

Status chart of the Standard to be used by the purchaser
for updating the record

Sr. No.	Corrige nda.	Amend- ment	Revision	Date	Remark	Misc.

General Remarks :

INTRODUCTION

The Government of India felt the need for a permanent agency to expedite the publication of standards and development of test facilities in parallel when the work on the preparation of the standards is going on, as the development of improved safety critical parts can be undertaken only after the publication of the standard and commissioning of test facilities. To this end, the Ministry of Surface Transport (MOST) vide order No. RT-11028/11/97-MVL dated September 15,1997.The standard prepared by AISC will be approved by the permanent CMVR Technical Standing Committee (CTSC). After approval, the Automotive Research Association of India,(ARAI), Pune , being the Secretariat of the AIS Committee, has published this standard . For better dissemination of this information ARAI may publish this document on their Web site.

Performance of lighting and light-signalling devices is a safety requirement. This standard prescribes the requirements of such devices installed on motor vehicle having more than three wheels, trailer and semi-trailer .

Performance requirements of lighting and light-signalling devices for two and three wheeler are covered in AIS-010 and those for agricultural tractor are covered in AIS-062.

Performance requirements for retro-reflectors to be installed on motor vehicles are covered in AIS-057

Considerable assistance has been taken from the following ECE Regulations in preparing this standard:

ECE R 4 Rev. 1-Amd.3 (Supp.9 to Org. Ver.)	Uniform Provisions concerning the Approval of Devices for the Illumination of Rear Registration Plates of Motor Vehicles (Except Motor Cycles) and their Trailers
ECE R 6 Rev. 3-Amd.1 (Supp.10 to 01 Series of Amd.)	Uniform Provisions concerning the Approval of Direction Indicators for Motor Vehicles and their Trailers
ECE R 7 Rev. 3-Amd.1 (Supp.6 to 02 Series of Amd.)	Uniform Provisions concerning the Approval of Front and Rear Position (Side) Lamps, Stop-Lamps and End-outline Marker Lamps for Motor Vehicles (Except Motor Cycles) and their Trailers
ECE R 19 Rev. 3-Amd. 4 (Supp.9 to 02 Series of Amd.)	Uniform Provisions concerning the Approval of Motor Vehicles Fog Lamps.

ECE R 23 Rev. 1-Amd. 4 (Supp.8 to Org. Ver.)	Uniform Provisions concerning the Approval of Reversing Lamps for Power-Driven Vehicles and their Trailers
ECE R 38 Rev. 1-Amd. 2 (Supp.7 to Org. Ver.)	Uniform Provisions concerning the Approval of Rear Fog Lamps for Power-Driven Vehicles and their Trailers
ECE R 77 Rev. 1-Amd. 1 (Supp.6 to Org. Ver.)	Uniform Provisions concerning the Approval of Parking Lamps for Power-Driven Vehicles.
ECE R 91 Amd. 4 (Supp.4 to Org. Ver.)	Uniform Provisions concerning the Approval of Side-Marker Lamps for Motor Vehicles and their Trailers
ECE R 98 Amd. 2 (Supp.2 to Org. Ver.)	Uniform Provisions concerning the Approval of Motor Vehicle Headlamps Equipped with Gas-Discharge Light Sources
ECE R 112 Amd. 2 (Supp.2 to Org. Ver.)	Uniform Provisions Concerning the Approval of Motor Vehicle Headlamps Emitting an Asymmetrical Passing Beam or a Driving Beam or Both and Equipped with Filament Lamps.

While preparing this standard, as per decisions of CMVR-TSC, following was considered:

- Additional environmental and vibration tests ;
- The new and old colour coordinates of ECE regulations have been retained as alternatives;
- The size of number plate for checking the registration plate (mark) illuminating lamp has been changed to the size prescribed in CMVR ;
- Requirement of Bend Lighting for headlamps is not considered at this juncture.

The Automotive Industry Standards Committee responsible for this standard is given in Annex:N.

**Performance Requirements of Lighting and
Light-Signaling Devices for Motor Vehicle having more
than Three Wheels, Trailer and Semi-Trailer**

1.0 SCOPE

This standard lays down performance requirements of lighting and light signaling devices for motor vehicle having more than three wheels, trailer and semi-trailer.

2.0 REFERENCE

The following standards are necessary adjuncts to this standard.

AIS-008/2001 Installation Requirements of Lighting and Light - Signalling Devices for Motor Vehicle having more than Three Wheels, Trailer and Semi-Trailer excluding Agricultural Tractor and Special Purpose Vehicle

AIS-034 Automobile Lamps

3.0 Lighting and light - signalling devices fitted on motor vehicles as specified in para. 1.0 shall meet the requirements specified in para. 5.0 and 6.0.

4.0 DEFINITIONS

4.1 In addition to following, definitions referred in paragraph 4.0 of AIS-008/2001 shall be applicable

4.1.1 **“Lens”** means the outermost component of the headlamp (unit), which transmits light through the illuminating surface;

4.1.2 **“Coating”** means any product or products applied in one or more layers to the outer face of a lens;

4.1.3 **“Head lamps of different types”** means headlamps, which differ in such essential respects as:

4.1.3.1 The trade name or mark

4.1.3.2. the characteristics of the optical system;

- 4.1.3.3. The inclusion or elimination of components capable of altering the optical effects by reflection, refraction, absorption and/or deformation during operation.
- 4.1.3.4. The kind of beam produced (dipped-beam, main-beam or both);
- 4.1.3.5. The materials constituting the lenses and coating, if any;
- 4.1.3.6. The category of filament lam used.
- 4.1.4. **Headlamps of different Classes (A or B)** mean headlamps identified by particular photometric provisions.
- 4.1.5. **“Ballast”** means the electrical supply of the gas-discharge light source. This ballast may be partly or completely inside or outside the headlamp.
- 4.1.6. **“Matched pair”** means the set of lamps of the same function on the left and right-hand side of the vehicle;
- 4.1.7. **“Headlamps equipped with gas-discharge light sources of different types”** are headlamps which differ in such essential respects as:
 - 4.1.7.1. The trade name or mark
 - 4.1.7.2. The characteristics of the optical system;
 - 4.1.7.3. The inclusion or elimination of components capable of altering the optical effects by reflection, refraction, absorption and/or deformation during operation. However, the fitting or elimination of filters intended solely to change the colour of the beam and not its light distribution does not entail a change of type;
 - 4.1.7.4. The kind of beam produced (dipped-beam, main-beam or both);
 - 4.1.7.5. The materials constituting the lenses and coating, if any;
- 4.1.8. **“Light-transmitting components”** means any part of the headlamp which transmits light for illumination, such as outer and inner lenses, lens or reflector coatings.
- 4.1.9. **“Front fog lamps of different types”** are front fog lamps which differ in such essential respects as:
 - 4.1.9.1. The trade name or mark
 - 4.1.9.2. The characteristics of the optical system;

- 4.1.9.3. The inclusion of components capable of altering the optical effects by reflection, refraction, absorption and/or deformation during operation.
- 4.1.9.4. The category of filament lamp;
- 4.1.9.5. The materials constituting the lenses and coating, if any;
- 4.1.10. **“Front and rear position (side) lamps, stops lamps and end-outline marker lamps of different types”** means lamps which differ in each side category in such essential respects as;
 - 4.1.10.1. The trade name or mark
 - 4.1.10.2. The characteristics of the optical system, (levels of intensity, light distribution angles, type of filament lamp, etc.)
 - 4.1.10.3. The system used to reduce illumination at night-in the case of stop-lamps with two levels of intensity.
- 4.1.11. **“Direction indicators of different types”** are different indicators which differ in such essential respects as;
 - 4.1.11.1. The trade name or mark
 - 4.1.11.2. The characteristics of the optical system, (levels of intensity, light distribution angles, etc.)
 - 4.1.11.3. The category of direction indicators;
 - 4.1.11.4. The colour of the filament lamp.
- 4.1.12. **“Reversing lamps of different types”** are reversing lamps which differ in such essential respects as,
 - 4.1.12.1. The trade name or mark;
 - 4.1.12.2. The characteristics of the optical system;
 - 4.1.12.3. The inclusion of components capable of altering the optical effects by reflection, refraction or absorption; and
 - 4.1.12.4.1. The category of filament lamp.
- 4.1.13. **“Parking lamps of different types”** are parking lamps which differ in such essential respects as;
 - 4.1.13.1. The trade name or mark;

- 4.1.13.2. The characteristics of the optical system;
- 4.1.13.3. The category of filament lamp.
- 4.1.14. **“Type in relation to side-marker lamps”** means side-marker lamps which do not differ in such essential respects as;
 - 4.1.14.1. the trade name or mark;
 - 4.1.14.2. The characteristics of the optical system, (level of intensity, light distribution angles, type of filament lamp, etc.)
- 4.1.15. **“Rear fog lamps of different types”** are rear fog lamps, which differ in such essential respects as
 - 4.1.15.1. the trade name or mark;
 - 4.1.15.2. The characteristics of the optical system,
 - 4.1.15.3. The category of lamp.
- 4.1.16 **“Rear registration plate (mark) illuminating lamps of different types”** means lamps which differ in such essential respects as :
 - 4.1.16.1 the trade name or mark;
 - 4.1.16.2 The characteristics of the optical system ((level of intensity, light distribution angles, type of filament lamp, light source module etc.)
 - 4.1.16.3 The angle of incidence of the light on the surface of the plate.

5.0 LIGHTING AND LIGHT-SIGNALLING DEVICES SHALL MEET THE PHOTOMETRIC AND COLORIMETRIC REQUIREMENTS AS GIVEN IN FOLLOWING ANNEXES

5.1 Main beam headlamp and dipped beam headlamp	Annex: A1, A2, A3
5.2 Gas discharge headlamp	Annex: B1 , B2. B3
5.3 Front fog lamp	Annex:C1, C2, C3
5.4 Front and rear position lamp, stop lamp and end-out line marker lamp	Annex: D1, D2, D3
5.5 Direction indicator lamp and hazard warning lamp	Annex: E1, E2, E3
5.6 Reversing lamp	Annex: F1, F2, F3
5.7 Parking lamp	Annex: G1, G2, G3
5.8 Side marker lamp	Annex: H1, H2, H3
5.9 Rear fog lamp	Annex: J1, J2, J3
5.10 Rear registration plate (mark) illuminating device	Annex: K1, K2, K3

5.11 In the case of devices designed for use with replaceable filament lamp or gas-discharge light source, they shall be of category listed in AIS-034 or corresponding standard applicable at the time of Type Approval of device or those permitted in standard considered to be alternate as per rule 92(3) of CMVR. The lamp holders of such devices shall be suitable for cap of such filament lamps or gas-discharge light sources

5.12 In the case of devices with non-replaceable light source or light source module, the non-replaceable light source or light source module shall comply with the requirement given to Annex :M

Note: Non-replaceable light sources / light source module are not applicable for head lamps and front fog lamp.

6.0 APPLICABLE TESTS TO THE LIGHTING AND LIGHT-SIGNALING DEVICES

6.1 The applicable tests to the lighting and light-signaling devices are shown in the **Table-1**

6.2 Lighting and light-signaling devices shall meet the requirements of environmental tests as specified in **Annex: L**, when tested with prescribed test procedures given in the same **Annex**

7.0 SAMPLES TO BE SUBMITTED FOR TESTING

7.1 For photometric and colorimetric tests two samples – one L/H and one R/H- shall meet the specified requirements. The samples tested for photometric tests may be further used for colorimetric tests

7.2 For all other environmental tests a separate sample shall be tested. However tests can be combined as per manufacturers' option.

7.3 For the test of plastic material of which the lenses of headlamp are made the following samples shall also be submitted:

7.3.1 thirteen lenses. In case of headlamps equipped with gas-discharge light source fourteen lenses

7.3.2 Six * of these lenses may be replaced by six * samples of material at least 60 x 80 mm in size, having a flat or convex outer surface and a substantially flat area (radius of curvature not less than 300 mm) in the middle measuring at least 15 x 15 mm;

* Note : In case of headlamps equipped with gas-discharge light source ten.

7.3.3 Every such lens or sample of material shall be produced by the method to be used in mass production;

AIS-012

- 7.3.4 A reflector to which the lenses can be fitted in accordance with the manufacturer's instructions.
- 7.3.5 The materials making up the lenses and coatings, if any, shall be accompanied by the test report of the characteristics of these materials and coatings if they have already been tested.
- 7.3.6 For testing the UV-resistance of light transmitting components made of plastic material against UV radiation of gas-discharge light sources inside the headlamp:
 - 7.3.6.1. One sample each of the relevant material as being used in the headlamp or one headlamp sample containing these. Each material sample shall have the same appearance and surface treatment - if any - as intended for use in the headlamp to be approved.
 - 7.3.6.2 The UV-resistance testing of internal materials to light source radiation is not necessary if low-UV-type gas-discharge light sources are being applied as specified in AIS-034 or if provisions are taken, to shield the relevant headlamp components from UV radiation, e.g. by glass filters.

8.0 REQUIREMENTS OF CONFORMITY OF PRODUCTION ⁽¹⁾

- 8.1. Devices approved under this standard shall be so manufactured as to conform to the type approved by meeting the requirements set forth in the relevant annexes.
- 8.2 The test agency may at any time verify the conformity control methods applied in each production facility. The normal frequency of these verifications shall be once every two years.
- 8.3. Penalties for noncompliance of conformity of production shall be as detailed in AIS-037

9.0 FOR TYPE-APPROVAL

9.1 Technical Specifications to be submitted:

At the time of application, the manufacturer shall declare to the test agency the information given in **Table 2**.

10.0 CHANGES IN TECHNICAL SPECIFICATION

- 10.1 Every modification pertaining to the information, even if the changes are not technical in nature declared in accordance with para 9.1 shall be intimated by the manufacturer to the certifying agency.

(1) This provision will come into force after AIS-037 is notified for implementation

If the changes are in parameters not related to the provisions, no further action need be taken.

If the changes are in parameters related to the provisions, the Testing Agency, which has issued the certificate of compliance, may then consider, whether,

- 10.1.1 the model with the changed specifications still complies with provisions;
- or,
- 10.1.2 any further verification is required to establish compliance.
- 10.2 For considering whether testing is required or not, guidelines given in para 11.0 (Criteria for Extension of Approval) shall be used.
- 10.3. In case of 10.1.2, tests for only those parameters which are affected by the modifications need be carried out
- 10.4. In case of fulfillment of criterion of para 10.1.1 or after results of further verification as per para of 10.1.1 are satisfactory, the approval of compliance shall be extended for the changes carried out.

11. CRITERIA FOR EXTENSION OF APPROVAL

Till the details are finalized, the Criteria shall be as agreed between the test agency and manufacturer.

12. MARKING

- 12.1 The devices shall have, in a legible and indelible way, the following markings:
- 12.2 Trade name or mark of the manufacturer
- 12.3 Indication of filament lamp or gas-discharge light source category or categories provided, if the devices are fitted with replaceable filament lamps or gas-discharge light source

Note: This is not applicable, if the devices are fitted with non-replaceable light sources.

- 12.4 On the prototype for type approval the marking may be provided by suitable temporary methods and need not necessary be obtained from the tools used for series production.
- 12.5 In case of headlamp maximum luminous intensity expressed by a reference mark (See para A2.3.2.1.2)

12.6 In case of headlamp equipped with gas-discharge light source on their light emitting surface a center of reference as shown in Annex: B8

12.7 In case of front and rear position lamp, stop lamp and end-out line marker lamps operating at other than the nominal rated voltages of 6V, 12V or 24 V respectively, by the application of an additional supply system or having secondary mode, must bear a marking denoting the rated secondary design voltage, if the additional supply is not part of the device.

Table: 1
(See para 6.1)
LIST OF APPLICABLE TESTS

Sr. No.	Name of the Test	Lighting * Device with -out Plastic Lens	Lighting * Device with Plastic Lens	Light – Signalling Devices **
1	Photometry	√	√	√
2	Colorimetry	√	√	√
3	Vibration Test	√	√	√
4	Resistance to Oil Test	---	---	√
5	Corrosion Resistance Test	√	√	√
6	Dust Test	√	√	√
7	Moisture Test	√	√	√
8	Thermal Shock Resistance Test	√	---	---
9	High Voltage (flash) Test	√	√	---
10	Warpage Test for Devices with Plastic Lenses	---	√	√
11.	Fuel Resistance Test	---	---	√
12	Tests for Stability of Photometric Performance of Headlamps in operation	√	√	---

* Lighting devices include main-beam headlamp, dipped-beam headlamp, front fog lamp.

** All other devices are considered as light-signalling devices

Table: 2
(See para 9.1)

**TECHNICAL INFORMATION TO BE SUBMITTED BY THE
MANUFACTURER FOR TYPE- APPROVAL**

1. Manufacturer's name & address
2. Telephone No
3. FAX. No.
4. E mail address
5. Contact person
6. Plant/(s) of manufacture.
7. The intended function(s) of the device.
8. Drawings, in triplicate ,in sufficient detail to permit identification of the type and setting out the geometrical conditions (if applicable for category S3 stop lamp, the rear window)under which it is fitted to the vehicle, together with the direction of observation which must be taken into account as the reference axis during the tests (horizontal angle $H = 0^\circ$, vertical angle $V = 0^\circ$) and the point which must be taken as the center of reference during these tests; in the case of a headlamp the drawings must show a vertical (axial) section and a head-on view with, where appropriate, details of the lens fluting; the drawings must also illustrate the position intended for the mandatory component type-approval mark and, where appropriate, additional symbols in relation to the rectangle for that mark.
9. A brief technical description of device giving details, in particular, with the exception of lamps with non-replaceable light sources, the category or categories of filament lamps prescribed as listed in AIS-034
10. In case the light source is replaceable, Category, rated voltage and quantity of filament lamp
11. Colour of the light emitted from the device :
- 10 **Following specific information regarding lighting and light-signalling devices:**
- 12.1 **Headlamp:**
- 12.1.1 Whether the headlamp is intended to provide both a dipped-beam and a main-beam or only one of these beams;
- 12.1.2 if the headlamp is equipped with an adjustable reflector, the mounting position(s) of the headlamp in relation to the ground and the longitudinal median plane of the vehicle;
- 12.1.3 Whether it concerns a Class A or B headlamp;
- 12.1.4 drawings representing a frontal view of the headlamp, with details of lens ribbing if any, and the cross-section;

- 12.1.4.1 If the headlamp is equipped with an adjustable reflector, an indication of the mounting position(s) of the headlamp in relation to the ground and the longitudinal median plane of the vehicle, if the headlamp is for use in that (those) position(s) only;

12.2 Headlamp equipped with gas-discharge light source:

- 12.2.1 Whether the headlamp is intended to provide a dipped-beam, a main-beam or both;
- 12.2.2 See 12.1.2
- 12.2.3 the maximum vertical angles above and below the nominal position(s) which the aiming device can achieve;
- 12.2.4 which light sources are energized when the various beam combinations are used;
- 12.2.5 drawings must show the headlamp in vertical (axial) section and in front elevation, with main details of the optical design including the flutings, if applicable.
- 12.2.6 A brief technical specification including the make and types of the ballast(s), where it applies.

12.3 Front fog lamp:

- 12.3.1 drawings representing a frontal view of the front fog lamp, with details of lens ribbing if any, and the cross-section;

12.4 Front and rear position lamp, Stop lamp and End- outline marker lamp:

- 12.4.1 The purpose or purposes for which the device submitted for approval is intended and whether it may also be used in an assembly of two lamps of the same kind/type;
- 12.4.2 Category of stop lamp : S1,S2 , S3
In case of category S3 stop lamp, whether it is intended to be mounted outside or inside (behind the rear window) the vehicle
- 12.4.3 At the choice of the manufacturer, it will specify that the device may be installed on the vehicle with different inclinations of the reference axis in respect to the vehicle reference planes and to the ground or rotate around its reference axis; these different conditions of installation shall be indicated in the information.
- 12.4.4 In case of Category S3 stop lamp, which is intended to be mounted inside the vehicle, the technical description shall contain the specification of the optical properties (transmission, colour, inclination etc.) of the rear window(s).
- 12.4.5 In case of stop lamp with two levels of intensity, an arrangement diagram and specification of the characteristics of the system ensuring the two levels of intensity. Manufacturer shall provide two samples of parts constituting the system which ensures two level of intensity.

- 12.4.6 In the case of a Category S3 stop lamp which is intended to be mounted inside the vehicle, a sample plate or sample plates (in case of different possibilities) having the equivalent optical properties corresponding to those of the actual rear window(s).

12.5 Direction Indicator lamp

- 12.5.1 Category or to which of the Categories 1, 1a, 1b, 2a, 2b, 3, 4, 5 or 6 according to Appendix-1 to Annex: E2 the direction indicator belongs and, if it belongs to Category 2, whether it has one level of intensity (Category 2a) or two levels of intensity (Category 2b) and whether the direction indicator may also be used in an assembly of two lamps of the same category.
- 12.5.2 See para 12.4.3
- 12.5.3 For a direction indicator of category 2b, an arrangement diagram and a specification of the characteristics of the system ensuring the two level of intensity. Also two samples of the parts constituting the system which ensure the two levels of intensity.

12.6 Reversing lamp

- 12.6.1 See para 12.4.3

12.7 Parking lamp

- 12.7.1 See para 12.4.3

12.8 Side-marker lamp

- 12.8.1 See para 12.4.3

12.9 Rear fog lamp

- 12.9.1 See para 12.4.3

12.10 Rear registration plate (mark) illuminating lamp :

- 12.10.1 Whether the device intended to illuminate a wide plate or tall plate
- 12.10.1 Drawings showing geometrically the position in which the illuminating device is to be fitted in relation to the space to be occupied by the registration plate, and the outlines of the area adequately illuminated.

ANNEX : A1

(See para 5.1)

**REQUIREMENTS FOR MAIN-BEAM HEADLAMP AND
DIPPED-BEAM HEADLAMP****A1.1 GENERAL REQUIREMENTS FOR HEADLAMPS**

A1.1.1 Each sample shall conform to the specifications set forth in Annex: A1, A2, A3 and Annex: L

A1.1.2 Headlamps shall be so made as to retain their prescribed photometric characteristics and to remain in good working order when in normal use, in spite of the vibrations to which they may be subjected.

A1.1.2.1 Headlamps shall be fitted with a device enabling them to be so adjusted on the vehicles as to comply with the rules applicable to them. Such a device need not be fitted on units in which the reflector and the diffusing lens cannot be separated, provided the use of such units is confined to vehicles on which the headlamp setting can be adjusted by other means.

Where a headlamp providing a dipped-beam and a headlamp providing a main-beam, each equipped with its own filament lamp, are assembled to form a composite unit the adjusting device shall enable each optical system individually to be duly adjusted.

A1.1.2.2 However, these provisions shall not apply to headlamp assemblies whose reflectors are indivisible. For this type of assembly the requirements of paragraph A2.3 of Annex :A2 shall apply.

A1.1.3 The headlamp shall be equipped with filament lamp(s) approved according to AIS 034. Any Filament Lamp complying with AIS 034 may be used, provided that no restriction on the application is made in the table of contents of AIS 034 ⁽¹⁾.

A1.1.4 The components by which a filament lamp is fixed to the reflector shall be so made that, even in darkness, the filament lamp can be fixed in no position but the correct one. ⁽²⁾

(1) HIR1 and/or H9 filament lamps shall only be permitted to produce dipped-beam in conjunction with the installation of headlamp cleaning device(s) conforming to AIS-083 (under formulation). In addition, with respect to vertical inclination, the provision of paragraph 6.2.6.2.2. of AIS-008/2001 shall not be applied when these lamps are installed.

This restriction shall apply as long as there is no general agreement on the use of levelling devices and headlamp cleaners with respect to the level of the performance of the headlamp.

(2) A headlamp is regarded as satisfying the requirements of this paragraph if the filament lamp can be easily fitted into the headlamp and the positioning lugs can be correctly fitted into their slots even in darkness.

AIS-012

- A1.1.5 The filament lamp holder shall conform to the characteristics given in AIS 034. The holder data sheet relevant to the category of filament lamp used applies.
- A.1.1.6 Headlamp designed shall satisfy the requirements of left-hand traffic.
- A1.1.7 Complementary test shall be done according to Annex :A4 to ensure that in use there is no excessive change in photometric performance.
- A1.1.8 If the lens of the headlamp is of plastic material, tests shall be done according to the requirements of Annex : A5.
- A1.1.9 On headlamps designed to provide alternately a main-beam and a Dipped-beam, any mechanical, electromechanical or other device incorporated in the headlamp for switching from one beam to the other shall be so constructed that:
 - A1.1.9.1 The device is strong enough to withstand 50,000 operations without suffering damage despite the vibrations to which it may be subjected in normal use.
 - A1.1.9.2 In the case of failure it shall automatically obtain the dipped-beam position.
 - A1.1.9.3 Either the dipped-beam or the main-beam shall always be obtained without any possibility of the mechanism stopping in between two positions
 - A1.1.9.4 The user cannot, with ordinary tools, change the shape or position of the moving parts.

ANNEX : A2

(See para 5.1 and A1.1.1.)

**PHOTOMETRIC TEST PROCEDURE AND
ILLUMINATION REQUIREMENTS FOR MAIN-BEAM
HEADLAMP AND DIPPED-BEAM HEADLAMP****A2.1 GENERAL PROVISIONS**

- A2.1.1 Headlamps shall be so made that they give adequate illumination without dazzle when emitting the dipped-beam, and good illumination when emitting the main-beam.
- A2.1.2 The illumination produced by the headlamp shall be determined by means of a vertical screen set up 25 m forward of the headlamp and at right angles to its axes as shown in Figure A1.
- A2.1.3 The headlamps shall be checked by means of a standard (reference or etalon) filament lamp designed for a rated voltage of 12V⁽¹⁾. During the checking of the headlamp, the voltage at the terminals of the filament lamp shall be regulated so as to obtain the reference luminous flux as indicated at the relevant data sheet of AIS-034.
- A2.1.4 The headlamp shall be considered acceptable if it meets the requirements of this Annex:A2 with at least one standard (reference or etalon) filament lamp, which may be submitted with the headlamp.

A2.2 PROVISION CONCERNING DIPPED-BEAM

- A2.2.1 The dipped-beam must produce a sufficiently sharp "cut-off" to permit a satisfactory adjustment with its aid. The "cut-off" must be a horizontal straight line on the side opposite to the direction of the traffic for which the headlamp is intended; on the other side it must not extend beyond either the broken line HV H1 H4 formed by a straight line HV H1 making a 45° angle with the horizontal and the straight line H1 H4, 25 cm above the straight line hh, or the straight line HV H3, inclined at an angle of 15° above the horizontal (see Figure A1). A "cut-off" extending beyond both line HV H2 and line H2H4 and resulting from a combination of the two above possibilities shall in no circumstances be permitted.
- A2.2.2. The headlamp shall be so aimed that:
- A2.2.2.1 In the case of headlamps designed to meet the requirements of left-hand traffic, the "Cut-off" on the right half of the screen⁽²⁾ is horizontal;
- A2.2.2.2 This horizontal part of the "cut-off" is situated on the screen 25 cm below the level hh (See Figure A1);

(1) 24V rated voltage lamps also can be approved to this standard

(2) The test screen must be sufficiently wide to allow examination of the cut-off over a range of at least 5° on either side of the Line vv.

- A2.2.2.3 The "elbow" of the "cut-off" is on line vv ⁽¹⁾
- A2.2.3 When so aimed, the headlamp need, if its approval is sought solely for provision of a dipped-beam⁽²⁾, comply only with the requirements set out in paragraphs A2.2.5 to A2.2.7 below; if it is intended to provide both a dipped-beam and a main-beam, it shall comply with the requirements set out in paragraphs from A2.2.5 to A2.2.7 and A 2.3.
- A2.2.4 Where a headlamp so aimed does not meet the requirements set out in paragraphs A2.2.5 to A2.2.7 and A 2.3, its alignment may be changed, provided that the axis of the beam is not displaced laterally by more than 1⁰ (= 44 cm) to the right or left ⁽³⁾. To facilitate alignment by means of the "cut-off", the headlamp may be partially occulted in order to sharpen the "cut-off".
- A2.2.5 The illumination produced on the screen by the dipped-beam shall meet the following requirements:

Point on measuring screen		Required Illumination in lux	
Headlamps for Left-Hand Traffic		Class A Headlamp	Class B Headlamp
Point B	50 R	≤ 0.4	≤ 0.4
Point	75 L	≥ 6	≥ 12
Point	75 R **	≤ 12 **	≤ 12
Point	50 R **	≤ 15 **	≤ 15
Point	50 L	≥ 6	≥ 12
Point	50 V	--	≥ 6
Point	25 R	≥ 1.5	≥ 2
Point	25 L	≥ 1.5	≥ 2
Any point in zone III		≤ 0.7	≤ 0.7
Any point in zone IV		≥ 2	≥ 3
Any point in zone I		≤ 20	≤ 2E (*)
(*) E is the actually measured value in points 50R respectively 50 L			
** The required illumination at these points is not applicable to lamps of R2 & HS1 category.			

A2.2.6 There shall be no lateral variations detrimental to good visibility in any of the zones I, II, III, and IV.

- (1) If the beam does not have a cut-off with a clear elbow the lateral adjustment shall be effected in the manner which best satisfies the requirements for illumination at points 75L & 50L for left hand traffic.
- (2) Such a special " dipped-beam" headlamp may incorporate a main-beam not subject to requirements.
- (3) The limit of realignment of 1⁰ towards the right or left is not incompatible with upward or down ward vertical realignment. The latter is limited only by the requirements of paragraph A2.3 However, the horizontal part of the "cut-off" should not extend beyond the line hh (the provisions of paragraph A2.3 are not applicable to headlamps intended to meet the requirements of relevant Annexes only for provision of a dipped-beam).

A2.2.7 The illumination values ⁽¹⁾ in zones "A" and "B" as shown in Figure A2 shall be checked by the measurement of the photometric values of points 1 to 8 on this Figure; these values shall lie within the following limits: ⁽¹⁾

$$1+2+3 \geq 0.3 \text{ lux,} \quad \text{and}$$

$$4+5+6 \geq 0.6 \text{ lux,} \quad \text{and}$$

$$0.7 \text{ lux} \geq 7 \geq 0.1 \text{ lux} \quad \text{and}$$

$$0.7 \text{ lux} \geq 8 \geq 0.2 \text{ lux}$$

A2.3 PROVISIONS CONCERNING MAIN-BEAM

A2.3.1 In case of a headlamp designed to provide a main-beam and a dipped-beam, measurements of the illumination produced on the screen by the main-beam shall be taken with the same headlamp alignment as for measurements under paragraphs A2.2.5 to A2.2.7 above; in the case of a headlamp providing a main-beam only, it shall be so adjusted that the area of maximum illumination is centered on the point of intersection of the lines hh and vv; such a headlamp need meet only the requirements referred to in paragraph A2.3. Where more than one light source is used to provide the main-beam, the combined functions shall be used to determine the maximum value of the illumination (E_M)

A2.3.2 The illumination produced on the screen by the main-beam shall meet the following requirements:

A2.3.2.1 The point of intersection (HV) of the lines hh and vv shall be situated within the isolux representing 80% of maximum illumination. This maximum value (E_M) shall be not less than 32 lux for Class A headlamps and 48 lux for Class B headlamps. The maximum value shall in no case exceed 240 lux; moreover, in the case of a combined passing and driving headlamp, this maximum value shall not be more than 16 times the illumination measured for the dipped-beam at point 75L.

A2.3.2.1.1 The maximum luminous intensity (I_M) of the main-beam expressed in thousands of candelas shall be calculated by means of the formula:

$$I_M = 0.625 E_M$$

A2.3.2.1.2 The reference mark (I'_M) indicating this maximum intensity shall be obtained by means of the formula:

$$I'_M = I_M / 3 = 0.208 E_M$$

(1) Illumination values in any point of Zones A & B, which also lies with Zone III, shall not exceed 0.7 lux

This value shall be rounded to whichever is the nearest of the following: 7.5-10-12.5-17.5-20-25-27.5-30-37.5-40-45-50.

- A2.3.2.2. Starting from point HV, horizontally to the right and left the illumination shall be not less than 16 lux for Class A headlamp and 24 lux for Class B headlamp up to a distance of 1.125 m and not less than 4 lux for Class A headlamp and 6 lux for Class B headlamp up to a distance of 2.25 m.
- A2.4.** In the case of headlamps with an adjustable reflector, the requirements of paragraphs A2.2 and A2.3 are applicable for each mounting position indicated in relevant para. of Table : 2. For verification, the following procedure shall be used:
- A2.4.1 Each applied position is realized on the test goniometer with respect to a line joining the center of the light source and point HV on the aiming screen. The adjustable reflector is then moved into such a position that the light pattern on the screen corresponds to the aiming prescriptions of paragraphs A2.2.1 to A2.2.2.3 and/or A2.3.1;
- A2.4.2. With the reflector initially fixed according to paragraph A2.4.1, the headlamp must meet the relevant photometric requirements of paragraphs A2.2 and A2.3;
- A2.4.3 Additional tests are made after the reflector has been moved vertically ± 2 degrees or at least into the maximum position, if less than 2 degrees, from its initial position by means of the headlamps adjusting device. Having re-aimed the headlamp as a whole (by means of the goniometer for example) in the corresponding opposite direction, the light output in the following directions shall be controlled and lie within the required limits:
- Dipped-beam: Points HV and 75L respectively;
Main-beam: E_M and Point HV (percentage of E_M)
- A2.4.4 If the applicant has indicated more than one mounting position, the procedure of paragraphs A2.4.1 to A2.4.3 shall be repeated for all the other positions;
- A2.4.5 If the applicant has not asked for special mounting positions, the headlamp shall be aimed for measurements of paragraphs A2.2 and A2.3 with the headlamps adjusting device in its mean position. The additional tests of paragraph A2.4.3 shall be made with the reflector moved into its extreme positions (instead of $\pm 2^\circ$) by means of the headlamps adjusting device.

A2.5 The screen illumination values referred to in paragraphs A2.2.5 to A2.2.7 and A2.3 above shall be measured by means of a photoreceptor, the effective area of which shall be contained within a square of 65mm side.

A2.6 STANDARD (Reference) HEADLAMP ⁽¹⁾

A headlamp shall be deemed to be a standard (reference) headlamp if it:

A2.6.1 Satisfies the above-mentioned requirements for approval;

A2.6.2 Has an effective diameter of not less than 160mm;

A2.6.3 Provides with a standard filament lamp, at the various point and in the various zones referred to in paragraph A2.2.5., illumination equal to:

A2.6.3.1 Not more than 90% of the maximum limits and

A2.6.3.2 Not less than 120% of the minimum limits prescribed in the table in paragraph A2.2.5.

(1) Different values may be accepted provisionally. In the absence of definitive specifications, the use of an approved headlamp is recommended

ANNEX : A3
(See para 5.1 and A1.1.1.)

COLORIMETRIC REQUIREMENTS FOR HEADLAMP

The color of light emitted shall be white. Expressed in CIE trichromatic coordinates, the light of beam shall be in following boundaries:

Limit towards blue	:	$x \geq 0.310$
Limit towards yellow	:	$x \leq 0.500$
Limit towards green	:	$y \leq 0.150 + 0.640 x$
Limit towards green	:	$y \leq 0.440$
Limit towards purple	:	$y \geq 0.050 + 0.750 x$
Limit towards red	:	$y \geq 0.382$

ANNEX : A4
(See para A1.1.7)

**TESTS FOR STABILITY OF PHOTOMETRIC
PERFORMANCE OF HEADLAMPS IN OPERATION**

TESTS ON COMPLETE HEADLAMPS

Once the photometric values have been measured according to the prescriptions of this standard, in the point for Emax for main-beam and in points HV, 50 L, B 50 R for dipped-beam a complete headlamp sample shall be tested for stability of photometric performance in operation. "Complete headlamp" shall be understood to mean the complete lamp itself including those surrounding body parts and lamps, which could influence its thermal dissipation.

A4.1 TEST FOR STABILITY OF PHOTOMETRIC PERFORMANCE

The tests shall be carried out in a dry and still atmosphere at an ambient temperature of $23^{\circ}\text{C} \pm 5^{\circ}\text{C}$, the complete headlamp being mounted on a base representing the correct installation on the vehicle.

A4.1.1 Clean headlamp

The headlamp shall be operated for 12 hours as described in paragraph A4.1.1.1. and checked as prescribed in paragraph A4.1.1.2.

A4.1.1.1 Test procedure ⁽¹⁾

The headlamp shall be operated for a period according to the specified time, so that:

A4.1.1.1.1 (a) In the case where only one lighting function (driving or dipped-beam or front fog lamp) is to be approved, the corresponding filament is lit for the prescribed time, ⁽²⁾

(b) In the case of a headlamp with a dipped-beam and one or more main-beams or in case of a headlamp with a dipped-beam and a front fog lamp:

(i) the headlamp shall be subjected to the following cycle until the time specified is reached:

15 minutes, passing-beam filament lit;

5 minutes, all filaments lit.

(1) For the test schedule see Annex A8

(2) When the tested headlamp includes signalling lamps, the latter shall be lit for the duration of the test. In the case of a direction indicator lamp, it shall be lit in flashing mode with an on/off time of approximately one to one.

- (ii) if the applicant declares that the headlamp is to be used with only the dipped-beam lit or only the main-beam(s) lit ⁽¹⁾ at a time, the test shall be carried out in accordance with this condition, activating ⁽²⁾ successively the dipped-beam half of the time and the main-beam(s) (simultaneously) for half the time specified in paragraph A4.1.1. above.
- (c) in the case of a headlamp with a front fog lamp and one or more main-beams:
 - (i) the headlamp shall be subjected to the following cycle until the time specified is reached:
15 minutes, front fog lamp lit;
5 minutes, all filaments lit.
 - (ii) if the applicant declares that the headlamp is to be used with only the front fog lamp lit or only the main-beam(s) lit ⁽¹⁾ at a time, the test shall be carried out in accordance with this condition, activating ⁽²⁾ successively the front fog lamp half of the time and the main-beam(s) (simultaneously) for half the time specified in paragraph A4.1.1 above.
- (d) In case of headlamps with dipped-beam, one or more driving beams and a front fog lamp:
 - (i) the headlamp shall be subjected to the following cycle until the time specified is reached:
15 minutes, passing-beam filament lit;
5 minutes, all filaments lit.
 - (ii) if the applicant declares that the headlamp is to be used with only the dipped-beam lit or only the main-beam(s) ⁽¹⁾ lit at a time, the test shall be carried out in accordance with this condition, activating ⁽²⁾ successively the dipped-beam half of the time and the main-beam(s) for half the time specified in paragraph A4.1.1 above, while the front fog lamp is subjected to a cycle of 15 minutes off and 5 minutes lit for half of the time and during the operation of the main-beam;

(1) Should two or more lamp filaments be simultaneously lit when headlamp flashing is used, this shall not be considered as being normal use of the filaments simultaneously.

(2) When the tested headlamp includes signalling lamps, the latter shall be lit for the duration of the test. In the case of a direction indicator lamp, it shall be lit in flashing mode with an on/off time of approximately one to one.

AIS-012

(iii) if the applicant declares that the headlamp is to be used with only the dipped-beam lit or only the front fog lamp ⁽¹⁾ lit at a time, the test shall be carried out in accordance with this condition, activating ⁽²⁾ successively the dipped-beam half of the time and the front fog lamp for half of the time specified in paragraph A4.1.1 above, while the main-beam(s) is(are) subjected to a cycle of 15 minutes off and 5 minutes lit for half of the time and during the operation of the dipped-beam;

(iv) if the applicant declares that the headlamp is to be used with only the dipped-beam lit or only the main-beam(s) ⁽¹⁾ lit or only the front fog lamp ⁽¹⁾ lit at a time, the test shall be carried out in accordance with this condition, activating ⁽²⁾ successively the dipped-beam one third of the time, the main-beam(s) one third of the time and the front fog lamp for one third of the time specified in paragraph A4.1.1 above.

A4.1.1.1.2. Test voltage

The voltage shall be adjusted so as to supply 90 per cent of the maximum wattage specified in standard AIS 034 for the filament lamp(s) used.

The applied wattage shall in all cases comply with the corresponding value of a filament lamp of 12 V rated voltage, except if the applicant for approval specifies that the headlamp may be used at a different voltage. In the latter case, the test shall be carried out with the filament lamp whose wattage is the highest that can be used.

A4.1.1.2. Test results

A4.1.1.2.1. Visual inspection

Once the headlamp has been stabilized to the ambient temperature, the headlamp lens and the external lens, if any, shall be cleaned with a clean, damp cotton cloth. It shall then be inspected visually;

no distortion, deformation, cracking or change in colour of either the headlamp lens or the external lens, if any, shall be noticeable.

A4.1.1.2.2. Photometric test

To comply with the requirements of this Regulation, the photometric values shall be verified in the following points:

(1) See foot note (1) on page no. 21

(2) See foot note (2) on page no. 21

Dipped-beam: 50 L - B 50 R - HV.

Main-beam: Point of E_{\max}

Another aiming may be carried out to allow for any deformation of the headlamp base due to heat (the change of the position of the cut-off line is covered in paragraph A4.2 of this Annex).

A 10 per cent discrepancy between the photometric characteristics and the values measured prior to the test is permissible including the tolerances of the photometric procedure.

A4.1.2. Dirty headlamp

After being tested as specified in paragraph A4.1.1. above, the headlamp shall be operated for one hour as described in paragraph A4.1.1.1., after being prepared as prescribed in paragraph A4.1.2.1., and checked as prescribed in paragraph A4.1.1.2.

A4.1.2.1. Preparations of the headlamp

A4.1.2.1.1. Test mixture

A4.1.2.1.1.1. For headlamp with the outside lens in glass:

The mixture of water and a polluting agent to be applied to the headlamp shall be composed of:

9 parts by weight of silica sand with a particle size of 0-100 micrometers,

1 part by weight of vegetal carbon dust (beechwood) with a particle size of 0-100 micrometers,

0.2 parts by weight of NaCMC ⁽¹⁾, and

An appropriate quantity of distilled water, with a conductivity of < 1 mS/m.

The mixture must not be more than 14 days old.

A4.1.2.1.1.2. For headlamp with outside lens in plastic material:

The mixture of water and polluting agent to be applied to the headlamp shall be composed of:

9 parts by weight of silica sand with a particle size of 0-100 micrometers,

(1) NaCMC represents the sodium salt of carboxymethylcellulose, customarily referred to as CMC. The NaCMC used in the dirt mixture shall have a degree of substitution (DS) of 0.6-0.7 and a viscosity of 200-300 cP for a 2 per cent solution at 20 degrees C.

1 part by weight of vegetal carbon dust (beech wood) with a particle size of 0-100 micrometers,

0.2 part by weight of NaCMC ⁽¹⁾

13 parts by weight of distilled water with a conductivity of < 1 mS/m, and 2 ± 1 parts by weight of surface-actant ⁽²⁾

The mixture must not be more than 14 days old.

A4.1.2.1.2. Application of the test mixture to the headlamp

The test mixture shall be uniformly applied to the entire light-emitting surface of the headlamp and then left to dry. This procedure shall be repeated until the illumination value has dropped to 15-20 per cent of the values measured for each following point under the conditions described in this annex:

Point of Emax in dipped-beam/main-beam and in main-beam only, 50 L and 50 V ⁽³⁾ for a passing lamp only

A4.1.2.1.3. Measuring equipment

The measuring equipment shall be equivalent to that used during headlamp approval tests. A standard (etalon) filament lamp shall be used for the photometric verification.

A4.2. TEST FOR CHANGE IN VERTICAL POSITION OF THE CUT-OFF LINE UNDER THE INFLUENCE OF HEAT

This test consists of verifying that the vertical drift of the cut-off line under the influence of heat does not exceed a specified value for an operating passing lamp. The headlamp tested in accordance with paragraph A4.1, shall be subjected to the test described in paragraph A4.2.1., without being removed from or readjusted in relation to its test fixture.

A4.2.1. Test

The test shall be carried out in a dry and still atmosphere at an ambient temperature of $23^{\circ}\text{C} \pm 5^{\circ}\text{C}$.

(1) See foot note (1) on page no 23

(2) The tolerance on quantity is due to the necessity of obtaining a dirt that correctly spreads out on all the plastic lens.

(3) Point 50 V is situated 375 mm below HV on the vertical line v-v on the screen at 25 m distance.

Using a mass production filament lamp, which has been aged for at least one hour the headlamp shall be operated on dipped-beam without being dismantled from or readjusted in relation to its test fixture. (For the purpose of this test, the voltage shall be adjusted as specified in paragraph A4.1.1.1.2.). The position of the cut-off line in its horizontal part (between vv and the vertical line passing through point B 50 R) shall be verified 3 minutes (r3) and 60 minutes (r60) respectively after operation.

The measurement of the variation in the cut-off line position as described above shall be carried out by any method giving acceptable accuracy and reproducible results.

A4.2.2. Test results

A4.2.2.1 The result in milliradians (mrad) shall be considered as acceptable for a passing lamp, only when the absolute value $\Delta rI = | r3 - r60 |$ recorded on the headlamp is not more than 1.0 mrad ($\Delta rI < 1.0 \text{ mrad}$).

A4.2.2.2 However, if this value is more than 1.0 mrad but not more than 1.5 mrad ($1.0 \text{ mrad} < \Delta rI < 1.5 \text{ mrad}$) a second headlamp shall be tested as described in paragraph A4.2.1 after being subjected three consecutive times to the cycle as described below, in order to stabilize the position of mechanical parts of the headlamp on a base representative of the correct installation on the vehicle:

Operation of the dipped-beam for one hour, (the voltage shall be adjusted as specified in paragraph A4.1.1.1.2.),

Period of rest for one hour.

The headlamp type shall be considered as acceptable if the mean value of the absolute values ΔrI measured on the first sample and ΔrII measured on the second sample is not more than 1.0 mrad.

$$\left(\frac{\Delta r_1 + \Delta r_{11}}{2} \leq 1.0 \text{ mrad} \right)$$

ANNEX : A5
(See para A1.1.8)

**REQUIREMENTS FOR LAMPS INCORPORATING
LENSES OF PLASTIC MATERIAL-TESTING OF LENS OR
MATERIAL SAMPLES AND OF COMPLETE LAMPS**

A5.1. GENERAL SPECIFICATIONS

A5.1.1 The samples supplied pursuant to paragraph 7.3 of this standard shall satisfy the specifications indicated in paragraphs A5.2.1. to A5.2.5. below.

A5.1.2 The two samples of complete lamps supplied pursuant to paragraph 7.1 of this standard and incorporating lenses of plastic material shall, with regard to the lens material, satisfy the specifications indicated in paragraph A5.2.6 below.

A5.1.3. The samples of lenses of plastic material or samples of material shall be subjected, with the reflector to which they are intended to be fitted (where applicable), to approval tests in the chronological order indicated in Table A reproduced in Appendix-1 to this Annex: A5

A5.1.4. However, if the lamp manufacturer can prove that the product has already passed the tests prescribed in paragraphs A5.2.1.to A5.2.5. below, or the equivalent tests pursuant to another standard those tests need not be repeated; only the tests prescribed in Appendix 1, Table B, shall be mandatory.

A5.2. TESTS

A5.2.1. Resistance to Temperature Changes

A5.2.1.1 Tests

Three new samples (lenses) shall be subjected to five cycles of temperature and humidity (RH = relative humidity) change in accordance with the following programme.

3 hours at $40^{\circ}\text{C} \pm 2^{\circ}\text{C}$ and 85-95 % RH;

1 hour at $23^{\circ}\text{C} \pm 5^{\circ}\text{C}$ and 60-75 % RH;

15 hours at $-30^{\circ}\text{C} \pm 2^{\circ}\text{C}$;

1 hour at $23^{\circ}\text{C} \pm 5^{\circ}\text{C}$ and 60-75 % RH;

3 hours at $80^{\circ}\text{C} \pm 2^{\circ}\text{C}$;

1 hour at $23^{\circ}\text{C} \pm 5^{\circ}\text{C}$ and 60-75 % RH;

Before this test, the samples shall be kept at $23^{\circ}\text{C} \pm 5^{\circ}\text{C}$ and 60-75 % RH for at least four hours.

Note:

The periods of one hour at $23^{\circ}\text{C} \pm 5^{\circ}\text{C}$ shall include the periods of transition from one temperature to another, which are needed in order to avoid thermal shock effects.

A5.2.1.2. Photometric Measurements

A5.2.1.2.1. Method

Photometric measurements shall be carried out on the samples before and after the test. These measurements shall be made using a standard lamp, at the following points:

B 50 R and 50 L for the dipped-beam of a passing lamp or a passing/driving lamp

A5.2.1.2.2. Results

The variation between the photometric values measured on each sample before and after the test shall not exceed 10 % including the tolerances of the photometric procedure.

A5.2.2. Resistance to Atmospheric and Chemical Agents

A5.2.2.1. Resistance to Atmospheric Agents

Three new samples (lenses or samples of material) shall be exposed to radiation from a source having a spectral energy distribution similar to that of a black body at a temperature between 5,500K and 6,000K. Appropriate filters shall be placed between the source and the samples so as to reduce as far as possible radiations with wavelengths smaller than 295 nm and greater than 2,500 nm.

The samples shall be exposed to an energetic illumination of $1,200 \text{ W/m}^2 \pm 200 \text{ W/m}^2$ for a period such that the luminous energy that they receive is equal to $4,500 \text{ MJ/m}^2 \pm 200 \text{ MJ/m}^2$. Within the enclosure, the temperature measured on the black panel placed on a level with the samples shall be $50^{\circ} \text{ C} \pm 5^{\circ} \text{ C}$. In order to ensure a regular exposure, the samples shall revolve around the source of radiation at a speed between 1 and 5 l/min.

The samples shall be sprayed with distilled water of conductivity lower than 1 mS/m at a temperature of $23^{\circ} \text{ C} \pm 5^{\circ} \text{ C}$, in accordance with the following cycle:

spraying: 5 minutes;
drying: 25 minutes.

A5.2.2.2. Resistance to Chemical Agents

After the test described in paragraph A5.2.2.1. above and the measurement described in paragraph A5.2.2.3.1. below have been carried out, the outer face of the said three samples shall be treated as described in paragraph A5.2.2.2.2. with the mixture defined in paragraph A5.2.2.2.1 below.

A5.2.2.2.1 Test mixture

The test mixture shall be composed of 61.5 % n-heptane, 12.5 % toluene, 7.5 % ethyl tetrachloride, 12.5 % trichlorethylene and 6 % xylene (volume %).

A5.2.2.2.2. Application of the test mixture

Soak a piece of cotton cloth (as per ISO 105) until saturation with the mixture defined in paragraph A5.2.2.2.1 above and, within 10 seconds, apply it for 10 minutes to the outer face of the sample at a pressure of 50 N/cm², corresponding to an effort of 100 N applied on a test surface of 14 x 14 mm.

During this 10-minute period, the cloth pad shall be soaked again with the mixture so that the composition of the liquid applied is continuously identical with that of the test mixture prescribed.

During the period of application, it is permissible to compensate the pressure applied to the sample in order to prevent it from causing cracks.

A5.2.2.2.3. Cleaning

At the end of the application of the test mixture, the samples shall be dried in the open air and then washed with the solution described in paragraph A5.2.3. (Resistance to detergents) at 23°C ± 5°C.

Afterwards the samples shall be carefully rinsed with distilled water containing not more than 0.2 % impurities at 23°C ± 5°C and then wiped off with a soft cloth.

A5.2.2.3. **Results**

A5.2.2.3.1 After the test of resistance to atmospheric agents, the outer face of the samples shall be free from cracks, scratches, chipping and deformation, and the mean variation in transmission

$$\Delta t = \frac{T2 - T3}{T2}$$

measured on the three samples according to the procedure described in Appendix 2 to this Annex shall not exceed 0.020 (delta tm < 0.020).

A5.2.2.3.2 After the test of resistance to chemical agents, the samples shall not bear any traces of chemical staining likely to cause a variation of flux diffusion, whose mean variation

$$\Delta d = \frac{T5 - T4}{T2}$$

measured on the three samples according to the procedure described in Appendix 2 to this Annex shall not exceed 0.020 (Delta tm < 0.020).

A5.2.3. **Resistance to Detergents and Hydrocarbons**A5.2.3.1. **Resistance to Detergents**

The outer face of three samples (lenses or samples of material) shall be heated to 50 degrees C \pm 5°C and then immersed for five minutes in a mixture maintained at 23°C \pm 5°C and composed of 99 parts distilled water containing not more than 0.02 % impurities and one part alkylaryl sulphonate. At the end of the test, the samples shall be dried at 50°C \pm 5°C . The surface of the samples shall be cleaned with a moist cloth.

A5.2.3.2. **Resistance to Hydrocarbons**

The outer face of these three samples shall then be lightly rubbed for one minute with a cotton cloth soaked in a mixture composed of 70% n-heptane and 30%toluene (volume %), and shall then be dried in the open air.

A5.2.3.3. **Results**

After the above two tests have been performed successively, the mean value of the variation in transmission

$$\Delta t = \frac{T2 - T3}{T2}$$

measured on the three samples according to the procedure described in Appendix 2 to this Annex shall not exceed 0.010 ($\Delta t_m < 0.010$).

A5.2.4 **Resistance to Mechanical Deterioration**

A5.2.4.1. **Mechanical Deterioration Method**

The outer face of the three new samples (lenses) shall be subjected to the uniform mechanical deterioration test by the method described in Appendix 3 to this Annex.

A5.2.4.2. **Results**

After this test, the variations:
in transmission:

$$\Delta t = \frac{T2 - T3}{T2}$$

and in diffusion:

$$\Delta d = \frac{T5 - T4}{T2}$$

shall be measured according to the procedure described in Appendix 2 in the area specified in paragraph A5.2.2.4.1.1 above. The mean value of the three samples shall be such that: $\Delta t_m < 0.100$; $\Delta d_m < 0.050$.

A5.2.5 **Test of Adherence of Coatings, if any**

A5.2.5.1. **Preparation of the sample**

A surface of 20 mm x 20 mm in area of the coating of a lens shall be cut with a razor blade or a needle into a grid of squares approximately 2 mm x 2 mm. The pressure on the blade or needle shall be sufficient to cut at least the coating.

A5.2.5.2. **Description of the Test**

Use an adhesive tape with a force of adhesion of 2 N/(cm of width) \pm 20 % measured under the standardized conditions specified in Appendix 4 to this annex. This adhesive tape, which shall be at least 25 mm wide, shall be pressed for at least five minutes to the surface prepared as prescribed in paragraph A5.2.5.1.

Then the end of the adhesive tape shall be loaded in such a way that the force of adhesion to the surface considered is balanced by a force perpendicular to that surface. At this stage, the tape shall be torn off at a constant speed of 1.5 m/s \pm 0.2 m/s.

A5.2.5.3. **Results**

There shall be no appreciable impairment of the gridded area. Impairments at the intersections between squares or at the edges of the cuts shall be permitted, provided that the impaired area does not exceed 15 % of the gridded surface.

A5.2.6 **Tests of the Complete Lamp Incorporating a Lens of Plastic Material**

A5.2.6.1. **Resistance to Mechanical Deterioration of the Lens Surface**

A5.2.6.1.1. **Tests**

The lens of lamp sample No. 1 shall be subjected to the test described in paragraph A5.2.4.1.above.

A5.2.6.1.2. **Results**

After the test, the results of photometric measurements carried out on the lamp in accordance with this Regulation shall not exceed by more than 30 % the maximum values prescribed at points B 50 R and HV and not be more than 10 per cent below the minimum values prescribed at point 75 L.

A5.2.6.2. **Test of Adherence of Coatings, if any**

The lens of lamp sample No. 2 shall be subjected to the test described in paragraph A5.2.5. above.

A5.3 VERIFICATION OF THE CONFORMITY OF PRODUCTION

A5.3.1. With regard to the materials used for the manufacture of lenses, the lamps of a series shall be recognized as complying with this Standard if:

AIS-012

- A5.3.1.1. After the test for resistance to chemical agents and the test for resistance to detergents and hydrocarbons, the outer face of the samples exhibits no cracks, chipping or deformation visible to the naked eye (see para. A5.2.2.2, A5.2.3.1. and A5.2.3.2.);
- A5.3.1.2. After the test described in paragraph A5.2.6.1.1 the photometric values at the points of measurement considered in paragraph A5.2.6.1.2. are within the limits prescribed for conformity of production by this standard.
- A5.3.2. If the test results fail to satisfy the requirements, the tests shall be repeated on another sample of headlamps selected at random.

ANNEX:A5 – APPENDIX:1

(See para A5.1.3)

CHRONOLOGICAL ORDER OF APPROVAL TESTS

Table A: Tests on plastic materials (lenses or samples of material supplied pursuant to paragraph 7.3 of this standard).

Samples Test		Lenses or samples of material					Lenses							
		1	2	3	4	5	6	7	8	9	10	11	12	13
A5:App1.1.1	Limited Photometry (Para.A5.2.1.2)										x	x	x	
A5:App1.1.1.1	Temperature change (para. A5.2.1.1.)										x	x	x	
A5:App1.1.1.2.	Limited photometry (para. A5.2.1.2.)										x	x	x	
A5:App1.1.2.1	Transmission Measurement	x	x	x	x	x	x	x	x	x				
A5:App1.1.2.2.	Diffusion measurement	x	x	x				x	x	x				
A5:App1.1.3.	Atmospheric agents (para. A5.2.2.1.)	x	x	x										
A5:App1.1.3.1.	Transmission Measurement	x	x	x										
A5:App1.1.4.	Chemical agents (para.A5.2.2.2.)	x	x	x										
A5:App1.1.4.1.	Diffusion Measurement	x	x	x										
A5:App1.1.5.	Detergents (para. A5.2.3.1.)				x	x	x							
A5:App1.1.6.	Hydrocarbons (para. A5.2.3.2.)				x	x	x							
A5:App1.1.6.1.	Transmission measurement				x	x	x							
A5:App1.1.7.	Deterioration (para. A5.2.4.1.)							x	x	x				
A5:App1.1.7.1.	Transmission Measurement							x	x	x				
A5:App1.1.7.2.	Diffusion Measurement							x	x	x				
A5:App1.1.8.	Adherence (para.A5.2.5.)													x

Table B: Tests on complete headlamps supplied pursuant to paragraph 7.1. of this standard).

Tests		Complete headlamp	
		Sample No.	
		1	2
A5:App1.2.1.	Deterioration (para. A5.2.6.1.1.)	x	
A5:App1.2.2.	Photometry (para. A5.2.6.1.2.)	x	
A5:App1.2.3.	Adherence (para. A5.2.6.2.)		X

-

ANNEX:A5 – APPENDIX:2

(See para A5.2.2.3.1)

**METHOD OF MEASUREMENT OF THE DIFFUSION
AND TRANSMISSION OF LIGHT**

A5:App2.1. Equipment (see figure in this Appendix)

The beam of a collimator K with a half divergence $\beta/2 = 17.4 \times 10^4$ rd is limited by a diaphragm D_τ with an opening of 6 mm against which the sample stand is placed.

A convergent achromatic lens L_2 , corrected for spherical aberrations links the diaphragm D_τ with the receiver R; the diameter of the lens L_2 shall be such that it does not diaphragm the light diffused by the sample in a cone with a half top angle of $\beta/2 = 14^\circ$.

An annular diaphragm D_D , with angles

“ $\alpha_o/2 = 1^\circ$ and $\alpha_{max}/2 = 12^\circ$ ”

is placed in an image focal plane of the lens L_2 .

The non-transparent central part of the diaphragm is necessary in order to eliminate the light arriving directly from the light source. It shall be possible to remove the central part of the diaphragm from the light beam in such a manner that it returns exactly to its original position.

The distance $L_2 D_\tau$ and the focal length $F_2^{(1)}$ of the lens L_2 shall be so chosen that the image of D_τ completely covers the receiver R.

When the initial incident flux is referred to 1,000 units, the absolute precision of each reading shall be better than 1 unit.

A5: App2.2. Measurements

The following readings shall be taken:

Reading	With sample	With central part of D_D	Quantity represented
T ₁	No	no	Incident flux in initial reading
T ₂	yes (before test)	no	Flux transmitted by the new material in a field of 24°
T ₃	yes (after test)	no	Flux transmitted by the tested material in a field of 24°
T ₄	yes (before test)	Yes	Flux diffused by the new material
T ₅	Yes (after test)	Yes	Flux diffused by the tested material

(1) For L_2 it is recommended to use a focal distance of about 80mm.

FIGURE

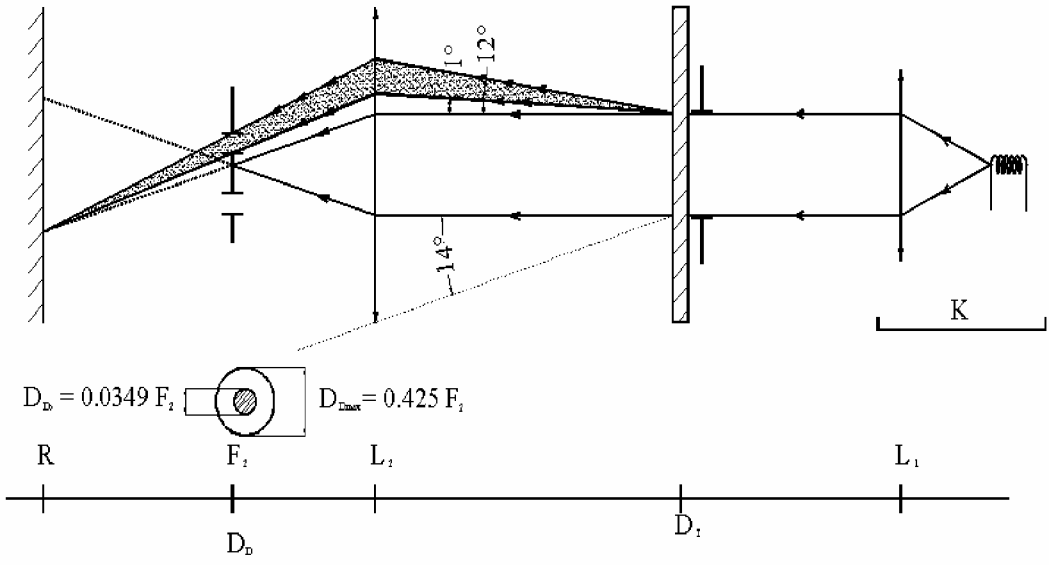

ANNEX:A5 – APPENDIX:3

(See para A5.2.4.1.)

SPRAY TESTING METHOD**A5:App3.1. TEST EQUIPMENT****A5:App3.1.1. Spray gun**

The spray gun used shall be equipped with a nozzle 1.3 mm in diameter allowing a liquid flow rate of 0.24 ± 0.02 l/minute at an operating pressure of 6.0 bars $-0/+0.5$ bar.

Under these operation conditions the fan pattern obtained shall be $170 \text{ mm} \pm 50 \text{ mm}$ in diameter on the surface exposed to deterioration, at a distance of $380 \text{ mm} \pm 10 \text{ mm}$ from the nozzle.

A5:App3.1.2. Test mixture

The test mixture shall be composed of:

Silica sand of hardness 7 on the Mohr scale, with a grain size between 0 and 0.2 mm and an almost normal distribution, with an angular factor of 1.8 to 2;

Water of hardness not exceeding 205 g/m^3 for a mixture comprising 25 g of sand per litre of water.

A5:App3.2. TEST

The outer surface of the lamp lenses shall be subjected once or more than once to the action of the sand jet produced as described above. The jet shall be sprayed almost perpendicular to the surface to be tested.

The deterioration shall be checked by means of one or more samples of glass placed as a reference near the lenses to be tested. The mixture shall be sprayed until the variation in the diffusion of light on the sample or samples measured by the method described in Appendix 2, is such that:

$$\Delta d = \frac{T_5 - T_4}{T_2} = 0.0250 \pm 0.0025$$

Several reference samples may be used to check that the whole surface to be tested has deteriorated homogeneously.

ANNEX: A5 – APPENDIX:4
(See para A5.2.5.2)

ADHESIVE TAPE ADHERENCE TEST

A5:App4.1. PURPOSE

This method allows to determine under standard conditions the linear force of adhesion of an adhesive tape to a glass plate.

A5:App4.2. PRINCIPLE

Measurement of the force necessary to unstuck an adhesive tape from a glass plate at an angle of 90⁰.

A5:App4.3. SPECIFIED ATMOSPHERIC CONDITIONS

The ambient conditions shall be at 23⁰ C ± 5⁰ C and 65 ± 15 % RH.

A5:App4.4. TEST PIECES

Before the test, the sample roll of adhesive tape shall be conditioned for 24 hours in the specified atmosphere (see para. A5:App.4.3 above).

Five test pieces each 400 mm long shall be tested from each roll. These test pieces shall be taken from the roll after the first three turns were discarded.

A5:App4.5. PROCEDURE

The test shall be under the ambient conditions specified in paragraph A5:App.4.3.

Take the five test pieces while unrolling the tape radially at a speed of approximately 300 mm/s, then apply them within 15 seconds in the following manner:

Apply the tape to the glass plate progressively with a slight length- wise rubbing movement of the finger, without excessive pressure, in such a manner as to leave no air bubble between the tape and the glass plate.

Leave the assembly in the specified atmospheric conditions for 10 minutes.

Unstuck about 25 mm of the test piece from the plate in a plane perpendicular to the axis of the test piece.

AIS-012

Fix the plate and fold back the free end of the tape at 90° . Apply force in such a manner that the separation line between the tape and the plate is perpendicular to this force and perpendicular to the plate.

Pull to unstuck at a speed of $300 \text{ mm/s} \pm 30 \text{ mm/s}$ and record the force required.

A5:App4.6.

RESULTS

The five values obtained shall be arranged in order and the median value taken as a result of the measurement. This value shall be expressed in Newtons per centimetre of width of the tape.

ANNEX: A6
(See para 8.0)

**MINIMUM REQUIREMENTS FOR CONFORMITY OF
PRODUCTION CONTROL PROCEDURES**

A6.1. GENERAL

A6.1.1 The conformity requirements shall be considered satisfied from a mechanical and a geometrical standpoint, if the differences do not exceed inevitable manufacturing deviations within the requirements of this Standard. This condition also applies to colour.

A6.1.2. With respect to photometric performances, the conformity of mass-produced headlamps shall not be contested if, when testing photometric performances of any headlamp chosen at random and equipped with a standard (étalon) filament lamp:

A6.1.2.1. No measured value deviates unfavourably by more than 20 per cent from the value prescribed in this standard. For values B 50 R and zone III, the maximum unfavourable deviation may be respectively:

B 50 R	0.2 lx equivalent 20%
	0.3 lx equivalent 30 %
Zone III	0.3 lx equivalent 20 %
	0.45 lx equivalent 30 %

A6.1.2.2. or if

A6.1.2.2.1. For the dipped-beam, the values prescribed in this standard are met at HV (with a tolerance of + 0.2 lx) and related to that aiming at least one point of each area delimited on the measuring screen (at 25 m) by a circle 15 cm in radius around points B 50 R (with a tolerance of + 0.1 lx), 75 L, 50 V, 25 R, 25 L, and in the entire area of zone IV which is not more than 22.5 cm above line 25 R and 25 L;

A6.1.2.2.2. And if, for the main-beam, HV being situated within the isolux $0.75 E_{\max}$, a tolerance of + 20 per cent for maximum values and -20 per cent for minimum values is observed for the photometric values at any measuring point specified in paragraph A2.3.2. of this standard.

AIS-012

- A6.1.2.3. If the results of the test described above do not meet the requirements, the alignment of the headlamp may be changed, provided that the axis of the beam is not displaced laterally by more than 1^0 to the right or left⁽¹⁾
- A6.1.2.4. If the results of the tests described above do not meet the requirements, tests shall be repeated using another standard (étalon) filament lamp.
- A6.1.3. With respect to the verification of the change in vertical position of the cut-off line under the influence of heat, the following procedure shall be applied:

One of the sampled headlamps shall be tested according to the procedure described in paragraph A4.2.1. of Annex A4 after being subjected three consecutive times to the cycle described in paragraph A4.2.2.2. of Annex : A4

The headlamp shall be considered as acceptable if Δr does not exceed 1.5 mrad.

If this value exceeds 1.5 mrad but is not more than 2.0 mrad, a second sample shall be subjected to the test after which the mean of the absolute values recorded on both samples shall not exceed 1.5 mrad.

A6.2. MINIMUM REQUIREMENTS FOR VERIFICATION OF CONFORMITY BY THE MANUFACTURER

For each type of headlamp the holder of the approval mark shall carry out at least the following tests, at appropriate intervals. The tests shall be carried out in accordance with the provision of this standard.

If any sampling shows non-conformity with regard to the type of test concerned, further samples shall be taken and tested. The manufacturer shall take steps to ensure the conformity of the production concerned.

A6.2.1. Nature of Tests

Tests of conformity in this standard shall cover the photometric characteristics and the verification of the change in vertical position of the cut-off line under the influence of heat.

(1) The limit of realignment of 1^0 towards the right or left is not incompatible with upward or down ward vertical realignment. The latter is limited only by the requirements of paragraph A2.3 However, the horizontal part of the "cut-off" should not extend beyond the line hh (the provisions of paragraph A2.3 are not applicable to headlamps intended to meet the requirements of relevant Annexes only for provision of a dipped-beam).

A6.2.2. **Methods used in tests**

A6.2.2.1. Tests shall generally be carried out in accordance with the methods set out in this standard

A6.2.2.2. In any test of conformity carried out by the manufacturer, equivalent methods may be used with the consent of the test agency responsible for approval tests. The manufacturer is responsible for proving that the applied methods are equivalent to those laid down in this Standard.

A6.2.2.3. The application of paragraphs A6.2.2.1. and A6.2.2.2. requires regular calibration of test apparatus and its correlation with measurement made by a test agency.

A6.2.2.4. In all cases the reference methods shall be those of this Standard, particular for the purpose of administrative verification and sampling.

A6.2.3. **Nature of Sampling**

Samples of headlamps shall be selected at random from the production of a uniform batch. A uniform batch means a set of headlamps of the same type, defined according to the production methods of the manufacturer.

The assessment shall, in general, cover series production from individual factories. However, a manufacturer may group together records concerning the same type from several factories provided these operate under the same quality system and quality management.

A.6.2.4. **Measured and Recorded Photometric Characteristics**

The sampled headlamps shall be subjected to photometric measurements at the points provided for in the Standard, the reading being limited at the points E_{\max} , $HV^{(1)}$ HL, $HR^{(2)}$ in the case of a main-beam, and to points B 50 R, HV, 50 V, 75 L and 25 R in the case of the dipped-beam (see Figure A1).

(1) When the main-beam is reciprocally incorporated with the dipped-beam, HV in the case of the main-beam shall be the same measuring point as in the case of the dipped-beam

(2) HL and HR: points "hh" located at 1.125 m to the left and to the right of point HV respectively)

A6.2.5. Criteria Governing Acceptability

The manufacturer is responsible for carrying out a statistical study of the test results and for defining, in agreement with the test agency, criteria governing acceptability of his products in order to meet the specification laid down for verification of conformity of products in paragraph 8.1 of this standard.

The criteria governing acceptability shall be such that, with a confidence level of 95 per cent, the minimum probability of passing a spot check in accordance with Annex: A7 (first sampling) would be 0.95.

ANNEX: A7
(See para 8.0 and para A6.2.5)

**MINIMUM REQUIREMENTS FOR SAMPLING BY
AN INSPECTOR**

A7.1. GENERAL

A7.1.1. The conformity requirements shall be considered satisfied from a mechanical and a geometrical standpoint in accordance with the requirements of this Standard, if any, if the differences do not exceed inevitable manufacturing deviations. This condition also applies to colour.

A7.1.2. With respect to photometric performances, the conformity of mass-produced headlamps shall not be contested if, when testing photometric performances of any headlamp chosen at random and equipped with a standard filament lamp:

A7.1.2.1. No measured value deviates unfavourably by more than 20 per cent from the value prescribed in this Standard. For values B 50 R and zone III, the maximum unfavourable deviation may be respectively:

B 50 R	:	0.2 lx equivalent 20 %
		0.3 lx equivalent 30 %
Zone III	:	0.3 lx equivalent 20 %
		0.45 lx equivalent 30 %

A7.1.2.2. or if

A7.1.2.2.1. for the dipped-beam, the values prescribed in this standard are met at HV (with a tolerance of 0.2 lx) and related to that aiming at least one point of each area delimited on the measuring screen (at 25 m) by a circle 15 cm in radius around points B 50 R (with a tolerance of 0.1 lx), 75 L, 50 V, 25 R, 25 L, and in the entire area of zone IV which is not more than 22.5 cm above line 25 R and 25 L;

A7.1.2.2.2. and if, for the main-beam, HV being situated within the isolux $0.75 E_{max}$, a tolerance of + 20 per cent for maximum values and - 20 per cent for minimum values is observed for the photometric values at any measuring point specified in paragraph A 2.3.2 of Annex: A2. The reference mark is disregarded.

- A7.1.2.3. If the results of the test described above do not meet the requirements, the alignment of the headlamp may be changed, provided that the axis of the beam is not displaced laterally by more than 1° to the right or left⁽¹⁾.
- A7.1.2.4. If the results of the tests described above do not meet the requirements, tests shall be repeated using another standard filament lamp.
- A7.1.2.5. Headlamps with apparent defects are disregarded.
- A7.1.2.6. The reference mark is disregarded.

A7.2. FIRST SAMPLING

In the first sampling four headlamps are selected at random. The first sample of two is marked A, the second sample of two is marked B.

A7.2.1. The Conformity is Not Contested

A7.2.1.1. Following the sampling procedure shown in Figure A3 the conformity of mass-produced headlamps shall not be contested if the deviations of the measured values of the headlamps in the unfavourable directions are:

A7.2.1.1.1. Sample A

A1:	one headlamp		0 %
	one headlamp	not more than	20%
A2:	both headlamps	more than	0 %
	But	not more than	20%
	go to sample B		

A7.2.1.1.2. Sample B

B1:	Both headlamps		0 %
-----	----------------	--	-----

A7.2.1.2. or if the conditions of paragraph A7.1.2.2. for sample A are fulfilled.

(1) The limit of realignment of 1° towards the right or left is not incompatible with upward or down ward vertical realignment. The latter is limited only by the requirements of paragraph A2.3 However, the horizontal part of the “cut-off” should not extend beyond the line hh (the provisions of paragraph A2.3 are not applicable to headlamps intended to meet the requirements of relevant Annexes only for provision of a dipped-beam).

A7.2.2. The Conformity is Contested

A7.2.2.1. Following the sampling procedure shown in Figure A3 the conformity of mass-produced headlamps shall be contested and the manufacturer requested to make his production meet the requirements (alignment) if the deviations of the measured values of the headlamps are:

A7.2.2.1.1. **Sample A**

A3:	one headlamp	not more than	20%
	one headlamp	more than	20%
	but	not more than	30%

A7.2.2.1.2. **Sample B**

B2:	in the case of A2		
	one headlamp	more than	0%
	But	not more than	20%
	one headlamp	not more than	20%
B3:	in the case of A2		
	one headlamp		0%
	one headlamp	more than	20%
	but	not more than	30%

A7.2.2.2. or if the conditions of paragraph A7.1.2.2. for sample A are not fulfilled.

A7.2.3. **Approval Withdrawn**

Conformity shall be contested and paragraph 8.3 of this standard applied if, following the sampling procedure shown in Figure 1 of this annex, the deviations of the measured values of the headlamps are:

A7.2.3.1. **Sample A**

A4:	one headlamp	not more than	20%
	one headlamp	more than	30%
A5:	Both headlamps	more than	20%

A7.2.3.2. **Sample B**

B4:	in the case of A2		
	one headlamp	more than	0%
	but	not more than	20%
	one headlamp	more than	20%
B5:	in the case of A2		
	both headlamps	more than	20%
B6:	in the case of A2		
	one headlamp		0%
	one headlamp	more than	30%

A7.2.3.3. or if the conditions of paragraph A7.1.2.2. for samples A and B are not fulfilled.

A7.3. REPEATED SAMPLING

In the case of A3, B2, B3 a repeated sampling, third sample C of two headlamps and fourth sample D of two headlamps, selected from stock manufactured after alignment, is necessary within two months' time after the notification.

A7.3.1. The Conformity is Not Contested

A7.3.1.1. Following the sampling procedure shown in FigureA3, the conformity of mass-produced headlamps shall not be contested if the deviations of the measured values of the headlamps are:

A7.3.1.1.1. Sample C

C1:	one headlamp		0%
	one headlamp	not more than	20%
C2:	both headlamps	more than	0%
	But	not more than	20%
	go to sample D		

A7.3.1.1.2. Sample D

D1:	In the case of C2		
	both headlamps		0%

A7.3.1.2. or if the conditions of paragraph A7.1.2.2. for sample C are fulfilled.

A7.3.2. The Conformity is Contested

A7.3.2.1. Following the sampling procedure shown in Figure A3, the conformity of mass-produced headlamps shall be contested and the manufacturer requested to make his production meet the requirements (alignment) if the deviations of the measured values of the headlamps are:

A7.3.2.1.1. Sample D

D2:	In the case of C2		
	one headlamp	more than	0%
	But	not more than	20%
	one headlamp	not more than	20%

A7.3.2.1.2. or if the conditions of paragraph A7.1.2.2 for sample C are not fulfilled.

A7.3.3. Approval Withdrawn

Conformity shall be contested and paragraph 8.3 of this standard applied if, following the sampling procedure shown in Figure A3, the deviations of the measured values of the headlamps are:

A7.3.3.1. Sample C

C3:	one headlamp	not more than	20%
	one headlamp	more than	20%
C4:	both headlamps	more than	20%

A7.3.3.2. Sample D

D3:	in the case of C2		
	one headlamp	0 or more than	0%
	one headlamp	more than	20%

A7.3.3.3. or if the conditions of paragraph A7.1.2.2. for samples C and D are not fulfilled.

A7.4. CHANGE OF THE VERTICAL POSITION OF THE CUT-OFF LINE

With respect to the verification of the change in vertical position of the cut-off line under the influence of heat, the following procedure shall be applied:

One of the headlamps of sample A after sampling procedure in Figure A3 shall be tested according to the procedure described in paragraph A4.2.1. of Annex : A4 after being subjected three consecutive times to the cycle described in paragraph A4.2.2.2. of Annex A4.

The headlamp shall be considered as acceptable if Δr does not exceed 1.5 mrad.

If this value exceeds 1.5 mrad but is not more than 2.0 mrad, the second headlamp of sample A shall be subjected to the test after which the mean of the absolute values recorded on both samples shall not exceed 1.5 mrad.

However, if this value of 1.5 mrad on sample A is not complied with, the two headlamps of sample B shall be subjected to the same procedure and the value of Δr for each of them shall not exceed 1.5 mrad.

ANNEX : A8

**OVERVIEW OF OPERATIONAL PERIODS CONCERNING
TEST FOR STABILITY OF PHOTOMETRIC PERFORMANCE**

- Abbreviations:**
- P: dipped-beam lamp
 - D: main-beam lamp (D₁ + D₂ means two main-beams)
 - F: front fog lamp
 - - - - - : means a cycle of 15 minutes off and 5 minutes lit.

All following grouped headlamps and front fog lamps together with the added class B marking symbols are given as examples and are not exhaustive.

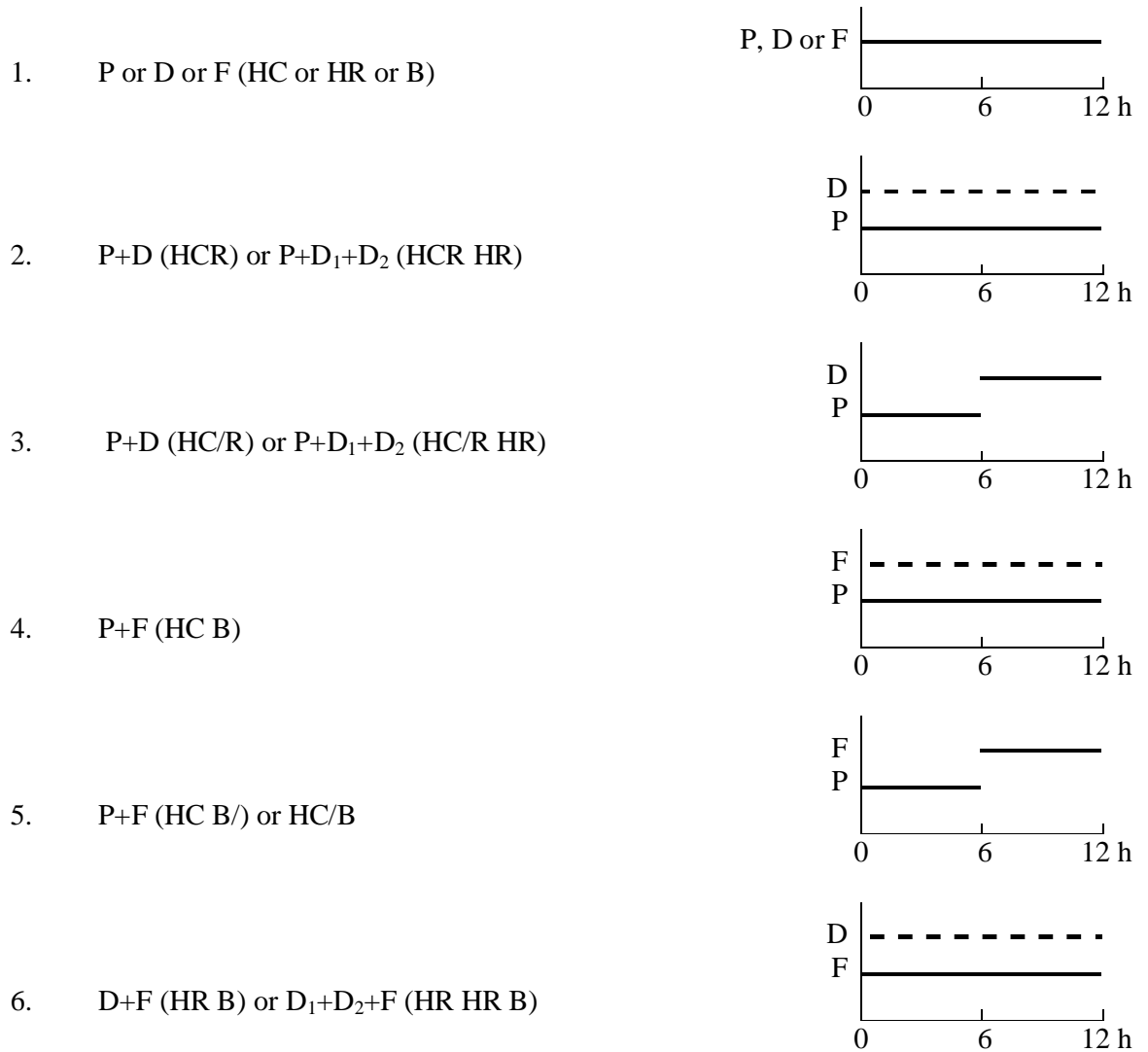

7. D+F (HR B/) or D₁+D₂+F (HR HR B/)

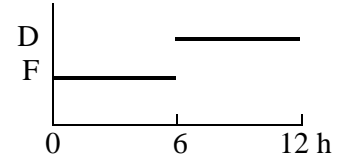

8. P+D+F (HCR B) or P+D₁+D₂+F (HCR HR B)

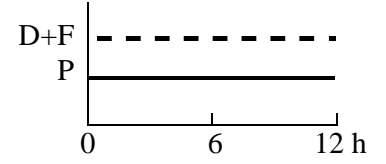

9. P+D+F (HC/R B) or P+D₁+D₂+F (HC/R HR B)

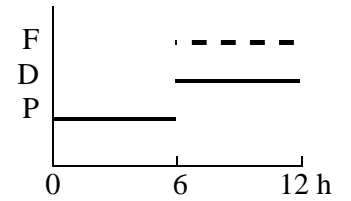

10. P+D+F (HCR B/) or P+D₁+D₂+F (HCR HR B/)

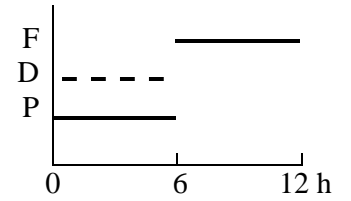

11. P+D+F (HC/R B/) or P+D₁+D₂+F (HC/R HR B/)

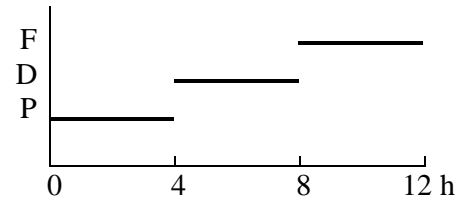

ANNEX : B1

(See para 5.2)

**REQUIREMENTS FOR HEADLAMP EQUIPED WITH
GAS-DISCHARGE LIGHT SOURCES****B1.1. GENERAL REQUIREMENTS**

B1.1.1. Each sample shall conform to the specifications set forth in Annex B1,B2, B3 and Annex L

B1.1.2. Headlamps shall be so made as to retain their prescribed photometric characteristics and to remain in good working order when in normal use, in spite of the vibrations to which they may be subjected.

B1.1.2.1. Headlamps shall be fitted with a device enabling them to be so adjusted on the vehicles as to comply with the rules applicable to them. Such a device need not be fitted on units in which the reflector and the diffusing lens cannot be separated, provided the use of such units is confined to vehicles on which the headlamp setting can be adjusted by other means.

Where a headlamp providing a dipped-beam and a headlamp providing a main-beam, each equipped with its own filament lamp, are assembled to form a composite unit the adjusting device shall enable each optical system individually to be duly adjusted. The same provision applies to headlamps providing a dipped-beam and a front fog lamp beam, and to headlamps providing these three beams.

B1.1.2.2. However, these provisions shall not apply to headlamp assemblies whose reflectors are indivisible. For this type of assembly the requirements of paragraph B2.3 of this standard shall apply.

B1.1.3 In the case when gas-discharge light source replacement can be carried out without tools, the lamp holder shall conform to the dimensional characteristics as given on the data sheet of AIS 034, relevant to the category of gas-discharge light source used. The gas-discharge light source must fit easily into the headlamp.

B1.1.4 Headlamp designed shall satisfy the requirements of left-hand traffic.

B1.1.5 On headlamps designed to provide alternately a main-beam and a dipped-beam, any mechanical, electromechanical or other device incorporated in the headlamp for switching from one beam to other⁽¹⁾ shall be so constructed that:

(1) These provisions shall not apply to the control switch

- B1.1.5.1 The device is strong enough to withstand 50,000 operations without suffering damage despite the vibrations to which it may be subjected in normal use.
- B1.1.5.2 In the case of failure it is possible to obtain the dipped-beam automatically.
- B1.1.5.3 Either the dipped-beam or the main-beam shall always be obtained without any possibility of the mechanism stopping in between two positions;
- B1.1.5.4. The user cannot, with ordinary tools, change the shape or position of the moving parts.
- B1.1.6. Complementary test shall be done according to Annex : B4 to ensure that in use there is no excessive change in photometric performance.
- B1.1.7. Light transmitting components made of plastic material shall be tested according to the requirements of Annex : B5
- B1.1.8. The headlamp and ballast system shall not generate radiated or power line disturbances to cause a malfunction of other electric / electronic system of the vehicle ⁽¹⁾

(1) Compliance with the requirements for electromagnetic compatibility is relevant to the individual vehicle type.

ANNEX : B2

(See para 5.2 and B1.1.1)

**PHOTOMETRIC TEST PROCEDURE AND
ILLUMINATION REQUIREMENTS FOR HEADLAMP
EQUIPED WITH GAS-DISCHARGE LIGHT SOURCES****B2.1 GENERAL PROVISIONS**

B2.1.1 Headlamps shall be so made that with suitable gas-discharge light source they give adequate illuminance without dazzle when emitting the dipped-beam, and good illumination when emitting the main-beam.

B2.1.2 The illumination produced by the headlamp shall be determined by means of a vertical screen set up 25 m forward of the headlamp and at right angles to its axes (see paragraph B2.2.6. and Figure B1 and B2), or by any equivalent photometric method.

B2.1.3 The headlamp using a removable gas-discharge light source shall be deemed satisfactory if the photometric requirements set in the present Annex : B2 are met with one standard light source, which has been aged during at least 15 cycles, in accordance with paragraph 9.2.1.2 of AIS-034. The flux of this gas-discharge light source may differ from the objective luminous flux specified in AIS 034. In this case, the illuminances shall be corrected accordingly.

This correction does not apply to headlamps using non-removable gas-discharge light source, or to headlamps with the ballast(s) totally or partially integrated.

B2.1.4 The dimensions determining the position of the arc inside the standard gas-discharge light source are shown in the relevant data sheet of standard AIS 034.

B2.1.5 Photometric compliance must be checked in accordance with paragraph B2.2.6 or B2.3 of this Annex. This is also valid for the cut-off zone between 3° R and 3° L (measurement method for the cut-off colour being under consideration).

B2.1.6 Four seconds after ignition of a headlamp which has not been operated for 30 minutes or more, 60 lux at least must be reached at point HV of a main-beam and 10 lux at point 50V of a dipped-beam for headlamps incorporating main-beam and dipped-beam functions, or 10 lux at point 50V for headlamps having only a dipped-beam function. The power supply shall be sufficient to secure the quick rise of the high current pulse.

B2.2. PROVISIONS CONCERNING DIPPED-BEAM

B2.2.1 The dipped-beam must produce a sufficiently sharp "cut-off" to permit a satisfactory adjustment with its aid. The "cut-off" must be a horizontal straight line on the side opposite to the direction of traffic for which the headlamp is intended; on the other side it must not extend either above the line HV/H2 of Figure B1, or above the line HV/H3/H4 of Figure B2. A cut-off extending above a combination of these lines shall in no circumstances be permitted.

B2.2.2 The headlamp shall be so aimed that:

B2.2.2.1 In the case of headlamps designed to meet the requirements of left-hand traffic, the "cut-off" on the right-half of the screen is horizontal ⁽¹⁾

B2.2.2.2 This horizontal part of the "cut-off" is situated on the screen 25 cm below the line HH. (See Figure B1, B2) The kink of the elbow of the cut-off shall be on the VV line.

B2.2.3 When so aimed, the headlamp needs, if its approval is sought solely for a dipped-beam, comply only with the requirements referred to in paragraphs B2.2.5 and B2.2.6 below; if it is intended to provide both a dipped-beam and a main-beam, it shall comply with the requirements set out in paragraphs B2.2.5 to B2.3.2.3. The values specified for segment II in paragraph B2.2.6 do not apply to Figure B2.

B2.2.4 Where a headlamp so aimed does not meet the requirements set out in paragraphs B2.2.6 and B2.3., its alignment may be changed, provided that the axis of the beam is not displaced laterally by more than 0.5° (=22 cm) ⁽²⁾ to the right or left and vertically not more than 0.2° (=8.7 cm) up or down. To facilitate alignment by means of the "cut-off", the headlamp may be partially occulted in order to sharpen the "cut-off".

B2.2.5 Only one gas-discharge light source is permitted for each dipped-beam headlamp.

B2.2.5.1 The voltage applied to the terminals of the ballast(s) is:
either: 13.5 V +/- 0.1 for 12 V systems
or: otherwise specified (See Annex : B9)

(1) The test screen must be sufficiently wide to allow examination of the "cut-off" over a range of at least 5° each side of the line VV.

(2) The limit of realignment of 0.5° towards the right or left is not incompatible with upward or downward vertical realignment. The latter is limited, too, by the requirements of para. B2.3. However, the provisions of paragraph B2.3 are not applicable to headlamps intended to meet the requirements of this Annex only for provision of dipped-beam

B2.2.6 After more than 10 minutes after ignition the illuminances produced on Screen of Figure B1 or B2 shall meet the following requirements:

Note: In the table:

Letter L means that the point or segment is located on the left of VV line.

Letter R means that the point or segment is located on the right of VV line.

Letter U means the point or segment is located above HH line.

Letter D means the point or segment is located below HH line.

Points of Segments	Designation	Illuminances Lux	Horizontal Distances (cm)	Vertical Distances (cm)
	On & above line H/H2, or On & above line H/H3/H4	1 Max		
1	HV	1 max	0	0
2	B 50R	0.5 max	R 150	U 25
3	75 L	20 min	L 50	D 25
4	50 R	20 max	R 150	D 37.5
5	25 R1	30 max	R 150	D 75
6	50 V	12 min	0	D 37.5
7	50 L	20 min	L 75	D 37.5
8	25 R2	4 min	R 396	D 75
9	25 L1	4 min	L 396	D 75
10	25 R3	2min	R 670	D 75
11	25 L2	2min	L 670	D 75
12	15 R	1min	R 910	D 125
13	15 L	1 min	L 910	D 125
14		(*)	R 350	U 175
15		(*)	0	U 175
16		(*)	L 350	U 175
17		(*)	R 175	U 87.5
18		(*)	0	U 87.5
19		(*)	L 175	U 87.5
20		0.1 min	R 350	0
21		0.2 min	R 175	0
A to B	Segment I	6 min	R 225 to L 225	D 37.5
C to D	Segment II	6 max	L 140 to L 396	U 45
E to F	Segment III & under	20 max	R 417 to R 375	D 187.5
	E max L	70 max	Left of VV Line	Above D 75
	E max R	50 max	Right of VV line	

(*) The illumination values at points 14 through 19 shall be such that:

$$14 + 15 + 16 \geq 0.3 \text{ lux and } 17 + 18 + 19 \geq 0.6 \text{ lux.}$$

B2.3 PROVISIONS CONCERNING MAIN-BEAM

B2.3.1 In the case of a headlamp designed to provide a main-beam and a dipped-beam, measurements of the illumination produced on the screen by the main-beam shall be taken with the same headlamp alignment as for measurements under paragraph B2.2.6 above; in the case of a headlamp providing a main-beam only, it shall be so adjusted that the area of maximum illumination is centered on the point of intersection of lines HH and VV; such a headlamp needs meet only the requirements referred to in paragraph B2.3. Test voltages are the same as in paragraph B2.2.5.1

B2.3.2 It is possible to use several light sources for the main-beam, these light sources being listed in AIS 034. The following provisions shall be met:

B2.3.2.1 The point of intersection (HV) of the lines HH and VV shall be situated within the isolux representing 80 % of the maximum illuminance. This maximum illuminance, hereunder designated as E_{max} , shall lie between 70 and 180 lux.

B2.3.2.2 The reference mark shall be obtained by means of the formula:

Reference mark = $0.208 E_{max}$ (See para 12.0)

This value shall be rounded off to the value: 17.5 - 20 - 25 - 27.5 - 30 - 37.5

B2.3.2.3 Starting from point HV, horizontally to the right and left, the illuminance shall be not less than 40 lux up to a distance of 1.125m and not less than 10 lux up to a distance of 2.25 m.

B2.4 The screen illuminance values mentioned in paragraphs B2.2.6 to B2.3.2.3 above shall be measured by means of a photo-receptor, the effective area of which shall be contained within a square of 65 mm side.

B2.5 PROVISIONS CONCERNING MOVABLE REFLECTORS

B2.5.1 With the lamp fixed according to all the positions described in relevant paragraph of Table:2 of this standard, the headlamp must meet the photometric requirements of paragraph B2.2 or B2.3, or both.

B2.5.2 Additional tests are made after the reflector has been tilted vertically upwards by the angle quoted in relevant paragraph of Table:2 of this standard or 2° ; whichever is smaller, by means of the headlamp aiming devices. The headlamp is then re-aimed downwards (by means of the goniometer), and the photometric specifications must be met at the following points:

Dipped-beam: HV and 75 L respectively
Main-beam: E max, HV as % of Emax

If the aiming devices do not allow a continuous movement, the position nearest to 2° is chosen.

- B2.5.3 The reflector is brought back to its nominal angular position as defined in paragraph B2.2.2, and the goniometer is set back to its position of origin. The reflector is tilted vertically downwards by the angle quoted in relevant paragraph of Table:2 of this standard or 2°, whichever is smaller, by means of the headlamp aiming device. The headlamp is then re-aimed upwards (by means of the goniometer for example) and points as in paragraph B2.5.2 are checked.

ANNEX : B3

(See para 5.2 and B1.1.1)

**COLORIMETRIC REQUIREMENTS FOR HEADLAMP EQUIPED WITH
GAS-DISCHARGE LIGHT SOURCES**

The trichromatic coordinates of the light of the beams emitted by headlamps using gas discharge light sources must be in the following boundaries:

Limit towards blue	: $x \geq 0.310$
Yellow	: $x \leq 0.500$
Green	: $y \leq 0.150 + 0.640x$
Green	: $y \leq 0.440$
Purple	: $y \geq 0.050 + 0.750x$
Red	: $y \geq 0.382$

ANNEX : B4
 (See para B1.1.6)
**TEST FOR STABILITY OF PHOTOMETRIC
 PERFORMANCE OF HEADLAMPS IN OPERATION.**

TESTS ON COMPLETE HEADLAMPS

Once the photometric values have been measured according to the requirements of this standard in points for E_{\max} for main-beam and HV, 50L, B50R for headlamps designed for left-hand traffic, a complete headlamp sample shall be tested for stability of photometric performance in operation. "Complete headlamp" shall be understood to mean the complete lamp itself, including those surrounding body parts and lamps, which could influence its thermal dissipation.

B4.1. TEST OF STABILITY OF PHOTOMETRIC PERFORMANCE

The tests shall be carried out in a dry and still atmosphere at an ambient temperature of $23^{\circ} \pm 5^{\circ}\text{C}$, the complete headlamp being mounted on a base representing the correct installation on the vehicle.

B4.1.1. Clean headlamp

The headlamp shall be operated for 12 hours as described in subparagraph B4.1.1.1 and checked as prescribed in subparagraph B4.1.1.2.

B4.1.1.1 Test procedure

The headlamp shall be operated for a period according to the specified time, so that:

B4.1.1.1.1

- (a) In the case where only one lighting function (driving or dipped-beam) is to be approved, the corresponding light source is lit for the prescribed time, ⁽¹⁾
- (b) In the case of a reciprocally incorporated dipped-beam lamp and main-beam lamp or in the case of a reciprocally incorporated front fog lamp & main-beam headlamp:

(1) When the tested headlamp is grouped and/or reciprocally incorporated with signaling lamps, the latter shall be lit for the duration of the test. In the case of a direction indicator lamp, it shall be lit in flashing operation mode with an on/off time ratio of approximately one to one.

AIS-012

If the applicant declares that the headlamp is to be used with a single filament lit, ⁽¹⁾ the test shall be carried out in accordance with this condition, activating ⁽²⁾ each specified function successively for half the time specified in paragraph B4.1.1.

In all other cases, ^{(1), (2)} the headlamp shall be subjected to the following cycle until the time specified is reached:

15 minutes, passing-beam lit

5 minutes, all functions lit;

- (c) In the case of grouped lighting functions, all the individual functions shall be lit simultaneously for the time specified for individual lighting functions (a), also taking into account the use of reciprocally incorporated lighting functions (b), according to the manufacturer's specifications.

B4.1.1.1.2. **Test voltage**

The voltage for the ballast is 13.5 ± 0.1 volts for 12V network system, or other wise specified in the application for approval. If there are reciprocally incorporated filament lamps, the voltage producing the reference flux shall be used.

B4.1.1.2. **Test Results**

B4.1.1.2.1. **Visual inspection**

Once the headlamp has been stabilized to the ambient temperature, the headlamp lens and the external lens, if any, shall be cleaned with a clean, damp cotton cloth. It shall then be inspected visually, no distortion, deformation, cracking or change in color of either the headlamp lens or the external lens, if any, shall be noticeable.

B4.1.1.2.2. **Photometric Test**

To comply with the requirements of this standard, the photometric values shall be verified in the following points:

Passing-beam:

50L - B50R - HV for headlamps designed for left-hand traffic.

Main-beam:

Point of E_{\max}

Another aiming may be carried out to allow for any deformation of the headlamp base due to heat (the change of the position of the cut-off line is covered in paragraph B4.2 of this Annex).

(1) Should two or more light sources be simultaneously lit when headlamp flashing is used, this shall not be considered as being normal use of the filaments simultaneously.

(2) See foot note (1) on page 59

A 10% discrepancy between the photometric characteristics and the values measured prior to the test is permissible, including the tolerances of the photometric procedure.

B4.1.2. Dirty Headlamp

After being tested as specified in subparagraph B4.1.1 above, the headlamp shall be operated for one hour as described in subparagraph B4.1.1.1 after being prepared as prescribed in subparagraph B4.1.2.1, and checked as prescribed in subparagraph B4.1.1.2.

B4.1.2.1. Preparation of the headlamp

B4.1.2.1.1 Test mixture

B4.1.2.1.1.1 For headlamp with the outside lens in glass:

The mixture of water and a polluting agent to be applied to the headlamp shall be composed of:

9 parts by weight of silica sand with a particle size of 0-100 µm,

1 part by weight of vegetal carbon dust (beechwood) with a particle size of 0-100 µm,

0.2 parts by weight of NaCMC ⁽¹⁾, and

An appropriate quantity of distilled water, with a conductivity of ≤1 mS/m.

The mixture must not be more than 14 days old.

B4.1.2.1.1.2 For headlamp with outside lens in plastic material:

The mixture of water and polluting agent to be applied to the headlamp shall be composed of:

9 parts by weight of silica sand with a particle size of 0-100 µm,

1 part by weight of vegetal carbon dust (beechwood) with a particle size of 0-100 µm,

0.2 part by weight of NaCMC ⁽¹⁾,

13 parts by weight of distilled water with a conductivity of ≤1mS/m, and

2 ± 1 parts by weight of surface-actant ⁽²⁾.

The mixture must not be more than 14 days old.

(1) NaCMC represents the sodium of carboxymethylcellulose, customarily referred to as CMC. The NaCMC used in the dirt mixture shall have a degree of substitution (DS) of 0.6-0.7 and viscosity of 200-300 cP for a 2% solution at 20° C.

(2) The tolerance on quantity is due to the necessity of obtaining dirt that correctly spreads out on all the plastic lens.

B4.1.2.1.2. Application of the test mixture to the headlamp

The test mixture shall be uniformly applied to the entire light emitting surface of the headlamp and then left to dry. This procedure shall be repeated until the illuminating value has dropped to 15-20% of the values measured for each following point under the conditions described in this Annex:

Emax in main-beam for a driving/passing lamp & in main-beam for a driving lamp only,

50L and 50V ⁽¹⁾ for a passing lamp only,

B4.1.2.1.3. Measuring equipment

The measuring equipment shall be equivalent to that used during headlamp approval tests. The gas-discharge light source supplied by the applicant shall be used for the photometric verification.

B4.2 TEST FOR CHANGE IN VERTICAL POSITION OF THE CUT-OFF LINE UNDER THE INFLUENCE OF HEAT

This test consists of verifying that the vertical drift of the cut-off line under the influence of heat does not exceed a specified value for an operating passing lamp.

The headlamp tested in accordance with paragraph B4.1 shall be subjected to the test described in paragraph B4.2.1 without being removed from or readjusted in relation to its test fixture.

If the headlamp has a moving reflector, only the position closest to the average vertical angular stroke is chosen for this test.

B4.2.1. Test for Dipped-Beam Headlamps

The test shall be carried out in a dry and still atmosphere at an ambient temperature of $23^{\circ}\text{C} \pm 5^{\circ}\text{C}$.

Using a mass production gas-discharge light source which has been aged for at least 15 hours, the headlamp shall be operated on dipped-beam without being dismantled from or readjusted in relation to its test fixture. (For the purpose of this test, the voltage shall be adjusted as specified in paragraph B4.1.1.1.2.) The position of the cut-off line in its horizontal part between vv and the vertical line passing through point B50R shall be verified 3 minutes (r_3) and 60 minutes (r_{60}) respectively after operation.

(1) 50V is situated 375 mm below HV on the vertical line v-v on the screen at 25 m distance

The measurement of the variation in the cut-off line position as described above shall be carried out by any method giving acceptable accuracy and reproducible results.

B4.2.2. Test Results

B4.2.2.1 The result expressed in milliradians (mrad) shall be considered as acceptable for a dipped-beam headlamp when the absolute value $\Delta r_1 = |r_3 - r_{60}|$ recorded on the headlamp is not more than 1.0 mrad ($\Delta r_1 \leq 1.0$ mrad)

B4.2.2.2 However, if this value is more than 1.0mrad but not more than 1.5 mrad ($1.0 \text{ mrad} < \Delta r_1 \leq 1.5\text{mrad}$), a second headlamp shall be tested as described in paragraph B4.2.1. after being subjected three consecutive times to the cycle as described below, in order to stabilize the position of mechanical parts of the headlamp on a base representative of the correct installation on the vehicle:

Operation of the passing lamp for one hour (the voltage shall be adjusted as specified in paragraph B4.1.1.1.2.).

Period of rest for one hour.

The headlamp type shall be considered as acceptable if the mean value of the absolute values Δr_1 measured on the first sample and Δr_{11} measured on the second sample is not more than 1.0 mrad.

$$\left(\begin{array}{c} \Delta r_1 + \Delta r_{11} \leq 1.0 \text{ mrad} \\ 2 \end{array} \right)$$

ANNEX : B 5
(See para B1.1.7)

**REQUIREMENTS FOR LAMPS INCORPORATING
LENSES OF PLASTIC MATERIAL – TESTING OF LENS
OR MATERIAL SAMPLES AND OF COMPLETE LAMPS**

B5.1. GENERAL SPECIFICATIONS

B5.1.1 Refer paragraph Annex : A5.1.1.

B5.1.2 Refer paragraph Annex : A5.1.2.

B5.1.3. The samples of lenses of plastic material or samples of material shall be subjected, with the reflector to which they are intended to be fitted (where applicable), to approval tests in the chronological order indicated in Table A reproduced in Appendix 1 to this Annex.

B5.1.4. However, if the lamp manufacturer can prove that the product has already passed the tests prescribed in paragraphs B5.2.1.to B5.2.5. below, or the equivalent tests pursuant to another Regulation, those tests need not be repeated; only the tests prescribed in Appendix 1, Table B, shall be mandatory.

B5.2. TESTS

B5.2.1. Resistance to Temperature Changes

B5.2.1.1 Tests

Refer paragraph Annex : A5.2.1.1

B5.2.1.2. Photometric Measurements

B5.2.1.2.1. Method

Photometric measurements shall be carried out on the samples before and after the test. These measurements shall be made using a standard lamp, at the following points:

B 50 R and 50 L for the dipped-beam of a passing lamp or a passing/driving lamp

B5.2.1.2.2. Results

The variation between the photometric values measured on each sample before and after the test shall not exceed 10 % including the tolerances of the photometric procedure.

- B5.2.2. **Resistance to Atmospheric and Chemical Agents**
- B5.2.2.1. **Resistance to Atmospheric Agents**
Refer paragraph Annex : A5.2.2.1
- B5.2.2.2. **Resistance to Chemical Agents**
Refer paragraph Annex : A5.2.2.2
- B5.2.2.3. **Results**
Refer paragraph Annex : A5.2.2.3.
- B5.2.2.4. **Resistance to Light Source Radiations**
- B5.2.3. **Resistance to Detergents and Hydrocarbons**
- B5.2.3.1. **Resistance to Detergents**
Refer paragraph Annex : A5.2.3.1.
- B5.2.3.2. **Resistance to Hydrocarbons**
Refer Annex : A5.2.3.2.
- B5.2.3.3. **Results**
Refer Annex A5.2.3.3.
- B5.2.4 Resistance to Mechanical Deterioration**
- B5.2.4.1. **Mechanical Deterioration Method**
Refer paragraph Annex : A5.2.4.1.
- B5.2.4.2. **Results**
Refer paragraph A5.2.4.2.
- B5.2.5 Test of Adherence of Coatings, if any**
- B5.2.5.1. **Preparation of the sample**
Refer paragraph Annex : A5.2.5.1
- B5.2.6 Tests of the Complete Lamp Incorporating a Lens of Plastic Material**
- B5.2.6.1. **Resistance to Mechanical Deterioration of the Lens Surface**
Refer paragraph Annex : A5.2.6.1.
- B5.2.6.2. **Test of Adherence of Coatings, if any**
Refer paragraph Annex : A5.2.6.2.

ANNEX:B 5 – APPENDIX:1
(See para B5.1.3)
CHRONOLOGICAL ORDER OF APPROVAL TESTS

Table A: Tests on plastic materials (lenses or samples of material supplied pursuant to paragraph 7.3 of this standard).

Samples Test		Lenses or samples of material										Lenses			
		1	2	3	4	5	6	7	8	9	10	11	12	13	14
B5:App1.1.1	Limited Photometry (Para.B5.2.1.2)											x	x	x	
B5:App1.1.1.1	Temperature change (para. B5.2.1.1.)											x	x	x	
B5:App1.1.1.2.	Limited photometry (para. B5.2.1.2.)											x	x	x	
B5:App1.1.2.1	Transmission Measurement	x	x	x	x	x	x	x	x	x					
B5:App1.1.2.2.	Diffusion measurement	x	x	x				x	x	x					
B5:App1.1.3.	Atmospheric agents (para. B5.2.2.1.)	x	x	x											
B5:App1.1.3.1.	Transmission Measurement	x	x	x											
B5:App1.1.4.	Chemical agents (para.B5.2.2.2.)	x	x	x											
B5:App1.1.4.1.	Diffusion Measurement	x	x	x											
B5:App1.1.5.	Detergents (para. B5.2.3.1.)				x	x	x								
B5:App1.1.6.	Hydrocarbons (para. B5.2.3.2.)				x	x	x								
B5:App1.1.6.1.	Transmission Measurement				x	x	x								
B5:App1.1.7.	Deterioration (para. B5.2.4.1.)							x	x	x					
B5:App1.1.7.1.	Transmission Measurement							x	x	x					
B5:App1.1.7.2.	Diffusion Measurement							x	x	x					
B5:App1.1.8.	Adherence (para.B5.2.5.)														x
B5:App1.1.9.	Resistance to light source radiations (para B5.2.2.4)										x				

Table B : Tests on complete headlamps (supplied pursuant to paragraph 7.1. of this standard).

Tests		Complete headlamp	
		Sample No.	
		1	2
B5:App1.2.1.	Deterioration (para. B5.2.6.1.1.)	x	
B5:App1.2.2.	Photometry (para. B5.2.6.1.2.)	x	
B5:App1.2.3.	Adherence (para. B5.2.6.2.)		x

-

ANNEX:B 5 – APPENDIX:2

**METHOD OF MEASUREMENT OF THE DIFFUSION
AND TRANSMISSION OF LIGHT**

Refer Annex : A5 – Appendix : 2

ANNEX:B 5 – APPENDIX:3

SPRAY TESTING METHOD

Refer Annex : A5 – Appendix : 3

ANNEX: B 5 – APPENDIX:4

ADHESIVE TAPE ADHERENCE TEST

Refer Annex : A5 – Appendix : 4

ANNEX: B 6
(See para 8.0)

MINIMUM REQUIREMENTS FOR CONFORMITY OF PRODUCTION CONTROL PROCEDURES

B6.1. GENERAL

B6.1.1 The conformity requirements shall be considered satisfied from a mechanical and a geometrical standpoint, if the differences do not exceed inevitable manufacturing deviations within the requirements of this standard.

B6.1.2. With respect to photometric performances, the conformity of mass-produced headlamps shall not be contested if, when testing photometric performances of any headlamp chosen at random and measured at $13.5 V \pm 0.1 V$ or as otherwise specified and;

either

equipped with a removable standard gas-discharge light source according to paragraph B 2.1.3. of Annex : B2 The luminous flux of this gas-discharge light source may differ from the reference luminous flux specified in AIS-034. In this case , the illuminances shall be corrected accordingly.

or

equipped with the serial production gas-discharge light source and the serial ballast. The luminous flux of this light source may deviate from the nominal luminous flux due to light source and ballast tolerances as specified in AIS-034; accordingly the measured illuminances may be corrected by 20% in the favourable direction.

B6.1.2.1. No illuminance value, if measured and corrected according to paragraph B6.1.2. above, deviated unfavourably by more than 20 % from the values prescribed in this standard. For values B 50 R and on line H/H3/H4 and above, the maximum unfavourable deviation may be respectively:

B 50 R	0.20 lx equivalent 20%
	0.30 lx equivalent 30 %
On line H/H3/H4 and above :	0.30 lx equivalent 20 %
	0.45 lx equivalent 30 %

- B6.1.2.2. or if
- B6.1.2.2.1. For the dipped-beam, the values prescribed in this standard are met at HV (with a tolerance of + 0.2 lx) and related to that aiming at one point of each area delimited on the measuring screen (at 25 m) by a circle 15 cm in radius around points B 50 R (with a tolerance of + 0.1 lx), 75 L , 50 V, 25 R1, 25 L2, and on segment I;
- B6.1.2.2.2. and if, for the main-beam, HV being situated within the isolux $0.75 E_{max}$, a tolerance of + 20 % for maximum values and -20 % for minimum values is observed for the photometric values at any measuring point specified in paragraph B2.3 of Annex B2. of this standard.
- B6.1.2.3. If the results of the test described above do not meet the requirements, the alignment of the headlamp may be changed, provided that the axis of the beam is not displaced laterally by more than 0.5° to the right or left and not by more than 0.2° up or down.
- B6.1.2.4. If the results of the tests described above do not meet the requirements, tests on the headlamp shall be repeated using another standard gas-discharge light source or gas-discharge light source and ballast, whatever is applicable according to paragraph B6.1.2. above.
- B6.1.3. With respect to the verification of the change in vertical position of the cut-off line under the influence of heat, the following procedure shall be applied:
- One of the sampled headlamps shall be tested according to the procedure described in paragraph B4.2.1. of Annex: B4 after being subjected three consecutive times to the cycle described in paragraph B4.2.2.2. of Annex : B4
- The headlamp shall be considered as acceptable if Δr (as defined in paragraphs B4.2.1. and B4.2.2. of Annex B4 to this standard)does not exceed 1.5 mrad.
- If this value exceeds 1.5 mrad but is not more than 2.0 mrad, a second sample shall be subjected to the test after which the mean of the absolute values recorded on both samples shall not exceed 1.5 mrad.
- B6.1.4. The chromaticity coordinates as specified in Annex : B3 of this standard shall be complied with.

B6.2. MINIMUM REQUIREMENTS FOR VERIFICATION OF CONFORMITY BY THE MANUFACTURER

For each type of headlamp the holder of the approval mark shall carry out at least the following tests, at appropriate intervals. The tests shall be carried out in accordance with the provision of this standard.

If any sampling shows non-conformity with respect to the type of test concerned, further samples shall be taken and tested. The manufacturer shall take steps to ensure the conformity of the production concerned.

B6.2.1. Nature of Tests

Tests of conformity in this Annex shall cover the photometric characteristics and the verification of the change in vertical position of the cut-off line under the influence of heat.

B6.2.2. Methods used in Tests

B6.2.2.1. Tests shall generally be carried out in accordance with the methods set out in this standard

B6.2.2.2. In any test of conformity carried out by the manufacturer, equivalent methods may be used with the consent of the test agency responsible for approval tests. The manufacturer is responsible for proving that the applied methods are equivalent to those laid down in this standard.

B6.2.2.3. The application of paragraphs B6.2.2.1. and B6.2.2.2. requires regular calibration of test apparatus and its correlation with measurement made by a test agency.

B6.2.2.4. In all cases the reference methods shall be those of this standard, particular for the purpose of administrative verification and sampling.

B6.2.3. Nature of Sampling

Samples of headlamps shall be selected at random from the production of a uniform batch. A uniform batch means a set of headlamps of the same type, defined according to the production methods of the manufacturer.

The assessment shall, in general, cover series production from individual factories. However, a manufacturer may group together records concerning the same type from several factories provided these operate under the same quality system and quality management.

B6.2.4. Measured and Recorded Photometric Characteristics

The sampled headlamps shall be subjected to photometric measurements at the points provided for in the standard, the reading being limited at the points E_{\max} , HV⁽¹⁾, HL, HR⁽²⁾ in the case of a main-beam, and to points B 50 R, HV, 50 V, 75 L and 25 R2 in the case of the dipped-beam (see figure B1 /B2).

B6.2.5. Criteria Governing Acceptability

The manufacturer is responsible for carrying out a statistical study of the test results and for defining, in agreement with the competent authority, criteria governing acceptability of his products in order to meet the specifications laid down for verification of conformity of products in paragraph 8.1 of this standard.

The criteria governing acceptability shall be such that, with a confidence level of 95%, the minimum probability of passing a spot check in accordance with Annex B:7 (first sampling) would be 0.95.

-
- (1) (When the main-beam is reciprocally incorporated with the dipped-beam, HV in the case of the main-beam shall be the same measuring point as in the case of the dipped-beam)
 - (2) (HL and HR: points "hh" located at 1.125 m to the left and to the right of point HV respectively)

ANNEX: B 7
(See para 8.0)

**MINIMUM REQUIREMENTS FOR
SAMPLING BY AN INSPECTOR**

B7.1. GENERAL

B7.1.1. The conformity requirements shall be considered satisfied from a mechanical and a geometrical standpoint in accordance with the requirements of this Standard, if any, if the differences do not exceed inevitable manufacturing deviations.

B7.1.2. With respect to photometric performances, the conformity of mass-produced headlamps shall not be contested if, when testing photometric performances of any headlamp chosen at random and measured at $13.5 \text{ V} \pm 0.1 \text{ V}$ or as otherwise specified and;

either

equipped with a removable standard gas-discharge light source according to paragraph B 2.1,3 of Annex B2. The luminous flux of this gas-discharge light source may differ from the reference luminous flux specified in AIS-034. In this case , the illuminances shall be corrected accordingly.

or

equipped with the serial production gas-discharge light source and the serial ballast. The luminous flux of this light source may deviate from the nominal luminous flux due to light source and ballast tolerances as specified in AIS-034; accordingly the measured illuminances may be corrected by 20% in the favourable direction.

B7.1.2.1. No measured value deviates unfavourably by more than 20 per cent from the values prescribed in relevant Annex

In the glare zone the maximum deviation may be respectively:

B 50 R	:	0.20 lx equivalent 20 %
		0.30 lx equivalent 30 %
On line H/H3/H4) and above	:	0.30 lx equivalent 20 %
		0.45 lx equivalent 30 %

- B7.1.2.2. or if
- B7.1.2.2.1. for the dipped-beam, the values prescribed in this standard are met at HV (with a tolerance of + 0.2 lx) and related to that aiming at one point of each area delimited on the measuring screen (at 25 m) by a circle 15 cm in radius around points B 50 R ⁽¹⁾ (with a tolerance of 0.1 lx), 75 L , 50 V, 25 R1, 25 L2, and on Segment I;
- B7.1.2.2.2. and if, for the main-beam, HV being situated within the isolux $0.75 E_{\max}$, a tolerance of + 20 per cent for maximum values and - 20 per cent for minimum values is observed for the photometric values at any measuring point specified in paragraph B2.3 of Annex B2 . The reference mark is disregarded.
- B7.1.2.3. If the results of the test described above do not meet the requirements, the alignment of the headlamp may be changed, provided that the axis of the beam is not displaced laterally by more than 0.5° to the right or left and not by more than 0.2° up or down.
- B7.1.2.4. If the results of the tests described above do not meet the requirements, tests on the headlamp shall be repeated using another standard gas-discharge light source or gas-discharge light source and ballast, whatever is applicable according to paragraph B7.1.2 above.
- B7.1.3 With respect to the verification of the change in vertical position of the cut-off line under the influence of heat, the following procedure shall be applied:
- One of the sampled headlamps shall be tested according to the procedure described in paragraph B4.2.1 of Annex B4 after being subjected three consecutive times to the cycle described in paragraph B4.2.2.2. of Annex B4.
- The headlamp shall be considered acceptable if Δr (as defined in paragraphs B4.2.1 and B4.2.2 of Annex B4) does not exceed 1.5 mrad.
- If this value exceeds 1.5 mrad but is not more than 2.0 mrad, a second sample shall be subjected to the test after which the mean of the absolute values recorded on both samples shall not exceed 1.5 mrad.
- B7.1.4 The chromaticity coordinates as specified in Annex: B3 shall be complied with.

B7.2. FIRST SAMPLING

In the first sampling four headlamps are selected at random. The first sample of two is marked A, the second sample of two is marked B.

B7.2.1. The Conformity is not Contested

B7.2.1.1. Following the sampling procedure shown in Figure A3 of relevant Annex the conformity of mass-produced headlamps shall not be contested if the deviations of the measured values of the headlamps in the unfavorable directions are:

B7.2.1.1.1. Sample A

A1:	one headlamp		0 %
	one headlamp	not more than	20%
A2:	both headlamps	more than	0 %
	but	not more than	20%
	go to sample B		

B7.2.1.1.2. Sample B

B1:	Both headlamps		0 %
-----	----------------	--	-----

B7.2.1.2. or if the conditions of paragraph B7.1.2.2. for Sample A are fulfilled.

B7.2.2. The Conformity is Contested

B7.2.2.1. Following the sampling procedure shown in Figure A3 of relevant Annex the conformity of mass-produced headlamps shall be contested and the manufacturer requested to make his production meet the requirements (alignment) if the deviations of the measured values of the headlamps are:

B7.2.2.1.1. Sample A

A3:	one headlamp	not more than	20%
	one headlamp	more than	20%
	but	not more than	30%

B7.2.2.1.2. **Sample B**

B2:	in the case of A2		
	one headlamp	more than	0%
	But	not more than	20%
	one headlamp	not more than	20%
B3:	in the case of A2		
	one headlamp		0%
	one headlamp	more than	20%
	but	not more than	30%

B7.2.2.2. or if the conditions of paragraph B7.1.2.2. for sample A are not fulfilled.

B7.2.3. **Approval Withdrawn**

Conformity shall be contested and paragraph 8.3 applied if, following the sampling procedure shown in Figure A3 of relevant Annex, the deviations of the measured values of the headlamps are:

B7.2.3.1. **Sample A**

A4:	one headlamp	not more than	20%
	one headlamp	more than	30%
A5:	Both headlamps	more than	20%

B7.2.3.2. **Sample B**

B4:	in the case of A2		
	one headlamp	more than	0%
	but	not more than	20%
	one headlamp	more than	20%
B5:	in the case of A2		
	both headlamps	more than	20%
B6:	in the case of A2		
	one headlamp		0%
	one headlamp	more than	30%

B7.2.3.3. or if the conditions of paragraph B7.1.2.2. for samples A and B are not fulfilled.

B7.3. REPEATED SAMPLING

In the case of A3, B2, B3 a repeated sampling, third sample C of two headlamps, and fourth sample D of two headlamps, selected from stock manufactured after alignment, is necessary within two months time after the notification.

B7.3.1. The Conformity is Not Contested

B7.3.1.1. Following the sampling procedure shown in Figure A3 of relevant Annex the conformity of mass-produced headlamps shall not be contested if the deviations of the measured values of the headlamps are:

B7.3.1.1.1. Sample C

C1:	one headlamp		0%
	one headlamp	not more than	20%
C2:	both headlamps	more than	0%
	But	not more than	20%
	go to sample D		

B7.3.1.1.2. Sample D

D1:	in the case of C2		
	both headlamps		0%

B7.3.1.2. or if the conditions of paragraph B7.1.2.2. for sample C are fulfilled.

B7.3.2. The Conformity is Contested

B7.3.2.1. Following the sampling procedure shown in Figure A3 of relevant Annex the conformity of mass-produced headlamps shall be contested and the manufacturer requested to make his production meet the requirements (alignment) if the deviations of the measured values of the headlamps are:

B7.3.2.1.1. Sample D

D2:	in the case of C2		
	one headlamp	more than	0%
	but	not more than	20%
	one headlamp	not more than	20%

B7.3.2.1.2. or if the conditions of paragraph B7.1.2.2 for sample C are not fulfilled:

B7.3.3. Approval Withdrawn

Conformity shall be contested and paragraph 8.3 of this standard applied if, following the sampling procedure shown in Figure A3 of relevant Annex, the deviations of the measured values of the headlamps are:

B7.3.3.1. Sample C

C3:	one headlamp	not more than	20%
	one headlamp	more than	20%
C4:	both headlamps	more than	20%

B7.3.3.2. Sample D

D3:	in the case of C2		
	one headlamp	0 or more than	0%
	one headlamp	more than	20%

B7.3.3.3. or if the conditions of paragraph B7.1.2.2. for samples C and D are not fulfilled.

B7.4. CHANGE OF THE VERTICAL POSITION OF THE CUT-OFF LINE

With respect to the verification of the change in vertical position of the cut-off line under the influence of heat, the following procedure shall be applied:

One of the headlamps of sample A after sampling procedure in Figure A3 relevant Annex shall be tested according to the procedure described in paragraph B4.2.1. of Annex: B4 after being subjected three consecutive times to the cycle described in paragraph B4.2.2.2. of Annex : B4

The headlamp shall be considered as acceptable if Δr does not exceed 1.5 mrad.

If this value exceeds 1.5 mrad but is not more than 2.0 mrad, the second headlamp of sample A shall be subjected to the test after which the mean of the absolute values recorded on both samples shall not exceed 1.5 mrad.

However, if this value of 1.5 mrad on sample A is not complied with, the two headlamps of sample B shall be subjected to the same procedure and the value of Δr for each of them shall not exceed 1.5 mrad.

ANNEX: B 8
(See para 12.6)

CENTRE OF REFERENCE

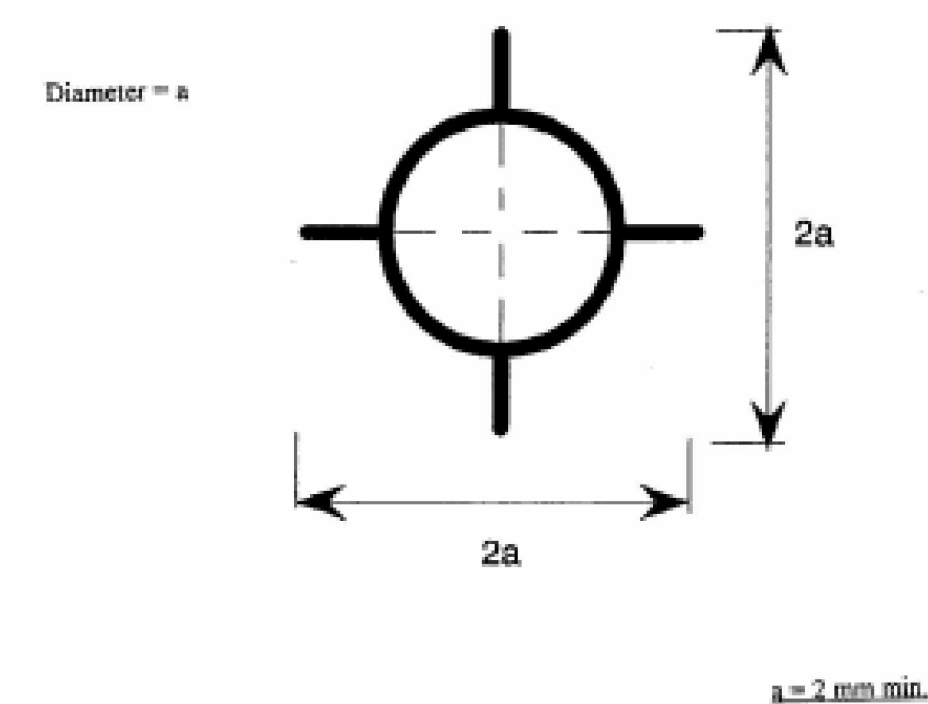

This optional mark of the center of reference shall be positioned on the lens at its intersection with the reference axis of the dipped-beam, and also on the lenses of the main-beams when they are neither grouped nor combined nor reciprocally incorporated with a dipped-beam.

The above drawing represents the mark of the center of reference as projected on a plane substantially tangent to the lens about the center of the circle. The lines constituting this mark may either be solid or dotted.

ANNEX: B 9
(See para. B2.2.5.1)

VOLTAGE MARKINGS

This marking must be placed on the main body of each headlamp containing only gas discharge light sources and ballast, and on each external part of the ballast.
 The ballast(s) is(are) designed for a ** Volts network system.



This marking must be placed on the main body of each headlamp containing at least one gas discharge light source and ballast.
 The ballast(s) is (are) designed for a ** Volts network system.



None of the filament lamps which the headlamp contains is designed for a 24 Volts network system.

ANNEX : C1
(See para 5.3)

REQUIREMENTS FOR FRONT FOG LAMP

- C1.1 GENERAL REQUIREMENTS FOR FRONT FOG LAMP**
- C1.1.1 Each sample submitted in conformity with paragraph 7.1 of this standard above shall meet the specifications set forth in Annex : C1, C2, C3 and Annex L of this standard.
- C1.1.2 The front fog lamps shall be so designed and constructed that in normal use, despite the vibrations to which they may then be subjected, their satisfactory operation continues to be ensured and they retain the characteristics prescribed by this standard. The correct position of the lens shall be clearly marked and the lens and reflector shall be so secured as to prevent any rotation during use. Conformity with the requirements of this paragraph shall be verified by visual inspection and, where necessary, by a trial fitting.
- C1.1.2.1 Front fog lamps shall be fitted with a device enabling them to be so adjusted on the vehicles as to comply with the rules applicable to them. Such a device need not be fitted on units in which the reflector and the diffusing lens cannot be separated, provided the use of such units is confined to vehicles on which the front fog lamp setting can be adjusted by other means. Where a front fog lamp and another front lamp, each equipped with its own filament lamp, are assembled to form a composite unit, the adjusting device shall enable each optical system individually to be duly adjusted.
- C1.1.2.2 However, these provisions shall not apply to front lamp assemblies whose reflectors are indivisible. For this type of assembly the requirements of paragraph C2.2.6 of Annex :C2 shall apply.
- C1.1.3 Complementary tests shall be done according to the requirements of Annex : C4 to ensure that in use there is no excessive change in photometric performance.
- C1.1.4 If the lens of the front fog lamp is of plastic material, tests shall be done according to the requirements of Annex : C5.

ANNEX : C2
(See para 5.3 and C1.1.1)

**PHOTOMETRIC TEST PROCEDURE AND
ILLUMINATION REQUIREMENTS FOR
FRONT FOG LAMP**

C2.1 ILLUMINATION

- C2.1.1. Front fog lamps shall be so designed as to provide illumination with limited dazzle.
- C2.1.2. The illumination produced by the front fog lamp shall be determined by means of a vertical screen set up 25 m forward of the lens of the front fog lamp. The point HV is the base of the perpendicular from the center of the lamp to the screen. The line hh is the horizontal through HV (See Figure C1).
- C2.1.3. A colorless-bulb standard (reference) filament lamp of the category specified by the manufacturer, designed for a rated voltage of 12 V and supplied by the manufacturer, shall be used. During the checking of the front fog lamp the voltage of the terminals of the filament lamp shall be regulated so as to obtain the following characteristics:

Filament Lamp Category	Approximate supply voltage (V) for measurement	Light flux in Lumens
H1	12	1,150
H2	12	1,300
H3	12	1,100
H4	12	750 (*)
H7	12	1,100
H8	12	600
HB3	12	1,300
HB4	12	825
H27W / 1	12	350
H27W / 2	12	350
H10	12	600
H11	12	1,000
H12	12	775

(*) 55 W filament

The front fog lamp shall be deemed satisfactory if the photometric requirements are met with at least one standard 12 V filament lamp.

AIS-012

- C2.1.4. The beam shall produce on the screen, over a width of not less than 2.25 m on both sides of the line VV, a symmetrical cut-off approximating sufficiently closely to the horizontal to enable adjustment to be performed with its aid.
- C2.1.5. The front fog lamp shall be so directed that the cut-off on the screen is 50 cm below the line hh.
- C2.1.6. When so adjusted, the front fog lamp shall meet the requirement set out in paragraph C2.1.7.below.
- C2.1.7. The illumination produced on the screen (see Figure C1) shall meet the following requirements:

Position on measuring screen		Illumination required, in lux
Zone	Zone limits	
A	225 cm on both sides of the line VV & 75cm above hh	≥ 0.15 and ≤ 1
B	1,250 cm on both the sides of the line VV and 150 cm above hh, including hh (except zone A)	≤ 1
C	1,250 cm on both sides of the line VV and starting from 150 cm above hh. The luminous intensity of the front fog lamp in any direction forming an angle of more than 15° above the horizontal shall be limited to 200cd.	≤ 0.5
D	450 cm on both sides of the line VV and comprised between the parallels to hh respectively situated 75 and 150 cm below hh	On each vertical line in this zone there shall be at least one point (a,b, c) where the illumination is ≥ 1.5
E	From 450 cm to 1,000 cm on both sides of zone D and comprised between the parallels to hh respectively situated 75 and 150 cm below hh	On each vertical line in this zone there shall be at least one point where the illumination is ≥ 0.5

Note: The illumination specifications also apply to the straight lines constituting the boundaries of the zones. The strictest specification shall be applied in respect to straight lines contiguous to two zones. The illumination shall be measured either in white light or in colored light as prescribed by the manufacturer for use of the front fog lamp in normal service. No variations in illumination detrimental to satisfactory visibility shall exist in either of the zones B and C.

- C.2.1.8. The screen illumination referred to in paragraph C2.1.7 above shall be measured by means of a photo-electric cell having a useful area comprised within a square of 65 mm side.

ANNEX : C3
 (See para 5.3 and C.1.1.1)

C3.1 COLOUR

Approval may be obtained for a type of front fog lamp emitting either white or yellow light. The coloring, if any, of the beam may be obtained either through the filament lamp bulb or through the lens of the front fog lamp or by any other suitable means.

C3.2 When the color of light emitted is white , it shall be expressed in CIE trichromatic coordinates and the light of beam shall be in following boundaries:

- Limit towards blue : $x \geq 0.310$
- Limit towards yellow : $x \leq 0.500$
- Limit towards green : $y \leq 0.150 + 0.640 x$
- Limit towards green : $y \leq 0.440$
- Limit towards purple : $y \geq 0.050 + 0.750 x$
- Limit towards red : $y \geq 0.382$

C3.3 When the color of light emitted is yellow , it shall be expressed in CIE trichromatic coordinates and the light of beam shall be in following boundaries:

Limit Towards	
Red	$y \geq 0.138 + 0.580x$
Green	$y \leq 1.290 x - 0.100$
White	$y \geq -x + 0.940$ and $y \geq 0.440$
Spectral value	$y \leq -x + 0.992$

ANNEX : C 4
(See para C1.1.3)

TEST FOR STABILITY OF PHOTOMETRIC PERFORMANCE OF FRONT FOG LAMP IN OPERATION

TESTS ON COMPLETE FRONT FOG LAMPS

Once the photometric values have been measured according to the prescriptions of this Standard in the point of maximum illumination in zone D (E_{max}) and in point HV, a complete front fog lamp sample shall be tested for stability of photometric performance in operation. "Complete front fog lamp" shall be understood to mean the complete lamp itself including those surrounding body parts and lamps, which could influence its thermal dissipation.

C4.1. TEST FOR STABILITY OF PHOTOMETRIC PERFORMANCE

The tests shall be carried out in a dry and still atmosphere at an ambient temperature of $23^{\circ}\text{C} \pm 5^{\circ}\text{C}$, the complete front fog lamp being mounted on a base representing the correct installation on the vehicle.

C4.1.1. Clean Front Fog Lamp

The front fog lamp shall be operated for 12 hours as described in subparagraph C4.1.1.1. and checked as prescribed in subparagraph C4.1.1.2.

C4.1.1.1 Test procedure

The front fog lamp shall be operated for the specified time so that:⁽¹⁾

- C4.1.1.1.1.** (a) In the case where only a front fog lamp is to be approved, the corresponding filament lamp(s) is (are) lit for the prescribed time;
- (b) In the case of a front fog lamp reciprocally incorporated with another function: If the applicant declares that the front fog lamp is to be used with a single filament lit ⁽¹⁾ at a time, the test shall be carried out in accordance with this condition, activating each specified function successively for half the time specified in paragraph C4.1.1.;

(1) Should two or more filaments be simultaneously lit when headlamp flashing is used, this shall not be considered as being normal use of the filaments simultaneously.

When the tested headlamp is grouped and/or reciprocally incorporated with signaling lamps, the latter shall be lit for the duration of the test. In the case of a direction indicator lamp, it shall be lit in flashing operation mode with an on/off time ratio of approximately one to one

AIS-012

In all other cases, ⁽¹⁾ the front fog lamp shall be subjected to the following cycle until the time specified is reached:

15 minutes, front fog lamp filament(s) lit,

5 minutes, all filaments (that can be lit simultaneously);

- (c) In the case of grouped lighting functions all the individual functions shall be lit simultaneously for the time specified for individual lighting functions (a), also taking into account the use of reciprocally incorporated lighting functions, according to the manufacturer's specifications.

C4.1.1.1.2. **Test voltage**

The voltage of the filament lamp shall be adjusted so as to supply 90 % of the maximum wattage specified in AIS-034 for filament lamps. The applied wattage shall in all cases comply with the corresponding value of a filament lamp of 12 V rated voltage, except if the applicant for approval specifies that the front fog lamp may be used at a different voltage. In the latter case, the test shall be carried out with the filament lamp of which the wattage is the highest that can be used.

C4.1.1.2. **Test Results**

C4.1.1.2.1. **Visual inspection**

Once the front fog lamp has been stabilized to the ambient temperature, the front fog lamp lens and the external lens, if any, shall be cleaned with a clean, damp cotton cloth. It shall then be inspected visually; no distortion, deformation, cracking or change in color of either the front fog lamp lens or the external lens, if any, shall be noticeable.

C4.1.1.2.2. **Photometric test**

To comply with the requirements of this standard, the following photometric values shall be verified in the following points: HV, and point of Emax in zone D.

Another aiming may be carried out to allow for any deformation of the front fog lamp base due to heat (the change of the position of the cut-off line is covered in paragraph C4.2).

(1) Should two or more filaments be simultaneously lit when headlamp flashing is used, this shall not be considered as being normal use of the filaments simultaneously.

When the tested headlamp is grouped and/or reciprocally incorporated with signaling lamps, the latter shall be lit for the duration of the test. In the case of a direction indicator lamp, it shall be lit in flashing operation mode with an on/off time ratio of approximately one to one

A 10 % discrepancy between the photometric characteristics and the values measured prior to the test is permissible including the tolerances of the photometric procedure.

C4.1.2. Dirty Front Fog Lamp

After being tested as specified in subparagraph C4.1.1. above, the front fog lamp shall be operated for one hour as described in subparagraph C4.1.1.1., after being prepared as prescribed in subparagraph C4.1.2.1., and checked as prescribed in subparagraph C4.1.1.2.

C4.1.2.1 Preparation of the front fog lamp

C4.1.2.1.1 Test mixture

C4.1.2.1.1.1. For front fog lamp with the outside lens in glass:

The mixture of water and a polluting agent to be applied to the front fog lamp shall be composed of:

9 parts by weight of silica sand with a particle size of 0-100 micrometres,

1 part by weight of vegetal carbon dust (beechwood) with a particle size of 0-100 micrometres,

0.2 part by weight of NaCMC ⁽¹⁾ .

and an appropriate quantity of distilled water, with a conductivity of < 1 mS/m.

The mixture must not be more than 14 days old.

C4.1.2.1.1.2. For front fog lamp with outside lens in plastic material:

The mixture of water and polluting agent to be applied to the front fog lamp shall be composed of:

9 parts by weight of silica sand with a particle size of 0-100 micrometres,

1 part by weight of vegetal carbon dust (beechwood) with a particle size of 0-100 micrometres,

0.2 part by weight of NaCMC ⁽¹⁾.

13 parts by weight of distilled water with a conductivity of < 1 mS/m, and

2 +/- 1 parts by weight of surface-actant.⁽²⁾

The mixture must not be more than 14 days old.

(1) NaCMC represents the sodium salt of carboxymethylcellulose, customarily referred to as CMC. The NaCMC used in the dirt mixture shall have a degree of substitution (DS) of 0.6-0.7 and a viscosity of 200-300 cP for a 2 % solution at 20 degrees C.

(2) The tolerance on quantity is due to the necessity of obtaining a dirt that correctly spreads out on all the plastic lens.

C4.1.2.1.2. Application of the test mixture to the front fog lamp

The test mixture shall be uniformly applied to the entire light emitting surface of the front fog lamp and then left to dry. This procedure shall be repeated until the illumination value has dropped to 15-20 % of the values measured for the following point under the conditions described in this annex:
point of Emax in zone D.

C4.1.2.1.3. Measuring equipment

The measuring equipment shall be equivalent to that used during front fog lamp approval tests. A standard (reference) filament lamp shall be used for the photometric verification.

C4.2. TEST FOR CHANGE IN VERTICAL POSITION OF THE CUT-OFF LINE UNDER THE INFLUENCE OF HEAT

This test consists of verifying that the vertical drift of the cut-off line under the influence of heat does not exceed the specified value for an operating front fog lamp. The front fog lamp tested in accordance with paragraph C4.1, shall be subjected to the test described in C4.2.1., without being removed from or readjusted in relation to its test fixture.

C4.2.1. Test

The test shall be carried out in a dry and still atmosphere at an ambient temperature of $23^{\circ}\text{C} \pm 5^{\circ}\text{C}$.
Using a mass production filament lamp which has been aged for at least one hour the front fog lamp shall be operated without being dismantled from or readjusted in relation to its test fixture. (For the purpose of this test, the voltage shall be adjusted as specified in paragraph C4.1.1.1.2.). The position of the cut-off line between a point situated 2.25 m left and a point situated 2.25 m right of the line VV (see paragraph C2.1.4 of Annex: C2) shall be verified after three minutes (r3) and 60 minutes (r60) respectively of operation. The measurement of the variation in the cut-off line position as described above shall be carried out by any method giving acceptable accuracy and reproducible results.

C4.2.2 Test Results

C4.2.2.1 The result expressed in milliradians (mrad) shall be considered acceptable when the absolute value $\Delta rI = (r3 - r60)$ recorded on this front fog lamp is not more than 2 mrad ($\Delta rI < 2 \text{ mrad}$).

AIS-012

C4.2.2.2. However, if this value is more than 2 mrad but not more than 3 mrad ($2 \text{ mrad} < \Delta r_I < 3 \text{ mrad}$) a second front fog lamp shall be tested as described in paragraph 2.1 after being subjected three consecutive times to the cycle as described below, in order to stabilize the position of mechanical parts of the front fog lamp on a base representative of the correct installation on the vehicle:

operation of the front fog lamp for one hour (the voltage shall be adjusted as specified in paragraph C4.1.1.1.2.).

Period of rest for one hour

The front fog lamp type shall be considered acceptable if the mean value of the absolute values Δr_I measured on the first sample and Δr_{II} measured on the second sample is not more than 2 mrad.

$$\frac{\Delta r_I + \Delta r_{II}}{2} \leq 2 \text{ mrad}$$

ANNEX : C 5
(See para C1.1.4)

**REQUIREMENTS FOR LAMPS INCORPORATING
LENSES OF PLASTIC MATERIAL – TESTING OF LENS
OR MATERIAL SAMPLES AND OF COMPLETE LAMPS**

C5.1. GENERAL SPECIFICATIONS

Refer paragraph Annex:A5.1

C5.2. TESTS

C5.2.1. Resistance to Temperature Changes

C5.2.1.1 Tests

Refer paragraph Annex: A5.2.1.1

C5.2.1.2. Photometric Measurements

C5.2.1.2.1. Method

Photometric measurements shall be carried out on the samples before and after the test. These measurements shall be made using a standard lamp, at the following points:

HV and Emax Zone D.

C5.2.1.2.2. Results

The variation between the photometric values measured on each sample before and after the test shall not exceed 10 % including the tolerances of the photometric procedure.

C5.2.2. Resistance to Atmospheric and Chemical Agents

C5.2.2.1. Resistance to Atmospheric Agents

Refer paragraph A5.2.2.1

C5.2.2.2. Resistance to Chemical Agents

Refer paragraph A5.2.2.2

C5.2.3. Resistance to Detergents and Hydrocarbons

C5.2.3.1. Resistance to Detergents

Refer paragraph A5.2.3.1

- C5.2.3.2. **Resistance to Hydrocarbons**
Refer paragraph A5.2.3.2
- C5.2.4. **Resistance to Mechanical Deterioration**
- C5.2.4.1. **Mechanical Deterioration Method**
Refer paragraph A5.2.4.1
- C5.2.4.2. **Results**
Refer paragraph A5.2.4.2
- C5.2.5. **Test of Adherence of Coatings, if any**
Refer paragraph A5.2.5
- C5.2.6. **Tests of the Complete Fog Lamp Incorporating a Lens of Plastic Material**
- C5.2.6.1. **Resistance to Mechanical Deterioration of the Lens Surface**
- C5.2.6.1.1. Tests
Refer paragraph A5.2.6.1.1.
- C5.2.6.1.2. Results

After the test, the results of photometric measurements carried out on the lamp in accordance with this standard shall not exceed by more than 30 % the maximum values prescribed in zones A and B.
- C5.2.6.2. **Test of Adherence of Coatings, if any**
Refer paragraph A5.2.6.2
- C5.3 VERIFICATION OF THE CONFORMITY OF PRODUCTION**
Refer paragraphs A5.3.1, A5.3.1.1
- C5.3.1.2. After the test described in paragraph A5.2.6.1.1 the photometric values at the points of measurement considered in paragraph C5.2.6.1.2. are within the limits prescribed for conformity of production by this Standard.
- C5.3.2. If the test results fail to satisfy the requirements, the tests shall be repeated on another sample of front fog lamps selected at random

ANNEX:C 5 – APPENDIX:1
(See para C5.1)

CHRONOLOGICAL ORDER OF APPROVAL TESTS

Table A: Tests on plastic materials (lenses or samples of material supplied pursuant to paragraph 7.3 of this Standard).

Samples Test		Lenses or samples of material						Lenses						
		1	2	3	4	5	6	7	8	9	10	11	12	13
C5:App1.1.1	Limited Photometry (Para.C5.2.1.2)										x	x	x	
C5:App1.1.1.1	Temperature change (para. C5.2.1.1.)										x	x	x	
C5:App1.1.1.2.	Limited photometry (para. C5.2.1.2.)										x	x	x	
C5:App1.1.2.1	Transmission Measurement	x	x	x	x	x	x	x	x	x				
C5:App1.1.2.2.	Diffusion measurement	x	x	x				x	x	x				
C5:App1.1.3.	Atmospheric agents (para. C5.2.2.1.)	x	x	x										
C5:App1.1.3.1.	Transmission Measurement	x	x	x										
C5:App1.1.4.	Chemical agents (para.C5.2.2.2.)	x	x	x										
C5:App1.1.4.1.	Diffusion Measurement	x	x	x										
C5:App1.1.5.	Detergents (para. C5.2.3.1.)				x	x	x							
C5:App1.1.6.	Hydrocarbons (para. C5.2.3.2.)				x	x	x							
C5:App1.1.6.1.	Transmission measurement				x	x	x							
C5:App1.1.7.	Deterioration (para. C5.2.4.1.)							x	X	x				
C5:App1.1.7.1.	Transmission Measurement							x	X	x				
C5:App1.1.7.2.	Diffusion Measurement							x	X	x				
C5:App1.1.8.	Adherence (para.C5.2.5.)													x

Table B : Tests on complete front fog lamps (supplied pursuant to paragraph 7.3. of this Standard).

Tests		Complete front fog lamp	
		Sample No.	
		1	2
C5:App1.2.1.	Deterioration (para. C5.2.6.1.1.)	x	
C5:App1.2.2.	Photometry (para. C5.2.6.1.2.)	x	
C5:App1.2.3.	Adherence (para. C5.2.6.2.)		X

ANNEX:C5 – APPENDIX:2

**METHOD OF MEASUREMENT OF THE DIFFUSION
AND TRANSMISSION OF LIGHT**

Refer Annex : A5 – Appendix:2

ANNEX:C 5 – APPENDIX:3

SPRAY TESTING METHOD

Refer Annex : A5 – Appendix:3

ANNEX: C5 – APPENDIX:4

ADHESIVE TAPE ADHERENCE TEST

Refer Annex : A5 – Appendix:4

ANNEX: C 6
(See para 8.0)

**MINIMUM REQUIREMENTS FOR CONFORMITY OF
PRODUCTION CONTROL PROCEDURES**

C6.1. GENERAL

C6.1.1 The conformity requirements shall be considered satisfied from a mechanical and a geometrical standpoint, if the differences do not exceed inevitable manufacturing deviations within the requirements of this standard.

C6.1.2. With respect to photometric performances, the conformity of mass-produced front fog lamps shall not be contested if, when testing photometric performances of any front fog lamps chosen at random and equipped with a standard filament lamp:

No measured value deviates unfavourably by more than 20 per cent from the value prescribed in this standard (points B 50 and left and right bottom corners of Zone D)

If the results of the tests described above do not meet the requirements, tests on the front fog lamp shall be repeated using another standard filament lamp.

C6.1.3. With respect to the verification of the change in vertical position of the cut-off line under the influence of heat, the following procedure shall be applied:

One of the sampled front fog lamp shall be tested according to the procedure described in paragraph C4.2.1. of Annex:C4 after being subjected three consecutive times to the cycle described in paragraph C4.2.2.2. of Annex : C4

The front fog lamp shall be considered as acceptable if Δr does not exceed 3.0 mrad.

If this value exceeds 3.0 mrad but is not more than 4.0 mrad, a second front fog lamp shall be subjected to the test after which the mean of the absolute values recorded on both samples shall not exceed 3.0 mrad.

C6.1.4. The chromaticity coordinates shall be compiled with when the front fog lamp is equipped with a filament lamp set to Standard A colour temperature.

AIS-012

The photometric performance of a front fog lamp emitting an enlarged selective yellow light when equipped with colourless filament lamp shall be the values contained in this standard multiplied by 0.84.

C6.2. MINIMUM REQUIREMENTS FOR VERIFICATION OF CONFORMITY BY THE MANUFACTURER

For each type of front fog lamp the holder of the approval mark shall carry out at least the following tests, at appropriate intervals. The tests shall be carried out in accordance with the provision of this standard.

If any sampling shows non-conformity with regard to the type of test concerned, further samples shall be taken and tested. The manufacturer shall take steps to ensure the conformity of the production concerned.

C6.2.1. Nature of Tests

Tests of conformity in this standard shall cover the photometric characteristics and the verification of the change in vertical position of the cut-off line under the influence of heat.

C6.2.2. Methods used in Tests

A6.2.2.1. Tests shall generally be carried out in accordance with the methods set out in this standard

C6.2.2.2. In any test of conformity carried out by the manufacturer, equivalent methods may be used with the consent of the test agency responsible for approval tests. The manufacturer is responsible for proving that the applied methods are equivalent to those laid down in this standard.

C6.2.2.3. The application of paragraphs C6.2.2.1. and C6.2.2.2. requires regular calibration of test apparatus and its correlation with measurement made by a test agency

C6.2.2.4. In all cases the reference methods shall be those of this standard, particularly for the purpose of administrative verification and sampling.

C6.2.3. Nature of Sampling

Samples of front fog lamp shall be selected at random from the production of a uniform batch. A uniform batch means a set of front fog lamp of the same type, defined according to the production methods of the manufacturer.

AIS-012

The assessment shall, in general, cover series production from individual factories. However, a manufacturer may group together records concerning the same type from several factories provided these operate under the same quality system and quality management.

C6.2.4. Measured and Recorded Photometric Characteristics

The sampled front fog lamp shall be subjected to photometric measurements at the points provided for in the standard, the reading being limited at the points B 50 and left and right bottom corners of Zone D (See Figure: C1).

C6.2.5. Criteria Governing Acceptability

The manufacturer is responsible for carrying out a statistical study of the test results and for defining, in agreement with the test agency, criteria governing acceptability of his products in order to meet the specification laid down for verification of conformity of products in paragraph 8.1. of this standard.

The criteria governing acceptability shall be such that, with a confidence level of 95 per cent, the minimum probability of passing a spot check in accordance with Annex: C7 (first sampling) would be 0.95.

ANNEX: C7

(See para 8.0)

**MINIMUM REQUIREMENTS FOR SAMPLING BY
AN INSPECTOR**

C7.1. GENERAL

C7.1.1. The conformity requirements shall be considered satisfied from a mechanical and a geometrical standpoint in accordance with the requirements of this standard, if any, if the differences do not exceed inevitable manufacturing deviations.

C7.1.2. With respect to photometric performances, the conformity of mass-produced front fog lamps shall not be contested if, when testing photometric performances of any front fog lamp chosen at random and equipped with a standard filament lamp

no measured value deviates unfavorably by more than 20 per cent from the value prescribed in this standard (Points B 50 and left and right bottom corners of Zone D)

C7.1.2.1. If the results of the tests described above do not meet the requirements, tests shall be repeated using another standard filament lamp.

C7.1.2.2. Front fog lamps with apparent defects are disregarded.

C7.1.3 The chromaticity coordinates shall be complied with when the front fog lamp is equipped with a filament lamp set to standard A colour temperature

The photometric performance of a front fog lamp emitting enlarged selective yellow light when equipped with a colorless filament lamp shall be multiplied by 0.84.

C7.2. FIRST SAMPLING

In the first sampling four front fog lamps are selected at random. The first sample of two is marked A, the second sample of two is marked B.

C7.2.1. The Conformity is Not Contested

C7.2.1.1. Following the sampling procedure shown in Figure : A3 of relevant Annex of mass-produced front fog lamps shall not be contested if the deviations of the measured values of the front fog lamps in the unfavourable directions are:

C7.2.1.1.1. **Sample A**

A1:	one front fog lamp		0 %
	one front fog lamp	not more than	20%
A2:	both front fog lamps	more than	0 %
	But	not more than	20%
	go to sample B		

C7.2.1.1.2. **Sample B**

B1:	Both front fog lamps		0 %
-----	----------------------	--	-----

C7.2.2. **The Conformity is Contested**

C7.2.2.1. Following the sampling procedure shown in Figure : A3 of relevant Annex the conformity of mass-produced front fog lamps shall be contested and the manufacturer requested to make his production meet the requirements (alignment) if the deviations of the measured values of the front fog lamps are:

C7.2.2.1.1. **Sample A**

A3:	one front fog lamp	not more than	20%
	one front fog lamp	more than	20%
	but	not more than	30%

C7.2.2.1.2. **Sample B**

B2:	in the case of A2		
	one front fog lamp	more than	0%
	But	not more than	20%
	one front fog lamp	not more than	20%
B3:	in the case of A2		
	one front fog lamp		0%
	one front fog lamp	more than	20%
	but	not more than	30%

C7.2.3. **Approval Withdrawn**

Conformity shall be contested and paragraph 8.3 of this standard applied if, following the sampling procedure shown in Figure: A3 of relevant Annex the deviations of the measured values of the front fog lamps are:

C7.2.3.1. **Sample A**

A4:	one front fog lamp	not more than	20%
	one front fog lamp	more than	30%
A5:	Both front fog lamps	more than	20%

C7.2.3.2. **Sample B**

B4:	in the case of A2		
	one front fog lamp	more than	0%
	but	not more than	20%
	one front fog lamp	more than	20%
B5:	in the case of A2		
	both front fog lamps	more than	20%
B6:	in the case of A2		
	one front fog lamp		0%
	one front fog lamp	more than	30%

C7.3. REPEATED SAMPLING

In the case of A3, B2, B3 a repeated sampling, third sample C of two front fog lamps, and fourth sample D of two front fog lamps, selected from stock manufactured after alignment, is necessary within two months' time after the notification.

C7.3.1. **The Conformity is Not Contested**

C7.3.1.1. Following the sampling procedure shown in Figure: A3 of relevant Annex the conformity of mass-produced front fog lamps shall not be contested if the deviations of the measured values of the front fog lamps are:

C7.3.1.1.1. **Sample C**

C1:	one front fog lamp		0%
	one front fog lamp	not more than	20%
C2:	both front fog lamps	more than	0%
	but	not more than	20%
	go to sample D		

C7.3.1.1.2. **Sample D**

D1:	in the case of C2		
	both front fog lamps		0%

C7.3.2. The Conformity is Contested

C7.3.2.1. Following the sampling procedure shown in Figure : A3 of relevant Annex the conformity of mass-produced front fog lamps shall be contested and the manufacturer requested to make his production meet the requirements (alignment) if the deviations of the measured values of the front fog lamps are:

C7.3.2.1.1. Sample D

D2:	in the case of C2		
	one front fog lamp	more than	0%
	But	not more than	20%
	one front fog lamp	not more than	20%

C7.3.3. Approval Withdrawn

Conformity shall be contested and paragraph 8.3 of this standard applied if, following the sampling procedure shown in Figure: A3 of relevant Annex, the deviations of the measured values of the front fog lamps are:

C7.3.3.1. Sample C

C3:	one front fog lamp	not more than	20%
	one front fog lamp	more than	20%
C4:	both front fog lamps	more than	20%

C7.3.3.2. Sample D

D3:	in the case of C2		
	one front fog lamp	0 or more than	0%
	one front fog lamp	more than	20%

C7.4. CHANGE OF THE VERTICAL POSITION OF THE CUT-OFF LINE

With respect to the verification of the change in vertical position of the cut-off line under the influence of heat, the following procedure shall be applied:

One of the front fog lamps of sample A after sampling procedure in Figure : M1 shall be tested according to the procedure described in paragraph C4.2.1. of Annex : C4 after being subjected three consecutive times to the cycle described in paragraph C4.2.2.2. of Annex C4.

AIS-012

The front fog lamp shall be considered as acceptable if Δr does not exceed 3.0 mrad.

If this value exceeds 3.0 mrad but is not more than 4.0 mrad, the second front fog lamp of sample A shall be subjected to the test after which the mean of the absolute values recorded on both samples shall not exceed 3.0 mrad.

However, if this value of 3.0 mrad on sample A is not complied with, the two front fog lamps of sample B shall be subjected to the same procedure and the value of Δr for each of them shall not exceed 3.0 mrad.

ANNEX : D1
(See para 5.4)

**REQUIREMENTS FOR FRONT AND REAR POSITION
(SIDE) LAMPS, STOP LAMPS AND
END-OUTLINE MARKER LAMPS**

D1.1 GENERAL SPECIFICATIONS

- D1.1.1 Each device supplied shall conform to the specifications set forth in Annex : D1,D2, D3 and Annex :L
- D1.1.2 The devices shall be so designed and constructed that in normal conditions of use, and not withstanding the vibrations to which they may be subjected in such use, their satisfactory operation remains assured and they retain the characteristics prescribed by this standard.
- D1.1.3 Lamps having been approved as front or rear position (side) lamps, are deemed being also approved end-outline marker lamps.
- D1.1.4 Front and rear position (side) lamps which are grouped or combined or reciprocally incorporated may also be used as end-outline marker lamps.
- D1.1.5 Position (side) lamps, which are reciprocally incorporated with another function, using a common light source, and designed to operate permanently with an additional system to regulate the intensity of the light emitted, are permitted.
- D1.1.5.1 However, in the case of rear (side) position lamp reciprocally incorporated with a stop lamp, the device shall either:
(i) be a part of a multiple light source arrangement, or
(ii) be intended for use in a vehicle equipped with a failure monitoring system for that function.
In either case, a note shall be made within the technical information to be submitted by the manufacturer.

ANNEX : D2
(See para 5.4 and D1.1.1.)

**PHOTOMETRIC TEST PROCEDURE AND
INTENSITY REQUIREMENTS FOR FRONT AND
REAR POSITION (SIDE) LAMPS,
STOP LAMPS AND END-OUTLINE MARKER LAMPS**

D2.1 INTENSITY OF LIGHT EMITTED

D2.1.1. In the reference axis, the light emitted by each of the two devices supplied must be of not less than the minimum intensity and of not more than the maximum intensity specified below:

(1)		Minimum Intensities cd	Maximum values in cd when used as		
			Single lamp	Lamp (single) marked 'D' ⁽³⁾	Total for the assembly of two or more lamps
D2.1.1.1	Front position (side) lamps, front end-outline marker lamp	4	60 ⁽²⁾	42 ⁽²⁾	84 ⁽²⁾
D2.1.1.2	Front position (side) lamps, incorporated in headlamps	4	100 ⁽²⁾	-	-
D2.1.1.3	Rear position (side) lamps, rear end-outline marker lamp	4	12 ⁽²⁾	8.5 ⁽²⁾	17 ⁽²⁾
D2.1.1.4	Stop-lamps				
D2.1.1.4.1	With 1 level of intensity (Category S1)	60	185 ⁽²⁾	130 ⁽²⁾	260 ⁽²⁾
D2.1.1.4.2	With 2 levels of intensity (Category S2)				
D2.1.1.4.2.1	by day	130	520 ⁽²⁾	366 ⁽²⁾	728 ⁽²⁾
D2.1.1.4.2.2	by night	30	80 ⁽²⁾	56 ⁽²⁾	112 ⁽²⁾
D2.1.1.4.3	stop-lamps of Category S3	25	80 ⁽²⁾	55 ⁽²⁾	110 ⁽²⁾

Note : For Foot-notes (1), (2), and (3) see next page

AIS-012

- D2.1.2. Outside the reference axis and within the angular fields defined in the diagrams Annex : D2 – Appendix 1, the intensity of the light emitted by each of the two devices supplied shall:
- D2.1.2.1. In each direction corresponding to the points in the light distribution table reproduced in Annex : D2 – Appendix 2 (Table : D1 ,D2), be not less than the product of the minimum specified in paragraph D2.1. above by the percentage specified in the said table of the direction in question. (Tables : D3, D4 give required intensity values)
- D2.1.2.2. In no direction within the space from which the light-signalling device is visible, exceed the maximum specified in paragraph D2.1. above;
- D2.1.2.3. However, a luminous intensity of 60 cd shall be permitted for rear position (side) lamps reciprocally incorporated with stop-lamps (see paragraph D2.1.1.3. above) below a plane forming an angle of 5° with and downward from the horizontal plane;
- D2.1.2.4. Moreover,
- D2.1.2.4.1. Throughout the fields defined in the diagrams in Annex D2 – Appendix 1, the intensity of the light emitted shall be not less than 0.05 cd for front and rear position (side) lamps and end outline marker lamps, not less than 0.3 cd for stop-lamps with one level of intensity, and for stop-lamps with two levels of intensity 0.3 cd by day and 0.07 cd by night;

-
- (1) The installation of the devices referred to above in power-driven vehicles and their trailers is provided for in the standard concerning the installation of lighting and light-signalling devices (AIS-008).
- (2) The total value of maximum intensity for an assembly of two or more lamps is given by multiplying by 1.4 the value prescribed for a single lamp. When an assembly of two or more lamps having the same function is deemed to be, for the purpose of installation on a vehicle, a "single lamp" (following the definition of AIS-008 and its amendments in force at the time of application for type approval), this assembly shall comply with the minimum intensity required when one lamp has failed, and all the lamps together shall not exceed the admissible maximum intensity (last column of the table).
- In the case of a single lamp containing more than one light source:
- (i) all light sources which are connected in series are considered to be one light source;
 - (ii) the lamp shall comply with the minimum intensity required when any one light source has failed. However, for lamps designed for only two light sources, 50 per cent of the minimum intensity in the axis of reference of the lamp shall be considered sufficient, provided that a note in the technical information to be submitted by manufacturer shall states that the lamp is only for use on a vehicle fitted with an operating tell-tale which indicates when any one of these two light sources has failed.
 - (iii) when all light sources are illuminated the maximum intensity specified for a single lamp may be exceeded provided that the single lamp is not marked "D" and the maximum intensity specified for an assembly of two or more lamps (last column of the table) is not exceeded.
- (3) Devices which may be used as part of an assembly of two lamps

AIS-012

- D2.1.2.4.2. If a rear position (side) lamp is reciprocally incorporated with a stop-lamp, the ratio between the luminous intensities actually measured of the two lamps when turned on simultaneously at the intensity of the rear position (side) lamp when turned on alone should be at least 5 : 1 in the field delimited by the straight horizontal lines passing through $\pm 5^\circ$ V and the straight vertical lines passing through $\pm 10^\circ$ H of the light distribution table. If the stop-lamp has two levels of intensity, this requirement must be satisfied when the night condition is switched on; If the rear position (side) lamp or the stop lamp or both contain more than one light source and are considered as a single lamp as defined in note ⁽²⁾ of the table in paragraph D2.1.1 above, the values to be considered are those obtained with all sources in operation;
- D2.1.2.4.3. The provisions of paragraph D2:APP.2.2.2 of Annex : D2 – Appendix 2 on local variations of intensity must be observed.
- D2.1.3. The intensities shall be measured with the filament lamp(s) continuously alight and, in the case of devices emitting selective-yellow or red light, in coloured light.
- D2.1.4. In the case of a stop-lamp providing two levels of intensity, the time that elapses between electrical supply being switched on and the light output measured on the reference axis to reach 90% of the value measured in accordance with paragraph D2.1.3 above shall be measured for both the day and the night conditions of use. The time measured for the night condition of use shall not exceed that measured for the day condition of use.
- D2.1.5 Annex : D2 – Appendix 2 to which reference is made in paragraph D2.1.2.1. above, gives particulars of the methods of measurement to be used.

D2.2 TEST PROCEDURE

- D2.2.1. All measurements, photometric and colorimetric, shall be made with a colourless standard filament lamp of the category prescribed for the device, the supply voltage being so regulated as to produce the reference luminous flux required for that category of lamp.
- D2.2.1.1 In the case of a system with more than one intensity, the reference luminous flux prescribed for the specific category of filament lamp shall be applied to the greatest intensity.
- D2.2.1.2. All measurements, photometric and colorimetric, on lamps equipped with non-replaceable light sources (filament lamps and others) shall be made at 6.75 V, 13.5 V or 28.0 V, respectively.

AIS-012

- D2.2.1.3. In the case of light sources supplied by a special power supply, the above test voltages shall be applied to the input terminals of that power supply. The test laboratory may require from the manufacturer the special power supply needed to supply the light sources.
- D2.2.2. However, in the case of a stop-lamp for which an additional system is used to obtain the night-time intensity, the voltage applied to the system for measuring the night-time intensity shall be that which was applied to the filament lamp for measuring the day-time intensity⁽¹⁾
- D2.2.3. Where a rear position (side) lamp is reciprocally incorporated with a dual-intensity stop lamp and is designed to operate permanently with an additional system to regulate the intensity of the light emitted, measurement of the light emitted shall be performed with the same voltage applied to the system as would, if applied to the filament lamp, enable the lamp to produce the prescribed normal luminous flux.
- D2.2.3.1 Where a position (side) lamp is reciprocally incorporated with another lamp, and is designed to operate permanently with an additional system to regulate the intensity of the light emitted, measurement of the light emitted shall be performed at 6,75 V, 13.5 V or 28 V respectively, where the additional system is part of the device.
- D2.2.3.2. Where the additional system is not part of the device, then the tests shall be performed at the rated secondary design voltage applied to the light source. The test laboratory may require from the manufacturer the additional system needed to regulate the light source.
- D2.2.4. The vertical and horizontal outlines of the illuminating surface of a light-signalling device shall be determined and measured in relation to the centre of reference.
- D2.2.5. In the case of a category S3 stop lamp, which is intended to be mounted inside the vehicle, a sample plate or sample plates (in case of different possibilities) as supplied (see relevant para of Table 2 of this standard) shall be positioned in front of the lamp to be tested, in the geometrical position(s) as described in the application drawing(s) (see relevant para of Table 2 of this standard).

(1) The functioning and installation conditions of these additional systems will be defined by special provisions.

ANNEX : D 2 – APPENDIX 1

(See para D2.1.2)

FRONT AND REAR POSITION (SIDE) LAMPS, END-OUTLINE MARKER LAMPS AND STOP LAMPS

MINIMUM ANGLES REQUIRED FOR LIGHT DISTRIBUTION IN SPACE OF THESE LAMPS ⁽¹⁾

In all cases, the minimum vertical angles of light distribution in space are 15° above and 15° below the horizontal for all categories of devices included in this Regulation, except:

- (a) for lamps with a permissible mounting height < 750 mm above the ground, for which they are 15° above and 5° below the horizontal;
- (b) for category S3 stop lamp for which they are 10° above and 5° below the horizontal;

Minimum horizontal angles of light distribution in space

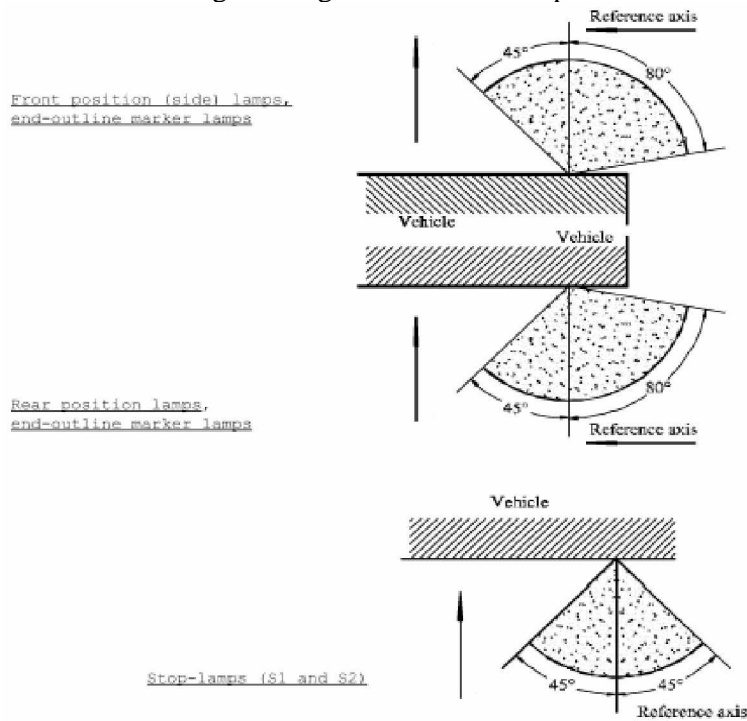

Stop lamp S3

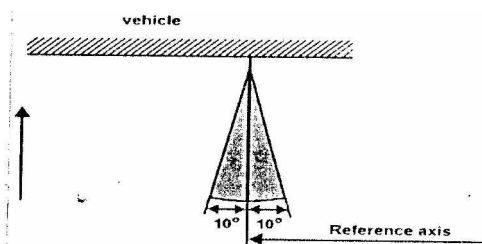

(1) The angles shown in these diagrams are correct for devices to be mounted on the right side of the vehicle . The arrows point to the front of the vehicles

ANNEX : D2 – APPENDIX 2
(See para. D2.1.2.1)

PHOTOMETRIC MEASUREMENTS

D2.APP.2.1. MEASUREMENT METHODS

- D2.App.2.1.1 During photometric measurements, stray reflections shall be avoided by appropriate masking.
- D2.App.2.1.2. In case the results of measurements should be challenged, measurements shall be carried out in such a way as to meet the following requirements:
 - D2.App.2.1.2.1 The distance of measurement shall be such that the law of the inverse of the square of the distance is applicable;
 - D2.App.2.1.2.2. The measuring equipment shall be such that the angular aperture of the receiver viewed from the reference centre of the lamp is comprised between 10 angular minutes and one degree;
 - D2.App.2.1.2.3. The intensity requirement for a particular direction of observation shall be deemed to be satisfied if that requirement is met in a direction deviating by not more than one-quarter of a degree from the direction of observation.
- D2.App.2.1.3. In the case where the device may be installed on the vehicle in more than one or in a field of different positions the photometric measurements shall be repeated for each position or for the extreme positions of the field of the reference axis specified by the manufacturer.

Table : D1
(See para. D2.1.2.1)

D2.APP.2.2. STANDARD LIGHT DISTRIBUTION

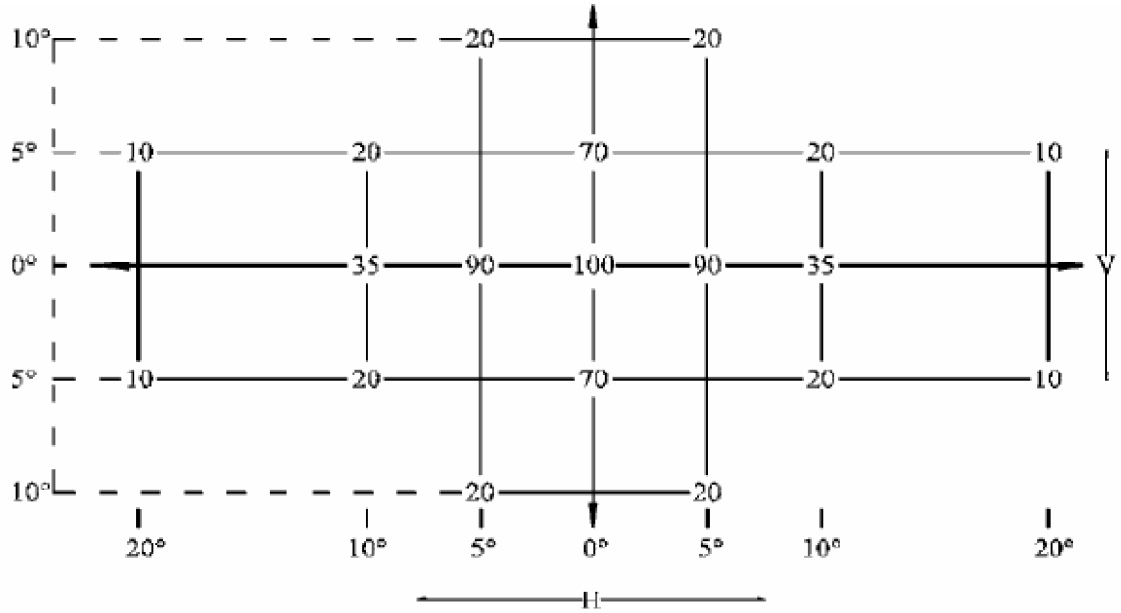

Table : D2
(See para. D2.1.2.1)

Table of light distribution for category S3 stop-lamp

10°	32	-	64	-	32
5°	64	100	100	100	64
0°	64	100	100	100	64
5°	64	100	100	100	64
	10°	5°	0°	5°	10°

TABLE : D3
(See para D2.1.2.1)
INTENSITY VALUES IN CANDELAS
FOR POSITION (SIDE) LAMP, END-OUTLINE MARKER LAMP

Test Points V° H°		Position (Side) lamp and End - out linemarker lamp			
		Front facing		Rear facing	
		Min.	Max ⁽¹⁾	Min.	Max.
(1)	(2)	(3)	(4)	(5)	(6)
15 U	V	0.05	60	0.05	12
10 U	5 L	0.8	60	0.8	12
10 U	5 R	0.8	60	0.8	12
5 U	20 L	0.4	60	0.4	12
5 U	10 L	0.8	60	0.8	12
5 U	V	2.8	60	2.8	12
5 U	10 R	0.8	60	0.8	12
5 U	20 R	0.4	60	0.4	12
H	80 L	0.05	60	0.05	12
H	45 L	0.05	60	0.05	12
H	10 L	1.4	60	1.4	12
H	5 L	3.6	60	3.6	12
H	V	4.0	60 ¹	4.0	12
H	5 R	3.6	60	3.6	12
H	10 R	1.4	60	1.4	12
H	45 R	0.05	60	0.05	12
H	80 R	0.05	60	0.05	12
5 D	20 L	0.4	60	0.4	12
5 D	10 L	0.8	60	0.8	12
5 D	V	2.8	60	2.8	12
5 D	10 R	0.8	60	0.8	12
5 D	20 R	0.4	60	0.4	12
10 D	5 L	0.8	60	0.8	12
10 D	5 R	0.8	60	0.8	12
15 D	V	0.05	60	0.05	12

Note to table :

(1) For front position lamp when incorporated in head lamp
max. 100 cd.

TABLE : D4
(See para. D2.1.2.1)
INTENSITY VALUES IN CANDELAS FOR STOP LAMP

Test Points V° H°		Stop Lamp Categories							
		S1		S2				S3	
				By Day		By Night			
		Min	Max.	Min.	Max.	Min.	Max.	Min.	Max.
(1)	(2)	(3)	(4)	(5)	(6)	(7)	(8)	(9)	(10)
15 U	V	0.3	185	0.3	520	0.07	80	-	-
10 U	10 L	-	185	-	520	-	80	8	80
10 U	5 L	12.0	185	26	520	6	80	-	80
10 U	V	-	185	-	520	-	80	16	80
10 U	5 R	12.0	185	26	520	6	80	-	80
10 U	10 R	-	185	-	520	-	80	8	80
5 U	20 L	6.0	185	13	520	3	80	-	--
5 U	10 L	12.0	185	26	520	6	80	16	80
5 U	5 L	-	185	-	520	-	80	25	80
5 U	V	42.0	185	91	520	21	80	25	80
5 U	5 R	-	185	-	520	-	80	25	80
5 U	10 R	12.0	185	26	520	6	80	16	80
5 U	20 R	6.0	185	13	520	3	80	-	--
H	80 L	-	185	-	520	-	80	-	-
H	45 L	0.3	185	0.3	520	0.07	80	-	-
H	10 L	21.0	185	45.5	520	10.5	80	16	80
H	5 L	54.0	185	117	520	27	80	25	80
H	V	60.0	185	130	520	30	80	25	80
H	5 R	54.0	185	117	520	27	80	25	80
H	10 R	21.0	185	45.5	520	10.5	80	16	80
H	45 R	0.3	185	0.3	520	0.07	80	-	-
H	80 R	-	185	-	520	-	80	-	-
5 D	20 L	6.0	185	13	520	3	80	-	-
5 D	10 L	12.0	185	26	520	6	80	16	80
5 D	5 L	-	185	-	520	-	80	25	80
5 D	V	42.0	185	91	520	21	80	25	80
5 D	5 R	-	185	-	520	-	80	25	80
5 D	10 R	12.0	185	26	520	6	80	16	80
5 D	20 R	6.0	185	13	520	3	80	-	-
10 D	5 L	12.0	185	26	520	6	80	-	-
10 D	5 R	12.0	185	26	520	6	80	-	-
15 D	V	0.3	185	0.3	520	0.07	80	-	-

- D2.App.2.2.1. The direction $H = 0$ degrees and $V = 0$ degrees corresponds to the reference axis. (On the vehicle it is horizontal, parallel to the median longitudinal plane of the vehicle and oriented in the required direction of visibility.) It passes through the centre of reference. The values shown in the table give, for the various directions of measurement, the minimum intensities as a percentage of the minimum required in the axis for each lamp (in the direction $H = 0$ degrees and $V = 0$ degrees).
- D2.App.2.2.2. Within the field of light distribution of paragraph D2.App.2.2., schematically shown as a grid, the light pattern should be substantially uniform, i.e. the light intensity in each direction of a part of the field formed by the grid lines shall meet at least the lowest minimum value being shown on the grid lines surrounding the questioned direction as a percentage.
- D2.App.2.2.3. However, in the case where a device is intended to be installed at a mounting height of equal to or less than 750 mm above the ground, the photometric intensity is verified only up to an angle of 5 degrees downwards.

D2.App.2.3. Photometric measurement of lamps

The photometric performance shall be checked:

- D2.App.2.3.1. For non-replaceable light sources (filament lamps and other):
with the light sources present in the lamp, in accordance with paragraph D2.2.1.1. of Annex :D2.
- D2.App.2.3.2. For replaceable filament lamps:
when equipped with filament lamps at 6.75 V, 13.5 V or 28.0 V the luminous intensity values produced shall be corrected. The correction factor is the ratio between the reference luminous flux and the mean value of the luminous flux found at the voltage applied (6.75 V, 13.5 V or 28.0 V). The actual luminous fluxes of each filament lamp used shall not deviate more than $\pm 5\%$ from the mean value. Alternatively a standard filament lamp may be used in turn, in each of the individual positions, operated at its reference flux, the individual measurements in each position being added together.
- D2.App.2.3.3. For any signaling lamp except those equipped with filament lamp(s), the luminous intensities, measured after one minute and after 30 minutes of operation, shall comply with the minimum and maximum requirements. The luminous intensity distribution after one minute of operation can be calculated from the luminous intensity distribution after 30 minutes of operation by applying at each test point the ratio of luminous intensities measured at HV after one minute and after 30 minutes of operation.

ANNEX : D3
(See para 5.4 and D1.1.1)

COLOUR OF LIGHT EMITTED

D3.1 The colour of the light emitted inside the field of the light distribution grid defined in paragraph D2.App2.2 of Annex : D2 – Appendix 2 shall be within the limits of the coordinates prescribed in para D3.2 of this Annex : D3 given below. Outside this field, no sharp variation of colour shall be observed.

D3.2 TRICHROMATIC COORDINATES

RED	:	Limit towards yellow	: $y \leq 0.335$
		Limit towards purple	: $z \leq 0.008$ or : $y \geq 0.980-x$
WHITE	:	Limit towards blue	: $x \geq 0.310$
		Limit towards yellow	: $x \leq 0.500$
		Limit towards green	: $y \leq 0.150 + 0.640x$
		Limit towards green	: $y \leq 0.440$
		Limit towards purple	: $y \geq 0.050 + 0.750x$
		Limit towards red	: $y \geq 0.382$
SELECTIVE-YELLOW	:	Limit towards red	: $y \geq 0.138 + 0.580x$
		Limit towards green	: $y \leq 1.29x - 0.100$
		Limit towards white	: $y \geq -x + 0.966$
		Limit towards spectral value	: $y \leq -x + 0.992$

For checking these colorimetric characteristics, a source of light at a colour temperature of 2,856 K corresponding to illuminant A of the International Commission on Illumination (CIE) shall be used. However, for lamps equipped with non-replaceable light sources (filament lamps and other), the colorimetric characteristics should be verified with the light sources present in the lamp, in accordance with paragraph D2.2.1.1. of Annex : D2.

In the case of a category S3 stop lamp, which is intended to be mounted inside the vehicle, the colorimetric characteristics shall be verified with the worst case combination(s) of lamp and rear window(s) or sample plate(s).

ANNEX: D4
(See Para 8.0)

**MINIMUM REQUIREMENTS FOR
CONFORMITY OF PRODUCTION
CONTROL PROCEDURES**

D4.1. GENERAL

D4.1.1 The conformity requirements shall be considered satisfied from a mechanical and a geometrical standpoint, if the differences do not exceed inevitable manufacturing deviations within the requirements of this standard.

D4.1.2 With respect to photometric performances, the conformity of mass-produced lamps shall not be contested if, when testing photometric performances of any lamp chosen at random and equipped with a standard filament lamp, or when the lamps are equipped with non-replaceable light sources (filament lamps or other), and when all measurements are made at 6.75V, 13.5V or 28.0V respectively.

D4.1.2.1. No measured value deviates unfavourably by more than 20% from the values prescribed in this standard.

D4.1.2.2. If, in the case of a lamp equipped with a replaceable light source and if results of the test described above do not meet the requirements, tests on lamps shall be repeated using another standard filament lamp.

D4.1.3 The chromaticity coordinates shall be complied with when the lamp is equipped with a standard filament lamp, or for lamps equipped with non-replaceable light sources (filament lamps or other), when the colorimetric characteristics are verified with the light source present in the lamp.

**D4.2. MINIMUM REQUIREMENTS FOR VERIFICATION OF
CONFORMITY BY THE MANUFACTURER**

Refer para A6.2 of Annex : A6 with replacing word “lamp” for “headlamp” wherever it appears.

D4.2.1. Nature of Tests

Tests of conformity in this standard shall cover the photometric and colorimetric characteristics.

D4.2.2. Methods used in Tests

Refer paragraph A6.2.2 of Annex : A6

D4.2.3. Nature of Sampling

Refer paragraph A6.2.3. of Annex : A6 with replacement of word “lamp” for “head lamp” wherever it appears.

D4.2.4. Measured and Recorded Photometric Characteristics

The sampled lamp shall be subjected to photometric measurements for the minimum values at the points listed in Annex : D2, Appendix – 2 and the chromaticity coordinates in para. D3.2 of Annex : D3 provided for in the relevant Annex

D4.2.5. Criteria Governing Acceptability

The manufacturer is responsible for carrying out a statistical study of the test results and for defining, in agreement with the test agency, criteria governing acceptability of his products in order to meet the specification laid down for verification of conformity of products in paragraph 8.1 of this standard.

The criteria governing acceptability shall be such that, with a confidence level of 95%, the minimum probability of passing a spot check in accordance with Annex : D5 (first sampling) would be 0.95.

ANNEX: D5

(See para 8.0 and D4.2.5 of Annex : D4)

**MINIMUM REQUIREMENTS FOR SAMPLING BY
AN INSPECTOR****D5.1. GENERAL**

- D5.1.1. The conformity requirements shall be considered satisfied from a mechanical and a geometrical standpoint in accordance with the requirements of this standard, if any, if the differences do not exceed inevitable manufacturing deviations.
- D5.1.2. With respect to photometric performance, the conformity of mass-produced lamps shall not be contested if, when testing photometric performances of any lamp chosen at random and equipped with a standard filament lamp, or when the lamps are equipped with non-replaceable light sources (filament lamps or other), and when all measurements are made at 6.75V, 13.5V or 28.0V respectively.
- D5.1.2.1. No measured value deviates unfavorably by more than 20% from the values prescribed in this standard.
- D5.1.2.2. If, in the case of a lamp equipped with a replaceable light source and if results of the test described above do not meet the requirements, test on lamps shall be repeated using another standard filament lamp.
- D5.1.2.3. Lamps with apparent defects are disregarded
- D5.1.3. The chromaticity coordinates shall be complied with then the lamp is equipped with a standard filament lamp, or for lamps equipped with non-replaceable light sources (filament lamps or other), when the colorimetric characteristics are verified with the light source present in the lamp.

D5.2. FIRST SAMPLING

Refer paragraph A7.2 of Annex : A7 with replacing word “lamp” for “headlamp” wherever it appears.

D5.2.1. The Conformity is Not Contested.

- D5.2.1.1. Refer paragraph A7.2.1.1. of Annex : A7 with replacing word “lamp” for “headlamp” wherever it appears.
- D5.2.1.1.1. Refer paragraph A7.2.1.1.1. of Annex : A7 with replacing word “lamp” for “headlamp” wherever it appears.

D5.2.1.1.2. **Sample B**

B1:	Both lamp		0 %
-----	-----------	--	-----

5.2.1.2. or if the conditions of paragraph D5.1.2.2. for Sample A are fulfilled.

D5.2.2. **The Conformity is Contested**

D5.2.2.1 Refer paragraph A7.2.2.1. of Annex : A7 with replacing word “lamp” for “headlamp” wherever it appears.

D5.2.2.1.1. Refer paragraph A7.2.2.1.1. of Annex : A7 with replacing word “lamp” for “headlamp” wherever it appears.

D5.2.2.1.2. **Sample B**

Refer paragraph A7.2.2.1.2. of Annex : A7 with replacing word “lamp” for “headlamp” wherever it appears.

D5.2.2.2. or if the conditions of paragraph D5.1.2.2. for sample A are not fulfilled.

D5.2.3. **Approval Withdrawn**

Refer paragraph A7.2.3. of Annex : A7 with replacing word “lamp” for “headlamp” wherever it appears.

D5.2.3.1. **Sample A**

Refer paragraph A7.2.3.1. of Annex : A7 with replacing word “lamp” for “headlamp” wherever it appears.

D5.2.3.2. **Sample B**

Refer paragraph A7.2.3.2. of Annex : A7 with replacing word “lamp” for “headlamp” wherever it appears.

D5.2.3.3. or if the conditions of paragraph D5.1.2.2. for samples A and B are not fulfilled.

D5.3. Repeated Sampling

Refer paragraph A7.3 of Annex : A7 with replacing word “lamp” for “headlamp” wherever it appears.

D5.3.1. The Conformity is Not Contested

D5.3.1.1. Refer paragraph A7.3.1.1 of Annex : A7 with replacing word “lamp” for “headlamp” wherever it appears.

D5.3.1.1.1. Sample C

Refer paragraph A7.3.1.1.1. of Annex : A7 with replacing word “lamp” for “headlamp” wherever it appears.

D5.3.1.1.2. Sample D

D1:	in the case of C2		
	both headlamps		0%

D5.3.1.2. or if the conditions of paragraph D5.1.2.2. for sample C are fulfilled.

D5.3.2. The Conformity is Contested

D5.3.2.1. Refer paragraph A7.3.2.1. of Annex : A7 with replacing word “lamp” for “headlamp” wherever it appears.

D5.3.2.1.1. Sample D

Refer paragraph A7.3.2.1.1. of Annex : A7 with replacing word “lamp” for “headlamp” wherever it appears.

D5.3.2.1.2. or if the conditions of paragraph D5.1.2.2 for sample C are not fulfilled.

D5.3.3. Approval Withdrawn

Refer paragraph A7.3.3. of Annex : A7 with replacing word “lamp” for “headlamp” wherever it appears.

D5.3.3.1. Sample C

Refer paragraph A7.3.3.1. of Annex : A7 with replacing word “lamp” for “headlamp” wherever it appears.

D5.3.3.2. Sample D

Refer paragraph A7.3.3.2. of Annex : A7 with replacing word “lamp” for “headlamp” wherever it appears.

D5.3.3.3. or if the conditions of paragraph D5.1.2.2. for samples C and D are not fulfilled.

ANNEX: E1
(See para 5.5)

REQUIREMENTS FOR DIRECTION INDICATORS

E1.1 GENERAL SPECIFICATIONS

- E1.1.1. Each device supplied shall conform to the specifications set forth in Annexes : E1,E2,E3 and Annex :L.
- E1.1.2. The devices must be so designed and constructed that under normal conditions of use and notwithstanding the vibrations to which they may be subjected in such use, their satisfactory operation remains assured and they retain the characteristics prescribed by this standard.

ANNEX: E2
(See para E1.1.1)

**PHOTOMETRIC TEST PROCEDURE AND INTENSITY
REQUIREMENTS FOR DIRECTION INDICATORS**

E2.1 INTENSITY OF LIGHT EMITTED

E2.1.1. The light emitted by each of the two devices supplied must be in the case of direction indicators of categories 1, 1a, 1b, 2a, 2b, 3 or 4 in the reference axes, in the case of direction indicators of categories 5 or 6 in direction A according to Annex:E2-Appendix-1 of not less than the minimum intensity and of not more than the maximum intensity specified below:

Direction indicator ⁽¹⁾ of category	Minimum intensities Cd	Maximum values in cd when used as		
		Single lamp	Lamp (single) marked D ⁽³⁾	Total for the assembly of two lamps ⁽³⁾
1	175	700 ⁽²⁾	490 ⁽²⁾	980 ⁽²⁾
1a	250	800 ⁽²⁾	560 ⁽²⁾	1,120 ⁽²⁾
1b	400	860 ⁽²⁾	600 ⁽²⁾	1,200 ⁽²⁾
2a	50	350	350	350
2b by day	175	700 ⁽²⁾	490 ⁽²⁾	980 ⁽²⁾
by night	40	120 ⁽²⁾	84 ⁽²⁾	168 ⁽²⁾
3 towards the front	175	700 ⁽²⁾	490 ⁽²⁾	980 ⁽²⁾
towards the rear	50	200	140	280
4 towards the front	175	700 ⁽²⁾	490 ⁽²⁾	980 ⁽²⁾
towards the rear	0.6	200	140	280
5	0.6	200	140	280
6	50	200	140	280

(1) The installation of front direction indicators of the various categories in power-driven vehicles and their trailers is provided for in the standard concerning the installation of lighting and light-signaling devices (AIS-008/2001)

(2) The total value of maximum intensity for an assembly of two or more lamps is given by multiplying by 1.4 the value prescribed for a single lamp, except for category 2a. When an assembly of two or more lamps having the same function is deemed to be, for the purpose of installation on a vehicle, a "single lamp" (following the definition of AIS - 008 and its amendments in force at the time of application for type approval), this assembly shall comply with the minimum intensity required when one lamp has failed, and, all the lamps together shall not exceed the admissible maximum intensity (last column of the table).

In the case of a single lamp containing more than one light source:

- (i) all light sources which are connected in series are considered to be one light source;
- (ii) the lamp shall comply with the minimum intensity required when any one light source has failed. However, for front or rear direction indicator lamps designed for only two light sources, 50 % of the minimum intensity in the axis of reference of the lamp shall be considered sufficient, provided that a note in the communication form states that the lamp is only for use on a vehicle fitted with an operating tell-tale which indicates when any one of these two light sources has failed.
- (iii) when all light sources are illuminated the maximum intensity specified for a single lamp may be exceeded provided that the single lamp is not marked "D" and the maximum intensity specified for an assembly of two or more lamps (last column of the table) is not exceeded.

(2) Devices which may be used as part of an assembly of two lamps

- E2.1.2 Outside the reference axis, within the angular fields specified in the arrangement diagrams in Appendix : 1 to this Annex : E2, the intensity of the light emitted by each of the two devices supplied must:
- E2.1.2.1. In each direction corresponding to the points in the relevant table of luminous-intensity distribution reproduced in Appendix : 2 to this Annex : E2 (Tables : E1 and E2), be not less than the minimum specified in paragraph E2.1.1. above multiplied by the percentage specified in the said table for the direction in question; (Tables : E3, E4, E5 give required intensity values)
- E2.1.2.1.1. In divergence from paragraphs E2.1.2 and E2.1.2.1, for categories 4 and 5 direction indicators, to the rear, a minimum value of 0.6 cd is required throughout the fields specified in Appendix : 1;
- E2.1.2.2. In no direction within the area from which the indicator lamp is visible, exceed the maximum specified in paragraph E2.1.1. above;
- E2.1.2.3. Moreover,
- E2.1.2.3.1. Throughout the fields defined in the diagrams in Annex: E2-Appendix :1, the intensity of the light emitted must be not less than 0.7 cd for devices of category 1b, not less than 0.3 cd for devices of categories 1, 1a, 2a, 3, 4 towards the front and for those of category 2b by day; it shall not be less than 0.07 cd for devices of category 2b by night;
- E2.1.2.3.2. For devices of categories 1 and 2b by night and, to the front, for devices of categories 3 and 4, the intensity of the light emitted outside the zone defined by the measuring points $\pm 10^0$ H and $\pm 10^0$ V (10^0 -field) must not exceed the following values:

Direction Indicator of category	Maximum values in cd outside the 10^0 - field		
	Single lamp	Lamp (single) marked 'D', ⁽¹⁾	Total for the assembly of two lamps ⁽¹⁾
2b by night	100	70	140
1,3 and 4	400	280	560

(1) Devices which may be used as part of an assembly of two lamps

Between the boundaries of the 10^0 - field ($\pm 10^0$ H and $\pm 10^0$ V) and the 5^0 - field ($\pm 5^0$ H and $\pm 5^0$ V), the maximum admissible values of the intensities are linearly increased up to the values as defined in paragraph E2.1.1.

- E2.1.2.3.3. For devices of category 1a and 1b, the intensity of the light emitted outside the zone defined by the measuring points $\pm 15^0$ H and $\pm 15^0$ V (15^0 field) shall not exceed the following values:

Direction indicator Of category	Maximum values in cd outside the 15^0 - field		
	Single lamp	Lamp (single) marled “D”, ⁽¹⁾	Total for assembly of two lamps ⁽¹⁾
1a	250	175	350
1b	400	280	560

(1) Devices which may be used as part of an assembly of two lamps

Between the boundaries of the 15^0 - field ($\pm 15^0$ H and $\pm 15^0$ V) and the 5^0 - field ($\pm 5^0$ H and $\pm 5^0$ V), the maximum values are increased linearly up to the values as defined in paragraph E2.1.1.

- E2.1.2.3.4. The provisions of paragraph E2.App.2.2.2 of Appendix : E2 to this Annex : E2 on local variations of intensity must be observed.

- E2.1.3. In general the intensities shall be measured with the light source(s) continuously alight.

However, depending on the construction of the device, for example, the use of light emitting diodes (LED), or the need to take precautions to avoid overheating, it is allowed to measure the lamps in flashing mode.

This must be achieved by switching with a frequency of $f = 1.5 \pm 0.5$ Hz with the pulse width greater than 0.3 s, measured at 95 per cent peak light intensity.

In the case of replaceable filament lamps, the filament lamps shall be operated at reference luminous flux during on time.

In all other cases the voltage as required in paragraph E2.2.1.1 shall be switched with a rise time and fall time shorter than 0.01 s; no overshoot is allowed. In the case of measurements taken in flashing mode the reported luminous intensity shall be represented by the maximum intensity.

- E2.1.4. In the case of devices of category 2b the time that elapses between electrical supply being switched on and the light output measured on the reference axis to reach 90 % of the value measured in accordance with paragraph E2.1.3. above shall be measured for both the day and the night conditions of use. The time measured for the night condition of use shall not exceed that measured for the day condition of use.

- E2.1.5. Appendix:2 of Annex: E2, referred to in paragraph E2.1.2.1. above, gives particulars of the measurement methods to be used.

E2.2 TEST PROCEDURE

- E2.2.1 All measurements shall be made with an uncoloured or amber-coloured standard filament lamp of the category prescribed for the device, the supply voltage being so regulated as to produce the reference luminous flux prescribed for that category of lamp.

- E2.2.1.1 All measurements on lamps equipped with non-replaceable light sources (filament lamps and other) shall be made at 6.75 V, 13.5 V or 28.0 V respectively.

In the case of light sources supplied by a special power supply, the above test voltages shall be applied to the input terminals of that power supply. The test laboratory may require from the manufacturer the special power supply needed to supply the light sources.

- E2.2.2. However, in the case of an indicator of category 2b for which an additional system ⁽¹⁾ is used to obtain the night-time intensity, the voltage applied to the system for measuring the night-time intensity shall be that which was applied to the filament lamp for

- E2.2.3. The vertical and horizontal outlines of the illuminating surface of a light-signalling device shall be determined and measured in relation to the centre of reference.

(1) The functioning and installation conditions of this additional device will be defined by special provisions measuring the day-time intensity.

ANNEX : E2 - APPENDIX: 1
(See para E2..1.1)

CATEGORIES OF DIRECTION INDICATORS:

MINIMUM ANGLES REQUIRED FOR LIGHT DISTRIBUTION IN SPACE OF THESE CATEGORIES OF DIRECTION INDICATORS ⁽¹⁾

In all cases, the minimum vertical angles of light distribution in space of direction indicator lamps are 15° above and 15° below the horizontal except:

- (i) direction indicator lamps with a mounting height of equal to or less than 750 mm above the ground, for which they are 15° above and 5° below the horizontal;
- (ii) direction indicator lamps of Category 6, for which they are 30° above and 5° below the horizontal.

Minimum Horizontal Angles Of Light Distribution In Space:

Categories 1, 1a and 1b: direction indicators for the front of the vehicle

Category 1 : for use at a distance not less than 40 mm from the headlamp

Category 1a: for use at a distance greater than 20 mm but less than 40 mm from the headlamp

Category 1b: for use at a distance less than 20 mm from the headlamp

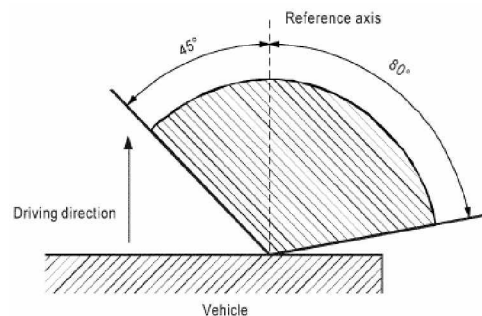

Categories 2a and 2b: direction indicators for the rear of the vehicle

Category 2a: Direction indicators with one level of intensity

Category 2b: Direction indicators with two levels of intensity

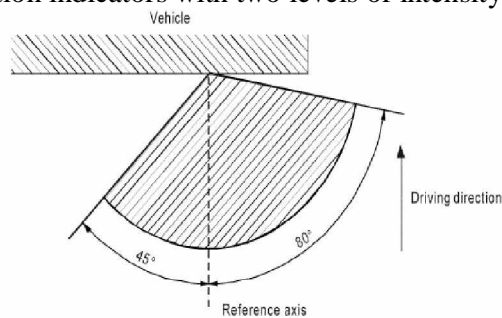

(1) The angles shown in these arrangements are correct for devices to be mounted on the right side of the vehicle. The arrows in these diagrams point towards the front of the vehicle.

Categories 3 and 4: front-side direction indicators

Category 3: Front-side direction indicators for use on a vehicle equipped with this category of direction indicator only

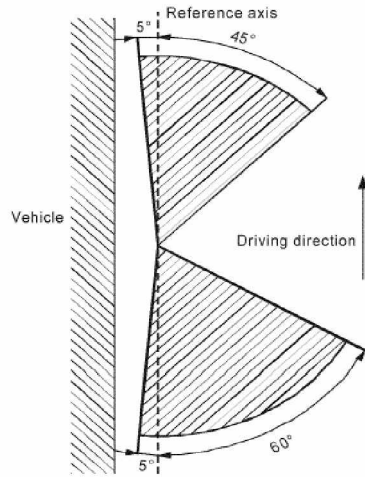

Category 4: Front-side direction indicators for use on a vehicle also equipped with category 2a or 2b direction indicators

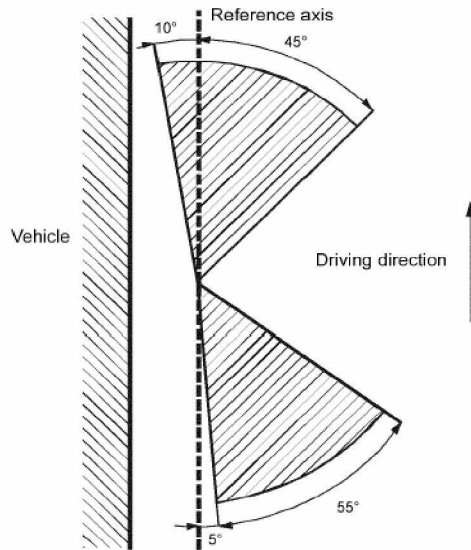

Categories 5 and 6: Supplementary side direction indicators for use on a vehicle also equipped with categories 1, 1a or 1b and 2a or 2b direction indicators

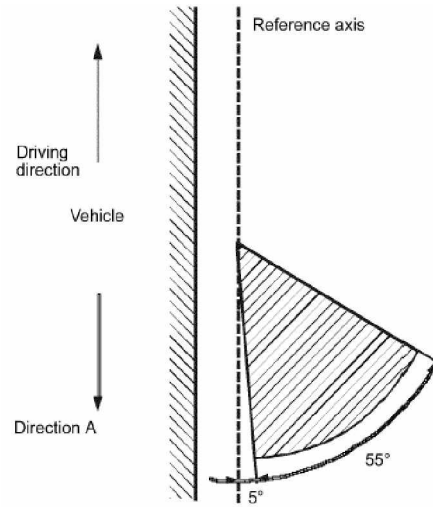

ANNEX: E2 – APPENDIX: 2

(See para E2.1.2.1)

PHOTOMETRIC MEASUREMENTS

E2.APP.2.1. MEASUREMENT METHODS

E2.App.2.1.1. During photometric measurements, stray reflections shall be avoided by appropriate masking.

E2.App.2.1.2. In case the results of measurements should be challenged, measurements shall be carried out in such a way as to meet the following requirements:

E2.App.2.1.2.1. The distance of measurement shall be such that the law of the inverse of the square of the distance is applicable;

E2.App.2.1.2.2. The measuring equipment shall be such that the angular aperture of the receiver viewed from the reference centre of the light is comprised between 10' and 1 degree;

E2.App.2.1.2.3. The intensity requirement for a particular direction of observation shall be deemed to be satisfied if that requirement is met in a direction deviating by not more than one-quarter of a degree from the direction of observation.

E2.App.2.1.3. In the case where the device may be installed on the vehicle in more than one or in a field of different positions the photometric measurements shall be repeated for each position or for the extreme positions of the field of the reference axis specified by the manufacturer.

E2.App.2.2. Table of standard light distribution in space for direction indicator lamps of categories 1, 1a, 1b, 2a, 2b, 3 and 4 (towards the front only).

Table : E1
(See para E2.1.2.1)

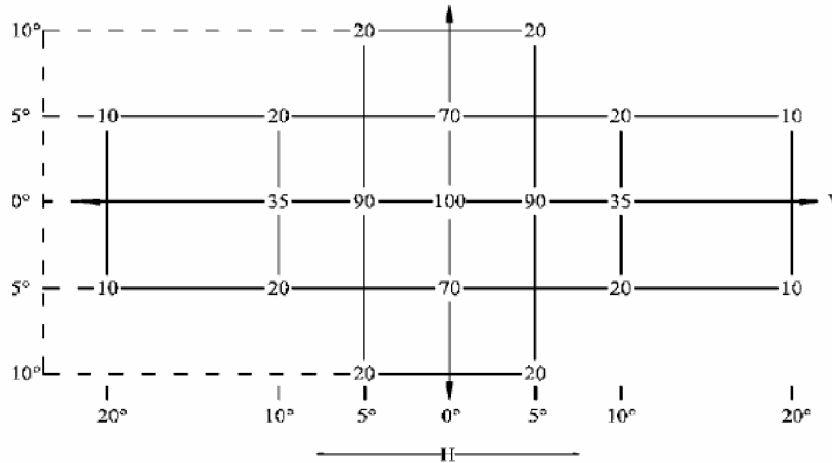

Table : E2
(See para E2.1.2.1)

For direction indicators of category 6

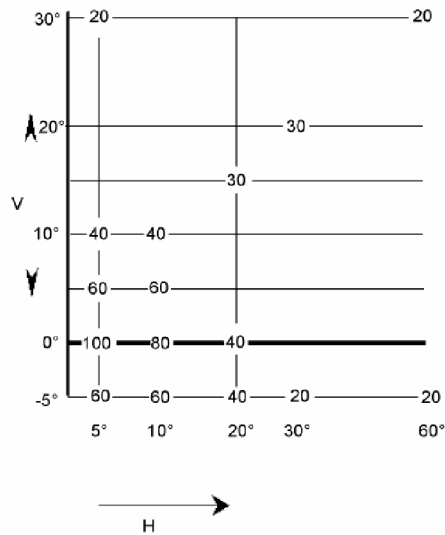

TABLE : E3
 (See para E 2.1.2.1)
INTENSITY VALUES IN CANDELAS FOR DIRECTION INDICATOR

Test Points V ° H °		Front Facing Categories						Rear Facing Categories					
		1		1a		1b		2a		2 b			
		Min.	Max	Min.	Max.	Min.	Max	Min	Max	By Day		By Night	
(1)	(2)	(3)	(4)	(5)	(6)	(7)	(8)	(9)	(10)	(11)	(12)	(13)	(14)
15 U	V	0.3	400	0.3	800	0.7	860	0.3	350	0.3	700	0.07	100
10 U	5 L	35	700	50	800	80	860	10	350	35	700	8	120
10 U	5 R	35	700	50	800	80	860	10	350	35	700	8	120
5 U	20 L	17.5	400	25	250	40	400	5	350	17.5	700	4	100
5 U	10 L	35	700	50	800	80	860	10	350	35	700	8	120
5 U	V	122.5	700	175	800	280	860	35	350	122.5	700	28	120
5 U	10 R	35	700	50	800	80	860	10	350	35	700	8	120
5 U	20R	17.5	400	25	250	40	400	5	350	17.5	700	4	100
H	80 L	0.3	400	0.3	250	0.7	400	0.3	350	0.3	700	0.07	100
H	45 L	0.3	400	0.3	250	0.7	400	0.3	350	0.3	700	0.07	100
H	10 L	61.25	700	87.5	800	140	860	17.5	350	61.25	700	14	120
H	5 L	157.5	700	225	800	360	860	45	350	157.5	700	36	120
H	V	175	700	250	800	400	860	50	350	175	700	40	120
H	5 R	157.5	700	225	800	360	860	45	350	157.5	700	36	120
H	10 R	61.25	700	87.5	800	140	860	17.5	350	61.25	700	14	120
H	45 R	0.3	400	0.3	250	0.7	400	0.3	350	0.3	700	0.07	100
H	80 R	0.3	400	0.3	250	0.7	400	0.3	350	0.3	700	0.07	100
5 D	20 L	17.5	400	25	250	40	400	5	350	17.5	700	4	100
5 D	10 L	35	700	50	800	80	860	10	350	35	700	8	120
5 D	V	122.5	700	175	800	280	860	35	350	122.5	700	28	120
5 D	10 R	35	700	50	800	80	860	10	350	35	700	8	120
5 D	20 R	17.5	400	25	250	40	400	5	350	17.5	700	4	100
10 D	5 L	35	700	50	800	80	860	10	350	35	700	8	120
10 D	5 R	35	700	50	800	80	860	10	350	35	700	8	120
15 U	V	0.3	400	0.3	800	0.7	860	0.3	350	0.3	700	0.07	100

Table: E4
(See para E2.1.2.1)
INTENSITY VALUES IN CANDELAS FOR
DIRECTOR INDICATOR OF CATEGORY 3,4

Test points		Direction Indicator Category							
γ^0	H^0	Category 3				Category 4			
		Toward Front		Towards Rear		Towards Front		Towards Rear	
		Min.	Max. ⁽²⁾	Min	Max. ⁽²⁾	Min.	Max. ⁽²⁾	Min.	Max. ⁽²⁾
15 U	V	0.3	-	0.3	-	0.3	-	0.6	-
10 U	5 L	35	-	10	-	35	-	0.6	-
10 U	5 R	35	-	10	-	35	-	0.6	-
5 U	20 L	17.5	-	5	-	17.5	-	0.6	-
5 U	10 L	35	-	10	-	35	-	0.6	-
5 U	V	122.5	-	35	-	122.5	-	0.6	-
5 U	10 R	35	-	10	-	35	-	0.6	-
5 U	20 R	17.5	-	5	-	17.5	-	0.6	-
H	60 L ⁽¹⁾	0.3	-	0.3	-	NA	-	0.6	-
H	45 L	0.3	-	NA	-	0.3	-	NA	-
H	10 L	61.3	-	17.5	-	61.3	-	0.6	-
H	5 L	157.5	-	45	-	157.5	-	0.6	-
H	V	175	-	50	-	175	-	0.6	-
H	5 R	157.5	-	45	-	157.5	-	0.6	-
H	10 R	61.3	-	17.5	-	61.3	-	0.6	-
H	45 R	0.3	-	NA	-	0.3	-	NA	-
H	60 R ⁽¹⁾	0.3	-	0.3	-	NA	-	0.6	-
5 D	20 L	17.5	-	5	-	17.5	-	0.6	-
5 D	10 L	35	-	10	-	35	-	0.6	-
5 D	V	122.5	-	35	-	122.5	-	0.6	-
5 D	10 R	35	-	10	-	35	-	0.6	-
5 D	20 R	17.5	-	5	-	17.5	-	0.6	-
10 D	5 L	35	-	10	-	35	-	0.6	-
10 D	5 R	35	-	10	-	35	-	0.6	-
15 D	V	0.3	-	0.3	-	0.3	-	0.6	-

- (1) The point (H, 60L), (H,60R) is same as (H, 55L), (H, 55R) in case of Category 4 direction indicator.
- (2) For maximum values refer paragraph E2.1, E2.1.1. and in case of single lamp.

Table : E5
(See para E2.1.2.1)

**INTENSITY VALUES IN CANDELAS FOR
DIRECTION INDICATOR OF CATEGORY 5 AND 6**

Test Points		Direction Indicatory Category			
V ⁰	4 ⁰	Category 5		Category 6	
	(outside of the vehicle)	Min.	Max. ⁽¹⁾	Min.	Max. ⁽¹⁾
30 U	60 L/R	0.6	200	10	200
30 U	5 L/R	0.6	200	10	200
20 U	30 L/R	0.6	200	15	200
15 U	20 L/R	0.6	200	15	200
10 U	10 L/R	0.6	200	20	200
10 U	5 L/R	0.6	200	20	200
5 U	10 L/R	0.6	200	30	200
5 U	5 L/R	0.6	200	30	200
H	60 L/R	0.6	200	NA	NA
H	20 L/R	0.6	200	20	200
H	10 L/R	0.6	200	40	200
H	5 L/R	0.6	200	50	200
H	V	NA	NA	NA	NA
5 D	60 L/R	0.6	200	10	200
5 D	30 L/R	0.6	200	10	200
5 D	20 L/R	0.6	200	20	200
5 D	10 L/R	0.6	200	30	200
5 D	5 L/R	0.6	200	30	200

(1) Single lamp

E2.App.2.2.1. The direction H = 0⁰ and V = 0⁰ corresponds to the reference axis. (On the vehicle, it is horizontal, parallel to the median longitudinal plane of the vehicle and oriented in the required direction of visibility.) It passes through the centre of reference. The values shown in the tables give, for the various directions of measurement, the minimum intensities as a percentage of the minimum intensities required in the table in paragraph E 2.1.1.

E2.App.2.2.1.1. in the direction H = 0⁰ and V = 0⁰ for categories 1, 1a, 1b, 2a, 2b, 3 and in the case of category 4 to the front only;

E2.App.2.2.1.2. in the direction H = 5⁰ and V = 0⁰ for category 6.

E2.App.2.2.1.3. However, in the case where a device is intended to be installed at a mounting height of equal to or less than 750 mm above the ground, the photometric intensity is verified only up to an angle of 5° downwards.

E2.App.2.2.2. Within the field of light distribution of paragraph E2.App2.2. schematically shown as a grid, the light pattern should be substantially uniform, i.e. in so far as the light intensity in each direction of a part of the field formed by the grid lines shall meet at least the lowest minimum value being shown on the grid lines surrounding the questioned direction as a percentage.

E2.App.2.3. **Photometric Measurement of Lamps**
The photometric performance shall be checked:

E2.App.2.3.1. **For non-replaceable light sources (filament lamps and other):**
with the light sources present in the lamp, in accordance with paragraph E2.2.1.1. of Annex : E2.

E2.App.2.3.2. For replaceable filament lamps:

When equipped with filament lamps at 6.75 V, 13.5 V or 28.0 V, the luminous intensity values produced shall be corrected. The correction factor is the ratio between the reference luminous flux and the mean value of the luminous flux found at the voltage applied (6.75 V, 13.5 V or 28.0 V). The actual luminous fluxes of each filament lamp used shall not deviate more than $\pm 5\%$ from the mean value. Alternatively a standard filament lamp may be used in turn, in each of the individual positions, operated at its reference flux, the individual measurements in each position being added together.

E2.App.2.3.3. For any direction indicator lamp except those equipped with filament lamp(s), the luminous intensities measured after one minute and after 30 minutes of operation in flashing mode ($f = 1.5$ Hz, duty factor 50 %), shall comply with the minimum and maximum requirements. The luminous intensity distribution after one minute of operation can be calculated by applying at each test point the ratio of luminous intensity measured in HV after one minute and after 30 minutes of operation as above described.

ANNEX: E3

(See para 5.5 and E1.1.1)

COLOUR OF LIGHT EMITTED**E3.1 COLOUR OF LIGHT EMITTED**

The colour of the light emitted inside the field of the light distribution grid defined in paragraph E2.App.2.2 of Appendix E2 of Annex : E2 of this standard shall be within the limits of the coordinates prescribed below in para E3.2.

Outside this field, no sharp variation of colour shall be observed.

E3.2 COLOUR OF AMBER LIGHTS:**TRICHROMATIC CO-ORDINATES**

Limit towards yellow or Limit towards green	$y \leq 0.429$ or $y \leq x - 0.120$
Limit towards red	$y \geq 0.398$ or $y \geq 0.390$
Limit towards white	$z \leq 0.007$ or $y \leq 0.790 - 0.670 x$

For checking these colorimetric characteristics, a source of light at a colour temperature of 2,856 K corresponding to illuminant A of the International Commission on Illumination (CIE) shall be used .

However, for lamps equipped with non-replaceable light sources (filament lamps and other), the colorimetric characteristics should be verified with the light sources present in the lamp, in accordance with paragraph E 2.2.1.1. of Annex : E2.

ANNEX: E 4

(See para 8.0)

**MINIMUM REQUIREMENTS FOR CONFORMITY OF
PRODUCTION CONTROL PROCEDURES****E4.1. GENERAL**

Refer paragraph D4.1. of Annex : D4 with replacing “director indicator” for “lamp” wherever it appears.

**E4.2. MINIMUM REQUIREMENTS FOR VERIFICATION OF
CONFORMITY BY THE MANUFACTURER**

Refer para A 6.2 of Annex : A 6 with replacing word “direction indicator” for “headlamp” wherever it appears.

E4.2.1. Nature of Tests

Tests of conformity in this standard shall cover the photometric and colorimetric characteristics.

E4.2.2. Methods used in tests

Refer paragraph A 6.2.2 of Annex : A 6 with replacing word “direction indicator” for “headlamp” wherever it appears.

E4.2.3. Nature of Sampling

Refer paragraph A 6.2.3. of Annex : A 6 with replacement of word “direction indicator” for “head lamp” wherever it appears.

E4.2.4. Measured and Recorded Photometric Characteristics

The sampled direction indicator shall be subjected to photometric measurements for the minimum values at the points listed in Annex: E2-Appendix – 2 and the chromaticity coordinates in para E3.2 of Annex: E3 , provided for in relevant Annexes.

E4.2.5. Criteria Governing Acceptability

The manufacturer is responsible for carrying out a statistical study of the test results and for defining, in agreement with the test agency, criteria governing acceptability of his products in order to meet the specification laid down for verification of conformity of products in paragraph 8.1 of this standard.

The criteria governing acceptability shall be such that, with a confidence level of 95%, the minimum probability of passing a spot check in accordance with Annex : E 5 (first sampling) would be 0.95.

ANNEX: E 5
(See para 8.0 and E 4.2.5 of Annex: E4)

**MINIMUM REQUIREMENTS FOR
SAMPLING BY AN INSPECTOR**

E5.1. GENERAL

- E5.1.1 Refer paragraph D5.1. 1 of Annex : D5 with replacement of word “direction indicator” for “lamp” wherever it appear.
- E5.1.2 Refer paragraph D5.1. 2 of Annex : D5 with replacement of word “direction indicator” for “lamp” wherever it appear.
- E5.1.2.1 Refer paragraph D5.1. 2.1 of Annex : D5 with replacement of word “direction indicator” for “lamp” wherever it appear.
- E5.1.2.2 If, in the case of a direction indicator equipped with a replaceable light source and if results of the test described above do not meet the requirements, test on direction indicator shall be repeated using another standard filament lamp.
- E5.1.2.3 Direction indicators with apparent defects are disregarded
- E5.1.3 Refer paragraph D5.1.3 of Annex : D5 with replacement of word “direction indicator” for “lamp” wherever it appear.

E5.2. FIRST SAMPLING

E5.2.1 The Conformity is Not Contested

- E5.2.1.1 Refer paragraph A7.2.1.1 of Annex : A7 with replacement of word “direction indicator” for “headlamp” wherever it appears.
- E5.2.1.1.1 Refer paragraph A7..2.1.1.1. of Annex : A7 with replacing word “direction indicator” for “headlamp” wherever it appears.

E5.2.1.1.2 Sample B

B1:	Both direction indicator		0 %
-----	--------------------------	--	-----

E5.2.1.2. or if the conditions of paragraph E5.1.2.2. for Sample A are fulfilled.

E5.2.2. The Conformity is Contested

- E5.2.2..1 Refer paragraph A7.2.2.1 of Annex : A7 with replacement of word “direction indicator” for “headlamp” wherever it appears.
- E5.2.2..1.1 Refer paragraph A7.2.2.1.1. of Annex : A7 with replacing word “direction indicator” for “headlamp” wherever it appears.

E5.2.2.1.2 **Sample B**

Refer paragraph A7.2.2.1.2. of Annex : A7 with replacing word “direction indicator” for “headlamp” wherever it appears.

E5.2.2.2 or if the conditions of paragraph E5.1.2.2. for sample A are not fulfilled.

E5.2.3. **Approval Withdrawn**

Refer paragraph A7.2.3. of Annex : A7 with replacement of word “direction indicator” for “headlamp” wherever it appears.

E5.2.3.1 **Sample A**

Refer paragraph A7.2.3.1. of Annex : A7 with replacing word “direction indicator” for “headlamp” wherever it appears.

E5.2.3.2. **Sample B**

Refer paragraph A7.2.3.2. of Annex : A7 with replacing word “direction indicator ” for “headlamp” wherever it appears.

E5.2.3.3. or if the conditions of paragraph E5.1.2.2. for samples A and B are not fulfilled.

E5.3. Repeated Sampling

Refer paragraph A7.3 of Annex : A7 with replacement of word “direction indicator” for “headlamp” wherever it appears.

E5.3.1. **The Conformity is Not Contested**

E5.3.1.1. Refer paragraph A7.3.1.1 of Annex : A7 with replacing word “direction indicator” for “headlamp” wherever it appears.

E5.3.1.1.1. **Sample C**

Refer paragraph A7.3.1.1.1. of Annex : A7 with replacing word “direction indicator” for “headlamp” wherever it appears.

E5.3.1.1.2. **Sample D**

D1:	in the case of C2		
	Both direction indicators		0%

- E5.3.1.2. or if the conditions of paragraph E5.1.2.2. for sample C are fulfilled.
- E5.3.2. **The Conformity is Contested**
- E5.3.2.1. Refer paragraph A7.3.2.1. of Annex : A7 with replacing word “direction indicator” for “headlamp” wherever it appears.
- E5.3.2.1.1. **Sample D**
Refer paragraph A7.3.2.1.1. of Annex : A7 with replacing word “direction indicator ” for “headlamp” wherever it appears.
- E5.3.2.1.2. or if the conditions of paragraph E5.1.2.2 for sample C are not fulfilled.
- E5.3.3. **Approval Withdrawn**
Refer paragraph A7.3.3. of Annex : A7 with replacing word “direction indicator ” for “headlamp” wherever it appears.
- E5.3.3.1. **Sample C**
Refer paragraph A7.3.3.1. of Annex : A7 with replacing word “direction indicator ” for “headlamp” wherever it appears.
- E5.3.3.2. **Sample D**
Refer paragraph A7.3.3.2. of Annex : A7with replacing word “direction indicator ” for “headlamp” wherever it appears.
- E5.3.3.3. or if the conditions of paragraph E5.1.2.2. for samples C and D are not fulfilled.

ANNEX: F1

(See para 5.6)

REQUIREMENTS FOR REVERSING LAMPS

F1.1 GENERAL SPECIFICATIONS

- F1.1.1. Each sample shall conform to the specifications set forth in the Annexes: F1,F2, F3 and Annex : L.
- F1.1.2. Reversing lamps shall be so designed and constructed that in normal use, despite the vibration to which they may then be subjected, they continue to function satisfactorily and retain the characteristics prescribed by this standard.

ANNEX: F2
(See para. F1.1.1)

**PHOTOMETRIC TEST PROCEDURE AND INTENSITY
REQUIREMENTS FOR REVERSING LAMPS**

F2.1 INTENSITY OF LIGHT EMITTED

F2.1.1. The intensity of the light emitted by each of the two samples shall be not less than the minima and not greater than the maxima specified below and shall be measured in relation to the axis of reference in the directions shown below (expressed in degrees of angle with the axis of reference).

F2.1.2. The intensity along the axis of reference shall be not less than 80 candelas.

F2.1.3. The intensity of the light emitted in all directions in which the light can be observed shall not exceed:

300 candelas in directions in or above the horizontal plane;

and, in directions below the horizontal plane:

300 candelas between h-h and 5° D and

600 candelas below 5° D.

F2.1.4. In every other direction of measurement shown in Annex F2 – Appendix: 1 to this Annex, the luminous intensity shall be not less than the minima specified in that Appendix : F1.

However, in the case where the reversing lamp is intended to be installed on a vehicle exclusively in a pair of devices, the photometric intensity may be verified only up to an angle of 30° inwards where a photometric value of at least 25 cd shall be satisfied.

This condition shall be clearly explained in the application for approval and relating documents.

Moreover, in the case where the type approval will be granted applying the condition above, the device shall only be installed on vehicle in a pair.

F2.1.5. In the case of a single lamp containing more than one light source, the lamp shall comply with the minimum intensity required when any one light source has failed and when all light sources are illuminated the maximum intensities shall not be exceeded.

F2.2 TEST PROCEDURE

F2.2.1. All measurements shall be carried out with uncolored standard filament lamps of the types prescribed for the device, adjusted to produce the normal luminous flux prescribed for those types of filament lamps.

F2.2.1.1 All measurements on lamps equipped with non-replaceable light sources (filament lamps and other) shall be made at 6.75 V, 13.5 V or 28.0 V respectively.

In the case of light sources supplied by a special power supply, the above test voltages shall be applied to the input terminals of that power supply. The test laboratory may require from the manufacturer the special power supply needed to supply the light sources.

ANNEX : F2 – APPENDIX :1
(See para F2.1.4)

PHOTOMETRIC MEASUREMENTS

F2.App.1.1 MEASUREMENT METHODS

F2.App.1.1.1 When photometric measurements are taken, stray reflections shall be avoided by appropriate masking.

F2.App.1.1.2 In the event that the results of measurements are challenged, measurements shall be taken in such a way as to meet the following requirements:

F2.App.1.1.2.1. the distance of measurement shall be such that the law of the inverse of the square of the distance is applicable;

F2.App.1.1.2.2 the measuring equipment shall be such that the angle subtended by the receiver from the reference center of the light is between 10' and 1°

F2.App.1.1.2.3 the intensity requirement for a particular direction of observation shall be satisfied if the required intensity is obtained in a direction deviating by not more than one quarter of a degree from the direction of observation.

F2.App.1.1.3 In the case where the device may be installed on the vehicle in more than one or in a field of different positions the photometric measurements shall be repeated for each position or for the extreme positions in the field of reference axis specified by the manufacturer.

F2.App.1.2. MEASURING POINTS EXPRESSED IN DEGREES OF ANGLE WITH THE AXIS OF REFERENCE AND VALUES OF THE MINIMUM INTENSITIES OF THE LIGHT EMMITED.

F2.App.1.2.1. The directions $H = 0^0$ and $V = 0^0$ degrees correspond to the axis of reference. On the vehicle they are horizontal, parallel to the median longitudinal plane of the vehicle and oriented in the required direction of visibility. They pass through the centre of reference. The values shown in the Table: F1 give, for the various directions of measurement, the minimum intensities in cd.

F2.App.1.2.2. If visual examination of a lamp appears to reveal substantial local variations of intensity, a check shall be made to ensure that no intensity measured between two of the directions of measurement referred to above is below 50 per cent of the lower minimum intensity of the two prescribed for these directions of measurement.

F2.App.1.3. PHOTOMETRIC MEASUREMENT OF LAMP EQUIPPED WITH SEVERAL LIGHT SOURCES

The photometric performance shall be checked:

F2.App.1.3.1. For non-replaceable light sources (filament lamps and other):
with the light sources present in the lamp, in accordance with paragraph F2.2.1.1. of Annex : F2

F2.App.1.3.2. For replaceable filament lamps:
when equipped with filament lamps at 6.75 V, 13.5 V or 28.0 V, the luminous intensity values produced shall be corrected. The correction factor is the ratio between the reference luminous flux and the mean value of the luminous flux found at the voltage applied (6.75 V, 13.5 V or 28.0 V). The actual luminous fluxes of each filament lamp used shall not deviate more than $\pm 5\%$ from the mean value. Alternatively a standard filament lamp may be used in turn, in each of the individual positions, operated at its reference flux, the individual measurements in each position being added together.

Table : F1
(See para F2.App.1.2.1)

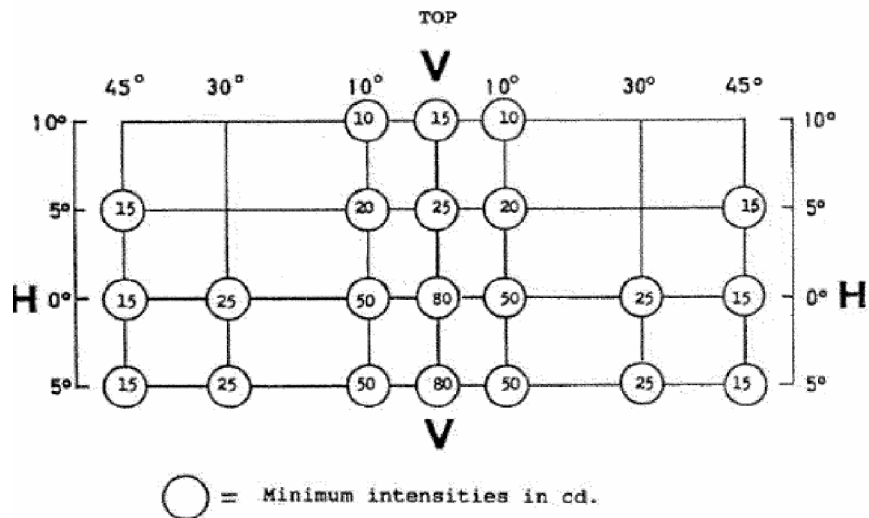

ANNEX: F3
(See para F1.1.1)

COLOUR OF LIGHT EMITTED

F3.1. COLOUR OF LIGHT EMITTED

The colour of the light emitted inside the field of the light distribution grid defined at paragraph F2.App. 1.2 of Appendix : F1 of Annex : F2 shall be white and, in case of doubt, may be checked on the basis of the definition of the colour of white light given below. Outside this field no sharp variation of colour shall be observed.

F3.2 COLOUR OF WHITE LIGHT

(Trichromatic coordinates)	
Limit towards blue	: $x \geq 0.310$
Limit towards yellow	: $x \leq 0.500$
Limit towards green	: $y \leq 0.150 + 0.640x$
Limit towards green	: $y \leq 0.440$
Limit towards purple	: $y \geq 0.050 + 0.750x$
Limit towards red	: $y \geq 0.382$

For checking these colorimetric characteristics, a source of light at a colour temperature of 2,854⁰ K corresponding to illuminant A of the International Commission on Illumination (ICI) shall be used.

However, for lamps equipped with non-replaceable light sources (filament lamps and other), the colorimetric characteristics shall be verified with the light sources present in the lamp, in accordance with paragraph F2.2.1.1 of Annex : F2

ANNEX: F 4
(See para 8.0)

**MINIMUM REQUIREMENTS FOR CONFORMITY OF
PRODUCTION CONTROL PROCEDURES**

F4.1. GENERAL

Refer paragraph D4.1. of Annex : D4 with replacing “reversing lamp” for “lamp” wherever it appears.

**F4.2. MINIMUM REQUIREMENTS FOR VERIFICATION OF
CONFORMITY BY THE MANUFACTURER**

Refer para A 6.2 of Annex : A 6 with replacing word “reversing lamp” for “headlamp” wherever it appears.

F4.2.1. Nature of Tests

Tests of conformity in this standard shall cover the photometric and colorimetric characteristics.

F4.2.2. Methods used in tests

Refer paragraph A6.2.2 of Annex : A6 with replacing word “reversing lamp” for “headlamp” wherever it appears.

F4.2.3. Nature of Sampling

Refer paragraph A6.2.3. of Annex : A 6 with replacement of word “reversing lamp” for “head lamp” wherever it appears.

F4.2.4. Measured and Recorded Photometric Characteristics

The sampled reversing lamp shall be subjected to photometric measurements for the minimum values at the points listed in Annex: F2-Appendix -1 and the chromaticity coordinates in para F3.2 of Annex: F3 , provided for in respective Annexes.

F4.2.5. Criteria Governing Acceptability

The manufacturer is responsible for carrying out a statistical study of the test results and for defining, in agreement with the test agency, criteria governing acceptability of his products in order to meet the specification laid down for verification of conformity of products in paragraph 8.1 of this standard.

The criteria governing acceptability shall be such that, with a confidence level of 95%, the minimum probability of passing a spot check in accordance with Annex : F5 (first sampling) would be 0.95.

Annex: F 5

(See para 8.0 and para F4.2.5 of Annex :F4)

MINIMUM REQUIREMENTS FOR SAMPLING BY AN INSPECTOR

F5.1. GENERAL

- F5.1.1 Refer paragraph D5.1. 1 of Annex : D5 with replacement of word “reversing lamp” for “lamp” wherever it appear.
- F5.1.2 Refer paragraph D5.1. 2 of Annex : D5 with replacement of word “reversing lamp” for “lamp” wherever it appear.
- F5.1.2.1 Refer paragraph D5.1. 2.1 of Annex : D5 with replacement of word “reversing lamp” for “lamp” wherever it appear.
- F5.1.2.2 If, in the case of a “reversing lamp” equipped with a replaceable light source and if results of the test described above do not meet the requirements, test on “reversing lamp” shall be repeated using another standard filament lamp.
- F5.1.2.3 “Reversing lamp” with apparent defects are disregarded
- F5.1.3 Refer paragraph D5.1.3 of Annex : D5 with replacement of word “reversing lamp” for “lamp” wherever it appear.

F5.2. FIRST SAMPLING

F5.2.1 The Conformity is Not Contested

- F5.2.1.1 Refer paragraph A7.2 of Annex : A7 with replacement of word “reversing lamp” for “headlamp” wherever it appears.
- F5.2.1.1.1 Refer paragraph A7.2.1.1.1. of Annex : A7 with replacing word “reversing lamp” for “headlamp” wherever it appears.

F5.2.1.1.2 Sample B

B1:	Both reversing lamp		0 %
-----	---------------------	--	-----

F5.2.1.2. or if the conditions of paragraph F5.1.2.2. for Sample A are fulfilled.

F5.2.2. The Conformity is Contested

- F5.2.2.1 Refer paragraph A7.2.2.1 of Annex : A7 with replacement of word “reversing lamp” for “headlamp” wherever it appears.

F5.2.2.1.1 Refer paragraph A7.2.2.1.1. of Annex : A7 with replacing word “reversing lamp” for “headlamp” wherever it appears.

F5.2.2.1.2 **Sample B**

Refer paragraph A7.2.2.1.2. of Annex : A7 with replacing word “reversing lamp” for “headlamp” wherever it appears.

F5.2.2.2 or if the conditions of paragraph F5.1.2.2. for sample A are not fulfilled.

F5.2.3. **Approval Withdrawn**

Refer paragraph A7.2.3. of Annex : A7 with replacement of word “reversing lamp” for “headlamp” wherever it appears.

F5.2.3.1 **Sample A**

Refer paragraph A7.2.3.1. of Annex : A7 with replacing word “reversing lamp” for “headlamp” wherever it appears.

F5.2.3.2. **Sample B**

Refer paragraph A7.2.3.2. of Annex : A7 with replacing word “reversing lamp” for “headlamp” wherever it appears.

F5.2.3.3. or if the conditions of paragraph F5.1.2.2. for samples A and B are not fulfilled.

F5.3. REPEATED SAMPLING

Refer paragraph A7.3 of Annex : A7 with replacement of word “reversing lamp” for “headlamp” wherever it appears.

F5.3.1. **The Conformity is Not Contested**

E5.3.1.1. Refer paragraph A7.3.1.1 of Annex:A7 with replacing word “reversing lamp” for “headlamp” wherever it appears.

F5.3.1.1.1. **Sample C**

Refer paragraph A7.3.1.1.1. of Annex:A7 with replacing word “reversing lamp” for “headlamp” wherever it appears.

F5.3.1.1.2. **Sample D**

D1:	in the case of C2		
	Both “reversing lamp”		0%

- F5.3.1.2. **or if the conditions of paragraph F5.1.2.2. for sample C are fulfilled.**
- F5.3.2. **The Conformity is Contested**
- F5.3.2.1. Refer paragraph A7.3.2.1. of Annex : A7 with replacing word “reversing lamp” for “headlamp” wherever it appears.
- F5.3.2.1.1. **Sample D**
Refer paragraph A7.3.2.1.1. of Annex : A7 with replacing word “reversing lamp” for “headlamp” wherever it appears.
- F5.3.2.1.2. or if the conditions of paragraph F5.1.2.2 for sample C are not fulfilled.
- F5.3.3. **Approval Withdrawn**
Refer paragraph A7.3.3. of Annex : A7 with replacing word “reversing lamp” for “headlamp” wherever it appears.
- F5.3.3.1. **Sample C**
Refer paragraph A7.3.3.1. of Annex : A7 with replacing word “reversing lamp” for “headlamp” wherever it appears.
- F5.3.3.2. **Sample D**
Refer paragraph A7.3.3.2. of Annex : A7with replacing word “reversing lamp” for “headlamp” wherever it appears.
- F5.3.3.3. or if the conditions of paragraph F5.1.2.2. for samples C and D are not fulfilled.

ANNEX: G1
(See para 5.7)

REQUIREMENTS FOR PARKING LAMPS

G1.1 GENERAL SPECIFICATIONS

G1.1.1 Each sample shall conform to the specifications of Annexes : G1,G2,G3 and Annex L

G1.1.2. Parking lamps shall be so designed and constructed that in normal use, despite the vibrations to which they may be subjected, their satisfactory operation continues to be ensured and they retain the characteristics prescribed by this standard.

ANNEX: G2
(See para G1.1.1)

G2.1. PHOTOMETRIC CHARACTERISTICS

G2.1.1. In the reference axis, the light emitted by each of the two samples shall be of not less than the minimum intensity and of not more than the maximum intensity specified below:

G2.1.1.1.

Intensity of forward facing parking lamps		
Minimum (cd)	:	2
Maximum (cd)	:	60

G2.1.1.2

Intensity of rearward facing parking lamps		
Minimum (cd)	:	2
Maximum (cd)	:	30

G2.1.1.3 In the case of a single lamp containing more than one light source, the lamp shall comply with the minimum intensity required when any one light source has failed and when all light sources are illuminated the maximum intensities shall not be exceeded.

All light sources, which are connected in series, are considered to be one light source.

G2.1.2. Outside the reference axis and within the angular fields defined in the diagrams in Annex:G2 – Appendix:1 to this Annex, the intensity of the light emitted by each of the two samples shall:

G2.1.2.1. In each direction corresponding to the points in the luminous intensity distribution table reproduced in Annex: G2 – Appendix: 2 (Table : G1)to this Annex be not less than the value shown in the said table for the direction in question, expressed as a percentage of the minimum specified in paragraph G2.1.1.; (Table: G2 gives required intensity values)

G2.1.2.2. in any direction within the space from which the light in question is visible, not exceed the maximum specified in paragraph G2.1.1.

G2.1.2.3. however, a luminous intensity of 60 cd shall be permitted for parking lamps directed to the rear incorporated with stop lamps (see paragraph G2.1.2.) below a plane forming an angle of 5° with and downward from the horizontal plane;

G2.1.2.4 Moreover,
G2.1.2.4.1. throughout the fields defined in Annex:G2–Appendix:1 the intensity of the light emitted shall be not less than 0.05 cd,

G2.1.2.4.2. the requirements of para G2.App.2.2.2 of Annex :G2–Appendix : 2 on local variations of intensity shall be observed.

G2.1.3. Annex :G2 – Appendix :2 of this standard to which reference is made in paragraph G2.1.2.1. gives particulars of the methods of measurement to be used.

G2.2. TEST PROCEDURE

All measurements shall be carried out with uncoloured standard filament lamps of the types prescribed for the device, adjusted to produce the normal luminous flux prescribed for those types of lamps.

G2.2.1. All measurements on lamps equipped with non-replaceable light sources (filament lamps and other) shall be made at 6.75 V, 13.5 V or 28.0 V respectively.

In the case of light sources supplied by a special power supply, the above test voltages shall be applied to the input terminals of that power supply. The test laboratory may require from the manufacturer the special power supply needed to supply the light sources.

ANNEX: G2 – APPENDIX: 1
 (See Para G2.1.2 of Annex G2)

**MINIMUM ANGLES REQUIRED FOR THE
 LIGHT DISTRIBUTION IN SPACE ⁽¹⁾**

In all cases, the minimum vertical angles of light distribution in space are 15° above and 15° below the horizontal except for lamps with a mounting height of equal to or less than 750 mm above the ground, for which they are 15° above and 5° below the horizontal.

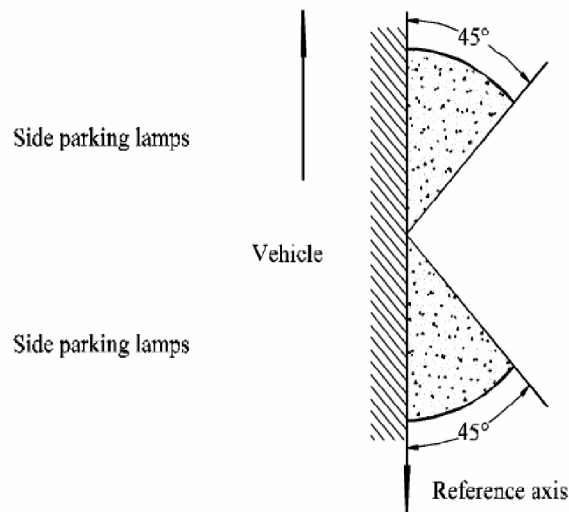
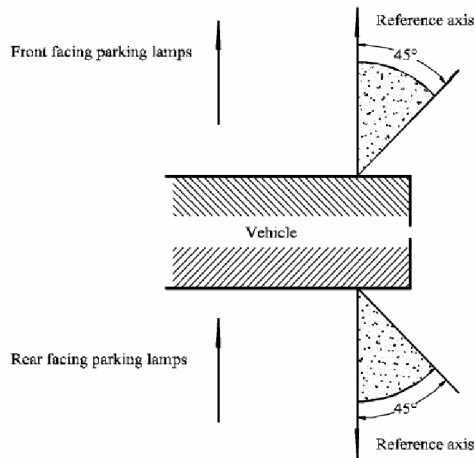

(1) The angles shown in these diagrams are correct for devices to be mounted on the right side of the vehicle. The arrows point to the front of the vehicles.

ANNEX: G2 – APPENDIX: 2
 (See para G2.1.2.1 of Annex:G2)

PHOTOMETRIC MEASUREMENTS

G2.App.2.1. MEASUREMENT METHODS

G2.App.2.1.1. During photometric measurements, stray reflections shall be prevented by appropriate masking.

G2.App.2.1.2. Should the results of measurements be challenged, measurements shall be carried out in such a way as to meet the following requirements:

G2.App.2.1.2.1. the distance of measurements shall be such that the law of the inverse of the square of the distance is applicable;

G2.App.2.1.2.2. the measuring equipment shall be such that the angular aperture of the receiver viewed from the reference centre of the light is between 10' and 1°;

G2.App.2.1.2.3. the intensity requirement for a particular direction of observation shall be deemed to be satisfied if that requirement is met in a direction deviating by not more than 15' from the direction of observation.

G2.App.2.2. STANDARD INTENSITY DISTRIBUTION TABLE

Table : G1
 (See para G2.1.2.1)

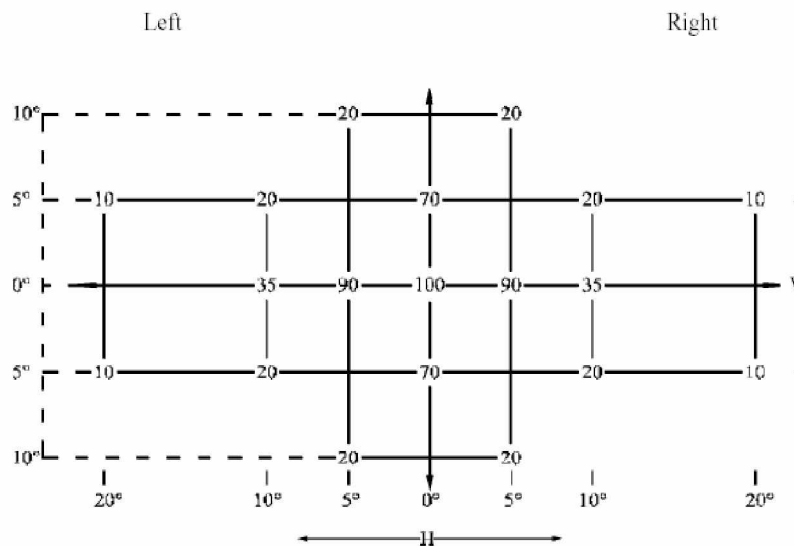

TABLE : G 2
(See para G2.1.2.1)
LUMINOUS INTENSITY VALUES IN CANDELAS
FOR PARKING LAMP

Test Points V° H°		Front facing		Rear facing	
		Min.	Max.	Min.	Max.
(1)	(2)	(3)	(4)	(5)	(6)
15 U	V	0.05	60	0.05	30
10 U	5 L	0.4	60	0.4	30
10 U	5 R	0.4	60	0.4	30
5 U	20 L	0.2	60	0.2	30
5 U	10 L	0.4	60	0.4	30
5 U	V	1.4	60	1.4	30
5 U	10 R	0.4	60	0.4	30
5 U	20 R	0.2	60	0.2	30
H	80 L	-	60	-	30
H	45 L	0.05	60	0.05	30
H	10 L	0.7	60	0.7	30
H	5 L	1.8	60	1.8	30
H	V	2.0	60	2.0	30
H	5 R	1.8	60	1.8	30
H	10 R	0.7	60	0.7	30
H	45 R	0.05	60	0.05	30
H	80 R	-	60	-	30
5 D	20 L	0.2	60	0.2	30
5 D	10 L	0.4	60	0.4	30
5 D	V	1.4	60	1.4	30
5 D	10 R	0.4	60	0.4	30
5 D	20 R	0.2	60	0.2	30
10 D	5 L	0.4	60	0.4	30
10 D	5 R	0.4	60	0.4	30
15 D	V	0.05	60	0.05	30

- G2.App.2.2.1. The direction $H = 0$ degrees and $V = 0$ degrees corresponds to the reference axis. (On the vehicle it is horizontal, parallel to the median longitudinal plane of the vehicle and oriented in the required direction of visibility). It passes through the centre of reference. The values shown in the table give, for the various directions of measurements, the minimum intensities as a percentage of the minimum required in the axis for each lamp (in the direction $H = 0$ degrees and $V = 0$ degrees).
- G2.App.2.2.2. Within the field of light distribution of paragraph G2.App.2.2., of Appendix :2 to Annex :G2 schematically shown as a grid, the light pattern should be substantially uniform in so far as the light intensity in each direction of a part of the field formed by the grid lines meets at least the lowest minimum percentage value being shown (available) on the grid lines surrounding the questioned direction.
- G2.App.2.2.3. However in the case where a device is intended to be installed at a mounting height of equal to or less than 750 mm above the ground, the photometric intensity is verified only up to an angle of 5° downwards.

G2.App.2.3. Photometric measurement of lamps

The photometric performance shall be checked:

- G2.App.2.3.1. For non-replaceable light sources (filament lamps and other): with the light sources present in the lamp, in accordance with paragraph G2.2.1. of Annex:G2.
- G2.App.2.3.2. For replaceable filament lamps:
when equipped with filament lamps at 6.75 V, 13.5 V or 28.0 V the luminous intensity values produced shall be corrected. The correction factor is the ratio between the reference luminous flux and the mean value of the luminous flux found at the voltage applied (6.75 V, 13.5 V or 28.0 V). The actual luminous fluxes of each filament lamp used shall not deviate more than $\pm 5\%$ from the mean value. Alternatively a standard filament lamp may be used in turn, in each of the individual positions, operated at its reference flux, the individual measurements in each position being added together.
- G2.App.2.3.3. For any signaling lamp except those equipped with filament lamp(s), the luminous intensities, measured after one minute and after 30 minutes of operation, shall comply with the minimum and maximum requirements. The luminous intensity distribution after one minute of operation can be calculated from the luminous intensity distribution after 30 minutes of operation by applying at each test point the ratio of luminous intensities measured at HV after one minute and after 30 minutes of operation.

ANNEX: G3
(See para G1.1.1)

G3.1. COLOUR OF LIGHT EMITTED

The colour of the light emitted inside the field of the light distribution grid defined in G2.App.2.2.2. of Annex : G2 – Appendix G2, measured by using a source of light with a colour temperature of 2,856 K, corresponding to illuminant A of the International Commission on Illumination (CIE), shall be within the limits of the co-ordinates prescribed for the colour in question given below. Outside this field no sharp variation of colour shall be observed.

However, for lamps equipped with non-replaceable light sources (filament lamps and other), the colorimetric characteristics shall be verified with the light sources present in the lamp, in accordance with paragraph G2.2.1. of Annex : G2.

G3.2. COLOUR OF LIGHT EMITTED TRICHROMATIC CO-ORDINATES

RED	:	limit towards yellow	:	$y \leq 0.335$
		limit towards purple	:	$z \leq 0.008$ or $y \geq 0.980-x$
WHITE	:	limit towards blue	:	$x \geq 0.310$
		limit towards yellow	:	$x \leq 0.500$
		limit towards green	:	$y \leq 0.150 + 0.640 x$
		limit towards green	:	$y \leq 0.440$
		limit towards purple	:	$y \geq 0.050 + 0.750 x$
		limit towards red	:	$y \geq 0.382$
AMBER	:	limit towards yellow or: limit towards green	:	$y \leq 0.429$ or $y \leq 0.335$
		limit towards red	:	$y \geq 0.398$ or $y \geq 0.390$
		limit towards white	:	$z \leq 0.007$ or $y \leq 0.790 - 0.670 x$

For checking those colorimetric characteristics, a source of light at a colour temperature of 2,854 K corresponding to illuminant A of the International Commission on Illumination (CIE) shall be used.

However, for lamps equipped with non-replaceable light sources (filament lamps and other), the colorimetric characteristics should be verified with the light sources present in the lamp, in accordance with paragraph G2.2.1. of Annex : G2.

ANNEX: G 4
(See para 8.0)

**MINIMUM REQUIREMENTS FOR CONFORMITY OF
PRODUCTION CONTROL PROCEDURES**

G4.1. GENERAL

Refer paragraph D4.1. of Annex : D4 with replacing “parking lamp” for “lamp” wherever it appears.

**G4.2. MINIMUM REQUIREMENTS FOR VERIFICATION OF
CONFORMITY BY THE MANUFACTURER**

Refer para A 6.2 of Annex : A 6 with replacing word “parking lamp”for “headlamp” wherever it appears.

G4.2.1. Nature of Tests

Tests of conformity in this standard shall cover the photometric and colorimetric characteristics.

G4.2.2. Methods used in tests

Refer paragraph A 6.2.2 of Annex : A 6 with replacing word “parking lamp” for “headlamp” wherever it appears.

G4.2.3. Nature of Sampling

Refer paragraph A 6.2.3. of Annex : A 6 with replacement of word “parking lamp” for “head lamp” wherever it appears.

G4.2.4. Measured and Recorded Photometric Characteristics

The sampled “parking lamp” shall be subjected to photometric measurements for the minimum values at the points listed in Annex: G2-Appendix:2 and the chromaticity coordinates in para G3.2 of Annex: G3 , provided for in respective Annexes.

G4.2.5. Criteria Governing Acceptability

The manufacturer is responsible for carrying out a statistical study of the test results and for defining, in agreement with the test agency, criteria governing acceptability of his products in order to meet the specification laid down for verification of conformity of products in paragraph 8.1 of this standard.

The criteria governing acceptability shall be such that, with a confidence level of 95%, the minimum probability of passing a spot check in accordance with Annex : G5 (first sampling) would be 0.95.

ANNEX: G 5

(See para 8.0 and G 4.2.5 of Annex: G4)

**MINIMUM REQUIREMENTS FOR SAMPLING BY
AN INSPECTOR**

G5.1. GENERAL

- G5.1.1 Refer paragraph D5.1. 1 of Annex : D5 with replacement of word “parking lamp” for “lamp” wherever it appear.
- G5.1.2 Refer paragraph D5.1. 2 of Annex : D5 with replacement of word “parking lamp” for “lamp” wherever it appear.
- G5.1.2.1 Refer paragraph D5.1. 2.1 of Annex : D5 with replacement of word “parking lamp”for “lamp” wherever it appear.
- G5.1.2.2 If, in the case of a “parking lamp”equipped with a replaceable light source and if results of the test described above do not meet the requirements, test on “parking lamp”shall be repeated using another standard filament lamp.
- G5.1.2.3 Parking lamp with apparent defects are disregarded
- G5.1.3 Refer paragraph D5.1.3 of Annex : D5 with replacement of word “parking lamp” for “lamp” wherever it appear.

G5.2. FIRST SAMPLING

- G5.2.1 The Conformity is Not Contested
- G5.2.1.1 Refer paragraph A7.2 of Annex : A7 with replacement of word “parking lamp” for “headlamp” wherever it appears.
- G5.2.1.1.1 Refer paragraph A7..2.1.1.1. of Annex : A7 with replacing word “parking lamp” for “headlamp” wherever it appears.
- G5.2.1.1.2 Sample B

B1:	Both “parking lamp”		0 %
-----	---------------------	--	-----

- G5.2.1.2. or if the conditions of paragraph G5.1.2.2. for Sample A are fulfilled.
- G5.2.2. The Conformity is Contested
- G5.2.2..1 Refer paragraph A7.2.2.1 of Annex : A7 with replacement of word “parking lamp”for “headlamp” wherever it appears.

G5.2.2.1.1 Refer paragraph A7.2.2.1.1. of Annex : A7 with replacing word “parking lamp” for “headlamp” wherever it appears.

G5.2.2.1.2 **Sample B**

Refer paragraph A7.2.2.1.2. of Annex : A7 with replacing word “parking lamp” for “headlamp” wherever it appears.

G5.2.2.2 or if the conditions of paragraph G5.1.2.2. for sample A are not fulfilled.

G5.2.3. **Approval Withdrawn**

Refer paragraph A7.2.3. of Annex : A7 with replacement of word “parking lamp” for “headlamp” wherever it appears.

G5.2.3.1 **Sample A**

Refer paragraph A7.2.3.1. of Annex : A7 with replacing word “parking lamp” for “headlamp” wherever it appears.

G5.2.3.2. **Sample B**

Refer paragraph A7.2.3.2. of Annex : A7 with replacing word “parking lamp” for “headlamp” wherever it appears.

G5.2.3.3. or if the conditions of paragraph G5.1.2.2. for samples A and B are not fulfilled.

G5.3. REPEATED SAMPLING

Refer paragraph A7.3 of Annex : A7 with replacement of word “parking lamp” for “headlamp” wherever it appears.

G5.3.1. The Conformity is Not Contested

G5.3.1.1. Refer paragraph A7.3.1.1 of Annex : A7 with replacing word “parking lamp” for “headlamp” wherever it appears.

G5.3.1.1.1. **Sample C**

Refer paragraph A7.3.1.1.1. of Annex : A7 with replacing word “parking lamp” for “headlamp” wherever it appears.

G5.3.1.1.2. **Sample D**

D1:	in the case of C2		
	Both “parking lamps”		0%

- G5.3.1.2. or if the conditions of paragraph G5.1.2.2. for sample C are fulfilled.
- G5.3.2. **The Conformity is Contested**
- G5.3.2.1. Refer paragraph A7.3.2.1. of Annex : A7 with replacing word “parking lamp” for “headlamp” wherever it appears.
- G5.3.2.1.1. **Sample D**
Refer paragraph A7.3.2.1.1. of Annex : A7 with replacing word “parking lamp” for “headlamp” wherever it appears.
- G5.3.2.1.2. or if the conditions of paragraph G5.1.2.2 for sample C are not fulfilled.
- G5.3.3. **Approval Withdrawn**
Refer paragraph A7.3.3. of Annex : A7 with replacing word “parking lamp” for “headlamp” wherever it appears.
- G5.3.3.1. **Sample C**
Refer paragraph A7.3.3.1. of Annex : A7 with replacing word “parking lamp” for “headlamp” wherever it appears.
- G5.3.3.2. **Sample D**
Refer paragraph A7.3.3.2. of Annex : A7 with replacing word “parking lamp” for “headlamp” wherever it appears.
- G5.3.3.3. or if the conditions of paragraph G5.1.2.2. for samples C and D are not fulfilled.

ANNEX: H1
(See para 5.8)

REQUIREMENTS FOR SIDE-MARKER LAMPS

H1.1 GENERAL SPECIFICATIONS

- H1.1.1. Each side-marker lamp submitted for approval shall conform to the specifications set out in Annexes : H1,H2,H3 and Annex : L
- H1.1.2. Side-marker lamps shall be so designed and made that, in normal use, despite the vibrations to which they may then be subjected, their satisfactory operation continues to be ensured and they retain the characteristics prescribed by this standard.

ANNEX: H2
(See para H1.1.1)

PHOTOMETRIC TEST PROCEDURE AND INTENSITY REQUIREMENTS FOR SIDE-MARKER LAMP

H2.1. INTENSITY OF LIGHT EMITTED

- H2.1.1. The intensity of the light emitted by each of the two samples submitted shall be:

H2.1.1.1.	Side – marker lamp category		SM 1	SM 2
.	Minimum intensity	In the axis of reference	4.0 cd	0.6 cd
		Within the specified angular field, other than above	0.6 cd	0.6 cd
H2.1.1.2.	Maximum intensity		25.0 cd	25.0 cd
H2.1.1.3	Angular field	Horizontal	± 45 deg.	± 30 deg.
		Vertical	± 10 deg.	± 10 deg.

- H2.1.1.4. In the case of a lamp containing more than one light source:
 - The lamp shall comply with the minimum intensity required when any one light source has failed;
 - When all light sources are illuminated the maximum intensity specified may not be exceeded.
 - All light sources which are connected in series are considered to be one light source.
- H2.1.2. Outside the reference axis and within the angular fields defined in the diagrams in Annex : H2 – Appendix :1 , the intensity of the light emitted by each of the two side-marker lamps supplied must:

- H2.1.2.1. In each direction corresponding to the points in the light distribution table reproduced in Annex:H2 – Appendix:2 to this Annex : H2 (Table : H1 and H2), be not less than the product of the minimum specified in paragraph H 2.1.1. above by the percentage specified in the said table for the direction in question;
- H2.1.2.2. In no direction within the space from which the side-marker lamp is visible, exceed the maximum specified in paragraph H2.1.1. above;
- H2.1.2.3. The provisions of para H2.App.2.2.2.of Annex : H2 – Appendix : H2 on local variations of intensity must be observed.
- H2.1.3. Annex:H2–Appendix:2 , to which reference is made in paragraph H2.1.2.1. above, gives particulars of the measurement methods to be used.

H2.2 TEST PROCEDURE

- H2.2.1. Measurements shall be carried out with a colourless standard filament lamp of the type recommended for the side-marker lamp and so regulated as to produce the reference luminous flux prescribed for this type of lamp, taking into account the provisions of paragraphs H2.2.2. below.
- H2.2.2. All measurements on lamps equipped with non-replaceable light sources (filament lamps and other) shall be made at 6.75 V, 13.5 V or 28.0 V respectively.

In the case of light sources supplied by a special power supply, the above test voltages shall be applied to the input terminals of that power supply. The test laboratory may require from the manufacturer the special power supply needed to supply the light sources.

ANNEX: H2 – APPENDIX: 1
 (See para H2. 1.2)

MINIMUM ANGLES REQUIRED FOR LIGHT DISTRIBUTION IN SPACE

Minimum vertical angles, SM1 And SM2

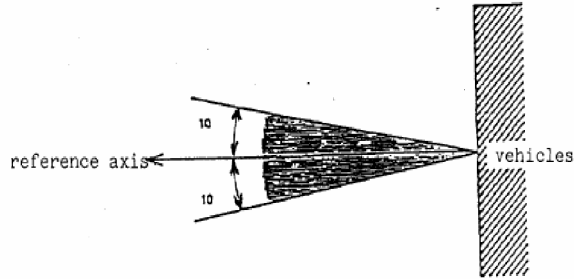

The angle of 10° below the horizontal may be reduced to 5° in case of lamps with a mounting height of equal to or less than 750 mm above the ground.

Minimum horizontal angles, SM1

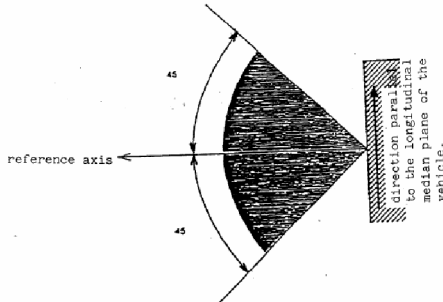

Minimum horizontal angles, SM2

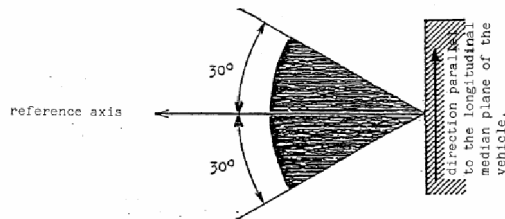

ANNEX: H2 – APPENDIX: 2

(See para H2.1.2.1)

PHOTOMETRIC MEASUREMENTS**H2.APP.2.1. MEASUREMENT METHODS**

H2.App.2.1.1. During photometric measurement stray reflections shall be avoided by appropriate marking.

H2.App.2.1.2. In case the results of measurements should be challenged, measurements shall be carried out in such a way as to meet the following requirements:

H2.App.2.1.2.1. The distance of measurement shall be such that the law of the inverse of the square of the distance is applicable;

H2.App.2.1.2.2. The measuring equipment shall be such that the angular aperture of the receiver viewed from the reference centre of the lamp is comprised between 10 minutes and 1°;

H2.App.2.1.2.3. The intensity requirement for a particular direction of observation shall be deemed to be satisfied if that requirement is met in a direction deviating by not more than one-quarter of a degree from the direction of observation.

H2.App.2.1.3. In the case where the device may be installed on the vehicle in more than one or in a field of different positions the photometric measurements shall be repeated for each position or for the extreme positions of the field of the reference axis specified by the manufacturer.

H2.App.2.1.4. The direction $H = 0^0$ and $V = 0^0$ corresponds to the reference axis. (On the vehicle it is horizontal, perpendicular to the median longitudinal plane of the vehicle and oriented in the required direction of visibility.) It passes through the centre of reference.

H2.APP.2.2. TABLES OF LIGHT DISTRIBUTION

H2.App.2.2.1. SM1 category of side-marker lamps

Table : H1
(See para H2.1.2.1)

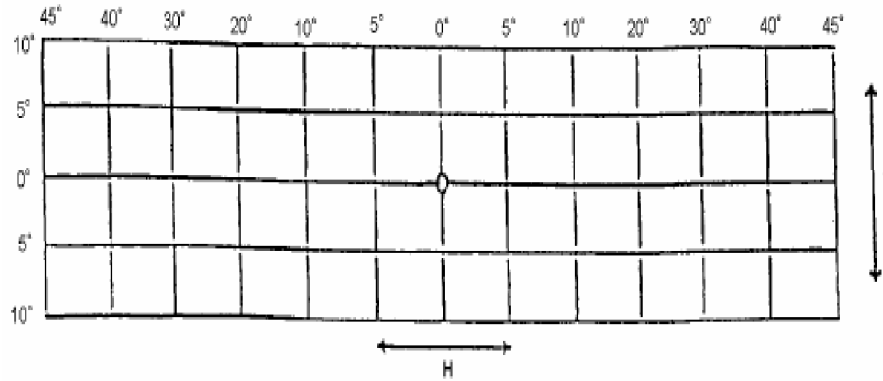

H2.App.2.2.1.1. Minimum values:
0.6 cd at any point other than the reference axis, at which it shall be 4.0 cd.

H2.App.2.2.1.2. Maximum values: 25.0 cd at any point

H2.App.2.2.2. SM2 category of side-marker lamps

Table : H2
(See para H2.1.2.1)

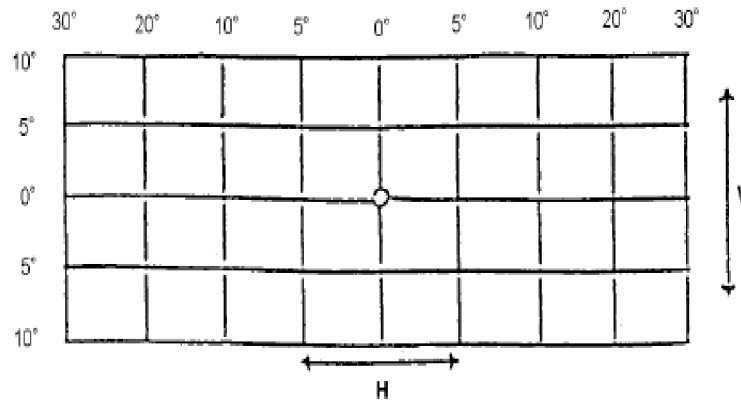

H2.App.2.2.2.1. Minimum values: 0.6 cd, at any point

H2.App.2.2.2.2. Maximum values: 25.0 cd, at any point

H2.App.2.2.3. For SM1 and SM2 category of side-marker lamps it may be sufficient to check only five points selected by the test agency.

H2.App.2.2.4. Within the field of light distribution shown above as a grid the light pattern should be substantially uniform, i.e. the light intensity in every direction within a part of the field formed by the grid lines shall meet at least the lowest minimum value applicable to the respective grid lines.

H2.App.2.2.5. However in the case where a device is intended to be installed at a mounting height of equal to or less than 750 mm above the ground, the photometric intensity is verified only up to an angle of 5° downwards;

H2.App.2.3. Photometric measurement of lamps

The photometric performance shall be checked:

H2.App.2.3.1. For non-replaceable light sources (filament lamps and other):
with the light sources present in the lamp, in accordance with paragraph H2.2.2. of Annex : H2.

H2.App.2.3.2. For replaceable filament lamps:
when equipped with filament lamps at 6.75 V, 13.5 V or 28.0 V the luminous intensity values produced shall be corrected. The correction factor is the ratio between the reference luminous flux and the mean value of the luminous flux found at the voltage applied (6.75 V, 13.5 V or 28.0 V). The actual luminous fluxes of each filament lamp used shall not deviate more than $\pm 5\%$ from the mean value. Alternatively a standard filament lamp may be used in turn, in each of the individual positions, operated at its reference flux, the individual measurements in each position being added together.

H2.App.2.3.3. For any signalling lamp except those equipped with filament lamp(s), the luminous intensities, measured after one minute and after 30 minutes of operation, shall comply with the minimum and maximum requirements. The luminous intensity distribution after one minute of operation can be calculated from the luminous intensity distribution after 30 minutes of operation by applying at each test point the ratio of luminous intensities measured at HV after one minute and after 30 minutes of operation.

ANNEX: H3
(See para H1.1.1)

COLOUR OF LIGHT EMITTED

H3.1. COLOUR OF LIGHT EMITTED

H3.1.1. The side-marker lamp must emit amber light; however it can emit red, if the rearmost side-marker lamp is grouped or combined or reciprocally incorporated with the rear position lamp, the rear end-outline marker lamp, the rear fog lamp, the stop lamp, or is grouped with or has part of the light emitting surface in common with the rear retro-reflector.

H3.1.2. The colour of the light emitted inside the field of the light distribution grid defined in H2.App.2.2.2. of Annex : H2 – Appendix :H2 must be within the limits of the trichromatic coordinates prescribed for the colour in question given below. Outside this field no sharp variation of colour shall be observed.

**H3.2 COLOUR OF LIGHT EMITTED:
LIGHTS FOR TRICHROMATIC COORDINATES**

Amber	:	limit towards yellow or limit towards green	:	$y \leq 0.429$ or $y \leq x - 0.120$
		limit towards red	:	$y \geq 0.398$ or $y \geq 0.390$
		limit towards white	:	$z \leq 0.007$ or $y \leq 0.790 - 0.670 x$
Red	:	limit towards yellow	:	$y \leq 0.335$
		limit towards purple	:	$z \leq 0.008$ or $y \geq 0.980 - x$

For checking these colorimetric characteristics, a source of light at a colour temperature of 2,856 K, corresponding to illuminant A of the International Commission on Illumination (CIE), shall be used. However, for lamps equipped with non-replaceable light sources (filament lamps and other), the colorimetric characteristics should be verified with the light sources present in the lamp, in accordance with paragraph H2.2.2. of Annex : H2.

ANNEX: H 4
(See para 8.0)

**MINIMUM REQUIREMENTS FOR CONFORMITY OF
PRODUCTION CONTROL PROCEDURES**

H4.1. GENERAL

Refer paragraph D4.1. of Annex : D4 with replacing “side-marker lamp” for “lamp” wherever it appears.

**H4.2. MINIMUM REQUIREMENTS FOR VERIFICATION OF
CONFORMITY BY THE MANUFACTURER**

Refer para A 6.2 of Annex : A 6 with replacing word “side-marker lamp” for “headlamp” wherever it appears.

H4.2.1. Nature of Tests

Tests of conformity in this standard shall cover the photometric and colorimetric characteristics.

H4.2.2. Methods used in Tests

Refer paragraph A 6.2.2 of Annex : A 6 with replacing word “side-marker lamp” for “headlamp” wherever it appears.

H4.2.3. Nature of Sampling

Refer paragraph A 6.2.3. of Annex : A 6 with replacement of word “side-marker lamp” for “head lamp” wherever it appears.

H4.2.4 . Measured and Recorded Photometric Characteristics

The sampled “side-marker lamp” shall be subjected to photometric measurements for the minimum values at the points listed in Annex: H2-Appendix :2 and the chromaticity coordinates in para H3.2 of Annex: H3 , provided for in respective Annexes.

H4.2.5. Criteria Governing Acceptability

The manufacturer is responsible for carrying out a statistical study of the test results and for defining, in agreement with the test agency, criteria governing acceptability of his products in order to meet the specification laid down for verification of conformity of products in paragraph 8.1 of this standard.

The criteria governing acceptability shall be such that, with a confidence level of 95%, the minimum probability of passing a spot check in accordance with Annex : H5 (first sampling) would be 0.95.

ANNEX: H 5
(See para 8.0 and H4.2.5 of Annex: H4)

**MINIMUM REQUIREMENTS FOR
SAMPLING BY AN INSPECTOR**

H5.1. GENERAL

- H5.1.1 Refer paragraph D5.1. 1 of Annex : D5 with replacement of word “side-marker lamp” for “lamp” wherever it appear.
- H5.1.2 Refer paragraph D5.1. 2 of Annex : D5 with replacement of word “side-marker lamp” for “lamp” wherever it appear.
- H5.1.2.1 Refer paragraph D5.1. 2.1 of Annex : D5 with replacement of word “side-marker lamp” for “lamp” wherever it appear.
- H5.1.2.2 If, in the case of a “side-marker lamp” equipped with a replaceable light source and if results of the test described above do not meet the requirements, test on “side-marker lamp” shall be repeated using another standard filament lamp.
- H5.1.2.3 “side-marker lamp” with apparent defects are disregarded
- H5.1.3 Refer paragraph D5.1.3 of Annex : D5 with replacement of word “side-marker lamp” for “lamp” wherever it appear.

H5.2. FIRST SAMPLING

H5.2.1 The Conformity is Not Contested

- H5.2.1.1 Refer paragraph A7.2 of Annex : A7 with replacement of word “side-marker lamp” for “headlamp” wherever it appears.
- H5.2.1.1.1 Refer paragraph A7.2.1.1.1. of Annex : A7 with replacing word “side-marker lamp” for “headlamp” wherever it appears.

H5.2.1.1.2 Sample B

B1:	Both “side-marker lamps”		0 %
-----	--------------------------	--	-----

- H5.2.1.2. or if the conditions of paragraph H5.1.2.2. for Sample A are fulfilled.

H5.2.2. The Conformity is Contested

- H5.2.2.1 Refer paragraph A7.2.2.1 of Annex : A7 with replacement of word “side-marker lamp” for “headlamp” wherever it appears.

- H5.2.2.1.1 Refer paragraph A7.2.2.1.1. of Annex : A7 with replacing word “side-marker lamp” for “headlamp” wherever it appears.
- H5.2.2.1.2 **Sample B**
Refer paragraph A7.2.2.1.2. of Annex : A7 with replacing word “side-marker lamp” for “headlamp” wherever it appears.
- H5.2.2.2 or if the conditions of paragraph H5.1.2.2. for sample A are not fulfilled.

H5.2.3. **Approval Withdrawn**

Refer paragraph A7.2.3. of Annex : A7 with replacement of word “side-marker lamp” for “headlamp” wherever it appears.

H5.2.3.1 **Sample A**

Refer paragraph A7.2.3.1. of Annex : A7 with replacing word “side-marker lamp” for “headlamp” wherever it appears.

H5.2.3.2. **Sample B**

Refer paragraph A7.2.3.2. of Annex : A7 with replacing word “side-marker lamp” for “headlamp” wherever it appears.

H5.2.3.3. or if the conditions of paragraph H5.1.2.2. for samples A and B are not fulfilled.

H5.3. REPEATED SAMPLING

Refer paragraph A7.3 of Annex : A7 with replacement of word “side-marker lamp” for “headlamp” wherever it appears.

H5.3.1. **The Conformity is Not Contested**

H5.3.1.1. Refer paragraph A7.3.1.1 of Annex : A7 with replacing word “side-marker lamp” for “headlamp” wherever it appears.

H5.3.1.1.1. **Sample C**

Refer paragraph A7.3.1.1.1. of Annex : A7 with replacing word “side-marker lamp” for “headlamp” wherever it appears.

H5.3.1.1.2. **Sample D**

D1:	in the case of C2		
	Both “side-marker lamps”		0%

H5.3.1.2. or if the conditions of paragraph H5.1.2.2. for sample C are fulfilled.

H5.3.2. **The Conformity is Contested**

H5.3.2.1. Refer paragraph A7.3.2.1. of Annex : A7 with replacing word “side-marker lamp” for “headlamp” wherever it appears.

H5.3.2.1.1. **Sample D**

Refer paragraph A7.3.2.1.1. of Annex : A7 with replacing word “side-marker lamp” for “headlamp” wherever it appears.

- H5.3.2.1.2. or if the conditions of paragraph H5.1.2.2 for sample C are not fulfilled.

- H5.3.3. **Approval Withdrawn**

Refer paragraph A7.3.3. of Annex : A7 with replacing word “side-marker lamp” for “headlamp” wherever it appears.

- H5.3.3.1. **Sample C**
Refer paragraph A7.3.3.1. of Annex : A7 with replacing word “side-marker lamp” for “headlamp” wherever it appears.

- H5.3.3.2. **Sample D**
Refer paragraph A7.3.3.2. of Annex : A7with replacing word “side-marker lamp” for “headlamp” wherever it appears.

- H5.3.3.3. or if the conditions of paragraph H5.1.2.2. for samples C and D are not fulfilled.

ANNEX: J1
(See para 5.9)

REQUIREMENTS FOR REAR FOG LAMPS

J1.1 GENERAL SPECIFICATIONS

J1.1.1 Each sample shall conform to the specifications set forth in the Annexes:J1, J2, J3 and Annex : L

J1.1.2. Rear fog lamps shall be so designed and constructed that in normal use, despite the vibration to which they may then be subjected, they continue to function satisfactorily and retain the characteristics prescribed by this standard.

ANNEX: J2
(See para J1.1.1)

**PHOTOMETRIC TEST PROCEDURE AND INTENSITY
REQUIREMENTS FOR REAR FOG LAMPS**

J2.1 INTENSITY OF LIGHT EMITTED

- J2.1.1. The intensity of the light emitted by each of the two samples shall be not less than the minima and not greater than the maxima specified below and shall be measured in relation to the axis of references in the directions shown below (expressed in degrees of angle with the axis of reference).
- J2.1.2. The intensity along the H and V axes, between 10⁰ to the left and 10⁰ to the right and between 5⁰ up and 5⁰ down, shall not be less than 150 cd.
- J2.1.3 The intensity of the light emitted in all directions in which the light(s) can be observed shall not exceed 300 cd per light.
- J2.1.4 In the case of a single lamp containing more than one light source, the lamp shall comply with the minimum intensity required when any one light source has failed and when all light sources are illuminated the maximum intensities shall not be exceeded.
- J2.1.5 The apparent surface in the direction of the reference axis shall not exceed 140 cm².
- J2.1.6 Annex : J2 – Appendix :1 gives particulars of the measurement method to be used in case of doubt.

J2.2. TEST PROCEDURE

All measurements shall be carried out with uncoloured standard lamps of the types prescribed for the device, adjusted to produce the normal luminous flux prescribed for those types of lamps.

- J2.2.1. All measurements on lamps equipped with non-replaceable light sources (filament lamps and other) shall be made at 6.75 V, 13.5 V or 28.0 V respectively.

In the case of light sources supplied by a special power supply, the above test voltages shall be applied to the input terminals of that power supply. The test laboratory may require from the manufacturer the special power supply needed to supply the light sources.

J2.3. HEAT RESISTANCE TEST

- J2.3.1 The lamp must be subjected to a one-hour test of continuous operation following a warm-up period of 20 minutes. The ambient temperature shall be $23^{\circ}\text{C} \pm 5^{\circ}\text{C}$. The lamp used shall be a lamp of the category prescribed for the lamp, and shall be supplied with a current at a voltage such that it gives the specified average power at the corresponding test voltage.
- J2.3.2. Where only the maximum power is specified, the test shall be carried out by regulating the voltage to obtain a power equal to 90% of the specified power. The specified average or maximum power referred to above shall in all cases be chosen from the voltage range of 6, 12 or 24 V at which it reaches the highest value.
- J2.3.3. After the lamp has been stabilized at the ambient temperature, no distortion, deformation, cracking or color modification shall be perceptible.

ANNEX: J2 – APPENDIX: 1

(See para J2.1.6)

PHOTOMETRIC MEASUREMENTS

- J2.App.1.1. When photometric measurements are taken, stray reflexions shall be avoided by appropriate masking.
- J2.App.1.2. In the event that the results of measurements are challenged, measurements shall be taken in such a way as to meet the following requirements:
- J2.App.1.2.1. The distance of measurement shall be such that the law of the inverse of the square of the distance is applicable;
- J2.App.1.2.2. The measuring equipment shall be such that the angle subtended by the receiver from the reference centre of the light is between 10' and 1 degree;
- J2.App.1.2.3 the intensity requirement for a particular direction of observation shall be satisfied if the required intensity is obtained in a direction deviating by not more than one-quarter of a degree from the direction of observation.
- J2.App.1.3. In the case where the device may be installed on the vehicle in more than one or in a field of different positions the photometric measurements shall be repeated for each position or for the extreme positions of the field of the reference axis specified by the manufacturer.
- J2.App.1.4. If visual examination of a light appears to reveal substantial local variations of intensity, a check shall be made to ensure that, outside the axes, no intensity measured within the rhombus defined by the extreme directions of measurement is below 75 cd (see diagram below).

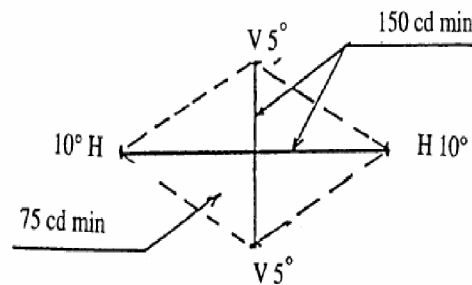

J2.App.1.5. **Photometric Measurement of Lamps Equipped with Several Light Sources**

The photometric performance shall be checked:

J2.App.1.5.1. For non-replaceable light sources (filament lamps and other):
with the light sources present in the lamp, in accordance with paragraph J2.2.1. of this Annex : J2.

J2.App.1.5.2. For replaceable filament lamps:
when equipped with filament lamps at 6.75 V, 13.5 V or 28.0 V, the luminous intensity values produced shall be corrected. The correction factor is the ratio between the reference luminous flux and the mean value of the luminous flux found at the voltage applied (6.75 V, 13.5 V or 28.0 V). The actual luminous fluxes of each filament lamp used shall not deviate more than $\pm 5\%$ from the mean value. Alternatively a standard filament lamp may be used in turn, in each of the individual positions, operated at its reference flux, the individual measurements in each position being added together.

ANNEX: J3
(See para J1.1.1)

COLOUR OF LIGHT EMITTED

J3.1. COLOUR OF LIGHT EMITTED

The color of the light emitted inside the field of the light distribution grid defined at paragraph J2.App.1.4 Annex : J2 – Appendix :1, which shall be measured by using a source of light at a color temperature of 2854 K,⁽¹⁾ must lie within the limits of the following trichromatic coordinates:

limit towards yellow	:	$y \leq 0.335$
limit towards purple	:	$z \leq 0.008$ or $y \geq 0.980-x$

O

outside this field no sharp variation of colour shall be observed.

However, for lamps equipped with non-replaceable light sources (filament lamps and other), the colorimetric characteristics should be verified with the light sources present in the lamp, in accordance with paragraph J2.2.1. of Annex : J2.

(1) Corresponding to illuminant A of the International Commission on Illumination (ICI).

ANNEX: J 4
(See para 8.0)

**MINIMUM REQUIREMENTS FOR CONFORMITY OF
PRODUCTION CONTROL PROCEDURES**

J4.1. GENERAL

Refer paragraph D4.1. of Annex : D4 with replacing “rear fog lamp” for “lamp” wherever it appears.

**J4.2. MINIMUM REQUIREMENTS FOR VERIFICATION OF
CONFORMITY BY THE MANUFACTURER**

Refer para A 6.2 of Annex : A 6 with replacing word “rear fog lamp” for “headlamp” wherever it appears.

J4.2.1. Nature of Tests

Tests of conformity in this standard shall cover the photometric and colorimetric characteristics.

J4.2.2. Methods used in tests

Refer paragraph A 6.2.2 of Annex : A 6 with replacing word “rear fog lamp” for “headlamp” wherever it appears.

J4.2.3. Nature of Sampling

Refer paragraph A 6.2.3. of Annex : A 6 with replacement of word “rear fog lamp” for “head lamp” wherever it appears.

J4.2.4. Measured and Recorded Photometric Characteristics

The sampled “rear fog lamp” shall be subjected to photometric measurements for the minimum values at the points listed in Annex: J2-Appendix :1 and the chromaticity coordinates in para J3.2 of Annex: J3 , provided for in respective Annexes.

J4.2.5. Criteria Governing Acceptability

The manufacturer is responsible for carrying out a statistical study of the test results and for defining, in agreement with the test agency, criteria governing acceptability of his products in order to meet the specification laid down for verification of conformity of products in paragraph 8.1 of this standard.

The criteria governing acceptability shall be such that, with a confidence level of 95%, the minimum probability of passing a spot check in accordance with Annex : J5 (first sampling) would be 0.95.

Annex: J 5

(See para 8.0 and J 4.2.5 of Annex: J4)

MINIMUM REQUIREMENTS FOR SAMPLING BY AN INSPECTOR

J5.1. GENERAL

- J5.1.1 Refer paragraph D5.1. 1 of Annex : D5 with replacement of word “rear fog lamp” for “lamp” wherever it appear.
- J5.1.2 Refer paragraph D5.1. 2 of Annex : D5 with replacement of word “rear fog lamp” for “lamp” wherever it appear.
- J5.1.2.1 Refer paragraph D5.1. 2.1 of Annex : D5 with replacement of word “rear fog lamp” for “lamp” wherever it appear.
- J5.1.2.2 If, in the case of a “rear fog lamp” equipped with a replaceable light source and if results of the test described above do not meet the requirements, test on “rear fog lamp” shall be repeated using another standard filament lamp.
- J5.1.2.3 Rear fog lamp with apparent defects are disregarded
- J5.1.3 Refer paragraph D5.1.3 of Annex : D5 with replacement of word “rear fog lamp” for “lamp” wherever it appear.

J5.2. FIRST SAMPLING

- J5.2.1 The Conformity is Not Contested
- J5.2.1.1 Refer paragraph A7.2 of Annex : A7 with replacement of word “rear fog lamp” for “headlamp” wherever it appears.
- J5.2.1.1.1 Refer paragraph A7..2.1.1.1. of Annex : A7 with replacing word “rear fog lamp” for “headlamp” wherever it appears.

J5.2.1.1.2 Sample B

B1:	Both “rear fog lamps”		0 %
-----	-----------------------	--	-----

- J5.2.1.2. or if the conditions of paragraph J5.1.2.2. for Sample A are fulfilled.

J5.2.2. The Conformity is Contested

- J5.2.2..1 Refer paragraph A7.2.2.1 of Annex : A7 with replacement of word “rear fog lamp” for “headlamp” wherever it appears.

J5.2.2.1.1 Refer paragraph A7.2.2.1.1. of Annex : A7 with replacing word “rear fog lamp” for “headlamp” wherever it appears.

J5.2.2.1.2 **Sample B**

Refer paragraph A7.2.2.1.2. of Annex : A7 with replacing word “rear fog lamp” for “headlamp” wherever it appears.

J5.2.2.2 or if the conditions of paragraph J5.1.2.2. for sample A are not fulfilled.

J5.2.3. **Approval Withdrawn**

Refer paragraph A7.2.3. of Annex : A7 with replacement of word “rear fog lamp” for “headlamp” wherever it appears.

J5.2.3.1 **Sample A**

Refer paragraph A7.2.3.1. of Annex : A7 with replacing word “rear fog lamp” for “headlamp” wherever it appears.

J5.2.3.2. **Sample B**

Refer paragraph A7.2.3.2. of Annex : A7 with replacing word “rear fog lamp” for “headlamp” wherever it appears.

J5.2.3.3. or if the conditions of paragraph J5.1.2.2. for samples A and B are not fulfilled.

J5.3. REPEATED SAMPLING

Refer paragraph A7.3 of Annex : A7 with replacement of word “rear fog lamp” for “headlamp” wherever it appears.

J5.3.1. **The Conformity is Not Contested**

J5.3.1.1. Refer paragraph A7.3.1.1 of Annex : A7 with replacing word “rear fog lamp” for “headlamp” wherever it appears.

J5.3.1.1.1. **Sample C**

Refer paragraph A7.3.1.1.1. of Annex : A7 with replacing word “rear fog lamp” for “headlamp” wherever it appears.

J5.3.1.1.2. **Sample D**

D1:	in the case of C2		
	Both “rear fog lamps		0%

J5.3.1.2. or if the conditions of paragraph J5.1.2.2. for sample C are fulfilled.

J5.3.2. **The Conformity is Contested**

J5.3.2.1. Refer paragraph A7.3.2.1. of Annex : A7 with replacing word “rear fog lamp” for “headlamp” wherever it appears.

J5.3.2.1.1. **Sample D**

Refer paragraph A7.3.2.1.1. of Annex : A7 with replacing word “rear fog lamp” for “headlamp” wherever it appears.

J5.3.2.1.2. or if the conditions of paragraph J5.1.2.2 for sample C are not fulfilled.

J5.3.3. **Approval Withdrawn**

Refer paragraph A7.3.3. of Annex : A7 with replacing word “rear fog lamp” for “headlamp” wherever it appears.

J5.3.3.1. **Sample C**

Refer paragraph A7.3.3.1. of Annex : A7 with replacing word “rear fog lamp” for “headlamp” wherever it appears.

J5.3.3.2. **Sample D**

Refer paragraph A7.3.3.2. of Annex : A7 with replacing word “rear fog lamp” for “headlamp” wherever it appears.

J5.3.3.3. or if the conditions of paragraph J5.1.2.2. for samples C and D are not fulfilled.

ANNEX: K1
(See Para 5.10)

**REQUIREMENTS FOR REAR REGISTRATION PLATE
(MARK) ILLUMINATING LAMP**

K1. GENERAL SPECIFICATIONS

- K1.1. Each sample shall conform to the lighting specifications set forth in a paragraph K4 below. ⁽¹⁾

Illuminating devices must be so designed that the entire surface to be illuminated is visible from the rear within the field of vision indicated in the drawing in Annex :K2.

- K1.2. All measurements shall be carried out by adjusting the lamp or lamps of the illuminating device to the minimum light flux prescribed for the test voltage in the specification of the lamp or lamps for the device.

- K1.2.1. All measurements on lamps equipped with non-replaceable light sources (filament lamps and other) shall be made at 6.75 V, 13.5 V or 28.0 V respectively.

In the case of light sources supplied by a special power supply, the above test voltages shall be applied to the input terminals of that power supply. The test laboratory may require from the manufacturer the special power needed to supply the light sources.

- K1.3. For any rear registration plate(mark) illuminating device, except those equipped with filament lamp(s), the luminance values measured after one minute and after 30 minutes of operation shall comply with the minimum requirements.

The luminance distribution after one minute of operation can be calculated by applying at each test point the ratio of luminance values measured in one point after one minute and after 30 minutes of operation.

K2. COLOUR OF LIGHT

The light of the lamp used in the illuminating device must be sufficiently colourless not to cause any appreciable change in the colour of the registration plate.

(1) These specifications are such as to ensure good visibility if the inclination of the registration plate does not exceed 30 degrees on either side of the vertical.

K3. MEASURING PROCEDURE

Luminance measurements shall be made on a piece of clean white blotting paper with a minimum diffuse reflection factor of 70%, of the same dimensions as the registration plate, placed in the position normally occupied by it and 2 mm in front of its holder.

Luminance measurements shall be made perpendicularly to the surface of the paper, at the points shown in Annex :K3 according to the type of plate for which the device is intended, each point representing a circular area 25 mm in diameter.

K4. PHOTOMETRIC CHARACTERISTICS

At each of the points of measurement shown in Annex : K3, the luminance B shall be at least equal to 2.5 cd/m². The gradient of the luminance between the values B1 and B2, measured at any two points 1 and 2 selected from among those mentioned above, shall not exceed 2 x Bo/cm, Bo being the minimum luminance measured at the various points, that is to say:

$$\frac{B_2 - B_1}{\text{distance 1-2 in cm}} \leq 2 \times B_0/\text{cm}$$

K5. ANGLE OF INCIDENCE

The manufacturer of the illuminating device shall specify one or more or field of position in which the device is to be fitted in relation to the space for the registration plate; when the lamp is placed in the position(s) specified by the manufacturer the angle of incidence of the light on the surface of the plate does not exceed 82° at any point on the surface to be illuminated, this angle being measured from the extremity of the device's illuminating area which is furthest from the surface of the plate. If there is more than one illuminating device, the foregoing requirement shall apply only to that part of the plate intended to be illuminated by the device concerned.

The device must be so designed that no light is emitted directly towards the rear, with the exception of red light if the device is combined or grouped with a rear lamp.

**K6. PHOTOMETRIC MEASUREMENT OF LAMPS EQUIPITED
WITH SEVERAL LIGHT SOURCES**

K6.1 The photometric performance shall be checked:

K6.1.1 For non - replaceable light sources (filament lamps & other) :
With the light sources present in the lamp, in accordance with
paragraph K1.2.1. of Annex : K1

K6.1.2. For Replaceable Filament Lamp :

When equipped with mass production filament lamps at 6.75 V, 13.5 V or 28.0 V, the luminous intensity values produced shall lie between the maximum limit given in this standard & minimum limit of this standard increased according to the permissible deviation of the luminous flux permitted for the type of filament lamp chosen, as stated in AIS 034 for production filament lamps; alternatively a standard filament lamp may be used in turn, in each of the individual positions, operated at its reference flux, the individual measurements in each position being added together.

ANNEX : K2
 (See para K1.1)
**MINIMUM FIELD OF VISIBILITY OF THE SURFACE
 TO BE ILLUMINATED**

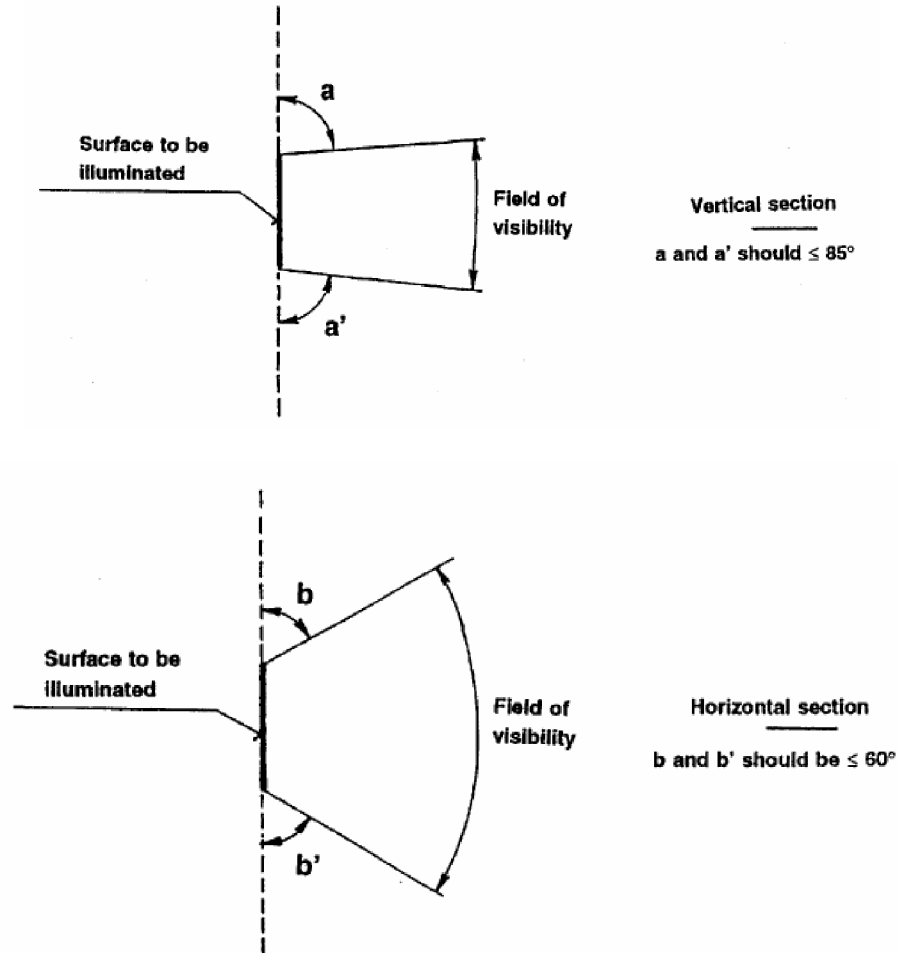

- K2.1** The field-of-visibility angles shown above relate only to the relative positions of the illuminating device and the space for the registration plate.
- K2.2** The field of visibility of the registration plate when mounted on the vehicle remains subject to the relevant national regulations.
- K2.3** The angles shown take account of the partial occultation caused by the illuminating device. They must be adhered to in the directions in which there is most occultation. The illuminating devices must be such as to reduce the areas partly occulted to the minimum strictly necessary.

ANNEX : K3
(See para K3)

MEASUREMENT POINTS FOR TEST PURPOSES

a) Devices for Illuminating a Tall Plate (340 x 200 mm)

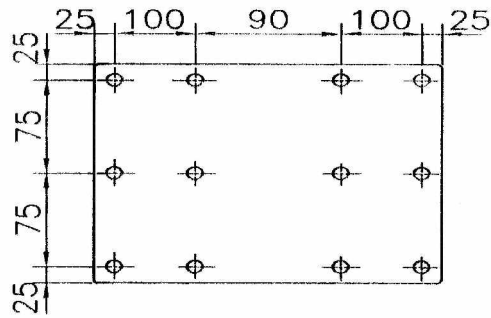

b) Devices for Illuminating a Wide Plate (500 x 120 mm)

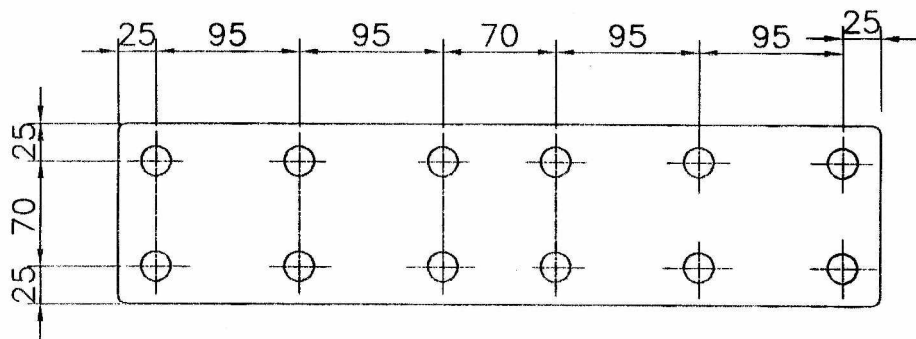

Note : In the case of devices for illuminating two or all of the plates the measurement points used are obtained by combining the two drawings above in accordance with the outline indicated by the make or manufacturer; however if two measurement points are less than 30 mm apart, only one shall be used.

ANNEX: K4
(See para 8.0)

**MINIMUM REQUIREMENTS FOR CONFORMITY OF
PRODUCTION CONTROL PROCEDURES**

K4.1. GENERAL

K4.1.1 Refer paragraph D4.1.1 of Annex : D4 with replacing “rear registration plate (mark) illuminating lamp” for “lamp” wherever it appears.

K4.1.2 Refer paragraph D4.1.2 of Annex : D4 with replacing “rear registration plate (mark) illuminating lamp” for “lamp” wherever it appears.

K4.1.2.1 No measured value deviates unfavourably by more than 20% from the values prescribed in respective Annex

K4.1.2.2 with respect to the gradient of luminance the unfavourable deviation may be;

2.5x Bo/cm comparable to 20%

3.0x Bo/cm comparable to 30%

K4.1.2.3 Refer paragraph D4.1.2.2 of Annex : D4 with replacing “rear registration plate (mark) illuminating lamp” for “lamp” wherever it appears.

**K4.2. MINIMUM REQUIREMENTS FOR VERIFICATION OF
CONFORMITY BY THE MANUFACTURER**

Refer para A 6.2 of Annex : A 6 with replacing word “rear registration plate (mark) illuminating lamp” for “headlamp” wherever it appears.

K4.2.1. Nature of Tests

Tests of conformity in relevant Annexes shall cover the photometric characteristics.

K4.2.2. Methods used in tests

Refer paragraph A 6.2.2 of Annex : A 6 with replacing word “rear registration plate (mark) illuminating lamp” for “headlamp” wherever it appears.

K4.2.3. Nature of Sampling

Refer paragraph A 6.2.3. of Annex : A 6 with replacement of word “rear registration plate (mark) illuminating lamp” for “head lamp” wherever it appears.

K4.2.4. Measured and Recorded Photometric Characteristics

The sampled device shall be subjected to photometric measurement provided for in relevant Annex

K4.2.5. Criteria Governing Acceptability

The manufacturer is responsible for carrying out a statistical study of the test results and for defining, in agreement with the test agency, criteria governing acceptability of his products in order to meet the specification laid down for verification of conformity of products in paragraph 8.1 of this standard.

The criteria governing acceptability shall be such that, with a confidence level of 95%, the minimum probability of passing a spot check in accordance with Annex : K5 (first sampling) would be 0.95.

ANNEX: K 5

(See para 8.0 and K4.2.5 of Annex: K4)

**MINIMUM REQUIREMENTS FOR
SAMPLING BY AN INSPECTOR****K5.1. GENERAL**

K5.1.1 Refer paragraph D5.1. 1 of Annex : D5 with replacement of word “rear registration plate (mark) illuminating lamp”for “lamp” wherever it appear.

K5.1.2 Refer paragraph D5.1. 2 of Annex : D5 with replacement of word “rear registration plate (mark) illuminating lamp”for “lamp” wherever it appear.

K5.1.2.1 Refer paragraph D5.1. 2.1 of Annex : D5 with replacement of word “rear registration plate (mark) illuminating lamp”for “lamp” wherever it appear.

K5.1.2.2 with respect to the gradient of luminance the unfavourable deviation may be;

2.5x Bo/cm comparable to 20%

3.0x Bo/cm comparable to 30%

K5.1.2.3 If, in the case of a “rear registration plate (mark) illuminating lamp”equipped with a replaceable light source and if results of the test described above do not meet the requirements, test on direction indicator shall be repeated using another standard filament lamp.

K5.1.2.4 “rear registration plate (mark) illuminating lamp”with apparent defects are disregarded

K5.2. FIRST SAMPLING**K5.2.1 The Conformity is Not Contested**

K5.2.1.1 Refer paragraph A7.2 of Annex : A7 with replacement of word “rear registration plate (mark) illuminating lamp”for “headlamp” wherever it appears.

K5.2.1.1.1 Refer paragraph A7..2.1.1.1. of Annex : A7 with replacing word “rear registration plate (mark) illuminating lamp”for “headlamp” wherever it appears.

K5.2.1.1.2 **Sample B**

B1:	Both “rear registration plate (mark) illuminating lamps”		0 %
-----	---	--	-----

K5.2.2. **The Conformity is Contested**

K5.2.2.1 Refer paragraph A7.2.2.1 of Annex : A7 with replacement of word “rear registration plate (mark) illuminating lamp” for “headlamp” wherever it appears.

K5.2.2.1.1 Refer paragraph A7.2.2.1.1. of Annex : A7 with replacing word “rear registration plate (mark) illuminating lamp” for “headlamp” wherever it appears.

K5.2.2.1.2 **Sample B**

Refer paragraph A7.2.2.1.2. of Annex : A7 with replacing word “rear registration plate (mark) illuminating lamp”for “headlamp” wherever it appears.

K5.2.3. **Approval Withdrawn**

Refer paragraph A7.2.3. of Annex : A7 with replacement of word “rear registration plate (mark) illuminating lamp” for “headlamp” wherever it appears.

K5.2.3.1 **Sample A**

Refer paragraph A7.2.3.1. of Annex : A7 with replacing word “rear registration plate (mark) illuminating lamp” for “headlamp” wherever it appears.

K5.2.3.2. **Sample B**

Refer paragraph A7.2.3.2. of Annex : A7 with replacing word “rear registration plate (mark) illuminating lamp”for “headlamp” wherever it appears.

K5.3. REPEATED SAMPLING

Refer paragraph A7.3 of Annex : A7 with replacement of word “rear registration plate (mark) illuminating lamp”for “headlamp” wherever it appears.

K5.3.1 . The Conformity is Not Contested

K5.3.1.1. Refer paragraph A7.3.1.1 of Annex : A7 with replacing word “rear registration plate (mark) illuminating lamp”for “headlamp” wherever it appears.

K12.3.1.1.1. Sample C

Refer paragraph A7.3.1.1.1. of Annex : A7 with replacing word “rear registration plate (mark) illuminating lamp”for “headlamp” wherever it appears.

K5.3.1.1.2. Sample D

D1:	in the case of C2		
	Both rear registration plate (mark) illuminating lamps		0%

K5.3.2. The Conformity is Contested

K5.3.2.1. Refer paragraph A7.3.2.1. of Annex : A7 with replacing word “rear registration plate (mark) illuminating lamp”for “headlamp” wherever it appears.

K5.3.2.1.1. Sample D

Refer paragraph A7.3.2.1.1. of Annex : A7 with replacing word “rear registration plate (mark) illuminating lamp”for “headlamp” wherever it appears.

K5.3.3. Approval Withdrawn

Refer paragraph A7.3.3. of Annex : A7 with replacing word “rear registration plate (mark) illuminating lamp”for “headlamp” wherever it appears.

K5.3.3.1. Sample C

Refer paragraph A7.3.3.1. of Annex : A7 with replacing word “rear registration plate (mark) illuminating lamp”for “headlamp” wherever it appears.

K5.3.3.2. Sample D

Refer paragraph A7.3.3.2. of Annex : A7with replacing word “rear registration plate (mark) illuminating lamp”for “headlamp” wherever it appears.

ANNEX : L
(See para 6.2)

ENVIRONMENTAL TESTS

- L1** The following are the procedures and requirements for environmental tests. The applicability of the tests are as given in the Table - 1.
- L2.0** **Vibration Test**
- L2.1 The test specimen mounted on a suitable support shall be rigidly fixed on a suitable vibrating machine constructed to produce simple harmonic function (a total amplitude of 1.5 mm) and shall be subjected to vibration through a frequency range of 10-55-10 Hz in a period of 1 minute with continuously varying frequencies. The vibration shall be applied for not less than 1 hour in the directions of each of the 3 major axes of the light.
- L2.3 At the end of the vibration test, the test specimen shall not show evidence of material defects, lens or reflector rotation, displacement or rupture of parts except filaments lamp failures.
- L3.0** **Corrosion Resistance Test**
- L3.1** **Apparatus : Salt Spray Chamber**
- L3.1.1 The chamber for this test shall be so constructed that the salt spray is produced in the lower part of the chamber, in the upper part of which the parts to be exposed are suspended.
- L3.1.2 The construction of the ceiling walls and other parts of the chamber shall be such that no condensate can drip on the test specimen. The spray shall be produced by an atomizer employing compressed air free from all impurities.
- L3.1.3 In general, a salt spray chamber shown in **Figure L1**, with a spraying arrangement as shown in Figure L2 and complying with the following requirements would be suitable.
- L3.1.4 The cabinet shall approximately be of the dimensions shown, and the cabinet and its internal fittings shall be made of monel metal or other suitable material. A shelf capable of being fitted in the upper or lower part of the cabinet shall be provided.
- L3.1.5 The air used for atomizing the salt solution shall be clean. It shall be possible to adjust the pressure by a relief valve or by the pressure outlet of the blower.
- L3.1.6 It shall be possible to control the amount of spray by adjusting the position of the lower nozzle C by unscrewing the bottom lock-nut B. The diameter of nozzle shall be 1.5 mm. A tap and second branch in the air-line shall be available for agitating the salt solution as required.
- L3.1.7 The spraying apparatus shall be capable of atomizing not less than 1450 ml salt solution per hour. The quantity of solution sprayed per cubic meter capacity of the chamber shall be approximately 175 ml per minute.
- L3.1.8 A container filled with cotton wool shall be provided as shown in fig. L1. It acts as breather and provides an outlet for the air which is constantly being pumped into the chamber, the cotton wool acting as a filter and preventing salt mist from being discharged into the atmosphere.

Figure L1. Salt Spray Chamber (See L3.1.3)

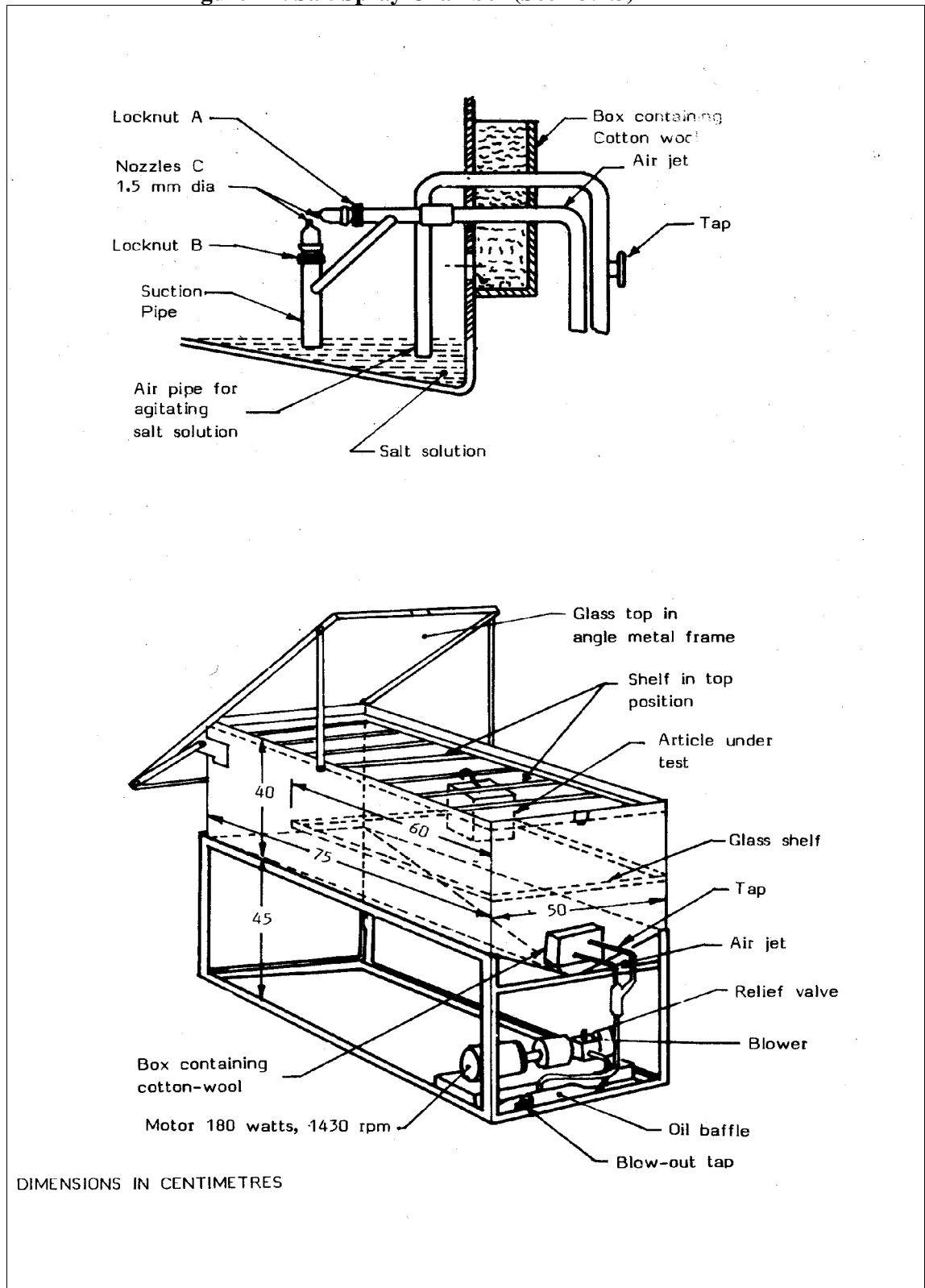

Figure L2. Details of spraying equipment (See L3.1.3)

L3.2 Procedure

The nozzle for atomizing the salt solution shall be adjusted for maximum amount of spray. The pressure of the solution shall be maintained between 29 and 33 kPa. The test piece shall be sprayed in the chamber with 5% solution of sodium chloride in water at the standard temperature of $27 \pm 2^\circ \text{C}$ for 50 hours consisting of two periods, each period being of 24 hours of spraying and one hour of draining. The pH of the salt solution shall be such that the collected solution will be in the pH range of 6.5 to 7.2.

L3.3 The unit under test shall not show a corrosion which shows a change of more than 10% variation in the unfavorable direction, in the photometry requirements as specified in the relevant Annexes.

L4.0 Dust Test for Seals & Gaskets

L4.1 A sample unit with any drain hole closed shall be mounted in its normal operating position 150 mm from the wall in a box measuring 900 mm in all directions, containing 5 kg of fine powdered cement.

At intervals of 15 minutes this dust shall be agitated by compressed air or fan blower by projecting blasts of air for a two second period in downward direction into the dust in such a way that the dust shall be completely and uniformly diffused throughout the entire cube. The dust is then allowed to settle.

In the meantime, the lamp is operated at the rated voltage continuously with an operating cycle of 30 minutes (15 min. ON and 15 min. OFF).

This test shall be continued for 5 hrs.

L4.2 After this test, the exterior surface of the unit shall be cleaned and the photometric test repeated and if the maximum intensity is within 10% of the maximum value found in the photometric test, it shall be considered adequately dust tight.

L5.0 Moisture Test for Adequate Drainage

L5.1 A sample unit shall be mounted in its normal operating position with all drain holes open and subjected to a precipitation of 2.5 mm of water per minute delivered at an angle of 45 degrees from a nozzle with a solid cone spray. The rate of water spray shall be measured by the rise of water in small straight sided pan placed horizontally and completely within the area covered by the water spray. During the moisture test, the unit shall revolve about its vertical axis at a rate of 4 rev/min. This test shall be continued for 12 hours. The water be then be turned off and the unit permitted to drain for 1 hour.

L5.2 After the test, unit under test shall not accumulate moisture in excess of 2 ml.

L6.0 Thermal Shock Resistance Test

L6.1 A sample unit shall be connected for not less than 15 minutes with the filament at 7, 14 and 28 V for rated voltages of 6, 12 and 24 V respectively in its normal operating position in an ambient temperature of approximately 27°C .

It shall then be disconnected and immediately plunged into water at 5°C below the ambient such that the lens comes in contact with water.

L6.2 After the test, no cracking or fracture of the lens shall occur.

L7.0 Warpage Test for Devices with Plastic Lenses

L7.1 The sample unit shall be mounted in its normal position and operated as indicated in Table L1 at design working voltage in an oven controlled at $50^{\circ} \pm 10^{\circ}\text{C}$ for a duration of 1 hour

Table : L1

Name of the device	Steady burn	5 Minutes ON 5 Minutes OFF	Steady Flash
Stop Lamp, Reversing Lamp		√	√
Direction Indicator			
All other lighting and light-signalling devices	√		

L7.2 There shall be no evidence of excessive warpage of lenses, which would affect the proper functioning of the unit.

L8.0 Resistance to Oil -Test for Light-Signalling Devices with Plastic Lenses

L8.1 The outer surface of the lens of the sample unit shall be gently wiped with a cotton cloth soaked in detergent lubricating oil. After 5 minutes the surface shall be cleaned by washing in detergent solution. The surface shall be inspected. The application of various oils shall be done on the same sample one after another.

L8.2 The unit under test shall not show any deterioration of the unit.

L9.0 Resistance to Fuel - Test for Light-Signalling Devices with Plastic Lenses

L9.1 The outer surface of the lens of the sample unit shall be gently wiped with a cotton cloth soaked in a mixture of petrol and benzol (90 : 10).

L9.2 After 5 minutes, the surface shall not show any visible change.

Note: Tests prescribed in L8.0 and L9.0 shall be conducted on the same sample, not necessarily in the same sequence.

L10.0 High Voltage (flash) Test

L10.1 The test piece shall be isolated from the condensers, if any, and internally ground, and shall be subjected to flash test, with an alternating current of 500 V rms. at any convenient frequency between 40 and 60 Hz between the end of the terminals and the ground. During this test the lamps shall be removed.

L10.2 The test specimen shall satisfactorily withstand this test without arcing or puncture

ANNEX : M
(See para 5.12)

**SPECIAL REQUIREMENTS FOR NON-REPLACEABLE LIGHT
SOURCES AND LIGHT SOURCE MODULES**

1	Definitions:
1.1	Non-replaceable light source means a light source which can only be replaced by replacement of the device to which this light source is fixed.
1.2	Light source module means an optical part of a device which is specific to that device, is containing one or more non-replaceable light sources, and is only removable from its device with the use of tool(s)
1.3	Light-emitting diode (LED) means a light source where the element for visible radiation is one or more solid state junctions producing injection-luminescence / fluorescence.
2.0	Marking
2.1	In the case of devices with non-replaceable light sources bear the marking of the rated voltage and rated wattage
2.2	in the case of devices with light source module(s), the light source module(s) shall bear
2.2.1	the trade name or mark of the applicant; this marking shall be clearly legible and indelible;
2.2.2	the specific identification code of the module; this marking must be clearly legible and indelible.
2.2.3	the marking of the rated voltage and rated wattage
	the specific identification code of the module; this marking must be clearly legible and indelible. This specific identification code shall comprise the starting letters "MD" for "MODULE". This specific identification code shall be shown in the drawings submitted.
3.0	Requirements:
3.1	The design of the light source module(s) shall be such that even in darkness the light source module(s) can be fitted in no position, but the correct one.
4.0	Life testing:
4.1	The procedure for testing of life for light source modules shall be same as those prescribed AIS 034 as applicable, taking the following into account.
4.2	The number of samples to be subjected to life test (LTQ) shall be 5.
4.3	The life requirement shall be Lsp shall be 2000hours and LTQ shall be 1700 hours.
4.4	The life test shall be carried out on the light source module independently without the lighting/light-signalling device.
4.5	Lumen maintenance shall be established by measuring the illumination of the light/light-signalling device by installing the test piece of the light source module. In the case of light source modules using filament light sources with halogen, the lumen maintenance shall be checked at $75 \pm 5\%$ of LSP and for all other cases at $50 \pm 5\%$ of LSP.
4.6	Test voltage shall be same that specified by the manufacturer and used for checking the illumination of the light/light-signalling device.

FIGURE: A1
 (See para A2.1.2)
STANDARD EUROPEAN BEAM

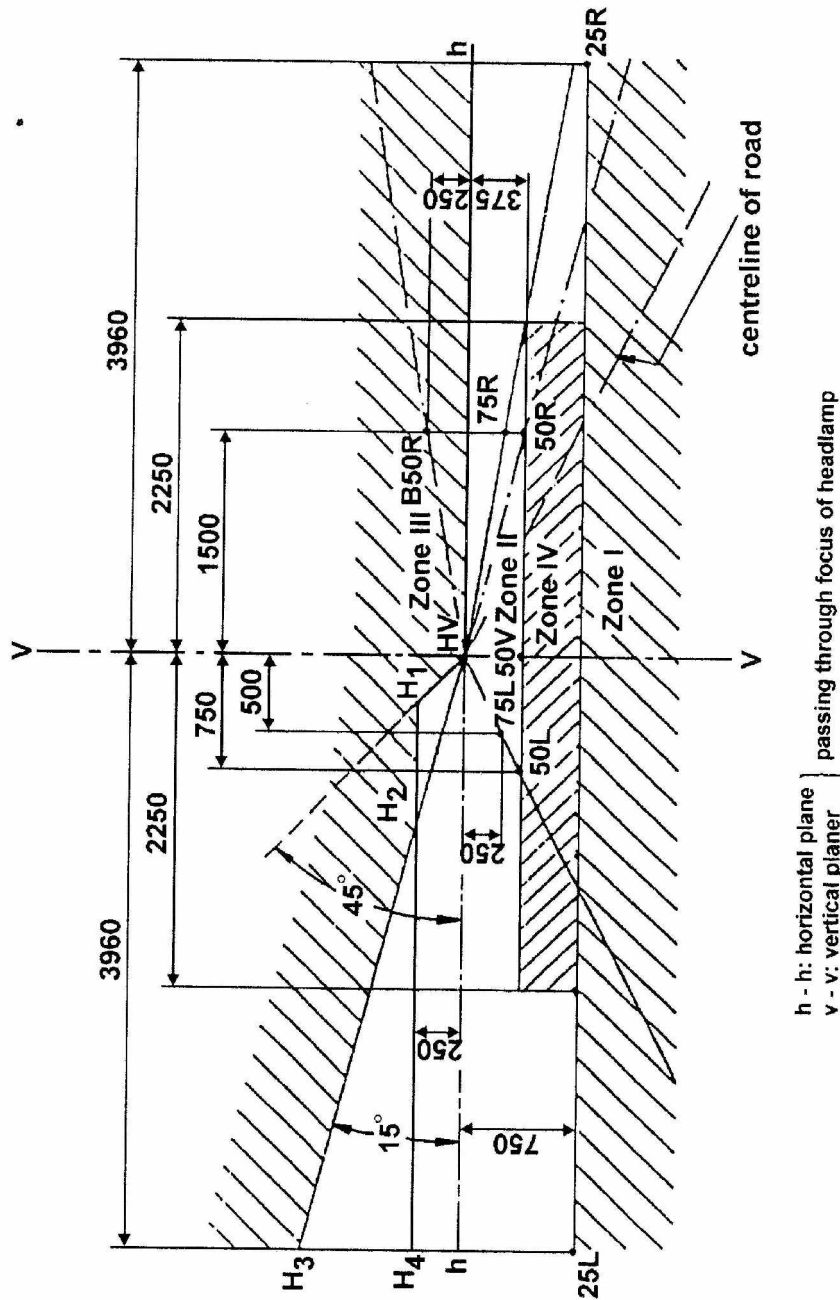

h - h: horizontal plane } passing through focus of headlamp
 v - v: vertical planer }

(Dimensions in mm with screen at 25 m distance)

FIGURE : A2
(See para A2.2.7)

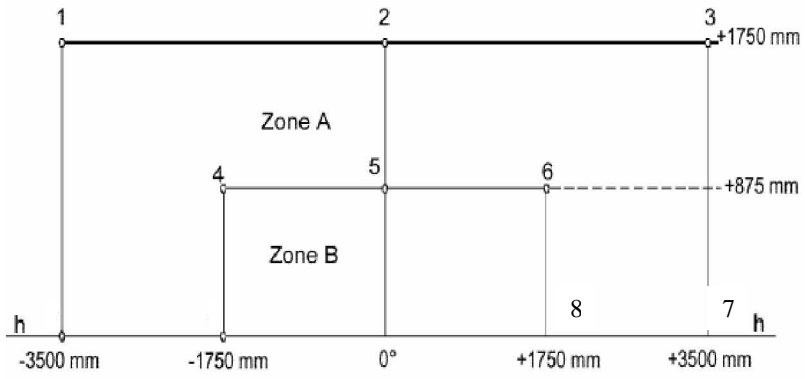

FIGURE: A3
(See para A7.2.1.1)

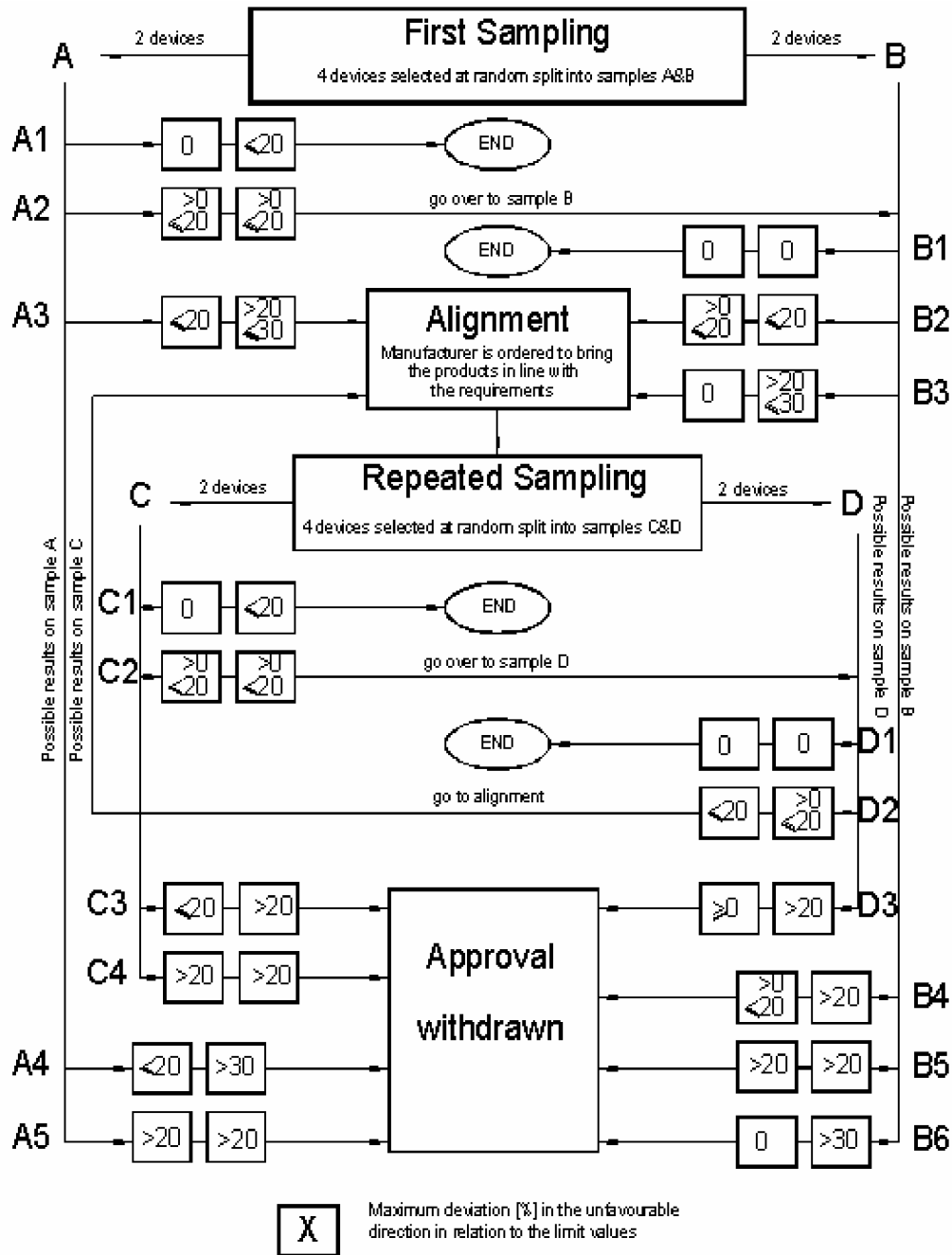
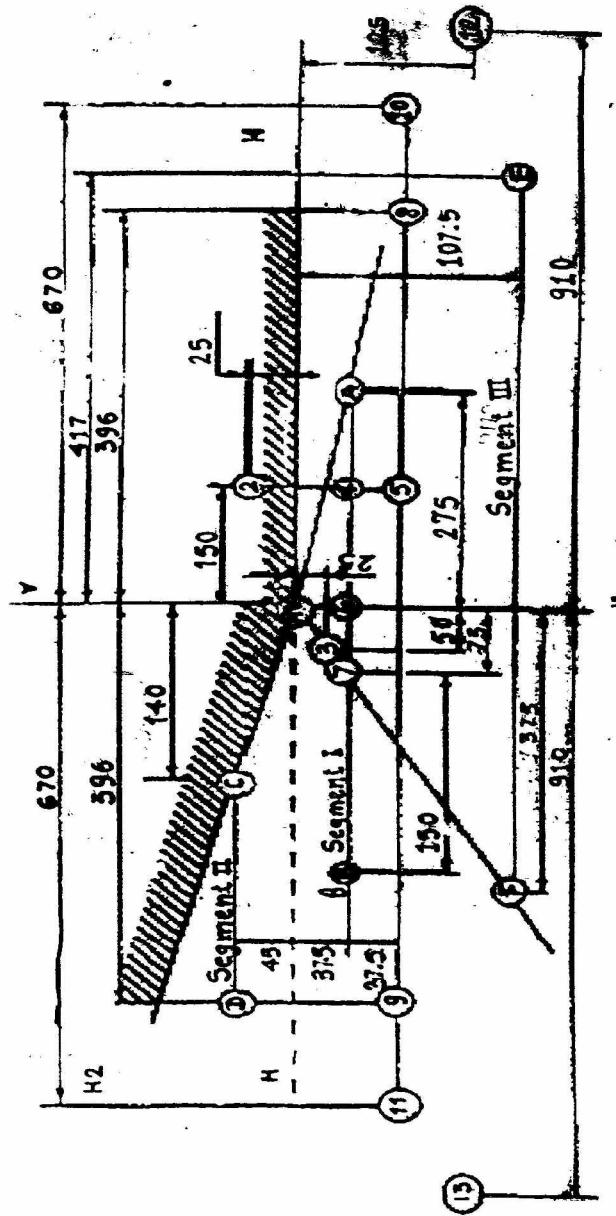

FIGURE : B1
 (See para B2.1.2)
Dipped-Beam- Measuring Screen 1



Do not scale

Dimensions are in cm on a flat vertical screen at 25 m. The HH and VV lines are the intersections with this screen of the horizontal and vertical planes passing through the axis of reference of the dipped beam as declared by the applicant

FIGURE : B2
 (See para B2.1.2)
Dipped-Beam- Measuring Screen 2

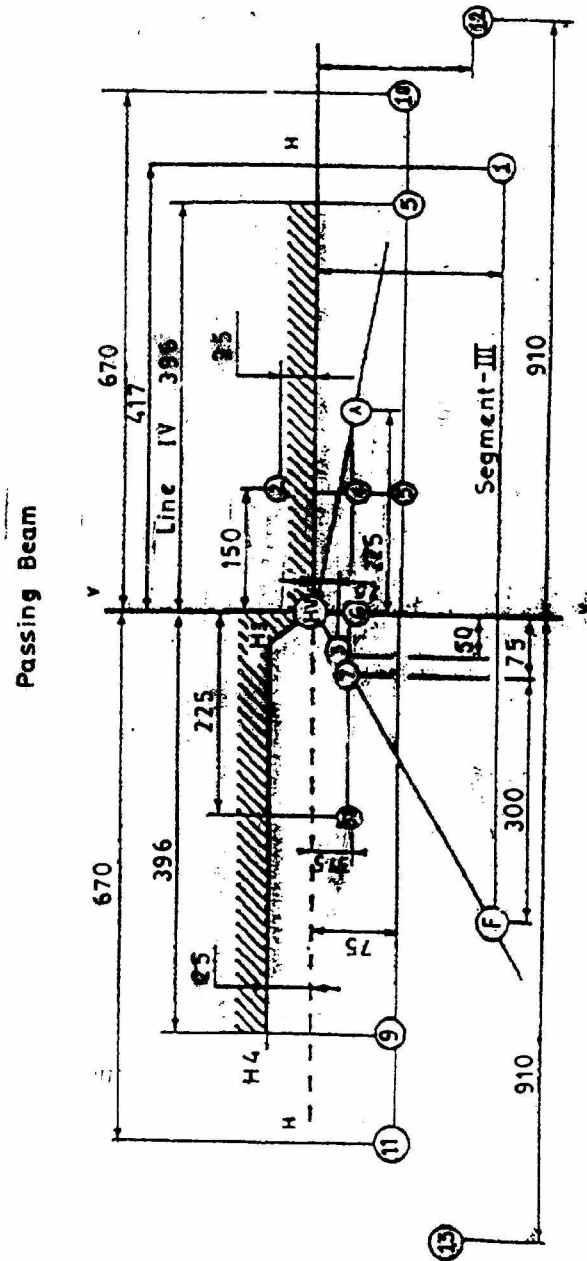

Do not scale

Dimensions are in cm on a flat vertical screen at 25 m. The HH and VV lines are the intersections with this screen of the horizontal and vertical planes passing through the axis of reference of the dipped beam as declared by the applicant

FIGURE: B3
(See para B2.2.6)

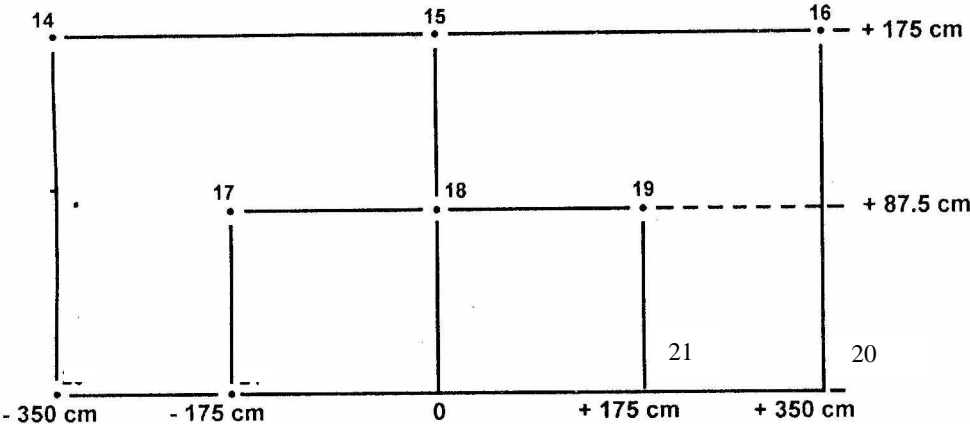

Annex : N
(See Introduction)

COMMITTEE COMPOSITION

Automotive Industry Standards Committee

Chairman	
Shri B. Bhanot	Director The Automotive Research Association of India, Pune
Members	Representing
Shri Alok Rawat	Ministry of Road Transport & Highways, New Delhi
Shri Sushil Kumar	Department of Heavy Industry, Ministry of Heavy Industries & Public Enterprises, New Delhi
Shri. Chandan Saha	Office of the Development Commissioner Small Scale Industries, Ministry of Small Scale Industries, New Delhi
Shri. L . R. Singh	Bureau of Indian Standards, New Delhi
Shri A. S. Lakra Shri D. P. Saste (Alternate)	Central Institute of Road Transport, Pune
Director	Indian Institute of Petroleum, Dehra Dun
Shri R.C. Sethi Shri N. Karuppaiah (Alternate)	Vehicles Research & Development Establishment, Ahmednagar
Shri Rajat Nandi	Society of Indian Automobile Manufacturers
Shri T.C. Gopalan Shri Ramakant Garg (Alternate)	Tractor Manufacturers Association, New Delhi
Shri K.N.D. Nambudiripad	Automotive Components Manufacturers Association
Shri G. P. Banerji	Automotive Components Manufacturers Association

Member Secretary

Mrs. Rashmi Urdhwaresh
Sr. Assistant Director

The Automotive Research Association of India, Pune