

**AIS - 002/2001**

**AUTOMOTIVE INDUSTRY STANDARD**

**Automotive Vehicles -  
Rear - View Mirrors -  
Installation Requirements**

PRINTED BY:

THE AUTOMOTIVE RESEARCH ASSOCIATION OF INDIA  
P. B. NO. 832. PUNE 411 004

ON BEHALF OF :  
AUTOMOTIVE INDUSTRY STANDARD COMMITTEE

UNDER  
CENTRAL MOTOR VEHICLE RULES - TECHNICAL STANDING COMMITTEE

SET-UP BY  
MINISTRY OF ROAD TRANSPORT & HIGHWAYS  
GOVERNMENT OF INDIA

June 2001

Status chart of the Standard to be used by the purchaser  
for updating the record

Sr. No.	Corr- igenda.	Amend- ment	Revision	Date	Remark	Misc.

**General remarks :**

## Introduction

The Government of India felt the need for a permanent agency to expedite the publication of standards and development of test facilities in parallel when the work on the preparation of the standards is going on, as the development of improved safety critical parts can be undertaken only after the publication of the standard and commissioning of test facilities. To this end, the Ministry of Surface Transport (MOST) has constituted a permanent Automotive Industry Standard Committee (AISC) vide order No.RT-11028/11/97-MVL dated September 15, 1997. The standards prepared by AISC will be approved by the permanent CMVR Technical Standing Committee (CTSC). After approval, the Automotive Research Association of India, (ARAI), Pune, being the secretariat of the AIS Committee, has published this standard. For better dissemination of this information ARAI may publish this document on their Web site.

Rear view mirrors and the field of vision provided by them is a safety requirement. This standard prescribes the field of vision to be provided by the rearview mirrors for various categories of vehicles.

Considerable assistance has been taken from the following EEC directives and ECE Regulations in preparing this standard.

1. ECE 46 Uniform provisions concerning the approval of rear view mirrors of motor vehicles with regard to the installation of rear view mirrors.
2. ECE R 81 Uniform provisions concerning the approval of rear view mirrors of two wheeled power driven vehicles, with or without side car, with regard to the mounting of rear view mirrors on handle bars.
3. EEC directive 71/127/EEC as amended by Directive 79/795/EEC, 85/205/EEC, 86/562/EEC, 87/354/EEC and 88/321/EEC.
4. EEC directive 97/24/EC, Chapter 4.

The Committee responsible for preparation of this standard is given in Annex 4.

## **Automotive Vehicles - Rear View Mirrors - Installation Requirements**

### **1. SCOPE**

This standard specifies installation requirements of interior and exterior rear view mirrors in Automotive vehicles.

### **2. REFERENCES**

2.1 Following Indian standards are necessary adjuncts to this standard :

- (1) IS 11825-1986 : Method of weighment of automotive vehicles.
- (2) IS 9727 -1981 : Terms and definitions of dimensions for Mopeds.
- (3) IS 9211 -1979 Denominations and definitions of weights of road vehicles.
- (4) IS 11422-1985 : Terms and definitions of weights of Scooters and Motorcycles.
- (5) IS 14413-1996 : Automotive vehicles – Tell tales symbols and controls on Two-wheeled and Three-wheeled vehicles.
- (6) IS 14272 (Part 1)- 1995 : Automotive vehicles – Types – Terminology –part 1 - three and four-wheelers.

2.2 The definitions given in AIS 001 shall apply.

2.2.1 “Type of vehicle in respect of rear view mirrors” means motor vehicles do not differ among themselves in respect of the specifications given in Annex I.

### **3. TYPE APPROVAL**

3.1 Application for Type Approval

3.1.1 The vehicle manufacturer shall submit following information for type approval of a vehicle:

Technical specifications of vehicle and mirror which shall include at least the details given in Annex 1.

3.2 Modifications/changes in technical specification.

3.2.1 Every functional modification in technical specifications pertaining to installation of rear view mirror declared in accordance with 3.1, shall be intimated to the testing agency. Testing agency may then consider, whether;

3.2.1.1 Vehicle with modifications complies with specified requirements, or,

3.2.1.2 any testing is required.

- 3.2.2 For considering whether testing is required or not, guidelines given in Annex 2 shall be followed.
- 3.2.3 In case of 3.2.1.2, checks for those parameters which are affected by the modifications only need to be carried out.
- 3.2.4 In the event of 3.2.1.1. or in the case of 3.2.1.2 after successful compliance to requirements, the certificate of compliance shall be validated for the modified version.
- 3.2.5 These conditions are applicable irrespective of any change in commercial name of the model.

#### **4. GENERAL REQUIREMENTS**

- 4.1 Rear-view mirrors shall be complying with the requirements of AIS No 001 from the date notified and shall be fitted in such a way that the mirror does not move significantly to change the field of vision as measured or vibrate to an extent which would cause the driver to misinterpret the nature of the image perceived.
- 4.2 The adjusted position of mirror shall remain substantially unchanged after vehicle is driven at speeds of up to 80% of its maximum design speed, but not exceeding 150 km/h, for about 10 minutes time, on test track or highways.
- 4.3 If the interior rear view mirror does not provide any rearward vision, its presence is not mandatory. However, such a fitment is allowed even if it gives partial rearward vision, provided all other vision requirements are met.
- 4.4 In case of 2 wheelers with engine capacity upto 70cc, one mirror on right side and for other 2 wheelers and unbodied 3 wheelers, two mirrors, one on right side and another on left side, shall be fitted or set in such a way that the center of the reflecting surface is at least 280 mm towards the outside of the longitudinal median plane of the vehicle. Before the measurement, the handlebars must remain in the position corresponding to the vehicle's traveling in a straight line and the rear view mirror(s) shall be set in their normal position of use. In case of 2 wheelers with engine capacity not exceeding 70cc, additional mirror on left side may be optionally fitted.
- 4.5 In the case of mirrors fitted on 2 and 3 wheelers (Class VI), mirrors shall comply with the dimensional requirements of clause 6.5 of AIS 001.

## 5. FIELD OF VISION REQUIREMENTS

### 5.1 Vehicle Completely built by the vehicle manufacturer:

In case of completely built vehicles and in the case of incompletely built vehicles (Drive away Chassis), where the rear view mirror is a part of the fitment by the vehicle manufacturer, the field of vision requirements for vehicles with body as mentioned below shall be fulfilled by fitment of suitable class and number of rear view mirrors.

Class of vehicle	Field of vision requirements	
	Mandatory	Additional Options
N <sub>1</sub> with GVW not exceeding 2t & M <sub>1</sub>	(F2 + F1) or (F2 + F3)	F3 or F1
N <sub>1</sub> with GVW > 2t	(F2 + F1) or (F2 + F4)	F3 or F1
M <sub>2</sub>	(F2 + F4)	F5 and (F6 or F7*)
N <sub>2</sub> with GVW not exceeding 7.5t	(F2 + F4) or F5 (F5 is mandatory if F4 is not achieved by convex mirrors)	F1 and (F6 or F7*)
N <sub>2</sub> with GVW > 7.5t	(F2 + F4 + F5)	F1 and (F6 or F7*)
M <sub>3</sub>	(F2 + F4)	F5 and (F6 or F7*)
N <sub>3</sub>	(F2 + F4 + F5) and (F6 or F7*)	F1
3WH with body	(F2 + F3)	F1
* Provided the height of lowermost point of mirror or its support is greater than 2m.		

### 5.2 Incomplete vehicles (Drive-away Chassis):

#### 5.2.1 In case of incompletely built vehicles (Drive away Chassis), where the rear view mirror is not a part of the fitment by the vehicle manufacturer, the sizes of mirror shall be as follows:

Category vehicles	Mirror Size
M2 , N2	130 mm W X 240 mm H
M3, N3	Upper size 183 mm W X 315 mm H Lower Size 183 mm W X 122 mm H The lower mirror would have a wider angle vision than the upper mirror
3 Wheelers	Equivalent to circle of 110 mm diameter.

#### 5.2.2 In such cases, verification would not have been carried out at the time of type approval, as the fitment of mirror would be fitted only at the time of bodybuilding. This shall be indicated in the certificate and is to be verified by the registering authority.

## 6. POSITION

- 6.1 Rear view mirrors shall be so placed that the driver, when sitting on the driving seat, in a normal driving position, has a clear view of the road to the rear and side(s) of the vehicle.
- 6.2 Exterior rear-view mirrors shall be visible through side windows or through the portion of the windscreen that is swept by the windscreen wiper, nevertheless, for design reasons visibility through wiped area shall not apply to exterior rear-view mirrors fitted on left side of vehicles of categories  $M_2$  and  $M_3$  and visible
- 6.3 In the case of any vehicle which is in chassis/cab form when the field of vision is measured, the minimum and maximum body widths shall be stated by the manufacturer and, if necessary, simulated by dummy headboards. All vehicles and mirror configurations taken into consideration during the tests shall be shown on the test report.
- 6.4 The prescribed exterior rear-view mirror on the driver's side of the vehicles shall be so located that an angle of not more than  $55^\circ$  is formed between the vertical longitudinal median plane of the vehicle and the vertical plane passing through the center of rear-view mirror and through the center of the straight line 65mm long which joins the driver's two ocular points (See figure a). This condition shall be deemed to have met if the vehicle manufacturer certifies so.

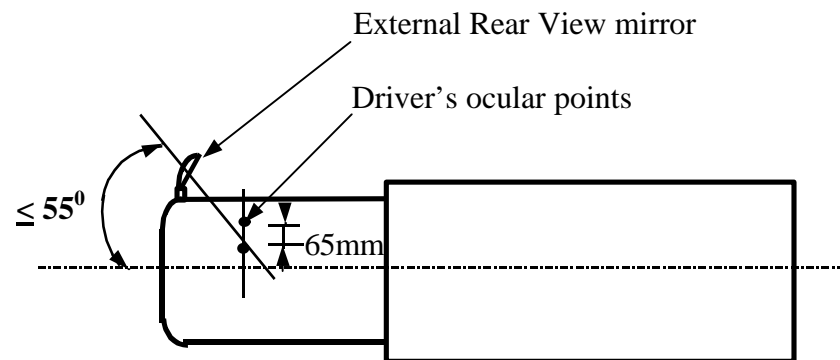

Figure a

- 6.5 Rear-view mirrors shall not project beyond the exterior bodywork of the vehicle substantially more than necessary to comply with the field of vision requirements.
- 6.6 Where the lower edge of an exterior rear-view mirror is less than 2 m above the ground when the vehicle is loaded to its maximum permissible weight (GVW), this rear-view mirror shall not project more than 0.20 m beyond the overall width of the vehicles measured without rear-view mirrors.

- 6.7 In case of vehicle satisfying field of view requirement of F6 or F7, rear view mirrors shall be mounted on vehicles in such a way that, regardless of their position after adjustment, no part of these mirrors or their holders is less than 2 m from the ground when the vehicle is under a load corresponding to its maximum permissible weight (GVW).

These rear-view mirrors shall not, however, be mounted on vehicles, the cab height of which, is such as to prevent compliance with this requirement.

- 6.8 Subject to the requirements of items 6.5, 6.6 and 6.7 rear-view mirrors may project beyond the permissible maximum width of vehicle.

## **7. ADJUSTMENT**

- 7.1 The interior rear-view mirror shall be capable of being adjusted by the driver from his driving position.
- 7.2 The exterior rear-view mirror situated on the driver's side shall be capable of being adjusted from inside the vehicle while the door is closed although the window may be open. The mirror may, however, be locked in position from the outside.
- 7.3 The requirements of item 7.2 do not apply to exterior rear-view mirrors, which, after having been knocked out of alignment, can be returned to their former position without the need of adjustment.

## **8. FIELDS OF VISION**

- 8.1 The fields of vision have been defined in clause 5 of this standard. A tolerance of  $\pm 10\%$  shall apply on all dimensions.
- 8.2 The fields of vision defined in clause 5 shall apply in respect of Ambinocular vision, the eyes being at the driver's ocular points. The fields of vision shall be determined when the vehicle is in running order (includes vehicle in kerb weight condition and driver of weight  $75 \pm 5$  kg ). In case of vehicle other than 2 or 3 wheelers, the vehicle shall carry in addition one front seat passenger, the mass of the passenger being  $75 \pm 5$  kg.. The field of vision shall be established through windows which have a total light transmission factor of at least 70% measured perpendicularly to the surface.
- 8.3 In the case of rear-view mirrors consisting of several reflecting surfaces which are either of different curvature or make an angle with each other on the reflecting surfaces, the combinations (see item 6.2.2 of AIS 001) shall provide the field of vision specified for the class of which they belong.



8.4 Obstructions

8.4.1 Interior rear-view mirrors

8.4.1.1 A reduction in the field of vision due to the presence of devices such as head restraints, parts of body work, sun visors, rear window wipers and heating elements etc., is permissible provided that all these devices together do not obscure more than 15% of the specified field of vision.

8.4.1.2 The degree of obstruction is measured with the headrests adjusted to their lowest possible position and with the sun visors folded back.

8.4.2 *Exterior rear-view mirrors*

8.4.2.1 In the fields of vision specified above, obstruction due to the bodywork components, such as door handles, outline marker lights, direction indicators and the extremities of rear bumpers, as well as reflective surface cleaning components etc, shall not be taken into account if they are responsible for a total obstruction of less than 10% of the specified field of vision.

8.5 Test Procedure

The field of vision shall be determined by placing powerful light sources at the ocular points and examining the light reflected on the vertical monitoring screen. Other equivalent methods may be used.

**ANNEX - 1**

Technical specifications to be submitted by vehicle Manufacturer.

1. Name of the vehicle manufacturer :
2. Address of the vehicle manufacturer :
3. Address of plant(s) where  
vehicle is manufactured :
4. Vehicle model :
5. Type of vehicle :
6. Category of vehicle :
7. Class of rear view mirror fitted  
on vehicle :
8. \* Manufacturer of rear view mirror :
9. Sketch showing mounting  
dimensions of rear view  
mirror on vehicle :
10. Maximum & minimum bodywork  
width in respect of which, the rear  
view mirrors are to be used. :
11. General view from the front, the  
rear and the passenger compartment  
showing where the rear view mirrors  
are fitted, as applicable. :

\* Note 1: Copies of test reports/certificates indicating compliance of rear view mirror to AIS 001 shall be enclosed, if they are available with the test agency.

Note 2: In addition to the names of supplier, rear view mirrors mentioned above, the vehicle manufacturers shall inform the test agency that carried out the type approval, the names of new alternate suppliers for the items as and when they are being introduced.

## ANNEX - 2

**PARAMETERS FOR DECIDING THE NECESSARY TESTS FOR  
EXTENSION OF TYPE APPROVAL**

**PREAMBLE:**

This Annex gives factors to be considered while selecting a vehicle to represent a range of variants for establishing compliance for Type Approval. This is also applicable to:

- Extension of Type Approval for changes in Technical Specifications of an already Type Approved Model.
- Establishing compliance of new models /variants based on an already Type Approved Model.

In general, when changes in Technical Specifications of a mirror do not affect the performance adversely, and are still within the stipulated limits, the Type Approval can be extended without further testing. If the changes affect some of the performance parameters, tests shall be carried out only for those parameters.

Where some parts, components / assemblies, used on an already Type Approved model are used in another model / variant, no additional tests will be needed to establish compliance of these parts, components / assemblies to the respective performance requirements.

In the case of following changes, tests shown against each, are necessary to be carried out for establishing compliance.

Sr. No.	PARAMETER AND CHANGE	TEST TO BE CONDUCTED
1.	Change in Class of Mirror.	All tests/checks.
2.	Change in mounting support which changes the orientation in vehicle.	Field of vision
3.	Change in width of vehicle	If the width is increased and the increase is within the permitted obstruction of view limits, no test is required.
4.	Any change in drivers ocular point	All tests/checks.
5.	Same vehicle model but change in vehicle category and variant.	Field of vision

Changes other than those listed above are considered to be having no adverse effect on Rear View Mirror installation requirements on vehicle.

ANNEX – 3  
FIGURES

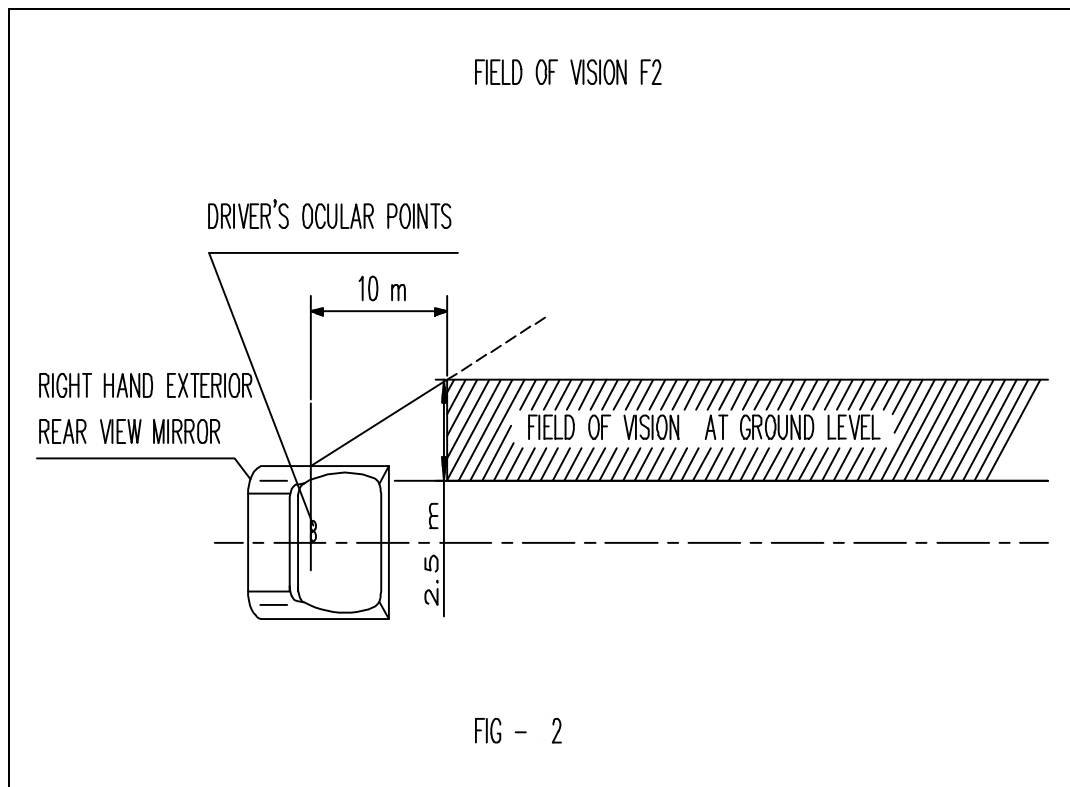
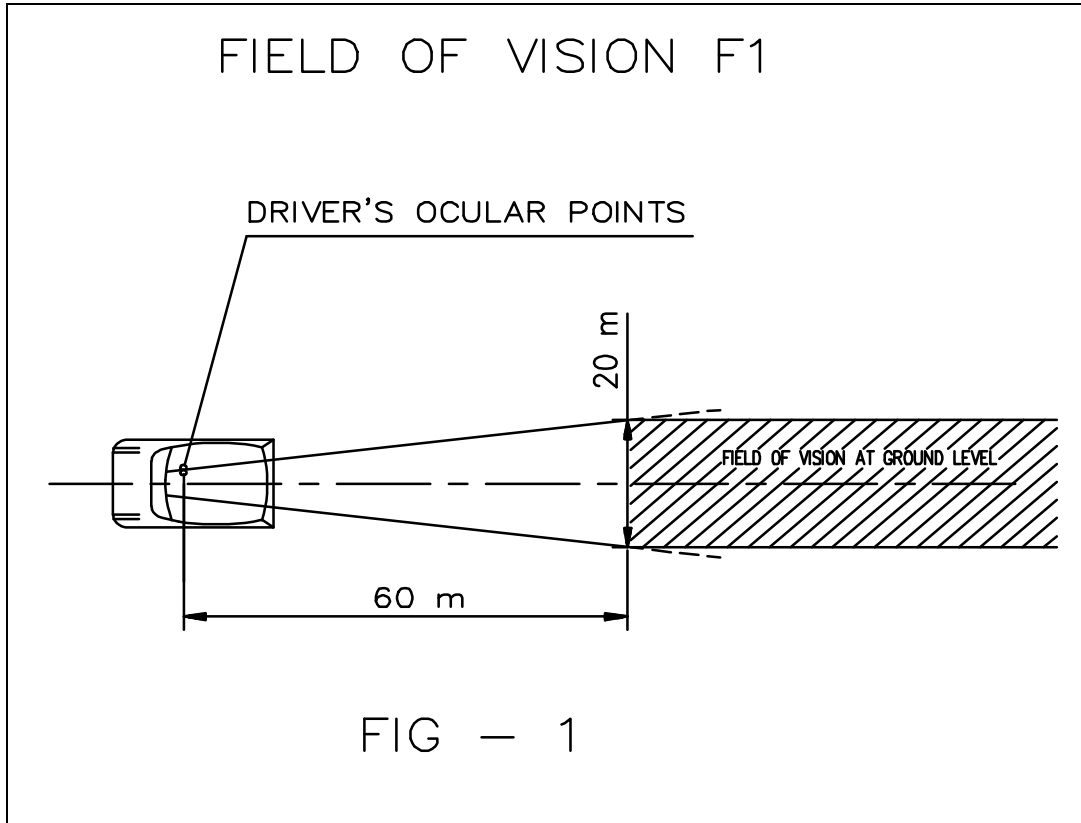

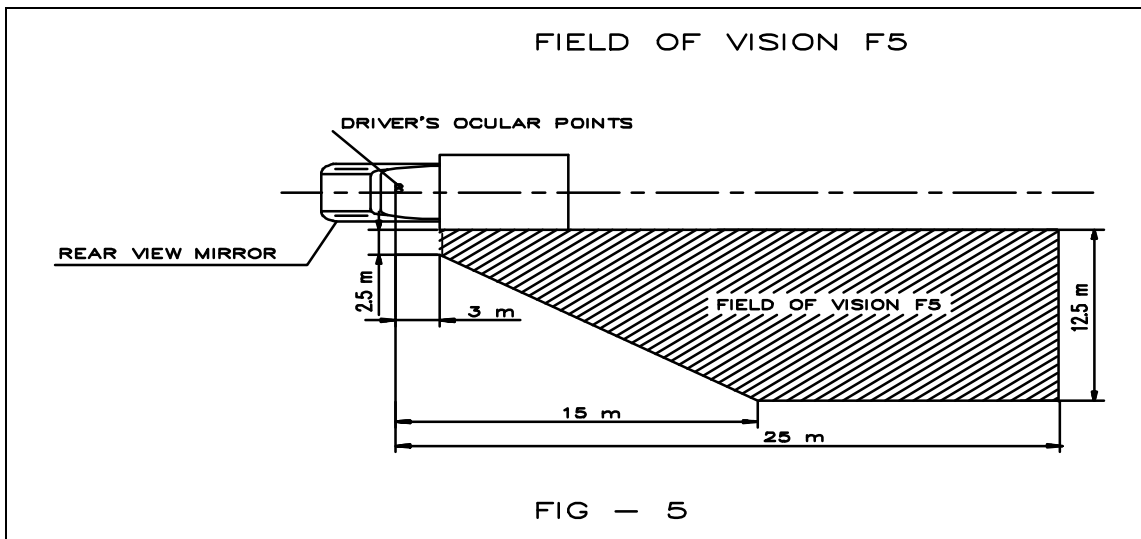
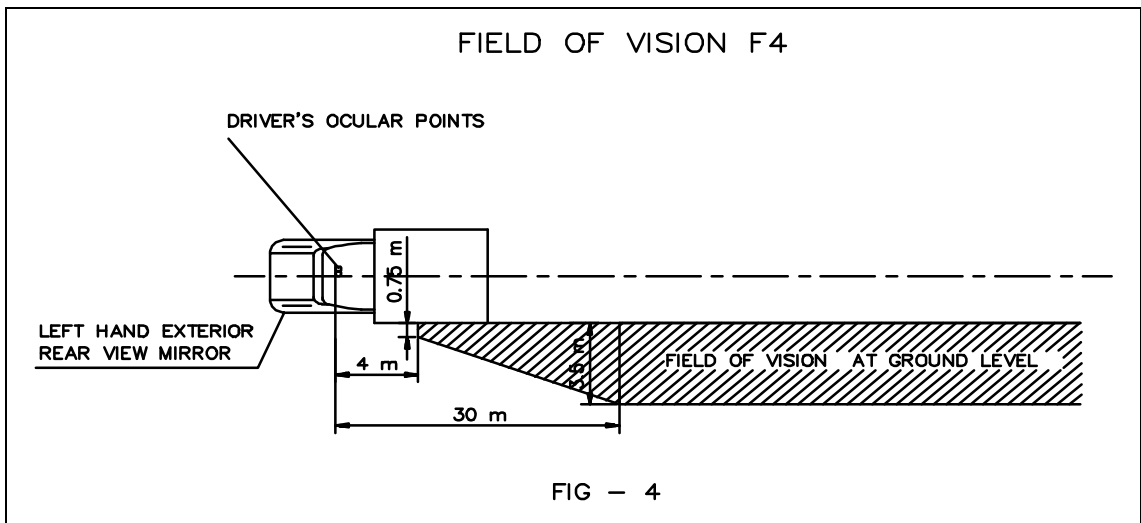
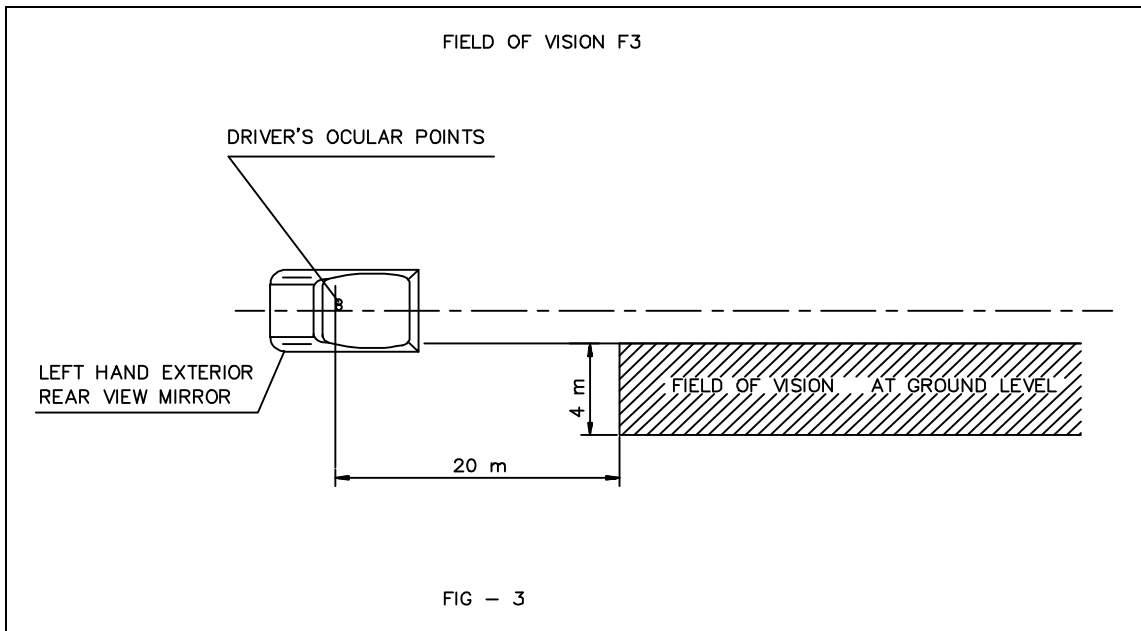

### FIELD OF VISION F6

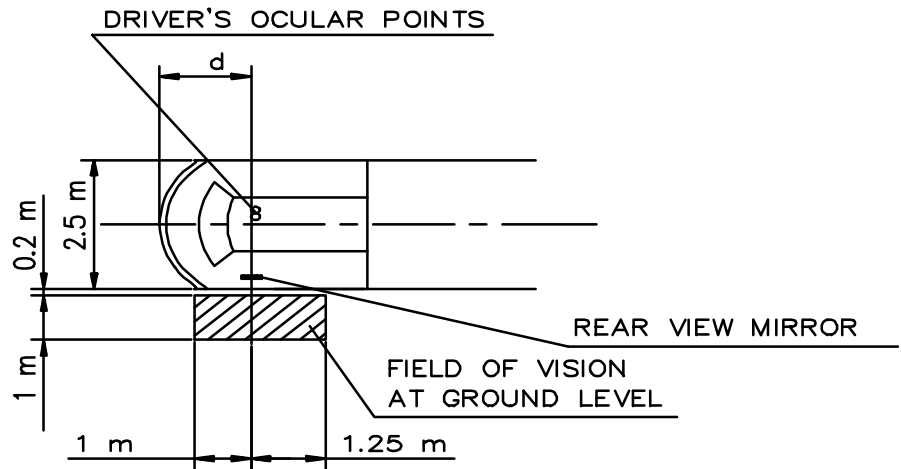

FOR  $d > 1 \text{ m}$

FIG. 6

### FIELD OF VISION F7

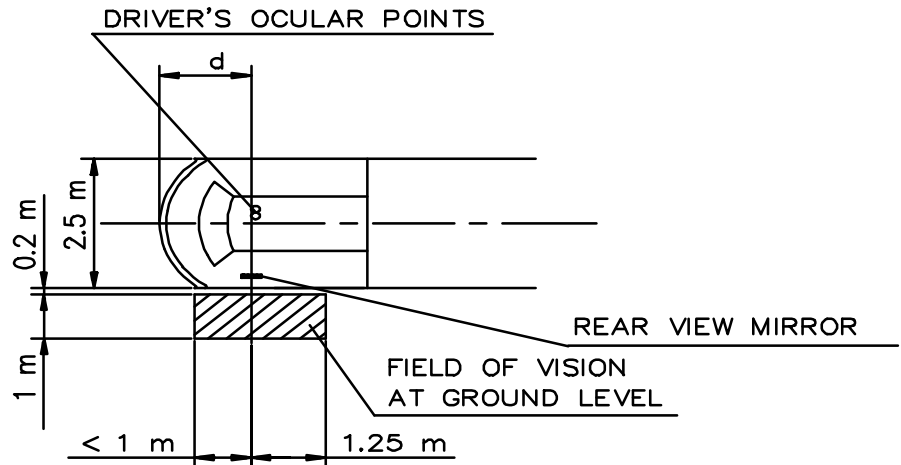

FOR  $d \leq 1 \text{ m}$

FIG. 7

'd' IS HORIZONTAL DISTANCE BETWEEN THE VERTICAL PLANE PASSING THROUGH DRIVER'S OCULAR POINTS & FRONT EDGE OF BUMPER

**ANNEXURE - 4**  
(See Introduction)  
**COMMITTEE COMPOSITION**  
**Automotive Industry Standards Committee**

**Chairman**

Shri. B. Bhanot                      Director  
The Automotive Research Association of India, Pune

**Members**

Shri. Alok Rawat                      Ministry of Road Transport & Highways, New Delhi

Shri. V.C. Mathur                      Department of Heavy Industry,  
Ministry of Industries & Public Enterprises, New Delhi

Shri. G. S. Kashyab                      Office of the Development Commissioner  
Shri. M.K. Bhat (Alternate )              Small Scale Industries,  
Ministry of Industry, New Delhi.

Shri. A. R. Gulati                      Bureau of Indian Standards, N. Delhi.

Shri. R. C. Sethi                      Vehicle Research & Development Establishment,  
Shri. N. Karuppaiah ( Alternate )              Ahmednagar.

Shri. D. G. Shirke                      Central Institute of Road Transport, Pune  
Shri. P. C. Barjatia ( Alternate )

Shri. R. M. Shrivastava                      Society of Indian Automobile Manufacturers.

Shri. T. M. Balaraman                      Society of Indian Automobile Manufacturers.

Shri. I. V. Rao                      Society of Indian Automobile Manufacturers.

Shri. Z. A. Mujawar ( Alternate )              Society of Indian Automobile Manufacturers.

Shri. Vivek Adyanthaya                      Society of Indian Automobile Manufacturers.  
(Alternate )

Shri. U. K. Kini ( Alternate )              Society of Indian Automobile Manufacturers.

Shri. T. C. Gopalan                      Tractor Manufacturers Association, New Delhi.

Shri. Vishnu Mathur                      Automotive Components Manufacturers Association.

Shri.K. N. D. Nambudiripad                      Automotive Components Manufacturers Association

**Member Secretary**

**Mrs. Rashmi Urdhwareshe**

Sr. Assistant Director,

The Automotive Research Association of India, Pune