

इंटरनेट

मानक

Disclosure to Promote the Right To Information

Whereas the Parliament of India has set out to provide a practical regime of right to information for citizens to secure access to information under the control of public authorities, in order to promote transparency and accountability in the working of every public authority, and whereas the attached publication of the Bureau of Indian Standards is of particular interest to the public, particularly disadvantaged communities and those engaged in the pursuit of education and knowledge, the attached public safety standard is made available to promote the timely dissemination of this information in an accurate manner to the public.

“जानने का अधिकार, जीने का अधिकार”

Mazdoor Kisan Shakti Sangathan

“The Right to Information, The Right to Live”

“पुराने को छोड़ नये के तरफ”

Jawaharlal Nehru

“Step Out From the Old to the New”

IS 695 (1986): acetic acid [PCD 9: Organic Chemicals
Alcohols and Allied Products and Dye Intermediates]



“ज्ञान से एक नये भारत का निर्माण”

Satyanarayan Gangaram Pitroda

“Invent a New India Using Knowledge”



“ज्ञान एक ऐसा खजाना है जो कभी चुराया नहीं जा सकता है”

Bhartrhari—Nitiśatakam

“Knowledge is such a treasure which cannot be stolen”

BLANK PAGE



IS : 695 - 1986

Indian Standard

Reaffirmed 1996

SPECIFICATION FOR ACETIC ACID

(Third Revision)

Second Reprint SEPTEMBER 1995

UDC 661.731

© Copyright 1987

BUREAU OF INDIAN STANDARDS
MANAK BHAVAN, 9 BAHADUR SHAH ZAFAR MARG
NEW DELHI 110002

Gr 6

February 1987

Indian Standard

SPECIFICATION FOR ACETIC ACID

(*Third Revision*)

Alcohol and Allied Products Sectional Committee, PCDC 10

Chairman

DR R. B. ROY CHOUDHRY

Vice-Chairman

DR B. N. MATTOO

Representing

Union Carbide India Ltd, Calcutta

Forensic Science Laboratory; and Chemical
Analyser to the Government of Maharashtra,
Bombay

Members

SHRI K. C. SAH (*Alternate I to*

Dr R. B. Roy Choudhry)

SHRI V. R. DUBBY (*Alternate II to*

Dr R. B. Roy Choudhry)

DR S. K. MEGHAL (*Alternate to*

Dr B. N. Mattoo)

SHRI K. D. AMRE

National Organic Chemical Industries Ltd,
Bombay

SHRI P. CHAWLA (*Alternate*)

SHRI WILSON D. ANDRAT

Polychem Ltd, Bombay

DR R. C. DIKSHIT (*Alternate*)

SHRI J. A. ASHTAPUTRE

Ministry of Defence (DGI)

SHRI P. K. MAZUMDAR (*Alternate*)

SHRI R. A. BAKSHI

Indian Organic Chemical Industries Ltd, Kopoli

SHRI S. H. KILLEDAR (*Alternate*)

SHRI R. A. BAKSHI

Indian Chemical Manufacturers' Association,
Calcutta

SHRI P. R. MAHALINGAM (*Alternate*)

SHRI O. P. BHATIA

All India Distillers' Association, New Delhi

SHRI P. N. SAPRA (*Alternate*)

DR G. S. CHAUDHARI

Directorate of Health Services, Lucknow

CHIEF CHEMIST

Central Revenues Control Laboratory, New Delhi

DEPUTY CHIEF CHEMIST (*Alternate*)

SHRI H. C. CHOPRA

Synthetic & Chemicals Ltd, Bombay

SHRI R. N. MEHROTRA (*Alternate*)

DR D. K. DAS

National Test House, Calcutta

SHRI N. C. GHATTERJEE (*Alternate*)

SHRI R. C. GUPTA

Directorate General of Technical Development,
New Delhi

SHRI S. N. PANDEY (*Alternate*)

(*Continued on page 2*)

© Copyright 1987

BUREAU OF INDIAN STANDARDS

This publication is protected under the *Indian Copyright Act* (XIV of 1957) and reproduction in whole or in part by any means except with written permission of the publisher shall be deemed to be an infringement of copyright under the said Act.

(Continued from page 1)

| <i>Members</i> | <i>Representing</i> |
|---|---|
| SHRI E. K. JAYANARAYANAN | Mohan Meakin Breweries Ltd, Ghaziabad |
| SHRI JITENDRA MOHAN (<i>Alternate</i>) | |
| SHRI S. K. MAHAJAN | Hindustan Polymers Ltd, Bombay |
| SHRI A. K. MUKHERJEE (<i>Alternate</i>) | |
| DR J. RAJARAM | Herdillia Chemicals Ltd, Bombay |
| SHRI V. G. FADNIS (<i>Alternate</i>) | |
| SHRI R. SANTHANAM | Alkali & Chemicals Corporation of India Ltd, Calcutta |
| SHRI S. C. TALAPATRA (<i>Alternate</i>) | |
| SHRI D. R. K. SAYOJI RAO | Sir Silk Ltd, Hyderabad |
| SHRI SREEDHARAN (<i>Alternate</i>) | |
| DR V. N. SEHGAL | Central Forensic Science Laboratory, New Delhi |
| DR V. S. BISARIA (<i>Alternate</i>) | |
| SHRI SURENDRA SINGH | Indian Drugs and Pharmaceuticals Ltd, Muzaffarpur |
| SHRI R. K. BANDOPADHYAYA (<i>Alternate</i>) | |
| DR S. K. SOMAIYA | Somaiya Organics (India) Ltd, Barabanki |
| SHRI H. B. DESAI (<i>Alternate</i>) | |
| DR MOHAMMED SWALEH | Ministry of Chemicals and Fertilizers State Forensic Science Laboratories, Government of Uttar Pradesh, Lucknow |
| SHRI O. P. TANEJA | National Sugar Institute, Kanpur |
| DR L. VISHWANATHAN | Director General, ISI (<i>Ex-officio Member</i>) |
| SHRI M. S. SAXENA, Director (P & C) | |

Secretary

SHRI M. A. U. KHAN
Joint Director (P & C), ISI

Panel for Acids, Esters, Ethers and Ketones, PCDC 10 : P3

Convener

SHRI V. D. JOSEPH Union Carbide India Ltd, Bombay

Members

| | |
|---|--|
| SHRI K. C. SAH (<i>Alternate</i> to Shri V. D. JOSEPH) | |
| SHRI K. D. AMRE | National Organic Chemicals Industries Ltd, Bombay |
| SHRI P. CHAWLA (<i>Alternate</i>) | |
| SHRI V. K. PARAMESWARA AYYAR | Industrial Solvents & Chemicals Pvt Ltd, Bombay |
| SHRI G. B. SHAH (<i>Alternate</i>) | |
| DR S. C. BISARIA | Vam Organic Chemicals Ltd, Gajraula |
| SHRI YOGENDRA KUMAR (<i>Alternate</i>) | |
| SHRI H. B. DESAI | Somaiya Organics (India) Ltd, Barabanki |
| DR R. B. SRIVASTAVA (<i>Alternate</i>) | |
| SHRI R. V. GOKHALE | Herdi lia Chemicals Ltd, Bombay |
| SHRI A. A. INAMDAR | Hico Products Ltd, Bombay |
| SHRI P. S. RAMANATHAN | Indian Drugs & Pharmaceuticals Ltd, Muzaffarpur |
| SHRI V. C. SHUKLA (<i>Alternate</i>) | |
| SHRI T. N. RAWAL | Ministry of Defence (DGI) |
| SHRI P. N. AGARWAL (<i>Alternate</i>) | |

Indian Standard

SPECIFICATION FOR ACETIC ACID

(Third Revision)

0. FOREWORD

0.1 This Indian Standard (Third Revision) was adopted by the Indian Standards Institution on 30 June 1986, after the draft finalized by the Alcohols and Allied Products Sectional Committee had been approved by the Petroleum, Coal and Related Products Division Council.

0.2 Acetic acid is used in the manufacture of cellulose acetate, vinyl acetate and in textile industry for dyeing purposes. It is also used in pharmacy and in the manufacture of rubber balloons, sanitary goods and surgical gloves from rubber latex. Various chemical compounds like acetates of lead, sodium and calcium are produced from acetic acid. Some of the popular thinners, such as butyl and ethyl acetates, used in the paint industry, are also prepared from acetic acid. In a dilute form, popularly known as white-wine vinegar it is used in pickles.

0.3 This standard was first issued in 1955, covering the requirements of three grades of acetic acid, namely, pure, pharmaceutical and technical. With increase in production and on the basis of experience gained in use of the earlier version of this standard, it was considered imperative to upgrade the minimum quality requirements stipulated for different grades of the material and accordingly the standard was revised in 1967. The revised standard covered three grades of acetic acid, namely, technical, pure and analytical reagent. The requirements of the pure grade covered those for pharmaceutical grade acetic acid given in the Indian Pharmacopoeia, second edition. A new sampling scheme and criteria for conformity was also included. This standard was again revised in 1975 in which limits for formic acid and acetaldehyde for AR grade were introduced. Requirement for colour was also modified. In order to meet the present day requirements of acetic acid, this third revision has been undertaken in which requirements for water for AR grade and relative density have been included. The requirements for acetaldehyde for AR grade have also been modified. This third revision is expected to go a long way in assisting the varied and discriminating consumers in getting a material of acceptable quality and the manufacturers in producing material complying with these requirements.

0.4 For the purpose of deciding whether a particular requirement of this standard is complied with the final value, observed or calculated, expressing the result of a test or analysis, shall be rounded off in accordance with IS : 2-1960*. The number of significant places retained in the rounded off value should be the same as that of the specified value in this standard.

1. SCOPE

1.1 This draft standard prescribes the requirements and methods of sampling and test for acetic acid.

2. GRADES

2.1 The material shall be of three grades, namely:

- a) Technical,
- b) Pure, and
- c) Analytical Reagent (AR).

3. REQUIREMENTS

3.1 Description — At all temperatures above the crystallizing point, the material shall be a clear liquid, free from suspended matter and having a characteristic pungent odour.

3.2 Colour

3.2.1 The colour of pure and analytical reagent grades of the material shall not be or more than 20 Hazen units.

3.2.2 The technical grade material shall be colourless or may have a pale yellow/straw colour.

NOTE — The material which has been stored in aluminium or wax lined containers may exhibit slight opalescence or may develop opalescence on dilution with water. Material showing such slight opalescence but otherwise complying with the requirements given in Table 1 shall be deemed to conform to this standard.

3.3 The material shall also comply with the requirements given in Table 1.

3.4 The material, when required for pharmaceutical purposes, shall contain not more than 2 parts per million of arsenic (as As) which is equivalent to 2.664 parts (as As_2O_3) when tested as prescribed in IS : 2088-1983†.

*Rules for rounding off numerical values (revised).

†Methods for determination of arsenic (second revision).

TABLE 1 REQUIREMENTS FOR ACETIC ACID

(Clause 3.3)

| Sl No. | CHARACTERISTIC | REQUIREMENTS FOR GRADE | | | METHOD OF TEST, REF TO |
|--------|---|------------------------|------------------------------|------------------------------|------------------------|
| | | Technical | Pure | Analytical Reagent | |
| (1) | (2) | (3) | (4) | (5) | (6) |
| i) | Solubility in water | — | Shall be completely miscible | No turbidity within one hour | A-1 |
| ii) | Relative density at 27/27°C, <i>Max</i> | 1.052 8 | 1.049 6 | 1.048 3 | 6 of IS : 82-1973* |
| iii) | Acetic acid content (CH ₃ COOH), percent by mass, <i>Min</i> | 98.0 | 99.5 | 99.7 | A-2 |
| iv) | Crystallizing point, °C, <i>Min</i> | — | 15.6 | 16.0 | A-3 |
| v) | Residue on evaporation, percent by mass, <i>Max</i> | 0.02 | 0.01 | 0.001 | A-4 |
| vi) | Chlorides (as Cl), ppm, <i>Max</i> | 35 | 15 | 1 | A-5 |
| vii) | Iron (as Fe), ppm, <i>Max</i> | — | 2 | 1 | A-6 |
| viii) | Sulphates (as SO ₄), ppm, <i>Max</i> | 35 | 15 | 1 | A-7 |
| ix) | Heavy metals [(including iron) calculated as Pb], ppm, <i>Max</i> | 20 | 5 | 2 | A-8 |
| x) | Formic acid (HCOOH), percent by mass, <i>Max</i> | 0.35 | 0.15 | 0.025 | A-9 |
| xi) | Acetaldehyde (CH ₃ CHO), percent by mass, <i>Max</i> | 0.15 | 0.05 | 0.003 | A-10 |
| xii) | Oxidizable impurities | — | To pass the test | To pass the test | A-11 |
| xiii) | Water content, percent by mass, <i>Max</i> | — | — | 0.2 | IS : 2362-1973† |

*Methods of sampling and test for thinners and solvents for paints (*first revision*).

†Determination of water by the Karl Fischer method (*first revision*).

4. PACKING AND MARKING

4.1 Packing — The material shall be packed in suitable containers as agreed to between the purchaser and the supplier, and shall be subject to the provisions of law in force in the country for the time being.

NOTE — Acetic acid expands on freezing and due precautions shall be taken in its packing and storing.

4.2 Marking

4.2.1 Each container shall be securely closed and marked with the following:

- a) Manufacturer's name;
- b) Grade of the material;
- c) Tare, gross and net mass;
- d) Year of manufacture; and
- e) Recognized trade-mark, if any.

4.2.2 Each container shall bear the caution label worded as under:

CORROSIVE ! VAPOUR AND LIQUID DANGEROUS TO EYES !

NOTE 1 — Necessary safeguards against the risk arising from storage and handling of large volumes of corrosive liquids (see IS : 1446-1959*) shall be provided and all due precautions shall be taken [see also IS : 1260 (Part 1)-1973†].

NOTE 2 — Except when they are opened for the purpose of cleaning and rendering them free from acetic acid vapour, all empty tanks or other containers shall be kept securely closed unless they have been cleaned and freed from acetic acid vapour.

4.2.3 The containers may also be marked with the ISI Certification Mark.

NOTE — The use of the ISI Certification Mark is governed by the provisions of the Indian Standards Institution (Certification Marks) Act and the Rules and Regulations made thereunder. The ISI Mark on products covered by an Indian Standard conveys the assurance that they have been produced to comply with the requirements of that standard under a well-defined system of inspection, testing and quality control which is devised and supervised by ISI and operated by the producer. ISI marked products are also continuously checked by ISI for conformity to that standard as a further safeguard. Details of conditions, under which a licence for the use of the ISI Certification Mark may be granted to manufacturers or processors, may be obtained from the Indian Standards Institution.

*Classification of dangerous goods.

†Pictorial markings for handling and labelling of goods: Part 1 Dangerous goods (first revision).

5. SAMPLING

5.1 The method of drawing representative samples of the material shall be as prescribed in Appendix B.

6. TEST METHODS

6.1 Tests shall be conducted according to the methods prescribed in Appendix A. Reference to the relevant clauses of Appendix A is given in col 6 of Table 1.

6.2 **Quality of Reagents** — Unless specified otherwise, pure chemicals and distilled water (*see* IS : 1070-1977*) shall be employed in tests.

NOTE — 'Pure chemicals' shall mean chemicals that do not contain impurities which affect the results of analysis.

APPENDIX A

(Table 1 and Clause 6.1)

METHODS OF TEST FOR ACETIC ACID

A 1. DETERMINATION OF SOLUBILITY IN WATER

A-1.0 Outline of the Method — A known volume of acetic acid is mixed with a known volume of water and observed for turbidity.

A-1.1 Procedure — Dilute 1 volume of acid with 3 volumes of water in a clean test tube. Shake well and allow to stand for 1 hour. Compare with an equal volume of water in a test tube.

A-1.2 The test solution shall be as clear as in the comparator tube.

A-2. DETERMINATION OF ACETIC ACID CONTENT

A.2.0 Outline of the Method — A known amount of the material is titrated against standard sodium hydroxide solution using phenolphthalein as indicator. From the titre values, the percent acetic acid equivalent in the sample is calculated. This is then corrected for the formic acid content to get the percentage of acetic acid in the sample.

A-2.1 Apparatus

A-2.1.1 Lunge-Rey Pipette — of the shape and dimensions as shown in Fig. 1.

*Specification for water for general laboratory use (*second revision*).

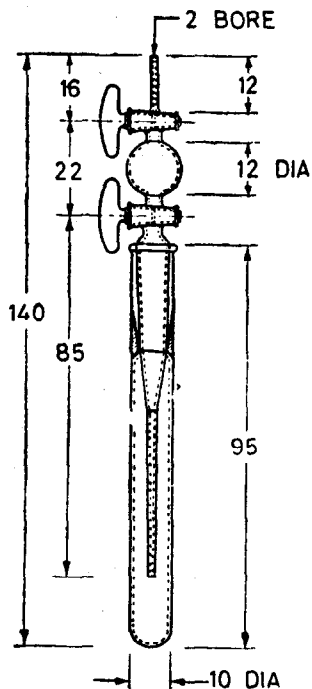

All dimensions in millimetres.

FIG. 1 LUNGE-REY PIPETTE

A-2.1.2 Conical Flask — 250-ml capacity.

A-2.2 Reagents

A-2.2.1 Phenolphthalein Indicator Solution— Dissolve 0.1 g of phenolphthalein in 100 ml of 60 percent ethyl alcohol and add solution of sodium hydroxide (A-2.2.2) until the colour turns faint pink.

A-2.2.2 Standard Sodium Hydroxide Solution — 1 N.

A-2.3 Procedure — Transfer about 2.5 g of the material, accurately weighed by means of the Lunge-Rey pipette, into a conical flask, Add about 50 ml of freshly boiled and cooled water and 0.5 ml of phenolphthalein indicator solution and titrate with sodium hydroxide solution.

A-2.4 Calculation — Find the mass of acetic acid on the basis that 1 ml of normal sodium hydroxide solution is equivalent to 0.060 05 g of acetic acid (CH_3COOH), and deduct the acetic acid equivalent of any formic acid present, as determined under **A-9**.

$$\text{Acetic acid (} \text{CH}_3\text{COOH } \text{), percent} = \frac{6.005 V N}{M} - 1.299 S$$

where

V = volume in ml of the standard sodium hydroxide solution used,

N = normality of standard sodium hydroxide solution,

S = percentage of formic acid as determined in **A-9**, and

M = mass in g of the material taken for the test.

A-3. DETERMINATION OF CRYSTALLIZING POINT

A-3.1 Apparatus

A-3.1.1 Test-Tube — about 25 mm in diameter and 150 mm in length (see IS : 2618-1963*).

A-3.1.2 Thermometer — graduated for partial immersion to a depth of 100 mm and possessing the following characteristics:

- | | |
|---|---------------------|
| a) Range | −0.5 to + 40.5°C |
| b) Graduations | 0.1°C |
| c) Overall length | About 400 mm |
| d) Length of main scale, <i>Min</i> | 280 mm |
| e) Bulb length | 10 to 15 mm |
| f) Stem diameter | 5.5 to 7.0 mm |
| g) Distance from bottom of bulb to main scale | Not less than 30 mm |
| h) Maximum error | 0.4°C |
| j) Maximum error in an interval | 0.4/5°C |

A-3.1.2.1 Any other thermometer of similar range and accuracy may also be used.

A-3.1.2.2 The thermometer shall bear certificate from the National Physical Laboratory, New Delhi, or any other institution authorized by the Government of India to issue such a certificate.

*Specification for test-tubes.

A-3.2 Procedure — Fill the dried test-tube with the material to a depth of about 100 mm and insert the thermometer. Place the test-tube in water at 10 to 11°C so that the portion occupied by the material is completely immersed. Allow the material to cool, without stirring, until the thermometer indicates about 2 deg below the expected crystallizing point. Lift the tube out of water and stir rapidly with the thermometer to induce the formation of minute crystals. At the moment the crystallization begins, the temperature will rise rapidly and then remain constant for a few moments. As soon as the steady temperature is approached, stop stirring and suspend the thermometer so that its bulb is centrally disposed in the crystallizing mass. Record the temperature at which the thermometer remains constant as the crystallizing point.

A-3.2.1 If after cooling and stirring as described under A-3.2, the temperature rise exceeds 3 deg, the observed crystallizing point is liable to be below the true figure. In such cases, repeat the operation with less super-cooling.

A-3.2.2 If crystallization does not begin after removal of the test-tube from the cold water and vigorous stirring, withdraw the thermometer and touch against some solid acetic acid previously prepared and then quickly re-insert it in the material under test and resume stirring.

A-3.2.3 Precautions shall be taken to prevent contamination of the sample with moisture during the test.

A-4. DETERMINATION OF RESIDUE ON EVAPORATION

A-4.0 Outline of the Method — A known amount of the material is evaporated to dryness, the residue cooled and weighed.

A-4.1 Procedure — Accurately weigh about 100 g of the material in a tared silica basin. Gently evaporate it to dryness on a water bath. Dry the residue for one hour in an oven at $120 \pm 2^\circ\text{C}$ and cool in a desiccator and weigh again. Retain the residue for further tests.

A-4.2 Calculation — Difference in mass of the silica basin gives the mass of the residue on evaporation. Express the mass of the residue as percentage of the mass of the material taken for the test.

A-5. TEST FOR CHLORIDES

A-5.0 Outline of the Method — A solution of the material of known concentration is treated with silver nitrate solution in presence of dilute nitric acid. The opalescence produced is compared with the opalescence in a standard solution treated similarly with equal amounts of the reagents.

A-5.1 Apparatus

A-5.1.1 *Volumetric Flask* — 250-ml capacity.

A-5.1.2 *Nessler Cylinders* — 100-ml capacity (*see* IS : 4161-1967*).

A-5.2 Reagents

A-5.2.1 *Dilute Nitric Acid* — approximately 5 N.

A-5.2.2 *Silver Nitrate Solution* — 5 percent (*m/v*).

A-5.2.3 *Standard Chloride Solution* — Dissolve 0.1649 g of sodium chloride in water and make up the volume to 1000 ml. Pipette out 10 ml of this solution and dilute again with water to 100 ml. One millilitre of the final solution contains 0.01 mg of chloride (as Cl).

A-5.3 Procedure for Pure and Technical Grades

A-5.3.1 Dilute 25.0 g of the material up to the mark with water in a 250-ml volumetric flask. Filter the solution if it is opalescent. If opalescence persists, it may be removed by shaking with petroleum hydrocarbon solvent (*see* IS : 1745-1978†). Transfer 50 ml of this solution in case of pure grade and 20 ml in the case of technical grade of the material to a Nessler cylinder, add 2 ml of nitric acid and make the volume to the mark with water. Add 1 ml of silver nitrate solution and mix well. Carry out a control test with 7.5 ml of standard chloride solution in case of pure grade and 7 ml in the case of technical grade in place of the material. Allow the cylinders to stand in dark for 5 minutes and then compare the opalescence of the solutions.

A-5.3.2 The limits prescribed in Table 1 shall be taken as not having been exceeded if the opalescence produced in the test with the material is not greater than that produced in the control test.

A-5.4 Procedure for Analytical Reagent Grade

A-5.4.1 Dilute 25 g of the material with 50 ml of water in a Nessler cylinder, add 10 ml of dilute nitric acid and make up to 100 ml with water. Add 1 ml of silver nitrate solution, stir immediately with a glass rod, set aside for 5 minutes and compare the opalescence produced with that produced in another Nessler cylinder using 2.5 ml of standard chloride solution instead of the material.

A-5.4.2 The limit prescribed in Table 1 shall be taken as not having been exceeded if the opalescence produced in the test with the material is not greater than that produced in the control test.

*Specification for Nessler cylinders.

†Specification for petroleum hydrocarbon solvents (*second revision*).

A-6. TEST FOR IRON

A-6.0 Outline of the Method — An extract of residue on evaporation of the material in hydrochloric acid is treated with thioglycollic acid and ammonium hydroxide. The colour developed is then compared with that of a standard solution of iron treated similarly.

A-6.1 Apparatus

A-6.1.1 Nessler Cylinders — 50-ml capacity.

A-6.2 Reagents

A-6.2.1 Concentrated Hydrochloric Acid — conforming to IS : 265-1976*.

A-6.2.2 Thioglycollic Acid — 50 percent (*m/v*).

A-6.2.3 Ammonium Hydroxide — relative density 0.92 at 25/25°C.

A-6.2.4 Standard Iron Solution — Dissolve 0.702 g of ferrous ammonium sulphate [$\text{FeSO}_4 \cdot (\text{NH}_4)_2 \text{SO}_4 \cdot 6\text{H}_2\text{O}$] in water containing 10 ml of concentrated sulphuric acid and dilute with water to 1 000 ml. Pipette 10 ml of this solution and dilute to 100 ml. One millilitre of the solution contains 0.01 mg of iron (as Fe).

A-6.3 Procedure — Heat the residue obtained under **A-4.1** to a uniform dull red heat and continue heating until fumes are no longer evolved. Allow the basin to cool. Add 5 ml of concentrated hydrochloric acid followed by 10 ml of water. Warm to dissolve, cool and transfer the solution to a 100-ml volumetric flask, filtering, if necessary, to obtain a clear solution. Dilute to the mark with water and mix well.

A-6.3.1 Transfer 25 ml of the solution to a Nessler cylinder, add 2 drops (approximately 0.1 ml) of thioglycollic acid and then ammonium hydroxide drop by drop until a pink colour just persists after stirring. Add a further 0.5 ml of ammonium hydroxide, dilute to 50 ml with water and mix well. Carry out a control test using 5 ml of standard iron solution in case of pure grade and 2.5 ml in the case of analytical reagent grade and the same quantities of other reagents in the same total volume of the reaction mixture. Compare the colour in the two tubes.

A-6.4 The limit prescribed in Table 1 shall be taken as not having been exceeded if the colour produced in the test with the material is not darker than that produced in control test.

*Specification for hydrochloric acid (*second revision*).

A-7. TEST FOR SULPHATES

A-7.0 Outline of the Method — A known quantity of the material is evaporated to dryness with sodium carbonate solution, the residue is extracted with hydrochloric acid and then treated with barium chloride solution. The turbidity, if any, is compared with the turbidity produced in a standard sulphate solution treated with hydrochloric acid and barium chloride solution.

A-7.1 Apparatus

A-7.1.1 Nessler Cylinders — 50-ml capacity (see IS : 4161-1967*).

A-7.2 Reagents

A-7.2.1 Sodium Carbonate Solution — 1 N approximately.

A-7.2.2 Dilute Hydrochloric Acid — 1 N approximately.

A-7.2.3 Barium Chloride Solution — Dissolve 10 g of barium chloride crystals in water and make up to 100 ml.

A-7.2.4 Standard Sulphate Solution — Dissolve 0.1814 g of potassium sulphate in water and make up the volume to 1 000 ml. Pipette 10 ml of this solution and dilute to 100 ml. One millilitre of this solution is equivalent to 0.01 mg of sulphate (as SO_4).

A-7.2.5 Standard Sulphuric Acid — 0.01 N.

A-7.3 Procedure for Pure and Technical Grades — Transfer 50 ml in case of pure grade and 20 ml in the case of technical grade of solution prepared under **A-5.3.1** into a 250-ml beaker, and add 0.2 ml of sodium carbonate solution. Evaporate it to dryness on a water bath. Dissolve the residue in 15 ml of water, add 1 ml of dilute hydrochloric acid, filter and collect the filtrate in one of the Nessler cylinders. Add 2 ml of barium chloride solution, dilute to 50 ml, mix well, set aside for 5 minutes and mix again. Carry out a control test in the other Nessler cylinder using 7.5 ml of standard sulphate solution in case of pure grade and 7 ml in the case of technical grade in place of the material and the same quantities of other reagents in the same total volume of the reaction mixture. Stir the solution immediately with glass rod and set aside for 5 minutes. Compare the turbidities produced in the two cylinders.

A-7.4 Procedure for Analytical Reagent Grade

A-7.4.1 Transfer 50 g of the material into a 250-ml beaker and add 0.2 ml of sodium carbonate solution. Evaporate it to dryness on a water bath. Dissolve the residue in 15 ml of water and add 1 ml of dilute hydrochloric

*Specification for Nessler cylinders.

acid, filter and collect the filtrate in one of the Nessler cylinders. Add 2 ml of barium chloride solution, dilute to 50 ml, mix well, set aside for 5 minutes and mix again. Carry out a control test in the other Nessler cylinder using 5.0 ml of standard sulphate solution in place of the material and the same quantities of other reagents in the same total volume of the reaction mixture. Stir the solution immediately with glass rod and set aside for 5 minutes. Compare the turbidities produced in the two cylinders.

A-7.4.2 The limits prescribed in Table 1 shall be regarded as not having been exceeded if the turbidity produced in the test with the material is not greater than that produced in the control test.

A-8. TEST FOR HEAVY METALS

A-8.0 Outline of the Method — A known quantity of the material is treated with ammonium hydroxide and then with sodium sulphide. A standard solution of lead nitrate is also similarly treated with equal amounts of the reagents and the colours are compared.

A-8.1 Apparatus

A-8.1.1 Nessler Cylinders — 50-ml capacity (see IS : 4161-1967*).

A-8.2 Reagents

A-8.2.1 Ammonium Hydroxide — relative density 0.92 at 25/25°C.

A-8.2.2 Litmus Paper

A-8.2.3 Sodium Sulphide Solution — solution of sodium sulphide crystals in water, approximately 10 percent (*m/v*).

A-8.2.4 Standard Lead Solution — Dissolve 1.60 g of lead nitrate [$\text{Pb}(\text{NO}_3)_2$] in water to produce 1 000 ml of solution. Pipette 10 ml of this solution and dilute again to 1 000 ml with water. One millilitre of the final solution is equivalent to 0.01 mg of lead (Pb).

A-8.3 Procedure — Transfer 10 g of the material in case of analytical reagent grade, 4 g in case of pure grade and 1 g in the case of technical grade in one of the Nessler cylinders. Make it just alkaline to litmus paper with ammonium hydroxide. Add sufficient water to make up the volume to 50 ml. Carry out a control test in the other Nessler cylinder using 2 ml of standard lead solution and the same quantities of other reagents in the same total volume of the reaction mixture. Add 2 drops of sodium sulphide solution to each cylinder and shake well. Compare the colour produced in the two tubes.

*Specification for Nessler cylinders.

A-8.3.1 The limits prescribed in Table 1 shall be regarded as not having been exceeded if the colour produced in the test with the material is not darker than that produced in the control test.

A-9. DETERMINATION OF FORMIC ACID

A-9.0 Outline of the Method — A known amount of the material is treated with sodium hypobromite, potassium iodide and dilute hydrochloric acid. The iodine liberated is titrated with standard sodium thiosulphate solution. From the difference in titre values, the formic acid content is calculated.

A-9.1 Reagents

A-9.1.1 Sodium Hypobromite Solution — approximately 0.1 N, prepared by dissolving, with thorough mixing, 2.8 ml of bromine and 100 ml of 2 N sodium hydroxide solution in 500 ml of water and diluting further with sufficient water to make up the volume to one litre.

A-9.1.2 Potassium Iodide Solution — approximately 25 percent (*m/v*).

A-9.1.3 Dilute Hydrochloric Acid — approximately 5 N.

A-9.1.4 Standard Sodium Thiosulphate Solution — 0.1 N.

A-9.2 Procedure — In each of two iodine flasks, place 100 ml of water and 25 ml of sodium hypobromite solution. To one flask, add about 10 g of the material, accurately weighed, and allow to stand for 5 minutes, taking precautions against loss of bromine vapour. To both flasks, add 5 ml of potassium iodide solution and then 20 ml of dilute hydrochloric acid, and titrate the liberated iodine with standard sodium thiosulphate solution.

A-9.3 Calculation — From the difference in volumes of standard sodium thiosulphate solution required for titration with the material and for the blank, find the mass of formic acid on the basis that 1 ml of normal sodium thiosulphate solution is equivalent to 0.023 g of formic acid (HCOOH), and calculate using the following formula:

$$\text{Formic acid (HCOOH), percent by mass} = \frac{2.3 (V_1 - V_2) N}{M}$$

where

V_1 = volume in ml of standard thiosulphate solution used in the blank,

V_2 = volume in ml of standard thiosulphate solution used in the test with the material,

N = normality of standard thiosulphate solution, and

M = mass in g of the material taken for the test.

A-10. DETERMINATION OF ACETALDEHYDE

A-10.0 Outline of the Method — A known excess of sodium hydrogen sulphite is added to a known amount of the material. The excess of sodium hydrogen sulphite is back titrated with standard iodine solution. A blank determination, is also carried out.

A-10.1 Reagents

A-10.1.1 Sodium Hydrogen Sulphite Solution — approximately 1.25 percent (m/v).

A-10.1.2 Standard Iodine Solution — 0.1 N.

A-10.2 Procedure — To 50 ml of water in a 250-ml glass stoppered flask, add about 10 g of the material, accurately weighed, and 10 ml of sodium hydrogen sulphite solution. Shake well and let stand for 30 minutes. Titrate the excess of sodium hydrogen sulphite with standard iodine solution. Carry out a blank determination with the same amount of sodium hydrogen sulphite solution but without the material.

A-10.3 Calculation — From the difference in volumes of standard iodine solution required in the titration with the material and in the blank determination, find the mass of acetaldehyde on the basis that 1 ml of normal iodine solution is equivalent to 0.022 g of acetaldehyde (CH_3CHO) and calculate using the following formula:

$$\text{Acetaldehyde, percent by mass} = \frac{2.2 (V_1 - V_2) N}{M}$$

where

V_1 = volume in ml of standard iodine solution used in the blank,

V_2 = volume in ml of standard iodine solution used in the test with the material,

N = normality of standard iodine solution, and

M = mass in g of the material taken for test.

A-11. TEST FOR OXIDIZABLE IMPURITIES**A-11.1 Reagents**

A-11.1.1 Potassium Permanganate Solution — 0.1 N.

A-11.2 Procedure — Dilute 25 g of acetic acid under test, up to the mark in a 250-ml volumetric flask. Transfer 5 ml of this diluted acetic acid in a 100-ml test-tube and add 0.5 ml of 0.1 N potassium permanganate solution and shake.

A-11.2.1 The material shall be taken to have passed the test if the pink colour does not entirely disappear within half a minute.

A P P E N D I X B

(Clause 5.1)

SAMPLING OF ACETIC ACID

B-1. GENERAL REQUIREMENTS OF SAMPLING

B-1.0 In drawing, preparing, storing and handling test-samples, the following precautions and directions shall be observed.

B-1.1 Samples shall be taken in a protected area with good ventilation. Keep the samples away from flame.

B-1.2 The sampling instrument shall be clean and dry.

B-1.3 The samples, the material being sampled, the sampling instrument and the containers for samples shall be protected from adventitious contamination.

B-1.4 To draw a representative sample, the contents of each container selected for sampling shall be mixed as thoroughly as possible by shaking or stirring or both, or by rolling, so as to bring all portions into uniform distribution.

B-1.5 The samples shall be placed in suitable, clean, dry and air-tight glass containers.

B-1.6 The sample containers shall be of such a size that they are almost but not completely filled by the sample.

B-1.7 Each sample container shall be sealed air-tight with a suitable stopper after filling and marked with the manufacturer's name or trade-mark, the month and year of manufacture of the material, the batch number (if available), and other details of sampling, such as the date of sampling and sampler's name.

B-1.8 Samples shall be stored in such a manner that the temperature of the material does not vary unduly from the normal temperature.

B-2. SAMPLING INSTRUMENTS

B-2.1 The following forms of sampling instruments may be used:

- a) Weighted sampling can for taking samples from various depths in large tanks, and
- b) Sampling tube.

B-2.2 Weighted Sampling Can — of suitable capacity, 500 to 1 000 ml, and of such a mass as to sink readily in the material to be sampled. It has a long chain or cord attached to permit filling at any desired level (*see* Fig. 2). The metal used to weigh the apparatus shall be fitted externally as irregularities in the metal are likely to contaminate the sample if the mass is fitted internally.

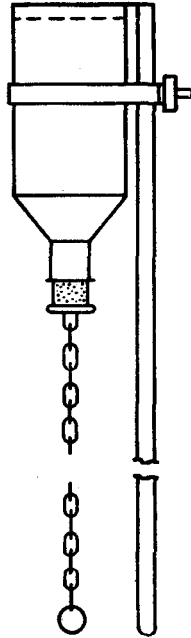

FIG. 2 WEIGHTED SAMPLING CAN

B-2.3 Sampling Tube — It is made of metal or thick glass and is 20 to 40 mm in diameter and 400 to 800 mm in length (*see* Fig. 3). The upper and lower ends are conical and reach 5 to 10 mm diameter at the narrow ends. Handling is facilitated by two rings at the upper ends. For taking a sample, the apparatus is first closed at the top with the thumb or a stopper and lowered until the desired depth is reached. It is then opened for a short time to admit the material and finally closed and withdrawn.

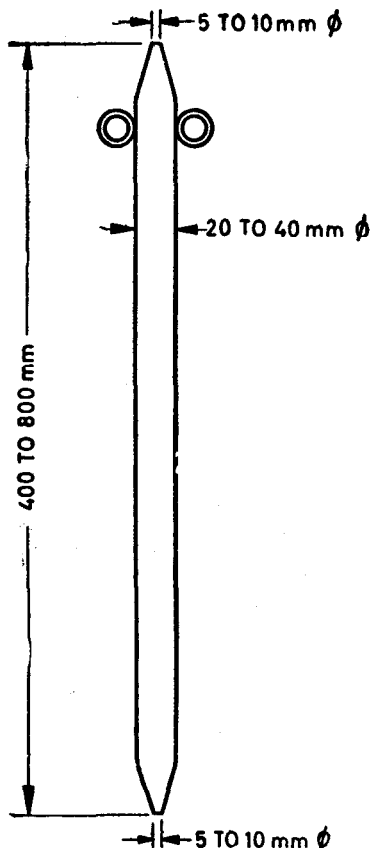

FIG. 3 SAMPLING TUBE

B-2.3.1 For small containers, the size of the sampling tube may be altered suitably.

B-3. SCALE OF SAMPLING

B-3.1 Lot — In any consignment, all containers of same size and grade belonging to the same batch of manufacture shall constitute a lot. If a consignment is known to consist of different batches of manufacture or of different sizes of containers, the containers belonging to the same batch and size shall be grouped together and each such group shall constitute a separate lot.

B-3.2 For ascertaining the conformity of the material in a lot to the requirements of this specification, tests shall be carried out for each lot separately. For this purpose, the number of containers to be selected from a lot shall be in accordance with Table 2.

TABLE 2 SCALE OF SAMPLING

| NUMBER OF CONTAINERS IN THE LOT | NUMBER OF CONTAINERS TO BE SELECTED |
|------------------------------------|--|
| (<i>N</i>) | (<i>n</i>) |
| (1) | (2) |
| Up to 25 | 3 |
| 26 ,, 100 | 4 |
| 101 ,, 150 | 5 |
| 151 ,, 300 | 7 |
| 301 and above | 10 |

B-3.2.1 The containers shall be chosen at random from the lot. To ensure the randomness of selection, the procedure given in IS : 4905-1968* may be followed.

B-4. TEST SAMPLES AND REFEREE SAMPLES

B-4.1 Preparation of Sets of Samples for Testing Individually — Draw with an appropriate sampling instrument (*see B-2*) equal portions of the material from different parts of each freshly opened container, and selected as in **B-3.2**. Mix these small portions of the material from the same container to obtain a sample representative of the container. Keep these representative samples from different containers separately. From each representative sample, draw three equal portions of the material, each sufficient for carrying out the intended tests and transfer them into thoroughly cleaned and dry sample containers. Seal the sample containers air-tight. Thus, three sets of test samples are obtained such that each set has a test sample from each selected container. Send one each of these sets to the purchaser and the supplier. Reserve the third set as referee sample bearing the seals of the purchaser and the supplier. Keep the referee sample at a place agreed to between the purchaser and the supplier.

B-4.2 Preparation of Composite Samples — Draw with an appropriate sampling instrument (*see B-2*) equal portions of material from each container selected as in **B-3.2** and mix them thoroughly together to constitute a single composite sample. Divide this composite sample into three parts, each sufficient for carrying out the intended tests, and transfer them to thoroughly cleaned and dry sample containers. Send one each of these

*Methods for random sampling.

to the purchaser and the supplier. Reserve the third composite sample as referee sample bearing the seals of the purchaser and the supplier. Keep the referee sample at a place agreed to between the purchaser and the supplier.

B-5. NUMBER OF TESTS

B-5.1 Individual Samples — Tests for acetic acid content shall be carried out individually on each of the test samples (*see* **B-4.1**).

B-5.2 Composite Samples — Tests for determination of the remaining characteristics of this specification shall be carried out on the composite sample prepared in **B-4.2**.

B-6. CRITERIA FOR CONFORMITY

B-6.1 The material in any lot shall be accepted as conforming to the requirements of this specification if the test results satisfy the conditions of **B-6.2** and **B-6.3**.

B-6.2 For Composite Samples — Each of the test results made on the composite sample according to **B-5.2** shall satisfy the corresponding requirements of this specification.

B-6.3 For Individual Samples — For acetic acid content of individual samples according to **B-5.1**, the mean and the range of test results shall be calculated as follows:

Mean (\bar{X}) = sum of test results divided by the number of test results, and

Range (R) = difference between the maximum and the minimum value of the test results.

The expression ($\bar{X} - 0.6 R$) and ($\bar{X} + 0.6 R$) shall then be calculated. The lot shall be considered to conform to the requirement of this specification if ($\bar{X} - 0.6 R$) is greater than the minimum specified value and ($\bar{X} + 0.6 R$) is less than the maximum specified value. When the sample size is ten, the test results shall be grouped into two, each constituting five test results taking them consecutively in the same order as obtained. For each group, the range shall be calculated and the mean range \bar{R} shall be calculated by dividing the sum of the ranges by two. In the expression ($\bar{X} + 0.6 R$), R shall be replaced by \bar{R} .

BUREAU OF INDIAN STANDARDS

Headquarters:

Manak Bhavan, 9 Bahadur Shah Zafar Marg, NEW DELHI-110002

Telephones : 331 01 31

331 13 75

Telegrams : Manaksanstha
(Common to all Offices)

Regional Offices:

| | Telephone |
|---|------------------------|
| Central : Manak Bhavan, 9 Bahadur Shah Zafar Marg, NEW DELHI 110002 | 331 01 31 331 13 75 |
| *Eastern : 1/14 CIT Scheme VII M, V.I.P. Road, Maniktola, CALCUTTA 700054 | 37 86 62 |
| Northern : SCO 335-336, Sector 34-A, CHANDIGARH 160 022 | 60 38 43 |
| Southern : C.I.T. Campus, IV Cross Road, MADRAS 600113 | 235 23 15 |
| †Western : Manakalaya, E9 MIDC, Marol, Andheri (East), BOMBAY 400093 | 832 92 95 |

Branch Offices:

| | |
|--|------------|
| 'Pushpak', Nurmohamed Shaikh Marg, Khanpur, AHMADABAD 380001 | 30 13 48 |
| ‡Peenya Industrial Area, 1st Stage, Bangalore-Tumkur Road, BANGALORE 560058 | 39 49 55 |
| Gangotri Complex, 5th Floor, Bhabhada Road, T.T. Nagar, BHOPAL 462003 | 55 40 21 |
| Plot No. 21 Satyanagar, BHUBANESHWAR 751007 | 40 36 27 |
| Kalakathir Building, 8/48 Avanashi Road, COIMBATORE 641037 | 21 01 41 |
| Plot No. 43, Sector 16 A, Mathura Road, FARIDABAD 121001 | 8-28 88 01 |
| Savitri Complex, 116 G.T. Road, GHAZIABAD 201001 | 8-71 19 96 |
| 53/5 Ward No. 29, R.G. Barua Road, 5th By-lane, GUWAHATI 781003 | 54 11 37 |
| 5-8-56C L.N. Gupta Marg, Nampally Station Road, HYDERABAD 500001 | 20 10 83 |
| R 14 Yudhister Marg, C Scheme, JAIPUR 302005 | 38 13 74 |
| 117/418 B Sarvodaya Nagar, KANPUR 208005 | 21 68 76 |
| Seth Bhawan, 2nd Floor, Behind Leela Cinema, Naval Kishore Road, LUCKNOW 226001 | 23 89 23 |
| Patiputra Industrial Estate, PATNA 800013 | 26 23 05 |
| C/o Smt. Sunita Mirakhr,, 66 D/C Annexe, Gandhi Nagar, JAMMU TAWI 180004 | — |
| T.C. No. 14/1421, University P.O., Palayam, THIRUVANANTHAPURAM 695034 | 6 21 17 |

Inspection Offices (With Sale Point):

| | |
|---|----------|
| Pushpanjali, 1st floor, 205-A, West High Court Road, Shankar Nagar Square, NAGPUR 440010 | 525171 |
| Institution of Engineers (India) Building 1332 Shivaji Nagar, PUNE 411005 | 32 36 35 |

| | |
|---|-----------|
| * Sales Office is at 5 Chowringhee Approach, P.O. Princep Street, CALCUTTA 700072 | 27 99 65 |
| † Sales Office is at Novelty Chambers, Grant Road, BOMBAY 400007 | 309 65 28 |
| ‡ Sales Office is at 'F' Block, Unity Building, Narasimharaja Square, BANGALORE 560002 | 22 39 71 |