

इंटरनेट

मानक

Disclosure to Promote the Right To Information

Whereas the Parliament of India has set out to provide a practical regime of right to information for citizens to secure access to information under the control of public authorities, in order to promote transparency and accountability in the working of every public authority, and whereas the attached publication of the Bureau of Indian Standards is of particular interest to the public, particularly disadvantaged communities and those engaged in the pursuit of education and knowledge, the attached public safety standard is made available to promote the timely dissemination of this information in an accurate manner to the public.

“जानने का अधिकार, जीने का अधिकार”

Mazdoor Kisan Shakti Sangathan

“The Right to Information, The Right to Live”

“पुराने को छोड़ नये के तरफ”

Jawaharlal Nehru

“Step Out From the Old to the New”

IS 1447-2 (1992): Methods of sampling of petroleum and its products, Part 2: Sampling of liquefied petroleum gas (LPG)
[PCD 1: Methods of Measurement and Test for Petroleum, Petroleum Products and Lubricants]



“ज्ञान से एक नये भारत का निर्माण”

Satyanarayan Gangaram Pitroda

“Invent a New India Using Knowledge”



“ज्ञान एक ऐसा खजाना है जो कभी चुराया नहीं जा सकता है”

Bhartrhari—Nitiśatakam

“Knowledge is such a treasure which cannot be stolen”

BLANK PAGE



भारतीय मानक
पेट्रोलियम और इसके उत्पादों के नमूने लेने की पद्धतियाँ
[पी : 2]
द्रवित पेट्रोलियम गैसों — नमूने लेने की पद्धति
(दूसरा पुनरीक्षण)

Indian Standard
METHODS OF SAMPLING OF
PETROLEUM AND ITS PRODUCTS
[P : 2]
LIQUEFIED PETROLEUM GASES — METHOD OF SAMPLING
(*Second Revision*)

ICS 75.160.30

© BIS 2013

BUREAU OF INDIAN STANDARDS
MANAK BHAVAN, 9 BAHADUR SHAH ZAFAR MARG
NEW DELHI 110002

NATIONAL FOREWORD

This Indian Standard [P : 2] (Second Revision) which is identical with ISO 4257 : 2001 'Liquefied petroleum gases — Method of sampling' issued by the International Organization for Standardization (ISO) was adopted by the Bureau of Indian Standards on the recommendation of the Methods of Measurement and Test for Petroleum, Petroleum Products and Lubricants Sectional Committee and approval of the Petroleum, Coal and Related Products Division Council.

This standard was first published as IS 1447 : 1966 'Methods of sampling of petroleum and its products'. In light of experience gained in the country, the Committee then decided to revise and issue it as IS 1447 [P : 2] : 1992 'Methods of sampling of petroleum and its products: Part 2 Sampling of liquefied petroleum gas (LPG)'. Part 1 of IS 1447 covered 'Petroleum and its products — Methods of sampling: Part 1 Manual sampling'. The Committee has decided to revise this standard to completely align it with ISO 4257 : 2001 and publish under dual numbering system. Consequently the title of the standard has been modified.

The text of ISO Standard has been approved as suitable for publication as an Indian Standard without deviations. Certain conventions are, however, not identical to those used in Indian Standards. Attention is particularly drawn to the following:

- a) Wherever the words 'International Standard' appear referring to this standard, they should be read as 'Indian Standard'.
- b) Comma (,) has been used as a decimal marker while in Indian Standards, the current practice is to use a point (.) as the decimal marker.

For tropical countries like India, the standard temperature and the relative humidity shall be taken as $27 \pm 2^\circ\text{C}$ and 65 ± 5 percent, respectively.

In reporting the result of a test or analysis made in accordance with this standard, if the final value, observed or calculated, is to be rounded off, it shall be done in accordance with IS 2 : 1960 'Rules for rounding off numerical values (*revised*)'.

Indian Standard

METHODS OF SAMPLING OF
PETROLEUM AND ITS PRODUCTS

[P : 2]

LIQUEFIED PETROLEUM GASES — METHOD OF SAMPLING

(*Second Revision*)

WARNING — The use of this International Standard may involve hazardous materials, operations and equipment. This International Standard does not purport to address all of the safety problems associated with its use. It is the responsibility of the user of this standard to establish appropriate safety, health and environment protection practices and determine the applicability of regulatory limitations prior to use.

1 Scope

This International Standard specifies the procedure to be used for obtaining samples of unrefrigerated liquefied petroleum gases (LPG). It is suitable for sampling from bulk containers, to provide samples for laboratory testing of products covered by ISO 9162.

This International Standard is applicable for the provision of samples for compositional analysis by ISO 7941. It is not applicable for the provision of samples for trace analysis of low-boiling components. If trace analysis of low-boiling components is required, a variable-volume receiver such as that described in ASTM D 3700 should be used.

2 Term and definition

For the purposes of this International Standard, the following term and definition applies.

2.1 liquefied petroleum gases LPG

petroleum gases that can be stored and/or handled in the liquid phase under moderate conditions of pressure and at ambient temperature

NOTE These gases consist predominantly of propane, propene, butanes and butenes, with small proportions of ethane, ethene and/or pentanes and pentenes. They are normally described in terms of the predominant hydrocarbon, e.g. commercial butane or commercial propane.

3 Principle

A liquid sample is transferred from the source into a sample container through a transfer line by purging the container and filling it with liquid, then providing a liquid ullage so that 80 % (V/V) of the container volume remains filled with liquid.

NOTE For the purposes of this International Standard, the term "% (V/V)" is used to represent the volume fraction.

4 General considerations for obtaining a representative sample

Great care is required to obtain a representative sample, especially if the material to be sampled is a mixture of liquefied gases. The following factors shall be taken into account.

- a) Take samples from the liquid phase only.
- b) Avoid sampling from the bottom of a vessel.

- c) The contents of tanks can be non-homogeneous. Homogeneity can be improved by circulating the contents prior to sampling.

A waiting period of 30 min is recommended after circulation before sampling to permit settling of any aqueous material and to allow dissipation of any static charge that may have developed.

- d) When sampling from pipelines under flow conditions, the pressure in the line needs to be above vapour pressure to avoid two-phase conditions.

5 Safety precautions

5.1 General

Because of the hazards involved, liquefied gases shall be sampled only by, or under the supervision of, persons familiar with the necessary safety precautions. Three areas of safety shall be considered:

- a) safety at the sampling point;
- b) safety of the container;
- c) safety during transport.

5.2 Safety at the sampling point

Care shall be taken to avoid contact by liquid LPG with the skin. Protective gloves and goggles shall be worn, and care shall be taken to avoid breathing vapours.

Discharge of LPG can give rise to static electricity. Equipment shall be electrically grounded or bonded to the LPG tank before commencing and throughout the sampling operations.

During purging and ullaging, safe means for disposal of waste vapours and liquids shall be provided. Compliance with local safety requirements and environmental regulations is necessary.

5.3 Safety of the container

Sample containers for use under pressure shall have been pressure-tested and shall be in accordance with national or local regulations, and the maximum safe operating pressure shall be marked on the container. Sampling operators shall ensure that the pressure rating of the container is suitable for use with the product to be sampled and the conditions under which it is to be handled. Containers shall have been checked for gas tightness.

Containers shall not be overfilled. There shall always be sufficient ullage space to allow liquid expansion under all storage and transport conditions. Carefully follow the procedure in clause 8, especially 8.4.

Before use, check that the valves and pressure cylinder are not damaged. It is recommended that a frame collar, preferably square-shaped, be fitted around each valve to protect it from accidental damage during use, transport and storage.

Containers shall be placed in a cool location, shaded from direct sunshine, as soon as possible after taking the sample. Keep the sample cool until testing is completed or provide a means of avoiding excessive variation in its temperature.

5.4 Safety during transport

Precautions shall be taken to protect the integrity of the container by packing the container in a crate in accordance with regulatory requirements and by using a protective cap on the valves so that accidental unseating of the valves or tampering with them is prevented. It is recommended that valves should always be capped.

6 Apparatus

6.1 Sample container

Use metal sampling containers and fittings of a type that ensure maximum safety and are corrosion-resistant to the product being sampled. A suitable material is stainless steel; an aluminium sample container shall not be used. The size of the container depends upon the amount of sample required for the laboratory tests that are to be made. If the container is to be transported, it shall conform to national or international regulations for the transportation of hazardous materials.

The sampling container shall be of the two-valve type with an ullage tube as shown in Figure 1. The end of the container at which the ullage tube is fitted shall be clearly and indelibly marked. The length of the tube is such that the volume V_1 (see Figure 1) represents 20 % (V/V) of the total capacity of the container. Total capacity = $V_1 + V_2$, with $V_2 = 4 \times V_1$.

Single-valve containers shall not be used (see note 1 hereafter).

Clearly label the cylinder with the following information:

- cylinder number;
- place at which the sample was taken;
- ship's name (if appropriate);
- ship's tank number (if appropriate);
- shore tank number (if appropriate);
- method of sampling;
- date and time of sampling;
- description of the product;
- initials or other identifying mark of the operator;
- destination of the cylinder;
- any further information relevant to the laboratory concerning the sample and the condition of the cylinder.

NOTE 1 The single-valve containers present the following disadvantages:

- without ullage tube, safety is not ensured;
- with ullage tube, they cannot be purged and cleaned adequately with solvents.

NOTE 2 The valves can be of the same type as those which fit commercially available LPG cylinders.

6.2 Sample transfer line

Transfer lines shall be made of a material, preferably metal, that is impervious to the product to be sampled and capable of withstanding without leakage the pressure to which it is exposed in the procedure. They shall be equipped with two valves in addition to that at the product source and those on the container: a control valve (designated A in Figure 2) and a vent valve (designated B in Figure 2). Between valves A and B, a pressure relief valve shall be installed, which shall be vented to a safe place.

The transfer line between the T-union directly above the vent valve B which connects to the sample container at valve C in Figure 2 shall be constructed from "armoured flexible tubing".

6.3 Connection to sample container

Use metal sample connectors.

7 Preparing the sample container

7.1 If the sample container (6.1) has been used for sampling an uncontaminated product, drain the sample container and proceed as indicated in 7.3.

7.2 If the sample container (6.1) has been used for sampling a contaminated product, or if the previous use of the sample container is unknown, carry out the operations below in strict order:

- a) drain the sample container (6.1);
- b) clean it with volatile solvents (see note hereafter);
- c) dry it under vacuum;
- d) purge the air from the container with clean, dry gaseous propane and maintain this condition by closing the valves.

NOTE As volatile solvents, acetone followed by pentane are preferred.

7.3 After being connected to the sample transfer line, the sample container (6.1) shall be purged using procedure 8.2.

8 Procedure

8.1 Purging the sample transfer line

Connect the ends of the transfer line to the product source and to the valve C of the container. Close the control valve A, vent valve B and the valve C (see Figure 1). Open the valve at the product source and purge the transfer line by opening the control valve A and the vent valve B.

8.2 Purging the sample container

With the container (6.1) in an upright position and its valve D fitted with an ullage tube at the top, close vent valve B and valve C, and open control valve A. Open valve C, and partly fill the container with sample by slowly opening the valve D. Close the control valve A, and allow part of the sample to escape in the vapour phase through valve D. Close valve D and swing the sample container through 180° into the reverse vertical position. Return the container to the upright position with valve D on the top, and release the remainder of the sample in the liquid phase by opening vent valve B. Repeat the purging operation at least three times.

NOTE Repeated purging will adequately dilute any residual material from previous operations so that the sample is representative.

8.3 Transfer of sample

With the container (6.1) in an upright position and its valve D fitted with an ullage tube at the top, close vent valve B and valve C, open control valve A and valve C, and fill the container with sample. Close the valve C and the valve at the product source. Open the vent valve B. After the pressure in the transfer line is fully released, disconnect it from the source and from the sample container. Discard the sample if a leak develops or if either of the container's two valves is opened during handling of the sample container before performing the operations outlined in 8.4.

8.4 Sample ullage

For safety, immediately after the sample has been obtained, provide a partial ullage in the sample container by the following procedure:

Place the sample container in an upright position with the valve D fitted with an ullage tube uppermost and immediately open the upper valve slightly. Allow the excess liquid to escape and close the valve at the first sign of vapour. If no liquid escapes, discard the sample and refill the container.

8.5 Checking for leaks

After the excess liquid has been eliminated so that 80 % (V/V) of the sample remains, the container shall be checked for leaks by a suitable procedure, such as immersion in a water bath. If a leak is detected at any time during the sampling operation, discard the sample. Repair or replace a leaky container before obtaining another sample.

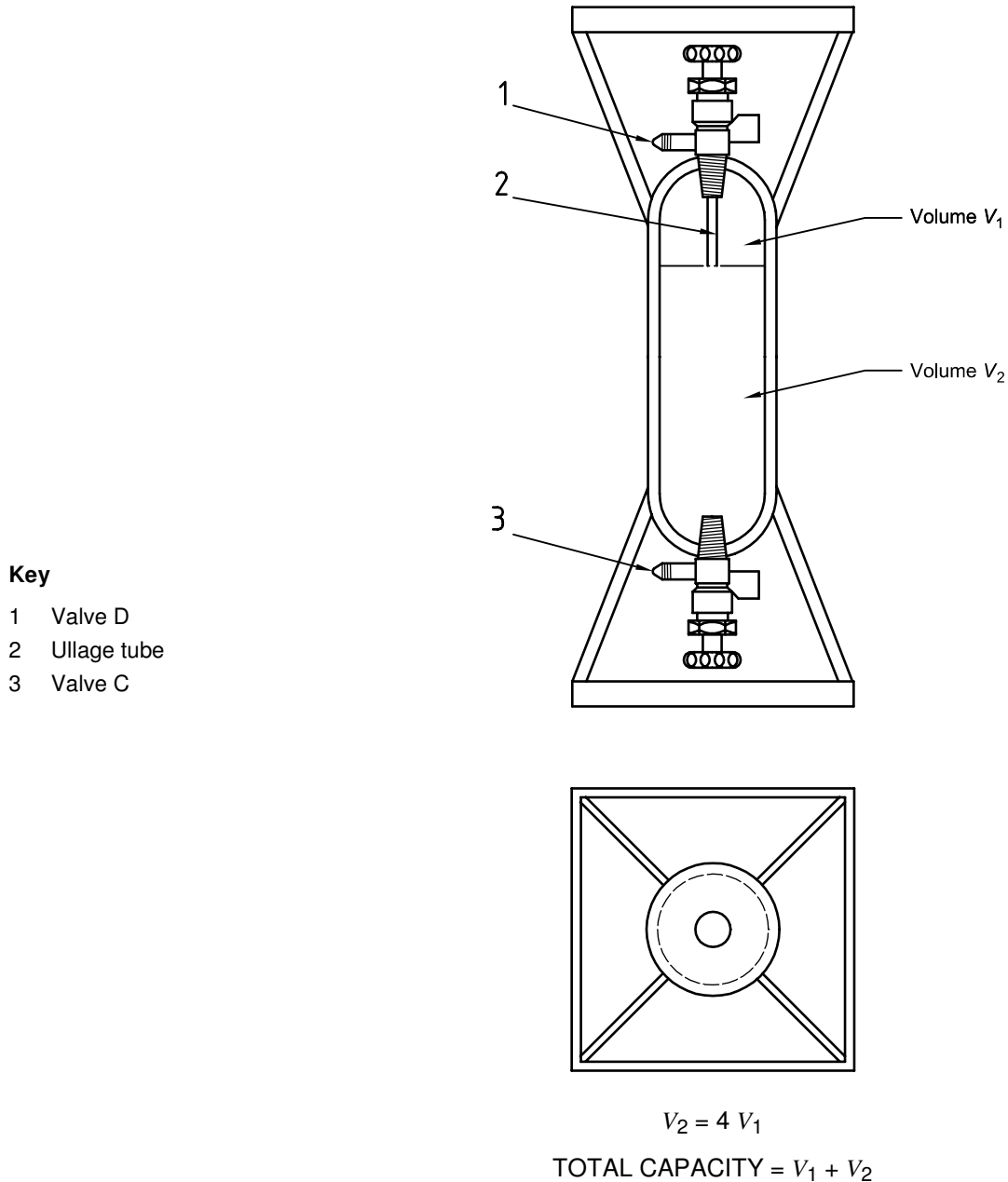

NOTE To enable the maximum drainage of liquid, the stem of valve D should not protrude beyond the inner surface of the container.

Figure 1 — Two-valve container with ullage tube

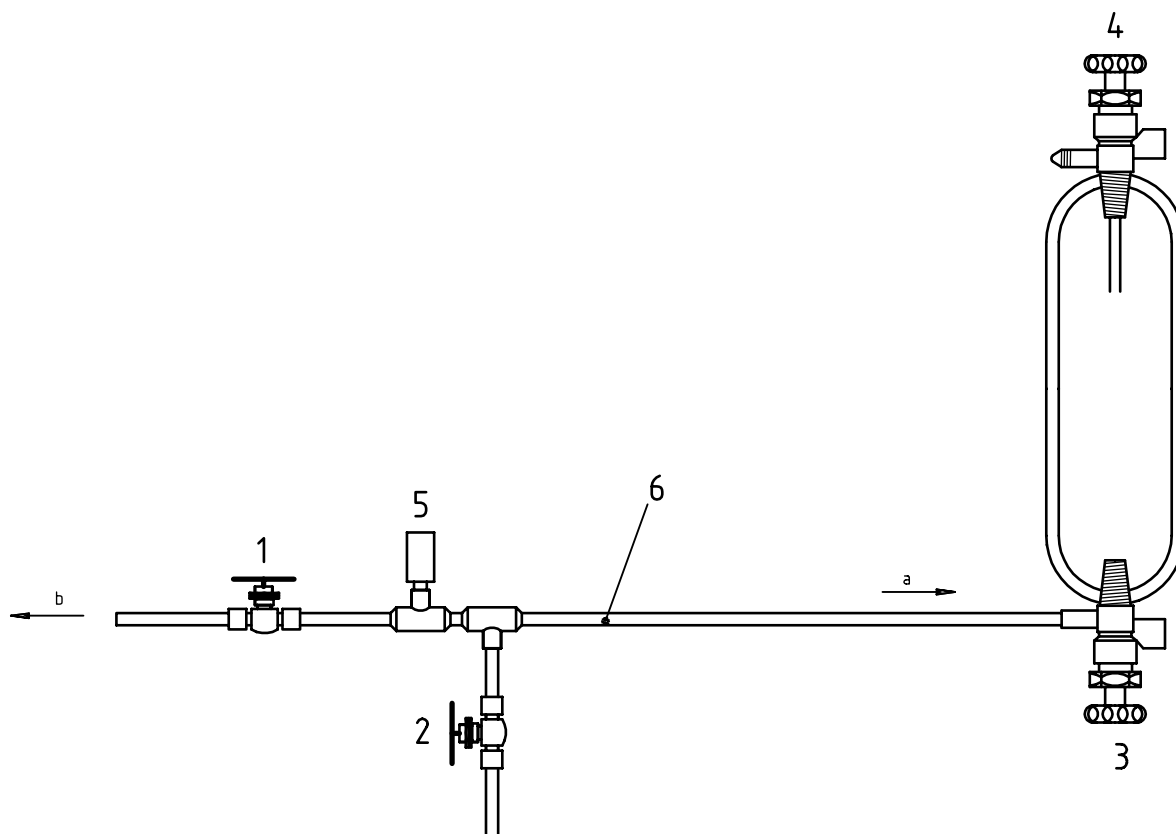

Key

- 1 Control valve A
- 2 Vent valve B
- 3 Valve C
- 4 Valve D
- 5 Pressure-relief valve
- 6 Armoured flexible tubing

a To valve C.

b To product source sampling valve.

Figure 2 — Sample container and transfer line

Bibliography

- [1] ISO 7941, *Commercial propane and butane — Analysis by gas chromatography.*
- [2] ISO 9162, *Petroleum products — Fuels (class F) — Liquefied petroleum gases — Specifications.*
- [3] ASTM D 3700-94, *Standard Practice for Containing Hydrocarbon Fluid Samples Using a Floating Piston Cylinder.*

Bureau of Indian Standards

BIS is a statutory institution established under the *Bureau of Indian Standards Act, 1986* to promote harmonious development of the activities of standardization, marking and quality certification of goods and attending to connected matters in the country.

Copyright

BIS has the copyright of all its publications. No part of these publications may be reproduced in any form without the prior permission in writing of BIS. This does not preclude the free use, in course of implementing the standard, of necessary details, such as symbols and sizes, type or grade designations. Enquiries relating to copyright be addressed to the Director (Publications), BIS.

Review of Indian Standards

Amendments are issued to standards as the need arises on the basis of comments. Standards are also reviewed periodically; a standard along with amendments is reaffirmed when such review indicates that no changes are needed; if the review indicates that changes are needed, it is taken up for revision. Users of Indian Standards should ascertain that they are in possession of the latest amendments or edition by referring to the latest issue of 'BIS Catalogue' and 'Standards: Monthly Additions'.

This Indian Standard has been developed from Doc No.: PCD 1 (2549).

Amendments Issued Since Publication

Amendment No.	Date of Issue	Text Affected

BUREAU OF INDIAN STANDARDS

Headquarters:

Manak Bhavan, 9 Bahadur Shah Zafar Marg, New Delhi 110002

Telephones: 2323 0131, 2323 3375, 2323 9402

Website: www.bis.org.in

Regional Offices:

Telephones

Central	: Manak Bhavan, 9 Bahadur Shah Zafar Marg NEW DELHI 110002	{ 2323 7617 2323 3841
Eastern	: 1/14, C.I.T. Scheme VII M, V.I.P. Road, Kankurgachi KOLKATA 700054	{ 2337 8499, 2337 8561 2337 8626, 2337 9120
Northern	: SCO 335-336, Sector 34-A, CHANDIGARH 160022	{ 260 3843 260 9285
Southern	: C.I.T. Campus, IV Cross Road, CHENNAI 600113	{ 2254 1216, 2254 1442 2254 2519, 2254 2315
Western	: Manakalaya, E9 MIDC, Marol, Andheri (East) MUMBAI 400093	{ 2832 9295, 2832 7858 2832 7891, 2832 7892

Branches: AHMEDABAD. BANGALORE. BHOPAL. BHUBANESHWAR. COIMBATORE. DEHRADUN. FARIDABAD. GHAZIABAD. GUWAHATI. HYDERABAD. JAIPUR. KANPUR. LUCKNOW. NAGPUR. PARWANOO. PATNA. PUNE. RAJKOT. THIRUVANATHAPURAM. VISAKHAPATNAM.