

इंटरनेट

मानक

### Disclosure to Promote the Right To Information

Whereas the Parliament of India has set out to provide a practical regime of right to information for citizens to secure access to information under the control of public authorities, in order to promote transparency and accountability in the working of every public authority, and whereas the attached publication of the Bureau of Indian Standards is of particular interest to the public, particularly disadvantaged communities and those engaged in the pursuit of education and knowledge, the attached public safety standard is made available to promote the timely dissemination of this information in an accurate manner to the public.

“जानने का अधिकार, जीने का अधिकार”

Mazdoor Kisan Shakti Sangathan

“The Right to Information, The Right to Live”

“पुराने को छोड़ नये के तरफ”

Jawaharlal Nehru

“Step Out From the Old to the New”

IS 8243-2 (1993): Vapour vacuum pumps - Methods of measurement of performance characteristics, Part 2: Measurement of critical backing pressure [MED 17: Chemical Engineering Plants and Related Equipment]



“ज्ञान से एक नये भारत का निर्माण”

Satyanarayan Gangaram Pitroda

“Invent a New India Using Knowledge”



“ज्ञान एक ऐसा खजाना है जो कभी चुराया नहीं जा सकता है”

Bhartihari—Nitiśatakam

“Knowledge is such a treasure which cannot be stolen”



BLANK PAGE



IS 8243 ( Part 2 ) : 1993  
ISO 1608-2 : 1989

भारतीय मानक

वाष्प निर्वात पंप – कार्यकारिता लक्षण का मापन

भाग 2 क्रांतिक पृष्ठक दाब मापन

( पहला पुनरीक्षण )

*Indian Standard*

VAPOUR VACUUM PUMPS — MEASUREMENT OF  
PERFORMANCE CHARACTERISTICS

PART 2 MEASUREMENT OF CRITICAL BACKING PRESSURE

*( First Revision )*

UDC 621.52 : 620.16

© BIS 1993

**BUREAU OF INDIAN STANDARDS**

MANAK BHAVAN, 9 BAHADUR SHAH ZAFAR MARG

NEW DELHI 110002

September 1993

Price Group 2

## NATIONAL FOREWORD

This Indian Standard ( First Revision ) which is identical with ISO 1608-2 : 1989 'Vapour vacuum pumps — Measurement of performance characteristics : Part 2 Measurement of critical backing pressure', issued by the International Organization for Standardization ( ISO ), was adopted by the Bureau of Indian Standards on the recommendation of the Chemical Engineering Plants and Related Equipment Sectional Committee ( HMD 17 ) and approval of the Heavy Mechanical Engineering Division Council.

This standard was first issued in 1976 as 'Methods of measurement of the performance characteristics of vapour vacuum pumps: Part 2 Measurement of critical backing pressure'. Consequent upon the publication of ISO 1607-2 : 1989, this standard ( including its title ) has been revised by adopting ISO 1607-2 : 1989, to bring it in alignment with international practices.

The text of ISO standard has been approved as suitable for publication as Indian Standard without deviations. Certain conventions are, however, not identical to those used in Indian Standards. Attention is particularly drawn to the following:

- a) Wherever the words 'International Standard' appear referring to this standard, they should be read as 'Indian Standard'.
- b) Comma ( , ) has been used as a decimal marker in the International Standard while in Indian Standards, the current practice is to use a point ( . ) as the decimal marker.

This Indian Standard has been issued in two parts. This Part 2 of the standard covers measurement of critical backing pressure and measurement of volume rate of flow ( pumping speed ) is covered in Part 1 of this standard.

In reporting the results of a test or analysis made in accordance with this standard, if the final value, observed or calculated, is to be rounded off, it shall be done in accordance with IS 2 : 1960 'Rules for rounding off numerical values ( revised )'.

## *Indian Standard*

# VAPOUR VACUUM PUMPS — MEASUREMENT OF PERFORMANCE CHARACTERISTICS

## PART 2 MEASUREMENT OF CRITICAL BACKING PRESSURE

### *( First Revision )*

## 1 Scope

**1.1** This part of ISO 1608 specifies a method of measuring the critical backing pressure of vapour vacuum pumps.

NOTE — The critical backing pressure is that backing pressure above which the operating conditions of the pump are affected in such a manner that its performance ceases to be satisfactory.

The dependence of the performance of a vapour pump on the backing pressure can only be completely described by means of a curve relating the inlet and backing pressures over the range of operation.

In many cases it is adequate to specify the critical backing pressure by a single parameter, which is defined in 2.1. In some cases, however, especially where ultra-high vacuum performance is of interest, or where gases such as hydrogen and helium are concerned, the complete curve may be required.

**1.2** The pumps considered comprise the following three classes of oil and mercury vapour pumps:

- vapour jet vacuum pump;
- diffusion pumps;
- diffusion-ejector pumps.

## 2 Definitions

For the purposes of this part of ISO 1608, the following definitions apply.

### 2.1 critical backing pressure:

**2.1.1** General case — For a stated throughput, the lowest value of the backing pressure at which a small percentage increment in the backing pressure causes a specified percentage rise in the inlet pressure.

NOTE — For the purposes of this part of ISO 1608, the minimum value of this specified increment is 10 %.

**2.1.2** “nc-load” critical backing pressure: The value of the critical backing pressure corresponding to zero admitted throughput.

**2.1.3** “full-load” critical backing pressure: The value of the critical backing pressure corresponding to the maximum throughput for stable operation of the pump.

**2.2** test dome; test header: A chamber of specific form and dimensions attached to the inlet of the pump through which a measured flow of gas may be admitted to the pump, and which is equipped with means of pressure measurement.

**2.3** ultimate pressure: The limiting pressure approached asymptotically in the dome, with the gas inlet valve closed and the pump in normal operation.

NOTE — In practice, the limiting pressure is considered as having been reached after pumping for sufficient time to establish that further reduction in pressure will be negligible.

## 3 Apparatus

**3.1** Test dome, as shown in figure 1 and described in ISO 1608-1.

The general arrangement of the test equipment should be as shown in figure 2. The following equipment is required:

- 1) A controllable valve (A) for admitting gas to the test dome, combined with a suitable throughput-measuring device.
- 2) A controllable gas admittance valve (B), mounted at the inlet on the backing pump, to regulate the backing pressure.

The length of the backing line between the valve (B) and the place of attachment of the gauge tubulation attachment should be more than 200 mm (see figure 2).

- 3) A gauge (C) for measuring the pressure in the backing line adjacent to the outlet of the vapour pump. This gauge is fitted in a straight uniform portion of the backing line, the diameter of which should be equal to that of the outlet of the vapour pump. Its tubulation should be perpendicular to the axis of this portion of the backing line and should terminate flush with its internal surface.

The tubulation dimensions of the gauge (C) should ensure its maximum conductance. The length of the backing line between the place of the gauge tubulation attachment should not exceed 150 mm.

- 4) A gauge (D) for measuring the pressure in the test dome. This gauge shall not protrude into the test dome more than 0,5 times the gauge tubulation diameter ( $d_2$ ).

The gauges for the measurement of pressure shall be calibrated to an accuracy within  $\pm 5\%$  for pressures above or equal to 1 Pa<sup>1)</sup> and within  $\pm 10\%$  for lower pressures.

**3.2 Test gas:** dried air should be used unless otherwise specified.

NOTE — The drying of the air by means of silica-gel, for example, is normally adequate.

## 4 Test method

### 4.1 General

For the purpose of measurement of the critical backing pressure, the vapour pump shall be run with the prescribed quantity and type of pump fluid, heating power and cooling specified by the manufacturer.

The room temperature shall be between 15 °C and 25 °C throughout the test. The pump shall have reached its thermal equilibrium before the tests are carried out. The dome shall be evacuated until the limit pressure is obtained before the introduction of any gas.

In these conditions, the temperature of the apparatus above the pump inlet (see figure 1) and of the piping between the pump outlet flange and valve B (see figure 2) should be steady to  $\pm 1\text{ °C}$  and shall be between 15 °C and 25 °C.

NOTE — The critical back pressure may be measured at other room temperatures. If it is, the operating conditions for the measuring instruments used should be adequately provided.

### 4.2 "No-load" procedure

When the limit pressure has been reached in the test header, the gas admittance valve (B) in the backing line is gradually opened and the backing pressure increased in small increments. This is continued until the condition specified in the note to 2.1.1 is approximately located. This critical region is then explored in more detail by appropriate manipulation of the admittance valve (B). A curve of the inlet pressure as a function of the backing pressure is derived. The point on this curve corresponding to the condition specified in the note to 2.1.1 then identifies the "no-load" critical backing pressure. The initial pressure in the backing line with no gas flow should be less than 10 % of the measured critical backing pressure.

### 4.3 "Full load" and intermediate load procedures

**4.3.1** The gas admittance valve (A) on the test header is then opened until a desired vapour pump inlet pressure is reached, and the throughput measured. The procedure of admitting gas through valve (B) as described in 4.2 is then repeated, valve (B) being closed between successive operations, until the maximum throughput for normal stable pump operation is reached.

NOTE — The maximum throughput for normal stable pump operation may depend on the flow rate of the backing pump. When this flow rate is not larger than the value corresponding to the rated maximum throughput for normal operation of a vapour pump divided by the critical backing pressure at this throughput, it is necessary that this test procedure be carried out using a sufficiently large capacity backing pump to allow the attainment of this rated maximum throughput.

**4.3.2** During the tests described in 4.2 and 4.3.1, the power input to the vapour pump shall be kept within  $\pm 4\%$  of its nominal value, and shall be held within these limits for at least 30 min prior to the commencement of the test. The cooling rate shall be maintained constant to within  $\pm 10\%$  of the value recommended by the manufacturer.

## 5 Test report

### 5.1 Test results

The critical backing pressure should be expressed in pascals (Pa) and the throughput in pascal litres per second (Pa·l/s). The relation between the critical backing pressure and the throughput of gas should be shown on a graph unless otherwise specified. The percentage rise in inlet pressure used to define the critical backing pressure in 2.1.1 shall be noted on this graph.

In cases where there is no abrupt increase in the pressure on the high vacuum side, a curve showing the relationship between the backing pressure and the pressure on the high vacuum side with no throughput should be provided.

### 5.2 Test conditions

All reports of test results should include a statement of the following conditions existing during the test:

- a) type and conditions of operation of all gauges used;
- b) heating power of the pump and limits of variation during the test;
- c) maximum and minimum inlet and outlet temperatures of vapour pump cooling water or refrigerant during the test, if applicable;
- d) cooling water flow rate, if applicable;
- e) maximum and minimum ambient temperatures during the test;
- f) type and quantity of the vapour pump fluid;
- g) where applicable, any special features of the heat transfer to the environment.

1) 100 Pa = 100 N/m<sup>2</sup> = 1 mbar

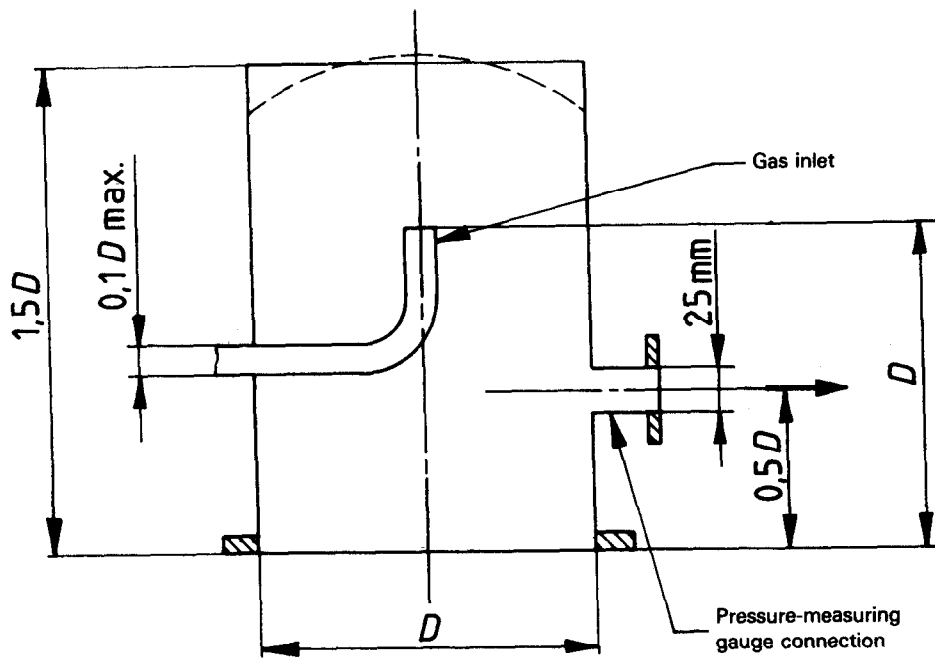

Figure 1 – Test dome

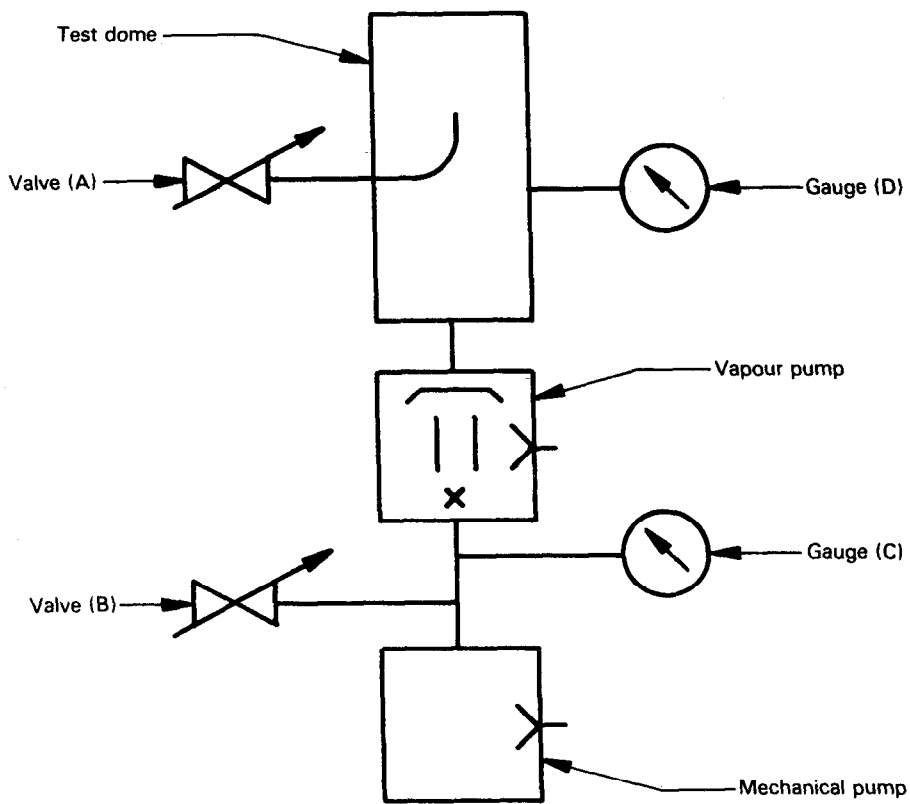

Figure 2 – Arrangement of test equipment



**Standard Mark**

The use of the Standard Mark is governed by the provisions of the *Bureau of Indian Standards Act, 1986* and the Rules and Regulations made thereunder. The Standard Mark on products covered by an Indian Standard conveys the assurance that they have been produced to comply with the requirements of that standard under a well defined system of inspection, testing and quality control which is devised and supervised by BIS and operated by the producer. Standard marked products are also continuously checked by BIS for conformity to that standard as a further safeguard. Details of conditions under which a licence for the use of the Standard Mark may be granted to manufacturers or producers may be obtained from the Bureau of Indian Standards.

## Bureau of Indian Standards

BIS is a statutory institution established under the *Bureau of Indian Standards Act, 1986* to promote harmonious development of the activities of standardization, marking and quality certification of goods and attending to connected matters in the country.

### Copyright

BIS has the copyright of all its publications. No part of these publications may be reproduced in any form without the prior permission in writing of BIS. This does not preclude the free use, in the course of implementing the standard, of necessary details, such as symbols and sizes, type or grade designations. Enquiries relating to copyright be addressed to the Director (Publications), BIS

### Revision of Indian Standards

Amendments are issued to standards as the need arises on the basis of comments. Standards are also reviewed periodically; a standard along with amendments is reaffirmed when such review indicates that no changes are needed; if the review indicates that changes are needed, it is taken up for revision. Users of Indian Standards should ascertain that they are in possession of the latest amendments or edition by referring to the latest issue of 'BIS Handbook' and 'Standards Monthly Additions'. Comments on this Indian Standard may be sent to BIS giving the following reference:

Doc : No. HMD 17 ( 0169 )

### Amendments Issued Since Publication

Amend No.	Date of Issue	Text Affected

## BUREAU OF INDIAN STANDARDS

### Headquarters:

Manak Bhavan, 9 Bahadur Shah Zafar Marg, New Delhi 11002  
Telephones : 331 01 31, 331 13 75

Telegrams : Manaksanstha  
Common to all Offices )

### Regional Offices :

Central : Manak Bhavan, 9 Bahadur Shah Zafar Marg  
NEW DELHI 110002

Telephone

{ 331 01 31  
331 13 75

Eastern : 1/14 C. I. T. Scheme VII M, V. I. P. Road, Maniktola  
CALCUTTA 700054

{ 37 84 99, 37 85 61  
37 86 26, 37 86 62

Northern : SCO 445-446, Sector 35-C, CHANDIGARH 160036

{ 53 38 43, 53 16 40  
53 23 84

Southern : C. I. T. Campus, IV Cross Road, MADRAS 600113

{ 235 02 16, 235 04 42  
235 15 19, 235 23 15

Western : Manakalaya, E9 MIDC, Marol, Andheri ( East )  
BOMBAY 400093

{ 632 92 95, 632 78 58  
632 78, 91, 632 78 92

Branch : AHMADABAD. BANGALORE. BHOPAL. BHUBANESHWAR. COIMBATORE.  
FARIDABAD. GHAZIABAD. GUWAHATI. HYDERABAD. JAIPUR. KANPUR  
LUCKNOW. PATNA. THIRUVANANTHAPURAM.