

इंटरनेट

मानक

### Disclosure to Promote the Right To Information

Whereas the Parliament of India has set out to provide a practical regime of right to information for citizens to secure access to information under the control of public authorities, in order to promote transparency and accountability in the working of every public authority, and whereas the attached publication of the Bureau of Indian Standards is of particular interest to the public, particularly disadvantaged communities and those engaged in the pursuit of education and knowledge, the attached public safety standard is made available to promote the timely dissemination of this information in an accurate manner to the public.

“जानने का अधिकार, जीने का अधिकार”

Mazdoor Kisan Shakti Sangathan

“The Right to Information, The Right to Live”

“पुराने को छोड़ नये के तरफ”

Jawaharlal Nehru

“Step Out From the Old to the New”

IS 12976 (1990): Solar water heating systems- Code of practice [MED 4: Non-Conventional Energy Sources]



“ज्ञान से एक नये भारत का निर्माण”

Satyanarayan Gangaram Pitroda

“Invent a New India Using Knowledge”



“ज्ञान एक ऐसा खजाना है जो कभी चुराया नहीं जा सकता है”

Bhartrhari—Nitiśatakam

“Knowledge is such a treasure which cannot be stolen”



BLANK PAGE



भारतीय मानक

सौर जल तापन प्रणाली – रीति संहिता

*Indian Standard*

**SOLAR WATER HEATING SYSTEMS —  
CODE OF PRACTICE**

( First Reprint SEPTEMBER 1993 )

UDC 696.48-67:006.76

© BIS 1991

**BUREAU OF INDIAN STANDARDS**  
MANAK BHAVAN, 9 BAHADUR SHAH ZAFAR MARG  
NEW DELHI 110002

**FOREWORD**

**This Indian Standard was adopted by the Bureau of Indian Standards on 22 March 1990, after the draft finalized by the Solar Energy Sectional Committee had been approved by the Heavy Mechanical Engineering Division Council.**

**A solar water heating system consists mainly of three components, namely solar collector, storage tank and connecting pipes. Other components which may be required are heat exchangers, circulating pumps and measuring instruments.**

**This standard gives general guidelines for solar water heating systems.**

## Indian Standard

# SOLAR WATER HEATING SYSTEMS — CODE OF PRACTICE

### 1 SCOPE

This standard gives general characteristics of all types of solar water heating systems with flat plate or tubular collectors and their performance evaluation methods.

1.1 This standard provides the principles of corrosion, anti-freeze and overheating protection of the system.

### 2 REFERENCES

2.1 The following Indian Standards are necessary adjuncts to this standard:

IS No.	Title
12933 ( Part 1 ) : 1990	Solar flat plate collector : Part 1 General requirements
12933 ( Part 2 ) : 1990	Solar flat plate collector : Part 2 Components
12933 ( Part 3 ) : 1990	Solar flat plate collector : Part 3 Measuring instruments
12933 ( Part 4 ) : 1990	Solar flat plate collector : Part 4 Performance requirements and accepted criteria
12933 ( Part 5 ) : 1990	Solar flat plate collector : Part 5 Test methods

### 3 CLASSIFICATION

3.1 The solar water heating systems are classified by the mode of fluid flow through them.

### 3.2 Passive System

This system works without the aid of pump and instrumentation.

#### 3.2.1 Thermosyphon System

This system is shown in Fig. 1A and 1B. It works on the principle of natural convection. The water from the bottom of the tank enters the solar collector and gets heated. This heated water becomes less dense and rise again to the tank. This continues till the temperature differential at the bottom and top remain. In this system since the density difference is the driving force:

- a) Pipe friction losses should be low,
- b) Pipe should have minimum length with larger diameter (above 25 mm) with minimum fittings,
- c) To prevent the reverse thermosyphoning during night, the top of the collector header should be more than 50 cm below the bottom of the storage tank,
- d) For very cold climates a heat exchanger with water, mixed with anti-freeze liquid is recommended, and
- e) The heat exchanger is also recommended when water is very hard.

#### 3.2.2 Built-in Storage Systems

These systems are shown in Fig 2A. The main features of this system are:

- a) The collector and storage units are integrated into one, reducing the space requirements,

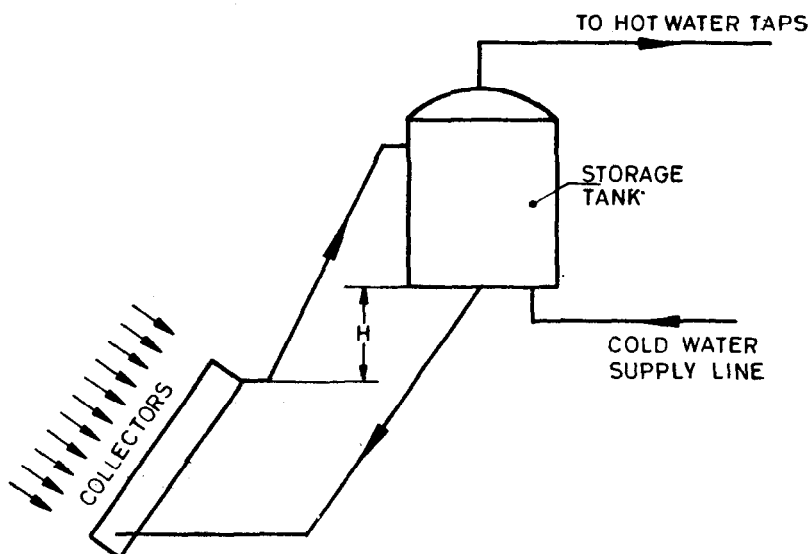

FIG. 1A THERMOSYPHON SWH SYSTEM ( OPEN LOOP )

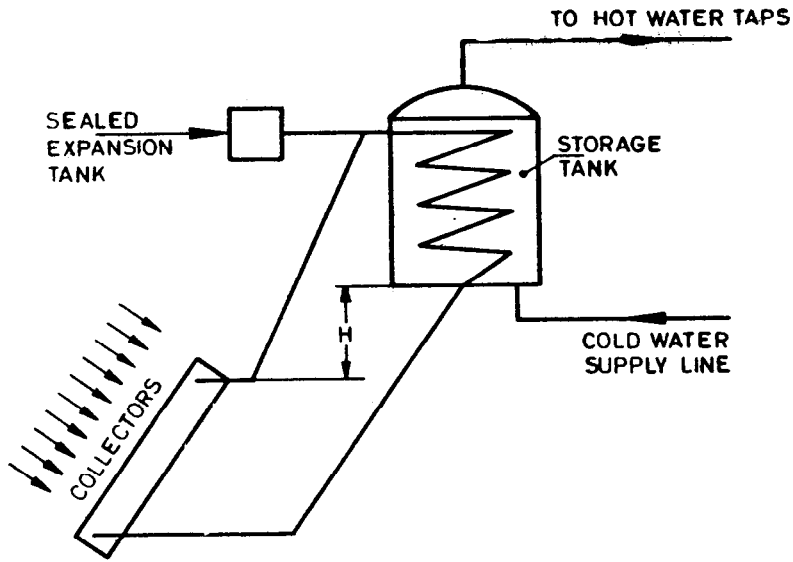

FIG. 1B THERMOSYPHON SWH SYSTEM ( CLOSED LOOP )

- b) The cylindrical unit is housed in a properly insulated parabolic or rectangular case with double glazings,
- c) On the inner side of the casing highly reflective foil may be placed to direct more radiation on the unit,
- d) The cylindrical metallic absorber/storage unit is covered with selective coatings which maximizes absorption during day and minimizes the heat loss in off sunshine period.

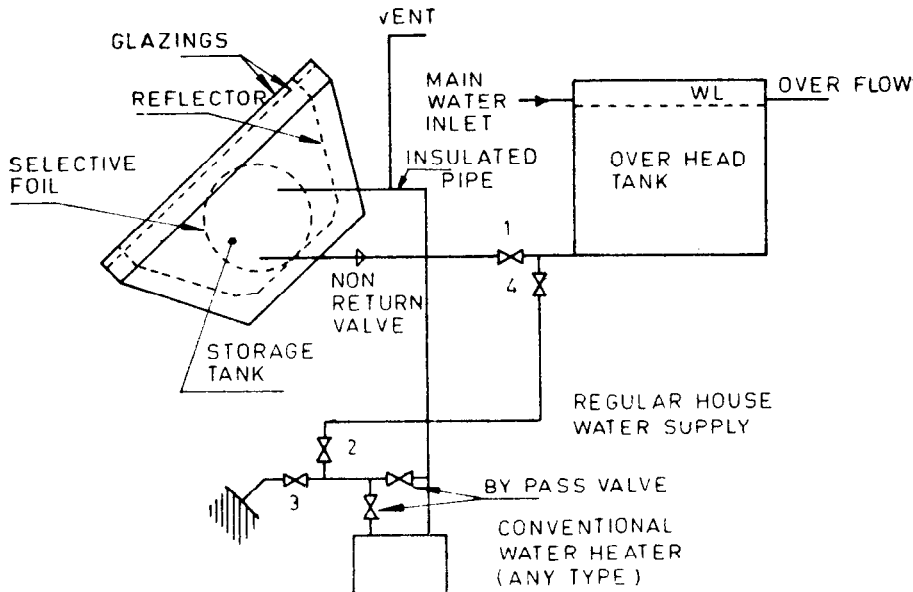

FIG. 2A SCHEMATICS OF BUILT-IN STORAGE SWH ( SINGLE CYLINDER )

The cylindrical unit may be replaced by number of small cylinders as shown in Fig 2B.

**3.3.1 Closed Loop Systems**

These systems are shown in Fig. 3A. These

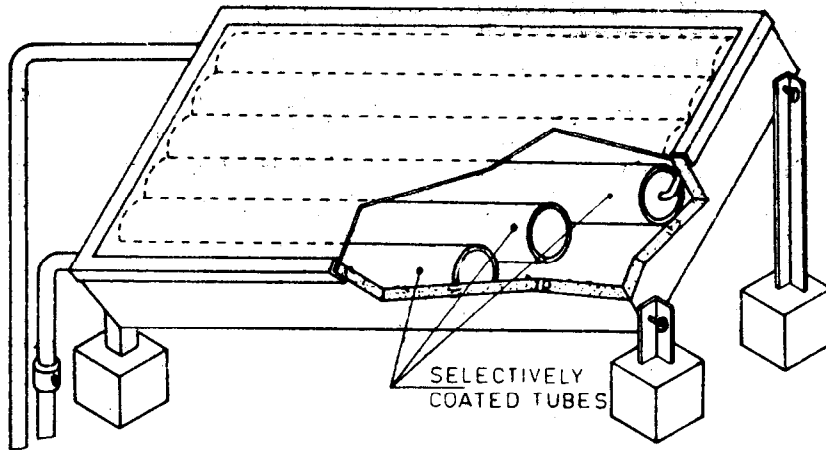

FIG. 2B SCHEMATICS OF BUILT-IN STORAGE SWH ( 6 CYLINDER )

**3.3 Active Systems**

In this system, the working fluid is transported by forced circulation which involves use of pumps and controls. The major components of these types of systems are collector, storage tank, circulation pumps and differential thermostat. In addition a complete system requires items such as auxiliary heating unit, heat exchangers and expansion tanks, valves and gauges.

systems use a heat transfer fluid and heat exchanger to heat service water. In very cold climate, this system is recommended to protect the freezing. It is also used where water is too hard or acidic which may cause scale deposits that clog or corrode the fluid passage. The closed loop systems require an expansion tank to accommodate pressure changes.

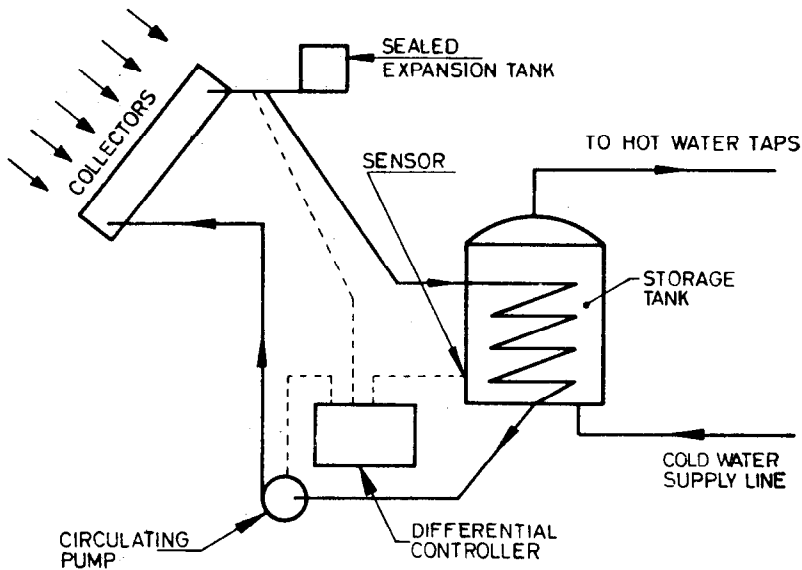

FIG. 3A ACTIVE SWH SYSTEM ( CLOSED LOOP )



**3.3.2 Open Loop Systems**

These systems are shown in Fig. 3B. In open loop system, service water is heated directly through the collector. Being in contact with the outside air, this system is more susceptible to corrosion. Therefore, adequate precaution for its prevention are necessary in this system.

**4 COMPONENTS OF SOLAR WATER HEATING SYSTEM**

The major components of solar water heating system are given below.

- $U_L$  is the solar collector heat-transfer loss co-efficient in  $Wm^{-2}C$ ,
- $m$  is the mass flow rate of the transfer fluid in kg/s,
- $C_P$  specific heat of the transfer fluid in  $J/kg^{\circ}C$ ,
- $A$  is the collector area in  $m^2$ , and
- $C_{min}$  smaller of the two fluid capacitance rates in the heat exchanger.

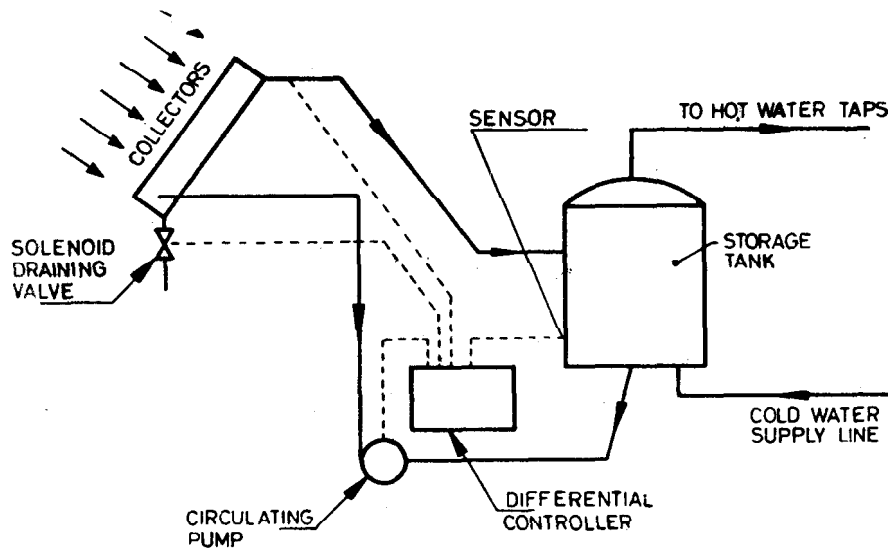

FIG. 3B ACTIVE SWH SYSTEM ( OPEN LOOP )

**4.1 Solar Collector**

The part of the system which collects the energy. They may be of many types such as evacuated tube, concentrating, trough or flat plate depending upon the temperature required and climatic conditions. Most widely used collectors are flat plate type in accordance with IS 12933 ( Part 1 to 5 ).

**4.1.1 Collector Heat Exchanger Efficiency Factor**

When a heat exchanger is used in the system, the collector heat exchanger efficiency factor ' $F_R$ ' shall be substituted for  $F_R$  to calculate the combined performance of collector and heat

exchanger. The ratio  $\frac{F_R'}{F_R}$  is the correction

factor, varying from 0 to 1.  $\frac{F_R'}{F_R}$  may be

determined as a function of collector's performance, heat exchanger flow rate and heat exchanger effectiveness as:

$$\frac{F_R'}{F_R} = \left[ 1 + \frac{F_R U_L}{m C_P} \frac{A \cdot m C_P}{E \cdot C_{min}^{-1}} \right]^{-1}$$

where

$F_R$  is the solar heat removal factor, dimensionless,

**4.1.2 Collector Orientation**

Solar collector should always be kept facing due south at an inclination so that it receives maximum radiation. This inclination depends on the utility pattern of hot water. The optimum value for inclination of the collector with the horizontal is latitude for year round performance and latitude + 10° to + 15° for water months and latitude - 10° to - 15° for summer months. When a row of collectors are mounted, to avoid shading, the minimum distance between the two collectors ( $D$ ) is given by:

$$D = \frac{\sin \theta \times \text{collector length}}{\tan (66.5^{\circ} - \text{latitude})}$$

where  $\theta$  is the collector tilt with the horizontal as shown in Fig. 4.

**4.1.3 Collector Combination ( Arrays )**

A number of collectors are connected in series/ parallel combination in large systems. The type of combination and number of collectors in series will depend upon the flow rate, pressure drop in the system and the temperature desired. Also, the performance characteristics of the collector should be known. Some possible combinations are known in Fig. 5.

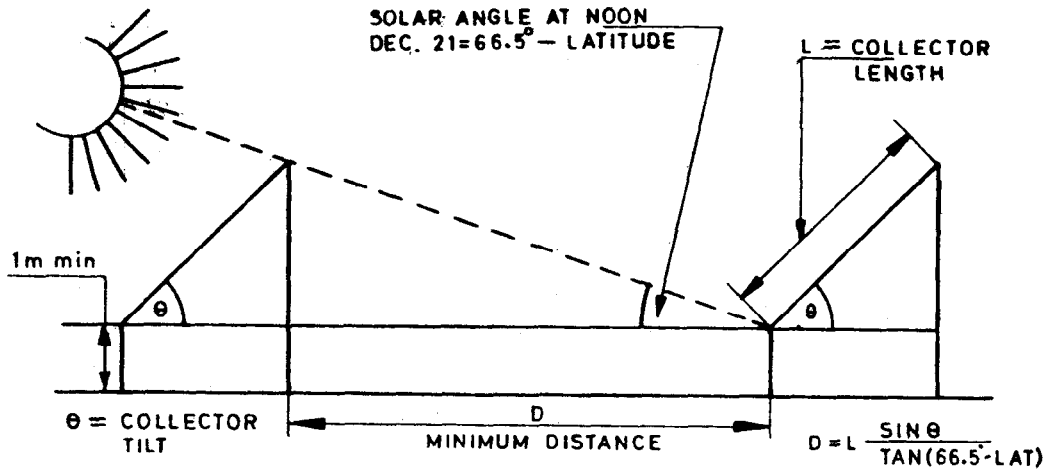

FIG. 4 MINIMUM DISTANCE REQUIRED BETWEEN ROWS OF COLLECTORS

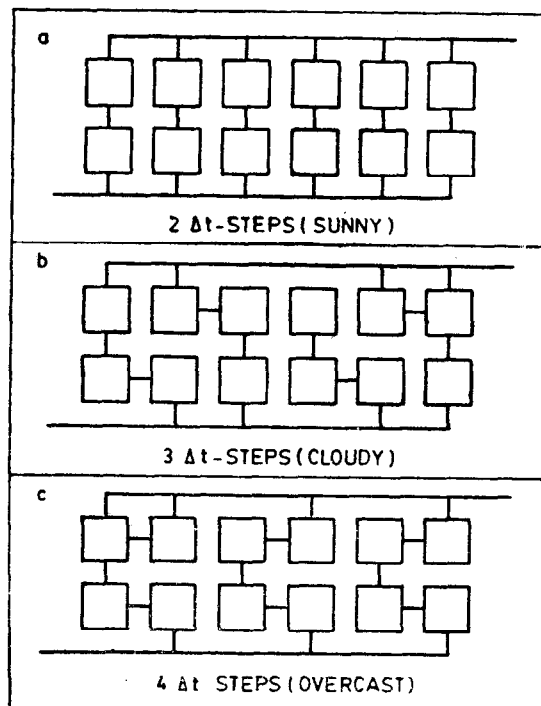
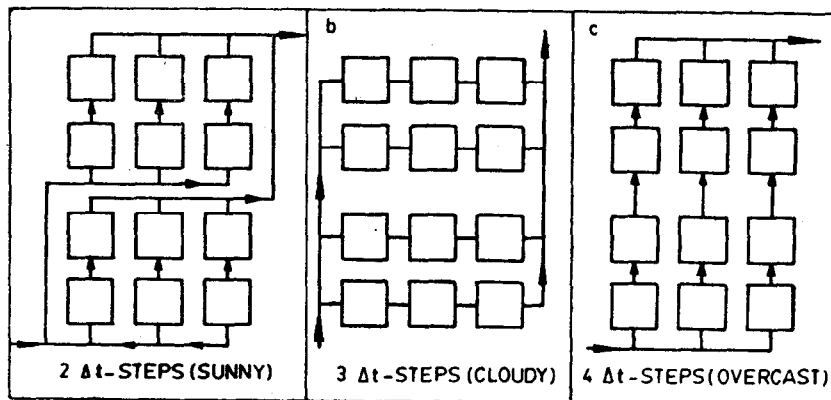

FIG. 5 ALTERNATIVE ARRANGEMENTS FOR COLLECTOR COMBINATIONS (6 x 2 SYSTEM),

## 4.2 Storage Tanks

The thermal energy storage in solar water heating system is in one or two tanks. It should be such sized as to store 1.5 to 2 times the average daily hot water usage. The tank capacities are generally chosen between 40 to 100 litres  $m^{-2}$  of collector area.

**4.2.1** The material used for tank may be copper, steel, aluminium or concrete. But the inner side of the tank must be of a material which does not contaminate water (if direct system), is non-corrosive, and stable at maximum operating temperature.

**4.2.2** The tank outlet to the collector should be about 10 cm above the tank bottom to prevent scale deposits from being drawn into the collector. The hot water outlet pipe should be at the top end to increase stratification in thermosyphon system.

**4.2.3** The exterior of the tank must be properly insulated so that the hot water temperature does not decrease by more than  $8^{\circ}C$  in about 16 hours time. Generally thickness of 7-10 cm of fibreglass or cork insulation is provided.

## 4.3 Expansion Tank

The volume change of fluid in closed loop system must be accommodated by an external expansion tank. The sizing of this tank must account for the variation of density with temperature for the fluid used in loop. Generally expansion tank is  $\frac{1}{3}$  to  $\frac{1}{2}$  of the total volume of storage tank. The maximum operating temperature of these tanks should be taken as equal to collector stagnation temperature.

## 4.4 Heat Exchangers

Heat exchangers are used for protection against freezing, scaling and corrosion. Heat exchanger selection considers its effectiveness, pressure drop, flow rate and total protection of the potable water from contamination if the working fluid is toxic. It must be properly insulated and thermally compatible with system design parameters. Its overall heat transfer co-efficient and heat transfer area should be large. The exchanger effectiveness is given as:

$$E_{hx} = \frac{Q_{hx}}{(mC_p)_{min}} (T_{hi} - T_{ci})$$

where  $Q_{hx}$  is amount of heat transferred,  $(mC_p)_{min}$  is the minimum of the capacitance rate of the two fluids,  $T_{hi}$  is the hot stream inlet temperature and  $T_{ci}$  is cold stream inlet temperature. Generally a heat exchanger effectiveness of 0.7 to 0.8 is recommended. The counter flow heat exchangers have larger effectiveness compared to immersed coil.

## 4.5 Heat Transfer Fluid

In direct or open loop systems, water is most common fluid. The liquid to be used in solar

systems should have high specific heat, low viscosity, particularly at low temperatures, low vapour pressure/high boiling point, relatively high surface tension (to avoid leaks), high density and high thermal conductivity to provide efficient heat transfer over a wide range of temperatures.

## 4.6 Pumps

The selection of pump must consider the head and discharge requirements and the operating temperature and pressure losses. In solar water heating system usually a centrifugal pump is recommended. When oil or hydrocarbon (high microns liquids) is used in the loop, positive displacement pump should be used with a relief valve on the pump outlet.

## 4.7 System Piping and Fittings

The material of the pipe must be compatible with the working fluid, its velocity of flow and with the material of riser tubes in the collector.

**4.7.1** The collector array and piping should be properly insulated to avoid heat loss. After insulation they are covered by aluminium foil to avoid damage to insulation.

## 4.8 Valves and Gauges

The valves and its seals should be such that it is able to bear maximum temperature and compatible with fluid used. These valves must be placed properly such that its function cannot be deactivated by anything.

## 4.9 Control Systems

In an active solar water heating system, control systems are used to switch on a circulation pump whenever energy gain is possible through solar collectors. Otherwise, it automatically switches off the pump. A differential thermostat is recommended as it optimizes the energy gain for the system. A fixed point controller is used when the system is employed for process applications.

## 5 AUXILIARY HEATING

In hot weather or tropical counter, auxiliary heating system is not required, but in cold climate low solar radiation regions, an auxiliary heating unit run by electricity, fuel or gas is needed.

## 6 SIZING AND LOAD CONSIDERATION

The size of the solar water heating system depend on the local weather conditions, the daily demand and load pattern.

## 7 SYSTEM PERFORMANCE EVALUATION METHOD

### 7.1 'f' Chart Method

The 'f' chart method of estimating the performance of a system is applicable to active system designs shown in Fig. 6. This method requires only the monthly average meteorological data for the estimation of long term thermal perform-

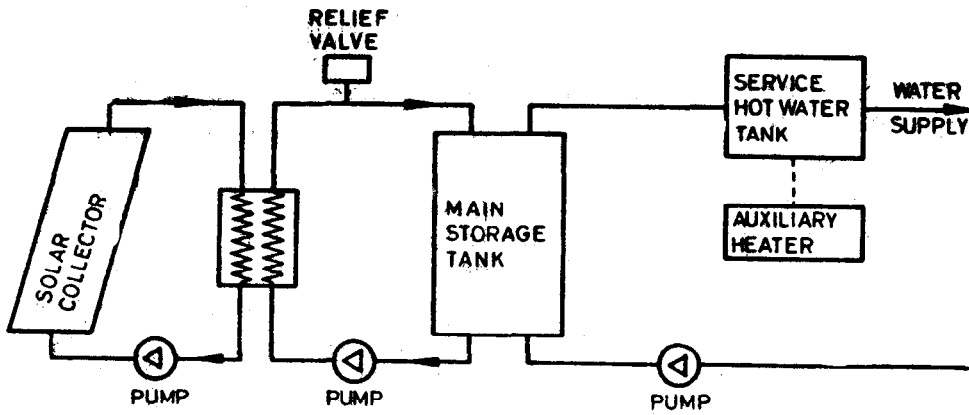

FIG. 6 SOLAR HEATING SYSTEM

ance of the system as a function of major system design parameters. The solar heating fraction 'f' is a function of dimensionless groups which relate the system properties and weather data for a month to the monthly heating requirements. The several dimensionless parameters are grouped into solar parameters 'Y' and loss parameters 'X'. The 'f' chart method is recommended for the following design parameters:

- Collector flow rate : 0.015 l/s
- Collector heat exchanger correction factor :  $F_R'/F_R$  0.9
- Storage capacity : 50 to 100 l/m<sup>2</sup>
- Load heat exchanger : 1
- Collector slope :  $L \pm 10^\circ\text{C}$  due south
- Preheat tank storage : 1.5 to 2 times capacity of conventional water heater

The two dimensionless parameters X and Y are calculated as:

$$X = \frac{A \cdot b \cdot (100 - T_a) \cdot n \cdot 24 \cdot C_2 \cdot C_3 \cdot C_4}{L \cdot 1000}$$

$$Y = \frac{\text{Absorbed solar energy}}{\text{Heating load}} = \frac{A \cdot a \cdot H \cdot n \cdot C_1 \cdot C_2}{L}$$

where

- n is the number of days in the month
- H is daily average radiation on the collector kWhm<sup>-2</sup>
- T<sub>a</sub> is the average air temperature for the month °C
- L is the monthly heating load given by  $L = V \cdot \sigma \cdot C_p \cdot (T_w - T_a) \cdot n$
- V is the volume of hot water required per day
- σ is the density of water
- C<sub>p</sub> is the specific heat of water
- T<sub>w</sub> is the minimum acceptable temperature of water

a is the no loss coefficient (first constant)

$a = F_R(\tau_a)$  — determined by collector performance test in accordance with IS 12933 (Parts 1 to 5) : 1990

b is the loss co-efficient (second constant)

$b = F_R U_L$  — determined by collector performance test in accordance with IS 12933 (Parts 1 to 5) : 1990

C<sub>1</sub> is the correction term for glazing

- = 0.85 for single glass
- = 0.75 for double glass

C<sub>2</sub> is the correction term for heat exchangers in the circuit

- = 1 for direct system
- = 0.97 for counterflow heat exchangers
- = 0.95 for an average heat exchanger
- = 0.90 (lowest value)

C<sub>3</sub> is the correction term if the storage/collector ratio is other than 75 l/m<sup>2</sup> collector area (between the limits of 37.5 and 300 l/m<sup>2</sup>)

$$C_3 = \frac{[\text{Storage/Collector Ratio}]^{-0.25}}{75}$$

C<sub>4</sub> is the correction term for the system given by

$$C_4 = \frac{11.6 + (1.18 T_w) + (3.86 T_c) - (2.32 T_a)}{100 - T_a}$$

Where T<sub>c</sub> is the cold water supply temperature after finding the values of 'X' and 'Y', the solar fraction 'f' is calculated by:

$$f = 1.029 Y - 0.065 Y^2 - 0.245 Y^3 + 0.0018 X^2 + 0.0215 Y^3$$

for  $0 < Y < 3$  ;  $0 < X < 18$

A sample calculation for performance evaluation is given in Annex A.

## 8 SYSTEM PROTECTION

### 8.1 Freezing

Since freezing in winter may altogether damage the system, freeze protection is important.

#### 8.1.1 Antifreeze System

In closed loop systems, an antifreeze material is added to the loop and heat exchanger is employed to heat potable water. The concentration of antifreeze material depend on severity of freeze conditions expected.

#### 8.1.2 Drain Down System

One method of freeze protection is to drain the collector when a freezing condition is sensed, that is, when temperature in the collector falls below 4°C. An automatic air vent is located at highest post of the system. When the collector array is filling, air vents out and vents close. When the pump stops either freeze conditions or due to power failure, the vents get open under atmospheric pressure and collector array drains water into storage tank ( Fig. 7 ).

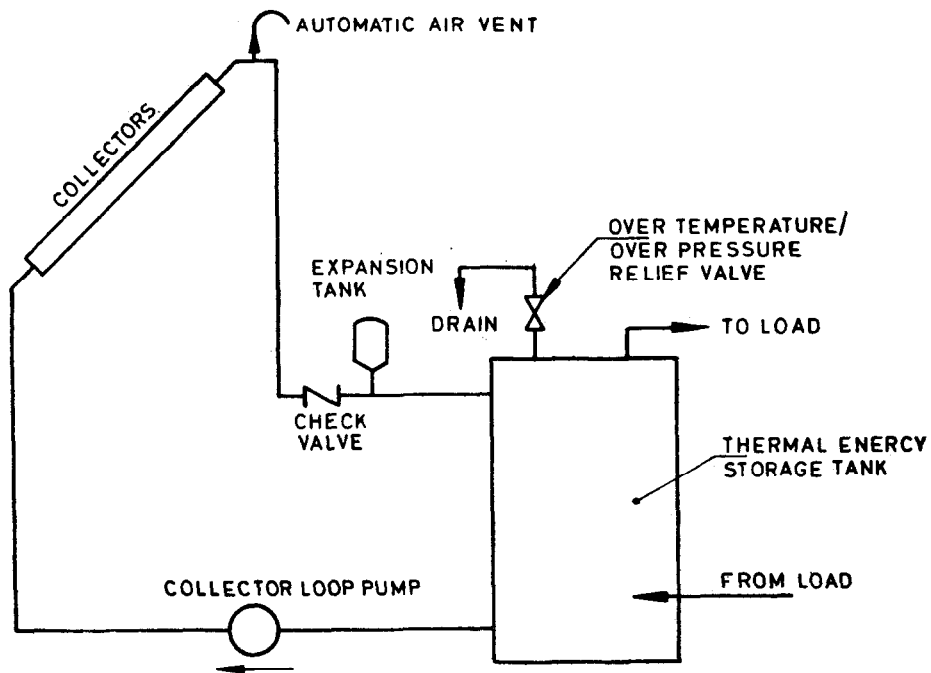

FIG. 7 AIR ASSISTED DRAIN-DOWN SYSTEM SCHEMATIC

### 8.2 Over Heating

During periods of high radiation and low hot water demand, over heating may occur in the collector or storage tanks. Protection against overheating must be considered for all portions of the solar water heating system. Liquid expansion or excessive pressure may burst piping or storage tanks. Steam or other gases within a system may restrict liquid flow, making the system inoperable. In indirect systems where antifreeze fluids such as glycol are used, over-temperature protection is needed to limit the fluid degradation at higher temperature closing collector stagnation.

The most common method of overheat protection is to stop circulation in the collector loop until the storage temperature decreases or using a heat exchanger as means of heat rejection.

## 9 CORROSION PREVENTION

Most components of the system are metals and use water or fluid for heating it. It is, therefore, essential to prevent corrosion of the system components to enhance its life.

### 9.1 Types of Corrosion and Prevention

Corrosion in metals in the system may occur both internally within the fluid passages of the collector and system pipe work and externally on the surfaces of the collector box and absorber plate.

#### 9.1.1 Oxidation Corrosion

Oxygen dissolved in heat transfer fluid oxidize the metal and cause corrosion. This is easily prevented in closed loop system where the fluid is not in direct contact with air. In drain drum

system, air enters the system through vents and may cause corrosion.

#### 9.1.2 Bimetallic or Galvanic Corrosion

This corrosion occurs between two dissimilar metals when in contact with an electrolyte. In such cases dimetallic insulating couplings like PTFE tape in threaded joints should be used specially when water is the fluid and two dissimilar metals are joined. This corrosion may also be prevented by putting a sacrificial anode of higher electromotive potential than any other metal in the system like in copper collector with

steel tubes, magnesium as anode is put which dissolves, protecting both the metals.

### 9.1.3 Ion Exchange Pitting Corrosion

It occurs when the fluid carry heavy metals ions, deposit them on another metal in the presence of an electrolyte. It is a localized attack that may result in penetration and subsequent leakage. Heavy metal ions may be present in the fluid naturally or may appear due to corrosion in other part of the system. To suppress the ion exchange between the metal and ion, corrosion inhibitors be added in transport fluid. These ions present in the fluid alter the pH. Therefore pH should be constantly monitored to retain its neutrality.

### 9.1.4 Crevice Corrosion

It is similar to pitting corrosion and results in a rapid metal loss inside a crevice. The crevice formation may be the result of bad fittings, leaky gaskets, scale deposits, blockages or unusual flow patterns. The fluid passage should not be blocked and in system some inhibitors should be added.

### 9.1.5 Scaling

Water contains variety of metallic and non-metallic impurities such as calcium and magnesium compounds. These impurities precipitate as scales under certain influences. To avoid scaling, deionized/neutral pH water should be used or some inhibitors should be added.

## 10 SYSTEM INSTALLATION

Proper installation of the system is most important for its proper functioning and maintenance.

### 10.1 Collector Mounting

Solar collectors are usually mounted on the ground on flat or pitched roofs. A roof location necessitates the penetration of the building envelope for mounting hardware, piping control and wiring.

When mounted on racks the collector array becomes more vulnerable to wind gusts as the angle of the moment increases. Collectors may be uplifted by wind striking the undersides. This wind load, in addition to the equivalent roof area should be determined according to accepted engineering procedures.

### 10.2 Storage Tank

Storage tank should be placed as near to the collector as possible to reduce piping length and heat losses. The tank should be properly insulated. After insulation it may be covered by reflective aluminium foil. In an active system the tank may be placed inside the building.

### 10.3 Piping and Fitting

The piping length should be as small as possible with minimum joints and elbows. They must be leak proof. Pipe bends should be preferred to elbows since they have less pressure drop. The pipe must be properly insulated and made weather proof by covering with aluminium foils.

**10.3.1** The slope of the pipe should be such that proper draining of the collector array is ensured. There should be no inverted U shape loop to avoid air traps.

**10.3.2** In the system all valves must be accessible for rapid turn-off if emergency shut down is required. The wiring used to connect sensors to the control unit must be impervious to moisture and should be placed away from power lines to avoid electromagnetic interference.

## ANNEX A

( Clause 7.1 )

### SAMPLE CALCULATION FOR SYSTEM SIZING

The procedure is best illustrated by an example. It is required to have a SWH system to provide 50 000 l/d at 55°C at Bombay ( Lat 19.12 ). The collector is of area 1100 m<sup>2</sup> and is doubly glazed with direct system. The collector constant are:

$$F_R (\tau_a) = a = .75$$

$$F_R U_L = b = 3.8$$

The storage/collector ratio is 40 lit/m<sup>2</sup>. The tank is cylindrical with diameter and length each being 4 m, insulated by 100 mm polyurethane insulation ( thermal conductivity 0.28 w/m<sup>2</sup>k).

### CALCULATIONS

Since  $a = .75$

$$b = 3.8$$

$$C_1 = .85 \text{ ( for double glazing )}$$

$$C_2 = 1 \text{ ( for direct system )}$$

$$C_3 = \left( \frac{40}{75} \right)^{-0.25} = 1.17$$

$$C_4 = \frac{11.6 + (1.18 T_w) + (3.86 \cdot T_c) - 2.32 T_a}{(100 - T_a)}$$

Now these values and load is calculated for the month and put in the table as shown in Table A1. col 1 is the month and col 2 is the average daily radiation and col 3 is average daily ambient temperature, col 4 is the average cold water temperature and col 5 is number of days in a month. Now daily load is calculated by the expression:

$$L = V \cdot \rho \cdot C_p (T_w - T_a) \cdot n$$

$$= 1.16 \times 50\,000 \times 31 \times (55 - 26.6)$$

After this the daily average load is entered in col 6. Then the calculation for X and Y made and 'f' compared are put in col 7, 8 and 9 respectively. Finally annual solar fraction is computed.

Table A1 'f' Chart Tabulations

Month	$H$	$t_a$	$t_c$	$n$	Daily Load $L$ (KWH)	$C_A$	$X$	$Y$	$f$	Monthly Load $mC(T_i - T_a)$	Solar Contri- bution
1	4.104	23.4	26.6	31	1 663.23	2.08	11.2	3.0	0.960	51 560.0	49 497.6
2	6.929	24.6	27.9	28	1 587.23	2.14	11.9	3.1	0.957	44 442.24	42 531.4
3	6.803	26.4	29.2	31	1 510.87	2.20	12.6	3.3	0.967	4 6837.0	45 291.4
4	6.662	28.3	30.7	30	1 422.92	2.28	13.5	3.3	0.951	4 2687.7	40 596.0
5	6.499	29.7	31.5	31	1 375.8	2.32	13.9	2.2	0.751	4 2649.8	32 030.0
6	4.716	28.7	29.7	30	1 480.74	2.22	12.6	1.7	0.614	4 4422.2	27 275.2
7	3.805	27.3	27.9	31	1 586.86	2.13	11.5	1.7	0.637	49 161.5	31 315.9
8	3.805	26.8	27.4	31	1 615.09	2.11	11.2	2.1	0.777	50 067.9	38 902.8
9	4.829	26.9	27.9	30	1 586.05	2.13	11.2	2.1	0.777	47 581.6	36 970.9
10	6.042	27.6	29.9	31	1 469.70	2.24	12.9	2.9	0.909	45 560.7	41 414.7
11	6.830	26.6	30.0	30	1 464.37	2.24	13.2	3.3	0.956	43 931.2	41 998.2
12	6.942	24.7	25.4	31	1 732.17	2.01	10.0	2.9	0.962	53 697.2	51 656.7

Total 562 599.2 479 480.0

Month — Month under consideration.

$H$  — Total hourly solar radiation for Bombay latitude 19°12', longitude 72°85' tilt factor 22.50

$t_a$  — Temperature of ambient air in °C.

$t_c$  — Temperature of cold water in °C.

Load — in kWh

$n$  — Number of days in a month

$f$  — Solar fraction

$$\text{Annual Solar Fraction} = \frac{\sum_{n=1}^{n=12} \text{Solar contribution}}{\sum_{n=1}^{n=12} \text{Monthly load}}$$

$$= \frac{479\,480.8}{562\,599.2}$$

$$= 0.852\,26$$

### **Standard Mark**

The use of the Standard Mark is governed by the provisions of the *Bureau of Indian Standards Act, 1986* and the Rules and Regulations made thereunder. The Standard Mark on products covered by an Indian Standard conveys the assurance that they have been produced to comply with the requirements of that standard under a well defined system of inspection, testing and quality control which is devised and supervised by BIS and operated by the producer. Standard marked products are also continuously checked by BIS for conformity to that standard as a further safeguard. Details of conditions under which a licence for the use of the Standard Mark may be granted to manufacturers or producers may be obtained from the Bureau of Indian Standards.



## Bureau of Indian Standards

BIS is a statutory institution established under the *Bureau of Indian Standards Act, 1986* to promote harmonious development of the activities of standardization, marking and quality certification of goods and attending to connected matters in the country.

### Copyright

BIS has the copyright of all its publications. No part of these publications may be reproduced in any form without the prior permission in writing of BIS. This does not preclude the free use, in the course of implementing the standard, of necessary details, such as symbols and sizes, type or grade designations. Enquiries relating to copyright be addressed to the Director (Publications), BIS.

### Revision of Indian Standards

Indian Standards are reviewed periodically and revised, when necessary and amendments, if any, are issued from time to time. Users of Indian Standards should ascertain that they are in possession of the latest amendments or edition. Comments on this Indian Standard may be sent to BIS giving the following reference:

Doc : No. HMD 4 ( 5008 )

### Amendments Issued Since Publication

Amend No.	Date of Issue	Text Affected

## BUREAU OF INDIAN STANDARDS

### Headquarters:

Manak Bhavan, 9 Bahadur Shah Zafar Marg, New Delhi 110002  
Telephones : 331 01 31, 331 13 75

Telegrams : Manaksanstha  
( Common to all Offices )

### Regional Offices :

	Telephone
Central : Manak Bhavan, 9 Bahadur Shah Zafar Marg NEW DELHI 110002	{ 331 01 31 331 13 75
Eastern : 1/14 C. I. T. Scheme VII M, V. I. P. Road, Maniktola CALCUTTA 700054	{ 37 84 99, 37 85 61 37 86 26, 37 86 62
Northern : SCO 445-446, Sector 35-C, CHANDIGARH 160036	{ 53 38 43, 53 16 40 53 23 84
Southern : C. I. T. Campus, IV Cross Road, MADRAS 600113	{ 235 02 16, 235 04 42, 235 15 19, 235 23 15
Western : Manakalaya, E9 MIDC, Marol, Andheri ( East ) BOMBAY 400093	{ 632 92 95, 632 78 58. 632 78 91, 632 78 92

Branches : AHMADABAD, BANGALORE, BHOPAL, BHUBANESHWAR, COIMBATORE  
FARIDABAD, GHAZIABAD, GUWAHATI, HYDERABAD, JAIPUR, KANPUR  
LUCKNOW, PATNA, THIRUVANANTHAPURAM.