

इंटरनेट

मानक



Disclosure to Promote the Right To Information

Whereas the Parliament of India has set out to provide a practical regime of right to information for citizens to secure access to information under the control of public authorities, in order to promote transparency and accountability in the working of every public authority, and whereas the attached publication of the Bureau of Indian Standards is of particular interest to the public, particularly disadvantaged communities and those engaged in the pursuit of education and knowledge, the attached public safety standard is made available to promote the timely dissemination of this information in an accurate manner to the public.

“जानने का अधिकार, जीने का अधिकार”

Mazdoor Kisan Shakti Sangathan

“The Right to Information, The Right to Live”

“पुराने को छोड़ नये के तरफ”

Jawaharlal Nehru

“Step Out From the Old to the New”

IS 8213 (2000): Agricultural Tractor Trailer [FAD 11:
Agricultural Tractors and Power Tillers]



“ज्ञान से एक नये भारत का निर्माण”

Satyanarayan Gangaram Pitroda

“Invent a New India Using Knowledge”



“ज्ञान एक ऐसा खजाना है जो कभी चुराया नहीं जा सकता है”

Bhartrhari—Nitiśatakam

“Knowledge is such a treasure which cannot be stolen”

BLANK PAGE



भारतीय मानक
कृषि ट्रैक्टर ट्रेलर — विशिष्टि
(तीसरा पुनरीक्षण)

Indian Standard
AGRICULTURAL TRACTOR TRAILER —
SPECIFICATION
(*Third Revision*)

ICS 65.060.10

© BIS 2000

BUREAU OF INDIAN STANDARDS
MANAK BHAVAN, 9 BAHADUR SHAH ZAFAR MARG
NEW DELHI 110002

FOREWORD

This Indian Standard (Third Revision) was adopted by the Bureau of Indian Standards, after the draft finalized by the Farm Implements and Machinery Sectional Committee had been approved by the Food and Agriculture Division Council.

Tractor operated trailers are used for transport of farm produce. This standard has been prepared for the guidance of manufacturers and purchasers in the production and selection of trailers of proper quality.

This standard was first published in 1976 and subsequently revised in 1983 and 1987. This revision has been taken up in view of the following:

- a) To enlarge the scope of standard by incorporating requirements of IS 8463 : 1987 'Axle assembly for agricultural tractor trailer (*first revision*)'.
- b) To incorporate the lighting requirements in accordance with *Central Motor Vehicles Act, 1988* and Safety Standard (SS-15) of Automotive Research Association of India.
- c) To update the standard.

The figures given in the standard are intended to serve only as illustrations and should not be considered as suggestive of any standard design.

In preparation of this standard due attention has been given to *Central Motor Vehicles Acts, 1988*. However, it is subjects to the restrictions imposed thereunder as amended from time to time.

The dimensions of the trailer and its accessories shall not, in any way, infringe the rules and regulations of the Local Transport Authority in force from time to time.

For the purpose of deciding whether a particular requirement of this standard is complied with the final value, observed or calculated, expressing the result of a test or analysis, shall be rounded off in accordance with IS 2 : 1960 'Rules for rounding off numerical values (*revised*)'. The number of significant places retained in the rounded off value should be the same as that of the specified value in this standard.

Indian Standard

AGRICULTURAL TRACTOR TRAILER — SPECIFICATION (*Third Revision*)

1 SCOPE

1.1 This standard specifies material, constructional and other requirements of agricultural trailer fitted with pneumatic tyres and operated by agricultural tractor.

1.1.1 This standard covers requirements of balanced trailers up to 10 tonnes and semi-trailers up to 5 tonnes capacity.

2 REFERENCES

The following Indian Standards contain provisions which through reference in this text, constitute provisions of this standard. At the time of publication, the editions indicated were valid. All standards are subject to revision and parties to agreements based on this standard are encouraged to investigate the possibility of applying the most recent editions of the standards indicated below:

<i>IS No.</i>	<i>Title</i>
210 : 1993	Grey iron castings (<i>fourth revision</i>)
549 : 1974	Split pins (<i>second revision</i>)
816 : 1969	Code of practice for use of metal arc welding for general construction in mild steel (<i>first revision</i>)
1030 : 1998	Carbon steel castings for general engineering purposes (<i>fifth revision</i>)
1079 : 1994	Hot rolled carbon steel sheets and strips (<i>fifth revision</i>)
1135 : 1995	Springs leaf springs assembly for automobiles (<i>fifth revision</i>)
1875 : 1992	Carbon steel billets, blooms, slabs and bars for forgings (<i>fifth revision</i>)
2062 : 1992	Steel for general structural purposes (<i>fourth revision</i>)
2179 : 1979	Converted timber for lorry bodies (<i>first revision</i>)
2232 : 1967	Slotted and castle nuts (<i>first revision</i>)
3431 : 1982	Steel for manufacture of volute, vehicle and laminated springs for automatic suspension (<i>second revision</i>)
3628 : 1966	Sidelights, tail-lights, parking lights, stop lights and direction indicators for automobile use
4060 : 1994	Flashers for direction indicators for automobiles (<i>first revision</i>)

4370 : 1967	Code of practice for the use of lighting and signalling devices on cars and commercial vehicles
5129 (Part 1) : 1987	Rotary shaft radial lip type oil seal units: Part 1 Dimensions (<i>second revision</i>)
7461 (Part 2) : 1992	General plan of boundary dimensions for tapered roller bearings: Part 2 Double row bearings (<i>second revision</i>)
9821 : 1981	Glossary of terms related to farm transport equipment
9942 : 1981	T-Sign plate for trailers
10694 (Part 6) : 1988	Automotive vehicles — Rims — General: Part 6 Requirements for rims for agricultural tractors, power tillers and implements (<i>first revision</i>)
11270 : 1985	Ring type hitches for agricultural trailers.
12239 (Part 2) : 1999	Tractors and machinery for agriculture and forestry — Technical means for ensuring safety: Part 2 Tractors (<i>first revision</i>)
12371 : 1988	Technical requirements for single acting tipping cylinders for agricultural trailers.
13135 : 1991	Automotive vehicles — Electronic flashers
13154 : 1991	Automotive vehicles — Tyres for agricultural tractors, implements and power tillers.

3 TERMINOLOGY

3.0 For the purpose of this standard following definitions, in addition to those given in 3 of IS 9821, shall apply:

3.1 Reflex Reflectors — An assembly ready for use and comprising one or more reflecting optical units. Reflectors shall be visible at night from all distances within 31 m to 183 m when directly in front of lawful lower beams of headlamps.

3.2 Lamp Location — Dimensions in this standard, unless specified otherwise, are based on measurements to the lamp filament.

3.3 Head Light — Illuminating light of a vehicle intended to illuminate the road ahead.

3.4 Stop Light — A brake operated lighting device which emits red or amber light at the rear of the vehicle intended to give warning of the slowing down or the stopping of the vehicle.

3.5 Direction Indicator — A lighting device to show in which direction, the driver intends to turn by giving a flashing light on the side of the vehicle towards which the turn will be made.

3.6 Tail Light — A lighting device which emits red light indicating the presence of the vehicle when seen from the rear and intended to show the width.

3.7 Reversing Light — A device used to provide a warning signal to pedestrians and other drivers, when the vehicle is reversing or is about to reverse. The light shall be white in colour.

4 TYPES

4.1 The agricultural trailers shall be of following two types:

- a) Balanced trailer (double axle) (see Fig. 1), and
- b) Semi-trailer (single axle) (see Fig. 2).

4.1.1 Both the types of trailers may be fitted with fixed or tipping platform.

5 MATERIALS

5.1 The material for important components and that for axle assembly shall be as given in col 3 of Table 1.

The material may conform to the relevant Indian Standard and grade given in col 4 and 5 of Table 1.

Table 1 Material Requirements for Components of Trailer
(Clause 5.1)

Sl No.	Components	Material	Ref to IS No.	Grade
(1)	(2)	(3)	(4)	(5)
i)	Chassis	Mild steel	IS 2062	Fe 410-S
ii)	Drawbar	Mild steel	IS 2062	Fe 410-S
iii)	Tow eye or tow jaw	Carbon steel	IS 1875 or IS 1030	20 C Grade 23 to 45
iv)	Platform	Mild steel	IS 2062	Fe 410-S
v)	Side boards	Mild steel	IS 2062	Fe 410-S
		Timber	IS 2179	
vi)	Leaf spring	Spring steel	IS 3431	—
vii)	Axle	Structural steel	IS 2062	Fe 410-S
viii)	Hub	Cast iron	IS 210	FG 200
ix)	Brake drum	Cast iron	IS 210	FG 200
x)	Cap	Cast iron	IS 210	FG 200
		Mild steel	IS 1079	—
xi)	Washer	Mild steel	IS 2062	—

6 CAPACITY

6.1 The capacity of a trailer shall be its gross load and shall be 2, 3, 4, 5, 6, 8 and 10 tonnes. The gross load along with the pay load shall be declared by the manufacturer. The declared capacity shall not vary by ± 5 percent.

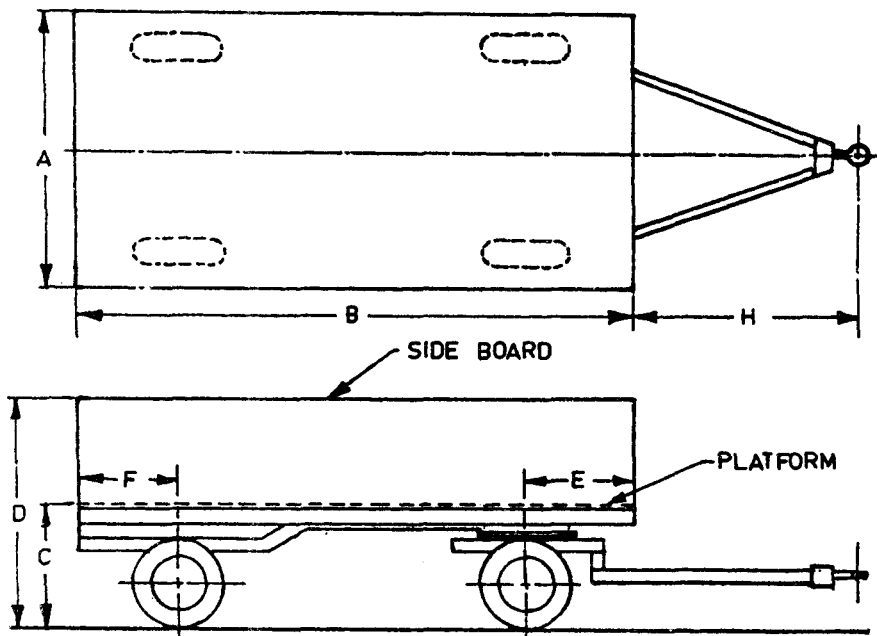

FIG. 1 BALANCED TRAILER

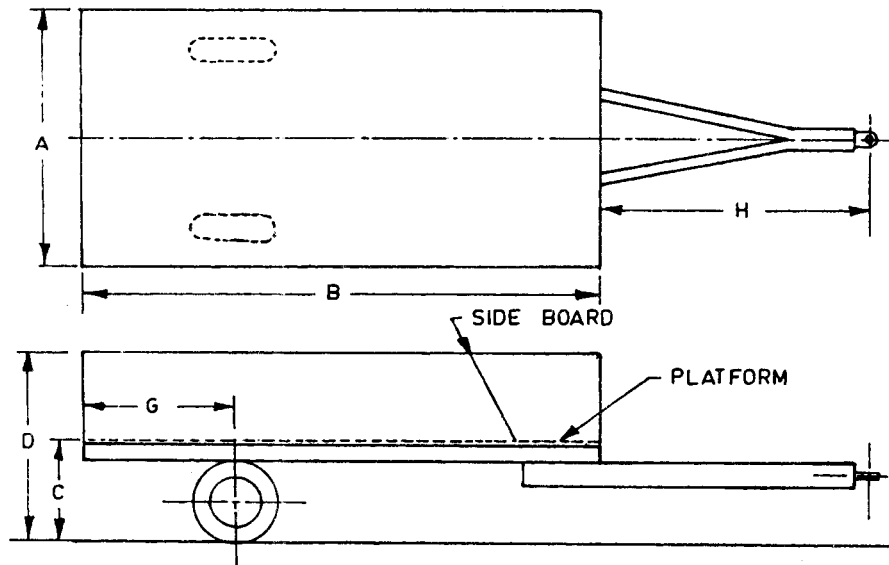

FIG. 2 SEMI-TRAILER

6.1.1 The capacity of the single-axle trailers shall be not more than 5 tonnes.

7 DIMENSIONS

7.1 The dimensions given under 7.2 to 7.8 shall not in any way infringe the rules and regulations of the local transport authority.

7.2 The overall width of the trailer (see *A* in Fig. 1 and Fig. 2) measured between the extreme points shall not exceed 2.5 m.

7.3 The overall length of the platform (see *B* in Fig. 1 and Fig. 2) shall not exceed the following:

- 5 m for trailers up to 5 tonnes capacity, and
- 6.7 m for trailers above 5 tonnes capacity.

7.4 The height of the trailer, with tyres inflated at the recommended pressure, when measured from the level supporting surface to the top of the platform (see *C* in Fig. 1 and Fig. 2) shall be not more than 1.5 m.

7.5 The height of the trailer, with tyres inflated at the recommended pressure, when measured from the level supporting surface to the top of the sideboard (see *D* in Fig. 1 and Fig. 2) shall be not more than 2.2 m.

7.6 In case of the balanced trailer, the distance from the edge of the platform to the centre of front wheel (see *E* in Fig. 1) and from rear edge of the platform to the centre of rear wheel (see *F* in Fig. 1) shall be not more than 0.8 m.

7.7 In case of semi-trailer, the load transfer from the trailer to the tow eye of the trailer shall not be more than 20 percent of the trailer capacity. Assuming that the trailer is loaded uniformly to the entire length of

platform and the centre of gravity lies in the lateral vertical plane at half the length of platform from rear edge, the value of *G* (see Fig. 2) can be derived from the following formula:

$$G = \frac{\frac{W \cdot B}{2} - R_t(H + B)}{(W - R_t)}$$

where

W = gross load of the trailer; and

R_t = load transfer on tow eye, percent.

7.7.1 On the basis of 20 percent load transfer from the trailer to the tow eye, the above formula can be written as follows:

$$G = \frac{3B - 2H}{8}$$

7.8 Ground clearance shall not be less than 300 mm.

8 CONSTRUCTIONAL REQUIREMENTS

8.1 The loading platform may be plain or provided with hinged or fixed sideboards. If trailer is provided with sideboards, some kind of locking provision shall be provided to keep it vertical. This can be met by giving a latching system at the top of the vertical posts fitted to the platform. The hinges by which sideboards are fixed shall be provided with split pins to restrict its lateral motion.

8.2 The trailers shall be provided with lashing hooks for tying down the load.

8.3 For single-axle trailer, tow eye of the drawbar or

hitch of the trailer, when fully loaded may be parallel to the level surface after hitching with towing tractor, for balanced trailer drawbar or hitch of the trailer shall be of hinged type so that load from trailer is not transferred to the towing tractor. In the towing hitch, a suitable shock absorbing device shall be provided. The hitch height of trailer should always be below rear axle height of the tractor.

8.4 Tow eye of the trailer shall be capable of rotating at 360° angle to take on even rigid trailer hook of the towing tractor. Ring type hitches shall conform to IS 11270.

8.5 For balanced trailers, the front axle shall have the capability to swivel to a maximum of 120° (60° on either side) about the vertical axis.

8.6 The trailer shall be fitted with pneumatic tyres and rims conforming to IS 13154 and 10694 (Part 6) respectively.

8.7 The axle(s) shall conform to requirements specified in Annex A.

8.8 The trailer shall be provided with suitable spring suspension (*see* IS 1135) for recommended load carrying capacity.

8.9 Trailers shall have service (overrun) and parking brake. It shall be ensured that during operation of service or parking brake, the brakes at both the wheels of trailer are activated simultaneously.

8.9.1 The service brakes shall be capable of a deceleration of 2.5 m/s² measured in accordance with the method described in Annex B with operating brakes pedal force not exceeding 600 N and 400 N in case of foot operated and hand operated brakes respectively.

8.9.2 The parking brake shall hold fully laden trailer on a 12 percent slope uphill or downhill. The maximum force to operate a hand lever shall not exceed 400 N. The parking brake shall operate on the same drum and shoe or disc and pad as the service brake.

8.10 Hydraulic ram of suitable capacity compatible with tractor hydraulic shall be provided in case of tipping type. The ram may be used in single or tandem as per need and the operating pressure shall not exceed 13.8 MPa.

8.11 Tipping angle of the body, in case of tipping type, shall be 42° to 50°.

9 LIGHTING REQUIREMENTS

9.1 The trailer shall be fitted with two red coloured reflectors at rear sides and two white coloured reflectors on front sides at a distance not more than

150 mm from extreme ends to the centre of reflectors. The reflectors shall be round with reflecting area not less than 3 000 mm². Rear reflectors may be incorporated as part of lensing in tail lamps described in 9.2.

9.2 Every trailer shall be provided with two tail lights of red colour at the rear and conforming to IS 3628. The point on the illuminating surface farthest from the median longitudinal plane of trailer shall be not more than 400 mm from the extreme outer edge of the vehicle. The distance between the inner edge of the two illuminating surface shall be not less than 600 mm. This distance may be reduced to 400 mm, where the overall width of the trailer is less than 1 300 mm. The height of tail lights above the ground shall be not less than 350 mm and not more than 1 600 mm.

9.3 At least two amber flashing reversing lamps (warning lamps) conforming to IS 4060 or IS 13135 as symmetrically mounted and as widely spaced laterally as practicable, visible from both front and rear, mounted at least 1 000 mm height but not more than 1 500 mm. Lamps shall flash in unison at a rate of 60 to 120 flashes per minute.

9.4 Every trailer shall be fitted with two turn indicators (Direction indicators) lamps on the rear side. The direction indicator shall be of amber colour and shall flash in unison at a rate of 60 to 120 flashes per minute. The light emitted by lamps when in operation shall be clearly visible from both front and rear of the vehicle. The direction indicator shall be so designed and fitted that the tractor operator is aware that it is operating correctly. Illuminated area of each direction indicator shall not be less than 2 250 mm².

9.4.1 The rear amber flashing warning lamps (*see* 9.3) may be used as the turn indicators.

9.5 Two brake operated stop light shall be provided at the rear of the trailer which emit red light intended to give warning of the slowing down or stopping of the vehicle. The stop lights may be provided as a part of tail lamps (*see* 9.2).

9.6 A slow moving vehicle emblem conforming to 7 of IS 12239 (Part 2) shall be provided on the rear side of the trailer.

10 OTHER REQUIREMENTS

10.1 The semi-trailer shall be provided with suitable arrangement in the front for keeping the trailer in a levelled position when detached from the towing tractor.

10.2 All the parts requiring lubrication shall be provided with suitable arrangement which should be easily accessible and indicated with symbols as per IS 6283 (Part 1).

10.3 A suitable unobstructed location shall be made available on the trailer chassis for fixing a lift jack for carrying out necessary repairs to the trailers.

10.4 In case of tipping type trailer, provisions shall be made for tilting the platform without disturbing the trailer.

10.4.1 Single telescopic tipping cylinder shall meet the requirements specified in IS 12371.

10.5 When the trailer is loaded uniformly with 25 percent additional pay load and operated at an average speed of 25 km/h to 30 km/h for 3 hours. It shall not show any sign of breakage or deformation in any part. This test shall be conducted on metalled road.

11 WORKMANSHIP AND FINISH

11.1 The sharpness of the edges and corners shall be removed.

11.2 Castings and forgings shall be free from blow holes, cracks and other visual defects.

11.3 Welding shall not be porous. As far as possible, it should be done in accordance with IS 816.

11.4 All wooden and metal surfaces shall be covered with a coat of suitable preservative. The metal parts

should be de-rusted, treated with anti-corrosive material and an appropriate primer painting.

11.5 No trailer should be painted in olive green colour except these belonging to Defence Department.

12 MARKING

12.1 The trailer shall be marked with the following information on identification plate which shall be welded or rivetted to the body:

- a) Manufacturer's name and registered trademark, if any;
- b) Unladen mass;
- c) Gross load; and
- d) T-sign at the rear (*see* IS 9942).

12.2 BIS Certification Marking

The trailer may also be marked with the Standard Mark.

12.2.1 The use of the Standard Mark is governed by the provisions of *Bureau of Indian Standards Act, 1986* and the Rules and Regulations made thereunder. The details of conditions under which the licence for the use of Standard Mark may be granted to manufacturers or producers may be obtained from the Bureau of Indian Standards.

ANNEX A

(Clause 8.7)

REQUIREMENT OF AXLE ASSEMBLY

A-1 NOMENCLATURE

A-1.1 For the axle assembly the nomenclature given in Fig. 3 shall apply.

A-2 CLASSIFICATION

A-2.1 For the purpose of this standard, the axle assembly shall be of the following two classes:

- a) *Class A* — The axle assembly of load carrying capacity up to 3 tonnes.
- b) *Class B* — The axle assembly of load carrying capacity up to 5 tonnes.

A-3 DIMENSIONAL REQUIREMENTS

A-3.1 The dimensions of various components of the

axle assembly shall be as given in col 3 and 4 of Table 2. The applicable standards for the components are given in col 5 of Table 2 for guidance.

A-3.2 The axle assembly shall have wheel track of 1 500 mm or 1 700 mm.

A-4 OTHER REQUIREMENTS

A-4.1 The dust cover shall be fitted with the help of three round head screws and spring washers.

A-4.2 Oil seals or grease retainers shall be provided to make the axle assembly leak and dust proof. Oil seals should conform to IS 5129.

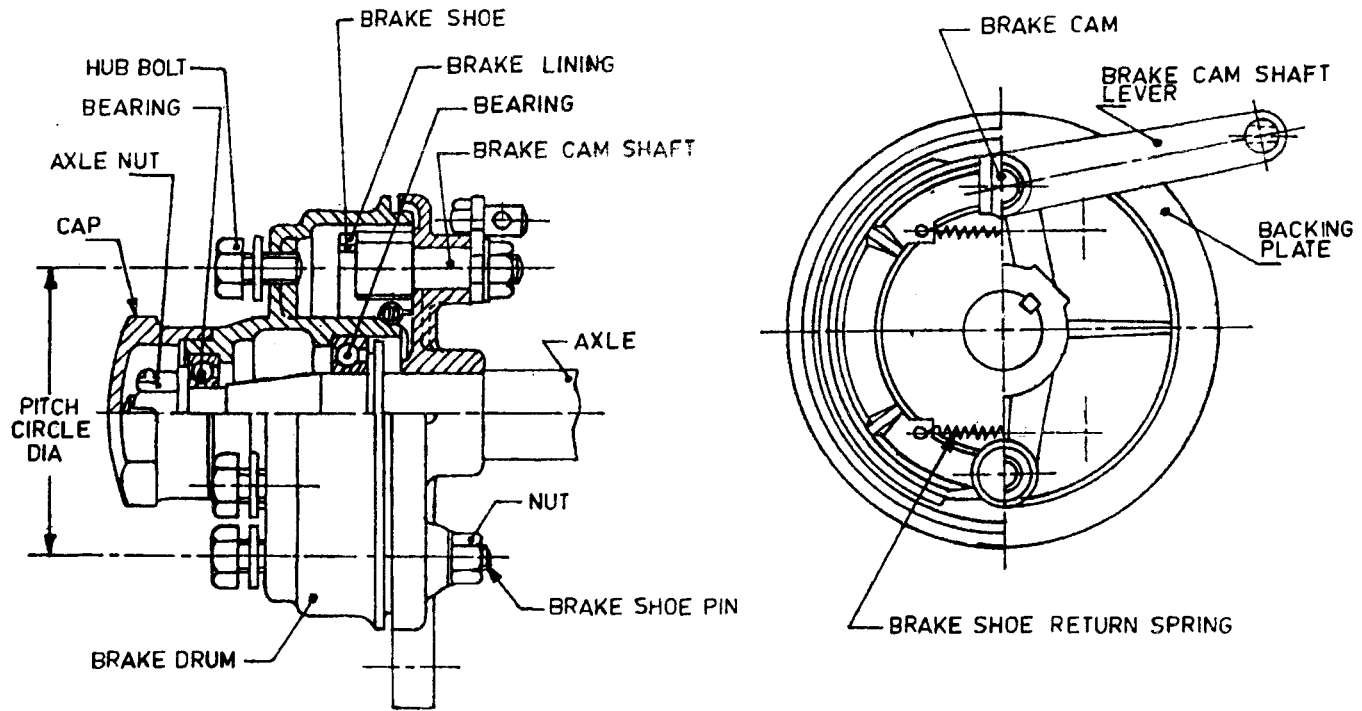

FIG. 3 NOMENCLAUTRE OF AXLE ASSEMBLY

Table 2 Dimensions of Various Components of Axle Assembly
(Clause A-3.1)

Sl No.	Component	Dimensions		Applicable Standard
		Class A (3)	Class B (4)	
(1)	(2)			(5)
i)	Axle shaft size, mm	63 square or 80 round	75 square or 80 round	IS 2062
ii)	Outer bearing, bore size diameter, mm	45	45	Size designation DB of IS7461(Part 2)
iii)	Inner bearing, bore size diameter, mm	55	55	-do-
iv)	Castle nut, nominal size	M 42 × 1.5	M 42 × 1.5	IS 2232
v)	Split pin for nut, nominal diameter, mm	8	8	IS 549
vi)	Washer for nut, nominal size, mm	43/45	43/45	IS 2016
vii)	Roundhead screw:			—
	a) Nominal size	M 6 × 1	M 6 × 1	
	b) Length, mm	12	12	
	c) Number	3	3	
viii)	Wheel stud:			—
	a) Nominal size	M 16 × 1.5	M 16 × 1.5	
	b) Pitch circle diameter, mm	165	185	
	c) Number	5	6	
ix)	Hub flange:			—
	a) Thickness, mm	20	25	
	b) Diameter, mm	210	230	
x)	Brake drum:			—
	a) Diameter, mm	254	254	
	b) Nominal width, mm	50	50	

A-4.3 The hub shall be fully packed with multi-purpose grease between the bearings.

A-5 DESIGNATION

A-5.1 An axle assembly shall be designated by its class and wheel track.

A-5.1.1 Example 1

An axle assembly of Class A having wheel track of 1 500 mm shall be designated as:

Axle A 1 500

A-5.1.2 Example 2

An axle assembly of Class B having wheel of 1 700 mm shall be designated as:

Axle B 1 700

A-6 WORKMANSHIP AND FINISH

A-6.1 The castings shall be free from blow holes, pits, burrs and other visual defects.

A-6.2 The sharp edges shall be removed.

A-6.3 A protective coating shall be provided.

ANNEX B

(Clause 8.9.1)

COLD BRAKE PERFORMANCE TEST

B-1 GENERAL

B-1.1 During all the tests of service brake the trailed vehicle shall be coupled to a towing vehicle with which it is recommended for use by the manufacturer.

B-2 TEST CONDITIONS

B-2.1 The test surface shall not exceed one percent longitudinal slope and 3 percent side slope.

B-2.2 The trailer should be loaded to the maximum specified gross capacity.

B-2.3 In case of a multiple-axle trailer having any unbraked axles, the unbraked axles shall be loaded to its maximum axle load. For trailed vehicles having more than one axle and brakes on all wheels, the front axle shall be loaded to its maximum axle load.

B-2.4 The test track shall have a dry, clean, concrete, bituminous or an equivalent surface having good adhesion.

B-2.5 The test shall be performed when the wind velocity is below 10 m/s.

B-2.6 The braked axle(s) shall be equipped with the largest diameter tyres specified by the vehicle manufacturer. The tyres shall be inflated to pressure(s) specified by the vehicle manufacturer.

B-2.7 At the start of each test, the brakes shall be cold. A brake is deemed to be cold if one of the following condition is met:

- a) The temperature measured over the disc or on the outside of the drum is below 100°C;
- b) In the case of totally enclosed brakes, including oil immersed brakes, the temperature measured on the outside of the housing is below 50°C, or within manufacturer's specifications; and
- c) The brakes have not been actuated for one hour.

B-3 PROCEDURE

B-3.1 Prior to the start of the test, the brakes shall have been fully bedded-in (burnished) and adjusted in accordance with the manufacturer's instructions. Thereafter, the brakes shall not be further manually adjusted during the complete test.

B-3.2 With the towing vehicle and trailed vehicle travelling at the maximum design speed of the trailed

vehicle but not exceeding 30 km/h, measure deceleration for a series of different forces applied to the control of the braking device. Calculate the corresponding values of mean deceleration from the following formula:

$$a = \frac{v^2}{2s}$$

where

- a = average deceleration in m/s;
 v = initial speed in m/s; and
 s = stopping distance in m.

B-3.3 If the trailed vehicle service braking device control is independent of the towing vehicle braking device control, apply the trailed vehicle brakes only. When the brakes of trailed vehicle is operated, the engine in the towing vehicle shall be disengaged by the clutch so that the force to stop entire system shall come from brakes of trailed vehicle.

B-3.4 If the braking device transmission is not mechanical, measure an appropriate transmission parameter, such as fluid pressure, during each stop in such a way that the measurement does not interfere with the dynamic characteristics of the braking system.

B-3.5 Repeat the procedure for a series of different forces applied to the control of the braking device up to maximum force which can be applied without locking of the wheels, or up to a maximum input force of 600 N for foot-operated controls or 400 N for hand-operated controls if the braked wheels are not locked.

B-3.6 For each value of force applied to the braking device control, calculate the trailed vehicle braking force from whichever of the following formula is appropriate:

B-3.6.1 If the trailed vehicle brakes only are applied, use the following formula:

$$F_2 = (m_1 + m_2) a_3$$

where

- F_2 = the trailed vehicle braking force in N;
 m_1 = the towing vehicle mass in kg;
 m_2 = the trailed vehicle mass in kg; and
 a_3 = the mean deceleration of the towing and trailed vehicle combination in m/s².

B-3.6.2 If the towing and trailed vehicle brakes are

applied, use the following formula:

$$F_2 = (m_1 + m_2) a_3 - m_1 a_1$$

where

a_1 = mean deceleration measured with the towing vehicle alone at the same value of force applied to the towing vehicle braking device control which produced deceleration a_3 of the vehicle combination in m/s.

B-3.7 For each value of braking force F_2 , calculate the equivalent mean deceleration (a_2) of the trailed vehicle from the following formula:

$$a_2 = \frac{F_2}{m_2} \text{ m/s}^2$$

B-3.8 For each value of the equivalent mean deceleration a_2 , calculate the equivalent stopping distance s_2 of the trailed vehicle from the following formula:

$$s_2 = \frac{v_2^2}{2a_2}$$

where

s_2 = equivalent stopping distance of the trailed vehicle in m; and

v_2 = measured initial velocity of the trailed vehicle in m/s.

B-3.9 Repeat the test with the trailed vehicle unladen.

B-4 REPORT

B-4.1 Report for both the laden and the unladen trailed vehicle, the relationship between input force, stopping distance mean deceleration either in the form of a graph or table values.

B-4.1.1 If the braking device transmission is not mechanical, report the relationship between stopping distance, mean deceleration and an appropriate transmission parameter, such as fluid pressure, in the form of a graph or table of corresponding values.

B-5 TOLERANCE

The following measuring tolerance shall be adhered to when conducting the test:

<i>Measurement</i>	<i>Tolerance, percent</i>
Travel speed	± 3
Vehicle mass	± 3
Deceleration	± 3
Stopping distance	± 1
Brake control input force	± 5
Tyre inflation pressure	± 5
Brake system fluid (gas)	± 5

Bureau of Indian Standards

BIS is a statutory institution established under the *Bureau of Indian Standards Act, 1986* to promote harmonious development of the activities of standardization, marking and quality certification of goods and attending to connected matters in the country.

Copyright

BIS has the copyright of all its publications. No part of these publications may be reproduced in any form without the prior permission in writing of BIS. This does not preclude the free use, in the course of implementing the standard, of necessary details, such as symbols and sizes, type or grade designations. Enquiries relating to copyright be addressed to the Director (Publication), BIS

Review of Indian Standards

Amendments are issued to standards as the need arises on the basis of comments. Standards are also reviewed periodically; a standard along with amendments is reaffirmed when such review indicates that no changes are needed; if the review indicates that changes are needed, it is taken up for revision. Users of Indian Standards should ascertain that they are in possession of the latest amendments or edition by referring to the latest issue of 'BIS Handbook' and 'Standards: Monthly Additions'.

This Indian Standard has been developed from Doc: No. **FAD 59 (693)**.

Amendments Issued Since Publication

Amend No.	Date of Issue	Text Affected

BUREAU OF INDIAN STANDARDS

Headquarters:

Manak Bhavan, 9 Bahadur Shah Zafar Marg, New Delhi 110002
Telephones: 323 01 31, 323 3375, 323 94 02

Telegrams: Manaksanstha
(Common to all offices)

Regional Offices:

Central : Manak Bhavan, 9 Bahadur Shah Zafar Marg
NEW DELHI 110002

Telephone
323 76 17, 323 38 41

Eastern : 1/14 C.I.T. Scheme VII M, V.I.P. Road, Kankurgachi
CALCUTTA 700054

{ 337 84 99, 337 85 61
{ 337 86 26, 337 91 20

Northern : SCO 335-336, Sector 34-A, CHANDIGARH 160022

{ 60 38 43
{ 60 20 25

Southern : C.I.T. Campus, IV Cross Road, CHENNAI 600113

{ 235 02 16, 235 04 42
{ 235 15 19, 235 23 15

Western : Manakalaya, E9 MIDC, Marol, Andheri (East)
MUMBAI 400093

{ 832 92 95, 832 78 58
{ 832 78 91, 832 78 92

Branches : AHMADABAD. BANGALORE. BHOPAL. BHUBANESHWAR.
COIMBATORE. FARIDABAD. GHAZIABAD. GUWAHATI.
HYDERABAD. JAIPUR. KANPUR. LUCKNOW. NAGPUR.
PATNA. PUNE. RAJKOT. THIRUVANANTHAPURAM.