

इंटरनेट

मानक

Disclosure to Promote the Right To Information

Whereas the Parliament of India has set out to provide a practical regime of right to information for citizens to secure access to information under the control of public authorities, in order to promote transparency and accountability in the working of every public authority, and whereas the attached publication of the Bureau of Indian Standards is of particular interest to the public, particularly disadvantaged communities and those engaged in the pursuit of education and knowledge, the attached public safety standard is made available to promote the timely dissemination of this information in an accurate manner to the public.

“जानने का अधिकार, जीने का अधिकार”

Mazdoor Kisan Shakti Sangathan

“The Right to Information, The Right to Live”

“पुराने को छोड़ नये के तरफ”

Jawaharlal Nehru

“Step Out From the Old to the New”

IS 5781 (1993): Fruit and Vegetable Products -
Determination of Dry Matter Content by Drying Under Reduced
Pressure and of Water Content by Azeotropic Distillation
[FAD 10: Processed Fruits and Vegetable Products]



“ज्ञान से एक नये भारत का निर्माण”

Satyanarayan Gangaram Pitroda

“Invent a New India Using Knowledge”



“ज्ञान एक ऐसा खजाना है जो कभी चुराया नहीं जा सकता है”

Bhartrhari—Nitiśatakam

“Knowledge is such a treasure which cannot be stolen”

BLANK PAGE



भारतीय मानक

फल और सब्जी उत्पाद — अपचायक दाब में सुखाकर
शुष्क पदार्थ अंश और एज्योट्रोपिक आसवन से पानी
अंश ज्ञात करना

(पहला पुनरीक्षण)

Indian Standard

FRUIT AND VEGETABLE PRODUCTS —
DETERMINATION OF DRY MATTER CONTENT BY
DRYING UNDER REDUCED PRESSURE AND OF
WATER CONTENT BY AZEOTROPIC DISTILLATION
(*First Revision*)

UDC 664'83/'87 : 543'8

© BIS 1993

BUREAU OF INDIAN STANDARDS
MANAK BHAVAN, 9 BAHADUR SHAH ZAFAR MARG
NEW DELHI 110002

NATIONAL FOREWORD

This Indian Standard which is identical with ISO 1026 : 1982 'Fruit and vegetable products -- Determination of dry matter content by drying under reduced pressure and of water content by azeotropic distillation', issued by the International Organization for Standardization (ISO), was adopted by the Bureau of Indian Standards on the recommendations of the Processed Fruits and Vegetable Products Sectional Committee (FAD 10) and approval of the Food and Agriculture Division Council.

This Indian Standard is the first revision of IS 5781 : 1970 'Method for determination of total solids in fruit and vegetable products' which was based on ISO/R 1026 : 1969 'Determination of total solids in fruit and vegetable products', issued by the International Organization for Standardization (ISO). ISO 1026 : 1982 cancels and replaces ISO/R 1026 : 1969.

In the adopted Indian Standard, some terminology and certain conventions are not identical with those used in Indian Standards. Attention is especially drawn to the following:

- a) Wherever the words 'International Standard' appear referring to this standard, they should be read as 'Indian Standard'.
- b) Comma (,) has been used as a decimal marker while in Indian Standards, the current practice is to use a point (.) as the decimal marker.

For the purpose of deciding whether a particular requirement of this standard is complied with, the final value, observed or calculated, expressing the result of a test or analysis, shall be rounded off in accordance with IS 2 : 1960 'Rules for rounding off numerical values (*revised*).' The number of significant places retained in the rounded off value should be the same as that of the specified value in this standard.

Indian Standard

FRUIT AND VEGETABLE PRODUCTS — DETERMINATION OF DRY MATTER CONTENT BY DRYING UNDER REDUCED PRESSURE AND OF WATER CONTENT BY AZEOTROPIC DISTILLATION

(First Revision)

1 Scope and field of application

This International Standard specifies a method for the determination of the dry matter content of fruit and vegetable products by drying under reduced pressure, and a method for the determination of water content by azeotropic distillation.

The method by drying under reduced pressure is applicable to all fruit and vegetable products, with the exception, however, of products for which drying would modify the state of the components, and of certain products having a water content below 10 %.

In these latter cases, the dry matter content may be obtained by difference after determination of the water content by azeotropic distillation. This latter method, however, is subject to certain restrictions, for example products soluble in water or benzene, or products rich in certain volatile substances or fermentation products.

2 Determination of dry matter content

2.1 Definition

dry matter : The whole of the substances which do not volatilize under the conditions of drying specified in this International Standard.

2.2 Principle

After mixing, heating to constant mass of liquid or semi-liquid products spread over an absorbent surface, or of pasty products mixed with an inert powder, at 70 °C under reduced pressure.

2.3 Apparatus

Usual laboratory equipment, and in particular

2.3.1 Oven, allowing drying to be carried out at 70 °C under a pressure of about 3 kPa¹⁾, while allowing a slow current of dry air (see 2.7.3) to enter at a rate of 10 or 40 l/h, as appropriate, measured at atmospheric pressure before entry into the oven; air introduced by means of a tap shall be dried, for example by passing it, one bubble at a time, into a wash bottle

containing sulphuric acid, placed in front of the tap ensuring expansion of the air. The temperature shall be uniform at all points in the oven.

2.3.2 Desiccator, provided with an efficient desiccant.

2.3.3 Dishes, of corrosion-resistant metal (aluminium, nickel, or, preferably, thin stainless steel), cylindrical with a flat bottom (for example, of diameter about 60 mm and height 25 mm), provided with well-fitting lids (see 2.7.1).

2.3.4 Glass rods, of length appropriate to the size of the dishes (2.3.3).

2.3.5 Analytical balance.

2.4 Materials

2.4.1 Paper strips, for liquid products.

Use ashless filter paper. Alternatively, filter paper previously washed for 8 h in 2 g/l hydrochloric acid solution, rinsed five times with distilled water and dried in air may also be used. Cut the paper into strips 20 mm wide. Crimp or fold in accordion fashion with close pleats, or more simply wind round a triangular mandrel of 1 cm sides. The strip partially uncoils itself, giving a polygonal spiral. Place 4 to 4,5 g of paper in each dish, i.e. either 3 m of paper strip if the grammage of the paper is between 60 and 70 g/m², or 1 m if a thick paper, of grammage 180 to 200 g/m², is used.

2.4.2 Paper discs, for semi-liquid products.

Use discs of strong ashless filter paper, crimped, cut to a diameter slightly less than that of the dishes. If ashless filter paper is not available, treat a filter paper as described in 2.4.1.

2.4.3 Pure sand, for thick or solid products.

Use pure sand which has been washed with 5 % (m/m) hydrochloric acid solution, rinsed until free from hydrochloric acid (verifying the absence of chloride ions in the washings by means of silver nitrate solution), sieved so that the grains are of sizes within the range 10³ to 400 µm, and calcined.

¹⁾ 3 kPa = 30 mbar

2.5 Procedure

NOTE — The water used shall be distilled water or water of at least equivalent purity.

2.5.1 Preparation of the test sample

Thoroughly mix the laboratory sample.

2.5.2 Preparation of the apparatus

2.5.2.1 Liquid or semi-liquid products

Dry in the oven, under the conditions specified in 2.3.1, with its lid placed alongside, a metal dish (2.3.3) (see 2.7.1), in which paper strips (2.4.1), or two paper discs (2.4.2), have been placed, as appropriate. After 1 h in the oven, weigh the dish to the nearest 0,000 2 g after cooling in the desiccator (2.3.3), and fitting the lid before removing the dish from the oven.

2.5.2.2 Thick, pulpy or heterogeneous products

Dry in the oven, under the conditions specified in 2.3.1, with its lid placed alongside, a metal dish (2.3.3) (see 2.7.1), in which 10 to 20 g of sand (2.4.3) and a glass rod (2.3.4) have been placed. After 1 h in the oven, weigh the dish to the nearest 0,000 2 g after cooling in a desiccator (2.3.2), and fitting the lid before removing the dish from the oven.

2.5.3 Test portion

2.5.3.1 Liquid or semi-liquid products

Take, by means of a pipette, 10 ml [in the case of liquid products (see the note)] or a few millilitres (in the case of semi-liquid products) of the test sample (2.5.1) and completely soak the paper strips or discs, as appropriate, in the dish, avoiding the accumulation of excess liquid against the metal.

Operate as rapidly as possible to avoid evaporation. Cover the dish and weigh to the nearest 0,000 2 g. In the case of semi-liquid products, soaking may be facilitated by moistening the paper discs with water before weighing the test portion.

NOTE — In the case of liquid products, if it is desired to express the dry matter content in grams per 100 ml of product, take the 10 ml using a precision pipette. In this case, ignore the second paragraph above.

2.5.3.2 Thick, pulpy or heterogeneous products

Transfer 2 to 5 g of the test sample to the dish and weigh to the nearest 0,000 2 g. Mix intimately with the sand by means of the glass rod, taking great care to avoid any loss of product or sand from the dish. If mixing is difficult, a little water may be added, provided that this is done after weighing the test portion.

2.5.4 Determination

Put the dish containing the paper, test portion and accessories with which they were weighed (see 2.5.3.1 or 2.5.3.2) into the oven (2.3.1), controlled at 70 °C, with the lid alongside the dish. Reduce the pressure to 3 kPa while passing a current of dry air at a flow rate of 40 l/h (see 2.3.1, 2.6.2 and 2.7.3).

Dry for 3 h in the case of liquid or semi-liquid products, or for 4 h in other cases. Cool in the desiccator, fitting the lid before removing the dish from the oven, and then weigh to the nearest 0,000 2 g.

Repeat the drying until the difference between two consecutive weighings, separated by an interval of 1 h, does not exceed 0,001 g.

2.5.5 Number of determinations

Carry out two determinations on the same test sample (2.5.1).

2.6 Expression of results

2.6.1 Method of calculation and formula

The dry matter content, expressed as a percentage by mass, is equal to

$$(m_2 - m_0) \times \frac{100}{m_1 - m_0}$$

where

m_0 is the mass, in grams, of the dish and accessories (paper or sand and rod, lid) (see 2.5.2.1 or 2.5.2.2);

m_1 is the mass, in grams, of the same dish containing the test portion before drying (see 2.5.3.1 or 2.5.3.2);

m_2 is the mass, in grams, of the same dish after drying.

Take as the result the arithmetic mean of the values obtained in the two determinations (2.5.5), provided that the requirement for repeatability (see 2.6.2) is satisfied.

NOTES

1 In the case of products having low water contents, the result may be expressed as a percentage by mass of water.

2 For liquid products, if the test portion was taken by volume (see the note in 2.5.3.1), the dry matter content, expressed in grams per 100 ml of product, is equal to

$$(m_2 - m_0) \times \frac{100}{V}$$

where

V is the volume, in millilitres, of the test portion;

m_2 and m_0 have the same meanings as above.

2.6.2 Repeatability

The difference between the values obtained in the two determinations (2.5.5), carried out simultaneously or in rapid succession by the same analyst, shall not exceed

1 % (relative) for dry matter contents greater than 10 g per 100 g or per 100 ml of sample;

2 % (relative) for dry matter contents less than or equal to 10 g per 100 g or per 100 ml of sample.

2.7 Notes on procedure

2.7.1 If a filter-paper support is used, the airtightness of the dishes (2.3.3), can be checked as follows.

The mass of a dish containing filter paper and which has been dried as described in 2.5.2.1 and then closed with its lid and left exposed to the air of the laboratory after cooling in the desiccator (2.3.2), shall not increase by more than 0,001 g per hour.

2.7.2 In certain cases, especially for series of analyses, it may be preferable to fix the conditions of drying using the following methods of control.

A 100 ± 1 g/l solution of pure sucrose shall leave a total solids residue of 100 ± 1 g per litre.

A 10 g/l solution of pure lactic acid shall leave a total solids residue of at least 9,5 g per litre.

NOTE — The solution of lactic acid should be prepared as follows. Dilute 10 ml of pure lactic acid with about 100 ml of water. Heat this solution, in a dish, on a boiling water bath for 4 h, adding water if the volume falls below about 50 ml. Dilute the contents of the dish to 1 litre in a volumetric flask and titrate the lactic acid in 10 ml of this solution with a 0,1 mol/l alkaline solution.

Adjust the concentration to 10 g/l.

Fix the time in the oven, the rate of dry air flow, or the internal pressure to satisfy these conditions.

2.7.3 In certain cases, it is recommended that, for the first hour, drying should be carried out at 70 °C and 13,2 kPa¹⁾ and that the pressure should then be reduced to 3,3 kPa²⁾.

2.7.4 If there is a risk of oxidation when air is used, use an inert gas for sweeping the apparatus.

3 Determination of water content

3.1 Definitions

3.1.1 **water** : The aqueous distillate entrained and collected by the entrainment method specified in this International Standard.

The water content is expressed as a percentage by mass.

3.1.2 **dry matter** : The result obtained by subtracting from the mass of product, the mass of the water entrained under the conditions specified in this International Standard.

3.2 Principle

Entrainment of the water in the form of vapour by a volatile solvent immiscible with water, condensation and separation in a

reflux trap, recovery and measurement of the volume of water in a graduated tube.

3.3 Reagent

Benzene or toluene.³⁾

3.4 Apparatus

Usual laboratory equipment, and in particular

3.4.1 **Entrainment apparatus**, comprising the following items connected together by means of ground glass joints.

3.4.1.1 **Conical flask**, of capacity at least 500 ml.

3.4.1.2 **Reflux condenser**.

3.4.1.3 **Receiver**, comprising a tube graduated in 0,1 ml divisions, capable of being connected to the flask and the condenser (see the figure).

NOTE — In order to eliminate all traces of grease from the graduated tube and the interior of the condenser, clean the apparatus, for example with a chromic-sulphuric acid mixture, and wash it successively with distilled water and acetone. Then dry the apparatus in a current of air, without heating.

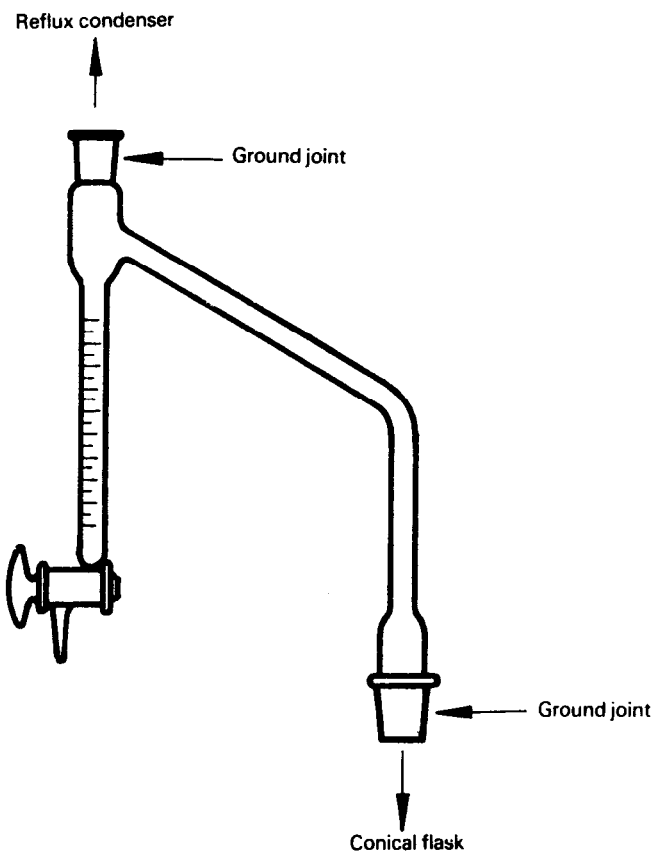

Figure — Receiver

1) 13,2 kPa = 132 mbar

2) 3,3 kPa = 33 mbar

3) The use of benzene is prohibited in some laboratories.

3.4.2 Electric heating apparatus, with a control system and a magnetic stirrer or a **boiling water bath**.

3.4.3 Balance.

3.5 Procedure

3.5.1 Preparation of the test sample

Thoroughly mix the laboratory sample.

3.5.2 Test portion

Weigh, to the nearest 0,1 g, the *maximum* quantity of laboratory sample (3.5.1) (a test portion of 50 g is generally suitable).

3.5.3 Determination

Transfer the test portion (3.5.2) quantitatively to the conical flask (3.4.1.1) with an amount of solvent (3.3) approximately the same as the mass of the test portion. For thick products, add a boiling regulator, for example a few pieces of pumice stone.

Fit the receiver (3.4.1.3) to the flask and condenser, then connect the tubes supplying the condenser.

Cautiously heat the flask on the electric heating apparatus or the boiling water bath (3.4.2) (see 3.7.2), and maintain gentle boiling until the distilled solvent becomes clear and no more water separates (about 3 h). The distillate shall fall drop by drop from the bottom of the condenser, at the rate of about 2 drops per second.

The water collects in the graduated tube.

At the end of the distillation, stop heating and shake the condenser so as to dislodge any drops of water and solvent adhering to the wall.

Allow the graduated tube to cool to ambient temperature, if necessary immersing it in water.

Read the volume of water collected in the graduated tube, after allowing sufficient time for the water to coalesce completely so that there is no emulsified zone (see 3.7.1).

3.5.4 Number of determinations

Carry out two determinations on the same test sample (3.5.1).

3.6 Expression of results

3.6.1 The water content, H , expressed as a percentage by mass of the product, is equal to

$$\frac{V}{m} \times 100$$

where

m is the mass, in grams, of the test portion (3.5.2);

V is the volume, in millilitres, of water collected in the graduated tube (the density of water is assumed to be 1 g/ml).

3.6.2 The dry matter content, expressed as a percentage by mass, is equal to

$$100 - H$$

where H is the water content calculated in 3.6.1.

3.7 Notes on procedure

3.7.1 If the graduation of the lower part of the graduated tube is in doubt, it is possible, before transferring the test portion to the conical flask, to pour solvent into the flask, adding a small quantity of water, depending on the volume of the lower part of the tube, and to distil until the volume of water in the graduated tube is constant. The meniscus should then always be in the accurate part of the receiver. The determination can then be carried out.

It is also possible to fill the graduated tube with water to a specific graduation line before performing the distillation.

3.7.2 In the case of pasty products, it is recommended that the boiling water bath be used for heating the conical flask.

4 Test report

The test report shall show the method used and the results obtained. It shall also mention all operating details not specified in this International Standard, or regarded as optional, as well as any incidents that may have influenced the results.

The test report shall include all the information necessary for the complete identification of the sample.

Standard Mark

The use of the Standard Mark is governed by the provisions of the *Bureau of Indian Standards Act, 1986* and the Rules and Regulations made thereunder. The Standard Mark on products covered by an Indian Standard conveys the assurance that they have been produced to comply with the requirements of that standard under a well defined system of inspection, testing and quality control which is devised and supervised by BIS and operated by the producer. Standard marked products are also continuously checked by BIS for conformity to that standard as a further safeguard. Details of conditions under which a licence for the use of the Standard Mark may be granted to manufacturers or producers may be obtained from the Bureau of Indian Standards.

Bureau of Indian Standards

BIS is a statutory institution established under the *Bureau of Indian Standards Act, 1986* to promote harmonious development of the activities of standardization, marking and quality certification of goods and attending to connected matters in the country.

Copyright

BIS has the copyright of all its publications. No part of these publications may be reproduced in any form without the prior permission in writing of BIS. This does not preclude the free use, in the course of implementing the standard, of necessary details, such as symbols and sizes, type or grade designations. Enquiries relating to copyright be addressed to the Director (Publications), BIS.

Revision of Indian Standards

Amendments are issued to standards as the need arises on the basis of comments. Standards are also reviewed periodically; a standard along with amendments is reaffirmed when such review indicates that no changes are needed; if the review indicates that changes are needed, it is taken up for revision. Users of Indian Standards should ascertain that they are in possession of the latest amendments or edition by referring to the latest issue of 'BIS Handbook' and 'Standards Monthly Additions'. Comments on this Indian Standard may be sent to BIS giving the following reference:

Doc : No. FAD 10 (287)

Amendments Issued Since Publication

Amend No.	Date of Issue	Text Affected

BUREAU OF INDIAN STANDARDS

Headquarters:

Manak Bhavan, 9 Bahadur Shah Zafar Marg, New Delhi 110002
Telephones : 331 01 31, 331 13 75

Telegrams : Manaksanstha
(Common to all Offices)

Regional Offices :

	Telephone
Central : Manak Bhavan, 9 Bahadur Shah Zafar Marg NEW DELHI 110002	{ 331 01 31 331 13 75
Eastern : 1/14 C. I. T. Scheme VII M, V. I. P. Road, Maniktola CALCUTTA 700054	{ 37 84 99, 37 85 61 37 86 26, 37 86 62
Northern : SCO 445-446, Sector 35-C, CHANDIGARH 160036	{ 53 38 43, 53 16 40 53 23 84
Southern : C. I. T. Campus, IV Cross Road, MADRAS 600113	{ 235 02 16, 235 04 42 235 15 19, 235 23 15
Western : Manakalaya, E9 MIDC, Marol, Andheri (East) BOMBAY 400093	{ 632 92 95, 632 78 58 632 78 91, 632 78 92
Branches : AHMADABAD. BANGALORE. BHOPAL. BHUBANESHWAR. COIMBATORE. FARIDABAD. GHAZIABAD. GUWAHATI. HYDERABAD. JAIPUR. KANPUR. LUCKNOW. PATNA. THIRUVANANTHAPURAM.	