

इंटरनेट

मानक

### Disclosure to Promote the Right To Information

Whereas the Parliament of India has set out to provide a practical regime of right to information for citizens to secure access to information under the control of public authorities, in order to promote transparency and accountability in the working of every public authority, and whereas the attached publication of the Bureau of Indian Standards is of particular interest to the public, particularly disadvantaged communities and those engaged in the pursuit of education and knowledge, the attached public safety standard is made available to promote the timely dissemination of this information in an accurate manner to the public.

“जानने का अधिकार, जीने का अधिकार”

Mazdoor Kisan Shakti Sangathan

“The Right to Information, The Right to Live”

“पुराने को छोड़ नये के तरफ”

Jawaharlal Nehru

“Step Out From the Old to the New”

IS/IEC 60898-1 (2002): Electrical accessories - Circuit-breakers for overcurrent protection for household and similar installations, Part 1: Circuit-breakers for ac operation [ETD 7: Low Voltage Switchgear and Controlgear]



“ज्ञान से एक नये भारत का निर्माण”

Satyanarayan Gangaram Pitroda

“Invent a New India Using Knowledge”



“ज्ञान एक ऐसा खजाना है जो कभी चुराया नहीं जा सकता है”

Bhartrhari—Nitiśatakam

“Knowledge is such a treasure which cannot be stolen”





BLANK PAGE



भारतीय मानक

विद्युत उपस्कर — घरेलू और समान संस्थापनों के लिए  
ओवरकरंट से सुरक्षा हेतु परिपथ वियोजक  
भाग 1 प्रत्यावर्ती धारा के प्रचालन के लिए परिपथ वियोजक

*Indian Standard*

**ELECTRICAL ACCESSORIES — CIRCUIT-BREAKERS  
FOR OVERCURRENT PROTECTION FOR  
HOUSEHOLD AND SIMILAR INSTALLATIONS**

**PART 1 CIRCUIT-BREAKERS FOR ac OPERATION**

ICS 29.120.50

© BIS 2008

**BUREAU OF INDIAN STANDARDS**  
MANAK BHAVAN, 9 BAHADUR SHAH ZAFAR MARG  
NEW DELHI 110002

## CONTENTS

1	Scope and object .....	1
2	Normative references .....	2
3	Definitions .....	3
3.1	Devices .....	3
3.2	General terms .....	4
3.3	Constructional elements .....	5
3.4	Conditions of operation .....	8
3.5	Characteristic quantities .....	8
3.6	Definitions related to insulation co-ordination .....	13
4	Classification .....	14
4.1	According to the number of poles .....	14
4.2	According to the protection against external influences .....	14
4.3	According to the method of mounting .....	15
4.4	According to the methods of connection .....	15
4.5	According to the instantaneous tripping current (see 3.5.17) .....	15
4.6	According to the $I^2t$ characteristic .....	15
5	Characteristics of circuit-breakers .....	16
5.1	List of characteristics .....	16
5.2	Rated quantities .....	16
5.3	Standard and preferred values .....	17
6	Marking and other product information .....	19
7	Standard conditions for operation in service .....	20
7.1	Ambient air temperature range .....	20
7.2	Altitude .....	20
7.3	Atmospheric conditions .....	20
7.4	Conditions of installation .....	21
7.5	Pollution degree .....	21
8	Requirements for construction and operation .....	21
8.1	Mechanical design .....	21
8.2	Protection against electric shock .....	27
8.3	Dielectric properties and isolating capability .....	28
8.4	Temperature-rise .....	29
8.5	Uninterrupted duty .....	29
8.6	Automatic operation .....	29
8.7	Mechanical and electrical endurance .....	31
8.8	Performance at short-circuit currents .....	31
8.9	Resistance to mechanical shock and impact .....	32
8.10	Resistance to heat .....	32
8.11	Resistance to abnormal heat and to fire .....	32
8.12	Resistance to rusting .....	32
9	Tests .....	32
9.1	Type tests and test sequences .....	32
9.2	Test conditions .....	33
9.3	Test of indelibility of marking .....	34



9.4	Test of reliability of screws, current-carrying parts and connections.....	34
9.5	Tests of reliability of screw-type terminals for external copper conductors .....	35
9.6	Test of protection against electric shock .....	37
9.7	Test of dielectric properties and isolating capability .....	37
9.8	Test of temperature-rise and measurement of power loss .....	42
9.9	28-day test .....	43
9.10	Test of tripping characteristic.....	44
9.11	Test of mechanical and electrical endurance .....	45
9.12	Short-circuit tests .....	47
9.13	Mechanical stresses .....	58
9.14	Test of resistance to heat .....	61
9.15	Resistance to abnormal heat and to fire (glow-wire test).....	62
9.16	Test of resistance to rusting.....	63
Annex A (informative) Determination of short-circuit power factor.....		76
Annex B (normative) Determination of clearances and creepage distances .....		77
Annex C (normative) Number of samples to be submitted and test sequences to be applied for verification of conformity (13.5 of ISO/IEC Guide 2:1991) .....		80
Annex D (informative) Co-ordination under short-circuit conditions between a circuit-breaker and another short-circuit protective device (SCPД) associated in the same circuit .....		85
Annex E (normative) Special requirements for auxiliary circuits for safety extra-low voltage.....		93
Annex F (informative) Examples of terminals.....		94
Annex G (informative) Correspondence between ISO and AWG copper conductors .....		97
Annex H (normative) Arrangement for short-circuit test .....		98
Annex I (normative) Routine tests .....		101
Annex J (normative) Particular requirements for circuit-breakers with screwless type terminals for external copper conductors.....		102
Annex K (normative) Particular requirements for circuit-breakers with flat quick-connect terminations.....		111
Annex L (normative) Specific requirements for circuit-breakers with screw-type terminals for external untreated aluminium conductors and with aluminium screw-type terminals for use with copper or with aluminium conductors.....		118
Bibliography .....		130
Figure 1 – Thread forming tapping screw (3.3.22) .....		63
Figure 2 – Thread cutting tapping screw (3.3.23).....		63
Figure 3 – Single pole circuit-breaker .....		64
Figure 4a – Two-pole circuit-breaker with one protected pole.....		64
Figure 4b – Two-pole circuit-breaker with two protected poles.....		64
Figure 5 – Three-pole circuit-breaker (or three single-pole circuit-breakers).....		65
Figure 6 – Four-pole circuit-breaker .....		65
Figure 3 to 6 – Test circuits for short-circuit tests .....		65
Figure 7 – Example of short-circuit making or breaking test record in the case of a single-pole device on single phase a c. ....		66
Figure 8 – Mechanical shock test apparatus (9.13.1) .....		67
Figure 9 – Standard test finger (9.6).....		68
Figure 10 – Mechanical impact test apparatus (9.13.2) .....		69
Figure 11 – Striking element for pendulum for mechanical impact test apparatus (9.13.2) .....		70

Figure 12 – Mounting support for mechanical impact test (9.13.2)	71
Figure 13 – Example of mounting for a rear fixed circuit-breaker for mechanical impact test (9.13.2)	72
Figure 14 – Example of mounting of a panel board type circuit-breaker for mechanical impact test (9.13.2)	73
Figure 15 – Application of force for mechanical test on a rail-mounted circuit-breaker (9.13.2.3)	74
Figure 16 – Ball-pressure test apparatus	74
Figure 17 – Example of application of force for mechanical test on two-pole plug-in circuit-breaker, the holding in position of which depends solely on the plug-in connections (9.13.2.4)	75
Figures B.1 – Illustrations of the application of the recommendations for creepage distances	78
Figures B.2 – Illustrations of the application of the recommendations for creepage distances	79
Figure D.1 – Overcurrent co-ordination between a circuit-breaker and a fuse or back-up protection by a fuse – Operating characteristics	90
Figure D.2 – Total discrimination between two circuit-breakers	91
Figure D.3 – Back-up protection by a circuit-breaker – Operating characteristics	92
Figure F.1 – Examples of pillar terminals	94
Figure F.2 – Examples of screw terminals and stud terminals	95
Figure F.3 – Examples of saddle terminals	96
Figure F.4 – Examples of lug terminals	96
Figure H.1 – Test arrangement	99
Figure H.2 – Grid circuit	99
Figure H.3 – Grid circuit	100
Figure J.1 – Connecting samples	108
Figure J.2 – Examples of screwless-type terminals	109
Figure K.1 – Example of position of the thermocouple for measurement of the temperature-rise	114
Figure K.2 – Dimensions of male tabs	115
Figure K.3 – Dimensions of round dimple detents (see figure K.2)	116
Figure K.4 – Dimensions of rectangular dimple detents (see figure K.2)	116
Figure K.5 – Dimensions of hole detents	116
Figure K.6 – Dimensions of female connectors	117
Figure L.1 – General arrangement for the test	127
Figure L.2	128
Figure L.3	128
Figure L.4	128
Figure L.5	129
Figure L.6	129
Table 1 – Preferred values of rated voltage	17
Table 2 – Ranges of instantaneous tripping	18
Table 3 – Rated impulse withstand voltage as a function of the nominal voltage of the installation	18
Table 4 – Minimum clearances and creepage distances	23
Table 5 – Connectable cross-sections of copper conductors for screw-type terminals	25
Table 6 – Temperature-rise values	29
Table 7 – Time-current operating characteristics	30

Table 8 – List of type tests .....	32
Table 9 – Cross-sectional areas (S) of test copper conductors corresponding to the rated currents .....	34
Table 10 – Screw thread diameters and applied torques .....	35
Table 11 – Pulling forces .....	36
Table 12 – Conductor dimensions .....	36
Table 13 – Test voltage across the open contacts for verifying the suitability for isolation referred to the rated impulse withstand voltage of the circuit-breaker and to the altitude where the test is carried out .....	40
Table 14 – Test voltage for verification of impulse withstand voltage for the parts not tested in 9.7.6.1 .....	42
Table 15 – Maximum power loss per pole .....	43
Table 16 – Applicability of short-circuit tests .....	47
Table 17 – Power factor ranges of the test circuit .....	50
Table 18 – Ratio $k$ between service short-circuit capacity ( $I_{CS}$ ) and rated short-circuit capacity ( $I_{CN}$ ) .....	54
Table 19 – Test procedure for $I_{CS}$ in the case of single- and two-pole circuit-breakers .....	55
Table 20 – Test procedure for $I_{CS}$ in the case of three- and four-pole circuit-breakers .....	55
Table 21 – Test procedure for $I_{CS}$ in the case of three-phase tests for single-pole circuit-breakers of rated voltage 230/400 V .....	56
Table 22 – The test procedure for $I_{CN}$ .....	56
Table 23 – Test procedure for $I_{CN}$ in the case of three-phase tests for single-pole circuit-breakers of rated voltage 230/400 V .....	57
Table C.1 – Test sequences .....	80
Table C.2 – Number of samples for full test procedure .....	81
Table C.3 – Reduction of samples for series of circuit-breakers having different numbers of poles .....	83
Table C.4 – Test sequences for a series of circuit-breakers being of different instantaneous tripping classifications .....	84
Table J.1 – Connectable conductors .....	105
Table J.2 – Cross-sections of copper conductors connectable to screwless-type terminals .....	105
Table J.3 – Pull forces .....	107
Table K.1 – Informative table on colour code of female connectors in relationship with the cross section of the conductor .....	112
Table K.2 – Overload test forces .....	113
Table K.3 – Dimensions of tabs .....	114
Table K.4 – Dimensions of female connectors .....	117
Table L.1 – Marking for terminals .....	119
Table L.2 – Connectable cross-sections of aluminium conductors for screw-type terminals .....	120
Table L.3 – List of tests according to the material of conductors and terminals .....	121
Table L.4 – Connectable conductors and their theoretical diameters .....	122
Table L.5 – Cross sections (S) of aluminium test conductors corresponding to the rated currents .....	122
Table L.6 – Test conductor length .....	123
Table L.7 – Equalizer and busbar dimensions .....	124
Table L.8 – Test current as a function of rated current .....	126
Table L.9 – Example of calculation for determining the average temperature deviation $D$ .....	126



Low-Voltage Switchgear and Controlgear Sectional Committee, ETD 07

## NATIONAL FOREWORD

This Indian Standard (Part 1) which is identical with IEC 60898-1 : 2002 'Electrical accessories — Circuit-breakers for overcurrent protection for household and similar installations: Part 1 Circuit-breakers for a.c. operation' issued by the International Electrotechnical Commission (IEC) was adopted by the Bureau of Indian Standards on the recommendation of the Low-Voltage Switchgear and Controlgear Sectional Committee and approval of the Electrotechnical Division Council.

This standard is a consolidated version of IEC 60898-1 : 2002 incorporating Amendment Nos. 1 and 2 published in 2002 and 2003 respectively.

This standard supersedes IS 8828 : 1996 'Electrical accessories — Circuit-breakers for overcurrent protection for household and similar installations (*second revision*)'. Other part of the standard is as follows:

### Part 2 Circuit breakers for ac and dc operation

The text of IEC Standard has been approved as suitable for publication as an Indian Standard without deviations. Certain conventions are, however, not identical to those used in Indian Standards. Attention is particularly drawn to the following:

- a) Wherever the words 'International Standard' appear referring to this standard, they should be read as 'Indian Standard'.
- b) Comma (,) has been used as a decimal marker, while in Indian Standards, the current practice is to use a point (.) as the decimal marker.

In this adopted standard, reference appears to certain International Standards for which Indian Standards also exist. The corresponding Indian Standards, which are to be substituted in their respective places, are listed below along with their degree of equivalence for the editions indicated:

<i>International Standard</i>	<i>Corresponding Indian Standard</i>	<i>Degree of Equivalence</i>
IEC 60038 (1983) IEC standard voltages	IS 12360 : 1988 Voltage bands for electrical installations including preferred voltages and frequency	Technically Equivalent
IEC 60050 (441) (1984) International Electrotechnical Vocabulary (IEV) — Chapter 441: Switchgear, controlgear and fuses	IS 1885 (Part 17) : 1979 Electrotechnical vocabulary: Part 17 Switchgear and controlgear ( <i>first revision</i> )	do
IEC 60060-1 (1989) High-voltage test techniques — Part 1: General definitions and test requirements	IS 2071 (Part 1) : 1993 High-voltage test techniques: Part 1 General definitions and test requirements ( <i>second revision</i> )	do
IEC 60112 (1979) Method for determining the comparative and the proof tracking indices of solid insulating materials under moist conditions	IS 2824 : 1975 Method for determining the comparative tracking index of solid insulating materials under moist conditions ( <i>first revision</i> )	do

**IS/IEC 60898-1 : 2002**

<i>International Standard</i>	<i>Corresponding Indian Standard</i>	<i>Degree of Equivalence</i>
IEC 60227 (all parts) Polyvinyl chloride insulated cables of rated voltages up to and including 450/750 V	IS 694 : 1990 PVC Insulated cables for working voltages up to and including 1 100 V ( <i>third revision</i> )	Technically Equivalent
IEC 60269-1 (1986) Low-voltage fuses — Part 1: General requirements	IS 13703 (Part 1) : 1993 Low-voltage fuses for voltages not exceeding 1 000 V ac or 1 500 V dc: Part 1 General requirements	Identical
IEC 60269-2 (1986) Low-voltage fuses —Part 2: Supplementary requirements for fuses for use by authorized persons (fuses mainly for industrial application)	IS 13703 (Part 2/Sec 1) : 1993 Low-voltage fuses for voltages not exceeding 1 000 V ac or 1 500 V dc: Part 2 Fuses for use by authorized persons, Section 1 Supplementary requirements	do
IEC 60269-2-1 (1987) Low-voltage fuses — Part 2-1: Supplementary requirements for fuses for use by authorized persons (fuses mainly for industrial application) — Sections I to V: Examples of types of standardized fuses	IS 13703 (Part 2/Sec 2) : 1993 Low-voltage fuses for voltages not exceeding 1 000 V ac or 1 500 V dc: Part 2 Fuses for use by authorized persons, Section 2 Examples of standardized fuses	do
IEC 60364-4-41 (1992) Electrical installations of buildings — Part 4: Protection for safety — Chapter 41: Protection against electric shock	SP 30 : 1985 National electrical code	Technically Equivalent
IEC 60364-4-47-473 (1977) Electrical installations of buildings — Part 4: Protection for safety — Chapter 47: Application of protective measures for safety — Section 473: Measures of protection against overcurrent		
IEC 60529 Degrees of protection provided by enclosures (IP Code)	IS 12063 : 1987 Classification of degrees of protection provided by enclosures of electrical equipment	do
IEC 60664-1 (2002) <sup>1)</sup> Insulation co-ordination for equipment within low-voltage systems — Part 1: Principles, requirements and tests	IS 15382 (Part 1) : 2003 Insulation coordination for equipment within low-voltage systems: Part 1 Principles, requirements and tests	Identical
IEC 60947-1 (1999) <sup>2)</sup> Low-voltage switchgear and controlgear — Part 1: General rules	IS/IEC 60947-1 : 2004 Low-voltage switchgear and controlgear: Part 1 General rules	Technically Equivalent
IEC 60947-2 (1989) <sup>3)</sup> Low-voltage switchgear and controlgear — Part 2: Circuit-breakers	IS/IEC 60947-2 : 2006 Low-voltage switchgear and controlgear: Part 2 Circuit-breakers	do
IEC 61009-1 (2003) Residual current operated circuit-breakers with integral overcurrent protection for household and similar uses — Part 1: General rules	IS 12640 (Part 2) : 2007 Residual current operated circuit-breakers household and similar uses: Part 2 Circuit-breakers with integral over current protection (RCBOs)	do

<sup>1)</sup> Since revised in 2007.

<sup>2)</sup> Since revised in 2004.

<sup>3)</sup> Since revised in 2006.

The technical committee responsible for the preparation of this standard has reviewed the provisions of the following International Standard referred in this adopted standard and has decided that they are acceptable for use in conjunction with this standard:

<i>International Standard</i>	<i>Title</i>
IEC 60228A : 1982	First supplement to publication 228, Conductors of insulated cables — Guide to the dimensional limits of circular conductors
IEC 60417 (all parts)	Graphical symbols for use on equipment
IEC 60695-2-10	Fire hazard testing — Part 2-10 Glowing/hot-wire based test methods — Glow-wire apparatus and common test procedure
IEC 61545	Connecting devices — Devices for the connection of aluminium conductors in clamping units of any material and copper conductors in aluminium bodies clamping units
IEC 61009-2-1 : 1991	Residual current operated circuit-breakers with integral overcurrent protection for household and similar uses (RCBO's) — Part 2-1: Applicability of the general rules to RCBO's functionally independent of line voltage
IEC 61009-2-2 : 1991	Residual current operated circuit-breakers with integral overcurrent protection for household and similar uses (RCBO's) — Part 2-2: Applicability of the general rules to RCBO's functionally dependent on line voltage
ISO/IEC Guide 2 : 1991	General terms and their definitions concerning standardization and related activities

Only the English text of the International Standard has been retained while adopting it as an Indian Standard, and as such the page numbers given here are not the same as in the IEC Publication.

For the purpose of deciding whether a particular requirement of this standard is complied with, the final value, observed or calculated, expressing the result of a test or analysis, shall be rounded off in accordance with IS 2 : 1960 'Rules for rounding off numerical values (*revised*)'. The number of significant places retained in the rounded off value should be same as that of the specified value in this standard.



*Indian Standard*

**ELECTRICAL ACCESSORIES — CIRCUIT-BREAKERS  
FOR OVERCURRENT PROTECTION FOR  
HOUSEHOLD AND SIMILAR INSTALLATIONS**

**PART 1 CIRCUIT-BREAKERS FOR ac OPERATION**

**1 Scope and object**

This part of IEC 60898 applies to a.c. air-break circuit-breakers for operation at 50 Hz or 60 Hz, having a rated voltage not exceeding 440 V (between phases), a rated current not exceeding 125 A and a rated short-circuit capacity not exceeding 25 000 A.

As far as possible, it is in line with the requirements contained in IEC 60947-2.

These circuit-breakers are intended for the protection against overcurrents of wiring installations of buildings and similar applications; they are designed for use by uninstructed people and for not being maintained.

They are intended for use in an environment with pollution degree 2.

They are suitable for isolation.

Circuit-breakers of this standard, with exception of those rated 120 V or 120/240 V (see table 1), are suitable for use in IT systems provided that the requirements of IEC 60364-4-473:1977 + A1:1998 are complied with.

This standard also applies to circuit-breakers having more than one rated current, provided that the means for changing from one discrete rating to another is not accessible in normal service and that the rating cannot be changed without the use of a tool.

This standard does not apply to

- circuit-breakers intended to protect motors;
- circuit-breakers, the current setting of which is adjustable by means accessible to the user.

For circuit-breakers having a degree of protection higher than IP20 according to IEC 60529, for use in locations where arduous environmental conditions prevail (e.g. excessive humidity, heat or cold or deposition of dust) and in hazardous locations (e.g. where explosions are liable to occur), special constructions may be required.

Requirements for circuit-breakers for a.c. and d.c. operation are given in IEC 60898-2.

Requirements for circuit-breakers which incorporate residual current tripping devices are to be found in IEC 61009-1, IEC 61009-2-1, and IEC 61009-2-2.

A guide for co-ordination under short-circuit conditions between a circuit-breaker and another short-circuit protective device (SCPDs) is given in annex D.

**NOTE 1** For more severe overvoltage conditions, circuit-breakers complying with other standards (e.g. IEC 60947-2) should be used.

**NOTE 2** For an environment with a higher pollution degree, enclosures giving the appropriate degree of protection should be used.

**NOTE 3** Circuit-breakers within the scope of this standard may also be used for protection against electric shock in case of fault, depending on their tripping characteristics and on the characteristics of the installation. The criterion of application for such purposes is dealt with by installation rules.

This standard contains all requirements necessary to ensure compliance with the operational characteristics required for these devices by type tests.

## **IS/IEC 60898-1 : 2002**

It also contains the details relative to test requirements and methods of testing necessary to ensure reproducibility of test results.

This standard states

- a) the characteristics of circuit-breakers;
- b) the conditions with which circuit-breakers shall comply, with reference to:
  - 1) their operation and behaviour in normal service;
  - 2) their operation and behaviour in case of overload;
  - 3) their operation and behaviour in case of short-circuits up to their rated short-circuit capacity;
  - 4) their dielectric properties;
- c) the tests intended for confirming that these conditions have been met and the methods to be adopted for the tests;
- d) the data to be marked on the devices;
- e) the test sequences to be carried out and the number of samples to be submitted for certification purposes (see annex C);
- f) the co-ordination under short-circuit conditions with another short-circuit protective device (SCPD) associated in the same circuit (see annex D);
- g) the routine tests to be carried out on each circuit-breaker to reveal unacceptable variations in material or manufacture, likely to affect safety (see annex I).

## **2 Normative references**

The following referenced documents are indispensable for the application of this document. For dated references, only the edition cited applies. For undated references, the latest edition of the referenced document (including any amendments) applies.

IEC 60038, *IEC standard voltages*

IEC 60050(441), *International Electrotechnical Vocabulary (IEV) – Chapter 441: Switchgear, controlgear and fuses*

IEC 60060-1:1989, *High-voltage test techniques – Part 1: General definitions and test requirements*

IEC 60112, *Method for determining the comparative and the proof tracking indices of solid insulating materials under moist conditions*

IEC 60227 (all parts), *Polyvinyl chloride insulated cables of rated voltages up to and including 450/750 V*

IEC 60228A:1982, First supplement to Publication 228, *Conductors of insulated cables – Guide to the dimensional limits of circular conductors*

IEC 60269 (all parts), *Low-voltage fuses*

IEC 60364 (all parts), *Electrical installations of buildings*

IEC 60364-4-41:1992, *Electrical installations of buildings – Part 4: Protection for safety – Chapter 41: Protection against electric shock*

IEC 60364-4-473:1977, *Electrical installations of buildings – Part 4: Protection for safety – Chapter 47: Application of protective measures for safety – Section 473: Measures of protection against overcurrent*

Amendment 1: 1998

IEC 60417 (all parts), *Graphical symbols for use on equipment*

IEC 60529, *Degrees of protection provided by enclosures (IP Code)*

IEC 60664-1, *Insulation co-ordination for equipment within low-voltage systems – Part 1: Principles, requirements and tests*

IEC 60695-2-10, *Fire hazard testing – Part 2-10: Glowing/hot-wire based test methods – Glow-wire apparatus and common test procedure*

IEC 60947-1:1999, *Low-voltage switchgear and controlgear – Part 1: General rules*

IEC 60947-2:1996, *Low-voltage switchgear and controlgear – Part 2: Circuit-breakers*

IEC 61545, *Connecting devices – Devices for the connection of aluminium conductors in clamping units of any material and copper conductors in aluminium bodied clamping units – Group safety publication*

ISO/IEC Guide 2:1991, *General terms and their definitions concerning standardization and related activities*

### **3 Definitions**

For the purpose of this part of IEC 60898, the definitions given in IEC 60050(441) and the following apply.

#### **3.1 Devices**

##### **3.1.1**

##### **switching device**

a device designed to make or break the current in one or more electric circuits

[IEV 441-14-01]

##### **3.1.2**

##### **mechanical switching device**

a switching device designed to close and open one or more electric circuits by means of separable contacts,

[IEV 441-14-02]

##### **3.1.3**

##### **fuse**

a switching device that, by the melting of one or more of its specially designed and proportioned components, opens the circuit in which it is inserted and breaks the current when this exceeds a given value for a sufficient time

[IEV 441-18-01, modified]

##### **3.1.4**

##### **circuit-breaker (mechanical)**

a mechanical switching device, capable of making, carrying and breaking currents under normal circuit conditions and also making, carrying for a specified time, and automatically breaking currents under specified abnormal circuit conditions such as those of short-circuit

[IEV 441-14-20, modified]

##### **3.1.5**

##### **plug-in circuit-breaker**

a circuit-breaker having one or more plug-in terminals (see 3.3.20) and designed for use with appropriate means for the plug-in connection



**3.2 General terms**

**3.2.1**

**overcurrent**

a current exceeding the rated current

[IEV 441-11-06]

**3.2.2**

**overload current**

overcurrent occurring in an electrically undamaged circuit

NOTE An overload current may cause damage if sustained for a sufficient time.

**3.2.3**

**short-circuit current**

overcurrent resulting from a fault of negligible impedance between points intended to be at different potentials in normal service

NOTE A short-circuit current may result from a fault or from an incorrect connection.

[IEV 441-11-07, modified]

**3.2.4**

**main circuit (of a circuit-breaker)**

all the conductive parts of a circuit-breaker included in the circuit which it is designed to close and open

**3.2.5**

**control circuit (of a circuit-breaker)**

circuit (other than a path of the main circuit) intended for the closing operation or opening operation, or both, of the circuit-breaker

**3.2.6**

**auxiliary circuit (of a circuit-breaker)**

all the conductive parts of a circuit-breaker intended to be included in a circuit other than the main circuit and the control circuit of the circuit-breaker

**3.2.7**

**pole (of a circuit-breaker)**

that part of a circuit-breaker associated exclusively with one electrically separated conducting path of its main circuit provided with contacts intended to connect and disconnect the main circuit itself and excluding those portions which provide a means for mounting and operating the poles together

**3.2.7.1**

**protected pole**

pole provided with an overcurrent release (see 3.3.6)

**3.2.7.2**

**unprotected pole**

pole without overcurrent release (see 3.3.6), but otherwise generally capable of the same performance as a protected pole of the same circuit-breaker

NOTE 1 To ensure compliance with this requirement, the unprotected pole may be of the same construction as the protected pole(s), or of a particular construction.

NOTE 2 If the short-circuit capacity of the unprotected pole is different from that of the protected pole(s), this has to be indicated by the manufacturer.

**3.2.7.3**

**switched neutral pole**

pole only intended to switch the neutral, and not intended to have a short-circuit capacity

**3.2.8**

**closed position**

position in which the predetermined continuity of the main circuit of the circuit-breaker is secured

**3.2.9**

**open position**

position in which the predetermined clearance between open contacts in the main circuit of the circuit-breaker is secured

**3.2.10**

**air temperature**

**3.2.10.1**

**ambient air temperature**

the temperature, determined under prescribed conditions, of the air surrounding the circuit-breaker (for an enclosed circuit-breaker, it is the air outside the enclosure)

[IEV 441-11-13, modified]

**3.2.10.2**

**reference ambient air temperature**

the ambient air temperature on which the time-current characteristics are based

**3.2.11**

**operation**

transfer of the moving contact(s) from the open position to the closed position or vice versa

NOTE If distinction is necessary, an operation in the electrical sense (make or break) is referred to as a "switching operation" and an operation in the mechanical sense (close or open) is referred to as a "mechanical operation".

**3.2.12**

**operating cycle**

succession of operations from one position to another and back to the first position

**3.2.13**

**operation sequence (of a mechanical switching device)**

a succession of specified operations with specified time intervals

[IEV 441-16-03]

**3.2.14**

**uninterrupted duty**

duty in which the main contacts of a circuit-breaker remain closed whilst carrying a steady current without interruption for long periods (which could be weeks, months, or even years)

**3.3 Constructional elements**

**3.3.1**

**main contact**

contact included in the main circuit of a circuit-breaker and intended to carry in the closed position the current of the main circuit

**3.3.2**

**arcing contact**

contact on which the arc is intended to be established

NOTE An arcing contact may serve as a main contact. It may also be a separate contact so designed that it opens after and closes before another contact, which it is intended to protect from damage.

[IEV 441-15-08]

**3.3.3**

**control contact**

contact included in a control circuit of a circuit-breaker and mechanically operated by the circuit-breaker

**3.3.4**

**auxiliary contact**

contact included in an auxiliary circuit and mechanically operated by the circuit-breaker (e.g. for indicating the position of the contacts)

**3.3.5**

**release**

device, mechanically connected to (or integrated into) a circuit-breaker, which releases the holding means and permits the automatic opening of the circuit-breaker

**3.3.6**

**overcurrent release**

release which causes a circuit-breaker to open, with or without time-delay, when the current in the release exceeds a pre-determined value

NOTE In some cases this value can depend upon the rate of rise of current.

**3.3.7**

**inverse time-delay overcurrent release**

overcurrent release which operates after a time-delay inversely dependent upon the value of the overcurrent

NOTE Such a release may be designed so that the time-delay approaches a definite minimum for high values of overcurrent.

**3.3.8**

**direct overcurrent release**

overcurrent release directly energized by the current in the main circuit of a circuit-breaker

**3.3.9**

**overload release**

overcurrent release intended for protection against overloads

**3.3.10**

**conductive part**

part which is capable of conducting current although it may not necessarily be used for carrying current in normal service

**3.3.11**

**exposed conductive part**

conductive part which can be readily touched and which normally is not live, but which may become live under fault conditions

NOTE Typical exposed conductive parts are walls of metal enclosures, metal operating handles, etc.

**3.3.12**

**terminal**

conductive part of a device, provided for re-usable electrical connection to external circuits

**3.3.13**

**screw-type terminal**

terminal for the connection and subsequent disconnection of a conductor or the inter-connection of two or more conductors, capable of being dismantled, the connection being made, directly or indirectly, by means of screws or nuts of any kind

**3.3.14**

**pillar terminal**

screw-type terminal in which the conductor is inserted into a hole or cavity, where it is clamped under the shank of the screw(s). The clamping pressure may be applied directly by the shank of the screw or through an intermediate clamping element to which pressure is applied by the shank of the screw

NOTE Examples of pillar terminals are shown in annex F, figure F.1.

**3.3.15**

**screw terminal**

screw-type terminal in which the conductor is clamped under the head of the screw. The clamping pressure may be applied directly by the head of the screw or through an intermediate part, such as a washer, a clamping plate or an anti-spread device

NOTE Examples of screw terminals are shown in annex F, figure F.2.

**3.3.16**

**stud terminal**

screw-type terminal in which the conductor is clamped under a nut. The clamping pressure may be applied directly by a suitably shaped nut or through an intermediate part, such as a washer, a clamping plate or an anti-spread device

NOTE Examples of stud terminals are shown in annex F, figure F.2.

**3.3.17**

**saddle terminal**

screw-type terminal in which the conductor is clamped under a saddle by means of two or more screws or nuts

NOTE Examples of saddle terminals are shown in annex F, figure F.3.

**3.3.18**

**lug terminal**

screw terminal or stud terminal, designed for clamping a cable lug or a bar by means of a screw or nut

NOTE Examples of lug terminals are shown in annex F, figure F.4.

**3.3.19**

**screwless terminal**

connecting terminal for the connection and subsequent disconnection of one conductor or the interconnection of two or more conductors capable of being dismantled, the connection being made, directly or indirectly, by means of springs, wedges, eccentrics or cones, etc., without special preparation of the conductor other than removal of insulation

**3.3.20**

**plug-in terminal**

terminal the electrical connection and disconnection of which can be effected without displacing the conductors of the corresponding circuit.

The connection is effected without the use of a tool and is provided by the resilience of the fixed and/or moving parts and/or by springs

**3.3.21**

**tapping screw**

screw manufactured from a material having a greater resistance to deformation when applied by rotary insertion to a hole in a material having a lesser resistance to deformation.

The screw is made with a tapered thread, the taper being applied to the core diameter of the thread at the end section of the screw.

The thread produced by application of the screw is formed securely only after sufficient revolutions have been made to exceed the number of threads on the tapered section

**3.3.22**

**thread-forming tapping screw**

tapping screw having an uninterrupted thread. It is not a function of this thread to remove material from the hole

NOTE An example of thread-forming tapping screw is shown in figure 1.

**3.3.23**

**thread-cutting tapping screw**

tapping screw having an interrupted thread. The thread is intended to remove material from the hole.

NOTE An example of thread-cutting tapping screw is shown in figure 2.

**3.4 Conditions of operation**

**3.4.1**

**closing operation**

operation by which the circuit-breaker is brought from the open position to the closed position

**3.4.2**

**opening operation**

operation by which the circuit-breaker is brought from the closed position to the open position

**3.4.3**

**dependent manual operation**

an operation solely by means of directly applied manual energy, such that the speed and force of the operation are dependent upon the action of the operator

[IEV 441-16-13]

**3.4.4**

**independent manual operation**

a stored energy operation where the energy originates from manual power, stored and released in one continuous operation, such that the speed and force of the operation are independent of the action of the operator

[IEV 441-16-16]

**3.4.5**

**trip-free circuit-breaker**

a circuit-breaker, the moving contacts of which return to and remain in the open position when the automatic opening operation is initiated after the initiation of the closing operation, even if the closing command is maintained

NOTE To ensure proper breaking of the current which may have been established, it may be necessary that the contacts momentarily reach the closed position.

**3.5 Characteristic quantities**

Unless otherwise specified, all values of current and voltage are r.m.s. values.

**3.5.1**

**rated value**

stated value of any one of the characteristic quantities that serve to define the working conditions for which the circuit-breaker is designed and built

### 3.5.2

#### **prospective current (of a circuit, and with respect to a circuit-breaker)**

current that would flow in the circuit if each pole of the circuit-breaker were replaced by a conductor of negligible impedance

NOTE The prospective current may be qualified in the same manner as an actual current, for example prospective breaking current, prospective peak current.

[IEV 441-17-01, modified]

### 3.5.3

#### **prospective peak current**

the peak value of a prospective current during the transient period following initiation

NOTE The definition assumes that the current is established by an ideal circuit-breaker, that is, with instantaneous transition from infinite to zero impedance. For circuits where the current can follow several different paths, for example polyphase circuits, it further assumes that the current is established simultaneously in all poles, even if the current in only one pole is considered.

[IEV 441-17-02]

### 3.5.4

#### **maximum prospective peak current (of an a.c. circuit)**

the prospective peak current when the initiation of the current takes place at the instant which leads to the highest possible value

NOTE For a multipole circuit-breaker in a polyphase circuit, the maximum prospective peak current refers to a single pole only.

[IEV 441-17-04]

### 3.5.5

#### **short-circuit (making and breaking) capacity**

alternating component of the prospective current, expressed by its r.m.s. value, which the circuit-breaker is designed to make, to carry for its opening time and to break under specified conditions

#### 3.5.5.1

##### **ultimate short-circuit breaking capacity**

the breaking capacity for which the prescribed conditions according to a specified test sequence do not include the capability of the circuit-breaker to carry 0,85 times its non-tripping current for the conventional time

#### 3.5.5.2

##### **service short-circuit breaking capacity**

the breaking capacity for which the prescribed conditions according to a specified test sequence include the capability of the circuit-breaker to carry 0,85 times its non-tripping current for the conventional time

### 3.5.6

#### **breaking current**

current in a pole of a circuit-breaker at the instant of initiation of the arc during a breaking operation

### 3.5.7

#### **applied voltage**

the voltage which exists across the terminals of a pole of a circuit-breaker just before the making of the current

NOTE This definition refers to a single-pole device. For a multipole device the applied voltage is the voltage across the supply terminals of the device.

### 3.5.8

#### recovery voltage

the voltage which appears across the terminals of a pole of a circuit-breaker after the breaking of the current

NOTE 1 This voltage may be considered as comprising two successive intervals of time, one during which a transient voltage exists, followed by a second one during which power-frequency voltage alone exists.

NOTE 2 This definition refers to a single-pole device. For a multipole device the recovery voltage is the voltage across the supply terminals of the device.

[IEV 441-17-25, modified]

### 3.5.8.1

#### transient recovery voltage

recovery voltage during the time in which it has a significant transient character

NOTE The transient voltage may be oscillatory or non-oscillatory or a combination of these, depending on the characteristics of the circuit and of the circuit-breaker. It includes the voltage shift of the neutral of a polyphase circuit.

[IEV 441-17-26, modified]

### 3.5.8.2

#### power-frequency recovery voltage

recovery voltage after the transient voltage phenomena have subsided

[IEV 441-17-27]

### 3.5.9

#### opening time

time measured from the instant at which, the circuit-breaker being in the closed position, the current in the main circuit reaches the operating value of the overcurrent release to the instant when the arcing contacts have separated in all poles

NOTE The opening time is commonly referred to as tripping time, although, strictly speaking, tripping time applies to the time between the instant of initiation of the opening time and the instant at which the opening command becomes irreversible.

### 3.5.10

#### arcing time

### 3.5.10.1

#### arcing time of a pole

interval of time between the instant of initiation of the arc in a pole and the instant of final arc extinction in that pole

[IEV 441-17-37, modified]

### 3.5.10.2

#### arcing time of a multipole circuit-breaker

interval of time between the instant of first initiation of an arc and the instant of final extinction in all poles

[IEV 441-17-38]

### 3.5.11

#### break time

interval of time between the beginning of the opening time of a circuit-breaker and the end of the arcing time

### 3.5.12

#### $I^2t$ (Joule integral)

integral of the square of the current over a given time interval

$$I^2t = \int_{t_0}^{t_1} i^2 dt$$



**3.5.13**

**$I^2t$  characteristic of a circuit-breaker**

curve giving the maximum values of  $I^2t$  as a function of the prospective current under stated conditions of operation

**3.5.14**

**co-ordination between overcurrent protective devices in series**

**3.5.14.1**

**overcurrent protective co-ordination of overcurrent protective devices**

co-ordination of two or more overcurrent protective devices in series to ensure overcurrent discrimination (selectivity) and/or back-up protection

[IEC 60947-1, definition 2.5.22]

**3.5.14.2**

**overcurrent discrimination**

co-ordination of the operating characteristics of two or more overcurrent protective devices in series such that, on the incidence of overcurrents within stated limits, the device intended to operate within these limits does so, while the other(s) does (do) not

[IEV 441-17-15]

**3.5.14.3**

**back-up protection**

overcurrent co-ordination of two overcurrent protective devices in series, where the protective device, generally but not necessarily on the supply side, effects the overcurrent protection with or without the assistance of the other protective device and prevents excessive stress on the latter

[IEC 60947-1, definition 2.5.24]

**3.5.14.4**

**total discrimination (total selectivity)**

overcurrent discrimination where, in the presence of two overcurrent protective devices in series, the protective device on the load side effects the protection without causing the other protective device to operate

[IEC 60947-2, definition 2.17.2]

**3.5.14.5**

**partial discrimination (partial selectivity)**

overcurrent discrimination where, in the presence of two overcurrent protective devices in series, the protective device on the load side effects the protection up to a given level of overcurrent, without causing the other protective device to operate

[IEC 60947-2, definition 2.17.3]

**3.5.14.6**

**selectivity limit current**

$I_s$

current co-ordinate of the intersection between the total time-current characteristic of the protective device on the load side and the pre-arcing (for fuses), or tripping (for circuit-breakers) time-current characteristic of the other protective device

The selectivity limit current (see figure D.1 of this standard) is a limiting value of current

- below which, in the presence of two overcurrent protective devices in series, the protective device on the load side completes its breaking operation in time to prevent the other protective device from starting its operation (i.e. selectivity is ensured);

## IS/IEC 60898-1 : 2002

- above which, in the presence of two overcurrent protective devices in series, the protective device on the load side may not complete its breaking operation in time to prevent the other protective device from starting its operation (i.e. selectivity is not ensured)

[IEC 60947-2, definition 2.17.4]

### 3.5.14.7

#### **take-over current**

$I_B$

current co-ordinate of the intersection between the time-current characteristics of two overcurrent protective devices

NOTE The take-over current is the current co-ordinate of the intersection between the maximum break-time / current characteristics of two overcurrent protective devices in series.

[IEV 441-17-16]

### 3.5.14.8

#### **conditional short-circuit current (of a circuit or a switching device)**

prospective current that a circuit or a switching device, protected by a specified short-circuit protective device, can satisfactorily withstand for the total operating time of that device under specified conditions of use and behaviour

NOTE 1 For the purpose of this standard, the short-circuit protective device is generally a circuit-breaker or a fuse.

NOTE 2 This definition differs from IEC 441-17-20 by broadening the concept of current limiting device into a short-circuit protective device, the function of which is not only to limit the current.

[IEC 60947-1, definition 2.5.29]

### 3.5.14.9

#### **rated conditional short-circuit current**

$I_{nc}$

value of prospective current, stated by the manufacturer, which the equipment, protected by a short-circuit protective device specified by the manufacturer, can withstand satisfactorily for the operating time of this device under the test conditions in the relevant product standard

[IEC 60947-1, definition 4.3.6.4]

### 3.5.15

#### **conventional non-tripping current**

$I_{nt}$

specified value of current which the circuit-breaker is capable of carrying for a specified time (conventional time) without tripping

### 3.5.16

#### **conventional tripping current**

$I_t$

specified value of current which causes the circuit-breaker to trip within a specified time (conventional time)

### 3.5.17

#### **instantaneous tripping current**

minimum value of current causing the circuit-breaker to operate automatically without intentional time-delay

### 3.6 Definitions related to insulation co-ordination

#### 3.6.1

##### **insulation co-ordination**

mutual correlation of insulation characteristics of electrical equipment taking into account the expected micro-environment and the influencing stresses

[IEC 60664-1, definition 1.3.1]

#### 3.6.2

##### **working voltage**

highest r.m.s. value of the a.c. or d.c. voltage across any particular insulation which can occur when the equipment is supplied at rated voltage

[IEC 60664-1, definition 1.3.5]

NOTE 1 Transients are disregarded.

NOTE 2 Both open-circuit conditions and normal operating conditions are taken into account.

#### 3.6.3

##### **overvoltage**

any voltage having a peak value exceeding the corresponding peak value of maximum steady-state voltage at normal operating conditions

[IEC 60664-1, definition 1.3.7]

#### 3.6.4

##### **impulse withstand voltage**

highest peak value of impulse voltage of prescribed form and polarity, which does not cause breakdown of the insulation under specific conditions

[IEC 60664-1, definition 1.3.8.1]

#### 3.6.5

##### **overvoltage category**

numeral defining a transient overvoltage condition

[IEC 60664-1, definition 1.3.10]

#### 3.6.6

##### **macro-environment**

environment of the room or other location, in which the equipment is installed or used

[IEC 60664-1, definition 1.3.12.1]

#### 3.6.7

##### **micro-environment**

immediate environment of the insulation which particularly influences the dimensioning of the creepage distances

[IEC 60664-1, definition 1.3.12.2]

#### 3.6.8

##### **pollution**

any addition of foreign matter, solid, liquid or gaseous that can result in a reduction of electric strength or surface resistivity of the insulation

[IEC 60664-1, definition 1.3.11]

#### 3.6.9

##### **pollution degree**

numeral characterising the expected pollution of the micro-environment

NOTE The pollution degree to which equipment is exposed may be different from that of the macro-environment where the equipment is located because of protection offered by means such as an enclosure or internal heating to prevent absorption or condensation of moisture.

[IEC 60664-1, definition 1.3.13]

**3.6.10**

**isolation (isolating function)**

function intended to cut off the supply from the whole installation or a discrete section of it by separating it from every source of electrical energy for reasons of safety  
[IEC 60947-1, definition 2.1.19, modified]

**3.6.11**

**isolating distance (of a pole of a mechanical switching device)**

clearance between open contacts, meeting the safety requirements specified for isolation purposes  
[IEV 441-17-35]

**3.6.12**

**clearance**

shortest distance in air between two conductive parts along a string stretched the shortest way between these conductive parts (see annex B)

NOTE For the purpose of determining a clearance to accessible parts, the accessible surface of an insulating enclosure is considered conductive as if it was covered by a metal foil wherever it can be touched by a hand or a standard test finger according to figure 9.

[IEV 441-17-31, modified]

**3.6.13**

**creepage distance**

shortest distance along the surface of an insulating material between two conductive parts (see annex B)

NOTE For the purpose of determining a creepage distance to accessible parts, the accessible surface of an insulating enclosure is considered conductive as if it was covered by a metal foil wherever it can be touched by a hand or a standard test finger according to figure 9.

## **4 Classification**

Circuit-breakers are classified according to several criteria.

### **4.1 According to the number of poles:**

- single-pole circuit-breakers;
- two-pole-circuit-breakers with one protected pole;
- two-pole circuit-breakers with two protected poles;
- three-pole circuit-breakers with three protected poles;
- four-pole circuit-breakers with three protected poles;
- four-pole circuit-breakers with four protected poles.

NOTE The pole which is not a protected pole may be

- "unprotected" (see 3.2.7.2), or
- "switched neutral" (see 3.2.7.3).

### **4.2 According to the protection against external influences:**

- enclosed-type (not requiring an appropriate enclosure);
- unenclosed-type (for use with an appropriate enclosure).

**4.3 According to the method of mounting:**

- surface-type;
- flush-type;
- panel board type, also referred to as distribution board type.

NOTE These types may be intended to be rail mounted.

**4.4 According to the methods of connection**

**4.4.1 According to the fixation system:**

- circuit-breakers, the electrical connections of which are not associated with the mechanical mounting;
- circuit-breakers, the electrical connections of which are associated with the mechanical mounting.

NOTE Examples of this type are:

- plug-in type;
- bolt-on type;
- screw-in type.

Some circuit-breakers may be of the plug-in type or bolt-on type on the line side only, the load terminals being usually suitable for wiring connection.

**4.4.2 According to the type of terminals:**

- circuit-breakers with screw-type terminals for external copper conductors;
- circuit-breakers with screwless type terminals for external copper conductors;  
NOTE 1 The requirements for circuit-breakers equipped with this type of terminals are given in annex J.
- circuit-breakers with flat quick-connect terminals for external copper conductors;  
NOTE 2 The requirements for circuit-breakers equipped with this type of terminals are given in annex K.
- circuit-breakers with screw-type terminals for external aluminium conductors;  
NOTE 3 The requirements for circuit-breakers equipped with this type of terminals are under consideration.

**4.5 According to the instantaneous tripping current (see 3.5.17)**

- B-type;
- C-type;
- D-type.

NOTE The selection of a particular type may depend on the installation rules.

**4.6 According to the  $I^2t$  characteristic**

*In addition to the  $I^2t$  characteristic provided by the manufacturer, circuit-breakers may be classified according to their  $I^2t$  characteristic.*

## 5 Characteristics of circuit-breakers

### 5.1 List of characteristics

*The characteristics of a circuit-breaker shall be stated in the following terms:*

- number of poles (see 4.1);
- protection against external influences (see 4.2);
- method of mounting (see 4.3);
- method of connection (see 4.4);
- value of rated operational voltage (see 5.3.1);
- value of rated current (see 5.3.2);
- value of rated frequency (see 5.3.3);
- range of instantaneous tripping current (see 4.5 and 5.3.5);
- value of rated short-circuit capacity (see 5.3.4);
- $I^2t$  characteristic (see 3.5.13);
- $I^2t$  classification (see 4.6).

### 5.2 Rated quantities

#### 5.2.1 Rated voltages

##### 5.2.1.1 Rated operational voltage ( $U_e$ )

The rated operational voltage (hereinafter referred to as rated voltage) of a circuit-breaker is the value of voltage, assigned by the manufacturer, to which its performance (particularly the short-circuit performance) is referred.

NOTE The same circuit-breaker may be assigned a number of rated voltages and associated rated short-circuit capacities.

##### 5.2.1.2 Rated insulation voltage ( $U_i$ )

The rated insulation voltage of a circuit-breaker is the value of voltage, assigned by the manufacturer, to which dielectric test voltages and creepage distances are referred.

Unless otherwise stated, the rated insulation voltage is the value of the maximum rated voltage of the circuit-breaker. In no case shall the maximum rated voltage exceed the rated insulation voltage.

##### 5.2.1.3 Rated impulse withstand voltage ( $U_{imp}$ )

The rated impulse withstand voltage of a circuit-breaker shall be equal to or higher than the standard values of rated impulse withstand voltage given in table 3.

#### 5.2.2 Rated current ( $I_n$ )

A current assigned by the manufacturer as the current which the circuit-breaker is designed to carry in uninterrupted duty (see 3.2.14), at a specified reference ambient air temperature.

The standard reference ambient air temperature is 30 °C. If a different reference ambient air temperature for the circuit-breaker is used, the effect on the overload protection of cables shall be taken into account, since this is also based on a reference ambient air temperature of 30 °C according to installation rules.

NOTE The reference ambient air temperature for the overload protection of cables has been fixed at 25 °C according to IEC 60364.

**5.2.3 Rated frequency**

The rated frequency of a circuit-breaker is the power frequency for which the circuit-breaker is designed and to which the values of the other characteristics correspond.

The same circuit-breaker may be assigned a number of rated frequencies.

**5.2.4 Rated short-circuit capacity ( $I_{cn}$ )**

The rated short-circuit capacity of a circuit-breaker is the value of the ultimate short-circuit breaking capacity (see 3.5.5.1) assigned to that circuit-breaker by the manufacturer.

NOTE A circuit-breaker having a given rated short-circuit capacity has a corresponding service short-circuit capacity ( $I_{cs}$ ) (see table 18).

**5.3 Standard and preferred values**

**5.3.1 Preferred values of rated voltage**

Preferred values of rated voltage are given in table 1.

**Table 1 – Preferred values of rated voltage**

Circuit-breakers	Circuit supplying the circuit-breaker	Rated voltage of circuit-breakers for use in systems 230 V, 230/400 V, 400 V	Rated voltage of circuit-breakers for use in systems 120/240V, 240 V
		V	V
Single pole	Single phase (phase to neutral or phase to phase)	230	
	Three-phase-4-wire	230	
	Single phase (phase to earthed middle conductor, or phase to neutral)		120
	Single phase (phase to neutral) or three-phase, using three single-pole circuit-breakers (3-wire or 4-wire)	230/400	
Two-pole	Single phase (phase to neutral or phase to phase)	230	
	Single phase (phase to phase)	400	240
	Single phase (phase to phase, 3-wire)		120/240
	Three phase (4-wire)	230	
Three-pole	Three phase (3-wire or 4-wire)	400	240
Four-pole	Three phase (4-wire)	400	

NOTE 1 In IEC 60038 the network voltage value of 230/400 V has been standardized. This value should progressively supersede the values of 220/380V and 240/415 V.

NOTE 2 Wherever in this standard there is a reference to 230 V or 400 V, they may be read as 220 V or 240 V, 380 V or 415 V, respectively.

NOTE 3 Wherever in this standard there is a reference to 120 V or 120/240 V, they may be read as 100 V or 100/200 V, respectively.

**5.3.2 Preferred values of rated current**

Preferred values of rated current are:

6 A, 8 A, 10 A, 13 A, 16 A, 20 A, 25 A, 32 A, 40 A, 50 A, 63 A, 80 A, 100 A and 125 A.



# IS/IEC 60898-1 : 2002

## 5.3.3 Standard values of rated frequency

Standard values of rated frequency are 50 Hz and 60 Hz.

## 5.3.4 Standard values of rated short-circuit capacity

### 5.3.4.1 Standard values up to and including 10 000 A

Standard values of rated short-circuit capacities up to and including 10 000 A are:

1 500 A, 3 000 A, 4 500 A, 6 000 A, 10 000 A.

NOTE The values of 1 000 A, 2 000 A, 2 500 A, 5 000 A, 7 500 A and 9 000 A are also considered as standard in some countries.

The corresponding power factor ranges are given in 9.12.5.

### 5.3.4.2 Values above 10 000 A up to and including 25 000 A

For values above 10 000 A up to and including 25 000 A the preferred value is 20 000 A.

The corresponding power factor range is given in 9.12.5.

## 5.3.5 Standard ranges of instantaneous tripping

Standard ranges of instantaneous tripping are given in table 2.

**Table 2 – Ranges of instantaneous tripping**

Type	Range
B	Above $3 I_n$ up to and including $5 I_n$
C	Above $5 I_n$ up to and including $10 I_n$
D	Above $10 I_n$ up to and including $20 I_n$ <sup>a</sup>

<sup>a</sup> For special cases values up to  $50 I_n$  may also be used.

## 5.3.6 Standard values of rated impulse withstand voltage ( $U_{imp}$ )

Table 3 gives the standard values of rated impulse withstand voltages as a function of the nominal voltage of the installation.

**Table 3 – Rated impulse withstand voltage as a function of the nominal voltage of the installation**

Rated impulse withstand voltage $U_{imp}$ kV	Nominal voltage of the installation	
	Three-phase systems V	Single-phase system with mid-point earthed V
2,5 <sup>a</sup>		120/240 <sup>b</sup>
4 <sup>a</sup>	230/400, 250/440	120/240, 240 <sup>c</sup>

NOTE 1 For test voltages to check the insulation, see table 14.

NOTE 2 For test voltages to check the isolation distance across open contacts, see table 13.

<sup>a</sup> The values 3 kV and 5 kV respectively are used for verifying the isolating distances across open contacts at the altitude of 2 000 m (see tables 4 and 13).

<sup>b</sup> For installation practice in Japan.

<sup>c</sup> For installation practice in North American countries.

## 6 Marking and other product information

Each circuit-breaker shall be marked in a durable manner with the following

- a) manufacturer's name or trade mark;
- b) type designation, catalogue number or serial number;
- c) rated voltage(s);
- d) rated current without symbol "A", preceded by the symbol of instantaneous tripping (B, C or D), for example B 16;
- e) rated frequency if the circuit-breaker is designed only for one frequency (see 5.3.3);
- f) rated short-circuit capacity, in amperes;
- g) wiring diagram, unless the correct mode of connection is evident;
- h) reference ambient air temperature, if different from 30 °C;
- i) degree of protection (only if different from IP20);
- j) for type D circuit-breakers: the maximum instantaneous tripping current, if higher than  $20 I_n$  (see table 2);
- k) rated impulse withstand voltage  $U_{imp}$  if it is 2,5 kV.

Marking d) shall be readily visible when the circuit-breaker is installed. If, for small devices, the available space is insufficient, markings a), b), c), e), f), h), i) and j) may be put on the side or on the back of the circuit-breaker. Marking g) may be on the inside of any cover which has to be removed in order to connect the supply wires but shall not be on a label loosely attached to the circuit-breaker. Any other information not marked shall be given in the manufacturer's documentation.

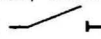
The suitability for isolation, which is provided by all circuit-breakers of this standard, may be indicated by the symbol  on the device. When affixed, this marking may be included in a wiring diagram, where it may be combined with symbols of other functions, e.g. overload protection, or other symbols of technical committee 3 of IEC 1. When the symbol is used on its own (i.e. not in a wiring diagram), combination with symbols of other functions is not allowed.

NOTE 1 In the following countries: DK, FI, NO, SE and ZA the marking of the symbol on the circuit-breaker is mandatory to indicate that the device provides isolation for the installation downstream. In these countries it is required that the symbol be clearly and unmistakably visible when the circuit-breaker is installed as in service and the actuator is accessible.

NOTE 2 In Australia this marking on the circuit-breaker is mandatory but is not required to be visible after installation.

If a degree of protection higher than IP20 according to IEC 60529 is marked on the device, it shall comply with it, whichever the method of installation. If the higher degree of protection is obtained only by a specific method of installation and/or with the use of specific accessories (e.g. terminal covers, enclosures, etc.), this shall be specified in the manufacturer's literature.

The manufacturer shall make available, on request, the  $I^2t$  characteristic (see 3.5.13).

The manufacturer may indicate the  $I^2t$  classification (see 4.6) and mark the circuit-breakers accordingly.

For circuit-breakers other than those operated by means of push-buttons the open position shall be indicated by the symbol O (a circle) and the closed position by the symbol I (a short vertical straight line). Additional national symbols for this indication are allowed. Provisionally the use of this national indication alone is allowed. These indications shall be readily visible when the circuit-breaker is installed.

For circuit-breakers operated by means of two push-buttons, only the push-button designed for the opening operation shall be red and/or be marked with the symbol O.

Red shall not be used for any other push-button of the circuit-breaker.

<sup>1</sup> IEC technical committee 3: Documentation and graphical symbols.

## IS/IEC 60898-1 : 2002

If a push-button is used for closing the contacts and is clearly identified as such, its depressed position is sufficient to indicate the closed position.

If a single push-button is used for closing and opening the contacts and is identified as such, the button remaining in its depressed position is sufficient to indicate the closed position. On the other hand, if the button does not remain depressed, an additional means indicating the position of the contacts shall be provided.

For circuit-breakers with multiple current ratings, the maximum value shall be marked in accordance with marking d), and in addition the value for which the circuit-breaker is adjusted shall be indicated without ambiguity.

If it is necessary to distinguish between the supply and the load terminals, the former shall be indicated by arrows pointing towards the circuit-breaker and the latter by arrows pointing away from the circuit-breaker.

Terminals intended exclusively for the neutral shall be indicated by the letter N.

*Terminals intended for the protective conductor, if any, shall be indicated by the symbol*  
 (IEC 60417-5019).

NOTE 3 The symbol  (IEC 60417-5017), previously recommended, will be progressively superseded by the preferred symbol IEC 60417-5019 given above.

Marking shall be indelible and easily legible, and shall not be placed on screws, washers or other removable parts.

*Compliance is checked by inspection and by the test of 9.3.*

## 7 Standard conditions for operation in service

Circuit-breakers complying with this standard shall be capable of operating under the following standard conditions.

### 7.1 Ambient air temperature range

The ambient air temperature does not exceed +40 °C and its average over a period of 24 h does not exceed +35 °C.

The lower limit of the ambient air temperature is -5 °C.

Circuit-breakers intended to be used in ambient air temperatures above +40 °C (particularly in tropical countries) or below -5 °C shall either be specially designed or be used according to the information given in the manufacturer's catalogue.

### 7.2 Altitude

In general the altitude of the site of installation does not exceed 2 000 m (6 600 ft).

For installations at higher altitudes, it is necessary to take into account the reduction of the dielectric strength and of the cooling effect of the air. Circuit-breakers intended to be so used shall be designed specially or used according to an agreement between manufacturer and user. Information given in the manufacturer's catalogue may take the place of such an agreement.

### 7.3 Atmospheric conditions

The air is clean and its relative humidity does not exceed 50 % at a maximum temperature of +40 °C.

Higher relative humidities may be permitted at lower temperatures, for example 90 % at +20 °C.

Care should be taken by appropriate means (for example drain holes) of moderate condensation which may occasionally occur due to variations in temperature.

#### **7.4 Conditions of installation**

The circuit-breaker shall be installed in accordance with the manufacturer's instructions.

#### **7.5 Pollution degree**

Circuit-breakers to this standard are intended for environment with pollution degree 2, i.e. normally only non-conductive pollution occurs; occasionally, however, a temporary conductivity caused by condensation may be expected.

### **8 Requirements for construction and operation**

#### **8.1 Mechanical design**

##### **8.1.1 General**

Circuit-breakers shall be so designed and constructed that, in normal use, their performance is reliable and without danger to the user or surroundings.

*In general, compliance is checked by carrying out all the relevant tests specified.*

##### **8.1.2 Mechanism**

The moving contacts of all poles of multipole circuit-breakers shall be so mechanically coupled that all poles, except the switched neutral, if any, make and break substantially together, whether operated manually or automatically, even if an overload occurs on one protected pole only.

The switched neutral pole (see 3.2.7.3) of four-pole circuit-breakers shall not close after and shall not open before the protected poles.

*Compliance is checked by inspection and by manual test, using any appropriate means (e.g. indicator lights, oscilloscope, etc.).*

If a pole having an appropriate short-circuit making and breaking capacity is used as a neutral pole and the circuit-breaker has an independent manual operation (see 3.4.4), then all poles, including the neutral pole, may operate substantially together.

Circuit-breakers shall have a trip-free mechanism.

It shall be possible to switch the circuit-breaker on and off by hand. For plug-in type circuit-breakers without operating handle, this requirement is not considered met by the fact that the circuit-breaker can be removed from its base.

Circuit-breakers shall be so constructed that the moving contacts can come to rest only in the closed position (see 3.2.8) or in the open position (see 3.2.9), even when the operating means is released in an intermediate position.

Circuit-breakers shall provide in the open position (see 3.2.9) an isolation distance in accordance with the requirements necessary to satisfy the isolating function (see 8.3). Indication of the open and closed position of the main contacts shall be provided by one or both of the following means:

- the position of the actuator (this being preferred), or
- a separate mechanical indicator.

## **IS/IEC 60898-1 : 2002**

If a separate mechanical indicator is used to indicate the position of the main contacts, this shall show the colour red for the closed position (ON) and the colour green for the open position (OFF).

The means of indication of the contact position shall be reliable.

*Compliance is checked by inspection and by the tests of 9.10.2.*

Circuit-breakers shall be designed so that the actuator, front plate or cover can only be correctly fitted in a manner which ensures correct indication of the contact position.

*Compliance is checked by inspection and by the tests of 9.12.12.1 and 9.12.12.2.*

Where the operating means is used to indicate the position of the contacts, the operating means, when released, shall automatically take up the position corresponding to that of the moving contact(s); in this case, the operating means shall have two distinct rest positions corresponding to the position of the contacts but, for automatic opening, a third distinct position of the operating means may be provided.

The action of the mechanism shall not be influenced by the position of enclosures or covers and shall be independent of any removable part.

A cover sealed in position by the manufacturer is considered to be a non-removable part.

If the cover is used as a guiding means for push-buttons, it shall not be possible to remove the buttons from the outside of the circuit-breaker.

Operating means shall be securely fixed on their shafts and it shall not be possible to remove them without the aid of a tool. Operating means directly fixed to covers are allowed.

If the operating means has an "up-down" movement, when the circuit-breaker is mounted as in normal use, the contacts shall be closed by the up movement.

**NOTE 1** Provisionally in certain countries down-closing movement is allowed.

*Compliance is checked by inspection and by manual test.*

When means are provided or specified by the manufacturer to lock the operating means in the open position, locking in that position shall only be possible when the main contacts are in the open position.

**NOTE 2** Locking of the operating means in the closed position is permitted for particular applications.

*Compliance is checked by inspection, taking into account the instructions of the manufacturer.*

### **8.1.3 Clearances and creepage distances (see annex B)**

The minimum required clearances and creepage distances are given in table 4 which is based on the circuit-breaker being designed for operating in an environment with degree of pollution 2. However, the clearances of items 2, 4 and 5 may be reduced provided that the tests at rated impulse voltage are withstood.

The insulating materials are classified into material groups on the basis of their comparative tracking index (CTI) according to 2.7.1.1 and 2.7.1.3 of IEC 60664-1.

Table 4 – Minimum clearances and creepage distances

	Minimum clearances mm			Minimum creepage distances <sup>a, f</sup> mm											
				Group IIIa <sup>h</sup> (175 V ≤ CTI < 400 V)				Group II (400 V ≤ CTI < 600 V) <sup>d</sup>				Group I (600 V ≤ CTI) <sup>e</sup>			
	Rated voltage V			Working voltage <sup>g</sup> V											
	U <sub>imp</sub>														
	2,5 kV	4 kV	4 kV												
Description	120/240 120	120/240 240	230/400 230 400	>25 ≤50 <sup>i</sup>	120	250	400	>25 ≤50 <sup>i</sup>	120	250	400	>25 ≤50 <sup>i</sup>	120	250	400
1. between live parts which are separated when the main contacts are in the open position <sup>a</sup>	2,0	4,0	4,0	1,2	2,0	4,0	4,0	0,9	2,0	4,0	4,0	0,6	2,0	4,0	4,0
2. between live parts of different polarity <sup>a</sup>	1,5	3,0	3,0	1,2	1,5	3,0	4,0	0,9	1,5	3,0	3,0	0,8	1,5	3,0	3,0
3. between circuits supplied from different sources, one of which being PELV or SELV <sup>g</sup>	3,0	6,0	8,0		3,0	6,0	8,0		3,0	6,0	8,0		3,0	6,0	8,0
				Rated voltage V											
				120 / 240	230 / 400	120 / 240	230 / 400	120 / 240	230 / 400	120 / 240	230 / 400	120 / 240	230 / 400	120 / 240	230 / 400
4. between live parts and – accessible surfaces of operating means – screws or other means for fixing covers which have to be removed when mounting the circuit-breaker – surface on which the circuit-breaker is mounted <sup>b</sup> – screws or other means for fixing the circuit-breaker <sup>b</sup> – metal covers or boxes <sup>b</sup> – other accessible metal parts <sup>c</sup> – metal frames supporting flush-type circuit-breakers	1,5	3,0	3,0	1,5	4,0	1,5	3,0	1,5	3,0	1,5	3,0	1,5	3,0	1,5	3,0
5. between metal parts of the mechanism and – accessible metal parts <sup>c</sup> – screws or other means for fixing the circuit-breaker – metal frames supporting flush-type circuit breakers															

NOTE 1 The values given for 400 V are also valid for 440 V.

NOTE 2 The parts of the neutral path, if any, are considered to be live parts.

NOTE 3 Dimensioning rules for solid insulation are under consideration.

NOTE 4 Care should be taken to provide adequate clearances and creepage distances between live parts of different polarity of circuit-breakers, e.g. of the plug-in type mounted close to one another.

a For auxiliary and control contacts the values are given in the relevant standard.

b The values are doubled if clearances and creepage distances between live parts of the device and the metallic screen or the surface on which the circuit-breaker is mounted are not dependent on the design of the circuit-breaker only, so that they can be reduced when the circuit-breaker is mounted in the most unfavourable condition.

c Including a metal foil in contact with the surfaces of insulating material which are accessible after installation for normal use. The foil is pushed into corners, grooves, etc., by means of a straight unjointed test finger according to 9.6 (see figure 9).

d See IEC 60112.

e Interpolation is allowed in determining creepage distances corresponding to voltage values intermediate to those listed as working voltage. For determination of creepage distances see annex B.

f Creepage distances cannot be less than the associated clearances.

g To cover all different voltages including ELV in an auxiliary contact.

h For material group IIIb ( $100\text{ V} \leq \text{CTI} < 175\text{ V}$ ) the values for material group IIIa multiplied by 1,6 apply.

i For working voltages up to and including 25 V reference may be made to IEC 60664-1.

### 8.1.4 Screws, current-carrying parts and connections

8.1.4.1 Connections, whether electrical or mechanical, shall withstand the mechanical stresses occurring in normal use.

Screws operated when mounting the circuit-breaker during installation shall not be of the thread-cutting type.

NOTE 1 Screws (or nuts) which are operated when mounting the circuit-breaker include screws for fixing covers or cover-plates, but not connecting means for screwed conduits and for fixing the base of a circuit-breaker.

*Compliance is checked by inspection and by the test of 9.4.*

NOTE 2 Screwed connections are considered as checked by the tests of 9.8, 9.9, 9.12, 9.13 and 9.14.

8.1.4.2 For screws in engagement with a thread of insulating material and which are operated when mounting the circuit-breaker during installation, correct introduction of the screw into the screw hole or nut shall be ensured.

*Compliance is checked by inspection and by manual test.*

NOTE The requirement with regard to correct introduction is met, if introduction of the screw in a slanting manner is prevented, for example by guiding the screw by the part to be fixed by a recess in the female thread, or by the use of a screw with the leading thread removed.

8.1.4.3 Electrical connections shall be so designed that contact pressure is not transmitted through insulating material other than ceramic, pure mica or other material with characteristics no less suitable, unless there is sufficient resilience in the metallic parts to compensate for any possible shrinkage or yielding of the insulating material.

*Compliance is checked by inspection.*

NOTE The suitability of the material is considered in respect of the stability of the dimensions.

8.1.4.4 Current-carrying parts and connections including parts intended for protective conductors, if any, shall be of

- copper;
- an alloy containing at least 58 % copper for parts worked cold, or at least 50 % copper for other parts;
- other metal or suitably coated metal, no less resistant to corrosion than copper and having mechanical properties no less suitable.

NOTE New requirements and appropriate tests for determining the resistance to corrosion are under consideration. These requirements should permit other materials to be used if suitably coated.



The requirements of this subclause do not apply to contacts, magnetic circuits, heater elements, bimetal, current-limiting materials, shunts, parts of electronic devices nor to screws, nuts, washers, clamping plates and similar parts of terminals.

**8.1.5 Terminals for external conductors**

**8.1.5.1** Terminals for external conductors shall be such that the conductors may be connected so as to ensure that the necessary contact pressure is maintained permanently.

Connection arrangements intended for busbar connection are admissible, provided they are not used for the connection of cables.

Such arrangements may be either of the plug-in or of the bolt-on type.

The terminals shall be readily accessible under the intended conditions of use.

*Compliance is checked by inspection, by the tests of 9.5 for screw-type terminals, by specific tests for plug-in or bolt-on circuit-breakers included in the standard, or by the tests of annex J or K, as relevant for the type of connection.*

**8.1.5.2** Circuit-breakers shall be provided with terminals which shall allow the connection of copper conductors having nominal cross-sectional areas as shown in table 5.

NOTE 1 Examples of possible designs of screw-type terminals are given in annex F.

*Compliance is checked by inspection, by measurement and by fitting in turn one conductor of the smallest and one of the largest cross-sectional area as specified.*

**Table 5 – Connectable cross-sections of copper conductors for screw-type terminals**

Rated current <sup>a</sup> A	Range of nominal cross-sections to be clamped mm <sup>2</sup>
Up to and including 13	1 to 2,5
above 13 up to and including 16	1 to 4
above 16 up to and including 25	1,5 to 6
above 25 up to and including 32	2,5 to 10
above 32 up to and including 50	4 to 16
above 50 up to and including 80	10 to 25
above 80 up to and including 100	16 to 35
above 100 up to and including 125	25 to 50
<sup>a</sup> It is required that, for current ratings up to and including 50 A, terminals be designed to clamp solid conductors as well as rigid stranded conductors; the use of flexible conductors is permitted.  Nevertheless, it is permitted that terminals for conductors having cross-sections from 1 mm <sup>2</sup> up to 6 mm <sup>2</sup> be designed to clamp solid conductors only.	

NOTE 2 For AWG copper conductors see annex G.

## **IS/IEC 60898-1 : 2002**

**8.1.5.3** The means for clamping the conductors in the terminals shall not serve to fix any other component, although they may hold the terminals in place or prevent them from turning.

*Compliance is checked by inspection and by the tests of 9.5.*

**8.1.5.4** Terminals for rated currents up to and including 32 A shall allow the conductors to be connected without special preparation.

*Compliance is checked by inspection.*

**NOTE** The term "special preparation" covers soldering of the wire of the conductor, use of cable lugs, formation of eyelets, etc., but not the reshaping of the conductor before its introduction into the terminal or the twisting of a flexible conductor to consolidate the end.

**8.1.5.5** Terminals shall have adequate mechanical strength. Screws and nuts for clamping the conductors shall have a metric ISO thread or a thread comparable in pitch and mechanical strength.

*Compliance is checked by inspection and by the tests of 9.4 and 9.5.1.*

**NOTE** Provisionally, SI, BA and UN threads may be used as they are virtually equivalent in pitch and mechanical strength to metric ISO threads.

**8.1.5.6** Terminals shall be so designed that they clamp the conductor without undue damage to the conductor.

*Compliance is checked by inspection and by the test of 9.5.2.*

**8.1.5.7** Terminals shall be so designed that they clamp the conductor reliably and between metal surfaces.

*Compliance is checked by inspection and by the tests of 9.4 and 9.5.1.*

**8.1.5.8** Terminals shall be so designed or positioned that neither a rigid solid conductor nor a wire of a stranded conductor can slip out while the clamping screws or nuts are tightened.

This requirement does not apply to lug terminals.

*Compliance is checked by the test of 9.5.3.*

**8.1.5.9** Terminals shall be so fixed or located that, when the clamping screws or nuts are tightened or loosened, the terminals shall not work loose from their fixings to circuit-breakers.

**NOTE 1** These requirements do not imply that the terminals shall be so designed that their rotation or displacement is prevented, but any movement must be sufficiently limited so as to prevent non-compliance with the requirements of this standard.

**NOTE 2** The use of sealing compound or resin is considered to be sufficient for preventing a terminal from working loose, provided that

- the sealing compound or resin is not subject to stress during normal use, and
- the effectiveness of the sealing compound or resin is not impaired by temperatures attained by the terminal under the most unfavourable conditions specified in this standard.

*Compliance is checked by inspection, by measurement and by the test of 9.4.*

**8.1.5.10** Clamping screws or nuts of terminals intended for the connection of protective conductors shall be adequately secured against accidental loosening.

*Compliance is checked by manual test.*

NOTE In general, the designs of terminals (examples of which are shown in annex F) provide sufficient resilience to comply with this requirement; for other designs, special provisions, such as the use of an adequately resilient part which is not likely to be removed inadvertently, may be necessary.

**8.1.5.11** Pillar terminals shall allow full insertion and reliable clamping of the conductor

*Compliance is checked by inspection after a solid conductor of the largest cross-sectional area specified for the relevant rated current in table 5 has been fully inserted and fully clamped by applying the torques according to table 10.*

**8.1.5.12** Screws and nuts of terminals intended for the connection of external conductors shall be in engagement with a metal thread and the screws shall not be of the tapping screw type.

## **8.1.6 Non-interchangeability**

For circuit-breakers intended to be mounted on bases forming a unit therewith (plug-in type or screw-in type) it shall not be possible, without the aid of a tool, to replace a circuit-breaker when mounted and wired as for normal use by another of the same make having a higher rated current.

*Compliance is checked by inspection.*

NOTE The expression "as for normal use" implies that the circuit-breaker is installed according to the manufacturer's instructions.

## **8.1.7 Mechanical mounting of plug-in type circuit-breakers**

The mechanical mounting of plug-in type circuit-breakers, the holding in position of which does not depend solely on their plug-in connection(s), shall be reliable and have adequate stability.

**8.1.7.1 Plug-in type circuit-breakers, the holding in position of which does not depend solely on their plug-in connection(s)**

*Compliance of the mechanical mounting is checked by the relevant tests of 9.13.*

**8.1.7.2 Plug-in type circuit-breakers, the holding in position of which depends solely on their plug-in connection(s)**

*Compliance of the mechanical mounting is checked by the relevant tests of 9.13.*

## **8.2 Protection against electric shock**

Circuit-breakers shall be so designed that, when they are mounted and wired as for normal use (see note to 8.1.6), live parts are not accessible.

A part is considered to be "accessible" if it can be touched by the test finger (see 9.6).

## **IS/IEC 60898-1 : 2002**

For circuit-breakers other than those of the plug-in type, external parts, other than screws or other means for fixing covers and labels, which are accessible when the circuit-breakers are mounted and wired as for normal use, shall either be of insulating material or be lined throughout with insulating material, unless the live parts are within an internal enclosure of insulating material.

Linings shall be fixed in such a way that they are not likely to be lost during installation of the circuit-breakers. They shall have adequate thickness and mechanical strength and shall provide adequate protection at places where sharp edges occur.

Inlet openings for cables or conduits shall either be of insulating material or be provided with bushings or similar devices of insulating material. Such devices shall be reliably fixed and shall have adequate mechanical strength.

For plug-in circuit-breakers, external parts other than screws or other means for fixing covers, which are accessible in normal conditions of use, shall be of insulating material.

Metallic operating means shall be insulated from live parts and their exposed conductive parts shall be covered by insulating material. This requirement does not apply to means for coupling insulated operating means of several poles. Metal parts of the mechanism shall not be accessible. In addition, they shall be insulated from accessible metal parts, from metal frames supporting the base of flush-type circuit-breakers, from screws or other means for fixing the base to its support and from a metal plate, if any, used as support.

It shall be possible to replace plug-in circuit-breakers easily without touching live parts.

Lacquer or enamel are not considered to provide adequate insulation for the purpose of this subclause.

*Compliance is checked by inspection and by the test of 9.6.*

### **8.3 Dielectric properties and isolating capability**

Circuit-breakers shall have adequate dielectric properties and shall ensure isolation.

#### **8.3.1 Dielectric strength at power frequency**

Circuit-breakers shall have adequate dielectric properties at power frequency.

*Compliance is checked by the tests of 9.7.1, 9.7.2 and 9.7.3 on the circuit-breaker in new condition.*

*Moreover, after the endurance tests of 9.11 and after the short-circuit tests of 9.12, the circuit-breakers shall withstand the test of 9.7.3 but at the reduced test voltage specified in 9.11.3 and 9.12.12.2 respectively and without the previous humidity treatment of 9.7.1.*

#### **8.3.2 Isolating capability**

Circuit-breakers shall be suitable for isolation.

*Compliance is checked by the verification of compliance with the minimum clearances and creepage distances of item 1 of table 4 and by the tests of 9.7.6.1 and 9.7.6.3.*

### 8.3.3 Dielectric strength at rated impulse withstand voltage ( $U_{imp}$ )

Circuit-breakers shall adequately withstand impulse voltages.

*Compliance is checked by the tests of 9.7.6.2.*

## 8.4 Temperature-rise

### 8.4.1 Temperature-rise limits

The temperature rises of the parts of a circuit-breaker specified in table 6, measured under the conditions specified in 9.8.2, shall not exceed the limiting values stated in that table.

The circuit-breaker shall not suffer damage impairing its functions and its safe use.

**Table 6 – Temperature-rise values**

Parts <sup>a b</sup>	Temperature-rise K
Terminals for external connections <sup>c</sup>	60
External parts liable to be touched during manual operation of the circuit-breaker, including operating means of insulating material and metallic means for coupling insulated operating means of several poles	40
External metallic parts of operating means	25
Other external parts, including that face of the circuit-breaker in direct contact with the mounting surface	60
<sup>a</sup> No value is specified for the contacts, since the design of most circuit-breakers is such that a direct measurement of the temperature of those parts cannot be made without the risk of causing alterations or displacements of parts likely to affect the reproducibility of the tests. The 28-day test (see 9.9) is considered to be sufficient for checking indirectly the behaviour of the contacts with respect to undue overheating in service.	
<sup>b</sup> No value is specified for parts other than those listed, but no damage shall be caused to adjacent parts of insulating materials, and the operation of the circuit-breaker shall not be impaired.	
<sup>c</sup> For plug-in type circuit-breakers, the terminals of the base on which they are installed.	

### 8.4.2 Ambient air temperature

The temperature-rise limits given in table 6 are applicable only if the ambient air temperatures remain between the limits given in 7.1.

## 8.5 Uninterrupted duty

Circuit-breakers shall operate reliably even after long service.

*Compliance is checked by the test of 9.9.*

## 8.6 Automatic operation

### 8.6.1 Standard time-current zone

The tripping characteristic of circuit-breakers shall be such that they ensure adequate protection of the circuit, without premature operation.

The zone of the time-current characteristic (tripping characteristic) of a circuit-breaker is defined by the conditions and the values stated in table 7.

## IS/IEC 60898-1 : 2002

This table refers to a circuit-breaker mounted in accordance with the reference conditions (see 9.2) operating at the reference calibration temperature of 30 °C, with a tolerance of  $^{+5}_{0}$ °C.

Compliance is checked by the tests specified in 9.10.

The test may be made at any convenient temperature, the results being referred to 30 °C, using the information given by the manufacturer.

In any case the variation from the test current of table 7 shall not exceed 1,2 %/ per K of calibration temperature variation.

If the circuit-breakers are marked for a calibration temperature different from 30 °C, they are tested for that different temperature.

The manufacturer shall be prepared to give information on the variation of the tripping characteristic for calibration temperatures differing from the reference value.

**Table 7 – Time-current operating characteristics**

Test	Type	Test current	Initial condition	Limits of tripping or non-tripping time	Result to be obtained	Remarks
a	B, C, D	1,13 $I_n$	Cold <sup>a</sup>	$t \leq 1$ h (for $I_n \leq 63$ A) $t \leq 2$ h (for $I_n > 63$ A)	No tripping	
b	B, C, D	1,45 $I_n$	Immediately following test a	$t < 1$ h (for $I_n \leq 63$ A) $t < 2$ h (for $I_n > 63$ A)	Tripping	Current steadily increased within 5 s
c	B, C, D	2,55 $I_n$	Cold <sup>a</sup>	1 s < $t$ < 60 s (for $I_n \leq 32$ A) 1 s < $t$ < 120 s (for $I_n > 32$ A)	Tripping	
d	B C D	3 $I_n$ 5 $I_n$ 10 $I_n$	Cold <sup>a</sup>	$t \leq 0,1$ s	No tripping	Current established by closing an auxiliary switch
e	B C D	5 $I_n$ 10 $I_n$ 20 $I_n$ <sup>b</sup>	Cold <sup>a</sup>	$t < 0,1$ s	Tripping	Current established by closing an auxiliary switch

NOTE An additional test, intermediate between c and d, is under consideration for circuit-breakers of type D.

<sup>a</sup> The term "cold" means without previous loading, at the reference calibration temperature.

<sup>b</sup> 50  $I_n$  for special cases.

### 8.6.2 Conventional quantities

#### 8.6.2.1 Conventional time

The conventional time is 1 h for circuit-breakers of rated current up to and including 63 A, and 2 h for circuit-breakers of rated current above 63 A.

#### 8.6.2.2 Conventional non-tripping current ( $I_{nt}$ )

The conventional non-tripping current of a circuit-breaker is 1,13 times its rated current.

#### 8.6.2.3 Conventional tripping current ( $I_t$ )

The conventional tripping current of a circuit-breaker is 1,45 times its rated current.

### 8.6.3 Tripping characteristic

The tripping characteristic of circuit-breakers shall be contained within the zone defined in 8.6.1.

NOTE 1 Conditions of temperature and mounting different from those specified in 9.2 (e.g. mounting in a special enclosure, grouping of several circuit-breakers in the same enclosure) may affect the tripping characteristic of circuit-breakers.

NOTE 2 The manufacturer should be prepared to give information on the variation of the tripping characteristic for ambient temperatures differing from the reference value, within the limits of 7.1.

#### 8.6.3.1 Effect of single-pole loading of multipole circuit-breakers on the tripping characteristic

When circuit-breakers having more than one protected pole are loaded on only one of the protected poles, starting from cold, with a current equal to

- 1,1 times the conventional tripping current, for two-pole circuit-breakers with two protected poles,
- 1,2 times the conventional tripping current, for three-pole and four-pole circuit-breakers,

the circuit-breakers shall trip within the conventional time specified in 8.6.2.1.

*Compliance is checked by the test of 9.10.3.*

#### 8.6.3.2 Effect of the ambient air temperature on the tripping characteristic

Ambient temperatures other than the reference temperature, within the limits of  $-5\text{ °C}$  and  $+40\text{ °C}$ , shall not unacceptably affect the tripping characteristic of circuit-breakers.

*Compliance is checked by the tests of 9.10.4.*

### 8.7 Mechanical and electrical endurance

Circuit-breakers shall be capable of performing an adequate number of cycles with rated current.

*Compliance is checked by the test of 9.11.*

### 8.8 Performance at short-circuit currents

Circuit-breakers shall be capable of performing a specified number of short-circuit operations, during which they shall neither endanger the operator nor initiate a flashover between live conductive parts or between live conductive parts and earth.

*Compliance is checked by the tests of 9.12.*



It is required that circuit-breakers be able to make and to break any value of current up to and including the value corresponding to the rated short-circuit capacity at rated frequency, at a power-frequency recovery voltage equal to 105 % ( $\pm 5$  %) of the rated voltage and at any power factor not less than the appropriate lower limit of the range stated in 9.12.5; it is also required that the corresponding values of  $I^2t$  lie below the  $I^2t$  characteristic (see 3.5.13).

**8.9 Resistance to mechanical shock and impact**

Circuit-breakers shall have adequate mechanical behaviour so as to withstand the stresses imposed during installation and use.

*Compliance is checked by the tests of 9.13.*

**8.10 Resistance to heat**

Circuit-breakers shall be sufficiently resistant to heat.

*Compliance is checked by the test of 9.14.*

**8.11 Resistance to abnormal heat and to fire**

External circuit-breaker parts made of insulating material shall not be likely to ignite and to spread fire if current-carrying parts in their vicinity attain a high temperature under fault or overload conditions.

*Compliance is checked by inspection and by the test of 9.15.*

**8.12 Resistance to rusting**

Ferrous parts shall be adequately protected against rusting.

*Compliance is checked by the test of 9.16.*

**9 Tests**

**9.1 Type tests and test sequences**

**9.1.1** *The characteristics of circuit-breakers are verified by means of type tests.*

Type tests required by this standard are listed in table 8.

**Table 8 – List of type tests**

Test	Subclause
<i>Indelibility of marking</i>	9.3
<i>Reliability of screws, current-carrying parts and connections</i>	9.4
<i>Reliability of terminals for external conductors</i>	9.5
<i>Protection against electric shock</i>	9.6
<i>Dielectric properties and isolating capability</i>	9.7
<i>Temperature-rise</i>	9.8
<i>28-day test</i>	9.9
<i>Tripping characteristic</i>	9.10
<i>Mechanical and electrical endurance</i>	9.11
<i>Short-circuit</i>	9.12
<i>Resistance to mechanical shock and impact</i>	9.13
<i>Resistance to heat</i>	9.14
<i>Resistance to abnormal heat and to fire</i>	9.15
<i>Resistance to rusting</i>	9.16

*For the purpose of verification of conformity with the standard, type tests are carried out in test sequences.*

*The test sequences and the number of samples to be submitted are stated in annex C.*

*Unless otherwise specified, each type test (or sequence of type tests) is carried out on circuit-breakers in a clean and new condition.*

NOTE Verification of the conformity to the standards may be made

- by the manufacturer for the purpose of suppliers declaration (13.5.1 of ISO/IEC Guide 2);
- by an independent body for certification (13.5.2 of ISO/IEC Guide 2).

According to the terminology of ISO/IEC Guide 2 the term "certification" can be used for the second case only.

## **9.2 Test conditions**

*The circuit-breaker is mounted individually, vertically and in free air at an ambient temperature between 20 °C and 25 °C, unless otherwise specified, and is protected against undue external heating or cooling.*

*Circuit-breakers designed for installation in an individual enclosure are tested in the smallest of such enclosures specified by the manufacturer.*

*Unless otherwise specified, the circuit-breakers are wired with the appropriate cable specified in table 9 and are fixed on a dull, black-painted plywood board of about 20 mm thickness, the method of fixing complying with any requirements relating to the means of mounting recommended by the manufacturer.*

*Where a tolerance is not specifically specified, type tests are carried out at values not less severe than those specified in this standard.*

*Unless otherwise specified, tests are carried out at the rated frequency  $\pm 5$  Hz and at any convenient voltage.*

*During the tests, no maintenance or dismantling of the samples is allowed.*

*For the tests of 9.8, 9.9, 9.10 and 9.11 the circuit-breaker is connected as follows:*

- a) *The connections are made by means of single-core, PVC insulated copper cables, according to IEC 60227.*
- b) *The tests are carried out with single-phase current, with all poles connected in series, except for the tests of 9.8.2, 9.10.2 and 9.11.*
- c) *The connections are in free air and spaced not less than the distance between the terminals.*
- d) *The minimum length of each temporary connection from terminal to terminal is:*
  - *1 m for cross-sections up to and including 10 mm<sup>2</sup>;*
  - *2 m for cross-sections larger than 10 mm<sup>2</sup>.*

*The tightening torques to be applied to the terminal screws are two-thirds of those specified in table 10.*

**Table 9 – Cross-sectional areas (S) of test copper conductors corresponding to the rated currents**

S mm <sup>2</sup>	Values of the rated current $I_n$ A
1	$I_n \leq 6$
1,5	$6 < I_n \leq 13$
2,5	$13 < I_n \leq 20$
4	$20 < I_n \leq 25$
6	$25 < I_n \leq 32$
10	$32 < I_n \leq 50$
16	$50 < I_n \leq 63$
25	$63 < I_n \leq 80$
35	$80 < I_n \leq 100$
50	$100 < I_n \leq 125$

NOTE For AWG copper conductors see annex G.

### 9.3 Test of indelibility of marking

*The test is made by rubbing the marking by hand for 15 s with a piece of cotton soaked with water and again for 15 s with a piece of cotton soaked with aliphatic solvent hexane with a content of aromatics of maximum 0,1 % by volume, a kauributanol value of 29, an initial boiling-point approximately 65 °C, a dry-point of approximately 69 °C and a density of approximately 0,68 g/cm<sup>3</sup>.*

*Marking made by impression, moulding, or engraving is not subjected to this test.*

*After this test, the marking shall be easily legible.*

*The marking shall also remain easily legible after all the tests of this standard.*

*It shall not be easily possible to remove labels and they shall show no curling.*

### 9.4 Test of reliability of screws, current-carrying parts and connections

*Compliance with the requirements of 8.1.4 is checked by inspection and, for screws and nuts which are operated when mounting and connecting up the circuit-breaker, by the following test.*

*The screws or nuts are tightened and loosened*

- ten times for screws in engagement with a thread of insulating material;*
- five times in all other cases.*

*Screws or nuts in engagement with a thread of insulating material are completely removed and reinserted each time.*

*The test is made by means of a suitable test screwdriver or spanner applying a torque as shown in table 10.*

*The screws and nuts shall not be tightened in jerks.*

*The conductor is moved each time the screw or nut is loosened.*

Plug-in connections are tested by plugging the circuit-breaker in and pulling it out five times.

After the test the connections shall not have become loose nor shall their electrical function be impaired.

**Table 10 – Screw thread diameters and applied torques**

Nominal diameter of thread mm	Torque Nm		
	I	II	III
Up to and including 2,8	0,2	0,4	0,4
over 2,8 up to and including 3,0	0,25	0,5	0,5
over 3,0 up to and including 3,2	0,3	0,6	0,6
over 3,2 up to and including 3,6	0,4	0,8	0,8
over 3,6 up to and including 4,1	0,7	1,2	1,2
over 4,1 up to and including 4,7	0,8	1,8	1,8
over 4,7 up to and including 5,3	0,8	2,0	2,0
over 5,3 up to and including 6,0	1,2	2,5	3,0
over 6,0 up to and including 8,0	2,5	3,5	6,0
over 8,0 up to and including 10,0	–	4,0	10,0

Column I applies to screws without heads if the screw, when tightened, does not protrude from the hole, and to other screws which cannot be tightened by means of a screwdriver with a blade wider than the diameter of the screw.

Column II applies to other screws which are tightened by means of a screwdriver.

Column III applies to screws and nuts which are tightened by means other than a screwdriver.

Where a screw has a hexagonal head with a slot for tightening with a screwdriver and the values in columns II and III are different, the test is made twice, first applying to the hexagonal head the torque specified in column III and then, on another sample, applying the torque specified in column II by means of a screwdriver. If the values in columns II and III are the same, only the test with the screwdriver is made.

During the test, the screwed connections shall not work loose and there shall be no damage, such as breakage of screws or damage to the head slots, threads, washers or stirrups, that will impair the further use of the circuit-breaker.

Moreover, enclosures and covers shall not be damaged.

Plug-in connections are tested by plugging the circuit-breaker in and pulling it out five times.

After the test the connections shall not have become loose nor shall their electrical function be impaired.

## 9.5 Tests of reliability of screw-type terminals for external copper conductors

Compliance with the requirements of 8.1.5 is checked

- by inspection, by the test of 9.4, where a rigid copper conductor having the largest cross-sectional area specified in table 5 is placed in the terminal (for nominal cross-sectional areas exceeding 6 mm<sup>2</sup>, a rigid stranded conductor is used while for other nominal cross-sectional areas, a solid conductor is used);
- by the tests of 9.5.1, 9.5.2 and 9.5.3. These last tests are made by means of a suitable screwdriver or spanner applying a torque as shown in table 10.

**9.5.1** The terminals are fitted with copper conductors of the smallest and largest cross-sectional areas specified in table 5, solid or stranded, whichever is the most unfavourable.

The conductor is inserted into the terminal for the minimum distance prescribed or, where no distance is prescribed, until it just projects from the far side, and in the position most likely to assist the wire to escape.

The clamping screws are then tightened with a torque equal to two-thirds of that shown in the appropriate column of table 10.

Each conductor is then subjected to a pull of the value, in newtons, shown in table 11. The pull is applied without jerks, for 1 min, in the direction of the axis of the conductor space.

**Table 11 – Pulling forces**

<b>Cross-section of the conductor accepted by the terminal mm<sup>2</sup></b>	<b>Up to 4</b>	<b>Up to 6</b>	<b>Up to 10</b>	<b>Up to 16</b>	<b>Up to 50</b>
<b>Pull N</b>	50	60	80	90	100

During the test, the conductor shall not move noticeably in the terminal.

**9.5.2** The terminals are fitted with copper conductors of the smallest and largest cross-sectional areas specified in table 5, solid or stranded, whichever is the most unfavourable, and the terminal screws are tightened with a torque equal to two-thirds of that shown in the appropriate column of table 10. The terminal screws are then loosened and the part of the conductor which may have been affected by the terminal is inspected.

The conductors shall show no undue damage nor severed wires.

NOTE Conductors are considered to be unduly damaged if they show deep and sharp indentations.

During the test, terminals shall not work loose and there shall be no damage, such as breakage of screws or damage to the head slots, threads, washers or stirrups, that will impair the further use of the terminal.

**9.5.3** The terminals are fitted with a rigid stranded copper conductor having the make-up shown in table 12.

**Table 12 – Conductor dimensions**

<b>Range of nominal cross-sections to be clamped mm<sup>2</sup></b>	<b>Stranded conductor</b>	
	<b>Number of wires</b>	<b>Diameter of wires mm</b>
1 to 2,5 <sup>a</sup>	7	0,67
1 to 4 <sup>a</sup>	7	0,85
1,5 to 6 <sup>a</sup>	7	1,04
2,5 to 10	7	1,35
4 to 16	7	1,70
10 to 25	7	2,14
16 to 35	19	1,53
25 to 50	19	1,83

<sup>a</sup> If the terminal is intended to clamp solid conductors only (see table 5), the test is not made.

*Before insertion into the terminal, the wires of the conductors are suitably reshaped.*

*The conductor is inserted into the terminal until the conductor reaches the bottom of the terminal or just projects from the far side of the terminal and in the position most likely to assist a wire to escape. The clamping screw or nut is then tightened with a torque equal to two-thirds of that shown in the appropriate column of table 10.*

*After the test, no wire of the conductor shall have escaped from the clamping unit.*

## **9.6 Test of protection against electric shock**

*The test is made with the standard test finger shown in figure 9, on the sample mounted as for normal use (see note to 8.1.6) and fitted with the conductors of the smallest and largest cross-sectional areas specified in table 5.*

*The standard test finger shall be so designed that each of the jointed sections can be turned through an angle of 90° with respect to the axis of the finger, in the same direction only.*

*The test finger is applied in every possible bending position of a real finger, an electrical contact indicator being used to show contact with live parts.*

*It is recommended that a lamp be used for the indication of contact and that the voltage be not less than 40 V.*

*Circuit-breakers with enclosures or covers of thermoplastic material are subjected to the following additional test, which is carried out at an ambient temperature of 35 °C ± 2 °C, the circuit-breakers being at this temperature.*

*The circuit-breakers are subjected for 1 min to a force of 75 N, applied through the tip of a straight unjointed test finger of the same dimensions as the standard test finger. This finger is applied to all places where yielding of insulating material could impair the safety of the circuit-breaker, but is not applied to knock-outs.*

*During this test, enclosures or covers shall not deform to such an extent that live parts can be touched with the unjointed test finger.*

*Unenclosed circuit-breakers having parts not intended to be covered by an enclosure are submitted to the test with a metal front panel, and mounted as for normal use (see 8.1.6).*

## **9.7 Test of dielectric properties and isolating capability**

### **9.7.1 Resistance to humidity**

#### **9.7.1.1 Preparation of the circuit-breaker for test**

*Inlet openings, if any, are left open; if knock-outs are provided, one of them is opened.*

*Parts which can be removed without the aid of a tool are removed and subjected to the humidity treatment with the main part; spring lids are kept open during this treatment.*

#### **9.7.1.2 Test conditions**

*The humidity treatment is carried out in a humidity cabinet containing air with a relative humidity maintained between 91 % and 95 %.*

*The temperature of the air in which the sample is placed is maintained within ±1 °C of any convenient value T between 20 °C and 30 °C.*

*Before being placed in the humidity cabinet, the sample is brought to a temperature between  $T$  and  $T + 4$  °C.*

### **9.7.1.3 Test procedure**

*The sample is kept in the cabinet for 48 h.*

**NOTE 1** A relative humidity between 91 % and 95 % can be obtained by placing in the humidity cabinet a saturated solution of sodium sulphate ( $\text{Na}_2\text{SO}_4$ ) or potassium nitrate ( $\text{KNO}_3$ ) in water having a sufficiently large contact surface with the air.

**NOTE 2** In order to achieve the specified conditions within the cabinet it is recommended to ensure constant circulation of the air within and, in general, to use a cabinet which is thermally insulated.

### **9.7.1.4 Condition of the circuit-breaker after the test**

*After this treatment, the sample shall show no damage within the meaning of this standard and shall withstand the tests of 9.7.2 and 9.7.3.*

### **9.7.2 Insulation resistance of the main circuit**

*The circuit-breaker is treated as specified in 9.7.1. After an interval between 30 min and 60 min following this treatment, the insulation resistance is measured 5 s after application of a d.c. voltage of approximately 500 V, consecutively as follows:*

- a) with the circuit-breaker in the open position, between each pair of the terminals which are electrically connected together when the circuit-breaker is in the closed position, on each pole in turn;*
  - b) with the circuit-breaker in the closed position, between each pole in turn and the others connected together;*
  - c) with the circuit-breaker in the closed position, between all poles connected together and the frame, including a metal foil in contact with the outer surface of the internal enclosure of insulating material, if any;*
  - d) between metal parts of the mechanism and the frame;*
- NOTE** – For this verification, specially prepared samples may be used.
- e) for circuit-breakers with a metal enclosure having an internal lining of insulating material, between the frame and a metal foil in contact with the inner surface of the lining of insulating material including bushings and similar devices.*

*The measurements a), b) and c) are carried out after having connected all auxiliary circuits to the frame.*

*The term "frame" includes:*

- all accessible metal parts and a metal foil in contact with the surfaces of insulating material which are accessible after installation as for normal use;*
- the surface on which the base of the circuit-breaker is mounted, covered, if necessary, with a metal foil;*
- screws and other devices for fixing the base to its support;*
- screws for fixing covers which have to be removed when mounting the circuit-breaker, and metal parts of operating means referred to in 8.2.*

*If the circuit-breaker is provided with a terminal intended for the interconnection of protective conductors, this terminal is connected to the frame.*

*For the measurements according to items b) to e), the metal foil is applied in such a way that the sealing compound, if any, is effectively tested.*

*The insulation resistance shall be not less than*

- 2 M $\Omega$  for the measurements according to items a) and b);*
- 5 M $\Omega$  for the other measurements.*

### **9.7.3 Dielectric strength of the main circuit**

*After the circuit-breakers have passed the tests of 9.7.2 the test voltage specified in 9.7.5 is applied for 1 min between the parts indicated in 9.7.2.*

*Initially, not more than half the prescribed voltage is applied, then it is raised to the full value within 5 s.*

*No flashover or breakdown shall occur during the test.*

*Glow discharges without drop in the voltage are neglected.*

### **9.7.4 Dielectric strength of the auxiliary and control circuits**

*For these tests, the main circuit shall be connected to the frame. The test voltage specified in 9.7.5 shall be applied for 1 min as follows:*

- a) between all the auxiliary and control circuits, which are not normally connected to the main circuit, connected together, and the frame of the circuit-breaker;*
- b) where appropriate, between each part of the auxiliary and control circuits which may be isolated from the other parts of the auxiliary circuits and these other parts connected together.*

### **9.7.5 Value of test voltage**

*The test voltage shall have practically sinusoidal waveform, and a frequency between 45 Hz and 65 Hz.*

*The source of the test voltage shall be capable of supplying a short-circuit current of at least 0,2 A.*

*No overcurrent tripping device of the transformer shall operate when the current in the output circuit is lower than 100 mA.*

*The values of the test voltage shall be as follows:*

- a) for the main circuit, for auxiliary circuits intended to be connected to the main circuit and for control circuits:
  - 2 000 V for items a) to d) of 9.7.2;*
  - 2 500 V for item e) of 9.7.2;**
- b) for auxiliary and control circuits which are indicated by the manufacturer as unsuitable for connection to the main circuit:
  - 1 000 V, where the rated insulation voltage  $U_i$  does not exceed 60 V;*
  - 2  $U_i$  + 1 000 V, with a minimum of 1 500 V, where the rated insulation voltage  $U_i$  exceeds 60 V.**



**9.7.6 Verification of impulse withstand voltages (across clearances and across solid insulation) and of leakage current across open contacts**

**9.7.6.1 Verification of impulse withstand voltage across the open contacts (suitability for isolation)**

*The test is carried out on a circuit-breaker fixed on a metal support.*

*The impulses are given by a generator producing positive and negative impulses having a front time of 1,2  $\mu$ s, and a time to half-value of 50  $\mu$ s, the tolerances being*

- $\pm 5$  % for the peak value;
- $\pm 30$  % for the front time;
- $\pm 20$  % for the time to half-value.

*The surge impedance of the test apparatus shall have a nominal value of 500  $\Omega$ .*

*The shape of the impulses is adjusted with the circuit-breaker under test connected to the impulse generator. For this purpose appropriate voltage dividers and voltage sensors shall be used.*

*Small oscillations in the impulses are allowed provided that their amplitude near the peak of the impulse is less than 5 % of the peak value.*

*For oscillations on the first half of the front, amplitudes up to 10 % of the peak value are allowed.*

*The 1,2/50  $\mu$ s impulse voltage according to figure 6 of IEC 60060-1 is applied between the line terminals connected together and the load terminals connected together with the contacts in the open position.*

*Three positive impulses and three negative impulses are applied, the interval between consecutive impulses being at least 1 s for impulses of the same polarity and being at least 10 s for impulses of the opposite polarity.*

*The test impulse voltage values shall be chosen in table 13, in accordance with the rated impulse voltage of the circuit-breaker as given in table 3. These values are corrected for barometric pressure and/or altitude at which the tests are carried out, according to table 13.*

*There shall be no unintentional disruptive discharges during the test.*

**Table 13 – Test voltage across the open contacts for verifying the suitability for isolation referred to the rated impulse withstand voltage of the circuit-breaker and to the altitude where the test is carried out**

Rated impulse voltage withstand $U_{imp}$ kV	Test voltages at corresponding altitude				
	$U_{1,2/50}$ a.c. peak kV				
	Sea level	200 m	500 m	1 000 m	2 000 m
2,5	3,5	3,5	3,4	3,2	3,0
4	6,2	6,0	5,8	5,6	5,0

**9.7.6.2 Verification of impulse withstand voltage for the parts not tested in 9.7.6.1**

*The test is carried out on a circuit-breaker fixed on a metal support being in the closed position.*

*The impulses are given by a generator producing positive and negative impulses having a front time of 1,2  $\mu$ s and a time to half value of 50  $\mu$ s the tolerances being*

- $\pm 5$  % for the peak value;*
- $\pm 30$  % for the front time;*
- $\pm 20$  % for the time to half value.*

*The surge impedance of the test apparatus shall have a nominal value of 500  $\Omega$ .*

*The shape of the impulses is adjusted with the circuit-breaker under test connected to the impulse generator. For this purpose appropriate voltage dividers and voltage sensors shall be used.*

**NOTE 1** For circuit-breakers with incorporated surge arresters the shape of the impulses is adjusted without connection of the circuit-breaker to the impulse generator.

*Small oscillations in the impulses are allowed, provided that their amplitude near the peak of the impulse is less than 5 % of the peak value.*

*For oscillations on the first half of the front, amplitudes up to 10 % of the peak value are allowed.*

*A first series of tests is made applying the impulse voltage between the phase pole(s), connected together, and the neutral pole (or path) of the circuit-breaker, as applicable.*

*A second series of tests is made applying the impulse voltage between the metal support connected to the terminal(s) intended for the protective conductor(s), if any, and the phase pole(s) and the neutral pole (or path) connected together.*

*In both cases three positive impulses and three negative impulses are applied, the interval between consecutive impulses being at least 1 s for impulses of the same polarity and at least 10 s for impulses of the opposite polarity.*

*The test impulse voltage values shall be chosen in table 14 in accordance with the rated impulse voltage of the circuit-breaker as given in table 3. These values are corrected for barometric pressure and/or altitude at which the tests are carried out, according to table 14.*

*There shall be no flashover nor unintentional disruptive discharges during the test.*

*If, however, only one such disruptive discharge occurs, six additional impulses having the same polarity as that which caused the disruptive discharge are applied, the connections being the same as those with which the failure occurred.*

*No further disruptive discharge shall occur.*

**NOTE 2** The expression "unintentional disruptive discharge" is used to cover the phenomena associated with the failure of insulation under electric stress, which include a drop in the voltage and the flowing of current.

**Table 14 – Test voltage for verification of impulse withstand voltage for the parts not tested in 9.7.6.1**

Rated impulse withstand voltage $U_{imp}$ kV	Test voltages at corresponding altitude $U_{1,2/50}$ a.c. peak kV				
	Sea level	200 m	500 m	1 000 m	2 000 m
2,5	2,9	2,8	2,8	2,7	2,5
4	4,9	4,8	4,7	4,4	4,0

**9.7.6.3 Verification of leakage currents across open contacts (suitability for isolation)**

*Each pole of circuit-breakers having been submitted to the tests of 9.12.11.2, or 9.12.11.3, or 9.12.11.4.2 or 9.12.11.4.3 is supplied at a voltage 1.1 times its rated operational voltage, the circuit-breaker being in the open position.*

*The leakage current flowing across the open contacts is measured and shall not exceed 2 mA.*

**9.8 Test of temperature-rise and measurement of power loss**

**9.8.1 Ambient air temperature**

*The ambient air temperature shall be measured during the last quarter of the test period by means of at least two thermometers or thermocouples symmetrically positioned around the circuit-breaker at about half its height and at a distance of about 1 m from the circuit-breaker.*

*The thermometers or thermocouples shall be protected against draughts and radiant heat.*

**9.8.2 Test procedure**

*A current equal to  $I_n$  at any convenient voltage is passed simultaneously through all the poles of the circuit-breaker for a period of time sufficient for the temperature-rise to reach the steady-state value or for the conventional time, whichever is the longer.*

*In practice, this condition is reached when the variation of the temperature-rise does not exceed 1 K/h.*

*For four-pole circuit-breakers with three protected poles, the test is first made by passing the specified current through the three protected poles only.*

*The test is then repeated by passing the same current through the pole intended for the connection of the neutral and the adjacent protected pole.*

*During the test, the temperature-rises shall not exceed the values shown in table 6.*

**9.8.3 Measurement of the temperature of parts**

*The temperature of the different parts referred to in table 6 shall be measured by means of fine wire thermocouples or by equivalent means at the nearest accessible position to the hottest spot.*

*Good heat conductivity between the thermocouple and the surface of the part under test shall be ensured.*

#### 9.8.4 Temperature-rise of a part

The temperature-rise of a part is the difference between the temperature of this part measured in accordance with 9.8.3, and the ambient air temperature measured in accordance with 9.8.1.

#### 9.8.5 Measurement of power loss

An a.c. current equal to  $I_n$ , with a supply voltage of a value not less than 30 V, is passed, in a substantially resistive circuit, through each pole of the circuit-breaker.

NOTE 1 A test voltage of a value less than 30 V may be used subject to the manufacturer's agreement.

The power loss per pole, calculated on the basis of the voltage drop measured under steady state conditions between its terminals, shall not exceed the relevant values given in table 15.

NOTE 2 The voltage drop measurement may be made during the temperature-rise test, provided that the test conditions of this subclause are fulfilled.

Table 15 – Maximum power loss per pole

Range of rated current $I_n$	Maximum power loss per pole
A	W
$I_n \leq 10$	3
$10 < I_n \leq 16$	3,5
$16 < I_n \leq 25$	4,5
$25 < I_n \leq 32$	6
$32 < I_n \leq 40$	7,5
$40 < I_n \leq 50$	9
$50 < I_n \leq 63$	13
$63 < I_n \leq 100$	15
$100 < I_n \leq 125$	20

#### 9.9 28-day test

The circuit-breaker is subjected to 28 cycles, each cycle comprising 21 h with a current equal to the rated current at an open circuit voltage of at least 30 V, and 3 h without current under the test conditions of 9.2.

The circuit-breaker is in the closed position, the current being established and interrupted by an auxiliary switch. During this test the circuit-breaker shall not trip.

During the last period of current flow the temperature-rise of the terminals shall be measured.

This temperature-rise shall not exceed the value measured during the temperature-rise test (see 9.8) by more than 15 K.

Immediately after this measurement of the temperature-rise, the current is steadily increased within 5 s to the conventional tripping current.

The circuit-breaker shall trip within the conventional time.

## **IS/IEC 60898-1 : 2002**

### **9.10 Test of tripping characteristic**

*This test is made to verify that the circuit-breaker complies with the requirements of 8.6.1.*

#### **9.10.1 Test of time-current characteristic**

**9.10.1.1** *A current equal to  $1,13 I_n$  (conventional non-tripping current) is passed for the conventional time (see 8.6.1 and 8.6.2.1) through all poles, starting from cold (see table 7).*

*The circuit-breaker shall not trip.*

*The current is then steadily increased within 5 s, to  $1,45 I_n$  (conventional tripping current).*

*The circuit-breaker shall trip within the conventional time.*

**9.10.1.2** *A current equal to  $2,55 I_n$  is passed through all poles, starting from cold.*

*The opening time shall not be less than 1 s and shall not be more than*

- 60 s for rated currents up to and including 32 A;*
- 120 s for rated currents greater than 32 A.*

#### **9.10.2 Test of instantaneous tripping and of correct opening of the contacts**

##### **9.10.2.1 General test conditions**

*For the lower values of the test current of 9.10.2.2, 9.10.2.3 and 9.10.2.4 respectively the test is made once, at any convenient voltage.*

*For the upper values of the test current the test is made at rated voltage  $U_n$  (phase to neutral) with a power factor between 0,95 and 1.*

*The sequence of operation is*

O-t-CO-t-CO-t-CO

*the interval t being as defined in 9.12.11.1.*

*The tripping time of the O operation is measured.*

*After each operation the indicating means shall show the open position of the contacts.*

##### **9.10.2.2 For circuit-breakers of the B-type**

*A current equal to  $3 I_n$  is passed through all poles starting from cold.*

*The opening time shall not be less than 0,1 s.*

*A current equal to  $5 I_n$  is then passed through all poles, again starting from cold.*

*The circuit-breaker shall trip in a time less than 0,1 s.*

**9.10.2.3 For circuit-breakers of the C-type**

*A current equal to  $5 I_n$  is passed through all poles, starting from cold.*

*The opening time shall be not less than 0,1 s.*

*A current equal to  $10 I_n$  is then passed through all poles, again starting from cold.*

*The circuit-breaker shall trip in a time less than 0,1 s.*

**9.10.2.4 For circuit-breakers of the D-type**

*A current equal to  $10 I_n$  is passed through all poles, starting from cold.*

*The opening time shall be not less than 0,1 s.*

*A current equal to  $20 I_n$  or to the maximum instantaneous tripping current (see clause 6, item j) is then passed through all poles, again starting from cold.*

*The circuit-breaker shall trip in a time less than 0,1 s.*

**9.10.3 Test of effect of single-pole loading on the tripping characteristic of multipole circuit-breakers**

*Compliance is checked by testing the circuit-breaker connected in accordance with 9.2, under the conditions specified in 8.6.3.1.*

*The circuit-breaker shall trip within the conventional time (see 8.6.2.1).*

**9.10.4 Test of effect of ambient temperature on the tripping characteristic**

*Compliance is checked by the following tests.*

a) *The circuit-breaker is placed in an ambient temperature of  $(35 \pm 2)$  K below the ambient air reference temperature until it has attained steady-state temperature.*

*A current equal to  $1,13 I_n$  (conventional non-tripping current) is passed through all poles for the conventional time. The current is then steadily increased within 5 s to  $1,9 I_n$ .*

*The circuit-breaker shall trip within the conventional time.*

b) *The circuit-breaker is placed in an ambient temperature of  $(10 \pm 2)$  K above the ambient air reference temperature until it has attained steady-state temperature.*

*A current equal to  $I_n$  is passed through all poles.*

*The circuit-breaker shall not trip within the conventional time.*

**9.11 Test of mechanical and electrical endurance**

**9.11.1 General test conditions**

*The circuit-breaker is fixed to a metal support unless it is designed for installation in an individual enclosure, in which case it shall be mounted accordingly, as specified in 9.2.*

## **IS/IEC 60898-1 : 2002**

*The test is made at rated voltage, at a current adjusted to the rated current by means of resistors and reactors in series, connected to the load terminals.*

*If air-core reactors are used, a resistor taking approximately 0,6 % of the current through the reactors is connected in parallel with each reactor.*

*The current shall have substantially sine-wave form and the power factor shall be between 0,85 and 0,9.*

*For single-pole circuit-breakers and for two-pole circuit-breakers with two protected poles, the metal support is connected to one side of the supply for the first half of the total number of operations and to the other side for the second half.*

*For two-pole circuit-breakers with one protected pole, the metal support is connected to the neutral of the supply.*

*For single-pole circuit-breakers with rated voltage 230/400 V the test shall be carried out at the lower voltage value.*

*The circuit-breaker is connected to the circuit with conductors of the appropriate size indicated in table 9.*

### **9.11.2 Test procedure**

*The circuit-breaker is submitted to 4 000 operating cycles with rated current.*

*Each operating cycle consists of a making operation followed by a breaking operation.*

*For circuit-breakers of rated current up to and including 32 A the operating frequency shall be 240 operating cycles per hour. During each operating cycle, the circuit-breaker shall remain open for at least 13 s.*

*For circuit-breakers of rated current above 32 A the operating frequency shall be 120 operating cycles per hour. During each operating cycle the circuit-breaker shall remain open for at least 28 s.*

*The circuit-breaker shall be operated as in normal conditions of use.*

*Care shall be taken that*

- the test apparatus does not damage the circuit-breaker under test;*
- the free movement of the operating means of the circuit-breaker under test is not impeded;*
- the speed of the operating means of the test apparatus is not unduly affected by the operating means of the circuit-breaker under test.*

*In case of circuit-breakers with dependent manual operation, the circuit-breaker shall be operated with an operating speed, during actuation, of 0,1 m/s  $\pm$  25 %, this speed being measured at the extremity when and where the operating means of the test apparatus touches the actuating means of the circuit-breaker under test. For rotary knobs the angular velocity shall correspond substantially to the above conditions, referred to the speed of the operating means (at its extremities) of the circuit-breaker under test.*

### 9.11.3 Condition of the circuit-breaker after test

Following the test of 9.11.2 the sample shall not show

- undue wear;
- discrepancy between the position of the moving contacts and of the corresponding position of the indicating device;
- damage to the enclosure permitting access to live parts by the test finger (see 9.6);
- loosening of electrical or mechanical connections;
- seepage of sealing compound.

Moreover, the circuit-breaker shall comply with the test of 9.10.1.2 and shall withstand the dielectric strength test according to 9.7.3, but at a voltage 500 V less than the value prescribed in 9.7.5 and without previous humidity treatment.

## 9.12 Short-circuit tests

### 9.12.1 General

Standard tests for the verification of the short-circuit performance consist of sequences of making and breaking operations, appropriate to the performance to be checked, which are summarized in table 16.

All circuit-breakers are tested at 500 A or 10  $I_n$ , whichever is the higher, according to 9.12.11.2 and at 1 500 A according to 9.12.11.3.

Circuit-breakers having a rated short-circuit capacity above 1 500 A are additionally tested

- at service short-circuit (breaking) capacity (see 3.5.5.2) according to 9.12.11.4.2 and 9.12.12.1; the service short-circuit capacity is obtained by multiplying the rated short-circuit capacity by a factor  $k$ , the values of which are given in table 18;
- at rated short-circuit capacity (see 5.2.4) according to 9.12.11.4.3 and to 9.12.12.2 if the factor  $k$  is less than 1, in which case new samples shall be used.

**Table 16 – Applicability of short-circuit tests**

Kind of test	Circuit-breaker to be tested	Verification after short-circuit tests according to subclause
Test at reduced short-circuit currents (9.12.11.2.1)	All circuit-breakers	9.12.12.1
Test to verify suitability for IT systems (9.12.11.2.2)	All circuit-breakers, except those rated 120 V or 120/240 V	
Tests at 1 500 A (9.12.11.3)	All circuit-breakers	
Tests at service short-circuit capacity (9.12.11.4.2)	Circuit-breakers with $I_{cn} > 1\,500\text{ A}$	9.12.12.1
Tests at rated short-circuit capacity (9.12.11.4.3)		9.12.12.2



### **9.12.2 Values of test quantities**

*All the tests concerning the verification of the rated short-circuit capacity shall be performed with the values stated by the manufacturer in accordance with the relevant tables of this standard.*

*The value of the applied voltage is that which is necessary to produce the specified power frequency recovery voltage.*

*The value of the power frequency recovery voltage (see 3.5.8.2) shall be equal to 105 % of the rated voltage of the circuit-breaker under test.*

- *For single-pole circuit-breakers having dual rated voltage value (e.g. 230/400 V) the power frequency recovery voltage shall be 105 % of the upper value (e.g. 400 V) for the tests according to item d) of 9.12.11.4.2, item b) of 9.12.11.4.3 and 9.12.11.2.2; it shall be 105 % of the lower value (e.g. 230 V) for the other tests of 9.12.*
- *For two-pole circuit-breakers having dual rated voltage values (e.g. 120/240 V) the recovery voltage shall be 105 % of the lower value (e.g. 120 V) for the tests according to 9.12.11.2 and 105 % of the upper value (e.g. 240 V) for the other tests of 9.12.*

**NOTE** The value of 105 % ( $\pm 5$  %) of the rated voltage is deemed to cover the effects of the variations of the system voltage under normal service conditions. The upper limit may be increased with the approval of the manufacturer.

### **9.12.3 Tolerances on test quantities**

*The tests are considered as valid if the r.m.s. values recorded in the test report differ from the values specified within the following tolerances:*

- *current  $\begin{matrix} +5 \\ 0 \end{matrix}$  %*
- *voltage (including recovery voltage):  $\pm 5$  %*
- *frequency  $\pm 5$  %.*

### **9.12.4 Test circuit for short-circuit performance**

*Figures 3 to 6 respectively give the diagrams of the circuits to be used for the tests concerning:*

- *a single-pole circuit-breaker (figure 3);*
- *a two-pole circuit-breaker with one protected pole (figure 4a);*
- *a two-pole circuit-breaker with two protected poles (figure 4b);*
- *a three-pole circuit-breaker (figure 5);*
- *a four-pole circuit-breaker (figure 6).*

*The resistances and reactances of the impedances  $Z$  and  $Z_1$  shall be adjustable to satisfy the specified test conditions. The reactors shall preferably be air-cored. They shall always be connected in series with the resistors and their value shall be obtained by series coupling of individual reactors; parallel connecting of reactors is permitted when these reactors have practically the same time-constant.*

*Since the transient recovery voltage (see 3.5.8.1) characteristics of test circuits including air-cored reactors are not representative of usual service conditions, the air-cored reactor in any phase shall be shunted by a resistor taking approximately 0,6 % of the current through the reactor.*

*If iron-core reactors are used, the iron-core power losses of these reactors shall not exceed the losses that would be absorbed by the resistors connected in parallel with the air-cored reactors.*

*There shall be one and only one point of the test circuit which is earthed; this may be the short-circuit link of the test circuit or the neutral point of the supply or any other convenient point. In any case the earthing method shall be stated in the test report.*

*In each test circuit for testing the rated short-circuit capacity, the impedances  $Z$  are inserted between the supply source  $S$  and the circuit-breaker under test.*

*When tests are made with current less than the rated short-circuit breaking capacity, the additional impedances  $Z_1$ , shall be inserted on the load side of the circuit-breaker.*

*For the tests at both the rated and the service short-circuit capacities, the circuit-breaker shall be connected with cables having a length of 0,75 m per pole and the maximum cross-section corresponding to the rated current according to table 5.*

**NOTE** It is recommended that 0,5 m be connected on the supply side and 0,25 m on the load side of the circuit-breaker under test.

*A resistor  $R_2$  of about  $0,5 \Omega$  is connected in series with a copper wire  $F$  as follows:*

- for the circuits in figures 3 and 4a, between the metal support and the selector switch  $P$ : this switch is in one of its two positions for approximately half the number of operations of the circuit-breaker, and in the other position for the remaining operations;*
- for the circuits in figures 4b, 5 and 6, between the metal support and the neutral of the supply.*

*The copper wire  $F$  shall be at least 50 mm in length and*

- 0,1 mm in diameter for circuit-breakers to be tested in free air, mounted on a metal support,*
- 0,3 mm in diameter for circuit-breakers to be tested in the smallest individual enclosure specified by the manufacturer.*

*Resistors  $R_1$  drawing a current of 10 A per phase are connected on the supply side of the circuit-breaker, between the impedances for adjusting the prospective current to the rated short-circuit capacity of the circuit-breaker.*

#### **9.12.5 Power factor of the test circuit**

*The power factor of each phase of the test circuit shall be determined according to a recognized method which shall be stated in the test report.*

*Two examples are given in annex A.*

*The power factor of a polyphase circuit is considered as the mean value of the power factors of each phase.*

The power-factor ranges are given in table 17.

Table 17 – Power factor ranges of the test circuit

Test current $I_{CC}$ A	Corresponding power factor range
$I_{CC} \leq 1\,500$	0,93 to 0,98
$1\,500 < I_{CC} \leq 3\,000$	0,85 to 0,90
$3\,000 < I_{CC} \leq 4\,500$	0,75 to 0,80
$4\,500 < I_{CC} \leq 6\,000$	0,65 to 0,70
$6\,000 < I_{CC} \leq 10\,000$	0,45 to 0,50
$10\,000 < I_{CC} \leq 25\,000$	0,20 to 0,25

### 9.12.6 Measurement and verification of $I^2t$ and of the peak current ( $I_p$ )

The  $I^2t$  and  $I_p$  values shall be measured during the tests of 9.12.11.2, 9.12.11.3 and 9.12.11.4.

In the case of tests of circuit-breakers in three-phase circuits, the  $I^2t$  values shall be measured on each pole.

The maximum  $I^2t$  values measured shall be recorded in the test report and they shall not exceed the corresponding values of the  $I^2t$  characteristic declared by the manufacturer.

### 9.12.7 Calibration of the test circuit

9.12.7.1 To calibrate the test circuit, links G having negligible impedance compared with that of the test circuit are connected in the positions shown in figures 3 to 6.

9.12.7.2 To obtain a prospective current equal to the rated short-circuit capacity of the circuit-breaker at the corresponding power factor as stated in table 17 impedances Z are inserted on the supply side of the links G.

9.12.7.3 To obtain a test current lower than the rated short-circuit capacity of the circuit-breaker, additional impedances  $Z_1$  are inserted on the load side of the links G, as shown in figures 3 to 6.

### 9.12.8 Interpretation of records

#### 9.12.8.1 Determination of the applied and power frequency recovery voltages

The applied and power frequency recovery voltages are determined from the record corresponding to the opening operation O, (see 9.12.11.1) made with the apparatus under test and estimated as indicated in figure 7. The voltage on the supply side shall be measured during the first cycle after arc extinction in all poles and after high frequency phenomena have subsided.

#### 9.12.8.2 Determination of the prospective short-circuit current

The a.c. component of the prospective current is taken as being equal to the r.m.s. value of the a.c. component of the calibration current (values corresponding to A2 of figure 7).

Where applicable, the prospective short-circuit current shall be the average of the prospective currents in all the phases.

### 9.12.9 Condition of the circuit-breaker for test

Circuit-breakers shall be tested in free air according to 9.12.9.1, unless they are designed for use only in enclosures specified by the manufacturer or they are intended for use in individual enclosures only, in which cases they shall be tested according to 9.12.9.2 or, with the agreement of the manufacturer, according to 9.12.9.1.

NOTE An individual enclosure is an enclosure designed to accept one device only.

The circuit-breaker shall be operated manually or by means of a test apparatus, simulating as closely as possible the normal closing operation.

Care shall be taken that

- the test apparatus does not damage the circuit-breaker under test;
- the free movement of the operating means of the circuit-breaker under test is not impeded;
- the speed of the operating means of the test apparatus is not unduly affected by the operating means of the circuit-breaker under test.

At the request of the manufacturer, in case of circuit-breakers with dependent manual operation, the circuit-breaker shall be operated with an operating speed, during actuation, of  $0,1 \text{ m/s} \pm 25 \%$ , this speed being measured where and when the operating means of the test apparatus touches the operating means of the circuit-breaker under test. For rotary knobs the angular velocity shall correspond substantially to the above conditions, referred to the speed of the operating means (at its extremities) of the circuit-breaker under test.

#### 9.12.9.1 Test in free air

The circuit-breaker under test is mounted as shown in figure H.1.

The polyethylene foil and the barrier of insulating material specified in annex H are placed as shown in figure H.1 for O operations only.

The grid(s) specified in annex H shall be so positioned that the bulk of the emitted ionized gases passes through the grid(s). The grid(s) shall be placed in the most unfavourable position(s).

NOTE If the position of the vents is not obvious, or if there are no vents, appropriate information should be provided by the manufacturer.

The grid circuit(s) (see figure H.3) shall be connected to the points B and C according to the test circuit diagrams of figures 3 to 6; for the test of single-pole circuit-breakers having a rated voltage of 230/400 V the grid circuit(s) shall, however, be connected between phases, to the points B and C' according to the test circuit diagram of figure 3.

The resistor  $R'$  shall have a resistance of  $1,5 \Omega$ . The copper wire  $F'$  (see figure H.3) shall have a length of 50 mm and a diameter of 0,12 mm for circuit-breakers having a rated voltage of 230 V and 0,16 mm for circuit-breaker having a rated voltage of 400 V or 230/400 V.

For circuit-breakers having a rated voltage of 120 V or 120/240 V the resistor  $R'$  shall have a resistance of  $0,75 \Omega$  and the copper wire shall have a diameter of 0,12 mm.

For test currents up to and including 1 500 A, the distance "a" shall be 35 mm.

## IS/IEC 60898-1 : 2002

For higher short-circuit currents up to  $I_{cn}$ , the distance "a" may be increased, in which case it shall be chosen from the series (40 – 45 – 50 – 55 – ...) mm and stated by the manufacturer.

For test currents greater than 1 500 A any additional barriers or insulating means which allow a shorter distance "a" shall also be stated by the manufacturer.

### 9.12.9.2 Test in enclosures

The test shall be performed with the circuit-breaker placed in an enclosure having the most unfavourable configuration under the most unfavourable conditions. The grid and the barrier of insulating material shown in figure H.1 are omitted.

NOTE This means that if other circuit-breakers (or other devices) are normally mounted in the direction(s) in which the grid(s) would be placed, these circuit-breakers (or other devices) should be installed there. They should be supplied as in normal use, but via F' and R' as defined in 9.12.9.1, and connected as shown in the appropriate figure (3, 4a, 4b, 5 or 6).

In accordance with the manufacturer's instructions, barriers or other means, or adequate clearances may be necessary to prevent ionized gases from affecting the installation.

The polyethylene foil as described in annex H is placed as shown in figure H.1 at a distance of 10 mm from the operating means, for O operations only.

### 9.12.10 Behaviour of the circuit-breaker during short-circuit tests

During the operating sequence of 9.12.11.2 or 9.12.11.3 or 9.12.11.4 the circuit-breaker shall not endanger the operator and shall permit reclosing after the time  $t$  as specified in 9.12.11.1, without removing it from the test arrangement.

The polyethylene foil shall show no holes visible with normal or corrected vision without additional magnification.

Furthermore, there shall be no permanent arcing, no flashover between poles or between poles and frame, no melting of the fuse  $F$  and, where applicable, of the fuse  $F'$ .

### 9.12.11 Test procedure

#### 9.12.11.1 General

The test procedure consists of a sequence of operations.

The following symbols are used for defining the sequence of operations:

O represents an opening operation;

CO represents a closing operation followed by an automatic opening;

$t$  represents the time interval between two successive short-circuit operations which shall be 3 min or such longer time as may be required by the thermal overcurrent release in order to permit the reclosing of the circuit-breaker. This longer time shall be indicated by the manufacturer.

The actual value of  $t$  shall be stated in the test report. If the sample does not allow reclosing after the time indicated by the manufacturer it is considered as having failed the test.

After arc extinction, the recovery voltage shall be maintained for a duration not less than 0,1 s.

**9.12.11.2 Tests at reduced short-circuit currents****9.12.11.2.1 Test on all circuit-breakers**

The additional impedances  $Z_1$  (see 9.12.7.3) are adjusted so as to obtain a current of 500 A or 10 times  $I_n$ , whichever is the higher, at a power factor between 0,93 and 0,98.

Each of the protected poles of the circuit-breaker is subjected separately to a test in a circuit the connections of which are shown in figure 3.

The circuit-breaker is caused to open automatically nine times, the circuit being closed six times by the auxiliary switch A and three times by the circuit-breaker itself.

The sequence of operations shall be

O - t - O - t - O - t - O - t - O - t - O - t - O - t - CO - t - CO - t - CO

For the test the auxiliary switch A is synchronized with respect to the voltage wave so that the six points of initiation for the opening operations are equally distributed over the half-wave with a tolerance of  $\pm 5^\circ$ .

**9.12.11.2.2 Short-circuit test on circuit-breakers rated 230 V, or 240 V or 230/400 V for verifying their suitability for use in IT systems**

The additional impedances  $Z_1$  (see 9.12.7.3) are adjusted so as to obtain a current of 500 A or 1,2 times the upper limit of the standard range of instantaneous tripping given in table 2, whichever is the higher, but not exceeding 2 500 A, at a power factor between 0,93 and 0,98, at a voltage 105 % of the rated voltage upper value.

For circuit-breakers having an instantaneous tripping value exceeding 20  $I_n$ , the impedances are adjusted as to obtain a current 1,2 times the upper limit of instantaneous tripping declared by the manufacturer, the 2 500 A limitation being disregarded.

Single-pole circuit-breakers and each protected pole of multipole circuit-breakers are subjected individually to a test in a circuit the connections of which are shown in figure 3, where the connection N shall be replaced by a connection to a phase.

The sequence of operations shall be

O - t - CO

For the O operation on the first protected pole the auxiliary switch A is synchronised with respect to the voltage wave so that the circuit is closed on the point 0° on the wave for this operation.

For the following O operations on the other protected poles to be tested (see C.2) this point is shifted each time by 30° with respect to the point on wave of the previous test, with a tolerance of  $\pm 5^\circ$ .

**9.12.11.3 Test at 1 500 A**

For circuit-breakers having a rated short-circuit capacity of 1 500 A, the test circuit is calibrated according to 9.12.7.1 and 9.12.7.2, to obtain a current of 1 500 A at a power factor corresponding to this current according to table 17.

For circuit-breakers having a rated short-circuit capacity exceeding 1 500 A, the test circuit is calibrated according to 9.12.7.1 and 9.12.7.3, at a power factor corresponding to 1 500 A, according to table 17.

Single-pole circuit-breakers are tested in a circuit, the diagram of which is shown in figure 3.

Two-pole circuit-breakers with one protected pole are tested in a circuit, the diagram of which is shown in figure 4a.

Two-pole circuit-breakers with two protected poles are tested in a circuit, the diagram of which is shown in figure 4b.

Three-pole circuit-breakers and four-pole circuit-breakers with three protected poles are tested in a circuit, the diagrams of which are shown in figures 5 and 6 respectively.

For three-pole circuit-breakers, no connection is made between the neutral of the supply and the common point, if any, on the load side of the circuit-breaker.

For four-pole circuit-breakers with three protected poles, the neutral of the supply is connected through the unprotected pole or the switched neutral pole to the common point on the load side of the circuit-breaker.

If the neutral of a four-pole circuit-breaker is not marked by the manufacturer, the tests are repeated with three new samples, using successively each pole as neutral in turn.

For the test of single-pole and two-pole circuit-breakers, the auxiliary switch A is synchronized with respect to the voltage wave so that the six points of initiation are equally distributed over the half-wave with a tolerance of  $\pm 5^\circ$ .

The sequence of operations shall be as specified in 9.12.11.2, except for single-pole circuit-breakers of rated voltage 230/400 V. In that case only two CO operations are performed following the six O operations; in addition these circuit-breakers are then tested by performing simultaneously one O operation, one circuit-breaker being inserted in each phase of the test circuit specified for three-pole circuit-breakers (figure 5), without synchronization of the auxiliary switch establishing the short-circuit.

For three-pole and four-pole circuit-breakers, random point-on-wave testing is acceptable.

**9.12.11.4 Test above 1 500 A**

**9.12.11.4.1 Ratio *k* between service short-circuit capacity and rated short-circuit capacity**

The ratio *k* between the service short-circuit capacity and the rated short-circuit capacity shall be in accordance with table 18.

**Table 18 – Ratio *k* between service short-circuit capacity (*I<sub>cs</sub>*) and rated short-circuit capacity (*I<sub>cn</sub>*)**

<i>I<sub>cn</sub></i>	<i>k</i>
<i>I<sub>cn</sub></i> ≤ 6 000 A	1
6 000 A < <i>I<sub>cn</sub></i> ≤ 10 000 A	0,75 <sup>a</sup>
<i>I<sub>cn</sub></i> > 10 000 A	0,5 <sup>b</sup>
a Minimum value of <i>I<sub>cs</sub></i> : 6 000 A	
b Minimum value of <i>I<sub>cs</sub></i> : 7 500 A	

**9.12.11.4.2 Test at service short-circuit capacity ( $I_{cs}$ )**

a) The test circuit is calibrated according to 9.12.7.1 and 9.12.7.3, with a power factor in accordance with table 17.

Three samples are tested in the relevant circuit specified in 9.12.11.3.

When the supply and load terminals of the circuit-breakers under test are not marked, two of the samples are connected in one direction and the third sample in the reverse direction.

b) For single-pole and two-pole circuit-breakers the sequence of operation is:

$$O - t - O - t - CO$$

For the O operations, the auxiliary switch A is synchronized with respect to the voltage wave so that the circuit is closed on the point 0° on the wave for the O operation on the first sample.

This point is then shifted by 45° for the second O operation on the first sample; for the second sample, the two O operations shall be synchronized at 15° and 60° and for the third sample at 30° and 75°.

The synchronization tolerance shall be ±5°.

For two-pole circuit-breakers, the same pole shall be used as reference for the purpose of synchronization.

This test procedure is shown in table 19.

**Table 19 – Test procedure for  $I_{cs}$  in the case of single- and two-pole circuit-breakers**

Operation	Sample		
	1	2	3
1	O (0°)	O (15°)	O (30°)
2	O (45°)	O (60°)	O (75°)
3	CO	CO	CO

c) For three-pole and four-pole circuit-breakers the sequence of operations is:

$$O - t - CO - t - CO$$

For the O operations, the auxiliary switch A is synchronized with respect to the voltage wave so that the circuit is closed on any point (x°) on the wave for the O operation on the first sample.

This point is then shifted by 60° for the O operation on the second sample and by a further 60° for the O operation on the third sample.

The synchronization tolerance shall be ±5°. The same pole shall be used as reference for the purpose of synchronization for the different samples.

This test procedure is shown in table 20.

**Table 20 – Test procedure for  $I_{cs}$  in the case of three- and four-pole circuit-breakers**

Operation	Sample		
	1	2	3
1	O (x°)	O (x°+60°)	O (x°+120°)
2	CO	CO	CO
3	CO	CO	CO



- d) For single-pole circuit-breakers of rated voltage 230/400 V an additional set of three samples is tested in a circuit according to figure 5,

These samples are inserted one in each phase of the test circuit, without synchronization of the auxiliary switch A establishing the short-circuit.

No connection shall be made between the neutral of the supply and the common point on the load side of the circuit-breakers.

The test procedure is shown in table 21.

NOTE During this test the  $I^2t$  values need not be measured.

**Table 21 – Test procedure for  $I_{cs}$  in the case of three-phase tests for single-pole circuit-breakers of rated voltage 230/400 V**

Operation	Sample		
	1	2	3
1	O	O	O
2	-	CO	O
3	CO	-	CO
4	CO	CO	-

**9.12.11.4.3 Test at rated short-circuit capacity ( $I_{cn}$ )**

- a) The test circuit is calibrated according to 9.12.7.1 and 9.12.7.2.

Three samples are tested in the relevant circuit specified in 9.12.11.3.

When the supply and load terminals of the circuit-breakers under test are not marked, two of the samples are connected in one direction and the third sample in the reverse direction.

The sequence of operations is

O – t – CO

For the O operations, the auxiliary switch A is synchronized with respect to the voltage wave so that the circuit is closed on the point 15° on the wave for the O operation on the first sample.

This point is then shifted by 30° for the O operation of the second sample and by further 30° for the O operation of the third sample.

The synchronization tolerance shall be ±5°.

For multipole circuit-breakers the same pole shall be used as reference for the purpose of synchronization.

The test procedure is shown in table 22.

**Table 22 – The test procedure for  $I_{cn}$**

Operation	Sample		
	1	2	3
1	O (15°)	O (45°)	O (75°)
2	CO	CO	CO

b) For single-pole circuit-breakers of rated voltage 230/400 V, an additional set of four samples is tested in a circuit according to figure 5

Three of these samples are inserted one in each phase of the test circuit, without synchronization of the auxiliary switch A establishing the short-circuit.

No connection shall be made between the neutral of the supply and the common point on the load side of the circuit-breakers.

The test procedure is shown in table 23.

After the second O operation of the sample shown as No. 1 in table 23 this sample shall be replaced by the fourth sample.

NOTE During this test the  $I^2t$  values need not be measured.

**Table 23 – Test procedure for  $I_{cn}$  in the case of three-phase tests for single-pole circuit-breakers of rated voltage 230/400 V**

Operation	Sample			
	1	2	3	4
1	O	O	O	–
2	O	CO	–	–
3	–	–	CO	O

**9.12.12 Verification of the circuit-breaker after short-circuit tests**

**9.12.12.1 Verifications after the tests at reduced short-circuit currents, at 1 500 A and at service short-circuit capacity**

After the tests according to 9.12.11.2, 9.12.11.3 or 9.12.11.4.2, the circuit-breakers shall show no damage impairing their further use and shall, without maintenance, withstand the following tests.

- a) Leakage current across open contacts, according to 9.7.6.3.
- b) Dielectric strength tests according to 9.7.3, carried out between 2 h and 24 h after the short-circuit tests at a voltage of 500 V less than the value prescribed in 9.7.5 and without previous humidity treatment.

During these tests, after the test carried out under the conditions specified in item a) of 9.7.2, it shall be verified that the indicating means show the open position and during the test carried out under the conditions specified in item b) of 9.7.2 the indicating means shall show the closed position.

- c) Moreover, after the test of 9.12.11.3 or 9.12.11.4.2, the circuit-breakers shall not trip when a current equal to 0,85 times the conventional non-tripping current is passed through all poles for the conventional time, starting from cold.

At the end of this verification the current is steadily increased, within 5 s, to 1,1 times the conventional tripping current.

The circuit-breakers shall trip within the conventional time.

**9.12.12.2 Verifications after the short-circuit test at rated short-circuit capacity**

*After the tests according to 9.12.11.4.3, the polyethylene foil shall show no holes visible with normal or corrected vision without additional magnification and the circuit-breakers shall show no damage impairing their further use and shall, without maintenance, withstand the following tests:*

- a) *Leakage current across open contacts, according to 9.7.6.3.*
- b) *Dielectric strength tests according to 9.7.3, carried out between 2 h and 24 h after the short-circuit tests at a voltage of 900 V and without previous humidity treatment.*

*During these tests, after the test carried out under the conditions specified in item a) of 9.7.2, it shall be verified that the indicating means show the open position, and during the test carried out under the conditions specified in item b) of 9.7.2 the indicating means shall show the closed position.*

- c) *Moreover the circuit-breakers shall trip within the time corresponding to the test c of table 7 when a current equal to  $2,8 I_n$  is passed through all poles, the lower time limit being 0,1 s instead of 1 s.*

*The sample shown as number 1 in table 23 is not subjected to the verification of this subclause, but it shall nevertheless comply with the requirements of 9.12.10.*

**9.13 Mechanical stresses**

**9.13.1 Mechanical shock**

**9.13.1.1 Test device**

*The circuit-breaker is subjected to mechanical shocks using an apparatus as shown in figure 8.*

*A wooden base A is fixed to a concrete block and a wooden platform B is hinged to base A. This platform carries a wooden board C, which can be fixed at various distances from the hinge and in two vertical positions.*

*The end of board B bears a metal stop-plate D which rests on a coiled spring having a constant  $c$  of 25 N/mm.*

*The circuit-breaker is secured to the vertical board in such a way that the distance of the horizontal axis of the sample is 180 mm from the platform, the vertical board being in turn so fixed that the distance of the mounting surface is 200 mm from the hinge, as shown in the figure 8.*

*On the surface C, opposite the mounting surface of the circuit-breaker, a supplementary mass is fixed so that the static force on the metal stop-plate is 25 N in order to ensure that the moment of inertia of the complete system is substantially constant.*

**9.13.1.2 Test procedure**

*With the circuit-breaker in the closed position, but not connected to any electrical source, the platform is lifted at its free end and then allowed to fall 50 times from a height of 40 mm, the interval between consecutive falls being such that the sample is allowed to come to rest.*

*The circuit-breaker is then secured to the opposite side of the vertical board C and the platform is allowed to fall 50 times as before.*

*After this test, the vertical board is turned through 90° about its vertical axis and, if necessary, repositioned so that the vertical axis of symmetry of the circuit-breaker is 200 mm from the hinge.*

*The platform is then allowed to fall 50 times as before, with the circuit-breaker on one side of the vertical board, and 50 times with the circuit-breaker on the opposite side.*

*Before each change of position, the circuit-breaker is manually opened and closed.*

*During the tests, the circuit-breaker shall not open.*

### **9.13.2 Resistance to mechanical stresses and impact**

*Compliance is checked on those exposed parts of the circuit-breaker mounted as for normal use (see note to 8.1.6), which may be subjected to mechanical impact in normal use, by the test of 9.13.2.1 for all types of circuit-breakers and, in addition, by the tests specified in:*

- 9.13.2.2 for screw-in type circuit-breakers;*
- 9.13.2.3 for circuit-breakers intended to be mounted on a rail and for all types of plug-in circuit-breakers designed for surface mounting;*
- 9.13.2.4 for plug-in type circuit-breakers, the holding in position of which depends solely on their connections.*

*Circuit-breakers only intended to be totally enclosed are not submitted to this test.*

**9.13.2.1** *The samples are subjected to blows by means of an impact-test apparatus as shown in figures 10 to 14.*

*The head of the striking element has a hemispherical face of radius 10 mm and is of polyamide having a Rockwell hardness of HR 100.*

*The striking element has a mass of  $(150 \pm 1)$  g and is rigidly fixed to the lower end of a steel tube with an external diameter of 9 mm and a wall thickness of 0,5 mm, which is pivoted at its upper end in such a way that it swings only in a vertical plane.*

*The axis of the pivot is  $(1\ 000 \pm 1)$  mm above the axis of the striking element.*

*For determining the Rockwell hardness of the polyamide of the head of the striking element, the following conditions apply:*

- diameter of the ball:  $(12,7 \pm 0,0025)$  mm,*
- initial load:  $(100 \pm 2)$  N;*
- overload:  $(500 \pm 2,5)$  N.*

NOTE 1 Additional information concerning the determination of the Rockwell hardness of plastics is given in ISO 2039-2.

*The design of the test apparatus is such that a force of between 1,9 N and 2,0 N has to be applied to the face of the striking element to maintain the tube in the horizontal position.*

*Surface-type circuit-breakers are mounted on a sheet of plywood, 8 mm thick and 175 mm square, secured at its top and bottom edges to a rigid bracket, which is part of the mounting support, as shown in figure 12.*

*The mounting support shall have a mass of  $(10 \pm 1)$  kg and shall be mounted on a rigid frame by means of pivots.*

*The frame is fixed to a solid wall.*

*Flush-type circuit-breakers are mounted in a device as shown in figure 13, which in turn is fixed to the mounting support shown in figure 12.*

*Panel board type circuit-breakers are mounted in a device as shown in figure 14, which in turn is fixed to the mounting support shown in figure 12.*

## **IS/IEC 60898-1 : 2002**

*Plug-in type circuit-breakers are mounted complete with the appropriate means for the plug-in connection, which means are fixed on the sheet of plywood for the surface-type, or in the device according to figure 13 for the flush-type or figure 14 for the panel-board-type, as applicable.*

*Screw-in type circuit-breakers are mounted in their appropriate base which is fixed to a mounting plate made of a plywood sheet, 8 mm thick and 175 mm square.*

*Circuit-breakers for screw fixing are fixed by means of screws.*

*Circuit-breakers for rail mounting are mounted on their appropriate rail.*

*Circuit-breakers intended both for screw fixing and for rail mounting shall be fixed with screws for the tests.*

*The design of the test apparatus is such that*

- the sample can be moved horizontally and turned about an axis perpendicular to the surface of the plywood;*
- the plywood can be turned about a vertical axis.*

*The circuit-breaker is mounted on the plywood or on the appropriate device as for normal use, with covers, if any, so that the point of impact lies in the vertical plane through the axis of the pivot of the pendulum.*

*Cable entries which are not provided with knock-outs are left open. If they are provided with knock-outs, two of them are opened.*

*Before applying the blows, fixing screws of bases, covers and the like are tightened with a torque equal to two-thirds of that specified in table 10.*

*The striking element is allowed to fall from a height of 10 cm onto surfaces which are exposed when the circuit-breaker is mounted as for normal use.*

*The height of fall is the vertical distance between the position of a checking point when the pendulum is released and the position of that point at the moment of impact.*

*The checking point is marked on the surface of the striking element where the line through the point of intersection of the axis of the steel tube of the pendulum and that of the striking element, and perpendicular to the plane through both axes, meets the surface.*

**NOTE 2** *Theoretically, the centre of gravity of the striking element should be the checking point. As the centre of gravity is difficult to determine, the checking point is chosen as specified above.*

*Each circuit-breaker is subjected to ten blows, two of them being applied to the operating means and the remainder being evenly distributed over the parts of the sample likely to be subjected to impacts.*

*The blows are not applied to knock-out areas or to any openings covered by transparent material.*

*In general, one blow is applied on each lateral side of the sample after it has been turned as far as possible, but not through more than 60°, about a vertical axis, and two blows are applied, each approximately midway between the blows on a lateral side and the blows on the operating means.*

*The remaining blows are then applied in the same way, after the sample has been turned through 90° about that of its axes which is perpendicular to the plywood.*

*If cable entries or knock-outs are provided, the sample is so mounted that the two lines of blows are as nearly as possible equidistant from these entries.*

*Two blows shall be applied on the operating means as follows: one when the operating means is in the closed position and the other when it is in the open position.*

*After the test the samples shall show no damage within the meaning of this standard. In particular covers which, when broken, make live parts accessible or impair the further use of the circuit-breaker, operating means, linings and barriers of insulating material and the like, shall not show such damage.*

*In case of doubt, it shall be verified that removal and replacement of external parts, such as enclosures and covers, is possible without these parts or their lining being damaged.*

**NOTE 3** Damage to the appearance, small dents which do not reduce the creepage distances or clearances below the values specified in 8.1.3 and small chips which do not adversely affect the protection against electric shock are neglected.

**9.13.2.2** *Screw-in type circuit-breakers are screwed home in an appropriate base, a torque of 2,5 Nm being applied for 1 min.*

*After the test the sample shall show no damage impairing its further use.*

**9.13.2.3** *Circuit-breakers designed to be mounted on a rail are mounted as for normal use, but without cables being connected and without any cover or coverplate, on a rail rigidly fixed on a vertical rigid wall.*

*Plug-in circuit-breakers designed for surface mounting are mounted complete with the appropriate means for the plug-in connection but without cables being connected and without any cover-plate.*

*A downward vertical force of 50 N is applied without jerks for 1 min on the forward surface of the circuit-breaker, immediately followed by an upward vertical force of 50 N for 1 min (see figure 15).*

*During this test, the circuit-breaker shall not become loose and after the test the circuit-breaker shall show no damage impairing its further use.*

**9.13.2.4** *Plug-in type circuit-breakers, the holding in position of which depends solely on their connections, are mounted, complete with the appropriate plug-in base but without cables being connected and without any cover-plate, on a vertical rigid wall.*

*A force of 20 N is applied to the circuit-breaker portion at a point equidistant between the plug-in connections, without jerks for 1 min (see figure 17).*

*During this test the circuit-breaker portion shall not become loose and shall not move from the base portion and after the test both portions shall show no damage impairing their further use.*

## **9.14 Test of resistance to heat**

**9.14.1** *The samples, without removable covers, if any, are kept for 1 h in a heating cabinet at a temperature of  $(100 \pm 2)$  °C; removable covers, if any, are kept for 1 h in the heating cabinet at a temperature of  $(70 \pm 2)$  °C.*

*During the test the samples shall not undergo any change impairing their further use and sealing compound, if any, shall not flow to such an extent that live parts are exposed.*

*After the test and after the samples have been allowed to cool down to approximately room temperature, there shall be no access to live parts which are normally not accessible when the samples are mounted as for normal use, even if the standard test finger is applied with a force not exceeding 5 N.*

*After the test, markings shall still be legible.*

*Discoloration, blisters or a slight displacement of the sealing compound are disregarded, provided that safety is not impaired within the meaning of this standard.*

**9.14.2** *External circuit-breaker parts made of insulating material necessary to retain in position current-carrying parts and parts of the protective circuit are subjected to a ball-pressure test by means of the apparatus shown in figure 16 except that, where applicable, the insulating parts necessary to retain in position the terminals for protective conductors in a box shall be tested as specified in 9.14.3.*

*The part to be tested is placed on a steel support with the appropriate surface in the horizontal position and a steel ball of 5 mm diameter is pressed against this surface with a force of 20 N.*

*The test is made in a heating cabinet at a temperature of  $(125 \pm 2)$  °C.*

*After 1 h, the ball is removed from the sample which is then cooled down within 10 s to approximately room temperature by immersion in cold water.*

*The diameter of the impression caused by the ball is measured and shall not exceed 2 mm.*

**9.14.3** *External circuit-breaker parts made of insulating material not necessary to retain in position current-carrying parts and parts of the protective circuit, even though they are in contact with them, are subjected to a ball-pressure test in accordance with 9.14.2, but the test is made at a temperature of  $(70 \pm 2)$  °C, or  $(40 \pm 2)$  °C plus the highest temperature rise, determined for the relevant part during the test of 9.8, whichever is the higher.*

**NOTE 1** For the purpose of the tests of 9.14.2 and 9.14.3, bases of surface-type circuit-breakers are considered as external parts.

**NOTE 2** The tests of 9.14.2 and 9.14.3 are not made on parts of ceramic material.

**NOTE 3** If two or more of the insulating parts referred to in 9.14.2 and 9.14.3 are made of the same material, the test according to 9.14.2 or 9.14.3, as applicable, is carried out on only one of these parts.

### **9.15 Resistance to abnormal heat and to fire (glow-wire test)**

*The glow-wire test is performed in accordance with Clauses 4 to 10 of IEC 60695-2-10 under the following conditions:*

- for external parts of circuit-breakers made of insulating material necessary to retain in position current-carrying parts and parts of the protective circuit, by the test made at a temperature of  $(960 \pm 15)$  °C;*
- for all other external parts made of insulating material, by the test made at a temperature of  $(650 \pm 10)$  °C.*

**NOTE 1** The glow-wire test is applied to ensure that an electrically heated test wire under defined test conditions does not cause ignition of insulating parts, or to ensure that a part of insulating material, which might be ignited by the heated test wire under defined conditions, has a limited time to burn without spreading fire by flame or burning parts or droplets falling down from the tested part.

**NOTE 2** For the purpose of this test, bases of surface-type circuit-breakers are considered as external parts.

**NOTE 3** The test is not made on parts of ceramic material.

**NOTE 4** If a number of insulating parts is made of the same material, the test is carried out only on one of these parts, according to the appropriate glow-wire test temperature.

*The test is made on one sample.*

*In case of doubt, the test is repeated on two further samples.*

The test is made by applying the glow-wire once.

The sample shall be positioned during the test in the most unfavourable position of its intended use (with the surface tested in a vertical position).

The tip of the glow-wire shall be applied to the specified surface of the test sample taking into account the conditions of intended use under which a heated or glowing element may come into contact with the sample.

The sample is regarded as having passed the glow-wire test if

- there is no visible flame and no sustained glowing,
- flames and glowing on the sample extinguish themselves within 30 s after the removal of the glow-wire.

There shall be no ignition of the tissue paper or scorching of the pinewood board.

### 9.16 Test of resistance to rusting

All grease is removed from the parts to be tested by immersion in a cold chemical degreaser such as methyl-chloroform or refined petrol, for 10 min. The parts are then immersed for 10 min in a 10 % solution of ammonium chloride in water at a temperature of  $(20 \pm 5) ^\circ\text{C}$ .

Without drying, but after shaking off any drops, the parts are placed for 10 min in a box containing air saturated with moisture at a temperature of  $(20 \pm 5) ^\circ\text{C}$ .

After the parts have been dried for 10 min in a heating cabinet at a temperature of  $(100 \pm 5) ^\circ\text{C}$ , their surfaces shall show no signs of rust.

NOTE 1 Traces of rust on sharp edges and any yellowish film removable by rubbing are ignored.

For small springs and the like and for inaccessible parts exposed to abrasion, a layer of grease may provide sufficient protection against rusting. Such parts are only subjected to the test if there is a doubt as to the effectiveness of the grease film, and in such a case the test is made without previous removal of the grease.

NOTE 2 When using the liquid specified for the test, adequate precautions should be taken to prevent inhalation of the vapour.

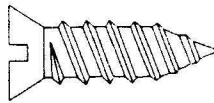
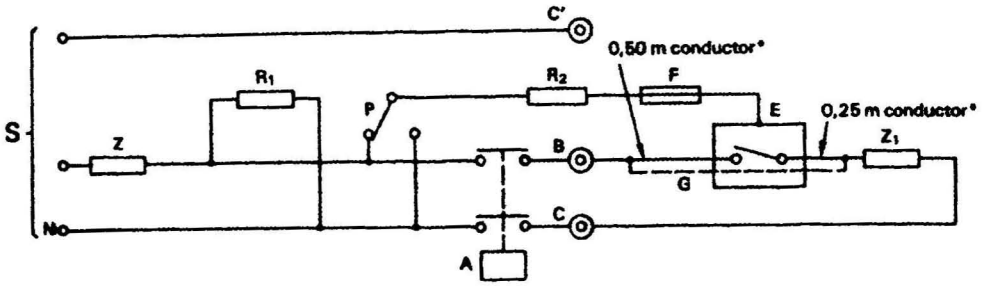

Figure 1 – Thread forming tapping screw (3.3.22)



Figure 2 – Thread cutting tapping screw (3.3.23)





NOTE For the key to figures 3 to 6 see figure 6.

Figure 3 – Single pole circuit-breaker

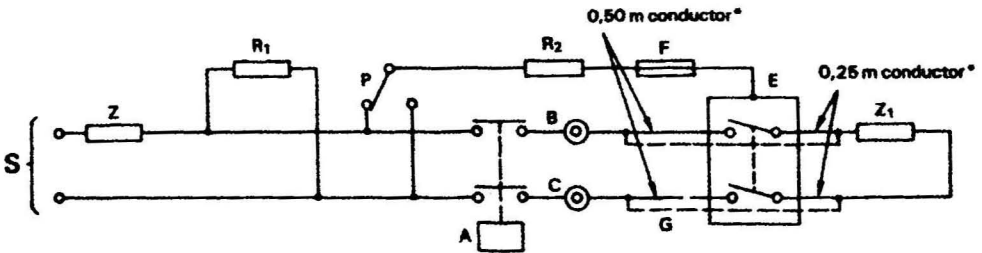

Figure 4a – Two-pole circuit-breaker with one protected pole

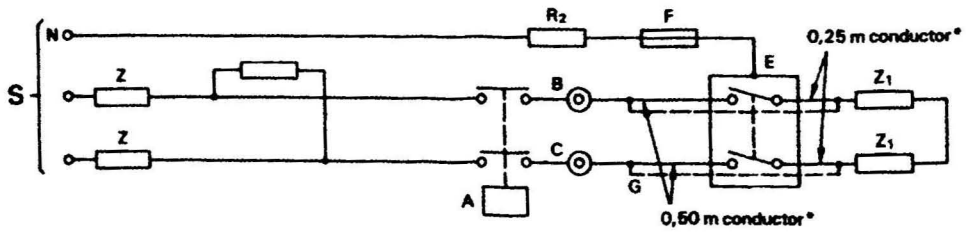

Figure 4b – Two-pole circuit-breaker with two protected poles

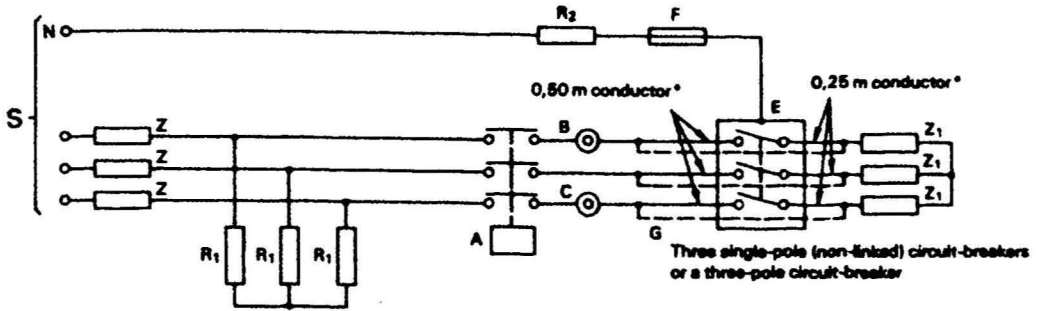

Figure 5 – Three-pole circuit-breaker (or three single-pole circuit-breakers)

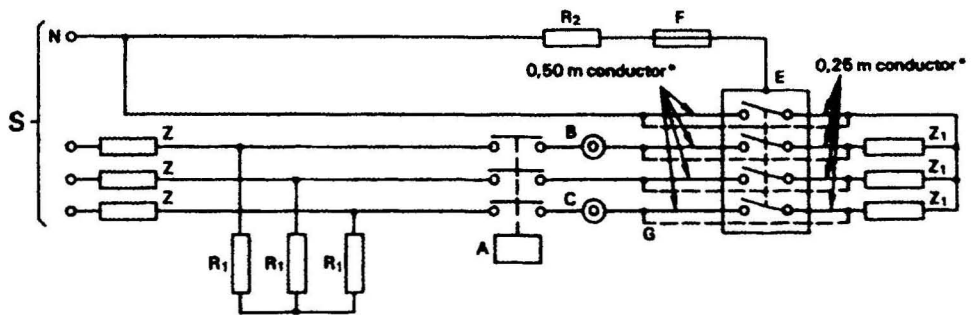

Figure 6 – Four-pole circuit-breaker

**Key**

S = supply source

N = neutral

Z = impedances for adjusting the current to the rated short-circuit capacity

Z<sub>1</sub> = Impedances for adjusting the test to values lower than the rated short-circuit capacity

R<sub>1</sub> = resistors

E = enclosure or support

A = auxiliary switch synchronized with to the voltage wave

NOTE In figures 3 and 4a, A may also be a single-pole switch.

G = negligible impedance connection for circuit calibration

R<sub>2</sub> = resistor 0,5 Ω

F = copper wire

P = selector switch

B, C and C': points of connection of the shown in annex H (see 9.12.9.1)

\* According to table 4 (see 9.12.4)

Figure 3 to 6 – Test circuits for short-circuit tests

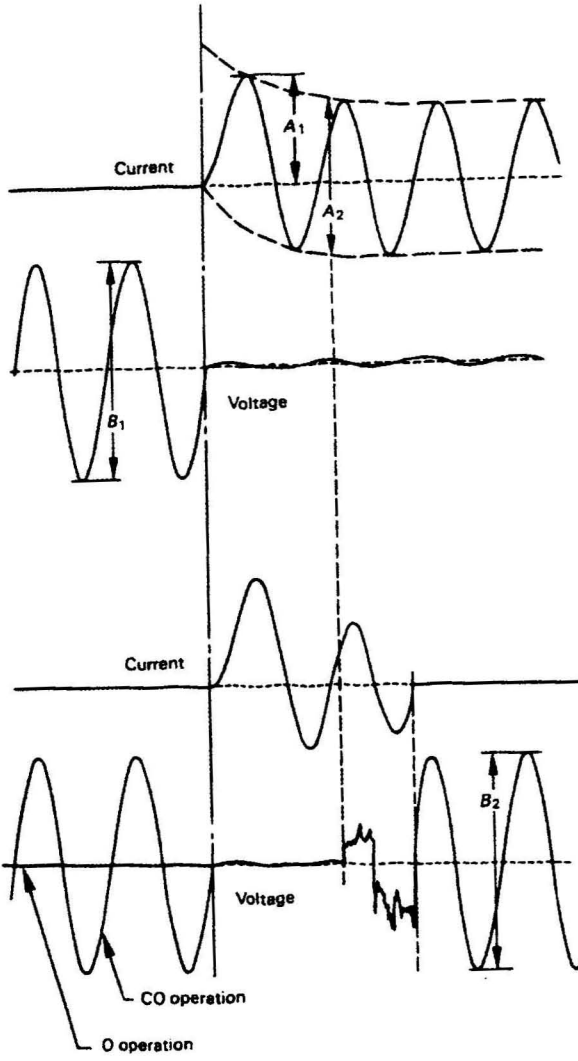

a) = Calibration of circuit

$A_1$  = Prospective peak making current

$\frac{A_2}{2\sqrt{2}}$  = Prospective symmetrical breaking current (r.m.s. value)

$\frac{B_1}{2\sqrt{2}}$  = Applied voltage (r.m.s. value) (see 3.5.7)

b) = O or CO operation

$\frac{A_2}{2\sqrt{2}}$  = Breaking capacity (r.m.s. value)

$A_1$  = Making capacity (peak value)

$\frac{B_2}{2\sqrt{2}}$  = Recovery voltage (r.m.s. value) (see 3.5.8)

NOTE The amplitude of the voltage trace, after initiation of the test current, varies according to the relative positions of the closing device, the adjustable impedances, and the voltage sensing devices, and according to the test diagram.

Figure 7 – Example of short-circuit making or breaking test record in the case of a single-pole device on single phase a.c.

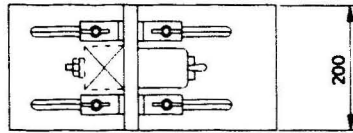
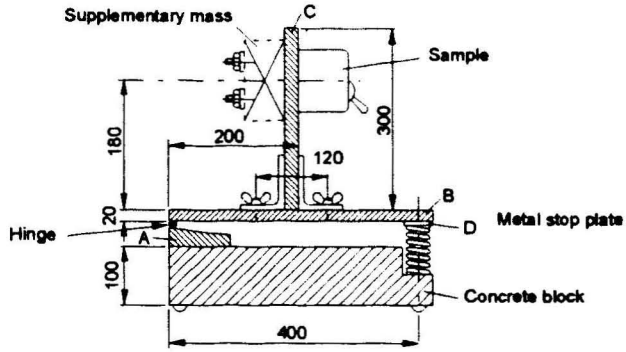

Consecutive test positions

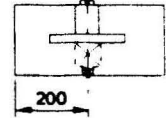
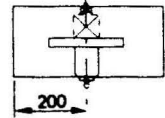
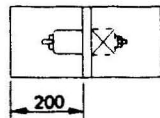
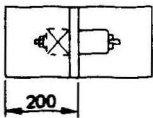

Dimensions in millimetres

Figure 8 – Mechanical shock test apparatus (9.13.1)

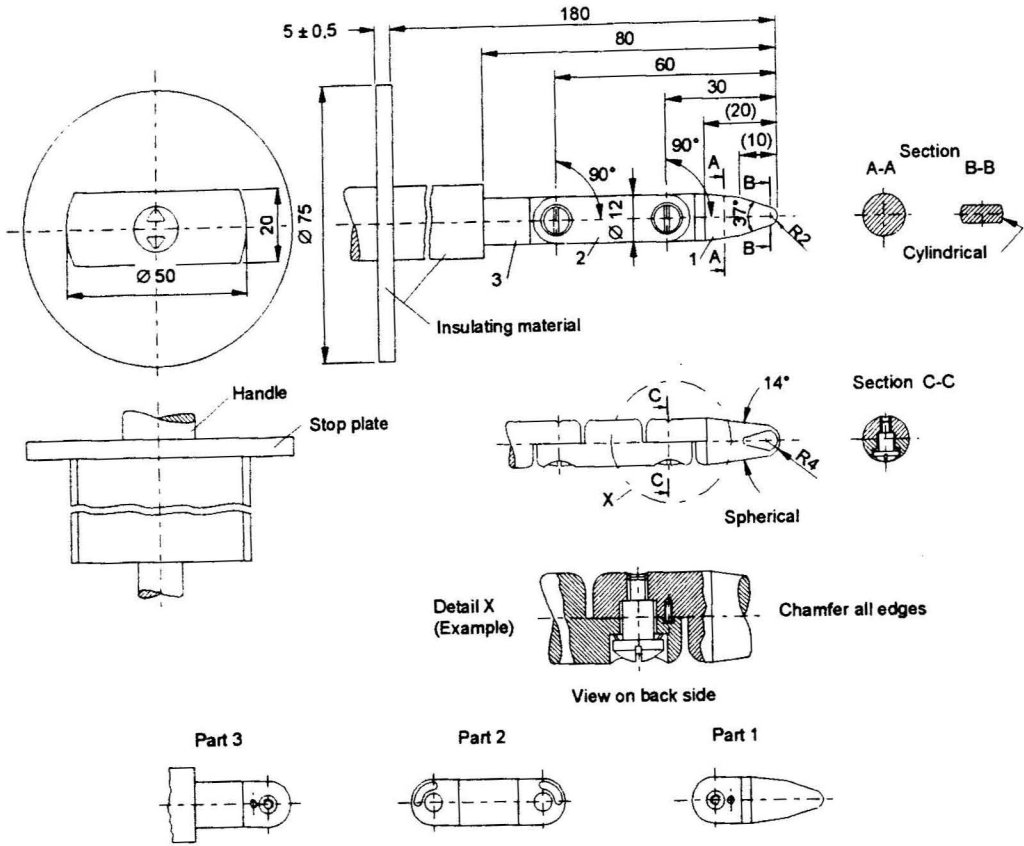

**Dimensions in millimetres**

Tolerances on dimensions without specific tolerance

on angles  $\begin{matrix} 0 \\ -10' \end{matrix}$

on linear dimensions:

up to 25 mm  $\begin{matrix} 0 \\ -0,05 \end{matrix}$

over 25 mm:  $\pm 0,2$

Material of finger: e.g. heat-treated steel

Both joints of this finger may be bent through an angle of  $90^\circ \begin{matrix} +10^\circ \\ 0 \end{matrix}$ , but in the one and same direction only.

Using the pin and groove solution is only one of the possible approaches in order to limit the bending angle to  $90^\circ$ . For this reason dimensions and tolerances of these details are not given in the drawing. The actual design must ensure a  $90^\circ$  bending angle with a 0 to  $+10^\circ$  tolerance.

**Figure 9 – Standard test finger (9.6)**

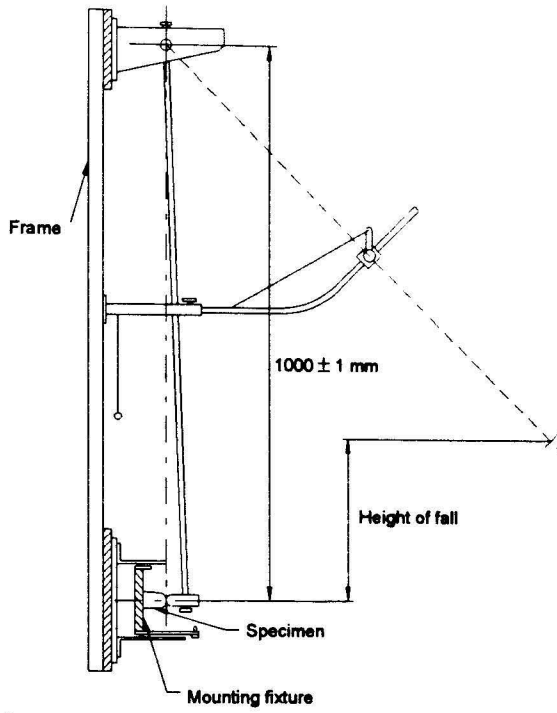

*Dimensions in millimetres*

**Figure 10 – Mechanical impact test apparatus (9.13.2)**

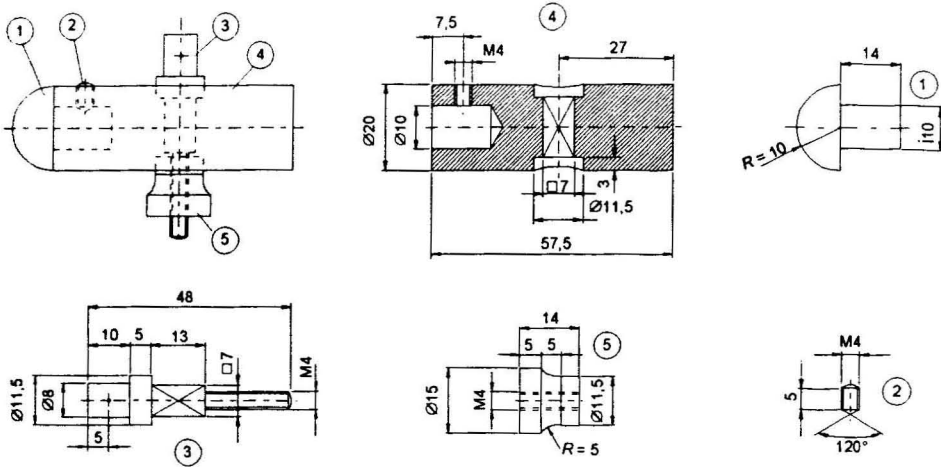

Dimensions in millimetres

Material of the parts:

①: polyamide

② ③ ④ ⑤: steel Fe 360

Figure 11 – Striking element for pendulum for mechanical impact test apparatus (9.13.2)

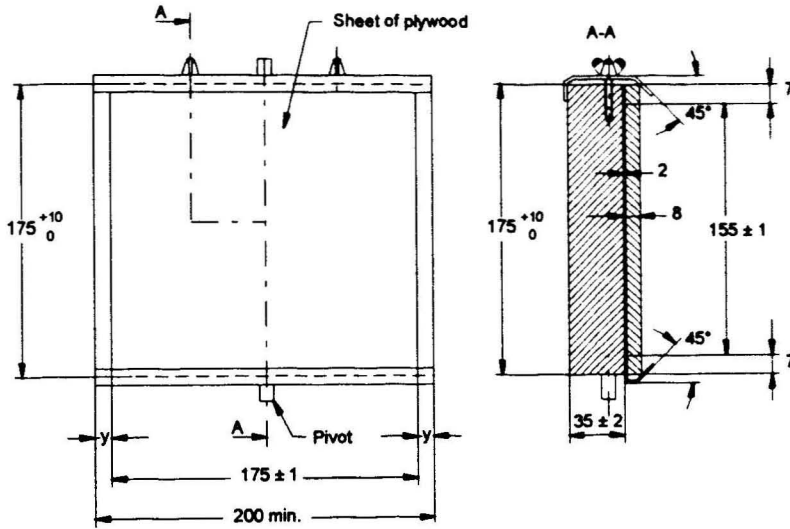

Dimensions in millimetres

**Key**

- 1 Main support of mass ( $10 \pm 1$ ) kg
- 2 Pivots for rotation about a vertical axis
- 3 Mounting plate (of wood for surface-type; for the other types, see figures 13 and 14)
- 4 Clamps to permit horizontal movement

**Figure 12 – Mounting support for mechanical impact test (9.13.2)**



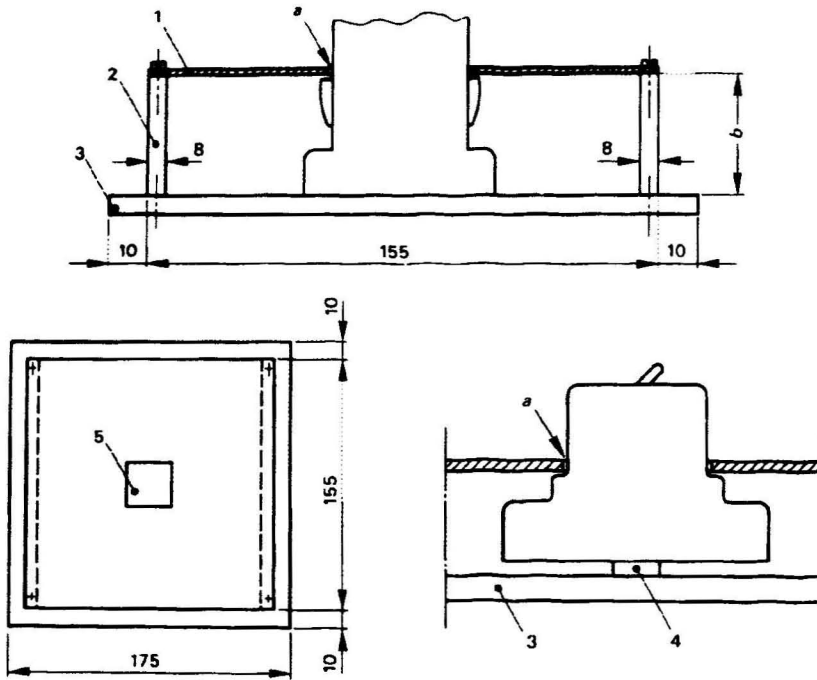

*Dimensions in millimetres*

**Key**

- 1 Interchangeable steel plate with a thickness of 1 mm
- 2 Aluminium plates with a thickness of 8 mm
- 3 Mounting plate
- 4 Rail for circuit-breakers designed for rail mounting
- 5 Cut-out for the circuit-breaker in the steel plate
  - a) the distance between the edges of the cut-out and the faces of the circuit-breaker shall be between 1 mm and 2 mm
  - b) the height of the aluminium plates shall be such that the steel plate rests on the supports of the circuit-breaker or, if the circuit-breaker has no such support, the distance from live parts, which are to be protected by an additional cover plate, to be on the underside of the steel, is 8 mm.

**Figure 13 – Example of mounting for a rear fixed circuit-breaker for mechanical impact test (9.13.2)**

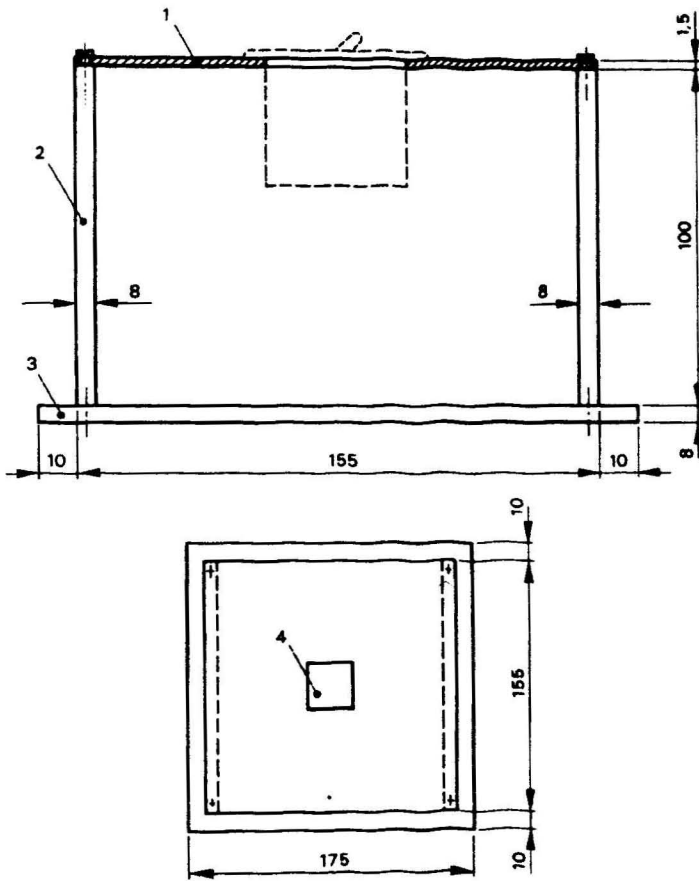

*Dimensions in millimetres*

**Key**

- 1 Interchangeable steel plate with a thickness of 1,5 mm
- 2 Aluminium plates with a thickness of 8 mm
- 3 Mounting plate
- 4 Cut-out for the circuit-breaker in the steel plate

NOTE In particular cases the dimensions may be increased.

**Figure 14 – Example of mounting of a panel board type circuit-breaker for mechanical impact test (9.13.2)**

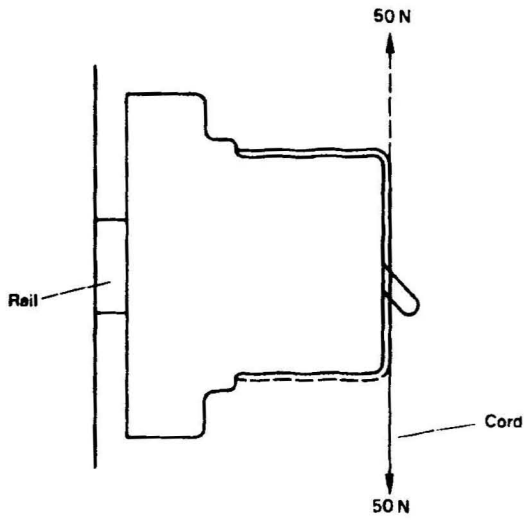

**Figure 15 – Application of force for mechanical test on a rail-mounted circuit-breaker (9.13.2.3)**

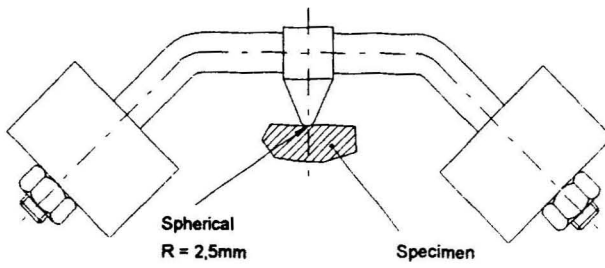

**Figure 16 – Ball-pressure test apparatus**

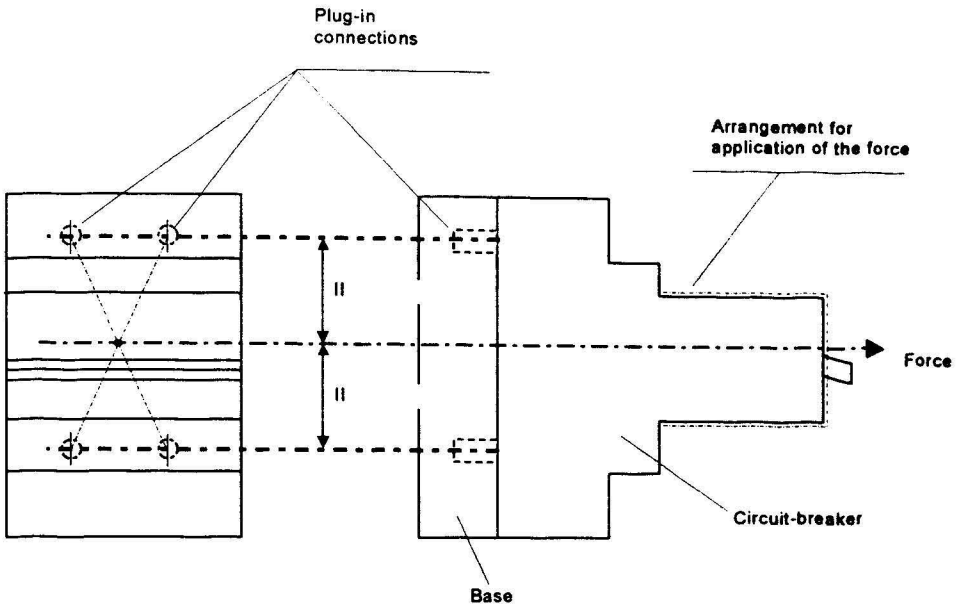

**Figure 17 – Example of application of force for mechanical test on two-pole plug-in circuit-breaker, the holding in position of which depends solely on the plug-in connections (9.13.2.4)**

**Annex A**  
(informative)

**Determination of short-circuit power factor**

There is no method by which the short-circuit power factor can be determined with precision, but for the purpose of the present standard the power factor of the test circuit may be determined by one of the following methods:

*Method 1 – Determination from d.c. component*

The angle  $\varphi$  may be determined from the curve of the d.c. component of the asymmetrical current wave between the instant of the short-circuit and the instant of contact separation as follows:

a) The formula for the d.c. component is:

$$i_d = I_{d0} \cdot e^{-Rt/L}$$

where:

- $i_d$  is the value of the d.c. component at the instant  $t$ ;
- $I_{d0}$  is the value of the d.c. component at the instant taken as time origin;
- $L/R$  is the time-constant of the circuit, in seconds;
- $t$  is the time, in seconds, taken from the initial instant;
- $e$  is the base of Napierian logarithms

The time-constant  $L/R$  can be ascertained from the above formula as follows:

- measure the value of  $I_{d0}$  at the instant of short-circuit and the value of  $i_d$  at another instant  $t$  before contact separation;
- determine the value of  $e^{-Rt/L}$  by dividing  $i_d$  by  $I_{d0}$ ;
- from a table of values of  $e^{-x}$ , determine the value of  $-x$  corresponding to the ratio  $i_d/I_{d0}$
- the value  $x$  represents  $Rt/L$ , from which  $L/R$  is obtained.

b) Determine the angle  $\varphi$  from:

$$\varphi = \arctan \omega L/R$$

where  $\omega$  is  $2\pi$  times the actual frequency.

This method should not be used when the currents are measured by current transformers.

*Method 2 – Determination with pilot generator*

When a pilot generator is used on the same shaft as the test generator, the voltage of the pilot generator on the oscillogram may be compared in phase first with the voltage of the test generator and then with the current of the test generator.

The difference between the phase angles between pilot generator voltage and main generator voltage on the one hand and pilot generator voltage and test generator current on the other hand gives the phase angle between the voltage and current of the test generator, from which the power factor can be determined.

**Annex B**  
(normative)

**Determination of clearances and creepage distances**

In determining clearances and creepage distances, it is recommended that the following points be considered.

If a clearance or creepage distance is influenced by one or more metal parts, the sum of the sections should have at least the prescribed minimum value.

Individual sections less than 1 mm in length should not be taken into consideration in the calculation of the total length of clearances and creepage distances.

In determining creepage distances:

- grooves at least 1 mm wide and 1 mm deep should be measured along their contour;
- grooves having any dimension less than these dimensions should be neglected;
- ridges at least 1 mm high:
  - are measured along their contour, if they are integral parts of a component of insulating material (for instance by moulding, welding or cementing);
  - are measured along the shorter of the two following paths: along the joint or along the profile of the ridge, if the ridges are not integral parts of a component of insulating material.

The application of the foregoing recommendations is illustrated by the following figures:

- figures B.1a, B.1b and B.1c indicate the inclusion or exclusion of a groove in a creepage distance;
- figures B.1d and B.1e indicate the inclusion or exclusion of a ridge in a creepage distance;
- figure B.1f indicates the consideration of the joint when the ridge is formed by an inserted insulating barrier, the outside profile of which is longer than the length of the joint;
- figures B.2a, B.2b, B.2c and B.2d illustrate how to determine the creepage distance in the case of fixing means situated in recesses in insulating parts of insulating material.

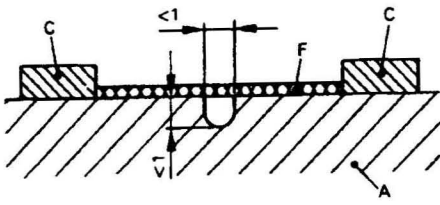

Figure B.1a

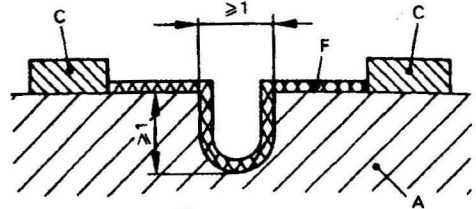

Figure B.1b

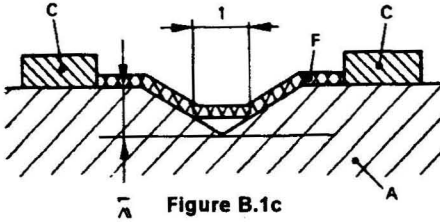

Figure B.1c

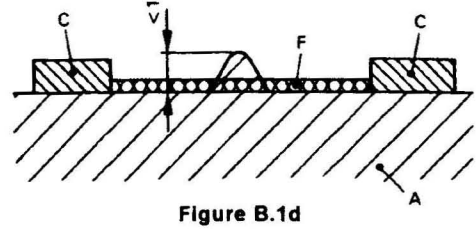

Figure B.1d

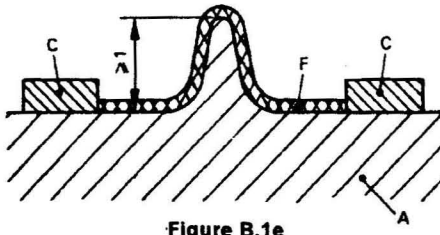

Figure B.1e

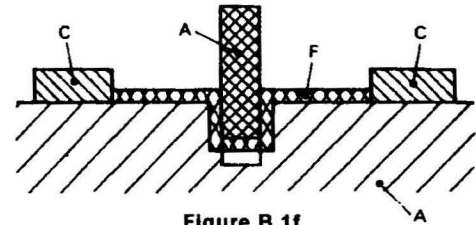

Figure B.1f

Dimensions in millimetres

Figure B.1 – Illustrations of the application of the recommendations for creepage distances

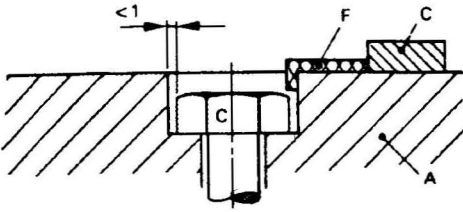

Figure B.2a

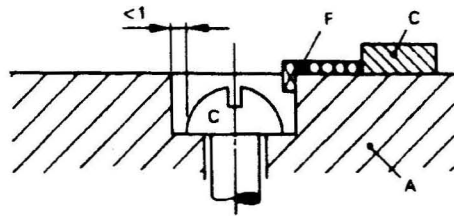

Figure B.2b

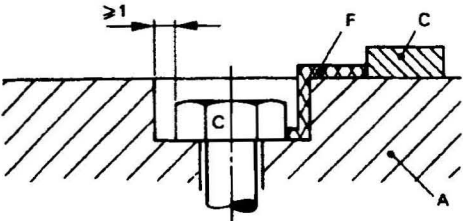

Figure B.2c

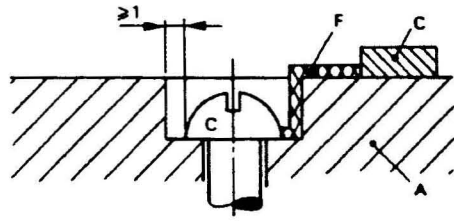

Figure B.2d

*Dimensions in millimetres*

**Figure B.2 – Illustrations of the application of the recommendations for creepage distances**



Annex C  
(normative)

**Number of samples to be submitted and test sequences to be applied for verification of conformity (13.5 of ISO/IEC Guide 2:1991)**

NOTE The verification may be made:

- by the manufacturer for the purpose of supplier's declaration of conformity (13.5.1 of ISO/IEC Guide 2:1991), or
  - by an independent body for the purpose of certification (13.5.2 of ISO/IEC Guide 2:1991).
- According to the terminology of ISO/IEC Guide 2, the term "certification" can be used for the second case only.

**C.1 Test sequences**

The tests are made according to table C.1 where the tests in each sequence are carried out in the order indicated.

**Table C.1 – Test sequences**

Test sequence	Clause or subclause	Test (or inspection)	
A	6	Marking	
	8.1.1	General	
	8.1.2	Mechanism	
	9.3	Indelibility of marking	
	8.1.3	Clearances and creepage distances (external parts only)	
	8.1.6	Non-interchangeability	
	9.4	Reliability of screws, current-carrying parts and connections	
	9.5	Reliability of screw-type terminals for external conductors	
	9.6	Protection against electric shock	
	8.1.3	Clearances and creepage distances (internal parts only)	
	9.14	Resistance to heat	
	9.15	Resistance to abnormal heat and to fire	
9.16	Resistance to rusting		
B	9.7	Dielectric properties	
	9.8	Temperature rise	
	9.9	28-day test	
C	C <sub>1</sub>	9.11	Mechanical and electrical endurance
		9.12.11.2.1	Performance at reduced short-circuit currents
		9.12.12	Verification of the circuit-breaker after short-circuit tests
	C <sub>2</sub>	9.12.11.2.2	Short-circuit test for verifying the suitability of circuit-breakers for use in IT systems
9.12.12		Verification of the circuit-breaker after short-circuit tests	
D	D <sub>0</sub>	9.10	Tripping characteristic
	D <sub>1</sub>	9.13	Resistance to mechanical shock and impact
		9.12.11.3 and 9.12.12	Short-circuit performance at 1 500 A Verification of circuit-breaker after short-circuit tests
E	E <sub>1</sub>	9.12.11.4.2 and 9.12.12	Service short-circuit capacity ( $I_{CS}$ ) Verification of circuit-breaker after short-circuit tests
		9.12.11.4.3 and 9.12.12	Performance at rated short-circuit capacity ( $I_{CN}$ ) Verification of circuit-breaker after short-circuit tests

NOTE With the agreement of the manufacturer the same samples may be used for more than one test sequence.

## C.2 Number of samples to be submitted for full test procedure and acceptance criteria

If only one rating (i.e. one set of rated quantities, see 5.2) of one type (number of poles, instantaneous tripping) of circuit-breaker is submitted for test, the number of samples to be submitted to the different test sequences are those indicated in table C.2 in which the acceptance criteria are given.

If all the samples submitted according to the second column of table C.2 pass the tests, compliance with the standard is met. If only the minimum number given in the third column passes the tests, additional samples as shown in the fourth column shall be tested and shall satisfactorily complete the test sequence.

For circuit-breakers having more than one rated current, two separate sets of circuit-breakers shall be submitted to each test sequence: one set adjusted at the maximum rated current, the other set at the minimum rated current. In addition one sample of all other rated currents shall be submitted for test sequence D<sub>0</sub> of table C.1.

**Table C.2 – Number of samples for full test procedure**

Test sequence	Number of samples	Minimum number of samples which shall pass the tests a b	Number of samples for repeated tests c
A	1	1	–
B	3	2	3
C	C <sub>1</sub>	2 <sup>e</sup>	3
	C <sub>2</sub> <sup>f</sup>	2 <sup>e</sup>	3
D	3	2 <sup>e</sup>	3
E <sub>1</sub>	3 + 4 <sup>d</sup>	2 <sup>e</sup> + 2 <sup>d.e</sup>	3 + 4 <sup>d</sup>
E <sub>2</sub>	3 + 4 <sup>d</sup>	2 <sup>e</sup> + 3 <sup>d.e</sup>	3 + 4 <sup>d</sup>

<sup>a</sup> In total, a maximum of two test sequences may be repeated.  
<sup>b</sup> It is assumed that a sample which has not passed a test has not met the requirements due to workmanship or assembly defects which are not representative of the design.  
<sup>c</sup> In the case of repeated tests, all results shall be acceptable.  
<sup>d</sup> Supplementary samples in the case of single-pole circuit-breakers rated 230/400 V or 240/415 V (see table 1).  
<sup>e</sup> All samples shall meet the test requirements of 9.12.10, 9.12.11.2, 9.12.11.3 and 9.12.11.4, as appropriate.  
<sup>f</sup> For this sequence read "number of protected poles" instead of "number of samples".

### **C.3 Number of samples to be submitted for simplified test procedure**

This clause applies when submitting simultaneously a range of circuit-breakers of the same fundamental design.

**C.3.1** For a series of circuit-breakers of the same fundamental design, the number of samples to be tested may be reduced according to C.3.2 and C.3.3.

For subsequent additions (e.g. further values of rated currents, different classification of instantaneous tripping, different number of poles) to such a series of circuit-breakers the same reductions apply.

**NOTE** When a series of circuit-breakers presenting minor variations with respect to an already approved series of circuit-breakers is submitted to type tests, a further reduction of the number of samples and tests may be agreed upon.

Circuit-breakers can be considered to be of the same fundamental design if the following conditions are met:

- they have the same basic design;
- they have the same external physical dimensions per pole;
- the materials, finish and dimensions of the internal current carrying parts are identical, other than the variations given in a) below;
- the terminals are of similar design, (see d) below);
- the contact size, material, configuration and method of attachment are identical;
- the manual operating mechanisms (materials and physical characteristics) are identical;
- the moulding and insulating materials are identical;
- the method, materials and construction of the arc extinction device are identical;
- the basic design of the overcurrent tripping device is identical, other than the variations given in b) below;
- the basic design of the instantaneous tripping device is identical, other than the variations given in c) below;
- their voltage rating is intended for the same type of distribution circuit (see table 1);
- multipole circuit-breakers are either composed of single-pole circuit-breakers or built up from the same components as the single-pole circuit-breakers, having the same overall dimensions per pole, with the exception of external barriers between poles.

The following variations are permitted:

- a) cross-sectional areas of the internal current-carrying connections;
- b) dimensions and material of the overcurrent tripping device;
- c) number of turns and cross-sectional area of the operating coil of the instantaneous tripping device;
- d) dimensions of terminals.

C.3.2 For circuit-breakers having the same instantaneous tripping classification according to 4.5 the number of samples to be tested may be reduced, according to table C.3.

Table C.3 – Reduction of samples for series of circuit-breakers having different numbers of poles

Test sequence	Number of samples depending on number of poles <sup>a</sup>			
	One pole <sup>b</sup>	Two poles <sup>c</sup>	Three poles <sup>d</sup>	Four poles <sup>e</sup>
A	1 maximum rated current	1 maximum rated current <sup>g, i</sup>	1 maximum rated current <sup>i</sup>	1 maximum rated current <sup>i</sup>
B	3 maximum rated current	3 maximum rated current <sup>g</sup>	3 maximum rated current	3 maximum rated current
C	C <sub>1</sub>	3 maximum rated current	3 maximum rated current <sup>g</sup>	3 maximum rated current
	C <sub>2</sub>	3 maximum rated current	2 maximum rated current for 2 protected poles, or 3 maximum rated current for one protected pole	1 maximum rated current
D <sub>0</sub> + D <sub>1</sub>	3 maximum rated current	3 maximum rated current <sup>h</sup>	3 maximum rated current	3 maximum rated current
D <sub>0</sub>	1 of all other rated currents			
E <sub>1</sub>	3+4 <sup>f</sup> maximum rated current	3 maximum rated current	3 maximum rated current	3 maximum rated current
	3+4 <sup>f</sup> minimum rated current	3 minimum rated current	3 minimum rated current	3 minimum rated current
E <sub>2</sub>	3+4 <sup>f</sup> maximum rated current	3 maximum rated current	3 maximum rated current	3 maximum rated current
	3+4 <sup>f</sup> minimum rated current	3 minimum rated current	3 minimum rated current	3 minimum rated current

<sup>a</sup> If a test is to be repeated according to the acceptance criteria of C.2, a new set of samples is used for the relevant test sequence. In repeated tests all results shall be satisfactory.

<sup>b</sup> If only multipole circuit-breakers are submitted, this column applies to the set of samples having the smallest number of poles (instead of the relevant column).

<sup>c</sup> Applicable to two-pole circuit-breakers whether with two protected poles or with one protected pole.

<sup>d</sup> This series is omitted when four-pole circuit-breakers are also tested.

<sup>e</sup> Also applicable to circuit-breakers with three protected poles and a neutral pole.

<sup>f</sup> Supplementary samples in case of single-pole circuit-breakers of 5.3.1.4.

<sup>g</sup> This test sequence is omitted when three-pole or four-pole circuit-breakers have been tested.

<sup>h</sup> This test sequence shall be omitted for two-pole circuit breakers with two protected poles, when three-pole or four-pole circuit-breakers have been tested.

<sup>i</sup> When multipole circuit-breakers are submitted, a maximum of four screw-type terminals for external conductors are subjected to the tests of 9.5, i.e. two supply and two load terminals.

**C.3.3** For an additional series of circuit-breakers of the same fundamental design as described in C.3.1 but of a different instantaneous tripping classification according to 4.5 the test sequences to be applied may be limited to those given in table C.4, the number of samples being those given in table C.3.

**Table C.4 – Test sequences for a series of circuit-breakers being of different instantaneous tripping classifications**

Circuit-breaker type-tested first	Subsequent test sequences for circuit-breakers of		
	E-type	C-type	D-type
B-type	–	$(D_0 + D_1) + E$	$(D_0 + D_1) + E$
C-type	$D_0^a + B^a$		$(D_0 + D_1) + E$
D-type	$D_0^a + B^a$	$D_0^a + B^{a\ b}$	–

<sup>a</sup> For these test sequences only the tests of 9.8 and 9.10.2 are required.

<sup>b</sup> When certification is requested at the same time for B-type, C-type and D-type circuit-breakers having the same rated short-circuit capacity, only test sequence  $D_0$  is required if B-type and D-type samples have been tested.

## Annex D (informative)

### Co-ordination under short-circuit conditions between a circuit-breaker and another short-circuit protective device (SCPD) associated in the same circuit

#### D.1 Introduction

To ensure co-ordination under short-circuit conditions between a circuit-breaker ( $C_1$ ) and another short-circuit protective device (SCPD) associated with it in the same circuit, it is necessary to consider the characteristics of each of the two devices as well as their behaviour as an association.

NOTE An SCPD may incorporate additional protective means, for example overload releases.

The SCPD may consist of a fuse (or a set of fuses) – see figure D.1 – or another circuit-breaker ( $C_2$ ) (see figures D.2 and D.3).

The comparison of the individual operating characteristics of each of the two associated devices may not be sufficient, when reference has to be made to the behaviour of these two devices operating in series, since the impedance of the devices is not always negligible. It is recommended that this should be taken into account. For short-circuit currents it is recommended that reference be made to  $I^2t$  instead of time.

$C_1$  is frequently connected in series with another SCPD for reasons such as the method of power distribution adopted for the installation or because the short-circuit capacity of  $C_1$  alone may be insufficient for the proposed application. In such instances the SCPD may be mounted in locations remote from  $C_1$ . The SCPD may be protecting a main feeder supplying a number of circuit-breakers  $C_1$  or just an individual circuit-breaker.

For such applications the user or specifying authority may have to decide, on the basis of a desk study alone, how the optimum level of co-ordination may best be achieved. This annex is intended to give guidance for this decision, and also on the type of information which the circuit-breaker manufacturer should make available to the prospective user.

Guidance is also given on test requirements, where such tests are deemed necessary for the proposed application.

The term "co-ordination" includes consideration of discrimination (see 3.5.14.2 and also 3.5.14.4 and 3.5.14.5) as well as consideration of back-up protection (see 3.5.14.3).

Consideration of discrimination can in general be carried out by desk study (see D.5) whereas the verification of back-up protection normally requires the use of tests (see D.6).

When considering short-circuit breaking capacity, reference is made to the rated short-circuit capacity ( $I_{cn}$ ) of  $C_1$  and  $C_2$  when both are circuit-breakers according to IEC 60898-1, and to the ultimate short-circuit breaking capacity ( $I_{cu}$ ) of  $C_2$ , when  $C_2$  is a circuit-breaker according to IEC 60947-2.

## **D.2 Scope and object**

This annex gives guidance on and requirements for the co-ordination of a circuit-breaker with other SCPDs associated in the same circuit, as regards discrimination as well as back-up protection.

The object of this annex is to state

- the general requirements for the co-ordination of a circuit-breaker with another SCPD;
- the methods and the tests (if deemed necessary) intended to verify that the conditions for co-ordination have been met.

## **D.3 General requirements for the co-ordination of a circuit-breaker with another SCPD**

### **D.3.1 General consideration**

Ideally, the co-ordination should be such that a circuit-breaker ( $C_1$ ) alone will operate at all values of overcurrent up to the limit of its rated short-circuit capacity  $I_{cn}$ .

**NOTE** If the value of the prospective fault current at the point of installation is less than the rated short-circuit capacity of  $C_1$ , it may be assumed that the SCPD is only in the circuit for considerations other than that of back-up protection.

In practice the following considerations apply:

- a) if the value of the selectivity limit current  $I_s$  (see 3.5.14.6) is too low, there is a risk of unnecessary loss of discrimination;
- b) if the value of the prospective fault current at the point of installation exceeds the rated short-circuit capacity of  $C_1$ , the SCPD shall be so selected that the behaviour of  $C_1$  is in accordance with D.3.3 and the take-over current  $I_B$  (see 3.5.14.7), if any, complies with the requirements of D.3.2.

Whenever possible, the SCPD shall be located on the supply side of  $C_1$ . If the SCPD is located on the load side, it is essential that the connection between  $C_1$  and the SCPD be so arranged as to minimize any risk of short-circuit.

### **D.3.2 Take-over current**

For the purpose of back-up protection the take-over current  $I_B$  shall not exceed the rated short-circuit capacity  $I_{cn}$  of  $C_1$  alone (see figure D.3a).

### **D.3.3 Behaviour of $C_1$ in association with another SCPD**

For all values of overcurrent up to and including the short-circuit capacity of the association,  $C_1$  and the association shall comply with the requirements of 8.8.

## **D.4 Type and characteristics of the associated SCPD**

On request, the manufacturer of the circuit-breaker shall provide information on the type and the characteristics of the SCPD to be used with  $C_1$ , and on the maximum prospective short-circuit current for which the association is suitable at the stated operational voltage.

Details of the SCPD used for any tests made in accordance with this annex, i.e. manufacturer's name, type designation, rated voltage, rated current and short-circuit breaking capacity, shall be given in the test report.

The maximum conditional short-circuit current  $I_{nc}$  (see 3.5.14.8) shall not exceed

- the rated ultimate breaking capacity of the SCPD, if this is a circuit-breaker according to IEC 60947-2;
- the rated short-circuit capacity, if the SCPD is a circuit-breaker according to this standard;
- the rated short-circuit breaking capacity, if the SCPD is a fuse.

If the associated SCPD is a circuit-breaker, it shall meet the requirements of this standard, or any other relevant standard.

If the associated SCPD is a fuse, it shall be in accordance with IEC 60269 or with any other fuse standard.

## D.5 Verification of discrimination

Discrimination can normally be considered by desk study alone, i.e. by a comparison of the operating characteristics of  $C_1$  and the associated SCPD, for example when the associated SCPD is a circuit-breaker ( $C_2$ ) provided with an intentional time-delay.

The manufacturers of both the  $C_1$  and the SCPD shall provide adequate data concerning the relevant operating characteristics as to permit  $I_s$  to be determined for each individual association.

In certain cases, tests at  $I_s$  are necessary on the association, for example:

- when  $C_1$  is of the current limiting type and  $C_2$  is not provided with an intentional time-delay;
- when the opening time of the SCPD is less than that corresponding to one half-cycle.

To obtain the desired discrimination when the associated SCPD is a circuit-breaker, an intentional short-time delay may be necessary for  $C_2$ .

Discrimination may be partial (see figure D.3a) or total up to the rated short-circuit capacity  $I_{cn}$  of  $C_1$ . For total discrimination, the non-tripping characteristic of  $C_2$  or the pre-arcing characteristic of the fuse shall lie above the tripping (break time) characteristic of  $C_1$ .

Two illustrations of total discrimination are given in figures D.2a and D.2b.

## D.6 Verification of back-up protection

### D.6.1 Determination of the take-over current

Compliance with the requirements of D.3.2 can be checked by comparing the operating characteristics of  $C_1$  with those of the associated SCPD for all settings (if any) of  $C_2$ .

### D.6.2 Verification of back-up protection

#### D.6.2.1 Verification by tests

Compliance with the requirements of D.3.3 is normally verified by tests in accordance with D.6.3. In this case, all conditions for the tests shall be as specified in 9.12.11.4.3 with the adjustable resistors and inductors for the short-circuit tests on the supply side of the association.

NOTE An example of a test circuit is given in IEC 60947-2, Figure A.6.



**D.6.2.2 Verification by comparison of characteristics**

In some practical cases and where the SCPD is a circuit-breaker (see figure D.3a and D.3b), it may be possible to compare the operating characteristics of  $C_1$  and of the associated SCPD, special attention being paid to the following:

- the Joule integral value of  $C_1$  at its  $I_{cn}$  and that of SCPD at the prospective current of the association;
- the effects on  $C_1$  (e.g. by arc energy, maximum peak current, cut-off current) at the peak operating current of the SCPD.

The suitability of the association may be evaluated by considering the maximum operating  $I^2t$  characteristic of the SCPD, over the range from the rated short-circuit capacity  $I_{cn}$  of  $C_1$  up to the prospective short-circuit current of the application, but not exceeding the maximum let-through  $I^2t$  of  $C_1$  at its rated short-circuit capacity or other lower limiting value stated by the manufacturer.

**NOTE** Where the associated SCPD is a fuse, the validity of the desk study is limited to  $I_{cn}$  of  $C_1$ .

**D.6.3 Tests for verification of back-up protection**

If the associated SCPD is a circuit-breaker ( $C_2$ ) fitted with adjustable overcurrent opening releases, the operating characteristics to be used shall be those corresponding to the maximum time and maximum current settings.

If the associated SCPD consists of a set of fuses, each test shall be made using a new set of fuses, even if some of the fuses used during a previous test have not blown.

Where applicable, the connecting cables shall be included as specified in 9.12.4 except that, if the associated SCPD is a circuit-breaker ( $C_2$ ), the full length of cable (75 cm) associated with this circuit-breaker may be on the supply side.

Each test shall consist of a O-t-CO sequence of operation made in accordance with 9.12.11.4.3 at  $I_{cn}$ , the CO operation being made on  $C_1$ .

A test is made with the maximum prospective current for the proposed application. This shall not exceed the rated conditional short-circuit current (see 3.5.14.9).

A further test shall be made at a value of prospective current equal to the rated short-circuit breaking capacity  $I_{cn}$  of  $C_1$ , for which test a new sample  $C_1$  may be used, and also, if the associated SCPD is a circuit-breaker, a new sample  $C_2$ .

During each operation

- a) if the associated SCPD is a circuit-breaker ( $C_2$ ):
- either both  $C_1$  and  $C_2$  shall trip at both test currents, no further tests then being required.

This is the general case in which back-up protection only is provided.

- or  $C_1$  shall trip and  $C_2$  shall be in the closed position at the end of each operation, at both test currents, no further tests then being required.

This requires that the contacts of  $C_2$  separate momentarily during each operation. In this case restoration of the supply is provided, in addition to back-up protection (see note 1 to figure D.3a). The duration of interruption of supply, if any, shall be recorded during these tests.

- or  $C_1$  shall trip at the lower test current, and both  $C_1$  and  $C_2$  shall trip at the higher test current.

This requires that the contacts of  $C_2$  separate momentarily at the lower test current. Additional tests shall be made at intermediate currents to determine the lowest current at which both  $C_1$  and  $C_2$  trip, up to which current restoration of supply is provided. The duration of interruption of supply, if any, shall be recorded during these tests.

- b) if the associated SCPD is a fuse (or a set of fuses):
- for the test at the rated conditional short-circuit current
    - in case of a single-phase circuit at least one fuse shall blow;
    - in case of a multi-phase circuit either two or more fuses shall blow, or one fuse shall blow and  $C_1$  shall trip;
  - for the test at the rated short-circuit breaking capacity  $C_1$  shall trip and at least one fuse shall blow.

#### **D.6.4 Results to be obtained**

Following the tests,  $C_1$  shall comply with 9.12.12.2.

In addition, if the associated SCPD is a circuit-breaker ( $C_2$ ), it shall be verified, by manual operation or other appropriate means, that the contacts of  $C_2$  have not welded.

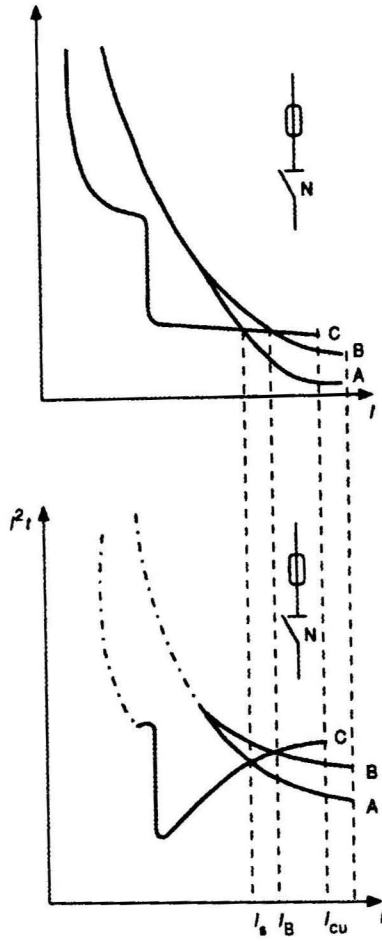

**Key**

- $I$  = Prospective short-circuit current
- $I_{cn}$  = Rated short-circuit capacity (5.2.4)
- $I_s$  = Selectivity limit current (3.5.14.5)
- $I_B$  = Take-over current (3.5.14.7)
- A = Pre-arcing characteristic of the fuse
- B = Operating characteristic of the fuse
- C = Operating characteristic of the circuit-breaker, non-current-limiting (N) (break-time/current and  $I^2t$ /current)

NOTE 1 A is deemed to be the lower limit; B and C are deemed to be the upper limits.

NOTE 2 Non-adiabatic zone for  $I^2t$  shown chain-dotted.

**Figure D.1 – Overcurrent co-ordination between a circuit-breaker and a fuse or back-up protection by a fuse – Operating characteristics**

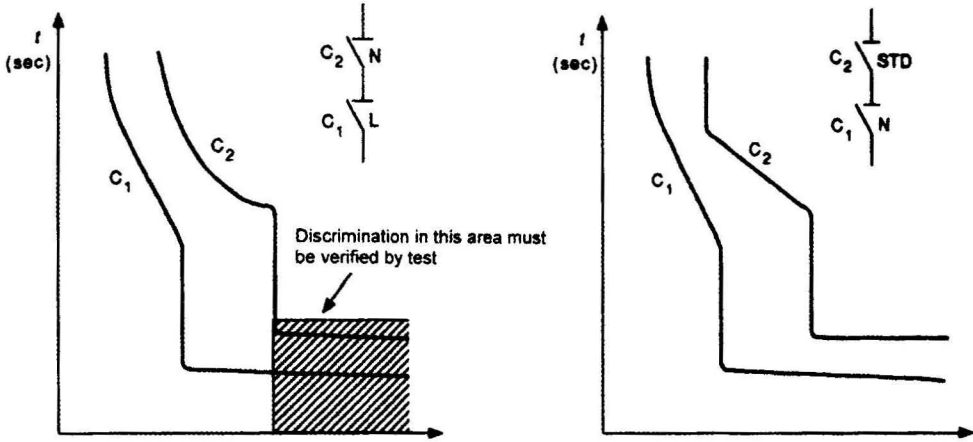

**Key**

$C_1$  = Current-limiting circuit-breaker (L)  
(break-time characteristic)

$C_2$  = Non-current-limiting circuit breaker (N)  
(tripping characteristic)

$C_1$  = Non-current-limiting circuit-breaker (N)  
(break-time characteristic)

$C_2$  = Circuit-breaker with intentional short-time  
delay (STD) (tripping characteristic)

NOTE Values of  $I_{cn}$  are not shown.

Figure D.2a

Figure D.2b

**Figure D.2 – Total discrimination between two circuit-breakers**

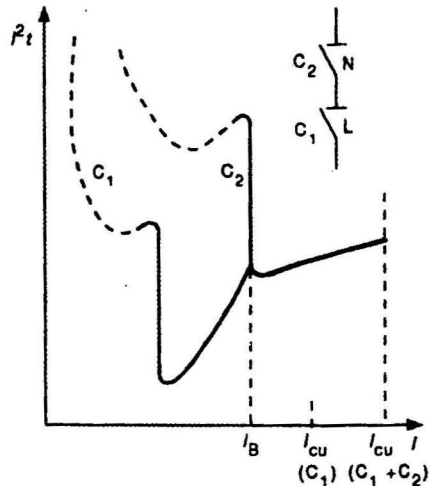
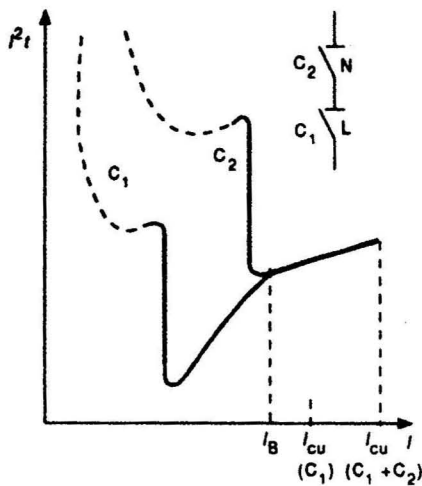
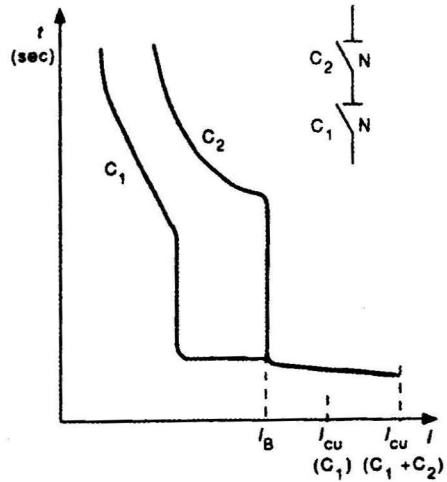
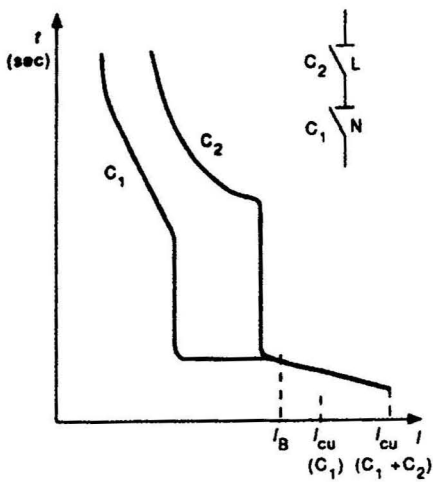

**Key**

C<sub>1</sub> = Non current-limiting circuit-breaker (N)

C<sub>1</sub>, C<sub>2</sub> = Non current-limiting circuit-breaker (N)

C<sub>2</sub> = Current-limiting circuit breaker (L)

$I_B$  = Take-over current

NOTE 1 Where applicable, restoration of supply by C<sub>2</sub> occurs.

NOTE 2  $I_{cn}(C_1 + C_2) \leq I_{cn}(C_2)$ .

NOTE 3 For values of  $I > I_B$ , the curve is that of the association (shown in bold) for which data must be obtained by tests.

Figure D.3a

Figure D.3b

**Figure D.3 – Back-up protection by a circuit-breaker – Operating characteristics**

**Annex E**  
(normative)

**Special requirements for auxiliary circuits for safety extra-low voltage**

**8.1.3 Clearances and creepage distances**

*Add the following note to table 4:*

5) Live parts in auxiliary circuits intended to be connected to safety extra-low voltages shall be separated from circuits with higher voltages in accordance with the requirements of 411.1.3.3 of IEC 60364-4-41.

**9.7.4 Dielectric strength of the auxiliary circuits**

Add the following note:

NOTE A test for circuits intended for connection to safety extra-low voltage is under consideration.

**9.7.5 Values of test voltage**

*Add the following note under item b):*

NOTE The values of the test voltages for circuits intended for connection to safety extra-low voltage are under consideration.

**Annex F**  
(informative)

**Examples of terminals**

In this annex some examples of designs of terminals are given. The conductor location must have a diameter suitable for accepting solid rigid conductors and a cross-sectional area suitable for accepting rigid stranded conductors (see 8.1.5).

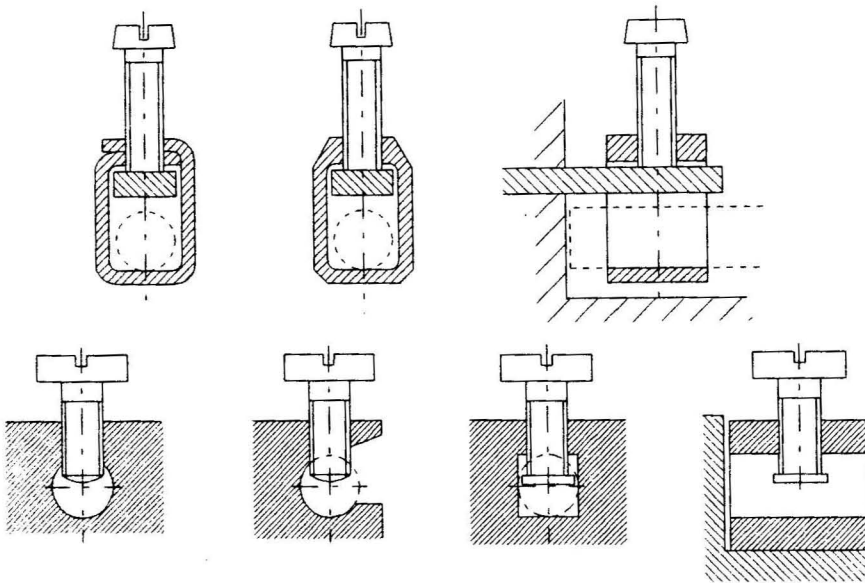

The part of the terminal containing the threaded hole and the part of the terminal against which the conductor is clamped by the screw may be two separate parts, as in the case of a terminal provided with a stirrup.

**Figure F.1 – Examples of pillar terminals**

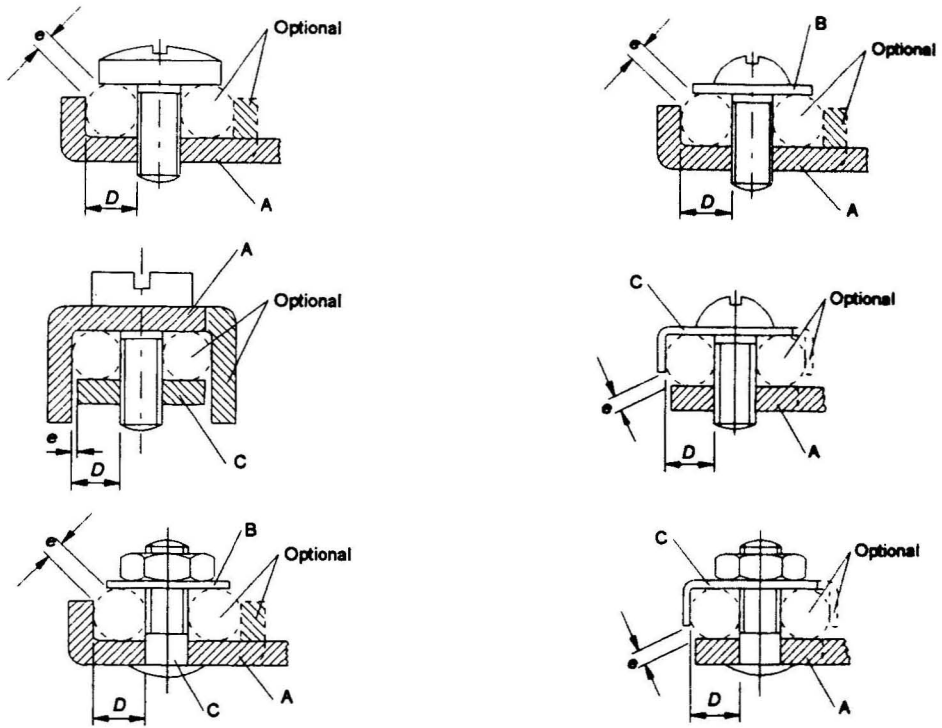

The part which retains the conductor in position may be of insulating material, provided the pressure necessary to clamp the conductor is not transmitted through the insulating material.

**Figure F.2 – Examples of screw terminals and stud terminals**



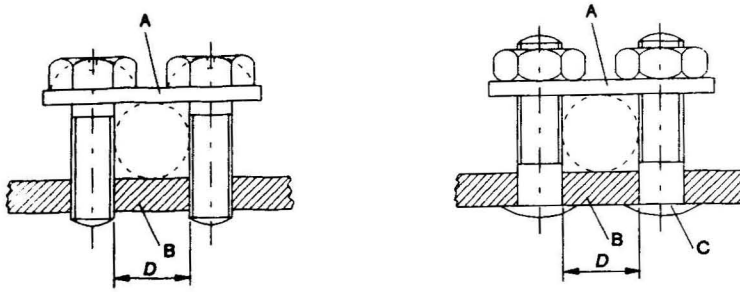

**Key**

A Saddle

B Fixed part

C Stud

D Conductor space

The two faces of the saddle may be of different shapes to accommodate conductors of either small or large cross-sectional area, by inverting the saddle.

The terminals may have more than two clamping screws or studs.

**Figure F.3 – Examples of saddle terminals**

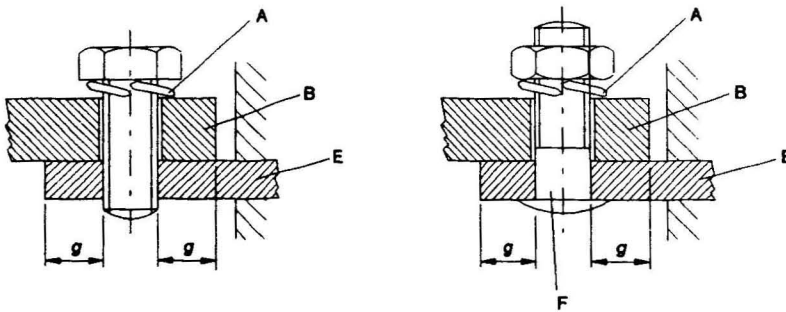

**Key**

A Locking means

B Cable lug or bar

E Fixed part

F Stud

For this type of terminal, a spring washer or equally effective locking means shall be provided and the surface within the clamping area shall be smooth.

For certain types of equipment, the use of lug terminals of sizes smaller than that required is allowed.

**Figure F.4 – Examples of lug terminals**

**Annex G**  
(informative)

**Correspondence between ISO and AWG copper conductors**

ISO size mm <sup>2</sup>	AWG	
	Size	Cross-section mm <sup>2</sup>
1,0	18	0,82
1,5	16	1,3
2,5	14	2,1
4,0	12	3,3
6,0	10	5,3
10,0	8	8,4
16,0	6	13,3
25,0	3	26,7
35,0	2	33,6
50,0	0	53,5

NOTE In general ISO sizes apply. Upon request of the manufacturer AWG sizes may be used.

**Annex H**  
**(normative)**

**Arrangement for short-circuit test**

The device under test is mounted as shown in figure H.1 which may require adapting to the specific design of the device, and in accordance with the manufacturer's instruction.

When required (i.e. during O operations), a clear polyethylene foil ( $0,05 \pm 0,01$ ) mm, of a size at least 50 mm larger in each direction, than the overall dimensions of the front face of the device, but not less than  $200 \times 200$  mm, is fixed and reasonably stretched in a frame, placed at a distance of 10 mm from

- either the maximum projection of the operating means of a device without recess for the operating means;
- or the rim of a recess for the operating means of a device with recess for the operating means.

The foil should have the following physical properties:

- density at 23 °C: ( $0,92 \pm 0,05$ ) g/cm<sup>3</sup>;
- melting point: (110 to 120) °C.

When required, a barrier of insulating material, at least 2 mm thick, is placed, as shown in figure H.1, between the arc vent and the polyethylene foil to prevent damage of the foil due to hot particles emitted from the arc vent.

When required, a grid, (or grids) according to figure H.2 is (are) placed at a distance of "a" (mm) from each arc vent of the device.

The grid circuit (see figure H.3) shall be connected to the points B or C or C', as applicable (see figures 3 to 6).

The parameters for the grid circuit(s) are as follows:

- resistor R': 1,5  $\Omega$ ;
- copper wire F': length 50 mm and diameter as specified in 9.12.9.1.

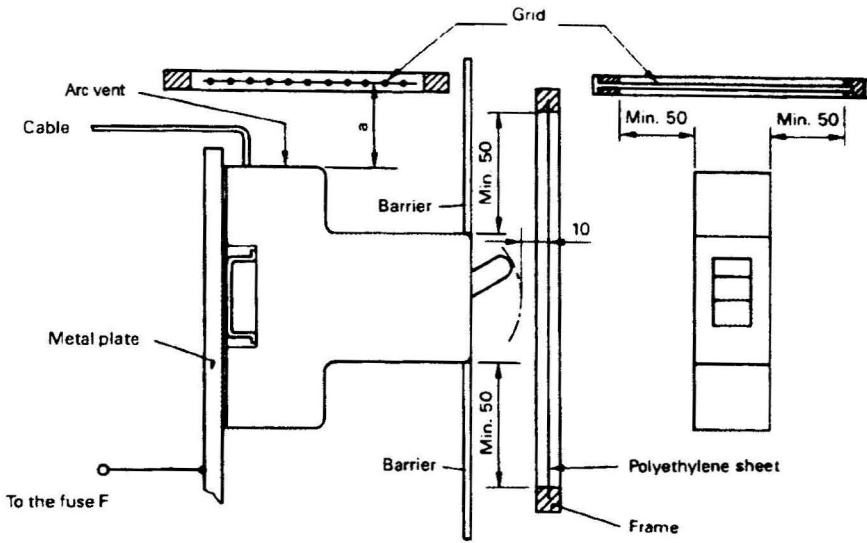

Dimensions in millimetres

Figure H.1 – Test arrangement

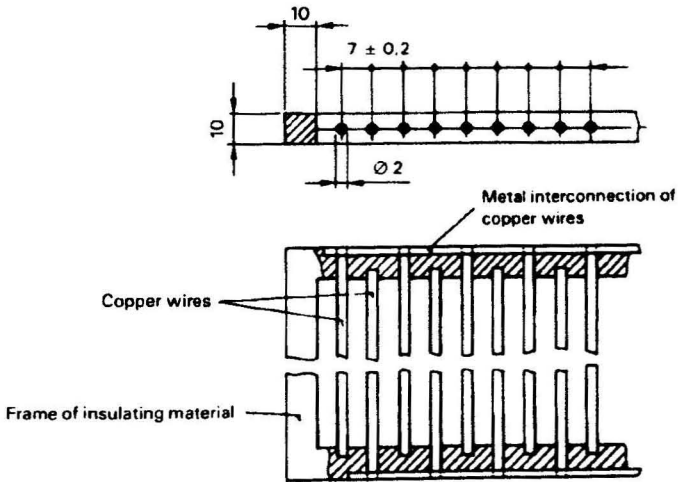

Dimension in millimetres

Figure H.2 – Grid circuit

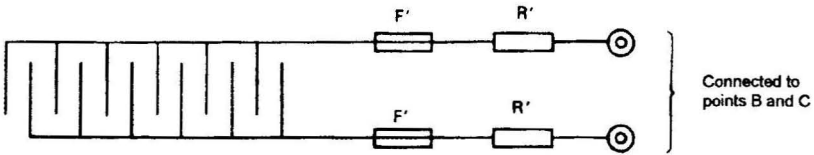

Figure H.3 – Grid circuit

## Annex I (normative)

### Routine tests

The tests specified in this annex are intended to reveal, as far as safety is concerned, unacceptable variations in material or manufacture.

Further tests may have to be made, according to the experience gained by the manufacturer, to ensure that every circuit-breaker is in conformity with the samples which passed the tests of this standard.

#### I.1 Tripping tests

##### *a) Verification of the time-current characteristic*

*A current of any convenient value between the conventional tripping current and the lower value of the range of instantaneous tripping of table 2 (according to the tripping characteristic of the circuit-breaker: B, C or D) is passed separately through each protected pole starting from cold.*

*The circuit-breaker shall trip within a time corresponding to a point, selected by the manufacturer, situated between the limiting times of the tripping characteristic.*

##### *b) Verification of the instantaneous tripping*

*Each circuit-breaker shall perform the tests of instantaneous tripping of 9.10.2 at the upper value of the test current, according to the type: B, C or D. The test is carried out at any convenient voltage.*

#### I.2 Verification of clearances between open contacts

*With the circuit-breaker in the open position a voltage of substantially sine-wave form of 1 500 V, having a frequency of 50 Hz or 60 Hz, is applied for 1 s between the terminals which are electrically connected together when the circuit-breaker is in the closed position.*

*No flashover or breakdown shall occur.*

*Alternatively any convenient method of verification of the clearances between open contacts (e.g. X-ray verification) may be used.*

**Annex J**  
(normative)

**Particular requirements for circuit-breakers with screwless type terminals for external copper conductors**

**J.1 Scope**

This annex applies to circuit-breakers within the scope of clause 1, equipped with screwless terminals, for current not exceeding 20 A primarily suitable for connecting unprepared (see J.3.6) copper conductors of cross-section up to 4 mm<sup>2</sup>.

NOTE In AT, CZ, DE, DK, NL, NO and CH the upper limit of current for use of screwless terminals is 16 A.

In this annex, screwless terminals are referred to as terminals and copper conductors are referred to as conductors.

**J.2 Normative references**

Clause 2 applies.

**J.3 Definitions**

As a complement to clause 3, the following definitions apply:

**J.3.1**

**clamping units**

parts of the terminal necessary for mechanical clamping and the electrical connection of the conductors including the parts which are necessary to ensure correct contact pressure

**J.3.2**

**screwless-type terminal**

terminal for the connection and subsequent disconnection obtained directly or indirectly by means of springs, wedges or the like

NOTE Examples are given in figure J 2 .

**J.3.3**

**universal terminal**

terminal for the connection and disconnection of all types of conductors (rigid and flexible)

NOTE In the following countries only universal screwless type terminals are accepted: AT, BE, CN, DK, DE, ES, FR, IT, PT, SE and CH.

**J.3.4**

**non-universal terminal**

terminal for the connection and disconnection of a certain kind of conductor only (e.g. rigid-solid conductors only or rigid-[solid or stranded] conductors only)

**J.3.5**

**push-wire terminal**

non-universal terminal in which the connection is made by pushing-in rigid (solid or stranded) conductors

**J.3.6**

**unprepared conductor**

conductor which has been cut and the insulation of which has been removed over a certain length for insertion into a terminal

NOTE 1 A conductor the shape of which is arranged for introduction into a terminal or of which the strands may be twisted to consolidate the end, is considered to be an unprepared conductor.

NOTE 2 The term "unprepared conductor" means conductor not prepared by soldering of the wire, use of cable lugs, formation of eyelets, etc., but includes its reshaping before introduction into the terminal or, in the case of flexible conductor, by twisting it to consolidate the end.

**J.4 Classification**

Clause 4 applies.

**J.5 Characteristics of circuit-breakers**

Clause 5 applies.

**J.6 Marking**

In addition to clause 6, the following requirements apply:

Universal terminals:

- no marking.

Non-universal terminals:

- terminals declared for rigid-solid conductors shall be marked by the letters "sol";
- terminals declared for rigid (solid and stranded) conductors shall be marked by the letter "r";
- terminals declared for flexible conductors shall be marked by the letter "f".

The markings should appear on the circuit-breaker or, if the space available is not sufficient, on the smallest package unit or in technical information .

An appropriate marking indicating the length of insulation to be removed before insertion of the conductor into the terminal shall be shown on the circuit-breaker.

The manufacturer shall also provide information, in his literature, on the maximum number of conductors which may be clamped.

**J.7 Standard conditions for operation in service**

Clause 7 applies.



**J.8 Constructional requirements**

Clause 8 applies, with the following modifications.

In 8.1.5 only 8.1.5.1, 8.1.5.2, 8.1.5.3, 8.1.5.6 and 8.1.5.7 apply.

*Compliance is checked by inspection and by the tests of J.9.1 and J.9.2 of this annex, instead of 9.4 and 9.5.*

In addition the following requirements apply.

**J.8.1 Connection or disconnection of conductors**

The connection or disconnection of conductors shall be made

- by the use of a general purpose tool or by a convenient device integral with the terminal to open it and to assist the insertion or the withdrawal of the conductors (e.g. for universal terminals);

or, for rigid conductors

- by simple insertion. For the disconnection of the conductors an operation other than a pull on the conductor shall be necessary (e.g. for push-wire terminals).

Universal terminals shall accept rigid (solid or stranded) and flexible unprepared conductors.

Non-universal terminals shall accept the types of conductors declared by the manufacturer.

*Compliance is checked by inspection and by the tests of J.9.1 and J.9.2.*

**J.8.2 Dimensions of connectable conductors**

The dimensions of connectable conductors are given in table J.1.

*The ability to connect these conductors shall be checked by inspection and by the tests of J.9.1 and J.9.2.*

Table J.1 – Connectable conductors

Connectable conductors and their theoretical diameter									
Metric					AWG				
Rigid			Flexible		Rigid			Flexible	
	Solid	Stranded				Solid <sup>a</sup>	Class B stranded <sup>a</sup>		Classes I, K, M, stranded <sup>b</sup>
mm <sup>2</sup>	Ø mm	Ø mm	mm <sup>2</sup>	Ø mm	gauge	Ø mm	Ø mm	gauge	Ø mm
1,0	1,2	1,4	1,0	1,5	18	1,02	1,16	18	1,28
1,5	1,5	1,7	1,5	1,8	16	1,29	1,46	16	1,60
2,5	1,9	2,2	2,5	2,3	14	1,63	1,84	14	2,08
4,0	2,4	2,7	4,0	2,9	12	2,05	2,32	12	2,70

NOTE Diameters of the largest rigid and flexible conductors are based on table 1 of IEC 60228A, and, for AWG conductors, on ASTM B 172-71, and ICEA publications S-19-81, S-66-524 and S-68-516.

<sup>a</sup> Nominal diameter + 5 %.

<sup>b</sup> Largest diameter + 5 % for any of the three classes I, K and M.

**J.8.3 Connectable cross-sectional areas**

The nominal cross-sections to be clamped are defined in table J.2.

Table J.2 – Cross-sections of copper conductors connectable to screwless-type terminals

Rated current A	Nominal cross-sections to be clamped mm <sup>2</sup>
Up to and including 13	1 up to and including 2,5
Above 13 up to and including 20	1,5 up to and including 4

Compliance is checked by inspection and by the tests of J.9.1 and J.9.2.

**J.8.4 Insertion and disconnection of conductors**

The insertion and disconnection of the conductors shall be made in accordance with the manufacturer's instructions.

Compliance is checked by inspection.

**J.8.5 Design and construction of terminals**

Terminals shall be so designed and constructed that:

- each conductor is clamped individually;
- during the operation of connection or disconnection the conductors can be connected or disconnected either at the same time or separately;
- inadequate insertion of the conductor is avoided.

It shall be possible to clamp securely any number of conductors up to the maximum provided for.

Compliance is checked by inspection and by the tests of J.9.1 and J.9.2.

**J.8.6 Resistance to ageing**

The terminals shall be resistant to ageing.

*Compliance is checked by the test of J.9.3.*

**J.9 Tests**

Clause 9 applies, by replacing 9.4 and 9.5 by the following tests:

**J.9.1 Test of reliability of screwless terminals**

**J.9.1.1 Reliability of screwless system**

*The test is carried out on three terminals of poles of new samples, with copper conductors of the rated cross sectional area in accordance with table J.2. The types of conductors shall be in accordance with J.8.1.*

*The connection and subsequent disconnection shall be made five times with the smallest diameter conductor and successively five times with the largest diameter conductor.*

*New conductors shall be used each time, except for the fifth time, when the conductor used for the fourth insertion is clamped at the same place. Before insertion into the terminal, wires of stranded rigid conductors shall be re-shaped and wires of flexible conductors shall be twisted to consolidate the ends.*

*For each insertion, the conductors are either pushed as far as possible into the terminal or shall be inserted so that adequate connection is obvious.*

*After each insertion, the conductor being inserted is rotated 90° along its axis at the level of the clamped section and subsequently disconnected.*

*After these tests, the terminal shall not be damaged in such a way as to impair its further use.*

**J.9.1.2 Test of reliability of connection**

*Three terminals of poles of new samples are fitted with new copper conductors of the type and of the rated cross sectional area according to table J.2.*

*The types of conductors shall be in accordance with J.8.1.*

*Before insertion into the terminal, wires of stranded rigid conductors and flexible conductors shall be reshaped and wires of flexible conductors shall be twisted to consolidate the ends.*

*It shall be possible to fit the conductor into the terminal without undue force in the case of universal terminals and with the force necessary by hand in the case of push-wire terminals.*

*The conductor is either pushed as far as possible into the terminal or shall be inserted so that adequate connection is obvious.*

*After the test, no wire of the conductor shall have escaped outside the terminal.*

**J.9.2 Tests of reliability of terminals for external conductors: mechanical strength**

*For the pull-out test three terminals of poles of new samples are fitted with new conductors of the type and of the minimum and maximum cross-sectional areas according to table J.2.*

*Before insertion into the terminal, wires of stranded rigid conductors and flexible conductors shall be reshaped and wires of flexible conductors shall be twisted to consolidate the ends.*

*Each conductor is then subjected to a pull force of the value shown in table J.3. The pull is applied without jerks for 1 min in the direction of the axis of the conductor.*

**Table J.3 – Pull forces**

Cross-sectional area mm <sup>2</sup>	Pull force N
1,0	35
1,5	40
2,5	50
4,0	60

*During the test the conductor shall not slip out of the terminal.*

**J.9.3 Cycling test**

*The test is made with new copper conductors having cross section according to table 9.*

*The test is carried out on new samples (a sample is one pole), the number of which is defined below, according to the type of terminals:*

- universal terminals for rigid (solid and stranded) and flexible conductors: 3 samples each (6 samples in total);*
  - non-universal terminals for solid conductors only: 3 samples;*
  - non-universal for rigid (solid and stranded) conductors: 3 samples each (6 samples);*
- NOTE In case of rigid conductors, solid conductors should be used (if solid conductors are not available in a given country, stranded conductors may be used).*
- non-universal for flexible conductors only: 3 samples.*

*A conductor having the cross section defined in table 9 is connected in series as in normal use to each of the three samples as defined on figure J.1.*

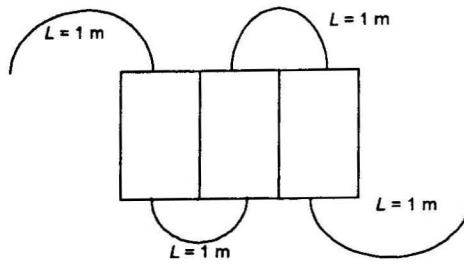

Figure J.1 – Connecting samples

*The sample is provided with a hole (or equivalent) in order to measure the voltage drop on the terminal.*

*The whole test arrangement, including the conductors, is placed in a heating cabinet which is initially kept at a temperature of  $(20 \pm 2) ^\circ\text{C}$ .*

*To avoid any movement of the test arrangement until all the following voltage drop tests have been completed it is recommended that the poles are fixed on a common support.*

*Except during the cooling period, a test current corresponding to the rated current of the circuit breaker is applied to the circuit.*

*The samples shall be then subjected to 192 temperature cycles, each cycle having a duration of approximately 1 h, as follows:*

*The air temperature in the cabinet is raised to  $40 ^\circ\text{C}$  in approximately 20 min. It is maintained within  $\pm 5 ^\circ\text{C}$  of this value for approximately 10 min.*

*The samples are then allowed to cool down in approximately 20 min to a temperature of approximately  $30 ^\circ\text{C}$ , forced cooling being allowed. They are kept at this temperature for approximately 10 min and, if necessary for measuring the voltage drop, allowed to cool down further, to a temperature of  $(20 \pm 2) ^\circ\text{C}$ .*

*The maximum voltage drop, measured at each terminal, at the end of the 192<sup>nd</sup> cycle, with the nominal current shall not exceed the smaller of the two following values:*

- either 22,5 mV,*
- or 1,5 times the value measured after the 24<sup>th</sup> cycle.*

*The measurement shall be made as near as possible to the area of contact on the terminal.*

*If the measuring points cannot be positioned closely to the point of contact, the voltage drop within the part of the conductor between the ideal and the actual measuring points shall be deducted from the voltage drop measured.*

*The temperature in the heating cabinet must be measured at a distance of at least 50 mm from the samples.*

After this test an inspection with the naked eye, by normal or corrected vision, without additional magnification, shall show no changes evidently impairing further use, such as cracks, deformations or the like.

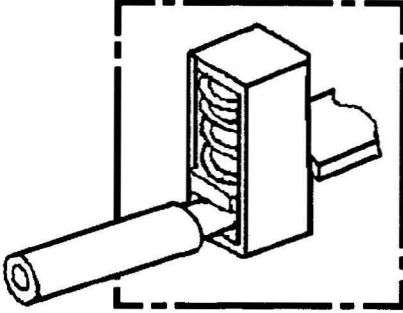

Screwless-type terminal with indirect pressure

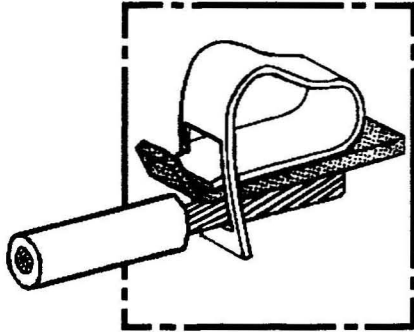

Screwless-type terminal with direct pressure

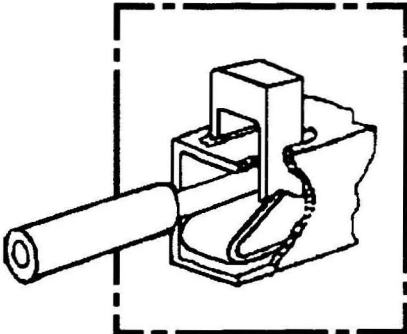

Screwless-type terminal with actuating element

Figure J.2 – Examples of screwless-type terminals

**J.10 Reference documents**

IEC 60228:1978, *Conductors of insulated cables*

IEC 60228A:1982, First supplement to IEC 60228

IEC 60998-1:1990, *Connecting devices for low voltage circuits for household and similar purposes – Part 1: General requirements*

IEC 60998-2-2:1991, *Connecting devices for low-voltage circuits for household and similar purposes – Part 2-2: Particular requirements for connecting devices as separate entities with screwless-type clamping units*

IEC 60999 (all parts), *Connecting devices – Electrical copper conductors – Safety requirements for screw-type and screwless-type clamping units*

ASTM B172-01a, *Standard Specification for Rope-Lay-Stranded Copper Conductors Having Bunch-Stranded Members, for Electrical Conductors*

ICEA S-19-81 / NEMA WC3, *Rubber-Insulated Wire and Cable*<sup>1</sup>

ICEA S-66-524 / NEMA WC7, *Cross-Linked-Thermosetting-Polyethylene Insulated Wire and Cable*<sup>1</sup>

ICEA S-68-516 / NEMA WC8, *Ethylene-Propylene-Rubber Insulated Wire and Cable*<sup>1</sup>

---

<sup>1</sup> Withdrawn

## Annex K (normative)

### Particular requirements for circuit-breakers with flat quick-connect terminations

#### K.1 Scope

This annex applies to circuit-breakers within the scope of clause 1, equipped with flat quick-connect terminations consisting of a male tab (see K.3.2) with nominal width 6,3 mm and thickness 0,8 mm, to be used with a mating female connector for connecting electrical copper conductors according to the manufacturer's instructions, for rated currents up to and including 16 A.

NOTE The use of circuit-breakers with flat quick-connect terminations for rated currents up to and including 20 A is accepted in BE, FR, IT, ES, PT and US.

The connectable electrical copper conductors are flexible, having a cross-sectional area up to and including 4 mm<sup>2</sup>, or rigid stranded, having a cross-sectional area up to and including 2,5 mm<sup>2</sup> (AWG equal to or greater than 12).

This annex applies exclusively to circuit-breakers having male tabs as an integral part of the device.

#### K.2 Normative references

As a complement to clause 2 the following normative references apply:

IEC 61210:1993, *Connecting devices – Flat quick-connect terminations for electrical copper conductors – Safety requirements*

#### K.3 Definitions

As a complement to clause 3, the following definitions apply:

##### K.3.1

##### **flat quick-connect termination**

electrical connection consisting of a male tab and a female connector which can be pushed into and withdrawn with or without the use of a tool

##### K.3.2

##### **male tab**

portion of a quick-connect termination which receives the female connector

##### K.3.3

##### **female connector**

portion of a quick-connect termination which is pushed onto the male tab

##### K.3.4

##### **detent**

dimple (depression) or hole in the male tab which engages a raised portion on the female connector to provide a latch for the mating parts.



**K.4 Classification**

Clause 4 applies.

**K.5 Characteristics of circuit-breakers**

Clause 5 applies.

**K.6 Marking**

The whole of clause 6 applies, with the following addition after the lettered item k).

The following information regarding the female connector according to IEC 61210 and the type of conductor to be used shall be given in the manufacturers' instructions:

- l) manufacturer's name or trade mark;
- m) type reference;
- n) information on cross-sections of conductors and colour code of insulated female connectors (see table K.1 below);
- o) the use of only silver or tin-plated copper alloys.

**Table K.1 – Informative table on colour code of female connectors in relationship with the cross section of the conductor**

Cross-section of the conductor mm <sup>2</sup>	Colour code of the female connector
1	Red
1,5	Red or blue
2,5	Blue or yellow
4	Yellow

**K.7 Standard conditions for operation in service**

Clause 7 applies.

**K.8 Constructional requirements**

Clause 8 applies, with the following exceptions:

*Replacement of 8.1.3 by:*

**K.8.1 Clearances and creepage distances (see annex B)**

Subclause 8.1.3 applies, the female connectors being fitted to the male tabs of the circuit-breaker.

*Replacement of 8.1.5 by:*

**K.8.2 Terminals for external conductors**

**K.8.2.1** Male tabs and female connectors shall be of a metal having mechanical strength, electrical conductivity and resistance to corrosion adequate for their intended use.

NOTE Silver or tin plated copper alloys are examples of suitable solutions.

**K.8.2.2** The nominal width of the male tab is 6,3 mm and the thickness 0,8 mm, applicable to rated currents up to and including 16 A.

NOTE 1 The use for rated currents up to and including 20 A is accepted in BE, FR, IT, PT, ES and US.

The dimensions of the male tab shall comply with those specified in table K.3 and in figures K.2, K.3, K.4 and K.5, where the dimensions A, B, C, D, E, F, J, M, N and Q are mandatory.

The dimensions of the female connector which may be fitted-on are given in figure K.6 and in table K.4.

NOTE 2 The shapes of the various parts may deviate from those given in the figures, provided that the specified dimensions are not influenced and the test requirements are complied with, for example: corrugated tabs, folded tabs, etc.

*Compliance is checked by inspection and by measurement.*

**K.8.2.3** Male tabs shall be securely retained.

*Compliance is checked by the mechanical overload test of K.9.1.*

## **K.9 Tests**

Clause 9 applies, with the following modifications :

*Replacement of 9.5 by:*

### **K.9.1 Mechanical overload-force**

*This test is done on 10 terminals of circuit-breakers, mounted as in normal use when wiring takes place.*

*The axial push force, and successively the axial pull force specified in the following table K.2, are gradually applied to the male tab integrated in the circuit-breaker, once only with a suitable test apparatus.*

**Table K.2 – Overload test forces**

Push N	Pull N
96	88

*No damage which could impair further use shall occur to the tab or to the circuit-breaker in which the tab is integrated.*

*Addition to 9.8.3:*

*Fine-wire thermocouples shall be placed in such a way as not to influence the contact or the connection area. An example of placement is shown in figure K.1.*

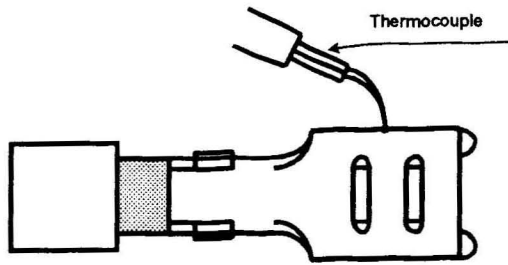

Figure K.1 – Example of position of the thermocouple for measurement of the temperature-rise

Table K.3 – Dimensions of tabs

*Dimensions in millimetres*

Nominal size		A	B min	C	D	E	F	J	M	N	P	Q min
6,3 × 0,8	Dimple	1,0		0,84	6,40	4,1	2,0	12°	2,5	2,0	1,8	
		0,7	7,8	0,77	6,20	3,6	1,6	8°	2,2	1,8	0,7	8,9
	Hole	1,0		0,84	6,40	4,7	2,0	12°			1,8	
		0,5	7,8	0,77	6,20	4,3	1,6	8°			0,7	8,9

NOTE 1 For the dimensions A to Q refer to figures K.2 to K.5.  
 NOTE 2 Where two values are shown in one column, they give the maximum and the minimum dimension.

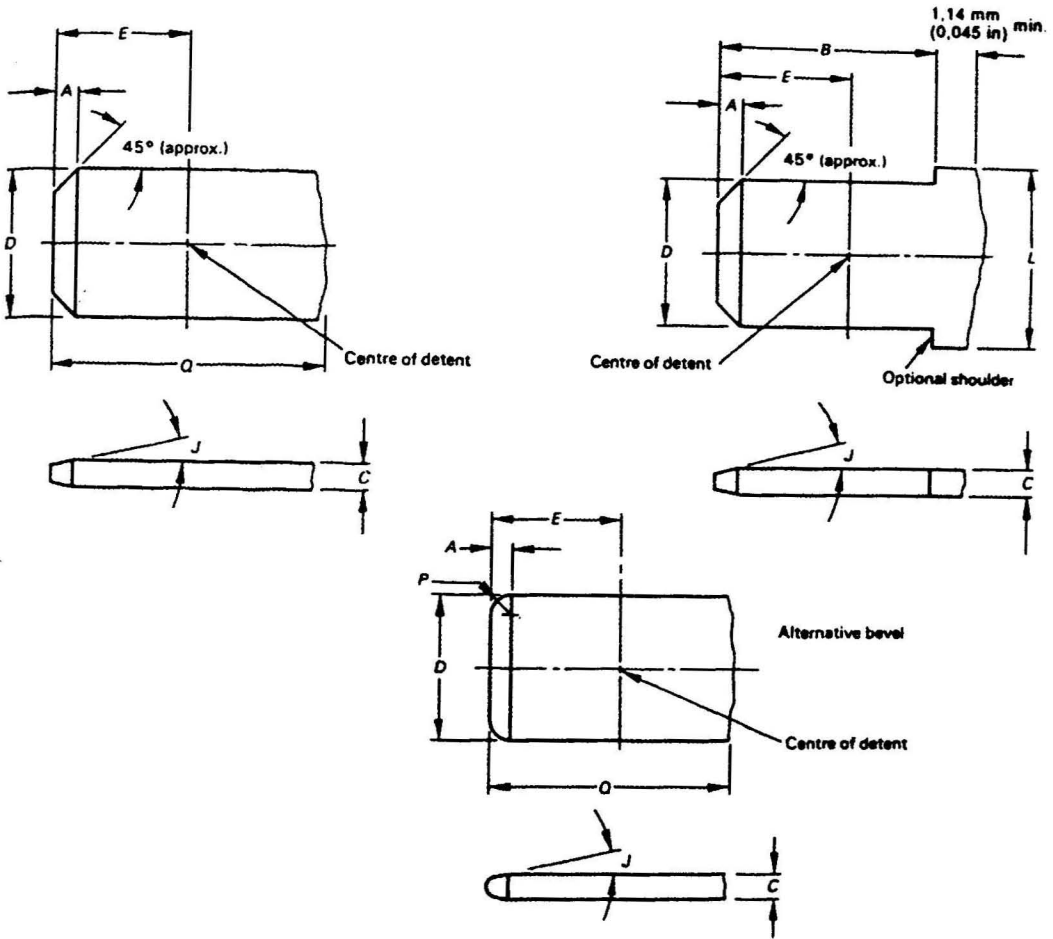

NOTE 1 Bevel A of 45° need not be a straight line if it is within the confines shown.

NOTE 2 Dimension L is not specified and may vary by the application (for example fixing).

NOTE 3 Dimension C of tabs may be produced from more than one layer of material provided that the resulting tab complies in all respects with the requirements of this standard.

A radius on the longitudinal edge of the tab is permissible.

NOTE 4 The sketches are not intended to govern the design except with regard to the dimensions shown.

NOTE 5 The thickness C of the male tab may vary beyond Q or beyond  $B + 1,14 \text{ mm (0,043 in)}$

NOTE 6 All portions of the tabs are flat and free of burrs or raised plateaus, except that there may be a raised plateau over the stock thickness of 0,025 mm (0,001 in) per side, in an area defined by a line surrounding the detent and distant from it by 1,3 mm (0,051 in).

Figure K.2 – Dimensions of male tabs

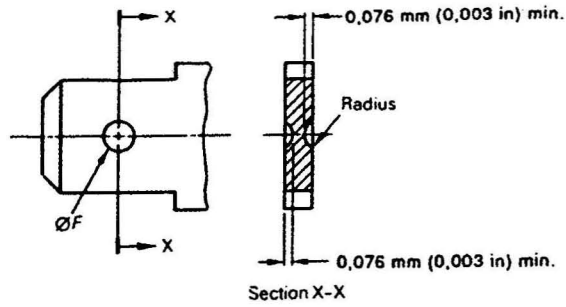

Detent shall be located within 0,076 mm (0,003 in) of the centre-line of the tab.

Figure K.3 – Dimensions of round dimple detents (see figure K.2)

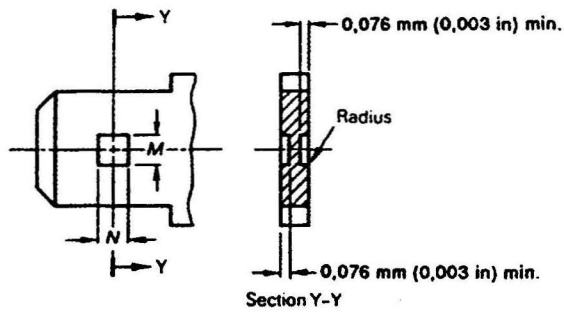

Detent shall be located within 0,13 mm (0,005 in) of the centre-line of the tab.

Figure K.4 – Dimensions of rectangular dimple detents (see figure K.2)

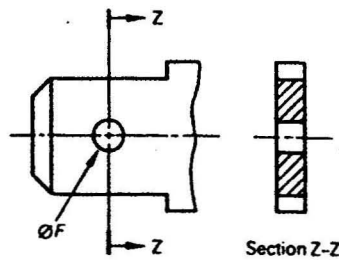

Detent shall be located within 0,076 mm (0,003 in) of the centre-line of the tab.

Figure K.5 – Dimensions of hole detents

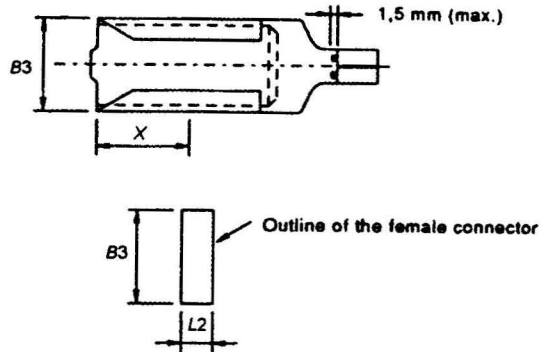

Dimensions  $B3$  and  $L2$  are mandatory.

NOTE 1 For determining female connector dimensions varying from  $B3$  and  $L2$  it is necessary to refer to the tab dimensions in order to ensure that in the most onerous conditions the engagement (and detent, if fitted) between tab and female connector is correct.

NOTE 2 If a detent is provided, the dimension  $X$  is at manufacturer's discretion in order to meet the requirements of the performance clauses.

NOTE 3 Female connectors should be so designed that undue insertion of the conductor into the crimping area is visible or prevented by a stop in order to avoid any interference between the conductor and a fully inserted tab.

NOTE 4 The sketches are not intended to govern the design except as regards the dimensions shown.

Figure K.6 – Dimensions of female connectors

Table K.4 – Dimensions of female connectors

Tab size mm	Dimensions of female connector mm	
	$B3$ max.	$L2$ max.
6,3 × 0,8	7,8	3,5

#### K.10 Reference documents

IEC 60760:1989, *Flat, quick-connect terminations*

**Annex L**  
(normative)

**Specific requirements for circuit-breakers with screw-type terminals  
for external untreated aluminium conductors and with aluminium  
screw-type terminals for use with copper or with aluminium conductors**

**L.1 Scope**

This annex applies to circuit-breakers within the scope of this standard, equipped with screw-type terminals of copper – or of alloys containing at least 58 % of copper (if worked cold) or at least 50 % of copper (if worked otherwise), or of other metal or suitably coated metal, no less resistant to corrosion than copper and having mechanical properties no less suitable – for use with untreated aluminium conductors, or with screw-type terminals of aluminium material for use with copper or aluminium conductors.

In this annex copper-clad and nickel-clad aluminium conductors are considered as aluminium conductors.

NOTE In Austria, Australia and Germany, the use of aluminium screw-type terminals for use with copper conductors is not allowed.

- In Austria, Switzerland and Germany, terminals for aluminium conductors only are not allowed.
- In Spain, the use of aluminium conductors is not allowed for final circuits in household and similar installations e.g. offices, shops..
- In Denmark, the minimum cross-sectional area for aluminium conductors is 16 mm<sup>2</sup>.

**L.2 Normative references**

Void.

**L.3 Definitions**

As a complement to clause 3, the following additional definitions apply for the purpose of this annex.

**L.2.1**

**treated conductor**

contact area of a conductor that has had its oxide layer on the outside strands scraped away and/or has had a compound added to improve connectability and/or prevent corrosion

**L.2.2****untreated/unprepared conductor**

conductor which has been cut and the insulation of which has been removed for insertion into a terminal

NOTE A conductor, the shape of which is arranged for introduction into a terminal or the strands of which are twisted to consolidate the end, is considered to be an unprepared conductor.

**L.2.3****equalizer**

arrangement used in the test loop to ensure an equipotentiality point and uniform current density in a stranded conductor, without adversely affecting the temperature of the conductor(s)

**L.2.4****reference conductor**

continuous length of the same type and size conductor as that used in the terminal unit under test and connected in the same series circuit. It enables the reference temperature and, if required, reference resistance to be determined

**L.2.5****stability factor  $S_f$** 

measure of temperature stability of a terminal unit during the current cycling test

**L.4 Classification**

Clause 4 applies.

**L.5 Characteristics of circuit-breakers**

Clause 5 applies.

**L.6 Marking**

In addition to clause 6 the following requirements apply:

The terminal marking defined in table L.1 shall be marked on the circuit-breaker, near the terminals.

The other information concerning the number of conductors, the screw torque values (if different from table 10) and the cross-sections, shall be indicated on the circuit-breaker.

**Table L.1 – Marking for terminals**

Conductor types accepted	Marking
Copper only	None
Aluminium only	Al
Aluminium and copper	Al/Cu

The manufacturer shall state in his catalogue that, for the clamping of an aluminium conductor the tightening torque shall be applied with appropriate means.



**L.7 Standard conditions for operation in service**

Clause 7 applies.

**L.8 Constructional requirements**

Clause 8 applies, with the following exceptions:

**8.1.5.2 is completed by:**

For the connection of aluminium conductors, circuit-breakers shall be provided with screw-type terminals allowing the connection of conductors having nominal cross-sections as shown in table L.2.

Terminals for the connection of aluminium conductors and terminals of aluminium for the connection of copper or aluminium conductors shall have mechanical strength adequate to withstand the tests of 9.4, with the test conductors tightened with the torque indicated in table 10, or with the torque specified by the manufacturer, which shall never be lower than that specified in table 10.

**Table L.2 – Connectable cross-sections of aluminium conductors for screw-type terminals**

Rated Current <sup>a</sup> A	Range of nominal cross-sections <sup>b</sup> to be clamped mm <sup>2</sup>
Up to and including 13	1 to 4
Above 13 up to and including 16	1 to 6
Above 16 up to and including 25	1,5 to 10
Above 25 up to and including 32	2,5 to 16
Above 32 up to and including 50	4 to 25
Above 50 up to and including 80	10 to 35
Above 80 up to and including 100	16 to 50
Above 100 up to and including 125	25 to 70

<sup>a</sup> It is required that, for current ratings up to and including 50 A, terminals be designed to clamp solid conductors as well as rigid stranded conductors; the use of flexible conductors is permitted. Nevertheless, it is permitted that terminals for conductors having cross-sections from 1 mm<sup>2</sup> up to 10 mm<sup>2</sup> be designed to clamp solid conductors only.

<sup>b</sup> Maximum wire sizes of table 5, increased according to table D.2 of IEC 61545.

*Compliance is checked by inspection, by measurement and by fitting in turn one conductor of the smallest and one of the largest cross-section areas as specified.*

**8.1.5.4 The text of 8.1.5.4 is replaced by:**

Terminals shall allow the conductors to be connected without special preparation.

*Compliance is checked by inspection and the tests of L.9.*

## L.9 Tests

Clause 9 applies, with the following modifications/additions:

*For the tests which are influenced by the material of the terminal and the type of conductor that can be connected, the test conditions of table L.3 are applied.*

*Additionally the test of L.9.2 is carried out on terminals separated from the circuit-breaker.*

**Table L.3 – List of tests according to the material of conductors and terminals**

Material of terminals	Material according to 8.1.4.4 <sup>a</sup>	Al <sup>a</sup>	
		Cu	Al
Material of conductor (table L.1)	Al Use tables L.2 and L.5	Cu Use tables 5 and 9	Al Use tables L.2 and L.5
9.4 Reliability of screws	Use tables L.2, L.5 and 10	Use tables 5, 9 and 10	Use tables L.2, L.5 and 10
9.5.1 Pull-out test <sup>b</sup>	Use tables L.2, L.5 and 10	Use tables 5, 9 and 10	Use tables L.2, L.5 and 10
9.5.2 Damage of the conductor	Use tables L.2, L.5 and 10	Use tables 5, 9 and 10	Use tables L.2, L.5 and 10
9.5.3 Insertion of the conductor	Use table L.4	Use table 12	Use table L.4
9.8 Temperature rise	Use table L.5	Use table 9	Use table L.5
9.9 28-day test	Use table L.5	Use table 9	Use table L.5
L.9.2 Cycling test	Use table 10	Use table 10	Use table 10
<sup>a</sup> Use test sequences A and B and number of samples defined in Annex C. For circuit-breakers which are able to be connected to Al or Cu conductors, the test sequences and number of samples have to be doubled (one for the Cu conductor and one for the Al conductor)			
<sup>b</sup> For the pull-out test 9.5.1, the value for 70 mm <sup>2</sup> wire is under consideration.			

Table L.4 – Connectable conductors and their theoretical diameters

Metric					AWG				
Rigid			Flexible (copper only)		Rigid			Flexible (copper only)	
S	Solid	Stranded	S			Solid <sup>a</sup>	Class B stranded <sup>a</sup>		Classes <sup>b</sup> I, K, M stranded
mm <sup>2</sup>	∅ mm	∅ mm	mm <sup>2</sup>	∅ mm	Gauge	∅ mm	∅ mm	Gauge	mm
1,0	1,2	1,4	1,0	1,5	18	1,07	1,23	18	1,28
1,5	1,5	1,7	1,5	1,8	16	1,35	1,55	16	1,50
2,5	1,9	2,2	2,5	2,3 <sup>c</sup>	14	1,71	1,95	14	2,08
4,0	2,4	2,7	4,0	2,9 <sup>c</sup>	12	2,15	2,45	12	2,70
6,0	2,9	3,3	4,0	2,9 <sup>c</sup>	10	2,72	3,09		
10,0	3,7	4,2	6,0	3,9	8	3,43	3,89	10	3,36
16,0	4,6	5,3	10,0	5,1	6	4,32	4,91	8	4,32
25,0		6,6	16,0	6,3	4	5,45	6,18	6	5,73
35,0		7,9	25,0	7,8	2	6,87	7,78	4	7,25
					1	7,72	8,85		
50,0		9,1	35	9,2	0	8,51	9,64		12,08
70,0		12,0	50	12	00	9,266	10,64		

NOTE Diameters of the largest rigid and flexible conductors are based on IEC 60228A, table 1 and, for AWG conductors, on ASTM B 172-71, ICEA S-19-81, ICEA S-66-524, ICEA S-68-516.

<sup>a</sup> Nominal diameter + 5 %.

<sup>b</sup> Largest diameter + 5 % for any of the three classes I, K, M.

<sup>c</sup> Dimensions for class 5 flexible conductors only, according to IEC 60228A.

L.9.1 Test conditions

Subclause 9.1 applies, except that the Al conductors to be connected are taken from table L.5.

Table L.5 – Cross sections (S) of aluminium test conductors corresponding to the rated currents

S mm <sup>2</sup>	I <sub>n</sub> A
1,5	I <sub>n</sub> ≤ 6
2,5	6 < I <sub>n</sub> ≤ 13
4	13 < I <sub>n</sub> ≤ 20
6	20 < I <sub>n</sub> ≤ 25
10	25 < I <sub>n</sub> ≤ 32
16	32 < I <sub>n</sub> ≤ 50
25	50 < I <sub>n</sub> ≤ 63
35	63 < I <sub>n</sub> ≤ 80
50	80 < I <sub>n</sub> ≤ 100
70	100 < I <sub>n</sub> ≤ 125

**L.9.2 Current cycling test**

*This test verifies the stability of the screw-type terminal by comparing the temperature performance with that of the reference conductor under accelerated cycling conditions.*

*This test is carried out on separate terminals.*

**L.9.2.1 Preparation**

*The test is performed on four specimens, each one made by a couple of terminals, assembled in a manner which represents the use of the terminals in the circuit-breaker (see examples shown in figures L.2 to L.6). The screw-type terminals which have been removed from the product shall be attached to the conducting parts of the same cross-section, shape, metal and finish as that on which they are mounted on the product. The screw-type terminals shall be fixed to the conducting parts in the same manner (position, torque, etc.) as on the product. If one specimen fails during the test, four other specimens shall be tested and no other failures are admitted.*

**L.9.2.2 Test arrangement**

*The general arrangement of the samples shall be as shown in figure L.1.*

*Ninety per cent of the value of torque stated by the manufacturer or, if not stated, selected in table 10 shall be used for the test specimens.*

*The test is carried out with conductors according to table L.5. The length of the test conductor from the point of entry to the screw-type terminal specimens to the equalizer (see L.3.3) shall be as in table L.6.*

**Table L.6 – Test conductor length**

<b>Conductor cross section</b> <i>mm<sup>2</sup></i>	<b>Conductor wire size</b> <i>AWG</i>	<b>Minimum conductor length</b> <i>mm</i>
$S \leq 10,0$	$\leq 8$	200
$16,0 \leq S \leq 25,0$	6 to 3	300
$35,0 \leq S \leq 70,0$	2 to 00	460

*Test conductors are connected in series with a reference conductor of the same cross-section.*

*The length of the reference conductor shall be approximately at least twice the length of the test conductor.*

*Each free end of the test and reference conductor(s) not connected to a screw-type terminal specimen shall be welded or brazed to a short length of an equalizer of the same material as the conductor and of cross section not greater than that given in table L.7. All strands of the conductor shall be welded or brazed to make an electrical connection with the equalizer.*

*Tool-applied compression type terminations without welding may be used for the equalizer if acceptable to the manufacturer and if the same performance is provided.*

Table L.7 – Equalizer and busbar dimensions

Range of test current A	Maximum cross section mm <sup>2</sup>	
	Al	Cu
0 - 50	45	45
51 - 125	105	85
126 - 225	185	155

The separation between the test and reference conductors shall be at least 150 mm.

The test specimen shall be suspended either horizontally or vertically in free air by supporting the equalizer or busbar by non-conductive supports so as not to subject the screw-type terminal to a tensile load. Thermal barriers shall be installed midway between the conductors which shall extend 25 mm ± 5 mm widthways and 150 mm ± 10 mm lengthways beyond the screw-type terminals (see figure L.1). Thermal barriers are not required provided the specimens are separated by at least 450 mm. The specimens shall be located at least 600 mm from the floor, wall or ceiling.

The test specimens shall be located in a substantially vibration-free and draught-free environment and at an ambient temperature between 20 °C and 25 °C. Once the test is started, the maximum permissible variation is ±1 K provided the range limitation is not exceeded.

#### L.9.2.3 Temperature measurement

Temperature measurements are made by means of thermocouples, using a wire having a cross-section of not more than 0,07 mm<sup>2</sup> (approximately 30 AWG).

For screw-type terminals, the thermocouple shall be located on the conductor entry side of the screw-type terminal, close to the contact interface.

For the reference conductor, the thermocouples shall be located midway between the ends of the conductor, and under its insulation.

Positioning of the thermocouples shall not damage the screw-type terminal or the reference conductor.

NOTE 1 Drilling of a small hole and subsequent fastening of the thermocouple is an acceptable method, provided that the performance is not affected and that it is agreed by the manufacturer.

The ambient temperature shall be measured with two thermocouples in such a manner as to achieve an average and stable reading in the vicinity of the test loop without undue external influence. The thermocouples shall be located in a horizontal plane intersecting the specimens, at a minimum distance of 600 mm from them.

NOTE 2 A satisfactory method for achieving a stable measurement is, for example, to attach the thermocouple to unplated copper plates approximately 50 mm × 50 mm, having a thickness between 6 mm and 10 mm.

#### L.9.2.4 Test method and acceptance criteria

NOTE 1 Evaluation of performance is based on both the limit of screw-type terminal temperature rise and the temperature variation during the test.

*The test loop shall be subjected to 500 cycles of 1 h current-on and 1 h current-off, starting at an a.c. current equal to 1,12 times the test current value determined in table L.8. Near the end of each current-on period of the first 24 cycles, the current shall subsequently be adjusted to raise the temperature of the reference conductor to 75°C.*

*At the 25th cycle the test current shall be adjusted for the last time and the stable temperature shall be recorded as the first measurement. There shall be no further adjustment of the test current for the remainder of the test.*

*Temperatures shall be recorded for at least one cycle of each working day, and after approximately 25, 50, 75, 100, 125, 175, 225, 275, 350, 425, and 500 cycles.*

*The temperature shall be measured during the last 5 min of the current-on time. If the size of the set of test specimens or the speed of the data acquisition system is such that not all measurements can be completed within 5 min, the current-on time shall be extended as necessary to complete such measurements.*

*After the first 25 cycles the current-off time may be reduced to a time 5 min longer than the time necessary to all terminal assemblies for cooling down to a temperature between ambient temperature  $T_a$  and  $T_a + 5$  K during the current-off period. Forced-air cooling may be employed to reduce the off time, if acceptable to the manufacturer. In that case it shall be applied to the entire test loop and the resulting temperature of the forced air shall not be lower than the ambient air temperature.*

*The stability factor  $S_f$  for each of the 11 temperature measurements is to be determined by subtracting the average temperature deviation  $D$  from the 11 values of the temperature deviation  $d$ .*

*The temperature deviation  $d$  for the 11 individual temperature measurements is obtained by subtracting the associated reference conductor temperature from the screw-type terminal temperature.*

NOTE 2 The value of  $d$  is positive if the screw-type temperature is higher than that of the reference conductor and negative if it is lower.

*For each screw-type terminal*

- *the temperature rise shall not exceed 110 K;*
- *the stability factor  $S_f$  shall not exceed  $\pm 10$  °C.*

*An example of calculation for one screw-type terminal is given in table L.9.*

Table L.8 – Test current as a function of rated current

Metric sizes		
Rated current	Al conductor size	Test current
A	mm <sup>2</sup>	A
$0 \leq I_n \leq 15$	2,5	26
$15 < I_n \leq 20$	4	35
$20 < I_n \leq 25$	6	46
$25 < I_n \leq 32$	10	60
$32 < I_n \leq 50$	16	79
$50 < I_n \leq 65$	25	99
$65 < I_n \leq 80$	35	137
$80 < I_n \leq 100$	50	171
$100 < I_n \leq 125$	70	190

AWG		
Rated current	Al conductor size	Test Current
A	N°	A
$0 < I_n \leq 15$	12	30
$15 < I_n \leq 25$	10	40
$25 < I_n \leq 40$	8	53
$40 < I_n \leq 50$	6	69
$50 < I_n \leq 65$	4	99
$65 < I_n \leq 75$	3	110
$75 < I_n \leq 90$	2	123
$90 < I_n \leq 100$	1	152
$100 < I_n \leq 120$	0	190

Table L.9 – Example of calculation for determining the average temperature deviation *D*

Temperature measurement	Cycle Number	Temperatures		Temperature deviation <i>d = a - b</i>	Stability factor <i>Sf = d - D</i>
		Screw-type terminal <i>a</i>	Reference conductor <i>b</i>		
		°C	°C	K	K
1	25	79	78	1	0,18
2	50	80	77	3	2,18
3	75	78	78	0	-0,82
4	100	76	77	-1	-1,82
5	125	77	77	0	-0,82
6	175	78	77	1	0,18
7	225	79	76	3	2,18
8	275	78	76	2	1,18
9	350	77	78	-1	-1,82
10	425	77	79	-2	-2,82
11	500	81	78	3	2,18

$$\text{Average temperature deviation } D = \frac{\Sigma d}{\text{number of measurements}} = \frac{9}{11} = 0,82$$

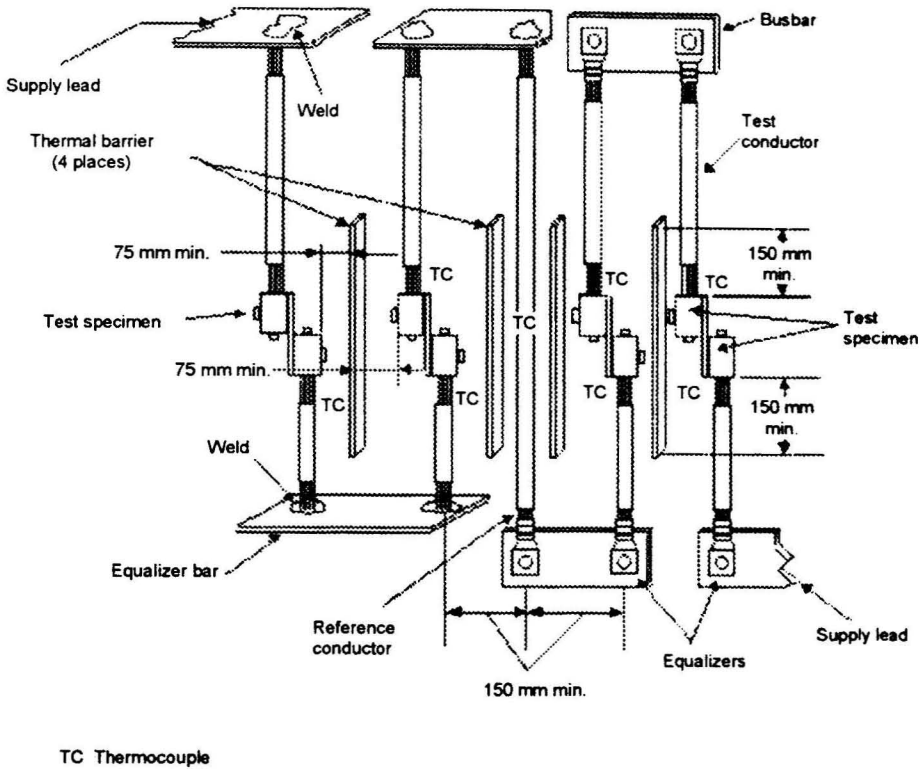
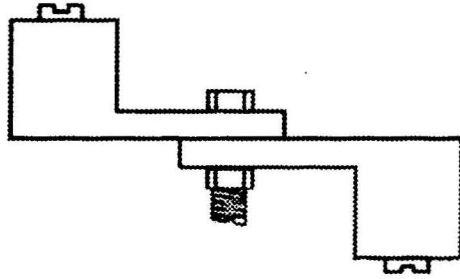

Figure L.1 – General arrangement for the test





NOTE The conducting part may be bolted, soldered or welded.

Figure L.2

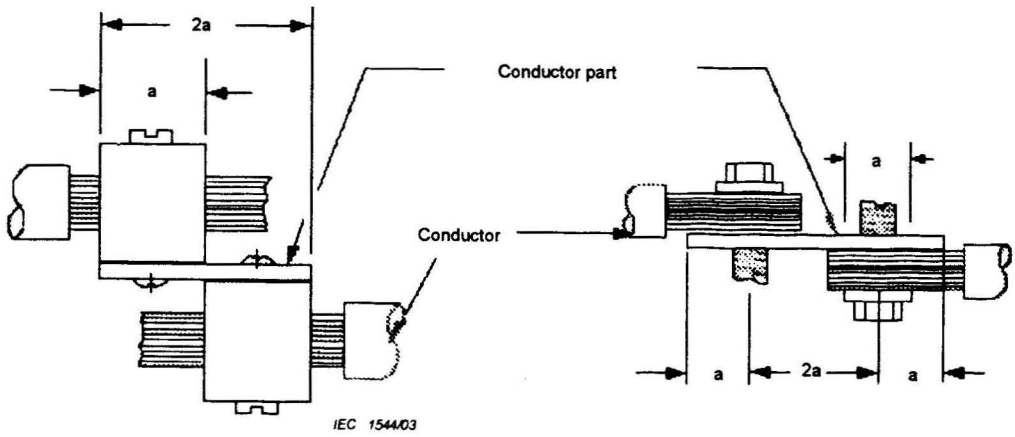

Figure L.3

Figure L.4

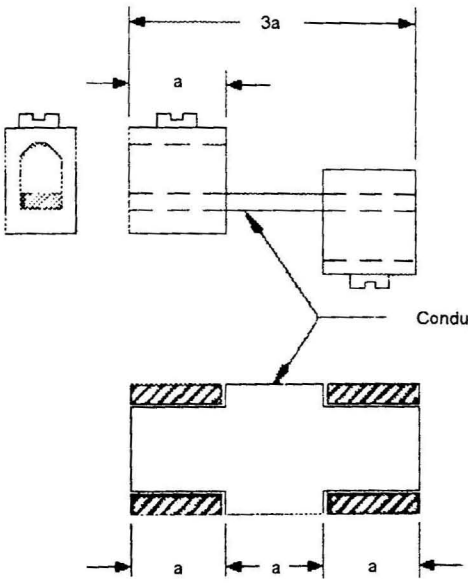

Figure L.5

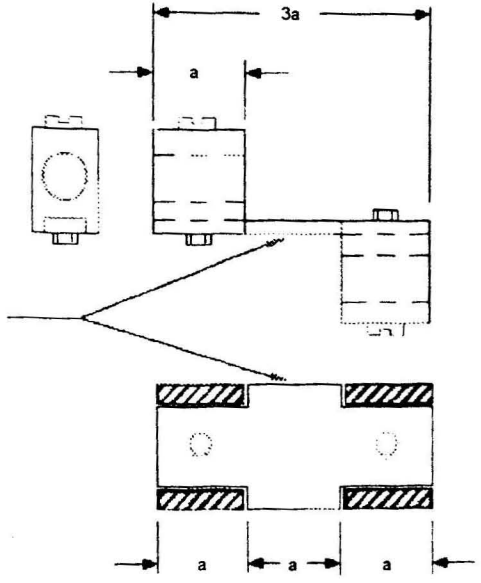

Figure L.6

**Bibliography**

IEC 60898-2:1996, *Circuit-breakers for overcurrent protection for household and similar installations – Part 2: Circuit-breakers for a.c. and d.c. operation*

IEC 61009-1:1996, *Residual current operated circuit-breakers with integral overcurrent protection for household and similar uses (RCBO's) – Part 1: General rules*

IEC 61009-2-1:1991, *Residual current operated circuit-breakers with integral overcurrent protection for household and similar use (RCBO's) – Part 2-1: Applicability of the general rules to RCBO's functionally independent of line voltage*

IEC 61009-2-2:1991, *Residual current operated circuit-breakers with integral overcurrent protection for household and similar uses (RCBO's) – Part 2-2: Applicability of the general rules to RCBO's functionally dependent on line voltage*

ISO 2039-2:1987, *Plastics – Determination of hardness – Part 2: Rockwell hardness*

---

## Bureau of Indian Standards

BIS is a statutory institution established under the *Bureau of Indian Standards Act, 1986* to promote harmonious development of the activities of standardization, marking and quality certification of goods and attending to connected matters in the country.

### Copyright

BIS has the copyright of all its publications. No part of these publications may be reproduced in any form without the prior permission in writing of BIS. This does not preclude the free use, in the course of implementing the standard, of necessary details, such as symbols and sizes, type or grade designations. Enquiries relating to copyright be addressed to the Director (Publications), BIS.

### Review of Indian Standards

Amendments are issued to standards as the need arises on the basis of comments. Standards are also reviewed periodically; a standard along with amendments is reaffirmed when such review indicates that no changes are needed; if the review indicates that changes are needed, it is taken up for revision. Users of Indian Standards should ascertain that they are in possession of the latest amendments or edition by referring to the latest issue of 'BIS Catalogue' and 'Standards: Monthly Additions'.

This Indian Standard has been developed from Doc: No. ETD 07 (5582).

### Amendments Issued Since Publication

Amend No.	Date of Issue	Text Affected

## BUREAU OF INDIAN STANDARDS

### Headquarters:

Manak Bhavan, 9 Bahadur Shah Zafar Marg, New Delhi 110002

Telephones: 2323 0131, 2323 3375, 2323 9402

website : [www.bis.org.in](http://www.bis.org.in)

### Regional Offices:

	Telephones
Central : Manak Bhavan, 9 Bahadur Shah Zafar Marg NEW DELHI 110002	{ 2323 7617 2323 3841
Eastern : 1/14 C.I.T. Scheme VII M, V.I.P. Road, Kankurgachi KOLKATA 700054	{ 2337 8499, 2337 8561 2337 8626, 2337 9120
Northern : SCO 335-336, Sector 34-A, CHANDIGARH 160022	{ 260 3843 260 9285
Southern : C.I.T. Campus, IV Cross Road, CHENNAI 600113	{ 2254 1216, 2254 1442 2254 2519, 2254 2315
Western : Manakalaya, E9 MIDC, Marol, Andheri (East) MUMBAI 400093	{ 2832 9295, 2832 7858 2832 7891, 2832 7892

**Branches:** AHMEDABAD. BANGALORE. BHOPAL. BHUBANESHWAR. COIMBATORE. FARIDABAD. GHAZIABAD. GUWAHATI. HYDERABAD. JAIPUR. KANPUR. LUCKNOW. NAGPUR. PARWANOO. PATNA. PUNE. RAJKOT. THIRUVANANTHAPURAM. VISAKHAPATNAM.