

इंटरनेट

मानक

Disclosure to Promote the Right To Information

Whereas the Parliament of India has set out to provide a practical regime of right to information for citizens to secure access to information under the control of public authorities, in order to promote transparency and accountability in the working of every public authority, and whereas the attached publication of the Bureau of Indian Standards is of particular interest to the public, particularly disadvantaged communities and those engaged in the pursuit of education and knowledge, the attached public safety standard is made available to promote the timely dissemination of this information in an accurate manner to the public.

“जानने का अधिकार, जीने का अधिकार”

Mazdoor Kisan Shakti Sangathan

“The Right to Information, The Right to Live”

“पुराने को छोड़ नये के तरफ”

Jawaharlal Nehru

“Step Out From the Old to the New”

IS 6533-2 (1989): Code of practice for design and construction of steel chimneys, Part 2: Structural aspects [CED 7: Structural Engineering and structural sections]



“ज्ञान से एक नये भारत का निर्माण”

Satyanarayan Gangaram Pitroda

“Invent a New India Using Knowledge”



“ज्ञान एक ऐसा खजाना है जो कभी चुराया नहीं जा सकता है”

Bhartrhari—Nitiśatakam

“Knowledge is such a treasure which cannot be stolen”

BLANK PAGE



भारतीय मानक
इस्पात की चिमनी के डिजाइन और निर्माण रीति संहिता
भाग 2 संरचना पक्ष
(पहला पुनरीक्षण)

Indian Standard

CODE OF PRACTICE FOR DESIGN AND
CONSTRUCTION OF STEEL CHIMNEY

PART 2 STRUCTURAL ASPECT

(First Revision)

Third Reprint MARCH 1998

UDC 697·8 (669·14) : 69·001·3

© BIS 1991

BUREAU OF INDIAN STANDARDS
MANAK BHAVAN, 9 BAHADUR SHAH ZAFAR MARG
NEW DELHI 110002

FOREWORD

This Indian Standard (Part 2) (First Revision) was adopted by the Bureau of Indian Standards on 20 April 1989, after the draft finalized by the Structural Engineering Sectional Committee had been approved by the Civil Engineering Division Council.

This standard was first published in 1971. On suggestions by practising engineers and representatives of various organizations in the country, the Sectional Committee decided to bifurcate the standard in two parts, separating structural aspects from the mechanical aspects as follows:

Part 1 Mechanical aspects, and

Part 2 Structural aspects.

In this part (Part 2), the dynamic effects of wind have been included as a check for resonance oscillations. More accurate method of determining the natural frequency of oscillation has been included. Many of the commonly known formulae and calculation steps for design have been deleted to make the code concise. Further, since the principal load on the chimney is wind load, no increase in permissible stress is envisaged in this code aligning with the present line of thinking for wind loads.

Atmospheric pollution regulations necessitate adoption of tall chimneys which require strengthening against stresses caused by oscillation due to wind action. Alternative procedures (a) making an appropriate increase in the design wind loading, and (b) indicating the need of strengthening or incorporation of devices for suppressing von-Karman type oscillations are given in Annex A.

Certain methods of strengthening, such as welding or bolting helical strakes to the top one-third height of the chimney and the installation of damping devices are recommended (see A-2.2).

Design and construction of chimneys have become specialized field with a lot of scope for research and modifications. It is, therefore, attempted in this standard to cover only the basic requirements. The designer should use his discretion in the use of research data available.

In the preparation of this standard, considerable assistance has been derived from the following:

- a) BS 4076 : 1978 Specification for steel chimneys, and
- b) Stroitelny Normi E Provila (SNIP-II-VI-1974) USSR (Soviet Norms on Loads and Actions).

Indian Standard

CODE OF PRACTICE FOR DESIGN AND CONSTRUCTION OF STEEL CHIMNEY

PART 2 STRUCTURAL ASPECT

(First Revision)

1 SCOPE

1.1 This standard (Part 2) covers terminology, loading, materials, structural design, construction, inspection, maintenance and painting of both self-supporting and guyed steel chimneys (with or without lining) and their supporting structures.

1.2 The design of chimneys of cross section other than circular is not included in this standard.

1.3 Chimneys in pairs, rows or groups, and those near other structures of comparable height may be subjected to exceptional wind force and particularly wind induced oscillations greater than that allowed for in this standard. Appropriate expert advice should, therefore, be obtained in these cases.

1.4 The purpose for which the chimney is required will determine whether lining, insulation or cladding is necessary.

2 REFERENCES

2.1 The Indian Standards listed in Annex B are necessary adjuncts to this standard.

3 STATUTORY PROVISIONS

3.1 Compliance with this code does not relieve any one from the responsibility of observing provisions as may have been promulgated by any statutory body and/or observing provincial building byelaws and the civil aviation requirements pertaining to such structures.

4 TERMINOLOGY

4.0 For the purpose of this standard, definitions given in **4.1** to **4.40** shall apply.

4.1 Access Door

A door for the entry of personnel.

4.2 Access Hooks

Fittings welded to a chimney to permit the attachment of steeplejack's equipment.

4.3 Access Ladder

A steel ladder provided along the height of the chimney fixed with chimney shell for providing access for personnel to reach different heights for inspection/maintenance, etc.

4.4 Aerodynamic Stabilizer

A device fitted to the structural shell to reduce wind excited oscillations by modifying vertex sheddings.

4.5 Anchor for Guy

The foundation for the fixing of guy.

4.6 Base Gussets

A triangular or trapezoidal steel plate fixed to the chimney shell and to the base plate.

4.7 Base Plate

A horizontal steel plate fixed to the base of a chimney.

4.8 Base Stool

A construction comprising two vertical plates (base gussets) welded to the chimney shell and to the base plate, supporting a horizontal plate through which the holding down bolts pass and against which the bolts can be tightened.

4.9 Bracket

A construction providing resistance to lateral displacement of the chimney, and/or supporting part or all of the weight of the chimney.

4.10 Bracketed Chimney

A chimney in which not all external applied loads (namely, wind) are carried exclusively by the structural shell and for which brackets are provided to ensure stability.

4.11 Clean Out Door

A door, normally at the base of the chimney, to permit the removal of flue dust and/or provide access.

4.12 Cope Band

A steel flat or angle attached to the top of the chimney around its perimeter to give added strength and corrosion resistance at this level.

4.13 Cope-Hood

A hood fitted externally to the top of a liner, covering the upstand of the cap plate to prevent the ingress of rain water.

4.14 Corrosion Test Piece

A fixed or removable steel plate insert, generally of lesser thickness than the shell of the chimney, in contact with the waste gases and fitted at strategic points where maximum corrosion is expected to occur.

4.15 Cowl

A conical or dished cap fitted to the top of the chimney to prevent or minimize entry of rain water.

4.16 Cowl Stays

Steel stays which connect the cowl to the top of the chimney.

4.17 Cravat

An upstand fixed to the roof of a building or roof plate to prevent the entry of rain water into the building.

4.18 Double Skin Chimney

A chimney consisting of an outer load-bearing steel shell and all inner steel liner which carries the flue gases.

4.19 Doubling Plate

A plate fixed to the shell to reinforce it where increased stresses occur.

4.20 Flare

The bottom portion of the chimney in the form of a truncated cone.

4.21 Gallery

The platform around the shaft for observation and maintenance.

4.22 Guy

A wire rope attached at one end of the chimney and anchored at the other end so as to provide resistance to the lateral displacement of the top of the chimney.

4.23 Guy Band

A steel band/section fitted around the outside of a chimney with provision for the attachment of guys.

4.24 Guyed Chimney

A chimney in which not all externally applied loads (namely, wind) are carried exclusively by the structural shell and for which guys are provided to ensure stability.

4.25 Height of Steel Shaft

Length between underside of base plate and the top of the chimney.

4.26 Holding Down Bolts

Bolts built into a concrete foundation or supporting framework to provide anchorage at the base of the chimney.

4.27 Inlet

An opening in the side of a chimney to permit the entry of exhaust gases from connecting flue duct.

4.28 Joint Flange

A steel section fitted to the end of a chimney section to enable section to be connected together.

4.29 Lateral Supports

Supports positioned at appropriate levels within the structural shell to locate the liners and to allow for their independent expansion.

4.30 Liners

Flue ducts contained within a structural shell.

4.31 Multiflue Chimney

A group of two or more chimneys within a structural framework or a group of two or more liners within a structural shell.

4.32 Nominal Chimney Diameter

Internal diameter at the top of the steel shell.

4.33 Roof Plate

A plate which follows the contour of the roof round the chimneys where it passes through the roof. It is also known as flashing around the chimney.

4.34 Self-Supporting Chimney

A chimney in which externally applied loads (namely, wind) are carried exclusively by the structural shell and which together with the foundation, will remain stable under all design conditions without additional support.

4.35 Stack

Normally the straight portion of the chimney.

4.36 Stay

A rigid member providing both tensile and compressive resistance to the lateral displacement of the chimney.

4.37 Stayed Chimney

A chimney in which not all externally applied loads (namely, wind) are carried exclusively by the structural shell and for which stays are provided to ensure stability.

4.38 Strake Vane

An aerodynamic stabilizer fitted to reduce wind excited oscillations.

4.39 Structural Shell

The main external steel plate of the chimney excluding any flanges.

4.40 Weather Hood

A hood designed to shed rain water clear of the cravat and prevent its entry into the building.

5 MATERIALS

5.1 Plates and Sections

Steel plates and sections used in the constructions of chimneys shall conform to IS 226 : 1975, IS 961 : 1975, IS 2062 : 1984 or IS 8500 : 1977, whichever is appropriate. Suitable stainless or alloy steels may be used in special circumstances, such as, when the gases are of an extremely aggressive nature or are at a temperature higher than 480°C but the thickness shall otherwise comply with the requirements of this specification.

5.2 Rivets

Rivets used in the constructions of chimneys shall comply with IS 1929 : 1982 and IS 2155 : 1982, as appropriate. Rivets made of high tensile steel, if used, shall conform to IS 1149 : 1982.

5.3 Welding Consumables

5.3.1 Covered electrodes shall conform to IS 814 (Part 1) : 1974, IS 814 (Part 2) : 1974 or IS 1395 : 1982, as appropriate.

5.3.2 The bare wire electrodes for submerged arc welding shall conform to IS 7280 : 1974. The combination of wire and flux shall satisfy the requirements of IS 3613 : 1974.

5.3.3 Filler rods and bare electrodes for gas sheilded metal arc welding shall conform to IS 6419 : 1971 and IS 6500 : 1972, as appropriate.

5.4 Bolts and Nuts

Bolts and nuts shall conform to IS 1363 : 1984, 1364 : 1983, IS 3640 : 1982, IS 3757 : 1972, IS 6623 : 1972, IS 6639 : 1972, and IS 7002 : 1972 as appropriate. Foundation bolts shall conform to IS 5624 : 1970.

5.4.1 Supply conditions of threaded fasteners shall conform to IS 1367 (Part 1) : 1980, IS 1367 (Part 3) : 1979 and IS 1367 (Part 6) : 1980, as appropriate.

5.5 Washers

Washers shall conform to IS 5369 : 1975, IS 5370 : 1969, IS 6610 : 1972 and IS 6649 : 1972, as appropriate.

5.6 Steel Castings

Steel castings shall conform to Grade 23-45 of IS 1030 : 1982.

5.7 Guy Ropes and Fittings

Guy ropes shall conform to IS 2141 : 1979 and IS 2266 : 1970 and shall be galvanized or protected from corrosion by other suitable means.

5.8 Other materials used in association with steel works shall, where appropriate Indian Standard Specification for the material exist, conform to such specification.

6 LOADING AND LOAD COMBINATIONS

6.1 Dead Loads

Where the unit weight of materials are not known, the dead load shall be calculated according to IS 875 (Part 1) : 1987.

6.1.1 In calculating dead loads, the weight of chimney shell, permanent fixtures such as, ladders, platforms, baffles, and guys (if any) shall be included. The weight of flue lining shall be treated as a separate load for the purpose of load combinations. The flue lining shall not be assumed to increase section modulus of the shell nor resist overturning due to its lateral bending stiffness or strutting action.

6.2 Imposed Loads

Imposed loads on platforms shall be taken at the rate of 300 kg/m².

6.3 Wind Loads

The wind loads shall be calculated in accordance with the provisions contained in IS 875 (Part 3) : 1987.

6.3.1 Wind force on ladders and other fixtures fixed to a chimney shall be determined and added to the force on the chimney.

6.4 Earthquake Loads

Unless otherwise specified, the provision contained in IS 1893 : 1975 shall apply.

6.5 Load Combination

For the design of chimney and its foundation, any of the following load combinations which produce maximum forces and effects and consequently maximum stresses shall be chosen:

- a) Dead load + wind load,
- b) Dead load + earthquake load,
- c) Dead load + load due to lining + imposed load on service platforms + wind load, or
- d) Dead load + load due to lining + imposed load on service platforms + earthquake loads.

7 DESIGN

7.1 General

For the design of chimney shell and other components of chimney in steel, the relevant provisions contained in IS 800 : 1984 shall be applicable in conjunction with the provision of this standard.

7.1.1 The provisions covered in IS 800 : 1984 regarding the following shall, however, be superseded by the requirements of this standard:

- a) Minimum thickness,
- b) Allowable deflection,
- c) Allowance for corrosion,
- d) Allowance for temperature,
- e) Allowable compressive stress in circular shells due to direct force and bending moment, and
- f) Stresses due to earthquake.

7.2 Basic Dimensions

7.2.1 The basic dimensions of the chimney, namely, clear diameter, height, etc, are decided on considerations of temperature, composition of flue gases, adjacent structures, pollution control, draft requirements, etc, with Part 1 in accordance with this standard. Nevertheless, certain recommended proportions should be maintained for the strength and stability of the chimney.

7.2.2 The clear diameter of the chimney is the nominal diameter of the shell if the chimney is unlined or partially lined. For fully lined chimney the clear diameter shall be the clear diameter of the lining at the top. The fully lined chimney shall have a minimum clear diameter of 500 mm. If, for technological reasons, it is necessary to have a smaller diameter, the top opening shall be reduced by constricting the passage locally.

7.2.3 A self-supporting chimney of height 40 m and above shall be provided with a flare at the base to achieve better stability.

7.2.4 Proportions of the basic dimensions of a self-supporting chimney shall conform to the following:

- a) Minimum height of flare be equal to one-third the height of the chimney.
- b) Minimum outside diameter of unlined chimney shell at top be equal to one-twentieth of the height of cylindrical portion of chimney and for lined chimney it shall be one-twentyfifth of the height of the cylindrical portion.
- c) Minimum outside diameter of flared chimney shell at base be equal to 1.6 times the outside diameter of chimney shell at top.

7.3 Minimum Thickness of Steel

7.3.1 Chimney Shell

The minimum thickness of the structural chimney shell in single or multiple shell constructions, shall be the calculated thickness obtained from stress and deflection considerations plus the corrosion allowance (see 7.5), but shall not be less than 6.0 mm nor less than 1/500 of the outside diameter of the chimney at the considered height.

7.3.2 Chimney Liner

The minimum thickness of the steel liner in a double skin or multiple construction shall be the calculated thickness obtained from stress considerations plus the corrosion allowance, but shall be not less than 6.0 mm.

7.3.3 Supporting Steelwork

The minimum thickness for hot rolled sections used for external construction exposed to the weather shall be 8.0 mm, and for constructions not so exposed and ancillary steelwork, 6.0 mm. These provisions do not apply to the webs of Indian Standard rolled steel sections or to packings. The minimum thickness of hollow sections sealed at the ends, used for external constructions exposed to the weather or other corrosive influences shall be 4 mm, and for constructions not so exposed shall be 3 mm.

7.3.4 Angle Flanges

The minimum thickness of jointing flanges to chimney shall be 6.0 mm.

7.4 Allowable Deflection

The maximum deflection at the top of the steel chimney produced by the wind load without taking into account the dynamic factors, calculated as acting on the circular cross section shall not be greater than $h/200$. Where 'h' is the unsupported height of the chimney.

7.5 Allowance for Corrosion

The total allowance for corrosion shall be the sum of the external (T_{ce}) and internal (T_{ci}) allowances given in Table 1. This total allowance shall be added to the thickness of shell obtained from the calculations of the stresses and deflection. Internal flanges shall have corrosion allowance T_{ci} , and external flanges corrosion allowance T_{ce} except if they are encased.

NOTE — However, a lower corrosion allowance than specified in Table 1 may be adopted at the discretion of the designer/owner, if it can be ensured that the properties of flue gas and its effect on the chimney shell will not adversely affect the safety requirements.

7.6 Effective Height of Chimney Shell

Effective height of chimney shall be as specified in Table 2.

Table 1 Corrosion Allowance T_{ce} and T_{ci} ,
(Clause 7.5)

Degree of Corrosion Expected	Corrosion Allowance, in mm			
	Copper Bearing Steel		Non-copper Bearing Steel	
	Design Life		Design Life	
	10 yrs	20 yrs	10 yrs	20 yrs
a) <i>External, T_{ce}</i>				
1) None (that is, paint, insulation, cladding or similar protection available always)	Nil	Nil	Nil	Nil
2) Above average (that is, unprotected)	1	2	1.5	3
b) <i>Internal, T_{ci}</i>				
1) None (such as, non-corrosive flue gases or the structural shells of multiflue chimney)	Nil	Nil	Nil	Nil
2) Average (such as, lined, insulated or natural gas fired)	1	2	1.5	3
3) Above average (such as, unprotected coal fired)	2	3	3	5

NOTES

- 1 The internal corrosion allowance for the exceptional degree of corrosion shall be as mutually agreed between the purchaser and the designer, based on the desired life of the chimney.
- 2 No corrosion allowance need be provided if the chimney shell is made of stainless steel.
- 3 Partly lining the inside chimney with stainless steel does not eliminate the possibility of corrosion because of the condensed effluent passing down to chimney. The same is not recommended.

Table 2 Effective Height of Chimney Shell
(Clauses 7.6 and C-1)

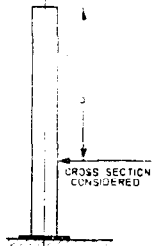
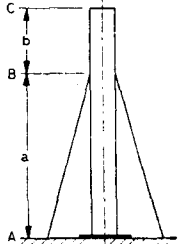
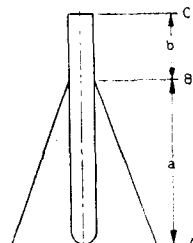
Description	Effective Height, h_e
Self-supporting chimney 	$h_e = H$
Supported chimney, fixed base 	For stresses in BC $h_e = b$ For stresses in AB $h_e = 0.85 a$
Supported chimney, pinned based 	For stresses in BC $h_e = b$ For stresses in AB $h_e = a$

7.7 Maximum Permissible Stress in the Shell

To control buckling, the compressive stress caused by the combination of extreme fibre stresses due to bending and direct load for the load combination given in 6.5, shall not exceed values specified in Table 3 for steels conforming to IS 226 : 1975 and IS 2062 : 1984. The values shall be reduced further if necessary for temperature and calculated with the corrosion allowance deduced from the thickness t .

7.7.1 For steels other than IS 226 : 1975 and IS 2062 : 1984, maximum permissible stresses shall be obtained by multiplying the values in Table 3 by the factor F_y/f_y , where F_y is the guaranteed yield stress of steel used and f_y is the guaranteed yield stress of steel conforming to IS 226 : 1975 and IS 2062, that is, 276 MPa.

7.7.2 The maximum permissible stresses given in Table 3 have been worked out in accordance with the formulae given in Annex C.

7.8 Allowance for Temperature

7.8.1 Maximum permissible stresses as obtained in 7.7 shall be corrected for the most adverse temperature conditions to which the member or part may reasonably be expected to be exposed by multiplying with the appropriate temperature coefficient K_t given in Table 4. The expected temperature of steel components shall not be allowed to exceed 400°C.

In case of steels other than IS 226 : 1975 and IS 2062 : 1984, maximum permissible stresses as obtained from 7.7.1, shall be reduced based on temperature coefficient factor K_t obtained by dividing yield stress at the operating temperature by the yield stress at 20°C.

7.9 Other Stresses in Steel

Allowable stresses in axial tension, shear and bearing shall be as specified in IS 800 : 1984.

7.10 Increase in Stresses

For load combination involving earthquake, the permissible stresses may be exceeded by 33½ per cent provided the steel thickness shall neither be less than the minimum thickness specified nor when the earthquake loads are neglected.

7.11 Allowance for Large Openings in Shell

The allowable stresses apply to the shell plates after due allowance for rivets and bolt holes. Where large apertures are cut in the shell plates, as for inlets or inspection panels, a structural analysis of the stresses shall be made and compensating material provided, as required, to ensure that the stresses specified in the standard are not exceeded. Apertures in the shell plates, other than flue inlets, shall have the corners rounded to a minimum radius of $10t$, where t is the thickness of the plate.

Table 3 Maximum Permissible Stress for Circular Chimneys
(Clauses 7.7, 7.7.1, 7.7.2 and C-1)

Ratio h_e/D	Maximum Permissible Stress in MPa, for D/t													
	140 and less	150	160	170	180	190	200	225	250	300	350	400	450	500
Up to 20	126	124	123	120	118	115	112	105	99	87	78	70	64	58
30	108	107	105	103	101	99	96	90	85	75	67	60	55	50
40	89	88	86	85	83	81	79	74	70	62	55	50	45	41
50	72	71	70	69	68	66	64	60	57	50	45	40	37	34
60	59	58	57	56	55	54	52	49	46	41	36	33	30	27
70	48	48	47	46	45	44	43	40	38	33	30	27	24	22
80	40	40	39	38	37	37	36	33	31	28	25	22	20	19
90	33	33	33	32	31	31	30	28	26	23	21	19	17	16
100	28	28	28	27	26	26	25	24	22	20	18	16	14	13
110	24	24	24	23	23	22	22	20	19	17	15	13	12	11
120	21	21	20	20	19	19	19	17	16	14	13	12	11	10
130	18	18	18	17	17	17	16	15	14	13	11	10	9	8
140	16	16	15	15	15	15	14	13	12	11	10	9	8	7
150	14	14	14	13	13	13	13	12	11	10	9	8	7	7

t = thickness of the plate of the level considered,
 D = mean diameter at the level considered (in metres), and
 h_e = effective height for consideration of buckling in m.

NOTE — Intermediate values may be linearly interpolated.

Table 4 Temperature Coefficient, K_t
(Clause 7.8.1)

K_t	Temperature, °C				
	0-200	250	300	350	400
	1.0	0.75	0.67	0.6	0.5

NOTE — Intermediate values shall be linearly interpolated.

7.12 Deflection Stresses

If the chimney carries a vertical load other than its own weight, due for example, to the reaction of guys, lining or an imposed vertical load so that an appreciable compressive stress results, deflection due to wind may cause the axial load to become eccentric, the bending moment so produced shall be determined, added to that from the windload and any other live or dead load and used to calculate the combined stress which shall not exceed those specified in 7.8. This procedure is necessary only if the total axial load produces stresses greater than one-third of the bending stress due to wind.

7.13 Factor of Safety for Guy Ropes and Fittings

A minimum factor of safety of 3 shall be adopted in the design of guy ropes and other fittings.

7.13.1 For guyed chimney, it is necessary to establish the safety of the chimney shell and guys for the forces induced due to temperature effect.

7.14 Foundation

The foundation shall be designed for the worst combination of loads specified in 6, such that the resulting pressure on the subsoil by considering the dead weight, movements and horizontal forces, is limited to safe bearing capacity of the soil. Necessary care should be taken on the effects of the temperature and seasonal changes.

8 DESIGN CALCULATION

8.1 General

Design of chimney shall be such that the stresses in any part of the chimney do not exceed the values specified in 7 for the loads and load combinations given in 6.

8.2 Calculation of Static Wind Load

8.2.1 Static wind pressure, q , acting normal to the surface of chimney shall be taken as specified in IS 875 (Part 3) : 1987 for the appropriate wind zone, terrain and topography.

8.2.2 To determine the wind force acting at different heights of chimney, the latter shall be divided into a number of convenient zones such that the number of zones shall not be less than three and the zone height shall not exceed 10 m.

8.2.3 Static wind force acting at the midpoint of K^{th} zone (K varying from 1 to r) shall be calculated from the formula,

$$P_{st,k} = C q_k h_k d_k$$

where $P_{st,k}$ = static wind load acting at the midpoint of K^{th} zone, in N;

q_k = static wind pressure at the midpoint of K^{th} zone, in Pa;

h_k = height of K^{th} zone strip, in metres;

d_k = external diameter of chimney of K^{th} zone, in metres taking into account strakes, if fitted. For chimney with strakes, this shall be 1.2 times the external diameter of the chimney shell; and

C = shape factor for chimney which may be taken as 0.7 for the portion with circular cross section, without strakes.

NOTE — For other shapes, surface conditions, attachments, line platform, hand rails and for groups of chimneys on suitable shape factors shall be taken.

8.3 Calculation of Dynamic Wind Loads

8.3.1 In case of self-supported chimneys, if the period of natural oscillation for the chimney computed as given below exceeds 0.25 seconds, the design wind loads shall take into consideration the dynamic effect due to pulsation of thrust caused by wind velocity in addition to the static wind load calculated under 8.2.3.

The natural frequency, first mode, for a chimney of varying diameter or thickness, shall be calculated by dividing the chimney into a number of convenient zones as given in 8.2.2.

$$\text{The frequency } f = \frac{1}{2\pi} \left[\frac{g \sum (mx)}{\sum (mx^2)} \right]^{\frac{1}{2}}$$

where

m = mass of the zone including the lining or covering, in kg;

x = deflection of the same zone due to the force equal to gravity acting on its mass normally at the mass centre with the base fixed and top free, in metres; and

g = rate of gravitational acceleration = 9.8 m/s².

8.3.2 Dynamic effect of wind is influenced by a number of factors, such as, mass and its disposition along chimney height, period and mode of natural oscillation, logarithmic decrement of dampening, pulsation of velocity thrust, etc. Values of dynamic components of wind load should be determined for each mode of oscillation of the chimney as a system of inertia forces acting at the centre of the zone being considered.

Inertia force P_{dyn} in N acting at the centre of the j th zone of the chimney in the i th mode of natural oscillation is determined as follows (see Fig. 1):

$$P_{dyn, ij} = M_j \xi_i \eta_{ij} v$$

where

M_j = mass of the j th zone in kg concentrated at its centre,

ξ_i = dynamic coefficient in accordance with 8.3.3,

η_{ij} = deduced acceleration in m/s^2 of the centre of the j th zone taken in accordance with 8.3.4, and

v = coefficient which takes care of the space correlation of wind pulsation speed according to height and vicinity of building structures and is taken in accordance with 8.3.5.

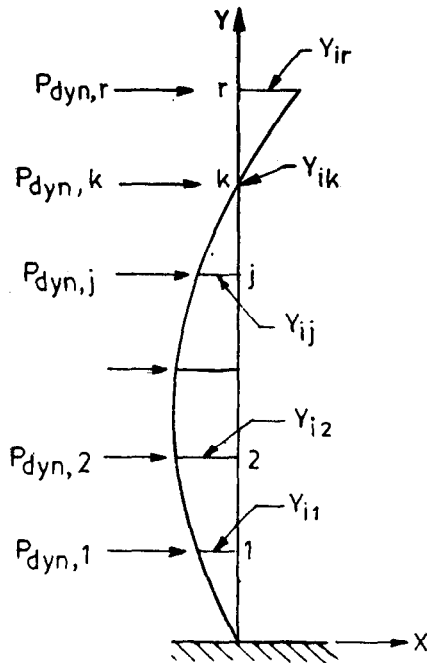

FIG. 1 DESIGN SCHEME OF CHIMNEY IN THE i th MODE OF OSCILLATION.

8.3.3 Dynamic coefficient ξ_i (for lined and unlined chimney) is determined from Table 5 depending on the parameter ξ_1 :

$$\xi_i = \frac{T_1 V_b}{1200}$$

T_1 = period of i th mode of natural oscillation in seconds, and

V_b = basic wind speed in m/s .

Table 5 Coefficient of Dynamic Influence ξ_1 for Steel Chimneys (Clause 8.3.3)

ξ_1	Values of ξ_1 for	
	Lined Chimney	Unlined Chimney
0	1.20	1.30
0.025	1.70	2.50
0.050	1.90	3.10
0.075	2.10	3.50
0.100	2.30	3.75
0.125	2.45	4.10
0.150	2.60	4.30
0.175	2.70	4.50
0.200	2.75	4.70

NOTE — Intermediate values may be linearly interpolated.

8.3.4 Deduced acceleration η_{ij} , in m/s^2 is determined according to formula:

$$\eta_{ij} = \frac{Y_{ij} \sum_{k=1}^r Y_{1k} P_{st,k} m_k}{\sum_{k=1}^r Y_{1k}^2 M_k}$$

where

M_k = mass of the k th zone, in kg;

Y_{ij}, Y_{1k} = relative ordinates of mode shape corresponding to the centres of j th and k th zones in the i th mode of oscillation. In special cases involving the interaction of soil structure affecting the mode shape considerably, the relative ordinates shall be accordingly calculated;

$P_{st,k}$ = wind load on the k th zone determined according to 8.2.3;

r = number of zones into which the chimney is divided; and;

m_k = coefficient of pulsation of speed thrust for the centre of the k th zone, taken as in Table 6.

8.3.5 The value of coefficient v shall be taken from Table 7 depending upon the parameter ξ_i as given in 8.3.4. For structures of cantilever type, v shall be taken only for the first mode of natural oscillation. For higher modes, v shall be taken as 1.

8.3.6 While determining the wind load on the chimney, consideration of the first mode of natural oscillation is sufficient. It is recommended to consider higher modes of oscillation only when the chimney is very tall, say, 80 and above and when consideration of mass, stiffness and disposition of various loads acting on the chimney require a more thorough analysis.

Table 6 Coefficient of Pulsation of Speed Thrusts, m_k
(Clause 8.3.4)

Type of Location	Height Above Ground Level, in m						
	Up to 10	20	40	60	100	200	350 and above
A	0.60	0.55	0.48	0.46	0.42	0.38	0.35
B	0.83	0.75	0.65	0.60	0.54	0.46	0.40

NOTES
 1 Type A relates to open locations (Steppe, desert, sea coast, lake, reservoir, etc).
 2 Type B relates to outskirts of town, widespread forest and its like, regular obstacles of height more than 10 m.

Table 7 Coefficient ν
(Clause 8.3.5)

ξ_1	Height of Chimney, in m					
	Up to 45	60	120	150	300	450 and above
≤ 0.05	0.70	0.65	0.60	0.55	0.45	—
0.1	—	0.75	0.65	0.60	0.50	0.40
0.2	—	—	0.75	0.70	0.60	0.50

NOTE — Intermediate values may be linearly interpolated.

8.3.7 Total design lateral force (P_k), bending moment (M_k) and deflection (Y_k) due to wind load should be computed from static and dynamic calculations corresponding to the i th mode of natural oscillation and summed up according to the following formulae:

$$P_k = P_{st,k} + \sqrt{\sum_{i=1}^s (P_{dyn,i,k})^2}$$

$$M_k = M_{st,k} + \sqrt{\sum_{i=1}^s (M_{dyn,i,k})^2}$$

$$Y_k = Y_{st,k} + \sqrt{\sum_{i=1}^s (Y_{dyn,i,k})^2}$$

where

$P_{st,k}$ and $P_{dyn,k}$ = the static and dynamic wind load acting at mid point of k th zone, respectively;

$M_{st,k}$ and $M_{dyn,k}$ = bending moments due to the static and dynamic wind pressure respectively, acting at k th zone;

$Y_{st,k}$ and $Y_{dyn,k}$ = deflections due to static and dynamic wind pressure respectively at the k th zone with respect to the original position; and

s = number of modes of oscillation.

8.4 Check for Resonance

8.4.1 In case of self-supporting chimney, checking for resonance shall be carried out if the critical velocity V_{cr} as determined from Annex A is within the range:

- a) 0.5 to 0.8 times the design wind velocity for lined chimneys, and
- b) 0.33 to 0.8 times the design wind velocity for the unlined chimneys.

8.4.2 For lined chimneys, checking for resonance should be carried out for both the cases, that is, with and without lining.

8.4.3 Design force F , bending moment M and deflection Y at level z during resonance shall be determined by formulae:

$$F = \sqrt{F_{res,z}^2 + (F_{st,z} + F_{dyn,z})^2}$$

$$M = \sqrt{M_{res,z}^2 + (M_{st,z} + M_{dyn,z})^2}$$

$$Y = \sqrt{Y_{res,z}^2 + (Y_{st,z} + Y_{dyn,z})^2}$$

where

$F_{res,z}$, $M_{res,z}$ and $Y_{res,z}$ = transverse force, bending moment and deflection at resonance respectively at level z (see A-5);

$F_{st,z}$, $M_{st,z}$ and $Y_{st,z}$ = static transverse force, bending moment and deflection due to static wind load (see A-6); and

$F_{dyn,z}$, $M_{dyn,z}$ and $Y_{dyn,z}$ = dynamic transverse force, bending moment and deflection due to dynamic wind load (see 8.3.2).

8.5 Holding Down Bolts

The maximum stress in holding down bolts calculated taking into account the worst combination of loading shall not exceed the permissible stresses as specified in IS 800 : 1984.

8.6 Design of Base Plate

The maximum stresses in the base plate and stiffeners and bearing pressure on foundation shall be calculated for the worst combination of loading and shall not exceed the permissible values in accordance with the relevant provisions of IS 800 : 1984 and IS 456 : 1978.

9 STABILITY

9.1 Structure

9.1.1 The stability of the structure as a whole or any part of it shall be investigated and calculations shall be made to show that the stresses imposed by 1.6 times the total of wind load plus any stress increasing imposed loads, less 0.9 times the minimum dead load excluding any stress reducing imposed loads, will not exceed 1.8 times the allowable stress specified.

$$1.6 (\sigma_w + \sigma_m) - 0.9 \sigma_e < 1.8 \sigma_a$$

where

σ_w = stress produced by wind load,

σ_m = stress produced by any other load which may act to increase the combined stress,

σ_e = stress produced by dead load and any other load which acts at all times and will reduce the combined stress, and

σ_a = maximum permissible stresses at the operating temperature.

9.1.2 To ensure stability at all times, account shall be taken of probable variations in dead load during construction, repair or other similar work.

9.1.3 While computing the stability, it shall be ensured that the resulting pressure and shear forces to be transferred to the supporting soil through foundation, will not cause failure of foundation.

9.2 Structure and Foundations

9.2.1 In the case of guyed or laterally supported chimneys, the stability of the structure and foundation as a whole or any part of it shall be investigated and weight or anchorage shall be provided so that, without exceeding the allowable material stresses and foundation bearing pressure, 0.9 times the least restoring moment including anchorage will not be less than the sum of 1.1 times the maximum overturning moment due to stress-increasing dead loads, less 0.9 times that due to stress-reducing loads, plus 1.4 times that due to wind and imposed loads, that is

$$1.4 M_w + 1.1 M_m - 0.9 M_e < 0.9 M_a$$

where

M_w = overturning moment produced by the wind and imposed loads,

M_m = overturning moment produced by dead or other loads which may act to increase combined moment,

M_e = overturning moment produced by dead or other loads which act at all times to reduce combined moment, and

M_a = resisting moment produced by the foundation without exceeding the allowable material stress and the ground stress without exceeding the foundation bearing pressure.

9.2.2 In the case of self-supporting chimney, the stability of the structure as a whole shall be investigated and weight or anchorages shall be so proportioned that the least resisting moment shall be not less than the sum of 1.5 times the maximum overturning moment due to dead load and wind load/earthquake load.

10 MISCELLANEOUS COMPONENTS

10.1 Base Plate and Holding Down Bolts

Holding down bolts shall be adequately tightened with appropriate precautions using washers and locknuts to prevent the stripping of threads and the base plate shall be properly grouted. Typical details of base plate and holding down bolts are shown in Fig. 2.

10.2 Base Gussets and Stools

Where base gussets or stools are used, they should preferably be evenly disposed around the chimney shell. Smaller secondary gussets may be provided between the main gussets. Base gussets shall be of ample height and shall extend to the edge of the base plate. The angle of the sloping edge of any gusset to the horizontal shall be not less than 60°. The minimum thickness of the gusset shall be 8 mm.

10.3 Chimney Head

The chimney head shall be strengthened in a suitable manner on the basis of the design and shall have provisions for the attachment of erection and maintenance equipment.

10.4 Galleries and Platforms

Galleries and platforms for erection and service of warning lamps, earthing, inspection, etc, should be provided around the chimney wherever necessary. Their width shall be at least 800 mm. These shall be provided with handrails of height, I_m . The number and location of galleries and platforms may be mutually decided between the designer and the customer.

10.5 Inspection/Cleaning Door

Suitable door for access near the base, to the inside of the chimney shall be provided for the purpose of inspection of the inside of the chimney and also for ash removal. The minimum size of the door opening shall be 500 mm wide × 800 mm high clear (see Fig. 3).

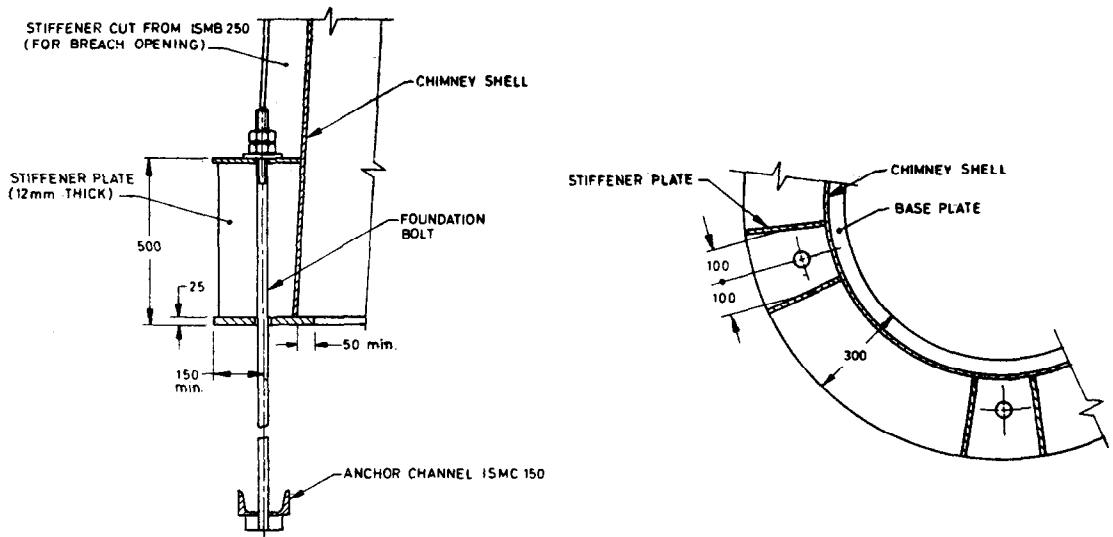

2A WELDED BASE

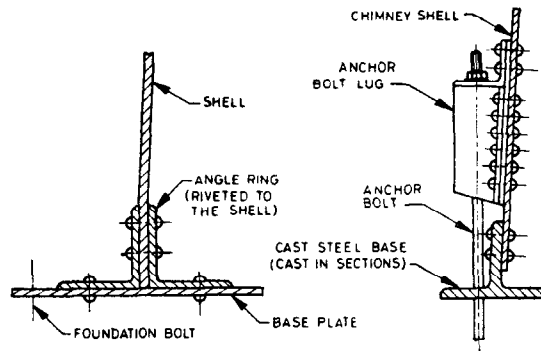

2B RIVETED BASE

All dimensions in millimetres.

FIG. 2 TYPICAL DETAILS OF BASE OF STEEL CHIMNEY

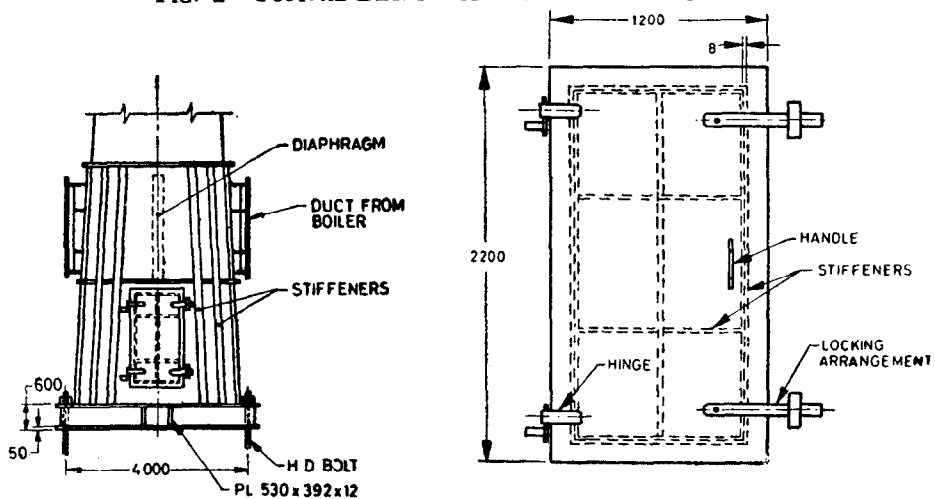

ENLARGED VIEW SHOWING CHIMNEY DOOR AND BOILER DUCTS

DETAIL OF DOOR

All dimensions in millimetres.

FIG. 3 TYPICAL DETAILS OF CHIMNEY DOOR AND BOILER DUCTS

10.6 Protection Against Lightning

The chimney shall be provided with lightning protection arrangements in accordance with IS 2309 : 1963.

10.7 Warning Lamps

Suitable warning lamps shall be provided. The recommended number and position of the same, depending upon the height of the chimney is given in Fig. 4. Whenever only one warning lamp is shown in the figure, 2 numbers of lamps have to be provided diametrically opposite to each other.

10.7.1 Existing local and aviation regulations, if any, should be followed (see 3.1 also).

10.8 Baffle Plates

When there are two or more breach openings or flues entering the chimney, baffle plates shall be provided to properly direct the gases from flue duct up the chimney and prevent them from interfering with the operation of the other flue. These baffles shall be properly insulated.

10.9 Rigging Screws (Turn Buckles)

Rigging screws shall conform to IS 3121 : 1965. These shall be provided with lock nuts to prevent slacking back.

10.10 Steps and Ladders

10.10.1 Steps

10.10.1.1 Typical connection details of steps to chimney shell are shown in Fig. 5.

10.10.1.2 The steps shall be welded to the outside of the chimney at a spacing of 3 000 mm. In the case of shafts of clear diameter of 300 mm and more, a second row of steps shall be welded on the diametrically opposite side. Proper anticorrosive measure or alternatively, proper selection of material for the steps shall be adopted keeping in view the location in the chimney and the extent of corrosion involved.

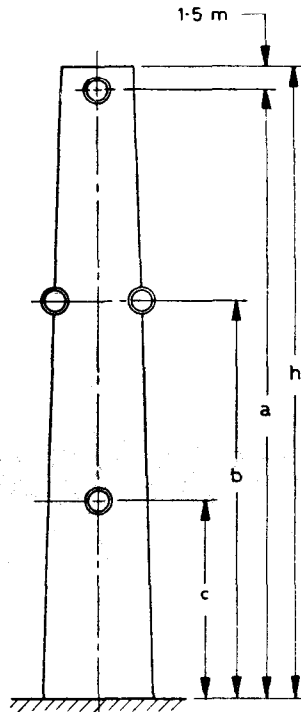

Position of Lamp	Height of Lamp in m for Chimney Height h							
	32.00	56.00	63.00	70.00	80.00	90.00	100.00	110.00
a	30.50	54.40	61.00	68.50	78.50	68.50	98.50	108.00
b	—	27.00	31.50	33.50	98.50	43.50	48.50	73.50
c	—	—	—	—	—	—	—	38.50

All dimensions in millimetres.

FIG. 4 LOCATION OF WARNING LAMPS ON THE CHIMNEY

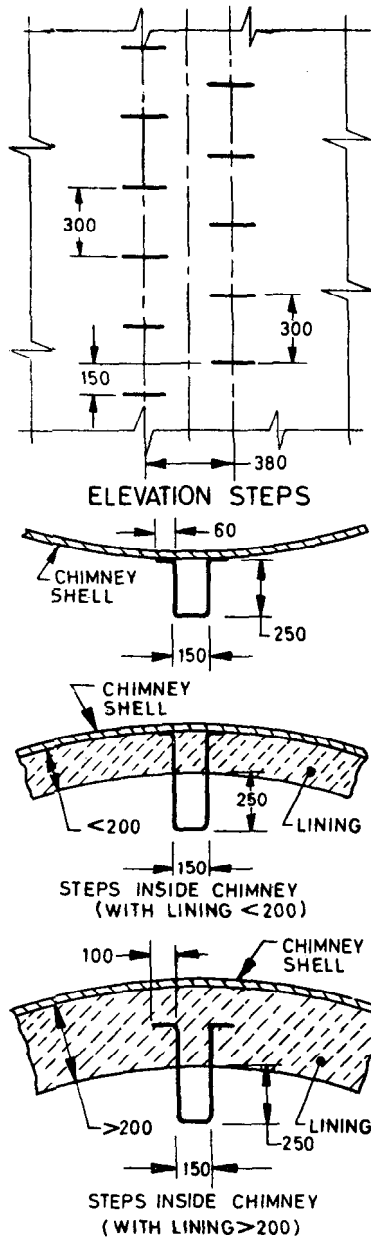

All dimensions in millimetres.

FIG. 5 STEPS FOR STEEL CHIMNEYS

10.10.1.3 On the inner side of the chimney, steps may be welded at a spacing of 300 mm. If the steps are to be directly supported on the lining, the lining should have a minimum thickness of 200 mm. Where the lining is thinner than the above, the steps shall be welded direct to the shell with adequate clearance when the lining does not expand along with the shell. In case where the diameter does not permit providing steps inside, painter's trolley should be used for approach.

10.10.2 Ladders

Typical connection details of ladders are shown in Fig. 6.

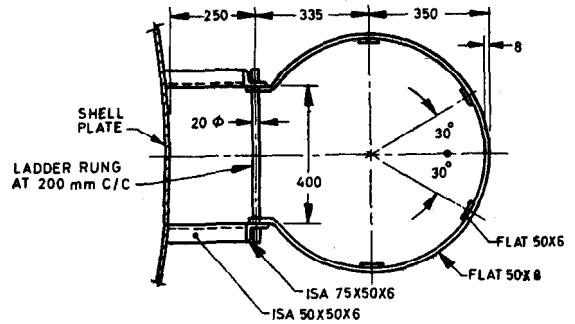

All dimensions in millimetres.

FIG. 6 TYPICAL CONNECTION DETAILS FOR LADDER

10.10.2.1 Steel ladders may also be provided in addition to steps. Safety enclosure or cage shall be provided for chimneys taller than 20 m starting from a height of 3 m from ground.

10.10.2.2 If individual section of a ladder exceeds 20 m in height, an intermediate landing platform shall be provided.

10.11 Position of Guys

10.11.1 Guys shall be positioned sufficiently below the outlet of the chimney to avoid the corrosive action of the emergent combustion products. A minimum distance of 3 m is recommended. There shall be a minimum of three guy ropes to each set, guys shall be positioned radially in plan and the angle between any adjacent pair of guys shall not exceed 130°. The guy ropes shall not exceed an angle of 60° to the horizontal.

11 CONSTRUCTION

11.1 General

The fabrication and erection of steel chimneys, guys, etc, shall generally be in accordance with IS 800 : 1984. For welded chimneys, welding shall be carried out in accordance with IS 816 : 1969 and IS 9595 : 1980.

11.1.1 Non-destructive testing of weld, if required, may be carried out as mutually agreed between the parties concerned.

11.2 Erection Tolerance

The variation in the eccentricity of the axis of chimney from the vertical at any level shall not exceed 1/1 000 of the height, at that particular section.

11.3 Clearance

Where a chimney passes through a roof or other part of a building, provision shall be made to

accommodate the movement of the chimney and to limit the transfer of heat. Normally, an air gap of 50 mm is desirable. Flexible heat resistant packing may be used to fill the gap, if necessary.

11.4 Sealing

Riveted chimneys shall be caulked, specially if condensation is likely to occur.

11.5 Gas Tightness

No gaskets shall be used in jointing flanges on structural steels.

NOTE — Liquid sealants are recommended to ensure gas tightness and prevent corrosion in the meeting faces.

10.6 Erection Tension

The amount of pretensioning applied to the guy ropes on site shall be in accordance with the appropriate design considerations and may be measured with a suitable instrument. The tension in the guys after erection shall be not less than 15 percent nor more than 30 percent of the calculated maximum tension due to wind.

12 INSPECTION AND MAINTENANCE

12.1 All steel chimneys shall be inspected and examined at least once a year.

12.1.1 In case of uninsulated and unlined steel chimneys, the thickness of the shell should be determined by either ultra-sonic thickness testing or by drill testing. At the same time, any decorative or other surface finish on the exterior of the chimney may be examined. The internal surface of large diameter steel chimneys may also be inspected preferably by close examination from a painter's trolley or similar means of support.

12.1.2 Lined chimneys should also be inspected internally by close examination from a painter's trolley or similar means of support to ascertain that the lining is still in serviceable condition and fulfilling its task.

12.2 The details of the painter's trolley are given in Fig. 7 for information. For chimney of diameter exceeding 3 m at the top, two such painter's trolleys should be provided.

12.3 Flanges should be inspected to see if there is a build-up of rust between them as the pressure of rust build-up can overload the bolts/rivets in tension. In bolted connections, particular attention should be given to the conditions of the bolts. Selected bolts in critical areas should be removed, inspected, tested as necessary and be replaced with the new bolts. Should the examined bolts be serviceable, these shall not be reused.

12.4 The rivet heads on the interior of riveted chimney should be examined to ascertain that they are secure and have not eroded to a dangerous degree.

12.5 Where loose fill is used for insulation, this should be inspected at three monthly intervals in the first 12 months and then annually. The loose fill should be checked to ensure that it has not compacted and, if necessary, it should be topped up.

12.6 Detailed record should be submitted after each inspection describing any recommended maintenance.

12.7 Guy wire and fittings, where present, should be examined for security tension and, if necessary, be cleaned and greased.

13 PROTECTIVE TREATMENTS

13.1 Surface Preparation for Painting

Consideration should be given to the surface preparation and protective treatment of both the exterior and interior surfaces of chimney shells in order to prolong the life and improve the appearance of the chimney. Immediately before applying any protective treatment to the exterior or the interior surface of a steel chimney shell, the surface shall be cleaned by chipping, scrapping and wire brushing, or by other means to remove all dirt, loose scale, grease, rust or other deleterious materials.

13.1.1 Pretreatment and painting of chimney shell parts shall generally conform to the requirements of IS 1477 (Part 1) : 1971 and IS 1477 (Part 2) : 1971.

13.2 Painting of Interior Surfaces

13.2.1 Unlined Chimney Shell

There is generally no advantage in applying a protective treatment except for the application of one coat of suitable priming paint to the interior surface of an unlined chimney shell unless it can be shown that such treatment will withstand the corrosive, abrasive and thermal effects of the flue gases and thus prolong the life of the chimney.

13.2.2 Lined Chimney Shell

When it is thought desirable to use a protective treatment on the interior steel surface of a lined chimney, such treatment shall consist of the application of one coat of a suitable priming paint followed by two coats of a finishing paint or paints applied in accordance with the instructions of the manufacturer.

13.2.3 Multiflue Chimney Shells

The interior surface of the structural shell of a multiflue chimney shall be given one coat of a suitable paint, applied in accordance with the instructions of the manufacturer.

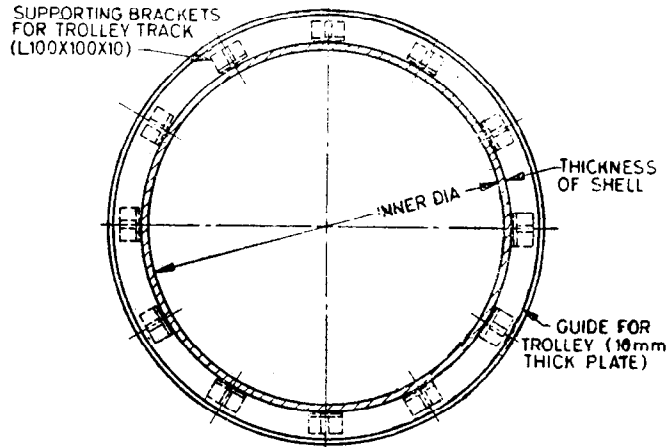
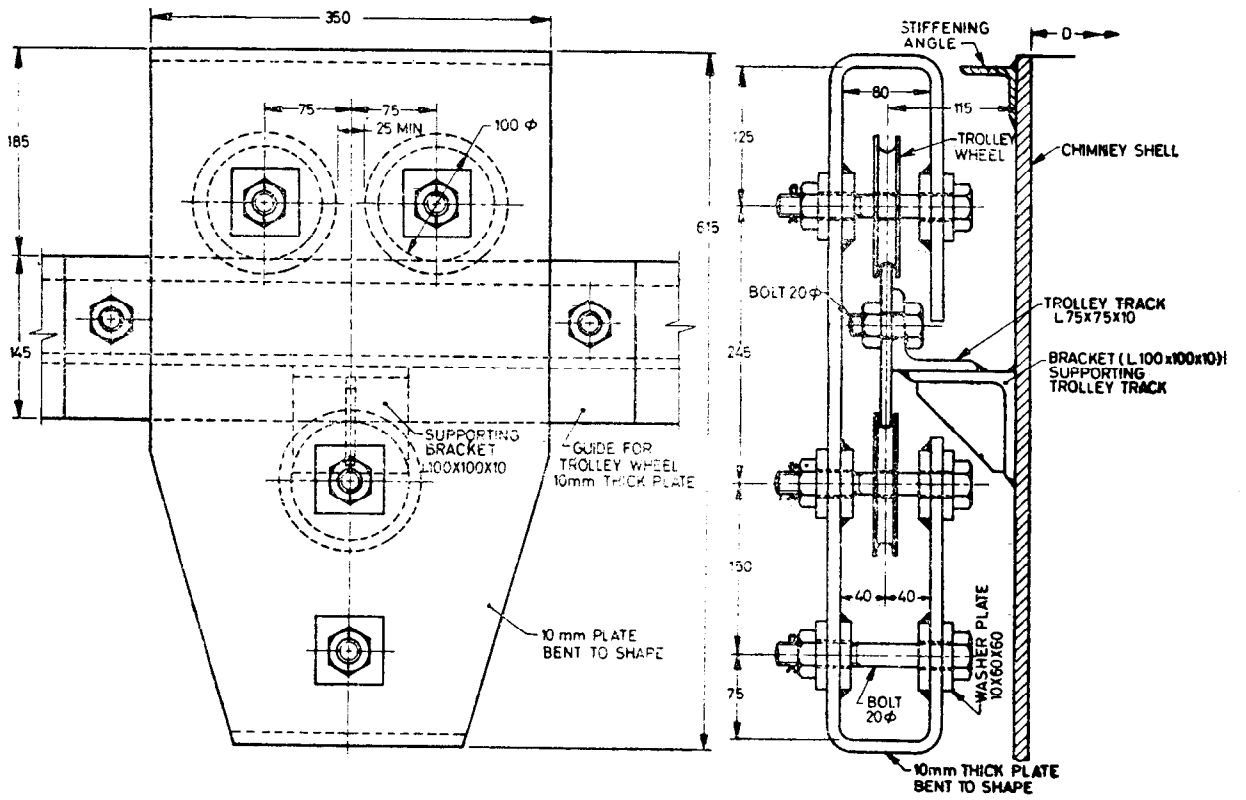

Trolley Track

All dimensions in millimetres.

FIG. 7 TYPICAL DETAILS OF PAINTER'S TROLLEY ARRANGEMENT

13.2.4 Chimney Shells with Monolithic Linings

The interior steel surface of a chimney which is to be given a monolithic lining needs no further protective treatment. The surface shall, however, be clean and dry immediately before the application of the lining.

13.3 Painting of Exterior Surfaces

13.3.1 Exposed Steel Sheet

Immediately after the surface preparation outlined in 13.1 has been completed, the exterior surface shall be given a coat of suitable priming paint followed by one coat of finishing paint applied in accordance with the recommendations of the manufacturer of the particular paint. A final coat of paint shall be applied after erection.

Special attention should be paid to the upper portion of the exterior surface, that is, for a distance of 1 to 2 times the chimney diameters down from the top where only those protective treatments should be applied which are best able to withstand the corrosive action of the emerging flue gases.

13.3.2 Shell with External Cladding

Shells with external cladding shall comply with 13.3.1 except where the cladding or insulation is fitted at the works in which case the final coat of paint may be omitted.

13.3.3 Multi-Flue Chimney Framework

Where a framework forms supporting structure of a multi-flue chimney, the treatment described in 13.3.1 shall be applied.

13.4 Metal Spraying

13.4.1 General

The exterior of a steel chimney may be protected from atmospheric corrosion by the application of a sprayed metal coating. Aluminium is the preferred metal for this application (certain other metals have disadvantages when used for hot surfaces).

The initial metal spray treatment shall be applied under controlled conditions before erection and care shall be taken to avoid damage during transportation and erection.

Regions of damage where the coating has been removed over an area, the maximum width of which exceeds 6 mm, shall be reblasted and re-sprayed, care being taken to avoid damaging or loosening the bond in contiguous areas. Minor areas of damage may be rectified by the application of a suitable aluminium paint after cleaning.

The finished appearance of sprayed chimneys may not be uniform shading or texture.

13.4.2 Specifications

Surface preparations and metal spraying shall be done in accordance with the requirements stipulated in IS 6586 : 1972. Recognized practices depending on the surface temperature of shell may also be taken in account.

13.4.3 Surface Preparation

13.4.3.1 It is essential that the blast-cleaned surface is sufficiently rough and clean to provide an adequate key for the sprayed aluminium coating. The amplitude of the blast cleaned surface shall be (0.1 ± 0.05) mm.

13.4.3.2 Compressed air for nozzle blast cleaning shall be effectively free from oil and moisture. The pressure during the blasting process shall be not less than 400 kPa at the nozzle.

13.4.4 Methods of Application and Sealing of Coatings

13.4.4.1 For shell temperatures up to 200°C, the aluminium spray shall be applied by the electric arc or flame spraying process.

13.4.4.2 For shell temperatures exceeding 200°C, the aluminium coating shall normally be applied by the electric arc process. The flame spraying process may be used if the chimney is not to be subjected to thermal shocks frequently produced by gas turbine exhausts.

The spray shall be sealed with a suitable silicone based high temperature paint, applied as a flood coat.

13.4.4.3 The nominal thickness of the coating shall be not less than 0.18 mm.

13.4.4.4 Sealing coats

The sprayed aluminium coating shall be sealed. For temperatures not exceeding 150°C, certain organic base sealers or paints are suitable. Special high temperature resistant paints shall be selected for use at temperatures exceeding 150°C, that is, resin-modified silicone base paints. Silicone base paints shall be used according to the manufacturer's instructions.

13.4.4.5 Application of sealing coats

Sealing coats shall be applied to clean dry surfaces. Any oil, grease or other contaminants shall be removed by thoroughly washing with thinners until no visible traces of contamination exist and the surface shall be allowed to dry for at least 15 minutes before applying the coating. Sealing coats shall be applied heavily enough to produce a wet appearance and shall be applied in accordance with the manufacturer's instructions. The treatment shall be applied at the contractor's works as soon as practicable after spraying.

ANNEX A

(Foreword and Clauses 8.4.1 and 8.4.3)

WIND EXCITED OSCILLATIONS

A-1 GENERAL

Chimneys are subject to oscillation due to wind action. This annex explains the procedures to include the effects of wind excited oscillations as enumerated and suggests alternative procedures for making an appropriate increase in the design wind loading and indicates when strengthening or the incorporation of devices for suppressing von Karman type of oscillations is advisable.

A-1.1 It has been found that chimneys of circular cross section oscillate strongly across wind than along wind. It is, therefore, reasonable to continue with the current practice which implies that along wind, the oscillation will not cause stresses greater than those calculated for the wind velocities as specified in IS 875 (Part 3) : 1987 due to static loading along with dynamic coefficient proposed in this standard.

A-1.2 Lateral oscillation due to resonance effects within the critical wind speed range at the natural period of a cylindrical structure may be great enough when its effect is added vectorially to the down wind deflection, to cause stresses higher than those calculated for the short duration wind velocities in accordance with this code due to static loading along with the dynamic coefficient as specified in this standard.

A-2 VON KARMAN VORTEX SHEDDING

The regular fluctuating side force due to commonly known as Von Karman vortex shedding, which may be produced in a smooth air flow, will produce strong oscillation at a velocity which gives resonance with the natural frequency of the structure. This effect is resisted by high damping and may be prevented by helical strakes or other devices attached to a circular chimney. If the tendency is strong, it is not effectively withstood by increase of strength alone.

A-2.1 In a natural wind, the regular vortex shedding may be interfered with by fluctuation of the wind so that the build-up of amplitude is not continuous as in a wind tunnel, and it may be more effectively resisted by mass and stiffness. There are different views as to how the vortex shedding should be allowed for in practice but it is clear that low damping, low mass and large flexibility must increase the probability and the amount of the oscillation of chimneys. In many cases, the behaviour cannot be predicted with certainty.

A-2.2 Even in the worst cases, a chimney can be made safe by applying guys or strakes at any time

after construction if experience shows them to be required, and provided that the chimney is made strong enough in the first place to withstand the additional load from guys or strakes applied later.

For instance, helical strakes of three rails having a projection of 0.1 to 0.12 times the diameter of the chimney, wound, equally spaced, round the perimeter of the shell at a pitch of about five times the diameter of the chimney for not less than the upper one-third of it.

A-3 STROUHAL CRITICAL VELOCITY

Severe Von Karman type oscillation is not likely if the calculated velocity, known as 'the critical strouhal velocity', is greater than the maximum design velocity based on IS 875 (Part 3) : 1987. The strouhal critical velocity V_{cr} in m/s for a circular chimney may be calculated from the formula:

$$V_{cr} = 5 D_t \times f \quad \dots (1)$$

where

f = natural frequency of the chimney (in Hz) as obtained in 8.3.1, and

D_t = diameter of chimney at top (in mm).

NOTE — The formula for V_{cr} holds good for strouhal number of 0.2. This value remains fairly constant as shown by experiments.

A-4 AERODYNAMIC FORCE

For checking of resonance amplitude, the intensity of aerodynamic force $F_1(z)$ at level z , for the i th mode of oscillation is determined by the formula:

$$F_1(z) = F_{e1}(z) Y_1(z) \quad \dots (2)$$

where

$Y_1(z)$ = relative ordinate at level z in the i th mode oscillation;

$F_{e1}(z)$ = amplitude of force intensity at the free end of the self-supporting chimney or at the centre of the span of guyed chimney and is equal to C_y, q_{cr}, d_z, h_z ;

C_y = coefficient of transverse force taken equal to 0.25;

q_{cr} = speed thrust corresponding to critical velocity V_{cr} and is equal to $\frac{V_{cr}^3}{16}$;

d_z = diameter of the chimney at level z and z is in metres; and

h_z = height of the zone at level z .

A-4.1 For self-supporting chimney (cantilever type structures), only the first mode of oscillation shall be considered.

A-5 Inertia forces, amplitude of resonance oscillations and dynamic bending moment at a section under consideration of a chimney fixed at foundation are determined by the following formulae:

$$F_{res,z} = \frac{\pi}{\delta} F_{st,z} \quad \dots (3)$$

$$Y_{res,z} = \frac{\pi}{\delta} Y_{st,z} \quad \dots (4)$$

$$M_{res,z} = \frac{\pi}{\delta} M_{st,z} \quad \dots (5)$$

where

$F_{res,z}$ = intensity of inertia forces at resonance at level z ,

$Y_{res,z}$ = amplitude of resonance oscillation at level z ,

$M_{res,z}$ = bending moment at resonance at level z ,

$F_{st,z}$ = intensity of lateral static force at level z ,

$Y_{st,z}$ = static deflection at level z (section under consideration) under the action of static force,

$M_{st,z}$ = bending moment at level z (section under consideration) due to the action of static force,

δ = logarithmic decrement of dampening effect to be taken equal to:

a) 0.1 for steel chimney with lining, and

b) 0.05 for unlined steel chimneys.

A-6 Static wind load q_{cr} (stat) in the direction of action of wind corresponding to critical pressure q_{cr} is permitted to be taken as constant along the

height of the chimney and is calculated from the formula:

$$q_{cr} \text{ (stat) } = C q_{cr}$$

where

C = sape factor in accordance with **8.2.3**.

A-7 The corresponding dynamic wind load q_{cr} (dyn) shall be determined in accordance with **8.3.2** to **8.3.7** corresponding to q_{cr} .

A-8 Checking for resonance is not required for other short duration forces. The provisions for checking resonance will not necessarily apply to pairs, files and groups of chimneys or other tall structure which may oscillate excessively particularly if they are closer than approximately 12 diameters. The fitting of stabilizers is usually beneficial but may not always be effective. No simple rules can be suggested. Study of the layout by specialists and wind tunnel testing may be necessary.

A-9 Chimneys which have a high diameter/thickness ratio may be subjected to wind-generated ovaling oscillation due to circumferentially varying and fluctuating pressure. Besides causing circumferential bending stresses, this can increase vertical stresses in the lower part of a chimney of large diameter. It should be avoided by providing sufficient circumferential stiffness around chimney at the top. Chimneys having gross plate thickness of less than 1/300 of the diameter if not efficiently stiffened by a lining or encasing, should have stiffened rings added at the top (and lower down if the height is more than 20 times the diameter). The distance between the stiffening rings should be not more than 1 500 times the thickness of the shell and should be substantial enough to give a total circumferential bending stiffness at least equivalent to that of a uniform shell of thickness $\frac{1}{200}$ of the diameter.

ANNEX B

(Clause 2.1)

LIST OF REFERRED INDIAN STANDARDS

IS No.	Title	IS No.	Title
226 : 1975	Structural steel (standard quality) (fifth revision)	814	Covered electrodes for metal arc welding of structural steel:
456 : 1978	Code of practice for plain and reinforced concrete (third revision)	(Part 1) : 1974	For welding products other than sheets (fourth revision)
800 : 1984	Code of practice for general construction in steel (second revision)	(Part 2) : 1974	For welding sheets (fourth revision)

IS No.	Title	IS No.	Title
816 : 1969	Code of practice for use of metal arc welding for general construction in mild steel (<i>first revision</i>)	2141 : 1979	Galvanized stay strand (<i>second revision</i>)
875	Code of practice for design loads (other than earthquake) for building structures:	2155 : 1982	Cold forged solid steel rivets for hot closing (6 to 16 mm diameter) (<i>first revision</i>)
(Part 1) : 1987	Dead loads — Unit weights of building materials and stored materials (<i>second revision</i>)	2266 : 1970	Steel wire ropes for general engineering purposes (<i>second revision</i>)
(Part 3) : 1987	Wind loads (<i>second revision</i>)	2309 : 1963	Code of practice for the protection of buildings and allied structures against lightning (<i>first revision</i>)
961 : 1975	Structural steel (high tensile) (<i>second revision</i>)	3613 : 1974	Acceptance tests for wire-flux combinations for submerged-arc welding of structural steels (<i>first revision</i>)
1030 : 1982	Carbon steel castings for general engineering purposes (<i>third revision</i>)	3640 : 1982	Hexagon fit bolts (<i>first revision</i>)
1149 : 1982	High tensile steel rivet bars for structural purposes (<i>third revision</i>)	3757 : 1972	High strength structural bolts (<i>second revision</i>)
1363 : 1984	Hexagon head bolts, screws and nuts of product grade C	5369 : 1975	General requirements for plain washers and lock washers (<i>first revision</i>)
1364 : 1983	Hexagon head bolts, screws and nuts of product grades A and B	5370 : 1969	Plain washers with outside diameter 3 × inside diameter
1367	Technical supply conditions for threaded steel fasteners:	5624 : 1970	Foundation bolts
(Part 1) : 1980	Introduction and general information (<i>second revision</i>)	6419 : 1971	Welding rods and bare electrodes for gas shielded arc welding of structural steel
(Part 3) : 1979	Mechanical properties and test methods for bolts, screws and studs with full loadability (<i>second revision</i>)	6560 : 1972	Molybdenum and chromium-molybdenum low alloy steel welding rods and base electrodes for gas shielded arc welding
(Part 6) : 1980	Mechanical properties and test methods for nuts with specified proof loads (<i>second revision</i>)	6586 : 1972	Recommended practice for metal spraying for protection of iron and steel
1395 : 1982	Low and medium alloy steel covered electrodes for manual metal arc welding (<i>third revision</i>)	6610 : 1972	Heavy washers for steel structures
1477	Code of practice for painting of ferrous metals in buildings:	6623 : 1972	High strength structural nuts (<i>first revision</i>)
(Part 1) : 1971	Pretreatment (<i>first revision</i>)	6639 : 1972	Hexagon bolts for steel structures
(Part 2) : 1971	Painting (<i>first revision</i>)	6649 : 1972	Hardened and tempered washers for high strength structural bolts and nuts (<i>first revision</i>)
1893 : 1975	Criteria for earthquake resistant design of structures (<i>fourth revision</i>)	7002 : 1972	Prevailing torque type steel hexagon locknuts
1929 : 1982	Hot forged steel rivets for hot closing (12 to 36 mm diameter) (<i>first revision</i>)	7280 : 1974	Bare wire electrodes for submerged arc welding of structural steels
2062 : 1984	Weldable structural steel (<i>third revision</i>)	8500 : 1977	Weldable structural steel (medium and high strength qualities)

ANNEX C
(Clause 7.7.2)

ALLOWABLE COMPRESSIVE STRESSES

C-1 COMPRESSIVE STRESSES IN THE SHELL

C-1.1 To control buckling, the compressive stresses caused by the combination of extreme fibre stress due to buckling and direct load, as given in Table 3, are worked out by the formula:

$$0.5 f_y A \cdot B$$

where

f_y = yield stress of steel; 250 MPa for steel of IS 226 and IS 2062;

$$A = \frac{1}{0.84 + \left(0.019 \frac{h_e}{D} \right)^2}, \text{ if } \frac{h_e}{D} > 21$$

and

$$A = 1 \text{ if } \frac{h_e}{D} < 21$$

$$\text{and } B = 270 \frac{t}{D} \left(1 - 67 \frac{D}{t} \right), \text{ if } \frac{D}{t} > 130$$

and

$$B = 1, \text{ if } \frac{D}{t} < 130$$

t = thickness of plate at the level considered, in m;

D = mean diameter at the level considered, in m; and

h_e = effective height for the consideration of buckling, in m (see Table 2).

Bureau of Indian Standards

BIS is a statutory institution established under the *Bureau of Indian Standards Act*, 1986 to promote harmonious development of the activities of standardization, marking and quality certification of goods and attending to connected matters in the country.

Copyright

BIS has the copyright of all its publications. No part of these publications may be reproduced in any form without the prior permission in writing of BIS. This does not preclude the free use, in the course of implementing the standard, of necessary details, such as symbols and sizes, type or grade designations. Enquiries relating to copyright be addressed to the Director (Publication), BIS.

Review of Indian Standards

Amendments are issued to standards as the need arises on the basis of comments. Standards are also reviewed periodically; a standard along with amendments is reaffirmed when such review indicates that no changes are needed; if the review indicates that changes are needed, it is taken up for revision. Users of Indian Standards should ascertain that they are in possession of the latest amendments or edition by referring to the latest issue of 'BIS Handbook' and 'Standards Monthly Additions'.

This Indian Standard has been developed from Doc: No. CED 7 (4721)

Amendments Issued Since Publication

Amend No.	Date of Issue	Text Affected

BUREAU OF INDIAN STANDARDS

Headquarters:

Manak Bhavan, 9 Bahadur Shah Zafar Marg, New Delhi 110002
Telephones: 323 01 31, 323 33 75, 323 94 02

Telegrams: Manaksanstha
(Common to all offices)

Regional Offices:

Central : Manak Bhavan, 9 Bahadur Shah Zafar Marg
NEW DELHI 110002

Telephone
323 76 17, 323 38 41

Eastern : 1/14 C.I.T. Scheme VII M, V.I.P. Road, Maniktola
CALCUTTA 700054

{ 337 84 99, 337 85 61
{ 337 86 26, 337 91 20

Northern : SCO 335-336, Sector 34-A, CHANDIGARH 160022

{ 60 38 43
{ 60 20 25

Southern : C.I.T. Campus, IV Cross Road, CHENNAI 600113

{ 235 02 16, 235 04 42
{ 235 15 19, 235 23 15

Western : Manakalaya, E9 MIDC, Marol, Andheri (East)
MUMBAI 400093

{ 832 92 95, 832 78 58
{ 832 78 91, 832 78 92

Branches : AHMADABAD. BANGALORE. BHOPAL. BHUBANESHWAR.
COIMBATORE. FARIDABAD. GHAZIABAD. GUWAHATI.
HYDERABAD. JAIPUR. KANPUR. LUCKNOW. NAGPUR.
PATNA. PUNE. THIRUVANANTHAPURAM.

AMENDMENT NO. 1 JUNE 1998
TO
IS 6533 (PART 2) : 1989 CODE OF PRACTICE FOR
DESIGN AND CONSTRUCTION OF STEEL CHIMNEY

PART 2 STRUCTURAL ASPECT

(First Revision)

(Page 5, Table 2) — Substitute the following set of figures for the existing:

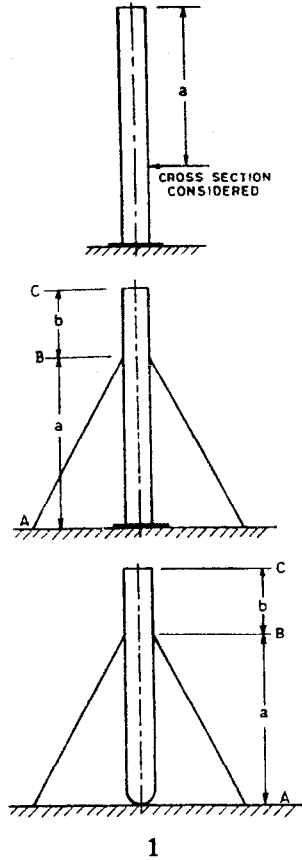

Amend No. 1 to IS 6533 (Part 2) : 1989

(Page 12, clause 10.10.1.2, line 2) — Substitute '300 mm' for '3 000 mm'.

(Page 12, clause 10.10.1.2, line 3) — Substitute '3 000 mm' for '300 mm'.

(Page 17, clause A-3) — Substitute 'm' for 'mm' in the definition given for D_t under formula (1).

(Page 17, clause A-4) — Substitute ' $C_y q_{cr} d_z h_z$ ' for the existing in the definition given in the fifth line for $F_{ei}(z)$ under formula (2).

(Page 17, clause A-4) — Substitute ' $\frac{V_{cr}^2}{16}$ ' for the existing in the definition given for q_{cr} in the third line under formula (2).

(Page 18, clause A-6) — Substitute 'shape' for 'sape' in the definition given for C.

(Page 20, Annex C) — Substitute the following formula for the existing against B:

$$B = 270 \frac{t}{D} \left(1 - 67 \frac{t}{D} \right), \text{ if } \frac{D}{t} > 130$$

(CED 7)