

इंटरनेट

मानक

Disclosure to Promote the Right To Information

Whereas the Parliament of India has set out to provide a practical regime of right to information for citizens to secure access to information under the control of public authorities, in order to promote transparency and accountability in the working of every public authority, and whereas the attached publication of the Bureau of Indian Standards is of particular interest to the public, particularly disadvantaged communities and those engaged in the pursuit of education and knowledge, the attached public safety standard is made available to promote the timely dissemination of this information in an accurate manner to the public.

“जानने का अधिकार, जीने का अधिकार”

Mazdoor Kisan Shakti Sangathan

“The Right to Information, The Right to Live”

“पुराने को छोड़ नये के तरफ”

Jawaharlal Nehru

“Step Out From the Old to the New”

IS 1795 (1982): Pillar Taps for Water Supply Purposes [CED
3: Sanitary Appliances and Water Fittings]



“ज्ञान से एक नये भारत का निर्माण”

Satyanarayan Gangaram Pitroda

“Invent a New India Using Knowledge”



“ज्ञान एक ऐसा खजाना है जो कभी चुराया नहीं जा सकता है”

Bhartrhari—Nitiśatakam

“Knowledge is such a treasure which cannot be stolen”

BLANK PAGE



Indian Standard

SPECIFICATION FOR

PILLAR TAPS FOR WATER SUPPLY PURPOSES

(*Second Revision*)

UDC 621.646.72 : 696.117

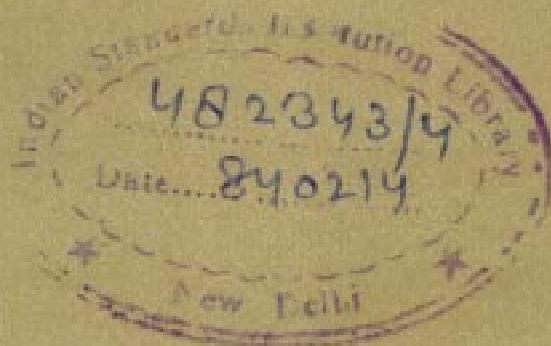

© Copyright 1983

INDIAN STANDARDS INSTITUTION
MANAK BHAVAN, 9 BAHADUR SHAH ZAFAR MARG
NEW DELHI 110002

Indian Standard

SPECIFICATION FOR PILLAR TAPS FOR WATER SUPPLY PURPOSES (*Second Revision*)

Sanitary Appliances and Water Fittings Sectional Committee, BDC 3

Chairman

SHRI K. D. MULEKAR

Representing

Municipal Corporation of Greater Bombay, Bombay

Members

DEPUTY HYDRAULIC ENGINEER (*Alternate to*

SHRI K. D. MULEKAR)

ADVISER (PHE)

Central Public Health & Environmental Engineering Organization (Ministry of Works & Housing), New Delhi

DEPUTY ADVISER (PHE) (*Alternate to*

SHRI M. K. BASU

Central Glass & Ceramic Research Institute (CSIR), Calcutta

SHRI D. S. CHABHAL

Directorate General of Technical Development, New Delhi

SHRI T. RAMASUBRAMANIAN (*Alternate to*

SHRI S. P. CHAKRABARTI

Central Building Research Institute (CSIR), Roorkee

SHRI S. K. SHARMA (*Alternate to*

CHIEF ENGINEER

Public Health Engineering Department, Government of Kerala, Trivendrum

SHRI K. RAMACHANDRAN (*Alternate to*

CHIEF ENGINEER

UP Jal Nigam, Lucknow

SUPERINTENDING ENGINEER (*Alternate to*

✓ SHRI J. D' CRUZ

Delhi Municipal Corporation, Delhi

ADDL CHIEF ENGINEER (*Alternate to*

DIRECTOR

Bombay Potteries & Tiles Ltd, Bombay

SHRI B. R. N. GUPTA

Engineer-in-Chief's Branch, Army Headquarters

SHRI K. V. KRISHNAMURTHY (*Alternate to*

SHRI P. JAGANATH RAO

EID-Parry Ltd, Ranipet

SHRI M. MOOSA SULAIMAN (*Alternate to*

SHRI S. R. KSHIRSAGAR

National Environmental Engineering Research Institute (CSIR), Nagpur

SHRI R. C. REDDY (*Alternate to*

SHRI K. LAKASHMINARAYANAN

Hindustan Shipyard Ltd, Visakhapatnam

SHRI A. SHARIF (*Alternate to*

(*Continued on page 2*)

© Copyright 1983

INDIAN STANDARDS INSTITUTION

This publication is protected under the *Indian Copyright Act* (XIV of 1957) and reproduction in whole or in part by any means except with written permission of the publisher shall be deemed to be an infringement of copyright under the said Act.

(Continued from page 1)

<i>Members</i>	<i>Representing</i>
SHRI E. K. RAMACHANDRAN	National Test House, Calcutta
SHRI S. K. BANERJEE (<i>Alternate</i>)	
SHRI RANJIT SINGH	Ministry of Railways (Railway Board)
DR A. V. R. RAO	National Buildings Organization, New Delhi
SHRI J. SENGUPTA (<i>Alternate</i>)	
SHRI R. K. SOMANY	Hindustan Sanitaryware & Industries Ltd, Bahadurgarh (Haryana)
SHRI R. K. SUNDRAM	Central Public Works Department, New Delhi
SURVEYOR OF WORKS I (NDZ)	(<i>Alternate</i>)
SHRI T. N. UBOVEJA	Directorate General of Supplies & Disposals, New Delhi
SHRI G. RAMAN,	Director General, ISI (<i>Ex-officio Member</i>)
Director (Civ Engg)	

Secretary

SHRI C. K. BEBARTA
Senior Deputy Director (Civ Engg), ISI

Domestic and Municipal Water Fittings Subcommittee, BDC 3 : 2

Convener

SHRI K. D. MULEKAR Municipal Corporation of Greater Bombay, Bombay

Members

DEPUTY HYDRAULIC ENGINEER (<i>Alternate</i> to	
SHRI K. D. MULEKAR)	
SHRI YASH RAJ AGGARWAL	Goverdhan Das P. A., Calcutta
SHRI JOGINDER RAJ AGGARWAL (<i>Alternate</i>)	
CHIEF ENGINEER	Bangalore Water Supply Sewerage Board, Bangalore
CHIEF ENGINEER	Tamil Nadu Water Supply & Drainage Board, Madras
CHIEF ENGINEER	UP Jal Nigam, Lucknow
SUPERINTENDING ENGINEER (<i>Alternate</i>)	
DIRECTOR	Maharashtra Engineering Research Institute, Nasik
RESEARCH OFFICER (<i>Alternate</i>)	
SHRI J. D.' CRUZ	Municipal Corporation of Delhi, Delhi
SHRI S. A. SWAMY (<i>Alternate</i>)	
SHRI B. R. N. GUPTA	Engineer-in-Chief's Branch, Army Headquarters
SHRI K. V. KRISHNAMURTHY (<i>Alternate</i>)	
SHRI M. K. JAIN	Hind Trading & Manufacturing Co Ltd, New Delhi
SHRI K. K. JAIN (<i>Alternate</i>)	
SHRI S. R. KSHIRSAGAR	National Environmental Engineering Research Institute, Nagpur
SHRI A. W. DESHPANDE (<i>Alternate</i>)	
SHRI G. A. LUHAR	Bombay Metal and Alloy Manufacturing Co Pvt Ltd, Bombay
SHRI K. RAMACHANDRAN	Public Health Engineering Department, Government of Kerala, Trivandrum
SHRI RANJIT SINGH	Ministry of Railways, New Delhi
SHRI D. K. SEHGAL	Leader Engineering Works, Jullundur
SHRI B. B. SIKKA (<i>Alternate</i>)	
SHRI R. K. SOMANY	Hindustan Sanitaryware & Industries Ltd, Bahadurgarh
SHRI T. N. UBOVEJA	Directorate General of Supplies & Disposals, New Delhi

Indian Standard
SPECIFICATION FOR
PILLAR TAPS FOR WATER SUPPLY PURPOSES
(*Second Revision*)

0. FOREWORD

0.1 This Indian Standard (Second Revision) was adopted by the Indian Standards Institution on 30 November 1982, after the draft finalized by the Sanitary Appliances and Water Fittings Sectional Committee had been approved by the Civil Engineering Division Council.

0.2 This standard which, was first published in 1961, gave guidance to manufacturers for producing pillar taps of high quality and interchangeability suitable for wash basins. In the first revision in 1974, the requirements of 25 mm size pillar taps were deleted as they are not in common use. This revision of the standard has been taken up to incorporate further improvements found necessary in the light of the usage of the same since its publication. These include modifications relating to the requirements of material and dimensions of various components of pillar tap.

0.3 For the purpose of deciding whether a particular requirement of this standard is complied with, the final value, observed or calculated, expressing the result of a test or analysis, shall be rounded off in accordance with IS : 2-1960*. The number of significant places retained in the rounded off value should be the same as that of the specified value in this standard.

1. SCOPE

1.1 This standard lays down requirements regarding material, manufacture and workmanship, construction, finish and testing of pillar taps.

*Rules for rounding off numerical values (revised).

2. TERMINOLOGY

2.0 For the purpose of this standard, the following definition shall apply.

2.1 Pillar Tap — It is a draw-off tap with a vertical inlet and an uptilted or a horizontal free outlet.

3. NOMINAL SIZES

3.1 The nominal sizes of the pillar taps shall be 15 mm and 20 mm.

3.1.1 The nominal size of the pillar taps shall be designated by the nominal bore of the pipe outlet to which the tap is to be fitted.

4. MATERIAL

4.1 Materials used for manufacture of different components of pillar taps shall conform to the requirements given in Table 1.

TABLE 1 MATERIALS FOR COMPONENT PARTS OF PILLAR TAPS

Sl. No.	COMPONENT	MATERIAL	CONFORMING TO INDIAN STANDARD
(1)	(2)	(3)	(4)
i)	Body, body components, capstan head and washer plate	a) Cast brass	Grade 3 of IS : 292-1961* or DCB 2 of IS : 1264-1981†
		b) Leaded tin bronze	Grade LTB 2 of IS : 318-1981‡
ii)	Spindle, gland, washer plate and nut	a) Brass rod (extruded or rolled)	Type I half hard of IS : 319-1974§
		b) Brass	IS : 3488-1980

*Specification for brass ingots and castings (*revised*).

†Specification for brass gravity die castings (ingots and castings) (*second revision*).

‡Specification for leaded tin bronze ingots and castings (*second revision*).

§Specification for free-cutting brass bars, rods and sections (*third revision*).

||Specification for brass bars, rods and sections suitable for forging (*first revision*).

4.2 The material for washer for use in pillar taps shall conform to the requirements specified in IS : 4346-1982*.

5. MANUFACTURE AND WORKMANSHIP

5.1 Castings shall in all respects be sound and free from laps, blow holes and pitting. External and internal surfaces shall be clean, smooth and free from sand. They shall be neatly dressed and no casting shall be burned, plugged, stopped or patched.

*Specification for washers for water taps for cold water services (*first revision*).

5.2 The body, bonnet, spindle and other parts shall be machined true, so that when assembled, the parts shall be axial, parallel and cylindrical with surfaces smoothly finished.

6. CONSTRUCTION

6.1 Illustration of a typical pillar tap is given in Fig. 1.

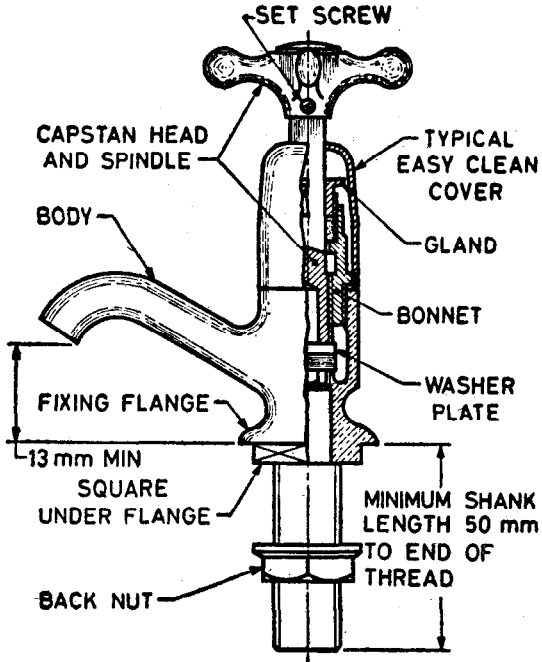

NOTE — The shape of the component parts is only illustrative but the dimensions and minimum requirements where specified are binding.

FIG. 1 PILLAR TAP

6.2 Body and Easy-Clean Cover

6.2.1 The area of water-way throughout the body of the pillar tap shall not be less than the area of a circle of diameter equal to the bore of the seating of the pillar tap.

6.2.2 The seating of the pillar tap shall be integral with the body. The edges shall be rounded to avoid cutting of washer.

6.2.3 The thickness of walls not threaded, and of metal supporting the seating shall be such that deformation shall not result when the spindle is screwed hard down.

6.2.4 Pillar tap shall have screwed shanks not less than 50 mm long from the underside of the flange and shall be provided with back nut. There shall be a locating arrangement under the flange, such as a square as illustrated in Fig. 1 or alternatively four ribs or lugs to prevent the tap from rotating in the ware after attachment.

6.2.5 The outlet nose of the pillar tap shall be higher than the level of the underside of the fixing flange by 13 mm, *Min* (see Fig. 1). The outlet nose shall be uplifted or horizontal as specified by the purchaser.

6.2.6 Easy-clean cover shall be of circular cross section and shall be of sufficient thickness to give the required mechanical strength, the minimum thickness being not less than 1 mm for forgings and 0.8 mm for sheet-metal pressings.

6.2.7 Easy-clean covers shall be threaded for attachment to the bonnet flange.

6.2.8 Dimensions of body and back nut shall conform to Tables 2 and 3 respectively.

6.3 Bonnet and Gland

6.3.1 The dimensions of bonnet and gland shall be as given in Table 4. The internal thread in the bonnet shall be so formed that when the spindle is screwed into the bonnet to its fully open position, the end of the spindle projects beyond the face of the bonnet at least by 0.7 mm. A recess shall be formed at the top of the thread equal in depth to the depth of the thread and in length not greater than the dimension *D* specified in Table 4.

6.3.2 Hexagonal shoulder shall be provided on the bonnet.

6.3.3 To facilitate the removal of the bonnet, it shall be possible, when the tap is fully open to raise the easy-clean cover high enough to expose the full depth of the hexagon on the head.

6.3.4 The gland or stuffing box shall be packed with a suitable asbestos packing or other equally efficient packing material suitable for cold and hot water. A suitable washer may be fitted in the bottom of the gland or stuffing box, but this may be omitted if the packing is in the form of a moulded composition packing ring.

TABLE 2 DIMENSIONS OF BODY

(Clause 6.2.8)

All dimensions in millimetres.

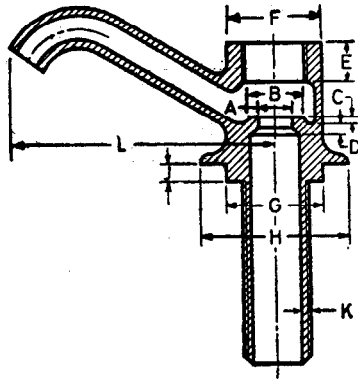

Sl. No.	PARTICULAR	DIMENSION			
		15-mm Size		20-mm Size	
(1)	(2)	Max (3)	Min (4)	Max (5)	Min (6)
	i) Bore of seating, <i>A</i>	12.9	12.6	19.2	18.9
	ii) Outside diameter of seating, <i>B</i>	—	17.9	—	24.2
	iii) Height of seating, <i>C</i>	—	1.6	—	1.6
	iv) Thickness of walls, not threaded and metal supporting the seat, <i>D</i>	—	2.0	—	2.0
	v) Length of internal thread on body, <i>E</i>	—	11.1	—	12.7
	vi) Outside diameter of body at face, <i>F</i>	—	30.0	—	39.0
	vii) Size over flats of square under flange, <i>G</i>	25.4	—	31.7	—
	viii) Diameter of flange, <i>H</i>	—	44.4	—	50.8
	ix) Depth of square under flange, <i>J</i>	6.0	5.0	6.0	5.0
	x) Thickness of wall of externally threaded (minor diameter to bore), <i>K</i>	—	2.3	—	2.3
	xi) Horizontal length of nose from centre of inlet to the outer tip of the outlet, <i>L</i>	—	100.0	—	100.0

NOTE — For dimension *D*, the minimum may be reduced by 0.5 mm in the case of outlets only.

TABLE 3 DIMENSIONS OF BACK NUT

(Clause 6.2.8)

All dimensions in millimetres.

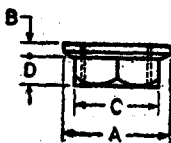

Sl No.	PARTICULAR	DIMENSION	
		15-mm Size, <i>Min</i>	20-mm Size, <i>Min</i>
(1)	(2)	(3)	(4)
	i) Diameter of collar, <i>A</i>	38	44
	ii) Thickness of collar, <i>B</i>	2.5	3.0
	iii) Size of hexagon across flats, <i>C</i>	26.5	31.5
	iv) Height of hexagon, <i>D</i>	7.0	7.0

6.4 Capstan Head and Spindle

6.4.1 Capstan head shall be fitted on squared end of the spindle and shall not be screwed on the spindle and suitably secured. Hot and cold water taps shall be suitably indicated on the top of the capstan using fire red and blue colours respectively.

6.4.2 The capstan heads shall be a close fit on the spindle (without shake) and shall be fixed to the spindle by a set screw so that the capstan head can readily be removed for repacking the gland.

6.4.3 The distance between the underside of the capstan head and the top of the easy-clear cover shall be measured when the tap, with washer fixed, is closed.

6.4.4 The length of the spindle thread shall be such that when the washer plate is resting on the seating without any washer, a length of the thread equal to not less than three-fourths of the external diameter of the threaded portion of the spindle will be in full engagement with the internal thread of the bonnet.

6.4.5 Dimensions of capstan heads and spindles shall conform to Table 5.

TABLE 4 DIMENSIONS OF BONNET AND GLAND

(Clause 6.3.1)

All dimensions in millimetres.

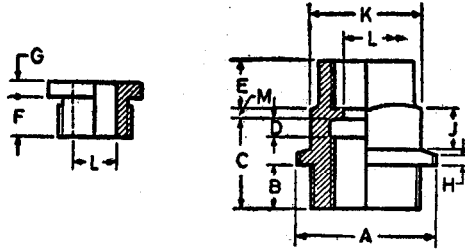

Sl No.	PARTICULAR	DIMENSION			
		15-mm Size		20-mm Size	
		Max	Min	Max	Min
(1)	(2)	(3)	(4)	(5)	(6)
	i) Size of external threads on bonnet flange, <i>A</i>	M 30 × 1		M 39 × 1.5	
	ii) Length of external thread on bonnet, <i>B</i>	—	11.1	—	12.7
	iii) Length of internal thread, <i>C</i> for spindle including 'recess'	—	20.0	—	21.5
	iv) Axial length of recess, <i>D</i>	4.2	—	4.6	—
	v) Axial length of stuffing box, <i>E</i> (minimum length of thread)	—	9.5	—	11.1
	vi) Length of external thread on gland, <i>F</i> , including runout	—	7.6	—	8.8
	vii) Thickness of gland flange, <i>G</i>	—	2.8	—	3.2
	viii) Thickness of bonnet flange, <i>H</i>	—	3.5	—	4.5
	ix) Axial length of hexagon, <i>J</i>	—	9.5	—	9.5
	x) Size of hexagon over flats, <i>K</i>	—	21.5	—	23.5
	xi) Diameter of hole through bonnet and gland for spindle, <i>L</i>	9.9	9.6	11.5	11.2
	xii) Axial length of collar, bottom of stuffing box, <i>M</i>	—	2.4	—	2.8

TABLE 5 DIMENSIONS OF CAPSTAN HEADS, SPINDLES AND WASHER PLATES
(Clauses 6.4.5 and 6.5.7)

All dimensions in millimetres.

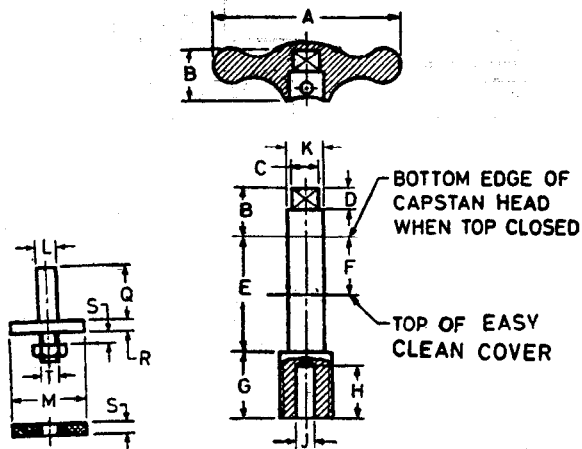

Sl No.	PARTICULAR	DIMENSION			
		15-mm Size		20-mm Size	
		Max	Min	Max	Min
(1)	(2)	(3)	(4)	(5)	(6)
i)	Length of round capstan head, <i>A</i>	—	54.0	—	60.0
ii)	Length at centre line of boss of capstan head, <i>B</i>	—	14.0	—	16.0
iii)	Size across flats of square end of spindle, <i>C</i>	—	6.7	—	7.9
iv)	Length of square end of spindle, <i>D</i>	—	4.7	—	6.3
v)	Length under capstan head of plain portion of spindle, <i>E</i>	—	35.5	—	40.5
vi)	Distance (when closed) from underside of capstan head to top of easy-clean cover	—	7.5	—	10.0
vii)	Length of external thread on spindle, <i>G</i>	—	20.8	—	22.4

(Continued)

TABLE 5 DIMENSIONS OF CAPSTAN HEADS, SPINDLES AND WASHER PLATES — Contd.

All dimensions in millimetres.

Sl. No.	PARTICULAR	DIMENSION			
		15-mm SIZE		20-mm SIZE	
		Max	Min	Max	Min
(1)	(2)	(3)	(4)	(5)	(6)
viii)	Depth of parallel hole in spindle (for steam of washer plate), <i>H</i>	18.8	18.0	20.4	19.5
ix)	Diameter of parallel hole in spindle (for stem of washer plate), <i>J</i>	6.0	5.8	6.8	6.6
x)	Diameter of plain portion of spindle, <i>K</i>	—	9.4	—	11.0
xi)	Diameter of steam washer plate, <i>L</i>	5.7	5.6	6.5	6.4
xii)	Outside diameter of washer plate (flat type), <i>M</i>	—	19.0	—	23.4
xiii)	Length of washer plate stem, <i>Q</i>	16.3	15.6	17.9	17.1
xiv)	Thickness of washer plate, <i>R</i>	—	3.2	—	4.0
xv)	Thickness of washer (when new), <i>S</i>	—	4.0	—	4.0
xvi)	Screw thread of stud and nut (for fixing washer) <i>T</i> and for inside screw thread of washer plate where separately made	M 5 × 0.8		M 6 × 1	

6.5 Washer Plate and Washer

6.5.1 The washer plate with its stem shall be either made in one piece from cast brass or in two pieces from extruded brass rods and shall be true all over, specially on the face on which the washer will be seated. If the washer plate is a casting, it shall be machined all over.

6.5.2 The washer plate in cold water pillar tap shall be free to rotate and slide in the spindle hole; and in hot water pillar taps, it shall be free to rotate in the spindle hole and shall be so secured as to lift with the spindle.

6.5.3 The top of the washer plate shall be clear of the bottom of the bonnet when the tap is fully open.

6.5.4 Washer plates shall have a stud for attaching the washer. The stud shall be threaded and provided with a nut.

6.5.5 Replaceable washers conforming to the requirements of IS : 4346-1982* shall always be provided for cold and hot water taps and shall be made of the materials specified in IS : 4346-1982*.

6.5.6 When the washer is fitted with a retaining ring, the internal diameter of the ring shall be greater than the external diameter of the seating to which it is fitted and the thickness of the washer shall not be less than 5 mm.

6.5.7 Dimensions of washer plate and washer shall conform to Table 5.

6.6 Screw Threads

6.6.1 *General* — All the screw threads other than inlet connection shall conform to the ISO metric screw threads given in IS : 4218†. The inlet connection shall have parallel (external) pipe threads and back nut shall have parallel (internal) threads. The pipe threads shall conform to IS : 2643‡.

6.6.2 The screw threads on body, bonnet, gland, spindle and stuffing box shall conform to Table 6.

6.7 Anti-splash Device — Pillar tap shall, when required by the purchaser, be fitted with an anti-splash device. A typical example of such a device is a corrugated sleeve formed from phosphor bronze strip 10 mm wide and 0.45 mm thick of a composition complying grade I, II or III of IS : 7814-1975§ and corrugated to a depth of 3 mm, cut to the appropriate length and bent to form a ring inside the outlet nose.

6.8 The inlet and outlet of pillar taps shall have squared up faces at the end to facilitate testing under pressure.

*Specification for washers for water taps for cold water services (*first revision*).

†ISO metric screw threads:

Part I Basic and design profiles (*first revision*).

Part II Pitch diameter combinations (*first revision*).

Part III Basic dimensions for design profiles (*first revision*).

Part IV Tolerancing system (*first revision*).

Part V Tolerance

Part VI Limits of sizes for commercial bolts and nuts (diameter range 1 to 39 mm) (*first revision*).

‡Dimensions for pipe threads for fastening purposes:

Part I Basic profile and dimensions

Part II Tolerances (*first revision*).

Part III Limits of sizes (*first revision*).

§Specification for phosphor bronze sheet, strip and foil.

TABLE 6 DIMENSIONS OF SCREW THREADS FOR PILLAR TAP COMPONENTS

(Clause 6.6.2)

NOMINAL SIZE OF PILLAR TAP	DESIGNATION OF SCREW THREADS*					
	Body, Internal for Engagement with Bonnet Thread, External	Bonnet, External for Engagement with Body Thread, Internal	Bonnet, Internal for Engagement with Spindle Thread, External	Stuffing Box, Internal for Engagement with Gland Thread, External	Gland, External for engagement with Stuffing Box Thread, Internal	Spindle, External for engagement with Bonnet Thread, Internal
(1)	(2)	(3)	(4)	(5)	(6)	(7)
15 mm	M 24 × 1.5 m	M 24 × 1.5 m	M 14 × 2 m	M 16 × 1.5 f	M 16 × 1.5 m	M 14 × 2 c
20 mm	M 30 × 1.5 m	M 30 × 1.5 m	M 16 × 2 m	M 18 × 1.5 f	M 18 × 1.5 m	M 16 × 2 c

NOTE 1 — For dimensions and tolerances for screw threads, see IS : 4218*.

NOTE 2 — All external and internal threads shall have bolt and nut tolerances respectively.

NOTE 3 — Abbreviations :

m = Medium tolerances

f = Fine tolerances

c = Coarse tolerances

*ISO metric screw threads:

Part I Basic and design profiles (*first revision*).

Part II Pitch diameter combinations (*first revision*).

Part III Basic dimensions for design profiles (*first revision*).

Part IV Tolerancing system (*first revision*).

Part V Tolerance

Part VI Limits of sizes for commercial bolts and nuts (diameter range 1 to 39 mm) (*first revision*).

7. MINIMUM FINISHED MASS

7.1 The minimum finished mass of 15-mm and 20-mm size pillar taps shall be 650 g and 1 175 g respectively.

8. FINISH

8.1 Pillar taps shall be nickel-chromium plated and thickness of coating shall not be less than service Grade No. 2 of IS : 4827-1968*. The plating shall be capable of taking high polish which will not easily tarnish or scale.

8.1.1 Before plating the pillar tap, the washer plate and washer shall be removed from the fitting, and the gland packing shall, so far as practicable, be protected from the plating solution.

9. SAMPLING AND CRITERIA FOR CONFORMITY

9.1 The sampling procedure to be adopted and the criteria for conformity shall be as given in Appendix A.

10. TESTING

10.1 Every pillar tap, complete with its component parts shall withstand an internally applied hydraulic pressure of 2 MPa (20 kgf/cm²), maintained for a period of 2 minutes, during which period, it shall neither leak nor sweat.

11. MARKING

11.1 Every pillar tap shall be legibly marked with the following information:

- a) Manufacturer's name or trade-mark, and
- b) Nominal size.

11.1.1 The pillar tap may also be marked with the ISI Certification Mark.

NOTE — The use of the ISI Certification Mark is governed by the provisions of the Indian Standards Institution (Certification Marks) Act and the Rules and Regulations made thereunder. The ISI Mark on products covered by an Indian Standard conveys the assurance that they have been produced to comply with the requirements of that standard under a well-defined system of inspection, testing and quality control which is devised and supervised by ISI and operated by the producer. ISI marked products are also continuously checked by ISI for conformity to that standard as a further safeguard. Details of conditions under which a licence for the use of the ISI Certification Mark may be granted to manufacturers or processors, may be obtained from the Indian Standards Institution.

*Specification for electroplated coatings of nickel and chromium on copper and copper alloys.

APPENDIX A

(Clause 9.1)

SAMPLING AND CRITERIA FOR CONFORMITY

A-1. SAMPLING

A-1.1 Lot — In any consignment all the pillar taps made of the same material and of the same nominal size, from the same batch of manufacture shall be grouped together to constitute a lot.

A-1.1.1 Samples shall be selected and tested from each lot separately to determine conformity or otherwise of the lot to the requirements of this specification.

A-1.2 The number of taps to be selected from a lot shall depend upon the size of the lot and shall be in accordance with col 1 and 2 of Table 7.

TABLE 7 SAMPLE SIZE AND CRITERIA FOR CONFORMITY

(Clauses A-1.2, A-2.1, A-2.1.1 and A-3.2)

LOT SIZE	SAMPLE SIZE	PERMISSIBLE NUMBER OF DEFECTIVE	SUB-SAMPLE SIZE
(1)	(2)	(3)	(4)
Up to 150	8	0	3
151 to 300	13	0	5
301 to 500	20	1	8
501 to 1 000	32	2	13
1 001 to 3 000	50	3	20
3 001 and above	80	5	32

A-1.3 The taps for the sample shall be selected at random from the lot. For ensuring randomness of selection, procedures given in IS : 4905-1968*, may be followed.

A-2. NUMBER OF TESTS

A-2.1 All the taps in the sample selected in accordance with col 2 of Table 7 shall be examined for material, workmanship, construction, finish, dimensions and minimum finished mass.

*Methods for random sampling.

A-2.1.1 The number of taps to be tested for hydraulic pressure test shall be in accordance with col 4 of Table 7. This sub-sample shall be selected from those taps which have been already examined under **A-2.1** and have been found conforming to the requirements of this standard listed in **A-2.1**.

A-3. CRITERIA FOR CONFORMITY

A-3.1 The lot shall be considered conforming to the requirements of this specification if the conditions in **A-3.2** and **A-3.3** are satisfied.

A-3.2 The number of taps failing to satisfy the requirements for one or more of the characteristics mentioned in **A-2.1** shall not exceed the corresponding number given in col 3 of Table 7.

A-3.3 No tap in the sub-sample shall fail in hydraulic test (*see 10.1*).