

इंटरनेट

मानक

### Disclosure to Promote the Right To Information

Whereas the Parliament of India has set out to provide a practical regime of right to information for citizens to secure access to information under the control of public authorities, in order to promote transparency and accountability in the working of every public authority, and whereas the attached publication of the Bureau of Indian Standards is of particular interest to the public, particularly disadvantaged communities and those engaged in the pursuit of education and knowledge, the attached public safety standard is made available to promote the timely dissemination of this information in an accurate manner to the public.

“जानने का अधिकार, जीने का अधिकार”

Mazdoor Kisan Shakti Sangathan

“The Right to Information, The Right to Live”

“पुराने को छोड़ नये के तरफ”

Jawaharlal Nehru

“Step Out From the Old to the New”

IS 15778 (2007): Chlorinated polyvinyl chloride (CPVC) pipes for potabvle hot and cold water distribution supplies - [CED 50: Civil Engineering]



“ज्ञान से एक नये भारत का निर्माण”

Satyanarayan Gangaram Pitroda

“Invent a New India Using Knowledge”



“ज्ञान एक ऐसा खजाना है जो कभी चुराया नहीं जा सकता है”

Bhartrhari—Nitiśatakam

“Knowledge is such a treasure which cannot be stolen”



भारतीय मानक

तप्त और अतप्त पेय जल वितरण व्यवस्था के लिए क्लोरीनकृत  
पॉलीविनायल क्लोराइड (सीपीवीसी) पाइप — विशिष्टि

*Indian Standard*

CHLORINATED POLYVINYL CHLORIDE (CPVC) PIPES  
FOR POTABLE HOT AND COLD WATER  
DISTRIBUTION SUPPLIES — SPECIFICATION

ICS 23.040.20; 91.140.60

©BIS2007

**BUREAU OF INDIAN STANDARDS**  
MANAK BHAVAN, 9 BAHADUR SHAH ZAFAR MARG  
NEW DELHI 110002

## FOREWORD

This Indian Standard was adopted by the Bureau of Indian Standards, after the draft finalized by the Plastic Piping Systems Sectional Committee had been approved by the Civil Engineering Division Council.

In the formulation of this standard, considerable assistance has been derived from ISO 15877-1 : 2003 'Plastic piping system for hot and cold water installation — Chlorinated polyvinyl chloride (PVC - C): Part 1 General' and ISO 15877-2 : 2003 'Plastic piping system for hot and cold water installation — Chlorinated polyvinyl chloride (PVC-C) : Part 2 Pipes'. The sizes of pipes however have been kept as per manufacturing practices being followed in India and have been derived from ASTM F 442M - 99 'Standard specification for chlorinated polyvinyl chloride (CPVC) plastic pipe (SDR-PR)' and ASTM D 2846M - 99 'Standard specification for chlorinated polyvinyl chloride (CPVC) plastic hot and cold water distribution systems'.

This standard does not purport to address all the safety problems associated with its use. It is the responsibility of the users of this standard to establish appropriate safety and health practices and determine the applicability of regulatory safety and health practices and determine the applicability of regulatory limitation prior to use.

This standard also provides recommendatory information at Annex E regarding storage and guidelines for installation.

For the purpose of deciding whether a particular requirement of this standard is complied with the final value, observed or calculated, expressing the result of a test or analysis, shall be rounded off in accordance with IS 2 : 1960 'Rules for rounding off numerical values (*revised*)'. The number of significant places retained in the rounded off value should be the same as that of the specified value in this standard.

## *Indian Standard*

# CHLORINATED POLYVINYL CHLORIDE (CPVC) PIPES FOR POTABLE HOT AND COLD WATER DISTRIBUTION SUPPLIES — SPECIFICATION

## 1 SCOPE

This standard specifies requirements, test methods and methods of marking for chlorinated polyvinyl chloride plastic pipes for hot and cold water distribution supplies, made in three standard dimension ratios and intended for water service up to and including 82°C.

## 2 REFERENCES

The standards listed in Annex A contain provisions, which through reference in this text constitute provisions of this standard. At the time of publication the editions indicated were valid. All standards are subject to revision and parties to agreements based on this standard are encouraged to investigate the possibility of applying the most recent editions of the standards indicated in Annex A.

## 3 TERMINOLOGY

For the purpose of this standard, the following definitions shall apply.

**3.1 Nominal Size (DN)** — The numerical designation for the size of a pipe, other than a pipe designated by thread size, which is a convenient round number approximately equal to the manufacturing dimensions in millimetres.

**3.2 Nominal Outside Diameter ( $d_n$ )** — The specified outside diameter, in millimetres, assigned to a nominal size.

**3.3 Outside Diameter at any Point ( $d_e$ )** — The value of the measurement of the outside diameter of a pipe through its cross-section at any point of the pipe rounded off to the nearest 0.1 mm.

**3.4 Mean Outside Diameter ( $d_{em}$ )** — The quotient of the outer circumference of a pipe and 3.142 ( $\pi$ ) in any cross-section, rounded off to the nearest 0.1 mm.

**3.5 Minimum Mean Outside Diameter ( $d_{em,Min}$ )** — The minimum value of the mean outside diameter specified for a given nominal size.

**3.6 Maximum Mean Outside Diameter ( $d_{em,Max}$ )** — The maximum value of the mean outside diameter specified for a given nominal size.

**3.7 Out-of-Roundness (Ovality)** — The difference between the measured maximum and measured minimum

outside diameter at the same cross-section of the pipe.

**3.8 Nominal Wall Thickness ( $e_n$ )** — The numerical designation of the wall thickness of a component, which is a convenient round number, approximately equal to the manufacturing dimension in millimetres.

**3.9 Wall Thickness at any Point ( $e$ )** — The value of the measurement of the wall thickness at any point around the circumference of pipe, rounded off to the nearest 0.1 mm.

**3.10 Minimum Wall Thickness at any Point ( $e_{Min}$ )** — The minimum value for the wall thickness at any point around the circumference of a pipe, rounded off to the nearest 0.1 mm.

**3.11 Maximum Wall Thickness at any Point ( $e_{Max}$ )** — The maximum value for the wall thickness at any point around the circumference of a pipe, rounded off to the nearest 0.1 mm.

**3.12 Mean Wall Thickness ( $e_m$ )** — The arithmetic mean of at least four measurements regularly spaced around the circumference and in the same cross-section of a pipe, including the measured minimum and measured maximum values of the wall thickness in that cross-section and rounded off to the nearest 0.1 mm.

**3.13 Tolerance** — The permitted variations of the specified value of a quantity, expressed as the difference between the permitted maximum and the permitted minimum values.

**3.14 Working Pressure (PN)** — The numerical designation of a pipe related to the mechanical characteristics of that pipe used for reference purposes. For plastics piping systems, it corresponds to the allowable operating pressure in MPa, conveying water at 27°C.

**3.15 Allowable Operating Pressure (PFA)** — The maximum hydrostatic pressure excluding surge, which is allowed in continuous use with water within the temperature range concerned. It is calculated using the following equation:

$$PFA = fT \times (PN)$$

where

$fT$  = de-rating factor depending on water temperature, and

$PN$  = working pressure.

**3.16 Hydrostatic Stress ( $\sigma$ )** — The stress induced in the wall of a pipe when a pressure is applied using water as a medium. The hydrostatic stress is related to the applied pressure,  $P$ , the wall thickness at any point,  $e$ , and the mean outside diameter,  $d_{em}$ , of a pipe and calculated using the following equation:

$$\sigma = P(d_{em} - e) / 2e$$

**3.17 Long Term Hydrostatic Stress** — The constant hydrostatic stress, which is maintained during a sustained period of time.

**3.18 Malfunction Temperature ( $T_{mal}$ )** — Highest temperature that can be reached when the control limits are exceeded.

### 3.19 Tests

**3.19.1 Type Tests** — Tests carried out whenever a change is made in the composition or in the size/series in order to establish the suitability and the performance capability of the pipe.

**3.19.2 Acceptance Tests** — Tests carried out on samples taken from a lot for the purpose of acceptance of the lot.

**3.20 Virgin Material** — Material in such form as granules or powder that has not been subjected to use or processing other than that required for its manufacture and to which no re-processible or recyclable material(s) have been added.

**3.21 Own Rework Material** — Material prepared from rejected unused pipes, including the trimmings from the production of pipes, which will be reprocessed in a manufacturer's plant by a process such as extrusion and for which the complete formulation is known.

**3.22 Standard Thermoplastic Pipe Dimension Ratio (SDR)** — The standard thermoplastic pipe dimension ratio (SDR) is the ratio of pipe diameter to wall thickness.

## 4 NOTATION

The following notation (symbols) shall apply in this standard:

$d_n$	=	nominal outside diameter
$d_e$	=	outside diameter at any point
$d_{em}$	=	mean outside diameter
$d_{em,Max}$	=	maximum mean outside diameter
$d_{em,Min}$	=	minimum mean outside diameter
$DN$	=	nominal size
$e$	=	wall thickness at any point
$e_m$	=	mean wall thickness
$e_{Max}$	=	maximum wall thickness at any point

$e_{Min}$	=	minimum wall thickness at any point
$e_n$	=	nominal wall thickness
$L_o$	=	overall length of the pipe
$L_e$	=	effective length of the pipe
$PN$	=	nominal pressure (working pressure)
$fT$	=	de-rating factor for water temperatures
$\sigma$	=	hydrostatic stress

## 5 CLASSIFICATION OF PIPES

The pipes shall be classified by pressure rating (working pressure) at 27°C and 82°C (see Table 1).

**Table 1 Working Pressure for Pipes**

All values are in MPa.				
Sl No.	Pressure Class	Working Pressure at		
		SDR	27°C	82°C
(1)	(2)	(3)	(4)	(5)
i)	1	11	2.76	0.68
ii)	2	13.5	2.18	0.55
iii)	3	17	1.73	0.42

NOTE — The above pipes are recommended for water temperatures ranging from +1 to +90°C. The recommended maximum safe working stress for these pipes is 8.6 MPa at 27°C. At higher temperature up to 90°C, the strength of the pipe reduces and the working pressure shall be modified in accordance with Fig. 1. Occasional rise in temperature as in summer season with concurrent corresponding reduction in temperature during nights has no deleterious effect on the life/working pressure of the pipes considering the total life of pipes.

## 6 COMPOSITION

**6.1** The material from which the pipe is produced shall consist substantially of chlorinated polyvinyl chloride to which may be added only those additives that are needed to facilitate the manufacture of the pipe and the production of sound and durable pipe of good surface finish, mechanical strength and opacity under conditions of use. None of these additives shall be used separately or together in quantities sufficient to constitute a toxic, organoleptic or microbial growth hazard or materially to impair the fabrication or welding properties of the pipe, or to impair the chemical, physical or mechanical properties (in particular long-term mechanical strength and impact strength) as defined in this standard.

### 6.2 Resin

#### 6.2.1 Chlorine Content

The chlorinated polyvinyl chloride polymer from which the pipe compound are to be manufactured shall have

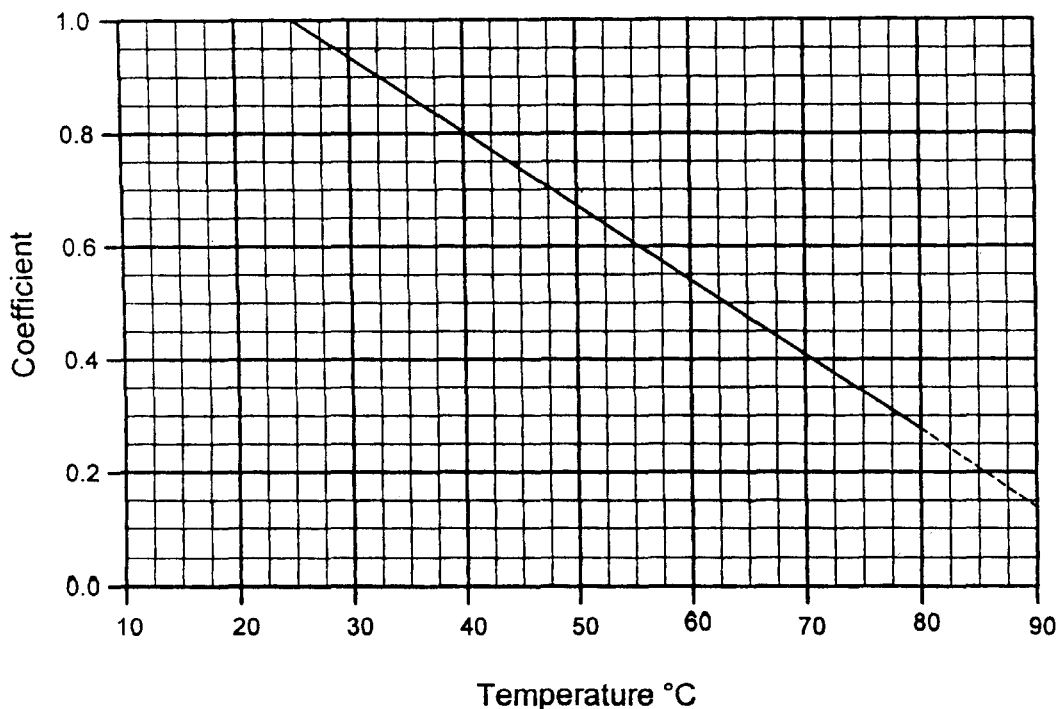

FIG. 1 GRAPH FOR MORE PRECISE CALCULATIONS GIVING THE MAXIMUM CONTINUOUS WORKING PRESSURE (COEFFICIENT) FOR TEMPERATURE UP TO 90°C

chlorine content not less than 66.5 percent when tested in accordance with Annex B.

### 6.3 Compound Properties

The compound shall meet the requirement of IS 15225 for chlorinated polyvinyl chloride compound used for pipes and fittings. It shall have performance designation of D.P.110-2-3-2, as per designation system given in 4.2 of IS 15225.

#### 6.3.1 Chlorine Content

The chlorinated polyvinyl chloride pipe compounds containing additives such as modifiers, lubricants, fillers, etc, from which the pipes are to be manufactured, shall have a chlorine content not less than 60 percent when tested in accordance with Annex B.

#### 6.3.2 Verification of the Malfunction Temperature, $T_{mal}$

When tested as per the method given in Annex C, at  $95 \pm 2^\circ \text{C}$  and at a test pressure of 1.0 MPa for 1 000 h, the pipe shall not leak during the prescribed test duration.

#### 6.3.3 Density

The chlorinated polyvinyl chloride pipe compounds containing additives such as modifiers, lubricants, fillers, etc, from which the pipes are to be manufactured,

shall have a density between 1 450 kg/m<sup>3</sup> and 1 650 kg/m<sup>3</sup>, when tested in accordance with IS 13360 (Part 3/Sec 1).

## 7 DIMENSIONS OF PIPES

The outside diameter, outside diameter at any point and wall thickness shall be as given in Table 2.

### 7.1 Diameter

The outside diameter and outside diameter at any point as given in Table 2 shall be measured according to the method given in IS 12235 (Part 1).

#### 7.1.1 Diameter at any Point

The difference between the measured maximum outside diameter and measured minimum outside diameter in the same cross-section of pipe (also called tolerance on ovality) shall not exceed the greater of the following two values:

- a) 0.5 mm, and
- b)  $0.012 d_n$  rounded off to the next higher 0.1 mm.

#### 7.1.2 Wall Thickness

The wall thickness of the pipes shall be as given in Table 2.

Table 2 Dimensions of Chlorinated Polyvinyl Chloride Pipes

(Clauses 7, 7.1, 7.1.2 and 7.1.2.1)

All dimensions in millimetres.

Sl No.	Nominal Size	Nominal Outside Diameter	Mean Outside Diameter		Outside Diameter at Any Point		Wall Thickness								
			Min	Max	Min	Max	Class 1, SDR 11			Class 2, SDR 13.5			Class 3, SDR 17		
							Avg	Max	Min	Max	Avg	Max	Min	Max	Avg
(1)	(2)	(3)	(4)	(5)	(6)	(7)	(8)	(9)	(10)	(11)	(12)	(13)	(14)	(15)	(16)
i)	15	15.9	15.8	16.0	15.8	16.0	2.2*	1.7*	2.2*	1.9*	1.4*	1.9*	-	-	-
ii)	20	22.2	22.1	22.3	22.0	22.4	2.5	2.0	2.5	2.2	1.7	2.2	-	-	-
iii)	25	28.6	28.5	28.7	28.4	28.8	3.1	2.6	3.1	2.6	2.1	2.6	-	-	-
iv)	32	34.9	34.8	35.0	34.7	35.1	3.7	3.2	3.7	3.1	2.6	3.1	-	-	-
v)	40	41.3	41.2	41.4	41.1	41.5	4.3	3.8	4.3	3.6	3.1	3.6	-	-	-
vi)	50	54.0	53.9	54.1	53.7	54.3	5.5	4.9	5.5	4.6	4.0	4.6	-	-	-
vii)	65	73.0	72.8	73.2	72.2	73.8	-	-	-	-	-	-	4.8	4.3	4.8
viii)	80	88.9	88.7	89.1	88.1	89.7	-	-	-	-	-	-	5.9	5.2	5.9
ix)	100	114.3	114.1	114.5	113.5	115.1	-	-	-	-	-	-	7.5	6.7	7.5
x)	150	168.3	168.0	168.6	166.5	170.1	-	-	-	-	-	-	11.1	9.9	11.1

## NOTES

1 All dimensions with '\*\*' are not a function of SDR.

2 For CPVC pipes SDR is calculated by dividing the average outer diameter of the pipe in mm by the minimum wall thickness in mm. If the wall thickness calculated by this formula is less than 1.52 mm, it shall be increased to 1.52 mm. The SDR values shall be rounded to the nearest 0.5.



Wall thickness shall be measured by any of the three methods given in IS 12235 (Part 1). To check the conformity of the wall thickness of the pipe throughout its entire length, it is necessary to measure the wall thickness of the pipe at any point along its length. This shall be done by cutting the pipe at any point along its length and measuring the wall thickness as above. Alternatively, to avoid destruction of the pipe, non-destructive testing methods such as the use of ultrasonic wall thickness measurement gauges shall be used at any four points along the length of the pipe.

#### 7.1.2.1 Tolerance on wall thickness

- For pipes of minimum wall thickness 6 mm or less, the permissible variation between the minimum wall thickness ( $e_{\text{Min}}$ ) and the wall thickness at any point ( $e$ ), ( $e - e_{\text{Min}}$ ) shall be positive in the form of  $+y$ , where  $y = 0.1e_{\text{Min}} + 0.2$  mm.
- For pipes of minimum wall thickness greater than 6 mm, the permissible variation of wall thickness shall again be positive in the form of  $+y$ , where  $y$  would be applied in two parts.
- The average wall thickness shall be determined by taking at least six measurements of wall thickness round the pipe and including both the absolute minimum and absolute maximum measured values. The tolerance applied to this average wall thickness from these measurements shall be within the range  $0.1e_{\text{Min}} + 0.2$  mm (see Table 2).
- The maximum wall thickness at any point shall be within the range  $0.15e_{\text{Min}}$  (see Table 2).
- The results of these calculations for checking tolerance shall be rounded off to the next higher 0.1 mm.

#### 7.1.3 Length

##### 7.1.3.1 Effective length ( $L_e$ )

If the length of a pipe is specified, the effective length shall not be less than that specified. The preferred effective length of pipes shall be 3, 5, or 6 m. The pipes may be supplied in other lengths where so agreed upon between the manufacturer and the purchaser.

## 8 PIPE ENDS

The ends of the pipes meant for solvent cementing shall be cleanly cut and shall be reasonably square to the axis of the pipe or may be chamfered at the plain end.

## 9 PHYSICAL AND CHEMICAL CHARACTERISTICS

### 9.1 Visual Appearance

The colour of the pipes shall be off-white. Slight variations in the appearance of the colour are permitted.

9.1.1 The internal and external surfaces of the pipe shall be smooth, clean and free from grooving and other defects.

### 9.2 Opacity

The wall of the plain pipe shall not transmit more than 0.1 percent of the visible light falling on it when tested in accordance with IS 12235 (Part 3).

### 9.3 Effect on Water

The pipes shall not have any detrimental effect on the composition of the water flowing through them, when tested as per 10.3 of IS 4985.

### 9.4 Reversion Test

When tested by the method prescribed in IS 12235 (Part 5/Sec 1 and Sec 2), a length of pipe  $200 \pm 20$  mm long shall not alter in length by more than 5 percent.

### 9.5 Vicat Softening Temperature

When tested by the method prescribed in IS 12235 (Part 2), the Vicat softening temperature of the specimen shall not be less than 110°C.

### 9.6 Density

When tested in accordance with IS 12235 (Part 14), the density of the pipes shall be between 1 450 kg/m<sup>3</sup> and 1 650 kg/m<sup>3</sup>.

## 10 MECHANICAL PROPERTIES

### 10.1 Hydrostatic Characteristics

When subjected to internal hydrostatic pressure test in accordance with the procedure given in IS 12235 (Part 8/Sec 1), the pipe shall not fail during the prescribed test duration. The temperatures, duration and hydrostatic (hoop) stress for the test shall conform to the requirements given in Table 3. The test shall be carried out not earlier than 24 h after the pipes have been manufactured.

### 10.2 Thermal Stability by Hydrostatic Pressure Testing

When subjected to internal hydrostatic pressure test in accordance with the procedure given in IS 12235 (Part 8/Sec 1) and as per requirement given in Table 3, SI No. (iv), the pipe shall not burst or leak during the prescribed test duration.

### 10.3 Resistance to External Blow at 0°C

When tested by the method prescribed in IS 4985, with classified striker mass and drop height as given in Table 4, the pipe shall have a true impact rate of not more than 10 percent.

### 10.4 Flattening Test

When tested by the method prescribed in IS 12235

**Table 3 Requirements of Pipes for Internal Hydrostatic Pressure Test***(Clause 10.1)*

Sl No.	Test	Test Temperature <i>Min</i> °C	Test Period h	Hydrostatic (Hoop) Stress MPa
(1)	(2)	(3)	(4)	(5)
i)	Acceptance	20	1	43.0
ii)	Type	95	165	5.6
iii)	Type	95	1 000	4.6
iv)	Type	95	8 760	3.6 (Test for thermal stability)

(Part 19), pipe shall show no signs of cracking, splitting and breaking.

### 10.5 Tensile Strength

When tested by the method prescribed in IS 12235 (Part 13), the tensile strength at yield shall not be less than 50 MPa at  $27 \pm 2^\circ\text{C}$ .

### 11 SAMPLING AND CRITERIA FOR CONFORMITY

The sampling procedure and criteria for conformity shall be as given in Annex D.

### 12 MARKING

**12.1** Each pipe shall be clearly and indelibly marked in ink/paint or hot embossed on white base at intervals of not more than 3 m. The marking shall show the following:

- a) Manufacturer's name or trade-mark,
- b) Outside diameter,
- c) Class of pipe and pressure rating, and
- d) Batch or Lot number.

### 12.2 BIS Certification Marking

Each pipe may also be marked with the Standard Mark.

**12.2.1** The use of the Standard Mark is governed by the provisions of the *Bureau of Indian Standards Act, 1986* and the Rules and Regulations made thereunder. The details of conditions under which a license for the use of the Standard Mark may be granted to the manufacturers or the producers may be obtained from the Bureau of Indian Standards.

**Table 4 Classified Striker Mass and Drop Height Conditions for the Falling Weight Impact Test***(Clause 10.3)*

Sl No.	Nominal Pipe Size mm	Mass of Falling Weight kg	Falling Height mm
(1)	(2)	(3)	(4)
i)	15	$0.5 \pm 0.5\%$	$300 \pm 10$
ii)	20	$0.5 \pm 0.5\%$	$400 \pm 10$
iii)	25	$0.5 \pm 0.5\%$	$500 \pm 10$
iv)	32	$0.5 \pm 0.5\%$	$600 \pm 10$
v)	40	$0.5 \pm 0.5\%$	$800 \pm 10$
vi)	50	$0.5 \pm 0.5\%$	$1\ 000 \pm 10$
vii)	65	$0.8 \pm 0.5\%$	$1\ 000 \pm 10$
viii)	80	$0.8 \pm 0.5\%$	$1\ 200 \pm 10$
ix)	100	$1.0 \pm 0.5\%$	$1\ 600 \pm 10$
x)	150	$1.6 \pm 0.5\%$	$2\ 000 \pm 10$

## ANNEX A

(Clause 2)

## LIST OF REFERRED INDIAN STANDARDS

IS No.	Title	IS No.	Title
4905 : 1968	Methods for random sampling	Sec 1 : 2004	Resistance to internal hydrostatic pressure at constant internal water pressure ( <i>first revision</i> )
4985 : 2000	Unplasticized PVC pipes for potable water supplies — Specification ( <i>third revision</i> )	(Part 13) : 2004	Determination of tensile strength and elongation ( <i>first revision</i> )
12235	Thermoplastics pipes and fittings— Methods of test :	(Part 14) : 2004	Determination of density/relative density (specific gravity) ( <i>first revision</i> )
(Part 1) : 2004	Measurement of dimensions ( <i>first revision</i> )	(Part 19) : 2004	Flattening test ( <i>first revision</i> )
(Part 2) : 2004	Determination of Vicat softening temperature ( <i>first revision</i> )	13360	Plastics — Methods of testing:
(Part 3) : 2004	Test for opacity ( <i>first revision</i> )	(Part 3/Sec 1) :	Part 3 Physical and dimensional properties, Section 1 Determination of density and relative density of non-cellular plastics
(Part 5)	Longitudinal reversion	1995	
Sec 1 : 2004	Determination methods ( <i>first revision</i> )	15225 : 2002	Chlorinated polyvinyl chloride compounds used for pipes and fittings — Specification
Sec 2 : 2004	Determination parameters ( <i>first revision</i> )		
(Part 8)	Resistance to internal hydrostatic pressure		

## ANNEX B

(Clauses 6.2.1 and 6.3.1)

## METHOD FOR THE DETERMINATION OF THE CHLORINE CONTENT

**B-1 COMBUSTION IN BOMB TECHNIQUE METHOD****B-1.1 Scope**

This test method covers the determination of chlorine in CPVC materials by the combustion in bomb technique.

**B-1.2 Principle**

The test sample is oxidized with sodium peroxide followed by potentiometric or volumetric titration of the resulting chlorides.

**B-1.3 Reagents**

**B-1.3.1** *Silver Nitrate*, standard volumetric solution (0.1 mol/l or 0.05 mol/l).

**B-1.3.2** *Nitric Acid*, solution 2 mol/l.

**B-1.3.3** *Sodium Peroxide*, granulated.

**B-1.3.4** *Starch*, sucrose or ethylene glycol, as combustion aids.

**B-1.4 Apparatus**

**B-1.4.1** *Drying Oven*, capable of being maintained at

50 ± 2° C or 75 ± 2° C.

**B-1.4.2** *Equipment for Volhard titration or for Potentiometric Titration*, with a burette having a capacity and accuracy appropriate to the chosen method.

**B-1.4.3** *Combustion Bomb* (for example Parr bomb or another bomb which gives the same results), gas or electrically fired. An example of suitable gas fired bomb is shown in Fig. 2.

**B-1.4.4** *Nickel Crucible* with lid, to fit onto the bomb (gas fired) suitable dimensions are 25 mm dia and 40 mm height. A smaller crucible could be used if the amount of test sample is reduced.

**B-1.4.5** *Safety Oven*

**B-1.4.6** *Beaker*, capacity 600 ml.

**B-1.4.7** *Balance*, accuracy 0.1 mg.

**B-1.5 Test Sample**

The sample shall be in powdered or granular form, and if necessary shall be cut in to the pieces 1 mm to 3 mm in size. The sample shall be oven dried for 2 h at 75° C or 16 h at 50° C.

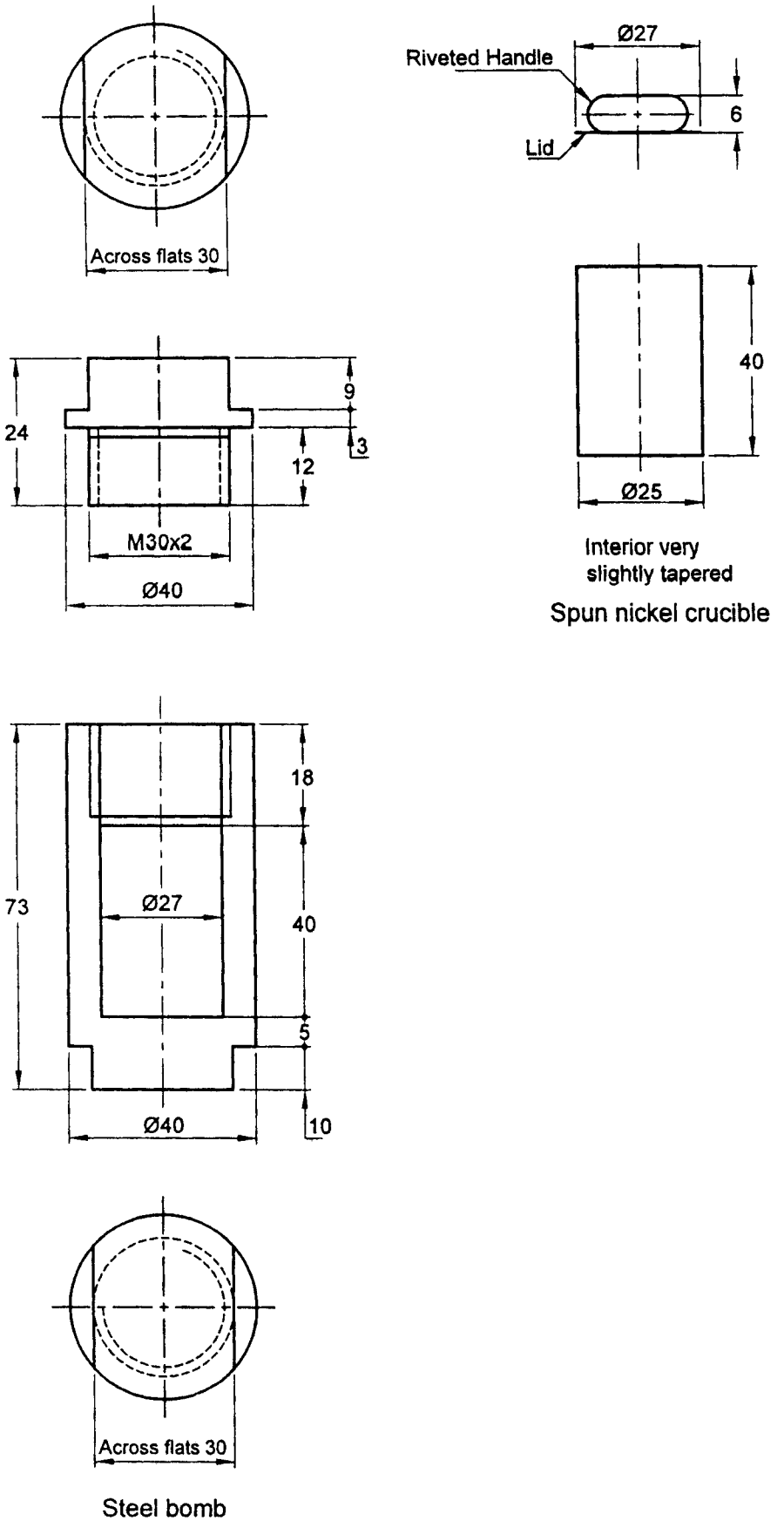

Approximate dimensions in millimetres.

FIG. 2 COMBUSTION BOMB, GAS-FIRED TYPE

## B-1.6 Procedure

**B-1.6.1** First place 7 g to 7.5 g of sodium peroxide in the nickel crucible (for the gas fired bomb) or in the fusion cup of the bomb (for the electrically fired bomb), then add a test portion of about 0.25 g (weighed to 0.1 mg) mixed with 0.16 g to 0.17 g of combustion aid, then a further 7 g to 7.5 g of sodium peroxide. The placing of sodium peroxide in the crucible or fusion cup shall be done behind a shield protecting the operator. Mix by stirring, then place the crucible, with the lid in position, inside the bomb and close the bomb tightly. If an electrically fired bomb is used, assemble the bomb and tap it to settle the charge. A smaller crucible and test portion could be used.

**B-1.6.2** Fire the bomb, if the gas fired bomb is used, place it in the safety oven. Adjust the flame beforehand, using an empty bomb in the safety oven so that the top of the flame is a few millimeters from the base of the bomb. Then remove the empty bomb. Heat the test bomb at 300° C to 400° C for about 10 min. Ignition usually start at 50° C to 60° C, and is detected by a cracking sound, and the fact that the bottom of the bomb starts to glow.

**B-1.6.3** Cool the bomb, open it and if a gas fired bomb is used, remove the crucible and carefully place it in 100 ml of distilled water in 600 ml beaker and immediately cover the beaker with a watch glass. When the reaction has subsided, wash down the inside of the bomb and the plug, collecting the washings in the beaker.

If the electrically fired bomb is used, dismantle it after cooling, remove the head and tip the contents in 100 ml of distilled water in the beaker. Lay the fusion cup in the same beaker and immediately cover with a watch glass.

**WARNING** — If the bomb is cooled in water, take care that the water does not reach the joint between the plug and the bomb.

**B-1.6.4** Heat the beaker and its content to boiling, then cool. Remove the crucible and lid, or the fusion cup and head, rinsing them with water and collecting water the washings in the beaker.

**B-1.6.5** Slowly add 20 ml of concentrated nitric acid, stirring constantly, followed by nitric acid solution until the mixture is neutral. Then add a further 2 ml of nitric acid solution.

**NOTE** — Methyl orange is a suitable indicator for the neutralization.

**B-1.6.6** Dilute the content of the beaker to about 200 ml with water and titrate potentiometrically or by the Volhard method with silver nitrate solution.

**B-1.6.7** Carry out a blank test by firing the same amount of sodium peroxide and combustion aid as was used with the test portion, and repeating the procedure (but without the test sample) described in 1.6.4 to 1.6.7.

**B-1.6.8** When doubt exists as to the whether the reaction has taken place, do not dissolve the contents of the bomb in water by the normal procedure because this might cause the violent explosion. The contents of the bomb should be spread out on dry sand, after which they should be sprayed with water from a safe distance and then washed with more water.

## B-1.7 Calculations

**B-1.7.1** The chlorine content of the dry material, expressed as a percentage by mass is given by the following formula :

$$3.5453 \times \frac{0.1 \times (V_1 - V_2)}{m}$$

or

$$3.5453 \times \frac{0.05 \times (V_1 - V_2)}{m}$$

depending upon the concentration of the silver nitrate solution.

where

$V_1$  = volume of AgNO<sub>3</sub> used for determination, in ml;

$V_2$  = volume of AgNO<sub>3</sub> used for blank test, in ml; and

$m$  = mass of test sample, in g.

**B-1.7.2** Express the result as the arithmetic mean of the two determinations that do not differ by more than 0.2 percent (absolute).

## B-2 OXYGEN FLASK METHOD

### B-2.1 Scope

This test method covers the determination of chlorine in CPVC materials by the oxygen flask technique.

### B-2.2 Principle

The test sample is oxidized with gaseous oxygen followed by potentiometric or volumetric titration of the resulting chlorides.

### B-2.3 Reagents

**B-2.3.1** *Silver Nitrate*, standard volumetric solution (0.1 mol/l or 0.05 mol/l).

**B-2.3.2** *Nitric Acid Solution*, 2 mol/l.

**B-2.3.3** *Oxygen*, gaseous.

**B-2.3.4** *Sodium Nitrate*

**B-2.3.5** *Potassium Hydroxide Solution*, 100 g/l.

**B-2.3.6** *Hydrogen Peroxide Solution*, 300 g/l.

### B-2.4 Apparatus

**B-2.4.1** *Drying Oven*, capable of being maintained at 50 ± 2° C or 75 ± 2° C.

**B-2.4.2** Balance, to weigh to an accuracy of 0.01 g.

**B-2.4.3** Equipment for Volhard Titration or Potentiometric Titration, with a burette having a capacity and accuracy appropriate to the chosen method,

**B-2.4.4** Round or Flat Bottom Flask, capacity 500 ml to 1 000 ml with head design for oxygen combustion (see Fig. 3). A platinum wire 1.0 mm in diameter and 120 mm long in the shape of a tapered spiral is attached to the stopper, a suitable spiral being 15 mm in diameter and 15 mm long. It is recommended that metal gauze be wrapped around the flask for safety.

**B-2.4.5** Filter Paper, about 3 cm × 3.5 cm, free from halogen and ash.

**B-2.4.6** Beaker, capacity 250 ml.

### B-2.5 Test Sample

The sample shall be in powdered or granular form, and if necessary shall be cut in to the pieces of 1 mm to 3 mm in size. The sample shall be oven dried for 2 h at 75° C or 16 h at 50° C.

### B-2.6 Procedure

**B-2.6.1** Place a test portion of about 25 mg to 35 mg weighed to 0.01mg on a filter paper cut as shown in Fig. 4 and having previously marked folds. Then fold the paper as shown in Fig. 4 (b), (c) and (d) and clamp it in the platinum spiral (see Fig. 3) with the paper tail protruding.

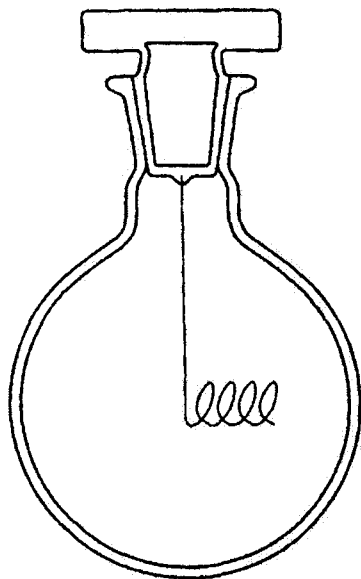

FIG. 3 FLASK FOR OXYGEN COMBUSTION WITH PLATINUM WIRE ATTACHED TO STOPPER

**B-2.6.2** Introduce about 20 ml of water, 1 ml of potassium hydroxide solution and 0.15 ml of hydrogen peroxide solution in to the flask pass oxygen through a glass tube at 250 ml/min to 350 ml/min for 5 min to displace the air.

**B-2.6.3** Ignite the filter paper tail with a gas flame and quickly insert the stopper carrying the platinum wire and burning filter paper in to the flask.

**B-2.6.4** During combustion, keep the flask inverted so that the liquid covers the bottom of the stopper and leakage through the stopper and escape of gas are avoided. when combustion is finished, turn the flask up right gently shake under a stream of cold water to cause rapid complete absorption of the hydrochloric acid produced.

**B-2.6.5** After 30 min open the flask and transfer the contains quantitatively to a 250 ml beaker, rinsing so that the final volume is about 60 ml, add about 1 g of sodium nitrate and 2.5 ml of nitric acid solution, and boil the solution for 5 min. After cooling, determine the chlorine content by potentiometric titration or by the Volhard method with silver nitrate solution.

**B-2.6.6** Carry out a blank test following the procedure described in B-2.6.1 to B-2.6.5 and using the same quantities of all the reagents used in the determination, but without the test portion.

### B-2.7 Calculations

**B-2.7.1** The chlorine content of the dry material, expressed as a percentage by mass is given by the following formula :

$$3.5453 \times \frac{0.1 \times (V_1 - V_2)}{m}$$

or

$$3.5453 \times \frac{0.05 \times (V_1 - V_2)}{m}$$

depending upon the concentration of the silver nitrate solution used.

where

$V_1$  = volume of silver nitrate solution used for determination, in ml;

$V_2$  = volume of silver nitrate solution used for blank test, in ml; and

$m$  = mass of the test sample, in g.

**B-2.7.2** Express the result as the arithmetic mean of two determinations that do not differ by more than 0.2 percent (absolute).

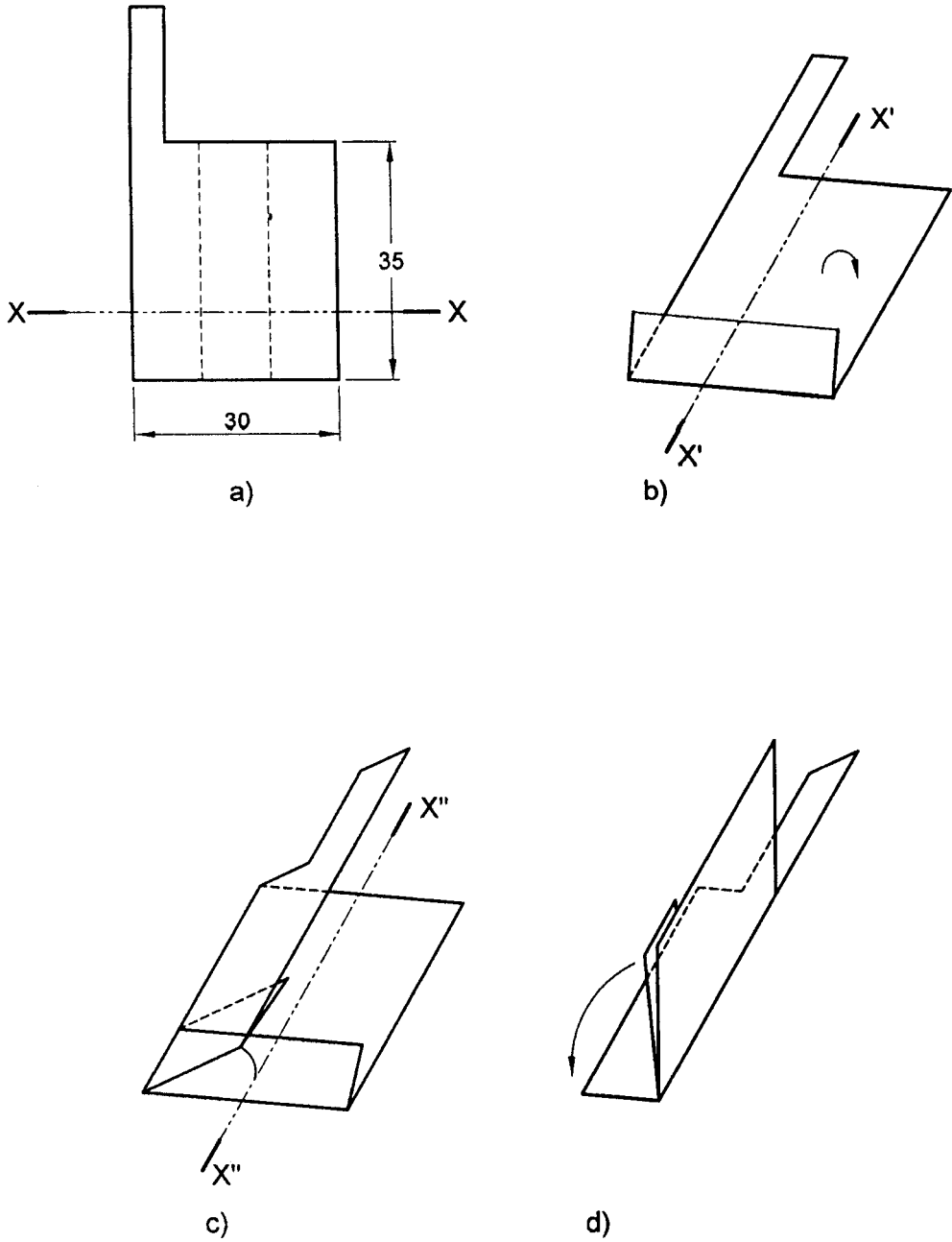

All dimensions in millimetres.

FIG. 4 FOLDING OF FILTER PAPER CONTAINING TEST PORTION

## ANNEX C

### (Clause 6.3.2)

#### TEST METHOD FOR THE VERIFICATION OF THE MALFUNCTION TEMPERATURE ( $T_{mal}$ ) OF CPVC MATERIAL

##### C-1 SCOPE

This Annex specifies a test method for verifying the malfunction temperature,  $T_{mal}$ , of chlorinated polyvinyl chloride material for piping system intended to be used for hot and cold water installation.

##### C-2 PRINCIPLE

An assembly of pipes and fittings (see Fig. 5) for testing the material subjected to a given internal water pressure under temperature for a given period during which the leak tightness of the system is verified by the inspection.

##### C-3 APPARATUS

**C-3.1 Pump**, capable of applying and maintaining the required pressure.

**C-3.2 Pressure Measurement Devices**, capable of checking conformity to the required test pressure.

**C-3.3 Heating Devices**, capable of applying and maintaining the required temperature.

**C-3.4 Thermometer or Equivalent**, capable of checking conformity to the required test temperature.

**C-3.5 Timer**, capable of recording the duration of the pressure application.

##### C-4 TEST PIECES

The assembly shall comprise test pieces of the following type:

- a) 10 pipe sections of the same lengths, each of them at least 300 mm and with a nominal outside diameter specified by the manufacture and capable of withstanding a hydrostatic stress of 4,6 MPa.
- b) 7 double sockets (couplers) of the same outside diameter as the pipe section; and
- c) 4 elbows, each of them with an angle of 90°.

The test pieces shall be jointed to each other according to Fig. 5.

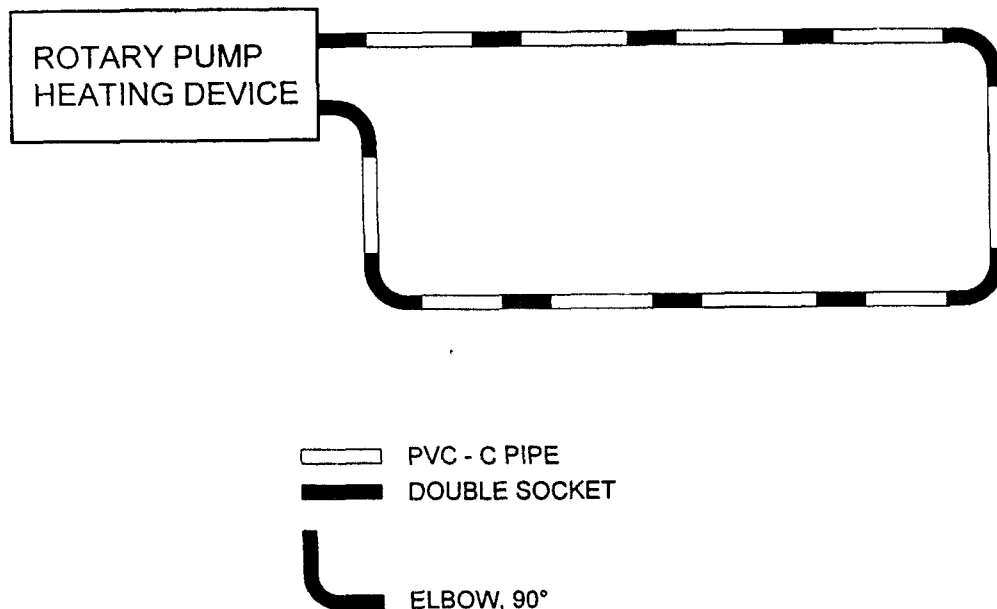

FIG. 5 ASSEMBLY OF PIPES AND FITTINGS FOR TESTING THE MATERIAL



**C-5 PROCEDURE**

**C-5.1** Conduct the following procedure using an assembly as given in Fig. 5 set up by solvent cementing the components. Store the components which have been connected by solvent cement for setting for at least 24 h at ambient temperature. Then condition the solvent cemented joints by filling the assembly with water at a temperature of  $95 \pm 2^\circ \text{C}$  for 48 h without applying the pressure. After the conditioning drain the water off.

**C-5.2** Refill the assembly with water at  $95 \pm 2^\circ \text{C}$  which is circulated by a pump and apply a test pressure of 1.0 MPa to the assembly.

**C-5.3** Maintain the water temperature at  $95 \pm 2^\circ \text{C}$ , test pressure of 1.0 MPa for at least 1 000 h, during which,

the assembly shall be continuously monitored for leak tightness.

**C-6 TEST REPORT**

The test report shall include the following information:

- a) Reference to this Annex of this standard;
- b) Complete identification of the sample;
- c) Test pressure, in MPa;
- d) Test temperature, in degree celsius;
- e) Time under pressure, in hour;
- f) Type(s) of failure, if any;
- g) Any factors which may have affected the results, such as any incidents or any operating details not specified in this Annex; and
- h) Date of the test.

**ANNEX D**

(Clause 11)

**SAMPLING AND CRITERIA FOR CONFORMITY****D-1 ACCEPTANCE TESTS**

**D-1.1** Acceptance tests are carried out on samples selected from a lot for the purpose of acceptance of the lot.

**D-1.2 Lot**

All CPVC pipes in a single consignment of the same class, same size and manufactured under essentially similar conditions shall constitute a lot.

**D-1.3** For ascertaining conformity of the lot to the requirements of the specification, samples shall be tested from each lot separately.

**D-1.4 Visual and Dimensional Requirements**

**D-1.4.1** The number of test samples to be taken from a lot shall depend on the size of the lot and the outside diameter of the pipes, and shall be in accordance with Table 5.

**D-1.4.2** These pipes shall be selected at random from the lot and in order to ensure the randomness of selection, a random number table shall be used. For guidance and use of random number tables, IS 4905 may be referred to. In the absence of a random number table, the following procedure may be adopted:

Starting from any pipe in the lot, count them as 1, 2, 3, etc, up to  $r$  and so on, where  $r$  is the integral part of  $N/n$ ,  $N$  being the number of pipes in the lot, and  $n$  the number of pipes in the sample. Every  $r$ th pipe so counted shall be withdrawn so as to constitute the required sample size.

**D-1.4.3** The number of pipes given for the first sample in col 4 of Table 5, shall be taken from the lot and examined for visual and dimensional requirements given in 7 and 9.1. A pipe failing to satisfy any of these requirements shall be considered as defective. The lot shall be deemed to have satisfied these requirements, if the number of defectives found in the first sample is less than or equal to the corresponding acceptance number given in col 6 of Table 5. The lot shall be deemed not to have met these requirements, if the number of defectives found in the first sample is greater than or equal to the corresponding rejection number given in col 7 of Table 5. If, however, the number of defectives found in the first sample lies between the corresponding acceptance and rejection numbers given in cols 6 and 7, a second sample of the size given in col 4 shall be taken and examined for these requirements. The lot shall be considered to have satisfied these requirements if the cumulative sample is less than or equal to the corresponding acceptance number given in col 6, otherwise not.

**Table 5 Scale of Sampling for Visual Appearance and Dimensional Requirements***(Clauses D-1.4.1 and D-1.4.3)*

Sl No.	Number of Pipes in the Lot	Sample Number	Sample Size	Cumulative Sample Size	Acceptance Number	Rejection Number
(1)	(2)	(3)	(4)	(5)	(6)	(7)
i)	Up to 1 000	First	13	13	0	2
		Second	13	26	1	2
ii)	1 001 to 3 000	First	20	20	0	2
		Second	20	40	1	2
iii)	3 001 to 10 000	First	32	32	0	3
		Second	32	64	3	4
iv)	10 001 and above	First	50	50	1	4
		Second	50	100	4	5

**D-1.5 Reversion Test**

**D-1.5.1** The lot, having satisfied visual and dimensional requirements, shall be tested for reversion as given in 9.4.

**D-1.5.2** For this purpose, the number of pipes given for the first sample in col 4 of Table 6 shall be taken from the lot. The sample pipe failing the reversion test shall be considered as defective. The lot shall be deemed to have met the requirements given in this specification for the reversion test, if the number of defectives found in the first sample is less than or equal to the corresponding acceptance number given in col 6. This lot shall be deemed not to have met these requirements, if the number of defectives found in the first sample is greater than or equal to the corresponding rejection number given in col 7. If, however, the number of

defectives in the first sample lies between the corresponding acceptance and rejection numbers given in col 6 and col 7, a second sample of size given in col 4 shall be taken and examined for the requirement. The lot shall be considered to have satisfied the requirements, if the number of defectives found in the cumulative sample is less than or equal to the corresponding acceptance number given in col 6, otherwise not.

**D-1.6 Vicat Softening Test**

**D-1.6.1** The lot, having satisfied visual and dimensional requirements shall be tested for Vicat softening temperature as given in 9.5.

**D-1.6.2** For this purpose, the procedure adopted for sampling and criteria for conformity shall be the same as that for reversion under D-1.5.2 using Table 6.

**Table 6 Scale of Sampling for Reversion, Vicat Softening Temperature and Density Test***(Clauses D-1.5.2, D-1.6.2 and D-1.7.2)*

Sl No.	Number of Pipes in the Lot	Sample Number	Sample Size	Cumulative Sample Size	Acceptance Number	Rejection Number
(1)	(2)	(3)	(4)	(5)	(6)	(7)
i)	Up to 1 000	First	5	5	0	2
		Second	5	10	1	2
ii)	1 001 to 3 000	First	8	8	0	2
		Second	8	16	1	2
iii)	3 001 to 10 000	First	13	13	0	2
		Second	13	26	1	2
iv)	10 001 and above	First	20	20	0	3
		Second	20	40	3	4

**D-1.7 Density**

**D-1.7.1** The lot, having satisfied the visual and dimensional requirements, shall be tested for density as given in 9.6.

**D-1.7.2** For this purpose, the procedure adopted for sampling and criteria for conformity shall be the same as that for reversion under **D-1.5.2** using Table 6.

**D-1.8 Resistance to External Blow at 0°C**

**D-1.8.1** The lot, having been found satisfactory according to **D-1.4**, **D-1.5**, **D-1.6** and **D-1.7** shall be tested for resistance to external blow at 0°C as given in 10.2.

**D-1.8.2** For this purpose, the procedure adopted for sampling and criteria for conformity shall be as specified in Table 4 and Table 7.

**D-1.9 Internal Hydrostatic Pressure Test (Acceptance Test)**

**D-1.9.1** The lot, having been found satisfactory according to **D-1.4**, **D-1.5**, **D-1.6**, **D-1.7** and **D-1.8** shall be subjected to the requirements of the acceptance test for internal hydrostatic pressure as given in 10.1 and Table 3, SI No. (i). The number of pipes to be taken from the lot shall depend on the size of the lot and shall be according to Table 8.

**D-1.9.2** The pipes shall be taken at random from the lot. In order to ensure the randomness of selection, procedures given in IS 4905 may be followed.

**D-1.9.3 Number of Tests and Criteria for Conformity**

The number of test samples shall be as given in Table 8. The lot shall be considered to have satisfied the requirements for this test, if the number of test samples failing in this requirement is equal to the corresponding acceptance number given in col 4 of Table 8.

**D-2 TYPE TESTS**

**D-2.1** Type tests are intended to prove the suitability and performance of a new composition or a new size of pipe. Such tests, therefore, need to be applied only when a change is made in polymer composition or when a new size of pipe is introduced. Type tests for compliance with **6.3.2**, **9.2**, **9.3**, **10.1** (Type test only) and **10.4** shall be carried out.

**D-2.1.1 Verification of Malfunction Temperature,  $T_{mal}$** 

For this test, the manufacturer or the supplier shall furnish to the testing authority one assembly, selected preferably from a regular production lot.

**D-2.1.2 Opacity**

For this test, the manufacturer or the supplier shall

**Table 7 Scale of Sampling for Resistance to External Blows at 0°C***(Clause D-1.8.2)*

SI No.	Number of Pipes in the Lot	Sample Number	Sample Size	Cumulative Sample Size	Acceptance Number	Rejection Number
(1)	(2)	(3)	(4)	(5)	(6)	(7)
i)	Up to 3 000	First	3	3	0	2
		Second	3	6	1	2
ii)	3 001 to 10 000	First	3	5	0	2
		Second	5	10	1	2
iii)	10 001 and above	First	8	8	0	2
		Second	8	10	1	2

**Table 8 Scale of Sampling for Internal Hydrostatic Test***(Clauses D-1.9.1 and D-1.9.3)*

SI No.	Number of Pipes in the Lot	Sample Size	Acceptance Number
(1)	(2)	(3)	(4)
i)	Up to 3 000	2	0
ii)	3 001 to 10 000	3	0
iii)	10 001 and above	5	0

furnish to the testing authority one sample of the pipe of the thinnest wall section, selected preferably from a regular production lot.

**D-2.1.2.1** The sample so selected shall be tested for compliance with requirements for opacity as given in 9.2.

**D-2.1.2.2** If the sample passes the requirements of the opacity test, the type of the pipe under consideration shall be considered to be eligible for approval, which shall be valid for a period of one year.

**D-2.1.2.3** In case the sample fails in the test, the testing authority, at its discretion, may call for a fresh sample and subject the same to the opacity test. If the sample passes the repeat test, the type of pipe under consideration shall be considered eligible for approval. If the sample fails in the repeat test, the type of pipe shall not be approved. The manufacturer or the supplier may be asked to improve the design and re-submit the product for type approval.

**D-2.1.2.4** At the end of the validity period (normally one year) or earlier, if necessary, the testing authority may call for a fresh sample for opacity test for the purpose of type approval.

#### **D-2.1.3** *Test for Effect on Water*

For this type test, the manufacturer or the supplier shall furnish to the testing authority three samples of the smallest size of pipe taken from each machine (selected preferably from a regular production lot).

**D-2.1.3.1** Three samples so selected shall be tested for compliance with the requirements for effect on water as given in 9.3.

**D-2.1.3.2** If all three samples pass the requirements for effect on water, the type test of the pipe under consideration shall be considered to be eligible for approval, which shall be normally valid for a period of one year.

**D-2.1.3.3** In case any of the samples fails in this test, the testing authority, at its discretion, may call for fresh samples not exceeding the original number, and subject them to the test for effect on water. If, in the repeat test, no single failure occurs, the type of pipe under consideration shall be considered eligible for type approval. If any of the samples fails in the repeat test, the type of pipe shall not be approved. The manufacturer or the supplier may be asked to improve the design and resubmit the product for type approval.

**D-2.1.3.4** At the end of the validity period (normally one year) or earlier, if necessary, the testing authority may call for fresh samples for effect on water test for the purpose of type approval.

#### **D-2.1.4** *Internal Hydrostatic Pressure Test (Type Test) and Thermal Stability*

For this type test, the manufacturer or the supplier shall furnish to the testing authority, three samples of pipes of different diameters and different classes (selected preferably from a regular production lot).

**D-2.1.4.1** Three samples so selected shall be tested for compliance with the requirements of type test given in Table 3.

**D-2.1.4.2** If all the three samples pass the requirements of the quality test, the type of pipe under consideration shall be considered to be eligible for type approval which shall be normally valid for a period of one year.

**D-2.1.4.3** In case any of the samples fail in this test, the testing authority, at its discretion, may call for fresh samples not exceeding the original number and subject them to the type test. If, in the repeat test, no single failure occurs, the type of pipe shall be considered for type approval. If any of the samples fails in the repeat tests, the type of pipe shall not be approved. The manufacturer or the supplier may be asked to improve the design and resubmit the product for type approval.

**D-2.1.4.4** At the end of the validity period (normally one year) or earlier, if necessary, the testing authority may call for fresh samples for type test for the purpose of type approval.

#### **D-2.1.5** *Tensile Strength Test (Type Test)*

For this type test, the manufacturer or the supplier shall furnish to the testing authority, five samples of pipe of different diameters and different class (selected preferably from a regular production lot).

**D-2.1.5.1** Five samples so selected shall be tested for compliance with the requirements of type test given in 10.4.

**D-2.1.5.2** If all the five samples pass the requirement of the quality test, the type test of pipe under consideration shall be considered to be eligible for type approval which shall be normally valid for a period of one year.

**D-2.1.5.3** In case any of the sample fails in this test, the testing authority, at its discretion, may call for fresh samples not exceeding the original numbers and subject them to the type test. If, in the repeat test no single failure occurs, the type of pipe shall be considered for type approval. If any of the samples fail in the repeat tests, the type of pipe shall not be approved. The manufacturer or the supplier may be asked to improve the design and resubmit the product for type approval.

**D-2.1.5.4** At the end of the validity period (normally one year) or earlier, if necessary, the testing authority may call for fresh samples for type test for the purpose of type approval.

## ANNEX E

(Foreword)

### GUIDELINES FOR STORAGE AND INSTALLATION

#### E-1 STORAGE

CPVC pipes of all sizes are packed in polyethylene packing rolls and both the ends of the packed roll are sealed with air bubble film cap in order to provide protection during handling and transportation. After packing, the whole bunch of pipes is tightened with polypropylene/HDPE strapping. Each roll is then marked with size/ type of the pipe, lot number and quantity. The packed pipe rolls are stored in their respective racks in properly covered storage area. Apart from providing protection during handling and transportation, the packing rolls also protect the pipe from ultra violet rays.

#### E-2 INSTALLATION GUIDELINES

**E-2.1** Visually inspect pipe ends before making the joint. Use of a chamfering tool will help identify any cracks, as it will catch on to any crack.

**E-2.2** Pipe may be cut quickly and efficiently by several methods. Wheel type plastic tubing cutters are preferred. Ratchet type cutter or fine tooth saw are another options. However, when using the ratchet cutter be certain to score the exterior wall by rotating the cutter blade in circular motion around the pipe. Do this before applying significant downward pressure to finalize the cut. This step leads to a square cut. In addition, make sure ratchet cutter blades are sharp. Cutting tubing as squarely as possible provides optimal bonding area within a joint.

**E-2.3** Burrs and filings can prevent proper contact between the tube and fittings during the assembly, and should be removed from the outside and inside of the tube. A chamfering tool is preferred, but a pocket knife or file is also suitable for this purpose.

**E-2.4** Use only CPVC cement jointing. Use CPVC cement, which is dully recommend by the manufacturer.

**E-2.5** When using adhesive solution/solvent cement be certain of proper ventilation.

**E-2.6** When making a joint, apply a heavy, even coat of cement to the pipe end. Use the same applicator without additional cement to apply a thin coat inside the fitting socket. Too much cement can cause clogged waterways. Do not allow excess cement to puddle in the fitting and pipe assembly. This could result in a weakening of the pipe wall and possible pipe failure when the system is pressurized.

**E-2.7** Rotate pipe one-quarter to one-half turn while inserting it into the fitting socket and remove the excess adhesive solution/solvent cement from the joint with clean rag. Once the pipe end is seated, hold it in place for 5 s to 10 s to allow the joint to set.

**E-2.8** When making a transition connection to metal threads, use a special transition fitting or CPVC male threaded adapter whenever possible. Do not over-torque plastic threaded connections. Hand tight plus one-half turn should be adequate.

**E-2.9** Hang or strap CPVC systems loosely to allow for thermal expansion. Do not use metal straps with sharp edges that might damage the tubing.

**E-2.10** CPVC stub outs for lavatories, closets and sinks are appropriate. However, on areas where there is a likelihood that movement or impact abuse will occur, metal pipe nipples may be a more appropriate stub-out material. Showerheads, tub spouts and outside sill cocks are examples.

**E-2.11** When connected to a gas water heater, CPVC tubing should not be located within 50 cm of the flue. For water heaters lacking reliable temperature control, this distance may be increased up to 1 m a metal nipple or flexible appliance connector should be utilized. This measure eliminates the potential for damage to plastic piping that might result from excessive radiant heat from the flue.

## Bureau of Indian Standards

BIS is a statutory institution established under the *Bureau of Indian Standards Act, 1986* to promote harmonious development of the activities of standardization, marking and quality certification of goods and attending to connected matters in the country.

### Copyright

BIS has the copyright of all its publications. No part of these publications may be reproduced in any form without the prior permission in writing of BIS. This does not preclude the free use, in the course of implementing the standard, of necessary details, such as symbols and sizes, type or grade designations. Enquiries relating to copyright be addressed to the Director (Publications), BIS.

### Review of Indian Standards

Amendments are issued to standards as the need arises on the basis of comments. Standards are also reviewed periodically; a standard along with amendments is reaffirmed when such review indicates that no changes are needed; if the review indicates that changes are needed, it is taken up for revision. Users of Indian Standards should ascertain that they are in possession of the latest amendments or edition by referring to the latest issue of 'BIS Catalogue' and 'Standards: Monthly Additions'.

This Indian Standard has been developed from Doc: No. CED 50 ( 7337 ).

### Amendments Issued Since Publication

Amend No.	Date of Issue	Text Affected

## BUREAU OF INDIAN STANDARDS

### Headquarters:

Manak Bhavan, 9 Bahadur Shah Zafar Marg, New Delhi 110002

Telephones: 2323 0131, 2323 3375, 2323 9402

website : [www.bis.org.in](http://www.bis.org.in)

### Regional Offices:

	Telephones
Central : Manak Bhavan, 9 Bahadur Shah Zafar Marg NEW DELHI 110002	{ 2323 7617 2323 3841
Eastern : 1/14 C.I.T. Scheme VII M, V.I.P. Road, Kankurgachi KOLKATA 700054	{ 2337 8499, 2337 8561 2337 8626, 2337 9120
Northern : SCO 335-336, Sector 34-A, CHANDIGARH 160022	{ 260 3843 260 9285
Southern : C.I.T. Campus, IV Cross Road, CHENNAI 600113	{ 2254 1216, 2254 1442 2254 2519, 2254 2315
Western : Manakalaya, E9 MIDC, Marol, Andheri (East) MUMBAI 400093	{ 2832 9295, 2832 7858 2832 7891, 2832 7892

**Branches** : AHMEDABAD. BANGALORE. BHOPAL. BHUBANESHWAR. COIMBATORE. FARIDABAD. GHAZIABAD. GUWAHATI. HYDERABAD. JAIPUR. KANPUR. LUCKNOW. NAGPUR. PARWANOO. PATNA. PUNE. RAJKOT. THIRUVANANTHAPURAM. VISAKHAPATNAM.

**AMENDMENT NO. 2 MAY 2013**  
**TO**  
**IS 15778 : 2007 CHLORINATED POLYVINYL CHLORIDE**  
**(CPVC) PIPES FOR HOT AND COLD WATER**  
**DISTRIBUTION SUPPLIES — SPECIFICATION**

*(Page 3, clause 6.3.1, line 4) — Substitute ‘55’ for ‘60’.*

(CED 50)

---

Reprography Unit, BIS, New Delhi, India