

इंटरनेट

मानक

Disclosure to Promote the Right To Information

Whereas the Parliament of India has set out to provide a practical regime of right to information for citizens to secure access to information under the control of public authorities, in order to promote transparency and accountability in the working of every public authority, and whereas the attached publication of the Bureau of Indian Standards is of particular interest to the public, particularly disadvantaged communities and those engaged in the pursuit of education and knowledge, the attached public safety standard is made available to promote the timely dissemination of this information in an accurate manner to the public.

“जानने का अधिकार, जीने का अधिकार”

Mazdoor Kisan Shakti Sangathan

“The Right to Information, The Right to Live”

“पुराने को छोड़ नये के तरफ”

Jawaharlal Nehru

“Step Out From the Old to the New”

IS 15683 (2006): Portable fire extinguishers - Performance and construction - [CED 22: Fire Fighting]



“ज्ञान से एक नये भारत का निर्माण”

Satyanarayan Gangaram Pitroda

“Invent a New India Using Knowledge”



“ज्ञान एक ऐसा खजाना है जो कभी चुराया नहीं जा सकता है”

Bhartrhari—Nitiśatakam

“Knowledge is such a treasure which cannot be stolen”

BLANK PAGE



IS 15683 : 2006

भारतीय मानक
दुबाहय अग्नि शामक — कार्यकारिता और निर्माण — विशिष्टि

Indian Standard

PORTABLE FIRE EXTINGUISHERS — PERFORMANCE
AND CONSTRUCTION — SPECIFICATION

ICS 13.220.10

© BIS 2006

BUREAU OF INDIAN STANDARDS
MANAK BHAVAN, 9 BAHADUR SHAH ZAFAR MARG
NEW DELHI 110002

August 2006

Price Group 10

AMENDMENT NO. 1 DECEMBER 2008
TO
IS 15683 : 2006 PORTABLE FIRE EXTINGUISHERS —
PERFORMANCE AND CONSTRUCTION —
SPECIFICATION

(Foreword) — Add the following after the second para:

'The following standards shall be withdrawn with the implementation of this standard:

- 1) IS 940 : 2003 Specification for portable fire extinguishers, water type (gas cartridge) *(fourth revision)*
- 2) IS 2171 : 1999 Specification for portable fire extinguishers, dry powder (cartridge type) *(fourth revision)*
- 3) IS 6234 : 2003 Specification for portable fire extinguishers, water type (stored pressure) *(second revision)*
- 4) IS 10204 : 2001 Specification for portable fire extinguisher, mechanical foam type
- 5) IS 13849 : 1993 Specification for portable fire extinguisher, dry powder type (stored pressure)
- 6) IS 15397 : 2003 Specification for portable fire extinguisher, mechanical foam type (stored pressure)

Clause 3.1(a) of IS 2878 : 2004 'Specification for fire extinguisher, carbon dioxide type (portable and trolley mounted) *(third revision)*' shall also be deleted simultaneously with the implementation of this standard.

(Page 1, clause 3.6, line 3) — Substitute ' $55 \pm 5^{\circ}\text{C}$ ' for ' $65 \pm 5^{\circ}\text{C}$ '.

(Page 2, clause 4, Note 3) — Delete '(Halotron, NAF, PV, HFC-36)'.

(Page 3, clause 6.1, line 3) — Substitute '3.5 MPa (35 bar)' for '3 MPa (30 bar)'.

[Page 3, clause 7.3.1(c)] — Substitute the following for the existing:

Amend No. 1 to IS 15683 : 2006

'c) not retain more than 10 percent (for dry chemical powder type) and 5 percent (for other extinguishers) of initial charge within the extinguisher, following complete discharge.'

(Page 6, Table 3, Sl No. 3, col 3) — Substitute ' 55 ± 5 ' for ' 60 ± 2 '.

(Page 7, Table 4) — Add the following Note at the end:

'NOTE — The fire rating shall be declared by the manufacturer based on the test report of a recognized laboratory.'

(Page 10, Table 5) — Add the following as Note 2 and renumber the existing note as Note 1:

'NOTE 2 — The fire rating shall be declared by the manufacturer.'

(Page 12, clause 8.3.3, line 18) — Substitute 'at the decision of the operator' for 'but not the back of the crib, at will'.

(Page 12, clause 8.3.3, last sentence) — Delete 'to ensure a continuous jet'.

[Page 13, Table 9, footnote marked ³] — Delete.

(Page 16, clause 9.1) — Delete last sentence.

(Page 16, clause 9.2.1.8.1, line 2) — Substitute ' $55 \pm 5^\circ\text{C}$ ' for ' 55°C '.

(Page 20, clause 9.9.1) — Substitute the following for the existing:

'Hose Assembly — Extinguishers having a mass of extinguishing medium greater than 3 kg, or a volume of extinguishing medium greater than 3 l shall be provided with a discharge hose.

The length of the flexible section of the hose assembly shall be 400 mm or greater.'

(Page 25, clause 10.2.2.2, Warning):

a) Delete 'Do not use ————— per extinguisher.'

Amend No. 1 to IS 15683 : 2006

b) Delete the entire 'NOTE'.

(Page 25, clause 10.2.3.1, last sentence) — Substitute the following for the existing:

'A written description for each use code symbol may be included as part of the code. The description should be readable.'

(CED 22)

AMENDMENT NO. 2 NOVEMBER 2009
TO
IS 15683 : 2006 PORTABLE FIRE EXTINGUISHERS —
PERFORMANCE AND CONSTRUCTION —
SPECIFICATION

(Page 6, clause 7.6.1, line 3) — Delete 'as defined in IS 6910' and add the following after first sentence:

'Figure 7 is an example of typical test apparatus for external corrosion test.'

(Page 10, Table 5) — Substitute the following for the existing table:

Table 5 Amount of Extinguishing Medium Used to Obtain Minimum Class B Rating of Extinguishers
(Clause 8.1.2)

Extinguishing Medium Content (Charge)				Minimum Class B Rating
Powder kg	Carbon Dioxide kg	Clear Agent kg	Foam or Water with Additives	
(1)	(2)	(3)	(4)	(5)
$1 \leq 2$	$1 \leq 2$	$1 \leq 2$	5	8 B
$2 < 1 \leq 3$	$2 < 1 \leq 5$	$2 < 1 \leq 4$	9	13 B
$3 < 1 \leq 4$	$1 > 5$	$4 < 1 \leq 6$	9	21 B

(Page 17, clause 9.2.5) — Shift clause 9.2.5 as 9.1.1 under clause 9.1 on page 16 and renumber the subsequent clauses from 9.2.6 onwards.

(Page 23, clause 10.1) — Add the following at the end:

'A small band of distinguishing colour of 5 percent of surface area shall be painted for different type of extinguishers.

Sl No.	Extinguishers	Band Colour
1	Water	Red
2	Powder	Blue
3	Foam	Yellow
4	Carbon Dioxide	Black
5	Clear Agent	Green

Amend No. 2 to IS 15683 : 2006

(Page 23, clause 10.2.1.1) — Add the following sentence at the end:

'The marks specified above shall be applied to the metal of the body by hard stamping or engraving.'

(Page 27, clause 11.1) — Insert the following figure at the end:

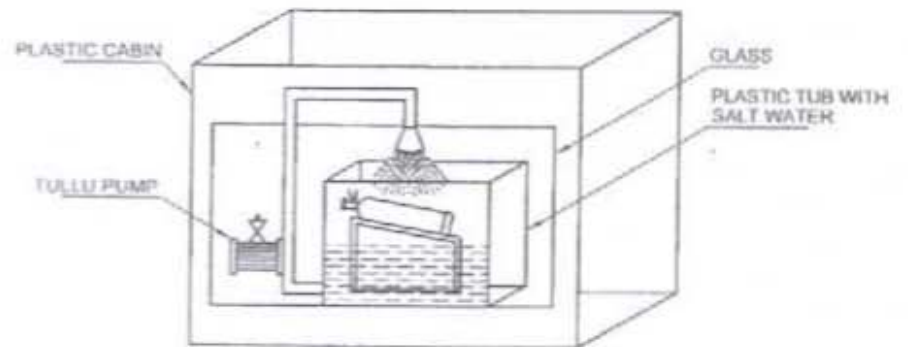

FIG. 7 TEST APPARATUS OF EXTERNAL CORROSION TEST

(CED 22)

Reprography Unit, BIS, New Delhi, India

AMENDMENT NO. 3 FEBRUARY 2010
TO
IS 15683 : 2006 PORTABLE FIRE EXTINGUISHERS
PERFORMANCE AND CONSTRUCTION
SPECIFICATION

(Page 23, clause 10.1) Delete the following last sentence:

‘The paint shall conform to IS 2932.’

(CED 22)

Reprography Unit, BIS, New Delhi, India

Fire Fighting Sectional Committee, CED 22

FOREWORD

This Indian Standard was adopted by the Bureau of Indian Standards, after the draft finalized by the Fire Fighting Sectional Committee had been approved by the Civil Engineering Division Council.

This standard has been prepared with a view to guide the industries for the manufacture and users in manufacturing and procuring various types of portable extinguishers, capable of giving satisfactory performance. The details with regard to maintenance are given in IS 2190 : 1992 'Code of practice for selection, installation and maintenance of first-aid fire extinguishers (*under revision*)'.

For the purpose of deciding whether a particular requirement of this standard is complied with, the final value observed or calculated, expressing the result of a test or analysis, shall be rounded off in accordance with IS 2 : 1960 'Rules for rounding off numerical values (*revised*)'. The number of significant places retained in the rounded off value should be the same as that of specified value in this standard.

*Indian Standard***PORTABLE FIRE EXTINGUISHERS — PERFORMANCE
AND CONSTRUCTION — SPECIFICATION****1 SCOPE**

This standard lays down requirements for performance, reliability and safety of portable fire extinguishers of all types specified in this standard.

2 REFERENCES

The standards listed at Annex A contain provisions which through reference in this text, constitute provisions of this standard. At the time of publication, the editions indicated were valid. All standards are subject to revision and parties to agreements based on this standard are encouraged to investigate the possibility of applying the most recent editions of the standards indicated at Annex A.

3 TERMINOLOGY

For the purposes of this standard, definitions given in IS 7673 and the following definitions shall apply:

3.1 Classification of Fires — Fires may be classified as follows:

3.1.1 Class A — Fires involving solid combustible materials of organic nature such as wood, paper, rubber, plastics etc, where the cooling effect of water is essential.

3.1.2 Class B — Fires involving flammable liquids or liquefiable solids or the like where a blanketing effect is essential.

3.1.3 Class C — Fires involving flammable gases under pressure including liquefied gases, where it is necessary to inhibit the burning gas at fast rate with an inert gas, powder or vaporizing liquid for extinguishment.

3.1.4 Class D — Fires involving combustible metals such as magnesium, aluminium, zinc, sodium, potassium, etc, when the burning metals are reactive to water containing agents and in certain cases carbon dioxide, halogenated hydrocarbons and ordinary dry powders. These fire require special media and techniques to extinguish.

3.2 Portable Extinguisher — Portable fire extinguishers are not expected to deal with large fires. Nevertheless, these are very valuable in the early stages of fire. The most important features of these extinguishers are their immediate availability and can be used by one/two

person(s). A fully charged portable fire extinguishers shall not be more than 17 kg. The extinguishing medium is discharged and directed into fire by storage pressure or release of pressurized charged storage in a cartridge.

3.3 Extinguishing Medium — Substance contained in the extinguisher that causes fire extinguishment such as water, foam, powder, gaseous agent (CO₂, halocarbon) etc.

3.4 Charge of Extinguisher — Mass (kg) or volume (litres) of the extinguishing medium contained in the extinguisher expressed in volume for water based extinguishers and in kg for gaseous and powder extinguishers.

3.5 Service Pressure (P_s) — Equilibrium pressure developed in a normally charged and pressurized extinguisher conditioned at $27 \pm 5^\circ\text{C}$ for at least 18 h stored pressure or pressure generated during actuation of gas cartridge.

3.6 Maximum Service Pressure (P_{ms}) — Equilibrium pressure developed in a normally charged and pressurized extinguisher which is conditioned at $65 \pm 5^\circ\text{C}$ for at least 18 h.

3.7 Complete Discharge of Extinguishing Medium in Percentage and Time — Point in the discharge of an extinguisher when the internal pressure has equalized with the external pressure, with the valve control being kept fully open that is the point at which pressure on dial becomes zero.

3.8 Effective Discharge Time — Time measured from the commencement of discharge of the extinguishing medium at the nozzle to the point of the discharge stream with the control valve fully open when 85 percent of extinguishant is discharged in case powder and 95 percent in case of water and gas based extinguishers.

3.9 Rechargeable Extinguisher — Extinguisher designed to be recharged after use.

3.10 Disposable Extinguisher (Non-rechargeable Extinguisher) — Extinguisher designed not to be recharged, but intended to be discarded after use.

3.11 Fill Density — Mass in kg of extinguishing medium

per litre of container volume for use, complete with valve and internal fittings.

3.12 Propellant — Non-flammable compressed gas used to expel the extinguishing medium that is CO₂ and N₂ etc.

3.13 Clean Agent — Electrically non-conductive gaseous or vaporizing liquid fire extinguishant that does not leave a residue upon evaporation and are not toxic to level of concentration at which it extinguishes the fire.

3.14 Lowest Observed Adverse Effect Level (LOAEL) — The lowest concentration of clean agent at which an adverse toxicological or physiological effect has been observed.

3.15 No Observed Adverse Effect Level (NOAEL) — The highest concentration of a clean agent at which no adverse toxicological or physiological effect has been observed.

4 CLASSIFICATION OF EXTINGUISHERS

Extinguishers shall be classified by the type of extinguishing medium which they contain. At present, the main types of extinguishers are:

- a) water or/and foam based,
- b) powder,
- c) carbon dioxide, and
- d) clean agents.

NOTES

1 These types of extinguishers may be further sub-divided, for example water-based extinguishers may contain pure water or water with additives such as wetting agents, viscosity-increasing agents, flame-retardant, or foaming agents, etc.

2 Powders may be of the 'BC' or 'ABC' types, or may be specially prepared for Class D (metals) fires.

3 Clean agents which are halon substitutes that is HFC, HCFC blends etc (Halotron, NAF PV, HFC-36), Fluoro ketone. The manufacture and use of halocarbon including halons are regulated by the Montreal Protocol and/or by national regulations.

5 EXTINGUISHING MEDIA, PROPELLANTS AND FILLING REQUIREMENTS

5.1 Extinguishing Media

5.1.1 Carbon Dioxide

Carbon dioxide used in extinguishers shall comply with IS 15222.

5.1.2 Clean Agents

Clean agents used in extinguishers shall comply with the IS 15493 or standard of clean agent supplied by manufacturer. (To be confirmed for test methods.)

5.1.3 Powders

Powder for Class BC should comply with IS 4308, for Class ABC IS 14609 and powders for use on Class D fires shall comply with IS 4861.

5.1.4 Foam Concentrates

Foam concentrates used in extinguishers shall comply with IS 4989 or ISO 7203.

NOTE — There is no Indian Standard covering non-foaming additives sometimes added to water to produce anti-freeze, wetting or other special characteristics. However, such extinguishers are included in the category of water-base extinguishers, the water-anti-freeze solution be tested for its freezing point and thawing. Calcium chloride solution shall not be used for stainless steel fire extinguishers.

5.2 Propellants

The propellants for stored pressure and cartridge-operated extinguishers shall be air, carbon dioxide, nitrogen or mixtures of these gases having a maximum dew-point of -55°C.

NOTE — Propellant for stored-pressure water-based extinguishers need not meet the above dew-point requirement.

5.3 Filling Requirements (Type Test)

5.3.1 Fill Density

The maximum fill density for carbon dioxide extinguishers shall not exceed 0.75 kg/l. The fill density for clean agent fire extinguishers shall not exceed the values given in the relevant standards.

5.3.2 Filling Tolerance

The actual charge of an extinguisher shall be the nominal charge within the following limits:

- a) water-foam based extinguisher : ± 3 percent by volume;
- b) powder extinguishers
 ≤ 1 kg nominal charge ± 5 percent by mass;
 > 1 kg but < 3 kg nominal charge ± 3 percent by mass;
 ≥ 3 kg nominal charge ± 2 percent by mass;
- c) clean-agent extinguishers
 ± 3 percent by mass; and
- d) carbon dioxide extinguishers
 ± 3 percent by mass.

5.3.3 Capacities

The following are the recommended capacities for fire extinguishers:

- a) water-foam based (litres) : 2, 3, 6, 9;
- b) powder (kg): 1, 2, 3, 4, 6, 9;

- c) CO₂ (kg): 2, 3, 4.5 and 5; and
 d) clean agent (kg): 1, 2, 4, 6.

6 PRESSURE REQUIREMENTS FOR LOW PRESSURE EXTINGUISHERS

6.1 Test Pressure (P_t)

The test pressure (P_t) for low-pressure extinguishers shall be $1.43 \times P_{m\text{a}}$ but in no case less than 2 MPa (20 bar).

For gaseous extinguisher, it should not be less than 3 MPa (30 bar).

6.2 Minimum Burst Pressure (P_b)

The minimum burst pressure (P_b) for low-pressure extinguishers is $2.7 \times P_{m\text{a}}$ but in no case less than 5.5 MPa (55 bar).

7 GENERAL OPERATING PERFORMANCE REQUIREMENTS

7.1 Operating Temperatures

Extinguishers shall be capable of operating reliably within one of the following temperature ranges of temperature:

- + 5 °C to + 55 °C
- 0 °C to + 55 °C
- 10 °C to + 55 °C
- 20 °C to + 55 °C
- 30 °C to + 55 °C

NOTE — The temperature range selected from the above shall be marked on the fire extinguisher (see 10.2.1.5).

7.2 Minimum Effective Discharge Time and Bulk Range of Discharge

7.2.1 Class A Rated Extinguishers

The minimum effective discharge time of extinguishers with 1A rating shall be no less than 8 s. Extinguishers with ratings of 2A or higher shall have a minimum discharge time of 13 s.

7.2.2 Class B Rated Extinguishers

The minimum effective discharge time of extinguishers with a Class B rating shall be no less than the value given in Table 1.

7.2.3 Bulk Range/Throw (Type Test)

7.2.3.1 Requirements

The minimum bulk range of extinguishers with a Class A rating shall be no less than 2 m when determined in accordance with 7.2.3.2.

Table 1 Minimum Effective Discharge Time of Class B Rated Extinguishers
(Clause 7.2.2)

Classification	Minimum Discharge Time s	Throw m
(1)	(2)	(3)
8B	8	1
13B	8	1
21B	8	2
34B	8	2

7.2.3.2 Test method

Carry out the test indoors having suitable lighting to give the best possible visibility of the extinguisher media during discharge. Use a black background marked to indicate the horizontal distance. Condition the extinguisher for no less than 18 h at a temperature of 27 ± 5 °C and place it in normal operating position with the discharge nozzle held horizontally 1 m above the floor. Fully discharge the extinguisher with the control valve fully open within 5 min of conditioning. Record the bulk range (through) of the extinguisher as the range at the time corresponding to 50 percent of the effective discharge time that is if discharge time is 15 s. The range should be minimum up to 7.5 s.

NOTE — Where the range of effective discharge is difficult to determine visually, supplementary means, such as collection boxes for powders and condensing plates for liquefied gases may also be used.

7.3 Resistance to Temperature Changes (Type Test)

7.3.1 Requirements

Portable extinguishers shall be able to operate at temperatures within one of the temperature ranges given in 7.1 as indicated by the manufacturer and comply with the following requirements after being subjected to the conditions given in 7.3.2:

- a) shall operate as intended;
- b) commence discharge within 5 s of the opening of control valve; and
- c) not retain more than 10 percent of initial charge within the extinguisher following complete discharge.

7.3.2 Test Method

Subject four (two) extinguishers to the temperature cycles given in Table 2, two extinguishers to each cycle.

Operate the extinguisher within 5 min of its removal from the conditioning chamber.

Table 2 Temperature Cycles
(Clause 7.3.2)

Duration h (1)	Cycle 1 (2)	Cycle 2 (3)
24 ± 1	Store at minimum ¹⁾ stated temperature ($\frac{1}{2}$ °C)	Store at (55 ± 5)°C
24 ± 1	Store at (27 ± 5)°C	Store at (27 ± 5)°C
24 ± 1	Store at (55 ± 5)°C	Store at min ¹⁾ stated temperature ($\frac{1}{2}$ °C)

¹⁾ See 7.1 temperature range marked on the extinguisher.

The storage temperatures refer to the ambient temperature within the conditioning chamber. A liquid bath shall not be used.

The extinguisher is to be held in its normal working position and shall remain immobile for the duration of the test.

NOTE — For cartridge operated extinguishers the cartridge shall be pierced and the pressure allowed to build for 6 s before opening the control valve.

7.4 Retention of Charge

7.4.1 Routine Checks

7.4.1.1 Extinguishers and gas cartridges shall be designed so as to permit their charge to be checked at regular intervals when they are installed as per IS 2190.

7.4.1.2 The charge of the following shall be measured by weighing:

- All types of gas cartridges for extinguishers;
- Carbon dioxide extinguishers; and
- Stored-pressure extinguishers of various types including some clean agents in which a mass loss of 1 percent of total mass is accompanied by a pressure loss of not more than 10 percent of the service pressure at 27 ± 5°C.

7.4.1.3 The charge of stored-pressure extinguishers of types not covered in 7.4.1.2 (b) and (c) shall be checked by direct measurement of internal pressure at 27 ± 5°C. For this purpose, the extinguisher shall be fitted with a built-in pressure-indicating device, which can be checked for satisfactory operation.

A connection to which an independent pressure-measuring appliance can be attached may be used as the means for checking the built-in pressure-indicating device; in this case, a connection of this type shall be equipped with a pressure-retaining cap.

7.4.2 Retention of Charge Following Partial Discharge

7.4.2.1 Requirements

Fire extinguishers shall be fitted with a control valve

allowing the discharge of the extinguishing medium to be interrupted at any time.

The extinguisher shall be adequately resistant to leakage and the second pressure (or weight of contents as appropriate) shall be no less than 75 percent of the first, after interruption of the discharge as determined in 7.4.2.2.

7.4.2.2 Test method

Discharge a fully charged extinguisher for a period equal to half the time for total discharge and the control valve shall then be closed. Measure the internal pressure (or weight of contents as appropriate) and after a further 5 min with the valve having remained closed, measure the pressure (or weight of contents as appropriate) again.

7.4.3 Long-Term Leakage Test (Type Test)

7.4.3.1 Requirements for stored-pressure extinguishers

Stored-pressure extinguishers covered in 7.4.1.3 shall not leak at a rate exceeding 5 percent per annum of service pressure.

7.4.3.2 Requirements for gas cartridges and extinguishers checked by mass

Long-term leakage requirements are as follows:

- Stored-pressure extinguishers without a pressure gauge shall not leak at a rate exceeding 5 percent of its contents per annum or 50 g per annum, whichever is less [see 7.4.1.2 (c)];
- Gas cartridges shall not leak at a rate exceeding 5 percent of its contents per annum or 7 g per annum, whichever is less; and
- Carbon dioxide extinguishers shall not leak at a rate exceeding 5 percent of its contents per annum.

7.4.3.3 Test method

Check six samples for leakage after 30, 90 and 120 days. Any loss in pressure or contents at constant ambient temperature is an indication of a leak. Measure the leakage

in terms of weight or pressure loss, whichever is applicable.

7.5 Mechanical Resistance (Type Test)

7.5.1 Resistance to Impact

This test is intended to prove the resistance of the extinguisher, and particularly that of the head and fittings, to damage from falling objects or from impact with fixed surfaces.

7.5.1.1 Requirements

The extinguisher shall not release pressure in a potentially dangerous manner when tested in accordance with 7.5.1.2.

7.5.1.2 Test method

Condition an extinguisher, correctly charged and equipped with all the fittings which are subject to internal pressure in normal operation, for 18 h to the minimum working temperature (see 7.1) with a tolerance of $\pm 5^\circ\text{C}$, and maintain it at this temperature during the impact test described below.

If the extinguisher is of the gas cartridge type, fit the charged cartridge and activate the extinguisher with the control valve shut, so as to keep the extinguisher under pressure.

Conduct the impact test as follows:

Mount a steel cylindrical hammer, of 75 mm diameter and total mass of 4.0 kg with flat faces, vertically in loose guides so that it can drop freely through a height h (minimum height 300 mm) given by:

$$h = \frac{m}{20} \text{ and } h \geq 0.3$$

where

h = height, expressed in m; and

m = total mass of extinguisher, expressed in kg.

The extinguisher shall be placed on a rigid flat surface, protecting pressure gauge, in each of the following two positions in turn:

- in the normal upright position, with the longitudinal axis of the hammer coincident with the longitudinal axis of the valve; and
- lying on its side so that the valve rests on a rigidly fixed steel block.

In each of the above positions, submit the valve of the extinguisher to an impact by allowing the steel hammer to fall vertically onto it from the height h . The point of impact is to be examined.

7.5.2 Resistance to Vibrations (Type Test)

7.5.2.1 Test principle

An extinguisher shall be capable of withstanding exposure to the conditions of a vibration test without development of physical weakness, which would impair its normal operation.

7.5.2.2 Extinguisher mounting requirements

Extinguishers supplied with a wall hook or bracket not intended for use in vehicles shall be subjected to the test specified in 7.5.2.5.2.

Extinguishers supplied with a bracket for use in vehicles shall be subjected to the test specified in 7.5.2.5.3.

Extinguishers supplied with a bracket suitable for both general and vehicle use shall be subjected to the test specified in 7.5.2.5.3.

7.5.2.3 Test criteria

The test criteria are as follows:

- Following exposure to the vibration test the extinguisher shall comply with the discharge requirements specified in 7.2; and
- Physical failure of components which would require repair or replacement of the extinguisher and/or components before it can be returned to normal service shall be cause for rejection.

7.5.2.4 Mounting of the test specimen

Mount a fully charged extinguisher in an upright position. Mount extinguishers intended for use in vehicles in their intended bracket. Extinguishers not intended for use in vehicles may be tested without a bracket.

7.5.2.5 Test orientation

7.5.2.5.1 Axes of orientation

Subject the extinguisher to the vibration test specified in 7.5.2.5.2 or 7.5.2.5.3 in each of the three rectilinear axes in the following order: horizontal, lateral, and vertical.

7.5.2.5.2 General extinguishers

The vibration applied shall have the following parameters:

Frequency : 40 Hz

Amplitude : 0.25 ± 0.03 mm

Duration : 2 h (in each orientation specified in 7.5.2.5.1)

7.5.2.5.3 Vehicle extinguishers

Subject the vehicle extinguishers to the following tests:

- Subject the extinguisher to the variable frequency and amplitude specified below in each orientation specified in 7.5.2.5.1.

Frequency, Hz	Amplitude, mm
10 to 19	0.75 ± 0.08
20 to 39	0.50 ± 0.05
40 to 60	0.25 ± 0.03

Vibrate the extinguisher for 5 min at each frequency and increase the frequency at discrete intervals of 2 Hz, and

- b) Vibrate the extinguisher for 2 h at the frequency which produced the maximum resonance as determined in (a) above or if no resonance is observed subjected to the test specified in 7.5.2.5.2.

Complete the tests specified in (a) and (b) above in one plane before making tests in the next plane.

7.6 Resistance to Corrosion (Type Test)

7.6.1 External Corrosion Test

Subject complete and fully charged extinguishers, including their mounting bracket and wall hook, to a salt spray test as defined in IS 6910 for a period of 240 h. Following a drying period of at least 24 h at room temperature, carefully wash the extinguisher to remove any salt deposits. Test two samples that is either two of the same size or one sample each of two different sizes from the same family.

At the conclusion of the test the following requirements shall be satisfied:

- a) The mechanical operation of all working parts shall be unimpaired;
- b) The minimum effective discharge time and method of operation shall comply with requirements specified;
- c) The pressure gauge, if one is fitted, shall remain functional and watertight; and
- d) There shall be no corrosion of the metal of the extinguisher body; discolouration/superficial corrosion of non-ferrous metals is acceptable, but galvanic corrosion between dissimilar metals shall not be permitted.

7.6.2 Internal Corrosion Test for Extinguishers Using Water-Based Media (Type Test) and Gaseous Extinguishers

Subject two extinguishers, charged in accordance with the manufacturer's filling instructions, eight times to the temperature cycle defined in Table 3.

On completion of the eight temperature cycles, cut each body into two sections in a manner sufficient to permit internal examination. Disregard detachment of any

Table 3 Temperature Cycle
(Clause 7.6.2)

Stage	Duration h	Temperature, °C
(1)	(2)	(3)
1	27 ± 5	1)
2	≥ 27	27 ± 5
3	27 ± 5	60 ± 2
4	≥ 27	27 ± 5

The temperature refers to the ambient temperature of the conditioning chamber. A liquid bath shall not be used. The duration of any one complete cycle shall not exceed 120 h.

¹⁾ The lowest temperature marked on the extinguisher ± 2°C (see 7.1).

protective coating local to the plane of section. There shall be no visible signs of corrosion of the metal nor detachment, cracking or bubbling of any protective coating. There shall be no visible change in the colour of the extinguishing media other than that resulting from the thermal cycling in case of water based media only.

NOTE — Allowance should be made for a change of colour that occurs naturally due to the temperature changes. It is recommended that two samples of the agent be stored in closed glass containers and subjected to the same cycles as the extinguishers in order to establish a reference sample.

7.7 Tapping Test (Type Test)

7.7.1 Requirements

Portable extinguishers shall comply with the following requirements after being subjected to the conditioning specified in 7.7.3 :

- a) Shall operate satisfactorily;
- b) Commence discharge within 5 s of the opening of the control valve; and
- c) Not retain more than the following percentage of initial charge within the extinguisher following complete discharge:
 - 1) powder: 15 percent
 - 2) all other media: 10 percent.

7.7.2 Test Apparatus

7.7.2.1 Compaction machine, designed to accept only one extinguisher at a time which shall be raised by rod and guided by castors.

The plate supporting the extinguisher shall be of steel 300 ± 5 mm square and 60 ± 1 mm thick. Figure 1 is an example of an acceptable test apparatus.

Observe the following points:

- a) Ensure that the rod is adjustable as to adjust to the extinguisher base;
- b) Ensure that the rod can move freely in the guide castors; and
- c) Extinguisher shall also be guided without constraint.

7.7.3 Test Method

An extinguisher in a normally charged condition shall be held in the vertical position and dropped vertical 500 times from a height of 15 mm at a frequency of 1 Hz onto a rigid horizontal steel plate.

The extinguisher is to be removed from the test apparatus with a minimum amount of agitation, held in its normal working position, and operated.

NOTE — For cartridge extinguishers, the cartridge shall be pierced and the pressure allowed to build for 6 s before opening of the control valve.

7.8 Intermittent Discharge Test

7.8.1 An extinguisher conditioned at its minimum operating temperature $\pm 2^\circ\text{C}$ and at $55 \pm 5^\circ\text{C}$ shall operate in such a manner that no more than 1 s elapses from the time the control valve is opened until the extinguishing media starts to discharge. Additionally, at the end of discharge, the extinguisher shall not retain more than the following percentages of its original charge:

- a) powder: 15 percent; and
- b) all others: 10 percent.

7.8.2 Condition a correctly charged extinguisher at each of the specified temperatures for a min of 18 h. Operate the extinguisher intermittently by opening and closing the valve in cycles of 2 s 'open' and 2 s 'closed' until the end of discharge is reached.

7.8.3 For cartridge-operated extinguishers, pierce the cartridge and allow the pressure to build for 6 s before

opening the control valve.

8 PERFORMANCE REQUIREMENTS FOR TEST FIRES

8.1 Rating Suitability for the Various Classes of Fire

8.1.1 Class A

The rating of extinguishers recommended as suitable for Class A fires shall be determined using the method described in 8.3. The rating shall be based on the amount of extinguishing medium used to extinguish the fire of maximum size under the conditions of the test. This amount shall be no less than the appropriate minimum value given in Table 4.

8.1.2 Class B

The rating of extinguishers recommended as suitable for Class B fires shall be determined using the method give in 8.4. The rating shall be based on the amount of extinguishing medium used to extinguish the fire of maximum size under the conditions of the test. This amount shall be no less than the appropriate minimum value given in Table 5.

8.1.3 Class C

There are no tests requirements for the performance of extinguishers against Class C fires included in this standard, suitability for use against Class C may be claimed for Class B or Class AB powder extinguishers only.

8.1.4 Class D

Extinguishers recommended as suitable for Class D fires shall extinguish the appropriate test fire or fires when tested as described in 8.5.

NOTE — Extinguishers suitable for Class D fires are usually not suitable for use on fires of other classes. Specialized media and applicators are typically used.

Table 4 Amount of Extinguishing Medium Used to Obtain a Minimum Class A Rating of Extinguishers
(Clause 8.1.1)

Powder kg (1)	Extinguishing Medium Content (Charge)		Minimum Class A Rating (4)
	Water/Foam Water with Additives (2)	Clean Agent kg (3)	
1 ≤ 2	1 ≤ 6	1 ≤ 6	1 A
2 < 1 ≤ 4	6 < 1 ≤ 10	6 < 1 ≤ 8	2 A
4 < 1 ≤ 6	1 > 10	1 > 8	3 A
6 < 1 ≤ 9			4 A
1 > 9			6 A

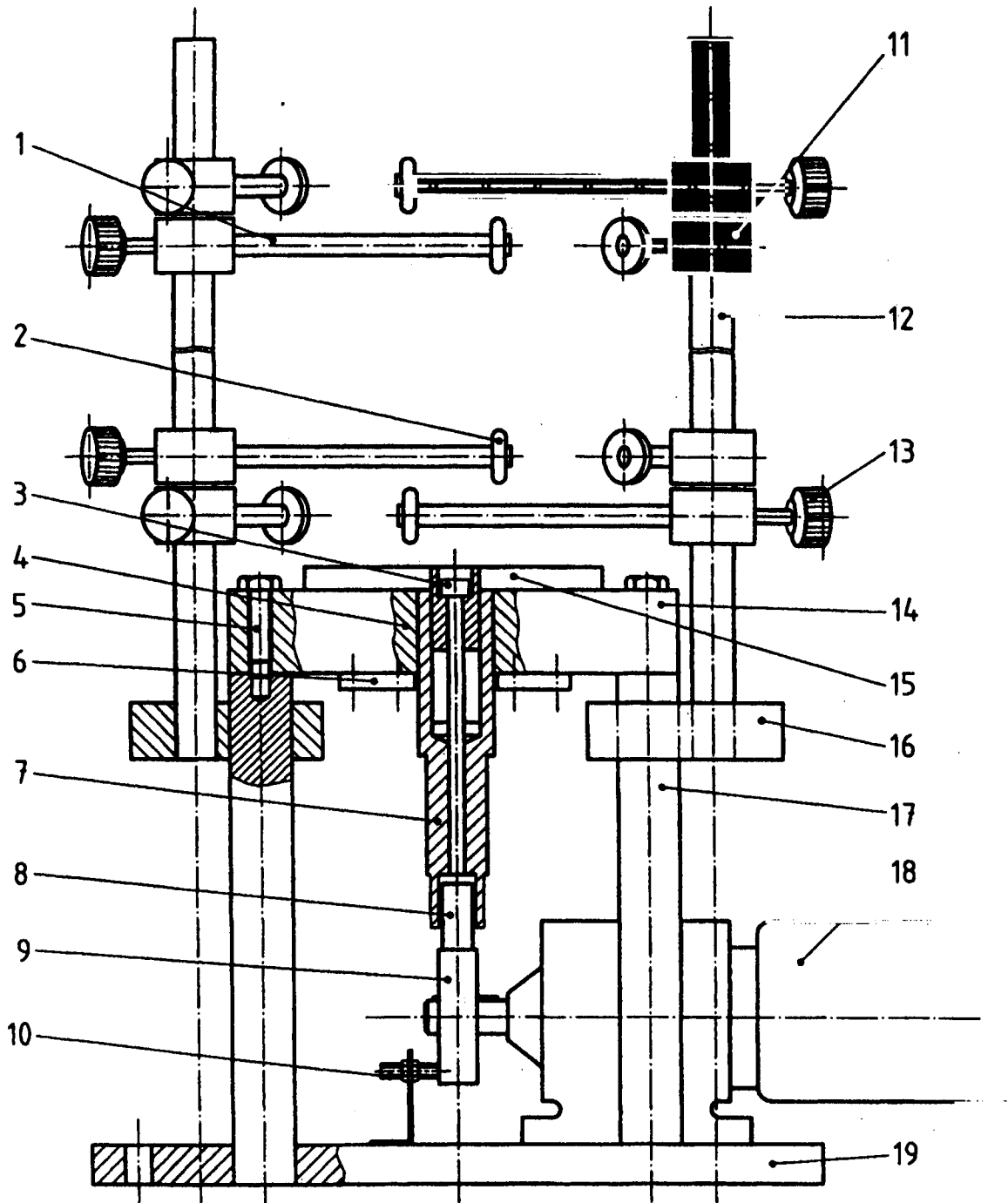

1A GENERAL DIAGRAM

Key

- | | | |
|----------------------------|-----------------------|---------------------------------|
| 1. Castor support axis | 8. Castor | 15. Adjusting block |
| 2. Castors | 9. Cam | 16. Support axes |
| 3. Cl + C, M12 - 190 screw | 10. Inductive pick-up | 17. Plate support axis |
| 4. Push-nut extinguisher | 11. Rotation guidance | 18. Flender-Himmel geared motor |
| 5. H, M16-90 screw | 12. Axes | 19. System support plate |
| 6. Plates | 13. Castor nut | |
| 7. Piston | 14. Support plate | |

FIG. 1 TAPPING MACHINE — *Continued*

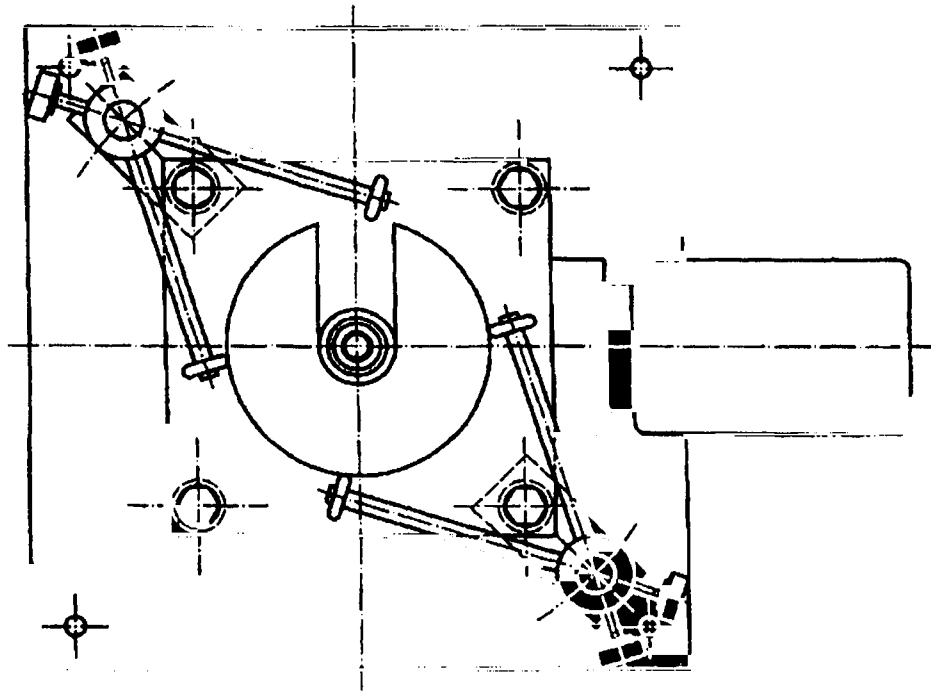

1B View from Above

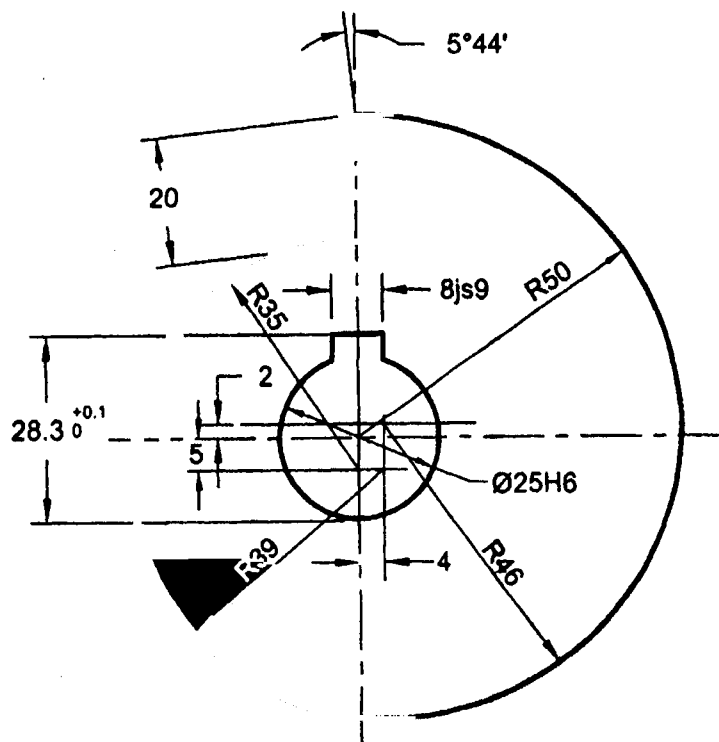

All dimensions in millimetres.

1C Side View

FIG. 1 TAPPING MACHINE

**Table 5 Amount of Extinguishing Medium Used to Obtain Minimum Class B Rating of Extinguishers
(Clause 8.1.2)**

Extinguishing Medium Content (Charge)				Minimum Class B Rating
Powder kg	Carbon Dioxide kg	Clean Agent kg	Foam or Water with Additives l	
(1)	(2)	(3)	(4)	(5)
1 ≤ 2	1 ≤ 2	1 ≤ 2	5	8B
1 ≤ 2	1 ≤ 2	1 ≤ 2	5	13B
2 < 1 ≤ 3	2 < 1 ≤ 5	2 < 1 ≤ 4	9	21B
3 < 1 ≤ 4	1 > 5	4 < 1 ≤ 6	9	34B

NOTE — At present the clean agent approved internationally for this purpose are HFC and HCFC.

8.2 Test Fires — General

8.2.1 Operator's Clothing

To carry out these tests the operator shall wear suitable protective clothing including shoes, helmet, visor, gloves etc.

NOTE — Attention is drawn to the necessity for taking precautions to safeguard the health and safety of personnel conducting the tests against the risk of fire and inhalation of smoke and any toxic products of combustion, and compliance with the national legislation which may apply concerning the health and safety of the extinguisher operator and other personnel.

8.2.2 Requirements for Extinguishment

Test fires shall be regarded as extinguished if:

Class A — All flames are extinguished. There shall be no flames visible 10 min after complete discharge of the extinguisher. The appearance of non-persistent flames during the 10 min period shall be ignored. Non-persistent flames are defined as less than 50 mm in height and less than 1 min duration; if the Class A crib collapses during the test, it shall be considered void and a fresh test carried out.

Class B — All flames are extinguished.

8.2.3 Test Extinguishers and Method of Use

Use extinguishers filled and charged according to the manufacturer's instructions. It is permitted, at the operator's discretion, to operate a gas cartridge extinguisher so as to allow the operating pressure to increase in the body prior to discharge.

8.2.4 Test Schedule (Type)

The basic schedule of testing is a set of three fires. Class A or Class B rating is achieved by extinguishing two out of three fires of the same size. Class D suitability for a

particular metal or form of metal is established by extinguishing either the first fire of the set, or if this is not extinguished, extinguishing the second and third test fires.

A set comprises fires consecutively carried out and the result of any particular test fire is not to be disregarded. Each set is to be completed before another is started. For Class A and Class B fires, a set is completed either when all three test fires are carried out or when the first two test fires are both successful or both unsuccessful. For Class D fires, a set is complete when the first test is successful, or when the first and second fires are both unsuccessful, or when all three are carried out.

8.3 Class A Test Fire

8.3.1 Location

Conduct the tests in an essentially draught-free room having adequate volume and ventilation to ensure the necessary supply of oxygen and reasonable visibility for the period of the test.

Air inlet openings at or near ground level as given in Table 6, with a flue area of 4.5 m² have been found to provide adequate ventilation.

NOTES

1 For example, it has been established that a room having a ceiling height of approximately 3 m and size 7 m × 7 m for class upto 2A and 34 B and of size 15 m × 15 m for higher classes with adjustable inlet openings near the four corners is suitable for these purposes. The room should have smoothly finished concrete floor.

2 This test may be carried out by putting 3 m high mild steel sheet enclosing three sides till infrastructure is developed for indoor test facilities.

8.3.2 Construction

The test fire consists of a crib made of pieces of wood. The pieces of wood forming the outside edges of the crib may be stapled or nailed together to provide strength.

Table 6 Example of Typical Air Inlet Sizes for Ventilation of Class A Test Fires
(Clause 8.3.1)

Classification and Rating	Air Inlet Opening Surface Area m ²
(1)	(2)
1A	0.10
2A	0.10
3A	0.15
4A	0.20
6A	0.30

Construct the crib on two 63 mm × 38 mm angle irons or other similar and appropriate supports, placed on concrete blocks or support frame so as the height of the supports above the floor is 400 ± 10 mm.

Stack the pieces of wood in the appropriate arrangement

specified in Table 7. Stack each layer of the pieces of wood at right angles to the layer below. Stack individual pieces of wood on each layer with even spacing and in the form of a square with sides equal to the length of the piece of wood (see Fig. 2).

Use pieces of wood of *Pinus Sylvestris*, or of other wood which can be shown to be equivalent, of appropriate length as specified in Table 7 and of square cross-section with sides of 39 ± 1 mm, a moisture content of 10 percent to 14 percent by mass (dry basis).

NOTES

- 1 Wood is considered to be equivalent if the rating achieved using wood that is not more than that achieved when *Pinus Sylvestris* is used. *Cryptomeria Japonica* may be preferred in India.
- 2 Determine the moisture content of the pieces of wood using commercially available instruments which measure electrical conductivity between needle probes pushed into the sticks or other suitable method. Some variation in reading may be obtained due to structural variation of the timber and the direction of the grain. Calibrate the instrument by determination of moisture content in accordance with IS 1708 (Part 1).

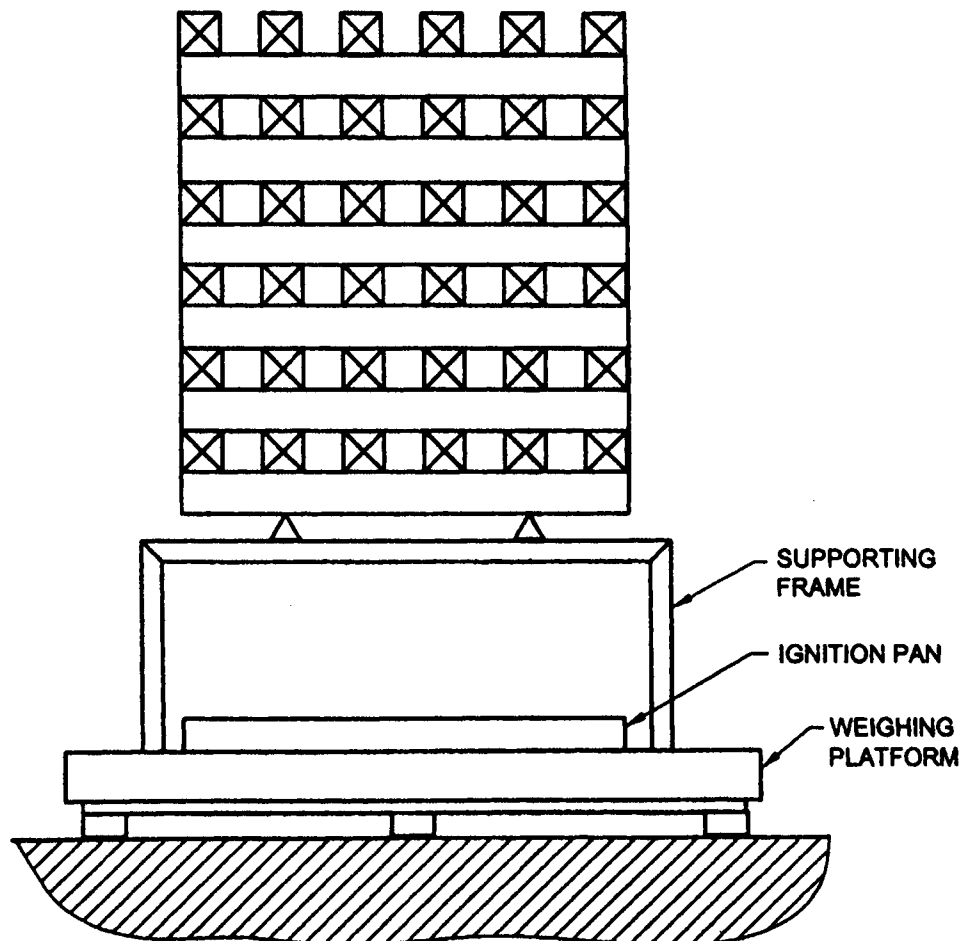

FIG. 2 CRIB FIRE

Table 7 Wood Crib Construction
(Clause 8.3.2)

Class A Rating	Number of Pieces of Wood	Length of Pieces of Wood mm	Arrangement of Pieces of Wood
(1)	(2)	(3)	(4)
1A	72	500	12 layers of 6 pieces of wood
2A	112	635	16 layers of 7 pieces of wood
3A	144	735	18 layers of 8 pieces of wood
4A	180	800	20 layers of 9 pieces of wood
6A	230	925	23 layers of 10 pieces of wood

NOTE — If necessary in the future, it is intended that this table be extended to include larger test fires. These will be constructed on the same principles as those now listed. Each Class A rating is designated by a number in a series which is proportional to the mass of wood contained in a crib. All cribs are cubic with the volume of the open space approximately equal to the volume of the wood.

8.3.3 Procedure

Place an ignition pan of appropriate size as specified in Table 8 on the floor under the crib. Level the pan as far as is possible and add sufficient water to cover the base. Pour the appropriate volume of fuel (as specified in Table 8) into the pan. Ignite the fuel. Remove the pan once the liquid has been consumed.

Allow the crib to burn until its mass is reduced to 55 ± 2 percent of its original mass. The mass loss may be determined directly or by other methods which can be demonstrated to provide equivalent correlation.

NOTE — This will take 6 min to 10 min. Either monitor the mass continuously or determine the time by a preliminary test or tests, extinguishing the fire(s) and measuring the mass and core diameters making adjustments as necessary.

Apply the discharge of the extinguisher to the test fire, initially to the front. Reduce the distance of attack and apply the discharge to the top, bottom, front or either side but not the back of the crib, at will. Maintain all devices for controlling the flow of the extinguishing media in the position for maximum discharge to ensure a continuous jet.

8.4 Class B Test Fire

8.4.1 Location

Carry out test fires up to and including 13B indoors. Carry out test fires larger than 13B indoors or outdoors but with the wind speed not exceeding 3 m/s. Do not carry out tests outdoors when rain, snow or hail is falling.

8.4.2 Construction

Class B test fires utilize a range of welded-sheet-steel cylindrical trays (dimensions given in Table 9). The sides

Table 8 Wood-Crib Ignition Arrangement
(Clause 8.3.3)

Class A Rating	Ignition Pan Size mm	Heptane Charge ¹⁾ l
(1)	(2)	(3)
1A	400 × 400 × 100	1.1
2A	535 × 535 × 100	2.0
3A	635 × 635 × 100	2.8
4A	700 × 700 × 100	3.4
6A	825 × 825 × 100	4.8

¹⁾ See 8.4.3.

are vertical. The base of the trays are set horizontal and level with the surrounding ground.

NOTE — Reinforcement of the base of the larger test fire trays will be necessary to minimize distortion. In such cases it will be necessary to ensure that the underside of the trays are not exposed to the atmosphere.

Details of Class B test fires are given in Table 9. Each test fire is designated by a number followed by the letter B.

8.4.3 Fuel

Use an aliphatic hydrocarbon having an initial boiling point of not less than 88°C and a final boiling point of not more than 105°C.

NOTE — Typical fuels meeting this requirement are *n*-heptane and certain solvent fractions sometimes referred to as commercial heptane.

8.4.4 Procedure

8.4.4.1 Add the appropriate volume of water and heptane specified in Table 9. Add additional water to compensate for distortion of the base so that all points are covered, subject to a maximum liquid depth of 50 mm and a minimum heptane depth of 15 mm at any point.

8.4.4.2 For the testing of foam and clean agent extinguishers use fresh fuel for each test.

8.4.4.3 When testing powder extinguishers it shall be demonstrable that the rating can be achieved using fresh fuel.

8.4.4.4 Ignite the fuel

8.4.4.5 Permit the fuel to burn freely for a minimum of 60 s before operating the extinguisher.

8.4.4.6 Operate the extinguisher and apply the extinguishing medium to the test fire.

NOTES

1 The extinguisher may be discharged continuously or in intermittent bursts at the discretion of the operator. The operator

Table 9 Dimensions of Class B Test Fires
(Clause 8.4.2)

Classification	Minimum Discharge of Extinguishers	Volume of Liquid ¹⁾ l	Dimensions of Test Fire Tray			
			Diameter ²⁾ mm	Internal Depth ¹⁾ mm	Minimal Thickness of Walls mm	Approximate Surface Area of Fire m ²
(1)	(2)	(3)	(4)	(5)	(6)	(7)
8B ³⁾	—	8	570 ± 10	150 ± 5	2.0	0.25
13B ³⁾	—	13	720 ± 10	150 ± 5	2.0	0.41
21B	8	21	920 ± 10	150 ± 5	2.0	0.66
34B	8	34	1 170 ± 10	150 ± 5	2.5	1.07

NOTE — Each test fire is designated by a number in a series in which each term is equal to the sum of the two preceding terms (this series is equivalent to geometric progression having a common ratio of about 1.62). Test fires larger than those given may be constructed following the rules of this geometric progression.

¹⁾ One-thirds water and two-thirds heptane.

²⁾ Measured at rim.

³⁾ This fire size is for a low-temperature fire test only.

may move round the fire in order to obtain the best results.

2 For reasons of safety the operator shall not reach over the edge of the tray, and at no time shall the operator onto or into the tray.

8.5 Class D Test Fire

8.5.1 General

The extinguishment of these test fires is based on the use of a portable extinguisher having a nominal charge 10 kg of media. Extinguishers having a lesser charge shall be tested using a proportionally reduced quantity and surface area of fuels. Extinguishers with a charge of less than 8 kg shall not be allowed.

WARNING — Some extinguishing media used for Class D fires are toxic (for example, barium chloride BaCl₂) and/or may react with the burning metal to produce materials which are toxic or otherwise hazardous (for example, phosphates which react to form metal phosphides, which are decomposed by water to produce phosphine, PH₃, a spontaneously flammable gas).

Before carrying out these tests, establish procedures to protect personnel and to safely dispose of residues from test fires.

Conduct the tests in an essentially draught-free room having adequate volume and ventilation to ensure the necessary visibility for the period of the test.

There are no numerical components for Class D ratings. The type of combustible metal for which the extinguisher is applicable and the area, depth, and other characteristics of the fires which may be controlled and extinguish are to be summarized on the extinguisher nameplate and described in the manufacturer's installation instructions.

8.5.2 Metal Chip or Turning Fires

8.5.2.1 Construction

The fires consist of a bed of the metal fuel 600 mm × 600 mm square positioned centrally on a steel base-plate 1 m × 1 m square and 5 mm thick. Use a removable metal or wood frame to build the bed.

For ignition, use a device such as a gas/oxygen torch which will ignite the metal within 30 s.

8.5.2.2 Fuel

Carry out four series of tests using:

- magnesium Al alloy;
- magnesium alloy with cutting oil;
- reagent-grade magnesium; and
- reagent-grade magnesium with cutting oil.

8.5.2.3 Procedure

For each test, prepare the fuel bed in the removable metal or wood frame. Level the surface of the fuel using a rake or straight-edged board. Remove the frame.

Apply the igniting torch to the centre of the fuel bed, removing the torch after 25 s to 30 s.

Allow the fire to spread until it is estimated that either 25 percent of the fuel is burning or the fire covers 50 percent of the fuel bed surface, whichever occurs sooner. The extinguisher may then be discharged onto the fire at the operator's discretion, continuously or intermittently, according to the manufacturer's instructions.

Check that fuel is not scattered off the base plate during the attack.

After discharge is completed, allow the fire bed to remain undisturbed for the period of time recommended by the extinguisher manufacturer, or if no time is recommended, for 60 min. Examine the fuel bed and check that the fire is completely extinguished and that more than 10 percent of the original metal fuel remains.

8.5.3 Metal Powder or Dust Fires

8.5.3.1 Construction

Construct the fires in the same manner as the metal chip fires (see 8.5.2.1).

8.5.3.2 Fuel

Use magnesium powder containing not less than 99.5 percent magnesium. All the particles shall pass a 387 μm sieve and no less than 80 percent of the powder shall be retained on a 150 μm sieve. Carry out two series of tests one series using 11.0 ± 0.1 kg of dry metal and one series using 9.9 ± 0.1 kg of the metal plus 1.1 ± 0.1 kg of the oil specified in 8.5.2.2 for each fire.

8.5.3.3 Procedure

Carry out the tests using the same procedure as the metal chip fires in 8.5.2.3.

8.5.4 Shallow Liquid Metal Fires

8.5.4.1 Construction

Two series of tests are carried out. One series will be carried out in a circular steel pan approximately 540 mm in diameter and 150 ± 10 mm deep, fitted with a tight fitting cover, and with suitable means of handling, moving and tipping, and with a horizontal thermocouple to be positioned in the approximate centre of the pan. This pan is also used to melt the metal fuel, using a heat source which does not allow any flames to extend beyond the base of the pan. In the second series, melted burning fuel is poured on a tray approximately 600 mm \times 600 mm square and having a depth of (155 ± 5) mm.

8.5.4.2 Fuel

Use (1.36 ± 0.04) kg of sodium for the spill fire, and for the pan fire sufficient sodium to give a melted fuel depth of (25 ± 1) mm.

8.5.4.3 Procedure

8.5.4.3.1 Spill fire

Position the square tray on a flat level surface. Heat the metal in the covered melting pan until the temperature is $520 \pm 10^\circ\text{C}$. Carefully remove the cover, allowing the liquid

metal to ignite as air enters. Stop heating when the temperature reaches $550 \pm 10^\circ\text{C}$ and pour the burning liquid fuel into the square tray. As soon as the burning fuel has spread across the tray the fire can be attacked at the operator's discretion using the manufacturer's recommended extinguishing techniques.

After the discharge is completed, allow the fire tray to remain undisturbed for the period of time recommended by the manufacturer, or if no time is recommended for 4 ± 0.5 h. Then using a suitable temperature measuring device check that the fuel/extinguishing medium mixture in the tray is at a temperature no more than 27°C above the ambient air temperature and that more than 10 percent of the original fuel remains.

8.5.4.3.2 Pan fire

This test is carried out entirely in the melting pan.

Melt the fuel and allow it to ignite generally as described in 8.5.4.3.1. When the temperature reaches $550 \pm 10^\circ\text{C}$ move the pan from the heat source and place it on a level floor, where it may be attacked at the operator's discretion, using the manufacturer's recommended extinguishing techniques. After discharge is completed, follow the procedure described in 8.5.4.3.1.

8.5.5 Simulated Casting Fire

8.5.5.1 General

The fire consists of melted metal poured into the steel tray described in 8.5.4.1 positioned on a level surface with an obstruction, formed from a 50 ± 5 mm length of steel I-beam, 100 mm deep and 100 mm wide, positioned centrally in the tray, on its side in the attitude of an arch, as shown in Fig. 3.

8.5.5.2 Fuel

Use 11.3 ± 0.1 kg of the magnesium alloy described in 8.5.2.2.

8.5.5.3 Procedure

Heat the magnesium alloy in the covered melting pan described in 8.5.4.1 until completely melted. Carefully remove the cover and continue to heat until the temperature reaches $650 \pm 10^\circ\text{C}$ above the melting point if the fuel does not ignite spontaneously use the gas torch (see 8.5.2.1) to ignite it. Pour the fuel into the tray, but not directly over the obstruction. As soon as the burning fuel has spread across the tray, the fire can be attacked at the operator's discretion using the manufacturer's recommended extinguishing techniques.

After discharge is completed follow the procedure described in 8.5.2.3.

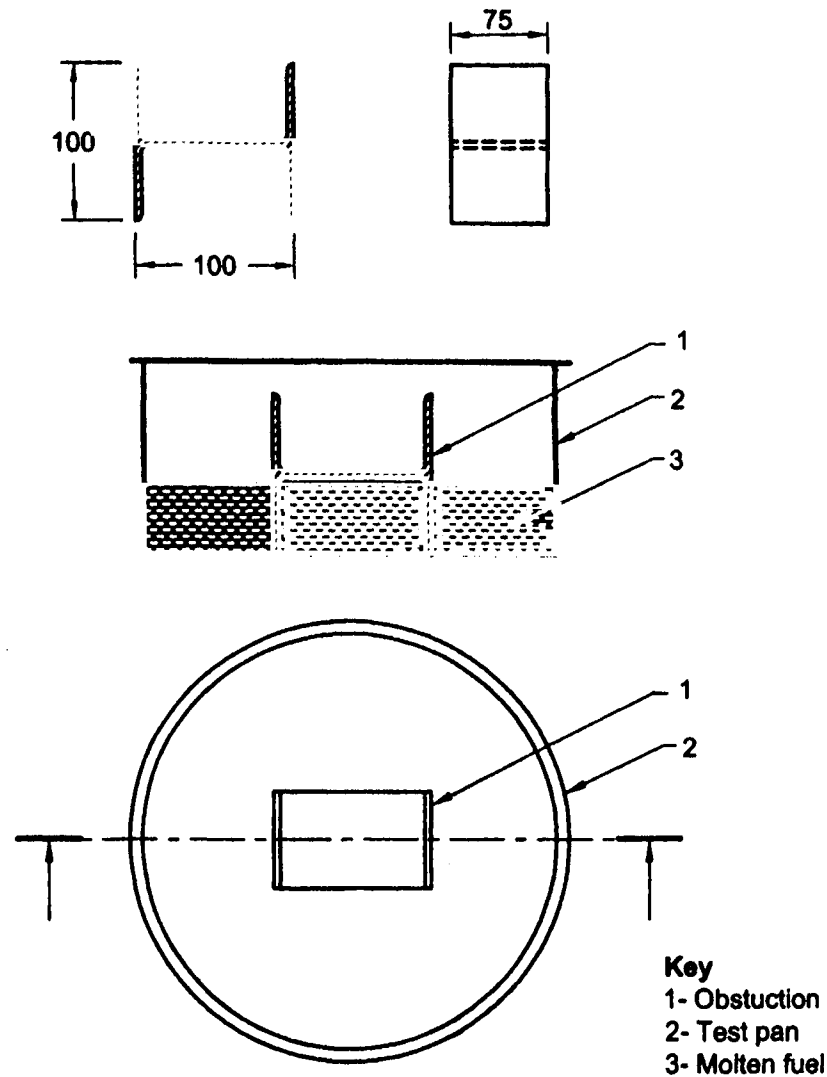

8.6 Electrical Conductivity of Extinguisher Discharge (Type Test)

8.6.1 Water-Based Extinguishers

Water-based extinguishers that are marked as suitable for use on energized electrical equipment fires shall not pass a current of more than 0.5 mA when tested as described in 8.6.3.

8.6.2 Requirements

Test the extinguisher in accordance with 8.6.3. When the extinguisher is in operation and the metallic plate is live, the current between the handle or the nozzle and earth and between earth and the extinguisher shall be no more than 0.5 mA at any time during the complete discharge duration of the extinguisher.

8.6.3 Test for Electrical Conductivity

Hang a metal plate, of dimensions $1\text{ m} \pm 25\text{ mm} \times 1\text{ m} \pm 25\text{ mm}$, vertically from insulating supports. Connect the plate to a transformer so that an alternating voltage of $36 \pm 3.6\text{ kV}$ is established between the plate and earth. The impedance of the circuit should be such that when a voltage equal to 10 percent of the normal primary voltage is applied to the primary, and the secondary is short-circuited, the current in the secondary is not less than 0.1 mA.

Mount the extinguisher on an insulating support with the nozzle fixed 1 m from the centre of the plate, at right angles to it and directed towards it. Connect the extinguisher to the earth. In the case of an extinguisher with a hose connect it to the earth by connection at the nozzle or in the case of

an extinguisher not fitted with a hose, by connection at the handle.

Measure any current flowing between the extinguisher and the earth when the plate is live and the extinguisher discharging.

9 CONSTRUCTION REQUIREMENTS

9.1 High-Pressure Extinguishers

Extinguishers with a service pressure greater than 19 bar (CO_2) shall have concave base. For carbon dioxide extinguishers, in case of steel body, it shall conform to IS 7285 and in case of aluminium body, it shall conform to IS 15660. Gas cartridge shall conform to IS 4947. The CO_2 gas cartridge shall be of minimum 60 g.

9.2 Low-Pressure Extinguishers

9.2.1 General Requirements

9.2.1.1 These requirements are applicable to extinguishers having a service pressure (P_s) not exceeding 19 bar.

9.2.1.2 A portable extinguisher with a charge exceeding 3 kg shall be constructed such that it can be stood vertically without extra support. Gas cartridge shall conform to IS 4947.

9.2.1.3 The manufacturer shall ensure that the welds show continuous penetration with no deviation in the weld. Welds and brazed joints shall be free from defects which are prejudicial to the safe use of the cylinder.

9.2.1.4 Parts attached to the body of the extinguisher shall be manufactured and fitted in a way that minimize concentrations of stress and corrosion risks. In the case of welded and brazed parts, the metal shall be compatible with the cylinder material.

9.2.1.5 The cylinder manufacturer shall obtain the certificate for the cast analysis of material supplied.

9.2.1.6 Where plastic components are threaded into metallic parts they shall be designed to minimize the possibility of cross-threading. This shall be accomplished by the use of coarse threads of less than 5 threads/cm or by the use of square-cut threads.

9.2.1.7 Extinguishers which are free standing shall either be fitted with a means to raise the pressure-retaining part of the body at least 5 mm above the floor, or the thickness of metal in the lowest pressure retaining part or parts of the body shall not be less than 1.5 times the minimum thickness of the cylindrical part of the body.

9.2.1.8 Determination of maximum service pressure (P_m)

9.2.1.8.1 Conduct the test on a minimum of three extinguishers conditioned at 55 °C for 18 h.

9.2.1.8.2 For stored-pressure type extinguishers, determine the pressure immediately after taking each extinguisher out of the oven. For cartridge-operated type extinguishers, remove each extinguisher from the oven and activate the cartridge immediately.

9.2.1.8.3 For each type of extinguisher the highest pressure observed during 9.2.1.8.2 is recorded as the maximum service pressure (P_m).

9.2.2 Burst Test

9.2.2.1 Fill the extinguisher with a suitable liquid and increase the pressure at a rate not exceeding (20 ± 2) bar/min until the minimum burst pressure (P_b) is achieved. Maintain this pressure for 1 min without the cylinder rupturing. Increase the pressure until rupture occurs. The minimum burst pressure (P_b) shall be $2.7 \times P_m$ but in no case less than 55 bar.

9.2.2.2 The bursting test shall not cause the cylinder to fragment.

9.2.2.3 The break shall not show any sign of brittleness, that is the edges of the break shall not be radial but shall be slanting in respect of a diametrical plane and shall exhibit a reduction in area over their entire thickness.

9.2.2.4 The break shall not show any characterized defect in the metal.

9.2.2.5 The break shall not occur in the weld at a pressure less than $5.4 \times P_m$ or 8 MPa (80 bar), whichever is greater.

9.2.2.6 During the burst test, no parts shall be ejected from the extinguisher.

9.2.3 Crushing Test (Type Test)

9.2.3.1 Crush a minimum of three extinguishers perpendicularly to their longitudinal axis, and at their midpoint using two 25 mm thick mandrels with a radius at their apex of 12.5 mm and a width sufficient to extend beyond the sides of the extinguisher (see Fig. 4). Crush the cylinder over a period between 30 s and 60 s. In the case of extinguishers with a longitudinal weld place, the weld seam at 90° to the support lines. For extinguishers with central transverse welds, apply the mandrel at 45° to the weld seam.

9.2.3.2 After the crushing test, fill the extinguishers with water and increase the pressure to test pressure (P_t). The extinguishers shall not exhibit any cracks or leaks.

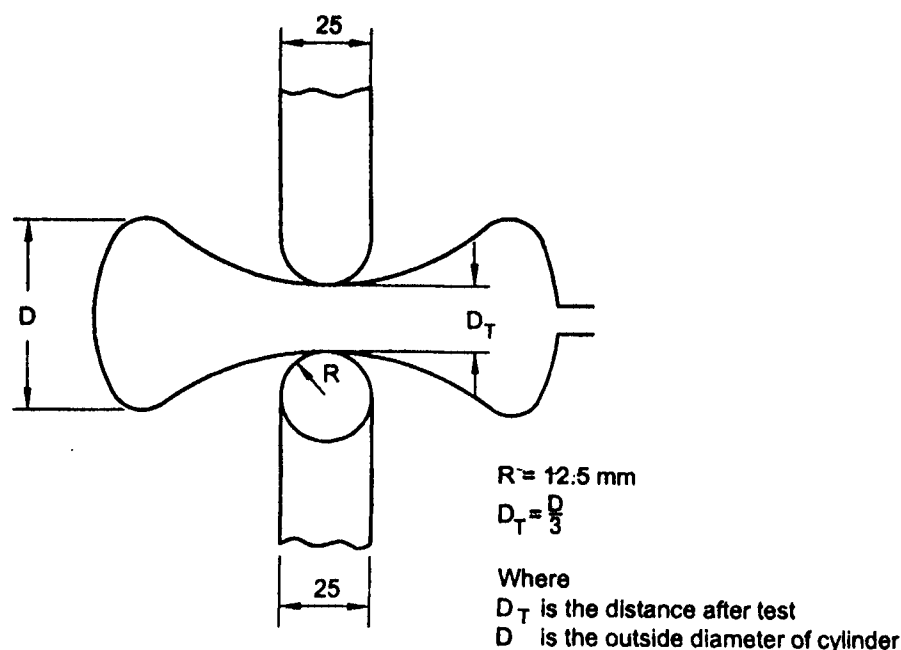

FIG. 4 CRUSHING TEST

9.2.4 Permanent Volumetric Expansion Test (Type Test)

It is only for high pressure cylinders. There shall be no permanent expansion in excess of 10 percent of the total expansion of the cylinder when subjected to the test pressure (P_t) for 30 s. For cylinders that have been proof-pressure tested prior to the deformation test, test pressure shall be increased by 10 percent.

NOTE — An acceptable test apparatus is the water jacket test however other methods are also acceptable.

9.2.5 Pressure Cycling Test (Type Test)

A minimum of two cylinders shall be tested.

An extinguisher cylinder shall sustain, without rupture, 5 000 cycles from 0 to the test pressure (P_t) and back to 0 at the rate of 6 cycles/min. At the conclusion of testing, the cylinder shall be subjected to and comply with the burst test.

9.2.6 Welded Low Carbon Steel Cylinder

9.2.6.1 The cylinder material shall be capable of being welded and shall contain a maximum of 0.25 percent carbon, 0.05 percent of sulphur and 0.05 percent of phosphorous.

9.2.6.2 Filler material shall be compatible with the steel to give welds with properties equivalent to those specified for the base sheet.

9.2.6.3 The cylinder shall have a measured thickness

greater than the minimum thickness given by the following formula but in no case less than 0.70 mm:

$$S = \frac{D}{300} + k$$

where

S = minimum thickness, expressed in mm;

D = outside diameter of the cylinder or, for non-cylindrical bodies, the greatest external diagonal of the extinguisher body, expressed in mm; and

k = coefficient equal to:

0.45 for $D \leq 80$;

0.50 for $80 < D \leq 100$; and

0.70 for $D > 100$.

9.2.7 Stainless Steel Cylinders

9.2.7.1 Stainless steel domes and bottoms shall be drawn from fully annealed stock.

9.2.7.2 Only austenitic stainless steel having a maximum carbon content of 0.03 percent shall be used.

9.2.7.3 The cylinder shall have a minimum measured wall thickness greater than the minimum wall thickness given by the following formula but in no case less than 0.64 mm:

$$S = \frac{D}{600} + k$$

where

- S = minimum wall thickness, expressed in mm;
- D = outside diameter of the cylinder or, for non-cylindrical bodies, the greatest external diagonal of the extinguisher body, expressed in mm; and
- k = 0.3.

9.2.8 Aluminium Cylinders

9.2.8.1 Aluminium cylinders shall be of a seamless construction.

9.2.8.2 Aluminium cylinders shall have a measured wall thickness greater than or equal to the minimum thickness given by the following formula but in no case less than 0.71 mm:

$$S = \frac{D}{80} + k$$

where

- S = minimum thickness, expressed in mm;
- D = outside diameter of the cylinder, or for non-cylindrical bodies the greatest external diagonal of the extinguisher body, expressed in mm; and
- k = coefficient equal to:
 - 0.2 for $D \leq 100$ mm;
 - 0.3 for $D > 100$ mm.

9.3 Carrying Handle

9.3.1 An extinguisher having a total mass of 1.5 kg or more and having a cylinder diameter of 75 mm or more shall have a carrying handle.

NOTE — The valve assembly head itself may be considered a handle, provided it meets the requirements of 9.3.2 and 9.3.3.

9.3.2 A handle shall be not less than 90 mm long for an extinguisher of 7.0 kg or more total mass and not less than 75 mm long for an extinguisher of less than 7.0 kg total mass.

9.3.3 There shall be not less than 25 mm clearance between extinguisher body and the carrying handle when the handle is in the carrying position.

9.4 Mounting

9.4.1 Each extinguisher intended for wall mounting shall be provided with a means of mounting.

9.4.2 A wall mounting hook shall require both a horizontal and a minimum 6 mm vertical motion to remove the extinguisher from the wall.

EXCEPTION — A minimum vertical motion of 3 mm is acceptable for an extinguisher having a gross mass of 5.4 kg or less.

9.4.3 A mounting bracket shall be capable of withstanding a static load of five times the fully charged mass of the extinguisher, when tested in accordance with 9.4.4.

9.4.4 Place an extinguisher charged to its rated capacity in the mounting bracket provided with the extinguisher after the mounting bracket has been secured to a wood board. Secure the board in a vertical position and apply a static load of four times the full extinguisher mass (or a total load of 45 kg minus the full extinguisher mass, minimum) to the top of the extinguisher. Hold the load for 5 min.

9.4.5 A mounting bracket equipped with a strap shall not permit the extinguisher to drop to the floor when the strap clamp is opened. The clamp releasing device shall be of a colour contrasting with that of the immediate extinguisher background and shall be visible. The method of release shall be obvious when viewing the front of the extinguisher.

9.4.6 A hanger loop shall be located so that the operating instructions face outward when the extinguisher is supported by the mounting means.

9.5 Caps, Valves and Closures

9.5.1 Cylinder caps, valves and closures shall be designed to provide release of pressure before complete disengagement.

9.5.2 Threaded connections on cylinder shall have at least four full threads of engagement and be required to relieve pressure with at least two full threads of engagement. Other types of valves, caps and closures are permissible if they can satisfy the same requirements, particularly with regard to recurrent tests and filling.

9.5.3 The inside diameter of a filling opening for a rechargeable type extinguisher shall be no less than 19 mm.

9.5.4 An extinguisher collar with external threads shall have sufficient height so that the cap or valve does not contact the dome or bottom with the gasket removed.

9.5.5 A cap, valves or closure shall withstand the burst test pressure specified for the cylinder for 1 min without rupture. For this test, remove or plug pressure relief devices.

9.5.6 The edges and surfaces of a fire extinguisher and its mounting bracket shall not be sufficiently sharp to constitute a risk of injury to persons during intended use or while performing maintenance.

9.6 Safety Devices

9.6.1 High pressure cylinders and cartridges shall be provided with a safety device in accordance with national regulations.

9.6.2 There are no compulsory safety systems required for low-pressure extinguishers. However, if such a system is used, it must be appropriately sized and positioned. The operating pressure of the device shall not exceed the test pressure (P_t) nor be less than the maximum service pressure (P_{ms}).

9.7 Manufacturing Tests

9.7.1 Low-Pressure Cylinders

9.7.1.1 At least one cylinder from each batch of 500 or less shall be subjected to the burst tests. If the test results are not acceptable, randomly select five additional cylinders from the same batch and repeat the tests. If one of the cylinders does not pass the test, the batch is rejected and made unserviceable. At the option of the manufacturer, the burst and crushing test may be conducted on the same cylinder.

9.7.1.2 Each cylinder shall be subjected to the test pressure (P_t) for 30 s, without leakage, failure or visible deformation.

9.7.2 Leakage Test (Type Test)

Each stored-pressure and carbon dioxide extinguisher and gas cartridge shall be subjected to a leakage test and comply with the following requirements:

- a) Stored-pressure extinguishers fitted with a gauge as specified in 7.4.1.3, the leakage rate shall not exceed a rate of loss of pressurizing content equivalent to 5 percent per annum of service pressure.
- b) Gas cartridges and stored-pressure extinguishers without gauges as specified in 7.4.1.2, the maximum loss of contents per annum shall not exceed the following:
 - 1) for extinguishers: 5 percent or 50 g, whichever is less, and
 - 2) for gas cartridges: 5 percent or 7 g, whichever is less.
- c) Carbon dioxide extinguishers the maximum loss of contents shall not exceed 5 percent per annum.

NOTE — All stored-pressure extinguisher soap solution test be conducted to check leakage as a routine test.

9.8 Requirements for Plastics Components

9.8.1 General Requirements

9.8.1.1 Plastics components of portable fire extinguishers shall comply with the following requirements.

The test and conformity checks shall be carried out on components which correspond to the mass-produced components in respect of the material used, the form and the method of manufacture.

9.8.1.2 It is recommended that the plastic used, be identifiable at all times.

Any change in the material, the form, or the method of manufacture requires a new test.

9.8.1.3 It is necessary to have access to data supplied by the manufacturer relating both to the material itself and the manufacturing procedures.

9.8.1.4 To verify the attachment of plastic parts following the air-oven ageing, ultraviolet light exposure and impact-resistance tests, attach the plastic part(s) to an extinguisher and then subject the assembly to the appropriate pressure test.

9.8.2 Requirements for Normally Pressurized Components

9.8.2.1 Burst strength

9.8.2.1.1 Conduct burst tests at three temperatures as described below:

Subject at least three components to the burst test in accordance with 9.2.2 using an appropriate liquid at temperatures of $27 \pm 5^\circ\text{C}$, the minimum recommended operation temperature marked on the extinguisher (see 7.1), and $55 \pm 5^\circ\text{C}$. Increase the pressure at a rate of 2 ± 0.2 MPa/min.

9.8.2.1.2 The bursting pressure before and after the ageing and ultraviolet light exposure test shall be at least equal to the minimum burst pressure (P_b).

9.8.2.2 Air-oven ageing

9.8.2.2.1 Subject at least three components to accelerated ageing in an oven at 100°C for 180 days. Fit the components with adapters to apply normal assembly stresses.

9.8.2.2.2 Following the exposure, condition the components for 5 h at $27 \pm 5^\circ\text{C}$ and subsequently inspect them for cracking. No cracking shall be permitted.

9.8.2.2.3 Subject the components to the burst test in accordance with 9.2.2 at $27 \pm 5^\circ\text{C}$ using a suitable liquid at a rate of pressure increase of 2 ± 0.2 MPa/min. The bursting pressure (P_b) shall be at least equal to that specified for the cylinder.

9.8.3 Ultraviolet Light Exposure

9.8.3.1 Subject at least six components to an artificial weathering test in accordance with 9.8.3.4 for 500 h and then condition them for 5 h at $20 \pm 5^\circ\text{C}$.

9.8.3.2 Following the exposure, inspect the samples for cracking. No cracking shall be permitted.

9.8.3.3 Subject the components to the burst test in accordance with 9.2.2 at $20 \pm 5^\circ\text{C}$ using a suitable liquid at a rate of pressure increase of 2 ± 0.2 MPa/min. The bursting pressure (P_b) shall be at least equal to that specified for the cylinder.

9.8.3.4 Use two stationary enclosed carbon-arc lamps to obtain the ultraviolet light. The arc of each lamp is to be formed between two vertical carbon electrodes, 12.7 mm in diameter, located at the centre of a removable vertical metal cylinder, 787 mm in diameter and 450 mm in height. Enclose each arc in a clear borosilicate-glass globe. Mount the samples vertically on the inside of the revolvable cylinder, facing the lamps, and revolve the cylinder continuously around the stationary lamps at 1 rev/min. Provide a system of nozzles so as to spray each sample, in turn, with water as the cylinder revolves. During each operating cycle (total of 20 min), expose each sample to the light and water spray for 3 min and to the light only for 17 min. Maintain the air temperature within the revolving cylinder of the apparatus during operation at $63 \pm 5^\circ\text{C}$.

Alternatively, test by using a Xenon arc source, for a period of 500 h may be carried out. Use the following conditions:

- a) $65 \pm 3^\circ\text{C}$ black panel temperature;
- b) 50 ± 5 percent relative humidity;
- c) spray cycle: 10² min dry interval, 18 min water spray; and
- d) total dose of exposure : 1 GJ/m² (500 h at 550 W/m²).

9.8.4 Impact Resistance

9.8.4.1 Mount at least four samples subjected to the ageing test (see 9.8.2.2) (two with and two without the safety-locking device engaged), and pressurize the extinguisher cylinder to the maximum service pressure (P_{ms}) with nitrogen after being filled 95 percent with a water and anti-freeze solution. Test the samples at $-27 \pm 5^\circ\text{C}$ or at the minimum recommended operation temperature, whichever is lower. The test is carried out as described in 7.5.1.

9.8.4.2 No hazardous changes shall occur to the valve assembly such as splinters, fractures or cracks. The valve

shall then be capable of withstanding the test pressure (P_t) without bursting.

9.8.5 Normally Non-pressurized Components

9.8.5.1 Subject plastic extinguisher components which withstand pressure upon extinguisher operation to the burst, air-oven ageing and impact-resistance tests. The air-oven exposure is either 100°C for 70 days or 87°C for 180 days at the manufacturer's choice.

9.8.5.2 External plastic components shall comply with the ultraviolet light test.

9.8.6 Test for Exposure to Extinguishing Medium

9.8.6.1 There shall be no damage to polymeric siphon tubes which have been conditioned in accordance with 9.8.6.3, when installed in test extinguishers and subjected to the mechanical resistance test described in 7.5.

9.8.6.2 Following conditioning in accordance with 9.8.6.3, ring samples cut from polymeric siphon tubes shall not exhibit degradation in excess of 40 percent of the original tensile or ring crushing strength value.

9.8.6.3 Place complete siphon tubes in contact with the extinguishing (water based only) media with which they are to be used. Totally cover or immerse ring samples, 12.7 mm wide, cut from unaged siphon tubes in the media. Ensure the samples do not touch each other or the container holding the media and samples. Place the container of media, with the samples in place, in a preheated oven at $90 \pm 5^\circ\text{C}$ for 210 days. After the test exposure, cool the samples in air at $27 \pm 5^\circ\text{C}$ for at least 24 h before any tests or dimensional measurements are conducted. Subject the ring samples to a crush test between two parallel flat plates using a testing machine capable of applying a compressive load at a uniform rate of 5 mm/min and recording the load *versus* the deflection. If the nature of the material is such that meaningful test results cannot be obtained, other tests, such as tensile tests, may be conducted.

9.9 Hose Assemblies (Batch Test)

9.9.1 Extinguishers with a charge greater than 3 kg shall be equipped with a hose assembly having a minimum length of 400 mm.

9.9.2 The hose and coupling system shall function throughout the operating temperature range, and coupling systems shall be designed and fitted in such a way that they cannot damage the hose.

9.9.3 The burst pressure of a hose assembly fitted with a shut-off nozzle shall be equal to or greater than appropriate

value below. The test pressure shall be established by increasing the pressure to the minimum allowable burst pressure in a time no less than 30 s, maintaining that pressure for 30 s during which failure shall not occur and then increasing the pressure until failure.

For all types except CO₂ and clean agent extinguishers:

- a) 2.0 times the maximum service pressure (P_{ms}), the test being carried out at 7 ± 5 °C; and
- b) 1.5 times the maximum service pressure (P_{ms}), the test being carried out at 55 ± 2 °C.

For CO₂ and clean agent extinguishers:

- a) 1.5 times the maximum service pressure (P_{ms}), the test being carried out at 27 ± 5 °C; and
- b) 1.25 times the maximum service pressure (P_{ms}), the test being carried out at 55 ± 5 °C.

9.9.4 A hose assembly without a shut-off nozzle shall be capable of withstanding, without leakage, a hydrostatic pressure equal to the extinguisher test pressure, (P_t) held for at least 30 s.

9.10 Method of Operation (Batch Test)

The extinguisher shall be operated by piercing, opening and/or breaking a sealing device, thus releasing its contents. Extinguishers shall operate without inversion. It shall not be necessary for any movement of the actuating mechanism to be repeated in order to initiate discharge of the extinguisher. The forces or the energy necessary to operate the extinguisher shall not exceed the values given in Table 10 for temperatures up to 55 °C.

The energy of 2 J is obtained by allowing the 4 kg mass used in the mechanical resistance (impact) test described in 7.5 to fall from a height of 50 mm. The impact shall be applied in the direction of the operating mode.

9.11 Safety-Locking Devices (Batch Test)

9.11.1 The operating mechanism shall be provided with a safety device to prevent inadvertent operation. The release of the safety device with tamper indicator shall involve an operation distinct from that of the operation mechanism and shall require a force of no less than 20 N but not exceeding 100 N. It shall be possible to determine whether the apparatus may have been operated.

9.11.2 The safety-locking device shall be made of a corrosion-resistant material.

9.11.3 The safety-locking pin or other device shall be visible from the front of the extinguisher when the extinguisher is mounted in its mounting bracket.

Table 10 Force or Energy Required to Operate the Extinguisher
(Clause 9.10)

Type of Operation	Maximum Force Required	Energy
(1)	N (2)	J (3)
With one finger	100	
With full hand	200 ¹⁾	
With impact (strike knob)		2

¹⁾ For carbon dioxide extinguishers, this maximum force may be increased to 300 N.

EXCEPTION — The safety-locking pin may be on the reverse side of the extinguisher if pictographic operating instructions on the front illustrate the intended method of operation.

9.11.4 If the safety-locking device is attached to the extinguisher by a chain or similar device, the chain shall be attached so as to not interfere with the discharge stream.

9.11.5 A tamper indicator such as a seal shall be provided to retain the safety-locking device in place and to indicate tampering with or use of the extinguisher.

9.11.6 The tamper indicator shall be constructed so that it must be broken to operate the extinguisher. The force required to break the tamper indicator shall not exceed 70 N.

EXCEPTION — If the tamper indicator is broken by the action needed to start discharge of the extinguisher, or if an internal load is continuously applied to the release mechanism, the force required to accomplish discharge or release of the internal load may exceed 70 N, but shall not exceed 140 N.

9.12 Requirements for Pressure Gauges and Indicators for Low-Pressure Extinguishers

9.12.1 General

9.12.1.1 A rechargeable extinguisher of the stored-pressure type (except carbon dioxide) employing a single chamber for both the extinguishing medium and the expellant gas shall be equipped with a pressure gauge to show the amount of pressure in the chamber regardless if the valve is opened or closed.

9.12.1.2 The operable pressure range of the gauge shall reflect the operating temperature-pressure relationship of the extinguisher (*see* 7.1).

9.12.1.3 The pressure gauge face shall indicate the appropriate units for which the gauge is calibrated, such as bar, or kPa, or any combination of pressure units.

9.12.1.4 The maximum indicated gauge pressure shall be

between 150 percent and 250 percent of the indicated service pressure (P_s) at 20 °C, but not less than 120 percent of the maximum service pressure (P_{ms}). The gauge dial shall indicate, in green, the operable pressure range of the extinguisher. The zero, service, and maximum indicated gauge pressures shall be shown in numerals and with marks. The background of the gauge face above a horizontal line through the lowest required markings shall be red. The arc of the dial from the zero pressure point to the lower end of the operable range shall read 'Recharge'. The arc of the dial from the higher end of the operable range to the maximum indicated pressure shall read 'Overcharged'. All numerals, letters, and characters in the recharge, operable, and overcharge portions of the dial shall be white. Pointers shall be yellow, and the tip of the pointer shall end in the arc of the pressure indicating dots, and shall have a maximum tip radius of 0.25 mm.

The length of the pointer from the point of rotation of the pointer to the tip, measured at the zero pressure point, shall be at least 9 mm for extinguishers having a charge greater than 2 kg or at least 6 mm for extinguishers having a charge of 2 kg or less. The length of the arc from zero pressure to the indicated service pressure shall be at least 12 mm for extinguishers having a charge greater than 2 kg or at least 9 mm for extinguishers filled with clean agents or having a charge of 2 kg or less.

9.12.1.5 The mark used to indicate the service pressure at 27°C should be no less than 0.6 mm and no more than 1.0 mm wide.

9.12.1.6 The pressure gauge face shall be marked to indicate the appropriate extinguishing medium with which it can be used.

9.12.1.7 The pressure gauge shall be marked with the gauge manufacturer's identifying mark. The pressure gauge shall also be marked according to the following, if applicable, using a line extending as wide as, and of the same stroke thickness as, the manufacturer's identifying mark.

9.12.2 Calibration Test — Gauges and Indicators

9.12.2.1 An indicator shall be accurate to within 4 percent of the service pressure (P_s) at the lower limit of the operable range.

9.12.2.2 The error of a pressure gauge at the indicated service pressure (P_s) shall not exceed ± 4 percent of service pressure.

The error at the upper and lower limits of the operable range shall not exceed the following percentages of service pressure:

- a) ± 4 percent for powder and water-based extinguisher gauges; and
- b) ± 8 percent for clean-agent extinguisher gauges.

At the zero pressure mark the error shall not exceed 12 percent, nor fall below 0 percent of the service pressure (P_s).

At the maximum indicated pressure the error shall not exceed ± 15 percent of the service pressure (P_s).

9.12.2.3 The pressure gauge or indicator is to be installed on a deadweight gauge tester or a piping apparatus with a master gauge having an accuracy of no less than 0.25 percent. The pressurizing medium may be oil, water nitrogen, or air, but all tests on a given type of gauge are to be conducted using the same medium. The pressure is to be applied to the gauge under test in uniform increments until the upper limit of the gauge is reached. The pressure then is to be reduced in the same increments until the zero point is reached. The pressure applied, the gauge or indicator reading, and net error are to be recorded for each increment in both the increasing and decreasing pressure conditions.

9.12.3 Burst Strength Test — Gauges and Indicators

9.12.3.1 A pressure gauge or an indicator shall withstand, for 1 min, a pressure of six times the indicated service pressure without rupture. In addition, if the Bourdon tube or pressure-retaining assembly bursts at a pressure less than eight times the indicated service pressure, no parts of the device shall be discarded.

9.12.3.2 Attach the sample gauge or indicator to a hydraulic pressure pump after all air has been excluded from the test system. Place the sample in a test cage and apply pressure at a rate of approximately 2.0 MPa/min until the required test pressure is reached. Hold the pressure is to be held at this point for 1 min, then increase the pressure until rupture occurs or eight times the indicated service pressure is reached, whichever occurs first.

9.12.4 Overpressure Test — Gauges

9.12.4.1 The difference in readings of indicated service pressure, before and after a pressure gauge has been subjected for 3 h to a pressure of 110 percent of the indicated gauge capacity, shall not exceed 4 percent of the indicated service pressure.

9.12.4.2 Subject sample pressure gauges to the required test pressure for 3 h. Then release the pressure and allow the gauges to stand at zero pressure for 1 h. Subject the gauges to the calibration test described in 9.12.2.

9.12.5 Water Resistance Test — Gauges and Indicators

A gauge or indicator for use on an extinguisher shall remain watertight after being immersed at a depth of 0.3 m in water for 2 h, and after being subjected to the salt-spray corrosion test (see 7.6.1).

9.12.6 Leakage Test — Gauges and Indicators

9.12.6.1 A pressure gauge or indicator shall not leak at a rate in excess of 1×10^{-6} cm³/s when the gauge or indicator (including a pin-type indicator) is exposed to a pressure equivalent to the intended service pressure of the extinguisher at 20 °C.

9.12.6.2 A leak detection apparatus and leak standard are to be used to verify compliance with the requirements specified in 9.12.6.1. The leak detection apparatus is to be capable of signaling, and the leak standard capable of generating, a leakage rate of 1×10^{-6} cm³/s.

9.12.6.3 Apply a pressure equivalent to the intended working pressure of the extinguisher at 27 °C to each of twelve sample gauges or indicators. Subject each sample gauge or indicator, other than a pin-type indicator, to a leak test by checking all pressurized components for leakage in order to verify compliance with the requirements given in 9.12.6.1. Test each pin-type indicator for leakage by checking the opening sealed by the indicator for leakage. None of the samples shall exhibit leakage at a rate in excess of 1×10^{-6} cm³/s.

9.12.7 Plastics Components — Gauges and Indicators

Plastic components of gauges and indicators shall meet the requirements given in 9.8.

NOTE — Alternatively, for gauges, manufacturer's certificate or calibration certificate from any recognized agency shall be made available.

9.13 Dip-Tubes and Filters — Water-Based Extinguishers

9.13.1 The dip-tube and filter of water-based extinguishers shall be constructed of materials resistant to the extinguishing medium (see 9.8.6).

9.13.2 The extinguishing medium from water-based extinguishers shall be discharged through a filter. The filter shall be placed upstream of the smallest section of the discharge passage. Each orifice of the filter shall have an area less than that of the smallest cross-section of the discharge passage. The total area of the combined filter orifices shall be at least equal to five times the smallest section of the discharge passage.

9.14 Special Requirements for CO₂ Extinguishers (Type Test)

The extinguisher horn shall be constructed to withstand

crushing when 25 kg is applied to its extremity for 5 min immediately after having completely discharged the extinguisher through the horn.

Subject the horn to the following test:

- a) Condition the horn at 55 °C for 18 h;
- b) Attach the horn to a fully charged extinguisher;
- c) Discharge the extinguisher with the valve fully open;
- d) Subject the horn to a static load of 25 kg using a circular contact surface of 50 mm diameter for 5 min applied at the end of the horn; and
- e) Check that the horn does not show any evidence of cracking or breakage.

10 MARKING AND COLOUR**10.1 Colour**

The recommended colour for extinguisher bodies is red conforming to shade No. 536 or 538 of IS 5. The paint shall conform to IS 2932.

10.2 Marking

NOTE — An example of the layout for marking is given in Fig. 5.

10.2.1 General

10.2.1.1 The operating, recharging, and inspection and maintenance instructions shall be in the form of an etched or embossed metal nameplate or band, or an acceptable pressure-sensitive nameplate attached to the side of the extinguisher body, or in the form of silk-screening of paint directly on the extinguisher body. The marking shall identify the extinguisher as to type of media and shall include the manufacturer's name and model number and the rating and classification of the fire extinguisher.

10.2.1.2 The marking shall include a sequential serial number.

10.2.1.3 The year of manufacture, or the last two digits of the calendar year, and the factory test pressure shall be permanently marked into the extinguisher body or non-transferable nameplate. Extinguishers manufactured in the last three months of a calendar year may be marked with the following year as the date of manufacture, and extinguishers manufactured in the first three months of a calendar year may be marked with the previous year as the date of manufacture.

10.2.1.4 The marking shall include a reference to the range of temperatures at which the extinguisher is usable, such as 'Acceptable to use at temperature from ... to ...' or the equivalent.

<p>2 KG CARBON-DIOXIDE FIRE EXTINGUISHER</p> <p>INSPECTION : INSPECT MONTHLY CHECK THAT EXTINGUISHER IS CHARGED, UNDAMAGED AND SEAL IS INTACT . MAKE SURE HORN IS UNOBSTRUCTED.</p> <p>MAINTENANCE : EXAMINE CAREFULLY EVERY 12 MONTHS TO ENSURE EXTINGUISHER IS OPERABLE. RECHARGE IF MASS LOSS EXCEEDS 0.2 kg. REPLACE ANY DAMAGED PARTS. CHECK HORN FOR OBSTRUCTIONS. HYDROSTATIC RETEST TO DOT/TC REQUIREMENTS EVERY 5 YEARS.</p> <p>USE : AFTER ANY USE RECHARGE IMMEDIATELY.</p> <p>RECHARGE : CO₂ CHARGE IS 2 kg. FULL MASS STAMPED ON VALVE BODY INCLUDES HORN ASSEMBLY.</p> <p>RECORD : RECORD MAINTENANCE AND RECHARGE DATES ON ATTACHED TAG.</p> <p>FOR INDUSTRIAL USE.</p>	<p style="text-align: center;">INSTRUCTIONS</p> <p>① HOLD UPRIGHT START BACK 3 m SQUEEZE LEVER</p> <p>② PULL RING PIN AIM AT BASE OF FIRE SWEEP SIDE TO SIDE</p>  	<div style="border: 1px solid black; width: 80px; height: 40px; margin: 0 auto; text-align: center; padding: 5px;">APPROVAL MARK</div> <p>CARBON-DIOXIDE FIRE EXTINGUISHER</p> <p>CLASSIFICATION 21-B</p> <p>SERIAL NO. XX-XXXXX</p> <p>MEETS CED 22(7272)</p> <p>2kg CARBON DIOXIDE FIRE EXTINGUISHER</p> <p>SUITABLE FOR USE AT TEMPERATURES FROM -30°C TO 55°C</p> <p>PRESSURE TESTED TO 20 MPa</p> <div style="display: flex; justify-content: space-around; margin-top: 20px;"> <div style="border: 1px solid black; padding: 5px; text-align: center;">MODEL 322</div> <div style="border: 1px solid black; padding: 5px; text-align: center;">2006</div> </div> <p style="text-align: center; margin-top: 20px;">MFG. NAME</p> <p style="text-align: center;">MFG. ADDRESS</p>
----------------------------------------------------------------------------------------------------------------------------------------------------------------------------------------------------------------------------------------------------------------------------------------------------------------------------------------------------------------------------------------------------------------------------------------------------------------------------------------------------------------------------------------------------------------------------------------------------------------------------------------------------------------------------------------------------------------------------------------------------	--------------------------------------------------------------------------------------------------------------------------------------------------------------------------------------------------------------------------------------------------------------------------------------------------------------------------------------------------------------------------------------------------------------	--------------------------------------------------------------------------------------------------------------------------------------------------------------------------------------------------------------------------------------------------------------------------------------------------------------------------------------------------------------------------------------------------------------------------------------------------------------------------------------------------------------------------------------------------------------------------------------------------------------------------------------------------------------------------------------------------------------------------------------------------------------------------------------------------

FIG. 5 EXAMPLE OF LAYOUT MARKING FOR AN EXTINGUISHER

10.2.1.5 The following applicable statement or the equivalent shall be included in the marking:

- a) For rechargeable extinguishers: 'Recharge immediately after any use'; and
- b) For disposable extinguishers: 'Discard immediately after any use'.

10.2.1.6 The gas cartridge shall be permanently marked with:

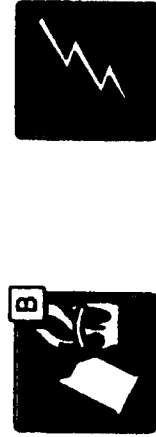
- a) Empty mass in g,
- b) Nominal full mass in g,
- c) Year of manufacture, and
- d) Name or code of the manufacturer.

The above information may be placed on the cartridge in the form of a decalcomania transfer if the cartridge is mounted on the outside of the extinguisher media chamber. If the cartridge is mounted inside the media chamber, this information shall be stenciled or stamped on the cartridge.

10.2.1.7 The marking on each extinguisher shall include its exact gross mass or minimum and maximum gross mass, which may be expressed by a tolerance. The gross mass shall include the mass of the charged extinguisher and discharge assembly.

10.2.1.8 *BIS certification marking*

The extinguisher may also be marked with the Standard Mark.

The use of the Standard Mark is governed by the provisions of the *Bureau of Indian Standards Act, 1986* and the Rules and Regulations made thereunder. The details of conditions under which a licence for the use of the Standard Mark may be granted to manufacturers or producers may be obtained from the Bureau of Indian Standards.

10.2.2 *Operating Instructions*

10.2.2.1 For the purpose of applying the requirements of this section, the 'operating instructions' are defined as those necessary to accomplish intended discharge of the extinguishing media including any warnings. An example of the layout marking is given in Fig. 6.

10.2.2.2 Clean-agent fire extinguishers shall contain the following warning or equivalent as part of the operating instructions:

WARNING — The concentrated agent when applied to the fire can produce toxic by-products. Avoid inhalation of these materials by evacuating and ventilating the area. Do not use in confined spaces of less than XXX cubic metres per extinguisher.

NOTE — XXX is the volume in cubic metres corresponding to the agent's LOAEL times the nominal charge of the extinguisher.

10.2.2.3 The operating instructions shall face outward and cover no more than a 120° arc on the extinguisher body. The marking required in 10.2.2.4 and 10.2.3 shall together occupy a minimum surface area of 75.0 cm² for an extinguisher having a diameter greater than 80.0 mm and 50.0 cm² for an extinguisher having a diameter of 80.0 mm or less.

10.2.2.4 The operating instructions shall be arranged as follows:

- a) Word 'INSTRUCTIONS' shall be at the top of the nameplate. The minimum letter height shall be 6.0 mm for an extinguisher having a diameter greater than 80.0 mm and 5.0 mm for an extinguisher having a diameter of 80.0 mm or less. As an option, the words FIRE EXTINGUISHER or EXTINGUISHER may be added to the word INSTRUCTIONS;
- b) Operating instructions shall be in the form of numerically sequenced pictographs. A single pictograph may include two instructions;
- c) Sequence of pictographs shall illustrate, with pictures, the recommended actions necessary for intended operation of the extinguisher. Words may be added. The sequence shall be as follows:
 - 1) making ready the extinguisher by disengaging the safety-locking device,
 - 2) aiming the extinguisher at the base of the fire, including the recommended distance from the fire at which to begin discharge, and indicating the intended operating attitude of the extinguisher,
 - 3) taking whatever action necessary to initiate operation of the extinguisher, and
 - 4) describing the intended method of applying the extinguishing media on the fire.

10.2.2.5 The extinguisher shall be marked with letters 'A', 'B' and 'C' indicating their suitability for respective class of fires as laid down in IS 2190 and numerical indicating size of fire such 2A and B etc.

10.2.3 *Use Code Symbols*

10.2.3.1 Use code symbols (*see* Fig. 6) shall be positioned directly below the operating instructions. A written description for each use code symbol may be included as part of the code in letters having a minimum height of 10 mm.

10.2.3.2 Use code symbols shall be placed on the extinguisher for those types of fires for which the extinguisher is classified. For those classes of fires for which the extinguishers is not intended for use because of

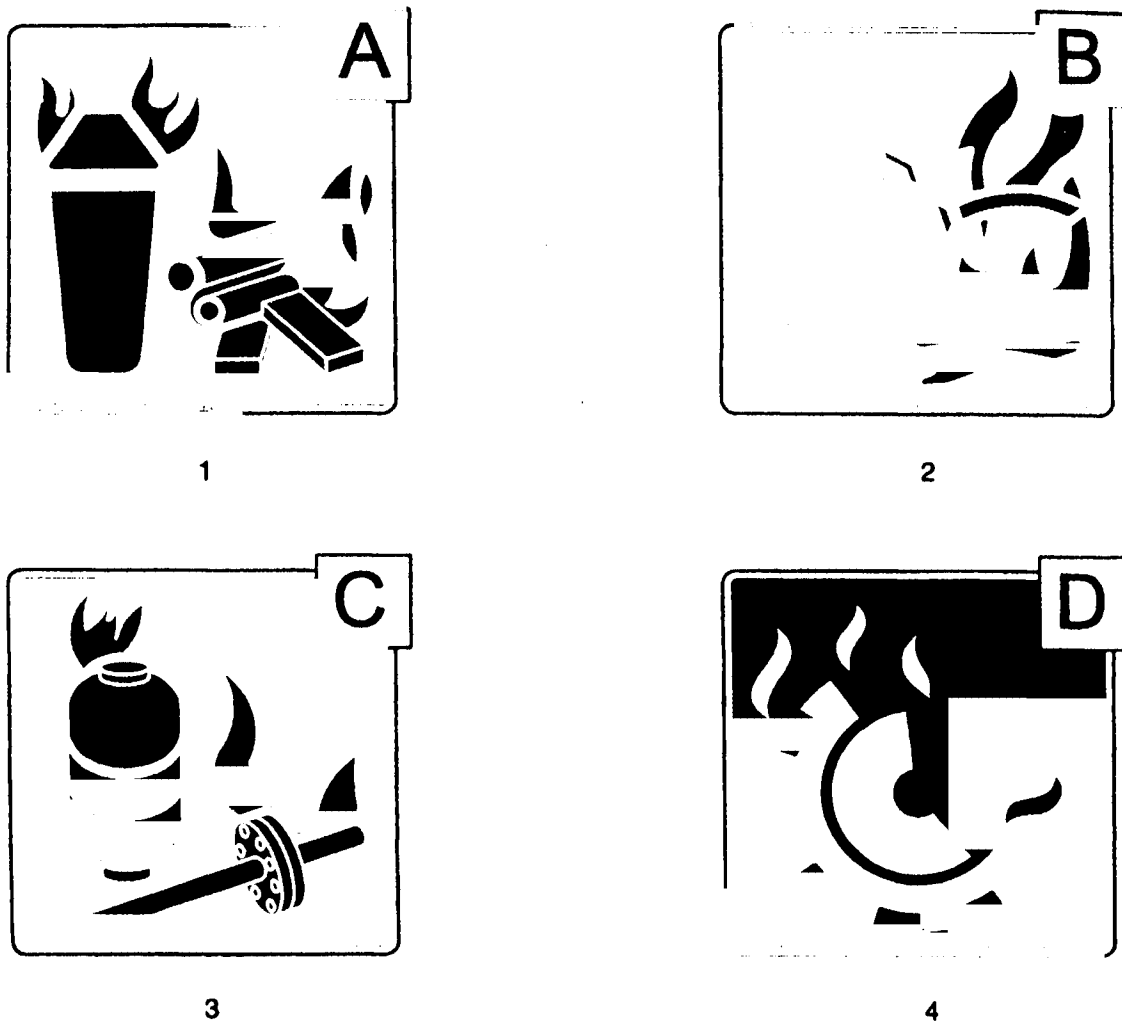

Key

1. Class A : Ordinary solid material fires
2. Class B : Flammable liquid fires
3. Class C : Gas and vapour fires
4. Class D : Combustible metal fires

FIG. 6 USE CODE SYMBOLS

potential injury to the operator, the use code symbols with a red slash shall also be placed on the extinguisher. The red slash shall be from the top left corner of the symbol to the bottom right corner.

10.2.4 Recharging Instructions

The recharging instructions on the marking of a rechargeable extinguisher shall state the intended mass and agent that shall be used in recharging, the intended expellant gas pressure or the use of a correct and a fully charged gas cartridge. Reference shall be made to use only the manufacturer's replacement parts in recharging the extinguisher. However, in lieu of detailed recharge instructions, these instructions may simply instruct the user to return the extinguisher to the dealer or manufacturer

for recharging, using the following words or the equivalent: "Return to an authorized recharger for recharging in accordance with Service Manual No...".

10.3 Inspection Instructions

The inspection instructions shall state that the extinguisher is to be checked to ensure that:

- a) The seals and tamper indicators are not broken or missing;
- b) It is full (by weighing or lifting);
- c) It is not obviously damaged, corroded, leaking or has a clogged nozzle; and
- d) Its pressure gauge reading or indicator is in the operable range or position.

11 MANUALS**11.1 User Manual and Service Manual**

A user manual shall be provided with each extinguisher. This manual shall contain the necessary instructions, warnings, and cautions for the intended installation, operation and inspection of the extinguisher. The manual shall also reference the manufacturer's service manual for maintenance and recharging of the extinguisher.

The manufacturer shall prepare a service manual for each model fire extinguisher. It shall be made available upon request and shall:

- a) Contain necessary instruction, warnings, and cautions, a description of servicing equipment, and a description of recommended operations for intended servicing,
- b) Provide a list of part numbers of all replaceable parts; and
- c) Indicate that the pressure gauge attached to the extinguisher shall not be used to determine when the intended service pressure has been reached. and a pressure regulator shall be used if the pressure service is a tank of high pressure gas.

ANNEX A
(Clause 2)

LIST OF REFERRED INDIAN STANDARDS

<i>IS No.</i>	<i>Title</i>	<i>IS No.</i>	<i>Title</i>
5 : 1994	Colours for ready mixed paints and enamels (<i>fourth revision</i>)		mechanical foam for the fire fighting
1708 (Part 1) : 1986	Method of testing of small clear specimens of timber: Part 1 Determination of moisture content (<i>second revision</i>)	6910 : 1985	Method of testing corrosion resistance of electroplated and anodized aluminium coatings by acetic acid salt spray (AAS) test (<i>first revision</i>)
2190 : 1992	Selection, installation and maintenance of first-aid fire extinguisher — Code of practice (<i>second revision</i>)	7285 : 1988	Specification for seamless steel cylinder for permanent and high pressure liquefiable gases (<i>second revision</i>)
2932 : 2003	Enamel, synthetic, exterior; a) undercoating, b) finishing — Specification (<i>third revision</i>)	7673 : 2004	Fire fighting equipment — Glossary of terms (<i>first revision</i>)
4308 : 2003	Dry chemical powder for fighting B and C class fires — Specification (<i>second revision</i>)	14609 : 1999	Dry chemical powder for fighting A, B, C Class fires — Specification
4861 : 1984	Specification for dry powder for fighting fires in burning metals (<i>first revision</i>)	15222 : 2002	Carbon dioxide as fire extinguishing media for fire protection — Specification
4947 : 1985	Specification for gas cartridges for use in fire extinguishers (<i>second revision</i>)	15493 : 2004	Gaseous fire extinguishing systems — General requirements
4989 : 1985	Specification for foam concentrate (compound) for producing	15660 : 2006	Refillable transportable seamless aluminium alloy gas cylinder — Specification

Bureau of Indian Standards

BIS is a statutory institution established under the *Bureau of Indian Standards Act, 1986* to promote harmonious development of the activities of standardization, marking and quality certification of goods and attending to connected matters in the country.

Copyright

BIS has the copyright of all its publications. No part of these publications may be reproduced in any form without the prior permission in writing of BIS. This does not preclude the free use, in the course of implementing the standard, of necessary details, such as symbols and sizes, type or grade designations. Enquiries relating to copyright be addressed to the Director (Publications), BIS.

Review of Indian Standards

Amendments are issued to standards as the need arises on the basis of comments. Standards are also reviewed periodically; a standard along with amendments is reaffirmed when such review indicates that no changes are needed; if the review indicates that changes are needed, it is taken up for revision. Users of Indian Standards should ascertain that they are in possession of the latest amendments or edition by referring to the latest issue of 'BIS Catalogue' and 'Standards : Monthly Additions'.

This Indian Standard has been developed from Doc : No. CED 22 (7272).

Amendments Issued Since Publication

Amend No.	Date of Issue	Text Affected

BUREAU OF INDIAN STANDARDS

Headquarters :

Manak Bhavan, 9 Bahadur Shah Zafar Marg, New Delhi 110 002
Telephones : 2323 01 31, 2323 33 75, 2323 94 02

Telegrams : Manaksanstha
(Common to all offices)

Regional Offices :

	Telephone
Central : Manak Bhavan, 9 Bahadur Shah Zafar Marg NEW DELHI 110 002	{ 2323 76 17 2323 38 41
Eastern : 1/14 C.I.T. Scheme VII M, V. I. P. Road, Kankurgachi KOLKATA 700 054	{ 2337 84 99, 2337 85 61 2337 86 26, 2337 91 20
Northern : SCO 335-336, Sector 34-A, CHANDIGARH 160 022	{ 260 38 43 260 92 85
Southern : C.I.T. Campus, IV Cross Road, CHENNAI 600 113	{ 2254 12 16, 2254 14 42 2254 25 19, 2254 23 15
Western : Manakalaya, E9 MIDC, Marol, Andheri (East) MUMBAI 400 093	{ 2832 92 95, 2832 78 58 2832 78 91, 2832 78 92
Branches : AHMEDABAD. BANGALORE. BHOPAL. BHUBANESHWAR. COIMBATORE. FARIDABAD. GHAZIABAD. GUWAHATI. HYDERABAD. JAIPUR. KANPUR. LUCKNOW. NAGPUR. NALAGARH. PATNA. PUNE. RAJKOT. THIRUVANANTHAPURAM. VISAKHAPATNAM.	