

इंटरनेट

मानक

Disclosure to Promote the Right To Information

Whereas the Parliament of India has set out to provide a practical regime of right to information for citizens to secure access to information under the control of public authorities, in order to promote transparency and accountability in the working of every public authority, and whereas the attached publication of the Bureau of Indian Standards is of particular interest to the public, particularly disadvantaged communities and those engaged in the pursuit of education and knowledge, the attached public safety standard is made available to promote the timely dissemination of this information in an accurate manner to the public.

“जानने का अधिकार, जीने का अधिकार”

Mazdoor Kisan Shakti Sangathan

“The Right to Information, The Right to Live”

“पुराने को छोड़ नये के तरफ”

Jawaharlal Nehru

“Step Out From the Old to the New”

IS 12440 (1988): precast concrete stone masonry blocks [CED 53: Cement Matrix Products]



“ज्ञान से एक नये भारत का निर्माण”

Satyanarayan Gangaram Pitroda

“Invent a New India Using Knowledge”



“ज्ञान एक ऐसा खजाना है जो कभी चुराया नहीं जा सकता है”

Bhartrhari—Nitiśatakam

“Knowledge is such a treasure which cannot be stolen”

BLANK PAGE



Indian Standard

**SPECIFICATION FOR
PRECAST CONCRETE STONE
MASONRY BLOCKS**

(First Reprint MARCH 1994)

UDC 691.327—431

© Copyright 1989

BUREAU OF INDIAN STANDARDS
MANAK BHAVAN, 9 BAHADUR SHAH ZAFAR MARG
NEW DELHI 110002

Indian Standard

SPECIFICATION FOR PRECAST CONCRETE STONE MASONRY BLOCKS

0. FOREWORD

0.1 This Indian Standard was adopted by the Bureau of Indian Standards on 10 August 1988, after the draft finalized by the Cement and Concrete Sectional Committee had been approved by the Civil Engineering Division Council.

0.2 Stone is a potential building material in those areas where it is available in abundance. Presently, stones of irregular shape and size are being used in the form of random rubble masonry for construction of walls, which not only consume excessive materials but are undesirably massive also. Besides, it is time consuming and calls for skilled labour. The use of stone spalls in the form of precast concrete blocks ensures consistent quality, uniform strength, increase in speed of construction, reduction in materials requirement, lower foundation loads, better aesthetic look and performance, and finally saves the floor space in a building. Considering these advantages, the Cement and Concrete Sectional Committee decided to bring out a specification covering the materials, manufacture and physical properties of precast concrete stone masonry blocks.

0.3 Precast concrete stone masonry blocks, already extensively used in building construction in areas where stone is locally available, are likely to make considerable headway throughout the country because of the many advantages, such as strength, structural stability, thin walls, better aesthetic look, light foundation load, etc. Precast concrete stone masonry block construction is also economical because of following aspects:

- a) The units are true in size and shape. This ensures rapid construction so that more wall area is constructed per man-hour than random rubble or brick masonry construction;

- b) Fewer joints result in considerable saving in mortar as compared to normal masonry construction;
- c) The true plane surfaces obtained obviate the necessity of plaster for unimportant buildings situated in low rain fall area, and
- d) Because of uniform shape and size of the units, considerably thinner walls are possible as compared to random rubble masonry walls, thus increasing the effective floor space and reducing the load on foundation.

0.3.1 It is also possible to have stone texture exposed in walls and thus giving an attractive appearance readily adaptable to any style of architecture. It lends itself to a wide variety of surface finishes for both exterior and interior walls. These units provide a strong mechanical bond, uniting the masonry units and finish in a strong permanent bond.

0.4 Precast concrete stone masonry blocks are used for both load-bearing and non-load bearing walls, for partitions and panel walls, as backing for other types of facing material, for piers, pilasters and columns, for retaining walls and garden walls.

0.5 Precast concrete stone masonry blocks are made with normal weight aggregates. One block of 300×200×150 mm size will weigh about 18 kilograms.

0.6 For the purpose of deciding whether a particular requirement of this standard is complied with, the final value, observed or calculated expressing the result of a test or analysis, shall be rounded off in accordance with IS : 2 - 1960*. The number of significant places retained in the rounded off value should be the same as that of the specified value in this standard.

*Rules for rounding of numerical values (*revised*).

1. SCOPE

1.1 This standard covers the requirements of precast concrete stone masonry blocks, used in the construction of load bearing and non-load bearing walls.

2. TERMINOLOGY

2.0 For the purpose of this standard, the following definitions shall apply.

2.1 Block Density — The density calculated by dividing the mass of a block by the overall

volume including holes or cavities.

2.2 Height — The vertical dimension of the exposed face of a block.

2.3 Length — The horizontal dimension of the exposed face of a block.

2.4 Stone Spalls — Broken stone pieces of varying sizes obtained by breaking the natural river boulders or quarry stones.

2.5 Concrete Stone Masonry Block — A pre-cast cement concrete solid block having stone spalls in it (25-30 percent of block volume) and cement concrete with dense stone aggregate and sand. It is 100 percent solid.

2.6 Stone Face Exposed Block — A concrete stone masonry block where the stone spalls are exposed at one of its face. This face, when forms the exposed wall face, the wall gets the texture of stone surface exposed.

2.7 Width — The external dimension of a block at the bedding plane, measured at right angles to the length and height of the block.

3. DIMENSIONS AND TOLERANCES

3.1 Concrete stone masonry block is a solid block and shall be referred to by its normal dimensions. The term 'nominal' means that the dimension includes the thickness of the mortar joint. Actual dimensions shall be 10 mm short of the nominal dimensions.

3.1.1 The nominal dimensions of concrete stone masonry block shall be as follows:

Length — 300 mm;

Height — 150 mm; and

Width — 100, 150 and 200 mm.

In addition, block shall be manufactured in one third, half, two-thirds and three-quarters of its full length.

The nominal dimensions of the units are so designed that taking account of the thickness of mortar joints, they will produce wall lengths and heights which will conform to the principles of modular coordination.

3.1.2 For 200, 150 and 100 mm nominal thick walls, the blocks shall be of 300×200×150 mm, 300×150×150 mm and 300×100×150 mm nominal size respectively.

3.1.3 Blocks of nominal dimensions other than those specified in 3.1.1 may also be made by mutual agreement between the purchaser and the supplier.

3.1.4 For accommodating vertical reinforcement required in earthquake resistant construc-

tion, special block of half-width and with semi-circular recess in it (see Fig. 1) shall be used. These dimensions are suitable for 200 mm thick wall. Similar blocks shall be made for walls of thickness greater than 200 mm.

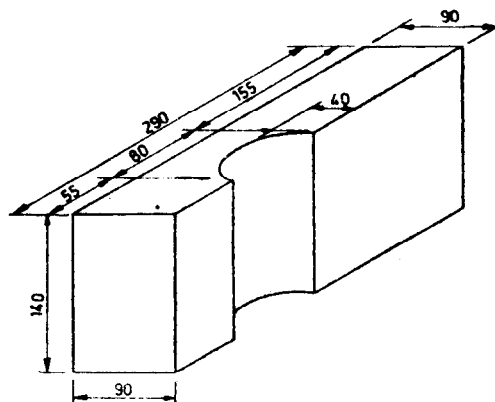

All dimensions in millimetres.

FIG. 1 SPECIAL BLOCK FOR EMBEDDING VERTICAL STEEL

3.1.5 The maximum variation in the length of the units shall not be more than ± 5 mm and maximum variation in height and width of units not more than ± 3 mm.

3.2 Subject to the provisions of 3.3 and the tolerances specified in 3.1.5, the faces of blocks shall be flat and rectangular, opposite faces shall be parallel, and all arises shall be square. The bedding surfaces shall be at right angles to the faces of the blocks.

3.3 Blocks with Special Faces — Blocks with special faces shall be manufactured and supplied as agreed upon between the supplier and the purchaser.

4. CLASSIFICATION

4.1 Concrete stone masonry blocks shall be classified according to their average compressive strength as given in Table 1.

5. MATERIALS

5.1 Cement — Cement complying with any of the following Indian Standards may be used at the discretion of the manufacturer:

IS : 269-1976 Specification for ordinary and low heat Portland cement (*third revision*)

IS : 455-1976 Specification for Portland slag cement (*third revision*)

IS : 1489-1976 Specification for Portland pozzolana cement (*second revision*)

IS : 6909-1973 Specification for supersulphated cement

IS : 8041-1978 Specification for rapid hardening Portland cement (*first revision*)

IS : 8042-1978 Specification for white Portland cement (*first revision*)

IS : 8043-1978 Specification for hydrophobic Portland cement (*first revision*).

5.1.1 When cement conforming to IS : 269-1976* is used, replacement of cement by flyash conforming to IS : 3812-1981† may be permitted up to a limit of 20 percent. However, it shall be ensured that blending of flyash with cement is as intimate as possible, to achieve maximum uniformity.

5.2 Stone Spalls — The stone spalls shall be of size ranging from 50 to 250 mm in dimension. The stone spalls shall be hard, sound, round in shape, durable, free from decay and weathering. These shall not be flaky. The spalls shall have rough surface for better bond with cement concrete. Good quality stones, such as granite, sand stone and basalt shall be used. Slate shale or any other soft and flaky stone shall not be used. The spalls shall be obtained from approved quarry or by breaking river boulder. Large size shall be broken into the required sizes and shall be stacked into two categories:

- a) 100 mm and above, and
- b) below 100 mm.

5.3 Aggregates — The aggregates used in the manufacture of blocks shall be clean and free from all deleterious matter, and shall conform to the requirements of IS : 383-1970‡.

5.3.1 Maximum size of the coarse aggregate shall be 10 mm.

5.3.2 Sand used in the manufacture of blocks shall be well graded, clean and free from deleterious matter, and shall conform to the requirements of IS : 383-1970‡. Besides, it shall have fine particles 15 to 20 percent passing 300 micron IS Sieve and 5 to 15 percent passing 150 micron IS Sieve.

5.3.3 The grading of the combined aggregates shall conform as near as possible to the requirements indicated in IS : 383-1970‡. It is recommended that the fineness modulus of the combined aggregates shall be between 3.6 and 4.

5.3.4 Flyash conforming to IS : 3812-1981† may be used for part replacement of fine aggregate up to a limit of 20 percent.

5.4 Water — The water used in the manufacture of precast concrete stone masonry blocks shall be

*Specification for ordinary and low heat Portland cement (*third revision*).

†Specification for flyash for use as pozzolana and admixture (*first revision*).

‡Specification for coarse and fine aggregates from natural sources for concrete (*second revision*).

free from matter harmful to concrete or steel embedment or matter likely to cause efflorescence in the units and shall conform to the requirements of 4.3 of IS : 456-1978*.

6. MANUFACTURE

6.1 Blocks may be manufactured either at construction site or in factory on a central casting platform using steel moulds with or without surface vibration for compaction of cement concrete.

6.2 Mould

6.2.1 Moulds shall be fabricated using mild steel plates and mild steel angles for stiffening the plates.

6.2.2 The mould be either fixed type (box with four side walls fixed at corners, and top and bottom open) or split type.

6.2.3 Split type may be either individual or gang mould.

6.2.4 Where the compaction of the concrete is done manually the mould may be either fixed type or split type. When the compaction of the blocks is done with surface vibrator, the mould shall be only split type (individual or gang mould).

6.3 Mix

6.3.1 The cement concrete mix for concrete stone masonry blocks shall not be richer than one part by volume of cement to 9 parts by volume of combined fine and coarse aggregates, and shall not be leaner than one part by volume of cement to 13 parts by volume of combined fine and coarse aggregates.

6.3.2 In case of blocks where compaction is done manually, concrete mix of medium consistency (10-12 mm slump) shall be used in order to enable proper compaction and demoulding. The consistency of the mix should be such that it may cohere when compressed in the hand without free water being visible. Too little water causes the mix to be friable whilst too much water causes difficulty in the immediate withdrawal of the mould.

6.3.3 In case of blocks where compaction is done by external vibrator, concrete mix of very low consistency (zero slump) shall be used in order to vibrate and compact the concrete under pressure.

6.4 Mixing — Concrete shall normally be mixed in a mechanical mixer.

6.4.1 Mixing shall be continued until there is a uniform distribution of the materials, and the mass is uniform in colour and consistency.

*Code of practice for plain and reinforced concrete (*third revision*).

6.4.2 When hand mixing is permitted by the engineer-in-charge, it shall be carried out on a watertight platform and care shall be taken to ensure that mixing is continued until the mass is uniform in colour and consistency.

6.5 Placing and Compaction

6.5.1 Depending upon the size of the stone spalls, these shall be used either in one layer or in two layers. When used in two layers, large size spalls of 100 mm and above shall be placed in the bottom and concrete poured all around and at top, and shall be tamped manually. Second layer of stone spalls of size 50 mm and above shall be placed over the first layer, and again concrete is poured all around and up to 20 to 30 mm above the top level of mould.

6.5.2 Depending upon the size of block and size of spalls used, the quantity of stone spall used in the block shall vary. Average volume of stone spalls used should generally be between 25 to 30 percent. However, in no block, it shall be less than 20 percent of the volume of block.

6.5.3 Each stone spall shall have a minimum space of about 15 to 20 mm around it and between mould and spall to enable the cement concrete to flow in for binding together the stone spalls and also to provide cover and give shape to the block. For blocks with exposed stone texture, the stone spalls shall touch the surface of the mould.

6.5.4 Blocks may be compacted manually as well as mechanically. In case of manual compaction, the concrete laid after the first layer of stone spalls shall be tamped with mason's tool and again it shall be tamped with suitable tampers and compacted from top and finally struck off level with trowel.

6.5.5 In case of mechanical compaction, the mould shall be filled up to overflow, vibrated and mechanically tamped using external vibrator and struck off level.

6.5.6 Demoulding shall be done 5 to 10 minutes after compaction. In case of fixed type mould it shall be pulled up with side handles while pressing down the block with the plate at top with thumb. In case of split type mould, the sides shall be removed first and the partition plates (gang mould) shall be pulled up subsequently.

6.5.7 After demoulding, the blocks shall be protected until they are sufficiently hardened to permit handling without damage.

6.6 Curing — The blocks hardened in accordance with 6.5.7 shall then be cured in a curing water tank or in a curing yard and shall be kept continuously moist for at least 14 days.

6.7 Drying — after curing, the blocks shall be dried for a period of two to four weeks depending upon weather before being used on the work. The blocks shall be allowed to complete their initial shrinkage before they are laid in a wall.

7. PHYSICAL REQUIREMENTS

7.1 General — All blocks shall be sound and free of cracks or other defects which interfere with the proper placing of the unit or impair the strength or performance of the construction. Minor chipping resulting from the customary methods of handling during delivery, shall not be deemed grounds for rejection.

7.1.1 Where blocks are to be used in exposed wall construction, the face of faces that are to be exposed shall be free of chips, cracks or other imperfections, except that if not more than 5 percent of a consignment contains slight cracks or small chipping not larger than 25 mm, this shall not be deemed grounds for rejection.

7.2 Dimensions — The overall dimensions of the blocks, when measured as given in Appendix A, shall be in accordance with 3 subject to the tolerance mentioned therein.

7.3 Compressive Strength — The minimum compressive strength at 28 days, being the average of eight blocks, and the minimum compressive strength at 28 days of individual blocks, when tested in the manner described in Appendix B, shall be as prescribed in Table 1.

TABLE 1 COMPRESSIVE STRENGTH OF CONCRETE STONE MASONRY BLOCKS
(Clauses 4.1 and 7.3)

CLASS DESIGNATION	MINIMUM AVERAGE* COMPRESSIVE STRENGTH OF BLOCKS	MINIMUM STRENGTH OF INDIVIDUAL BLOCKS
	N/mm ²	N/mm ²
5	5.0	3.5
6	6.0	4.2
7	7.0	5.0
9	9.0	6.3
10	10.0	7.5

*For 100 mm wide blocks (for 100 mm thick walls), the minimum strength may be 3.5 N/mm².

7.4 Water Absorption — The water absorption, being the average of three blocks, when determined in the manner prescribed in Appendix C, shall not be more than 6 percent by mass.

8. TESTS

8.1 Tests, as described in Appendices A to C, shall be conducted on samples of blocks selected according to the sampling procedure given in 9 to ensure conformity with the physical requirements laid down in 7.

9. SAMPLING

9.1 The blocks required for carrying out the tests laid down in this standard shall be taken by one of the methods given in 9.2. In either case, a sample of 15 blocks shall be taken from every consignment of 5 000 blocks or part thereof of same size and same batch of manufacture. From these samples, the blocks shall be taken at random for conducting the tests.

9.2 The required number of blocks shall be taken at regular intervals during the loading of the vehicle or the unloading of the vehicle depending on whether sample is to be taken before delivery or after delivery. When this is not practicable, the sample shall be taken from the stack in which case the required number of blocks shall be taken at random from across the top of the stacks, the sides accessible and from the interior of the stacks by opening trenches from the top.

9.3 The sample of blocks shall be marked for future identification of the consignment it represents. The blocks shall be kept under cover and protected from extreme conditions of temperature, relative humidity and wind until they are required for test. The tests shall be undertaken as soon as practicable after the sample has been taken.

9.4 Number of Tests

9.4.1 All the 15 blocks shall be checked for dimensions and inspected for visual defects (see 7.1 and 7.2).

9.4.2 Out of the 15 blocks, 8 blocks shall be subjected to the test for compressive strength (see 7.3) and 3 blocks to the test for water absorption (see 7.4).

10. CRITERIA FOR CONFORMITY

10.1 The lot shall be considered as conforming to the requirements of the specification if the conditions mentioned in 10.2 to 10.4 are satisfied.

10.2 The number of blocks with dimensions outside the tolerance limit and/or with visual defects, among those inspected shall be not more than two.

10.3 For compressive strength, the mean value determined shall be greater than or equal to the

minimum limit specified in 7.3.

10.4 For water absorption, the mean value determined shall be equal to or less than maximum limit specified in 7.4.

11. MANUFACTURER'S CERTIFICATE

11.1 The manufacturer shall satisfy himself that the blocks conform to the requirements of this specification and, if requested, shall supply a certificate to this effect to the purchaser or his representative.

12. INDEPENDENT TESTS

12.1 If the purchaser or his representative requires independent tests, the samples shall be taken before or immediately after delivery, at the option of the purchaser or his representative and the tests shall be carried out in accordance with this specification.

12.2 The manufacture shall supply free of charge the units required for testing.

13. MARKING

13.1 Precast concrete stone masonry blocks manufactured in accordance with this specification shall be marked permanently with the following information:

- a) Manufacturer's name or trade-mark, if any;
- b) The class of the block; and
- c) Month and year of manufacture.

13.1.1 Each block may also be marked with the Standard Mark.

NOTE — The use of the Standard Mark is governed by the provisions of the Bureau of Indian Standards Act 1986 and the Rules and Regulations made thereunder. The Standard Mark on products covered by an Indian Standard conveys the assurance that they have been produced to comply with the requirements of that standard under a well defined system of inspection, testing and quality control which is devised and supervised by BIS and operated by the producer. Standard marked products are also continuously checked by BIS for conformity to that standard as a further safeguard. Details of conditions under which a licence for the use of the Standard Mark may be granted to manufacturers or producers may be obtained from the Bureau of Indian Standards.

APPENDIX A

(Clauses 7.2 and 8.1)

MEASUREMENT OF DIMENSIONS

A-1. APPARATUS

A-1.1 Overall dimensions shall be measured with a steel scale graduated in 1 mm divisions.

A-2. SPECIMENS

A-2.1 Fifteen full size units shall be measured for length, width and height.

NOTE — These specimens shall be used for other tests also.

A-3. MEASUREMENTS AND REPORTS

A-3.1 Individual measurements of the dimensions of each unit shall be read to the nearest division of the scale and the average recorded.

A-3.2 Length shall be measured on the longitudinal centre line of each face, width across the top and bottom bearing surfaces at midlength, and height on both faces at midlength.

A-3.3 The report shall show the average length, width and height of each specimen.

APPENDIX B

(Clauses 7.3 and 8.1)

METHOD FOR THE DETERMINATION OF COMPRESSIVE STRENGTH

B-1. APPARATUS

B-1.1 Testing Machine — The testing machine shall be equipped with two steel bearing blocks (see Note), one of which is a spherically seated block that will transmit load to the upper surface of the masonry specimen, and the other a plane rigid block on which the specimen will rest. When the bearing area of the steel blocks is not sufficient to cover the bearing area of the masonry specimen, steel bearing plates meeting the requirements of **B-1.2** shall be placed between the bearing blocks and the capped specimen after the centroid of the masonry bearing surface has been aligned with the centre of thrust of the bearing blocks (see **B-4.1**).

NOTE — It is desirable that the bearing faces of blocks and plates used for compression testing of concrete masonry have a hardness of not less than 60 HRC.

B-1.2 Steel Bearing Blocks and Plates — The surfaces of the steel bearing blocks and plates shall not depart from a plane by more than 0.025 mm in any 15 mm dimension. The centre of the sphere of the spherically seated upper bearing block shall coincide with the centre of its bearing face. If a bearing plate is used, the centre of the sphere of the spherically seated bearing block shall lie on a line passing vertically through the centroid of the specimen bearing face. The spherically seated block shall be held closely in its seat, but shall be free to turn in any direction. The diameter of the face of the bearing blocks shall be at least 15 cm. When steel plates are employed between the steel bearing blocks and the masonry specimen (see **B-4.1**), the plates shall have a thickness equal to at least one-third of the distance from the edge

of the bearing block to the most distant corner of the specimen. In no case shall the plate thickness be less than 12 mm.

B-2. TEST SPECIMENS

B-2.1 Eight full size units shall be tested within 72 hours after delivery to the laboratory, during which time they shall be stored continuously in normal room air.

B-2.2 Units of unusual size, shape or strength may be sawed into segments, some or all of which shall be tested individually in the same manner as prescribed for full size units. The strength of the full size units shall be considered as that which is calculated from the average measured strength of the segments.

B-2.3 For the purpose of acceptance, age of testing the specimens shall be 28 days. The age shall be reckoned from the time of the addition of water to the dry ingredients.

B-3. CAPPING TEST SPECIMEN

B-3.0 Bearing surfaces of units shall be capped by one of the methods described in **B-3.1** and **B-3.2**.

B-3.1 Sulphur and Granular Materials — Proprietary or laboratory prepared mixtures of 40 to 60 percent sulphur (by mass), the remainder being ground fire clay or other suitable inert material passing 150-micron IS Sieve with or without a plasticizer, shall be spread evenly on a non-absorbent surface that has been lightly coated with oil (see Note). The sulphur mixture shall be heated in a thermostatically controlled heating pot to a temperature sufficient to maintain fluidity

for a reasonable period of time after contact with the capping surface. Care shall be exercised to prevent overheating and the liquid shall be stirred in the pot just before use. The capping surface shall be plane within 0.075 mm in 40 cm and shall be sufficiently rigid and so supported as not to be measurably deflected during the capping operation. Four 25 mm square steel bars shall be placed on the surface plate to form a rectangular mould approximately 12 mm greater in either inside dimension than the masonry unit. The mould shall be filled to a depth of 6 mm with molten sulphur material. The surface of the unit to be capped shall quickly be brought into contact with the liquid, and the specimen, held so that its axis is at right angles to the surface of the capping liquid, shall be inserted. The unit shall be allowed to remain undisturbed until solidification is complete. The caps shall be allowed to cool for a minimum of 2 hours before the specimens are tested. Patching of caps shall not be permitted.

Imperfect caps shall be removed and replaced with new ones.

NOTE — The use of oil on capping plates may be omitted if it is found that plate and unit can be separated without damaging the cap.

B-3.2 Gypsum Plaster Capping — A neat paste of special high strength plaster (see Note under B-4.1) and water shall be spread evenly on a non-absorbent surface that has been lightly coated with oil. Such gypsum plaster, when gauged with water and the capping consistency, shall have a compressive strength at a 2 hours age of not less than 25 N/mm², when tested as 50 mm cubes. The casting surface plate shall conform to requirements described in B-3.1. The surface of the unit to be capped shall be brought into contact with the capping paste; the specimen which is held with its axis at right angles to the

capping surface, shall be firmly pressed down with a single motion. The average thickness of the cap shall be not more than 3 mm. Patching of caps shall not be permitted. Imperfect caps shall be removed and replaced with new ones. The caps shall be aged for at least 2 hours before the specimens are tested.

B-4. PROCEDURE

B-4.1 Position of Specimens — Specimens shall be tested with the centroid of their bearing surfaces aligned vertically with the centre of thrust of the spherically seated steel bearing block of the testing machine (see Note). Masonry units shall be tested in the same direction as in service.

NOTE — For homogeneous materials, the centroid of the bearing surface shall be considered to be vertically above the centre of gravity of the masonry unit.

B-4.2 Speed of Testing — The load up to one-half of the expected maximum load may be applied at any convenient rate, after which the control of the machine shall be adjusted as required to give a uniform rate of travel of the moving head such that the remaining load is applied in not less than one nor more than two minutes

B-5. CALCULATION AND REPORT

B-5.1 The compressive strength of a concrete masonry unit shall be taken as the maximum load in Newtons divided by the gross cross-sectional area of the unit in square millimeters. The gross area of a unit is the total area of a section perpendicular to the direction of the load.

B-5.2 Report the results to the nearest 0.1 N/mm² separately for each unit and as the average for the 8 units.

A P P E N D I X C

(Clauses 7.4 and 8.1)

METHOD FOR THE DETERMINATION OF ABSORPTION

C-1. APPARATUS

C-1.1 The balance used shall be sensitive to within 0.5 percent of the mass of the smallest specimens tested.

C-1.2 Three full size units shall be used.

C-2. PROCEDURE

C-2.1 Saturation — The test specimens shall be completely immersed in water at room temperature for 24 hours. They shall be removed from the water and allowed to drain for one minute by placing them on a 10 mm or coarser wire mesh, visible surface water being removed with a damp cloth and immediately weighed.

C-2.2 Drying — Subsequent to saturation, all

specimens shall be dried in a ventilated oven at 100 to 115°C for not less than 24 hours and until two successive weighings at intervals of 2 hours show an increment of loss not greater than 0.2 percent of the last previously determined mass of the specimen.

C-3. CALCULATION AND REPORT

C-3.1 Absorption — Calculate the absorption as follows:

$$\text{Absorption, percent} = \frac{A-B}{B} \times 100$$

where

A = wet mass of unit in kg, and
 B = dry mass of unit in kg.

C-3.2 Report — Report all results separately for each unit and as the average for the three units.

Bureau of Indian Standards

BIS is a statutory institution established under the *Bureau of Indian Standards Act, 1986* to promote harmonious development of the activities of standardization, marking and quality certification of goods and attending to connected matters in the country.

Copyright

BIS has the copyright of all its publications. No part of these publications may be reproduced in any form without the prior permission in writing of BIS. This does not preclude the free use, in the course of implementing the standard, of necessary details, such as symbols and sizes, type or grade designations. Enquiries relating to copyright be addressed to the Director (Publications), BIS.

Revision of Indian Standards

Indian Standards are reviewed periodically and revised, when necessary and amendments, if any, are issued from time to time. Users of Indian Standards should ascertain that they are in possession of the latest amendments or edition.

giving the following reference:

Amendments Issued Since Publication

Amend No.	Date of Issue	Text Affected

BUREAU OF INDIAN STANDARDS

Headquarters :

Manak Bhavan, 9 Bahadur Shah Zafar Marg, New Delhi 110002
Telephones : 331 01 31, 331 13 75

Telegrams : Manaksanstha
(Common to all Offices)

Regional Offices :

	Telephone
Central : Manak Bhavan, 9 Bahadur Shah Zafar Marg, NEW DELHI 110002	{ 331 01 31 331 13 75
Eastern : 1/14 C. I. T. Scheme VII M, V. I. P. Road, Maniktola CALCUTTA 700054	37 86 62
Northern : SCO 445-446, Sector 35-C, CHANDIGARH 160036	2 18 43
Southern : C. I. T. Campus, IV Cross Road, MADRAS 600113	41 29 16
Western : Manakalaya, E9 MIDC, Marol, Andheri (East) BOMBAY 400093	6 32 92 95

Branches : AHMADABAD. BANGALORE. BHOPAL. BHUBANESHWAR.
COIMBATORE. FARIDABAD. GHAZIABAD GUWAHATI.
HYDERABAD. JAIPUR. KANPUR. PATNA. TRIVANDRUM.