

इंटरनेट

मानक



Disclosure to Promote the Right To Information

Whereas the Parliament of India has set out to provide a practical regime of right to information for citizens to secure access to information under the control of public authorities, in order to promote transparency and accountability in the working of every public authority, and whereas the attached publication of the Bureau of Indian Standards is of particular interest to the public, particularly disadvantaged communities and those engaged in the pursuit of education and knowledge, the attached public safety standard is made available to promote the timely dissemination of this information in an accurate manner to the public.

“जानने का अधिकार, जीने का अधिकार”

Mazdoor Kisan Shakti Sangathan

“The Right to Information, The Right to Live”

“पुराने को छोड़ नये के तरफ”

Jawaharlal Nehru

“Step Out From the Old to the New”

IS 9474 (1980): Principles of Mechanical Guarding of Machinery [PGD 3: Machine Tools]

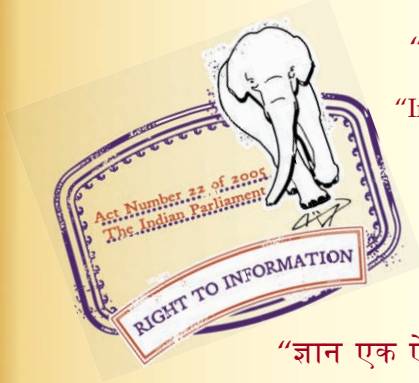

“ज्ञान से एक नये भारत का निर्माण”

Satyanarayan Gangaram Pitroda

“Invent a New India Using Knowledge”



“ज्ञान एक ऐसा खजाना है जो कभी चुराया नहीं जा सकता है”

Bhartrhari—Nitiśatakam

“Knowledge is such a treasure which cannot be stolen”



BLANK PAGE



Indian Standard
SPECIFICATION FOR
PRINCIPLES OF MECHANICAL
GUARDING OF MACHINERY

UDC 621.9 — 783.31



© Copyright 1981

INDIAN STANDARDS INSTITUTION
MANAK BHAVAN, 9 BAHADUR SHAH ZAFAR MARG
NEW DELHI 110002

Indian Standard

SPECIFICATION FOR PRINCIPLES OF MECHANICAL GUARDING OF MACHINERY

Machine Tools, Machine Tool Elements and Wood Working
Machines Sectional Committee, EDC 11

Chairman

SHRI A. K. GANGOPADHYAY
HMT Ltd, Bangalore

Members

Representing

<p>SHRI M. RANGASHAI (<i>Alternate I to</i> Shri A. K. Gangopadhyay)</p> <p>SHRI M. R. JAYARAM (<i>Alternate II to</i> Shri A. K. Gangopadhyay)</p> <p>SHRI S. C. BHUTANI (<i>Alternate III to</i> Shri A. K. Gangopadhyay)</p> <p>DR S. K. BASU</p> <p>DR R. C. BISHNU (<i>Alternate</i>)</p> <p>SHRI H. BHATTACHARJEE</p> <p>SHRI S. K. GUPTA (<i>Alternate</i>)</p> <p>DR I. V. S. R. CHARY</p> <p>DR D. R. CHAWLA</p> <p>SHRI K. L. NANGIA (<i>Alternate</i>)</p> <p>CHIEF WORKSHOP ENGINEER</p> <p>DEPUTY CHIEF MECHANICAL ENGINEER (P & P) (<i>Alternate</i>)</p> <p>SHRI V. M. HARDIKAR</p> <p>SHRI S. K. SANKPAL (<i>Alternate</i>)</p> <p>SHRI A. R. IYER</p> <p>SHRI R. C. JAIN</p> <p>SHRI A. N. KAMPANI</p> <p>SHRI V. V. KARMARKAR</p> <p>SHRI R. M. APTE (<i>Alternate</i>)</p>	<p>Central Mechanical Engineering Research Institute (CSIR), Durgapur</p> <p>Heavy Engineering Corporation Ltd, Ranchi</p> <p>Praga Tools Limited, Secunderabad Directorate General of Technical Development Establishment, New Delhi</p> <p>Railway Board (Ministry of Railways)</p> <p>Kirloskar Brothers Limited, Pune</p> <p>Kareyn Precision Machines Private Limited, Dehra Dun Director of Industries, Government of Punjab, Chandigarh Directorate General of Supplies & Disposals, New Delhi Ministry of Defence (DGOF)</p>
---	--

(*Continued on page 2*)

© Copyright 1984

INDIAN STANDARDS INSTITUTION

This publication is protected under the *Indian Copyright Act* (XIV of 1957) and reproduction in whole or in part by any means except with written permission of the publisher shall be deemed to be an infringement of copyright under the said Act.

(Continued from page 1)

Members

SHRI SHAM S. KIRLOSKAR
SHRI SUNIL KUMAR

SHRI W. C. KAWATRA
LT-COL G. L. MANWANI
SHRI K. S. MINHAS
LT-COL S. S. K. MOORTHY
MAJ S. K. SOY (Alternate)
SHRI DIPAK MUKHERJEE

SHRI D. MUKHERJEE
SHRI M. G. SHAH (Alternate)
SHRI V. NARASIMHA RAO
SHRI V. K. CHEBBI (Alternate)
SHRI V. S. PRABHAKAR RAO
SHRI GURBACHAN SINGH
SHRI C. R. SONALKAR

SHRI N. C. SUKHARAMWALA
SHRI S. G. GODBOLE (Alternate)
LT-CDR R. K. SURI
SHRI S. CHANDRASEKHARAN,
Deputy Director (Mech Engg)

Representing

Kirloskar Oil Engines Ltd, Pune
The State Trading Corporation of India, New
Delhi

Atlas Engineering Industries, Batala
Ministry of Defence (R & DE)
' XLO ' India Ltd, Bombay
Ministry of Defence (EME)

Indian Machine Tool Manufacturer's Association,
Bombay
Cooper Engineering Ltd, Pune

Central Institute of Tool Design, Hyderabad

Central Machine Tool Institute, Bangalore
Batliboi & Company Pvt Ltd, Surat
Sonalkar Tool Works Pvt Ltd, Harihar
(Karnataka)

The Mysore Kirloskar Ltd, Harihar (Karnataka)

Indian Navy
Director General, ISI (Ex-officio Member)

Secretary

SHRI GULSHAN RAI

Deputy Director (Mech Engg), ISI

Panel for Safety Code for Machine Tools, EDC 11/P10

Convener

SHRI H. K. SRIDHARA

Central Machine Tool Institute, Bangalore

Members

LT-COL G. L. MANWANI
SHRI M. RANGASHAI
SHRI N. C. SUKHARAMWALA

Ministry of Defence (R & DE), Pune
HMT Ltd, Bangalore
The Mysore Kirloskar Ltd, Harihar (Karnataka)

Indian Standard
SPECIFICATION FOR
PRINCIPLES OF MECHANICAL
GUARDING OF MACHINERY

0. FOREWORD

0.1 This Indian Standard was adopted by the Indian Standards Institution on 7 March 1980, after the draft finalized by the Machine Tools, Machine Tool Elements and Wood Working Machines Sectional Committee had been approved by the Mechanical Engineering Division Council.

0.2 A large number of machines are used in every industry. Since more and more machines are being used in industries, hazards of accidents have also increased considerably. The number of accidents due to machinery are nearly one-third of the total reportable accidents in factories each year. It, therefore, becomes necessary that dangerous parts of machinery and work in process must be guarded so that the workers who operate and maintain the machines do not get involved in accidents.

0.3 Machines, designed for safety, operated safely in a safe environment, would not only ensure the welfare of the personnel operating and maintaining them but would also go a long way in increasing productivity, reducing wastage of time and resources, and above all, increasing the production in our factories without much additional investment.

0.4 Requirements for guarding of machinery in the premises coming within the purview of the Factories Act, 1948 are contained both in the Act and in the Rules framed thereunder. These requirements are either general or specific. Where these are specific they relate to particular machines, parts of machines or to particular type of guard and are generally self-explanatory. These specific requirements, however, exist only in a limited field and for the most part the requirements are in general terms stated in Section 21 of the Act under which it is the duty of the occupier and/or manager of the factory to guard securely every dangerous part of machinery and this duty is absolute in character.

0.5 The requirements of the Act and the Rules may lead to certain practical problems. This standard is intended to give guidance to designers, manufacturers and users of machinery as to how these difficulties can best be overcome. It is impracticable to provide readymade answers to all the problems which may arise. However, since many parts or combination of parts of machinery are common to most designs this standard contains

guidance for mechanical guarding of machinery based on the experience gained over a number of years.

0.6 While mechanical guarding is intended to overcome many of the hazards that arise during use of the machinery, several other hazards like noise, vibration, illumination, dust, fumes, etc, cannot be eliminated by using mechanical guards alone. For details regarding such sources of hazard and methods of overcoming them, reference may be made to 'Indian Standard General safety requirements for machine tools and their operation' (*under preparation*).

0.7 In the preparation of this standard, assistance has been derived from the following documents:

- a) General code of practice for machine guarding prepared by the Advisory Committee on Machine Guarding of the Central Labour Institute, Bombay.
- b) BS 5304 : 1975 Safeguarding of machinery. British Standards Institution.
- c) OSHA 2057-August 1973 The principles and techniques of mechanical guarding.

1. SCOPE

1.1 This standard enunciates the principles of mechanical guarding of machinery and outlines certain broad principles that are applicable to all guarding situations. A few illustrations showing the techniques of mechanical guarding as applied to specific machines are given in Appendix D.

1.2 Even where specific devices or methods are mentioned in this standard, other devices or methods which will ensure equally good safety may be used.

1.3 Machinery which cannot be guarded in accordance with legal requirements under Factories Act, 1948, while remaining commercially practicable or mechanically useful, should not be used. It must be borne in mind that absence of injury from operating a machine is no proof that the machine is safe for operation.

1.4 The mere technical fulfilment of these requirements does not ensure proper safeguarding if examination shows lack of practicability and/or durability.

2. TERMINOLOGY

2.1 For the purpose of this standard, the following definitions shall apply.

2.1.1 Belt — Includes all power transmission belts, such as flat belts, round belts, V-belts, etc, unless otherwise specified.

2.1.2 Belt Shifter — A device for mechanically shifting belts from fast to loose pulleys or *vice versa* or for shifting belts on cone stepped pulleys.

2.1.3 Exposed to Contact — Means that the location of an object is such that a person is likely to come in contact with it and get injured.

2.1.4 Flywheels — Includes flywheels, balance wheels and flywheel pulleys mounted and rotating on crankshaft of engine or other shafting.

2.1.5 Gear — A set or train of gears comprising two or more inter-meshing gears.

2.1.6 Machinery — Any arrangement of elements having mechanical movements including complete assemblies such as prime movers, transmission drives, machines, electric generators, electric motors, rotary convertors and hydraulic accumulators.

2.1.7 Point-of-Operation — That part of a working machine at which cutting, shaping, forming or any other necessary operation is accomplished, including such other parts as may offer a hazard to the operator in inserting or manipulating stock or material.

2.1.8 Prime Mover — Includes steam, gas, oil and air engines, electric motors, steam and hydraulic turbines and other equipment used as a source of power.

2.1.9 Securely Fastened — Means that the safety device or object referred to shall be so secured in place that it cannot be moved under normal or reasonably foreseen conditions or circumstances.

2.1.10 Machinery Guard — Any barrier or device constructed to prevent a person or his clothing coming into contact with dangerous parts of machinery. The term guard is not intended to specify a particular type of safeguard, but implies a prohibition of access to dangerous part; thus for all practical purposes enclosure, fencing and guarding may be taken to have the same meaning.

2.1.11 Fixed Guard — A barrier which by the nature of its design and construction prohibits access to dangerous moving parts of machinery and remains in its position after installation.

2.1.12 Interlocking Guard — A barrier to prevent access to the dangerous parts except when those parts are at rest and prevents the machinery from being operated until the barrier is in enclosed position.

2.1.13 Automatic Guard — A device which operates to remove any part of a person exposed to danger to a position of safety and functions independently of the operator.

2.1.14 Trip Guard— A barrier or device arranged so that approach beyond a safe limit causes machinery to stop before a person can come in contact with the dangerous parts.

3. TYPES OF MECHANICAL MOTION

3.1 Certain dangers from moving parts of machinery may be anticipated and such parts or combination of parts of machinery which contribute to these dangers should be guarded. Some examples of dangerous movements of parts of machinery are given in **3.2** to **3.8**. Some of these motions with hazard potential are illustrated in Appendix A.

3.2 All movements of machinery consist basically of a few simple mechanical motions, rotary or reciprocating or a combination of the two. Both types can produce crushing and shearing actions.

3.3 A shaft is a good example of rotary motion and is found in all types of machines. It is dangerous when it is in motion unless it is covered, regardless of its speed, size or material. The danger is increased if pulleys are mounted or if there are collars, couplings, or projecting keys or set screws.

3.4 An in-running nip point exists when two or more shafts or rollers rotate parallel to one another in opposite directions. They may be in close contact or some distance apart. In-running nip points also exist at the points of contact between belts and pulleys, between chain and sprockets, between rack and pinion, between gear wheels, and between rotating parts and stationary parts of a machine.

3.5 In screw mechanism, the danger lies in the shearing action set up between the moving screw and the fixed part of the machine.

3.6 In reciprocating motion, the point of danger is where the reciprocating part approaches or crosses the fixed part like in power presses, guillotines, forge hammers, metal planers, etc.

3.7 Mechanisms which have compound motions such as those having a combination of rotary and reciprocating motions, like certain cam-gear designs, can often be more dangerous than mechanisms which have simple motions from which such compound motions were developed.

3.8 Common parts or combination of parts of machinery which contribute to danger when in motion and which need to be guarded are grouped as follows.

3.8.1 Rotating Shafts, Couplings, Spindles, Mandrels and Bars— Machine shafts, drill spindles, drills, reamers, chucks, boring bars, stock bars, vertical travel shafts on milling machines, etc.

3.8.2 In-Running Nips Between Pairs of Rotating Parts — Gear wheels, friction wheels, calender bowls, mangle rolls, metal manufacturing rolls, rubber washing rolls, breaking and mixing rolls, dough brakes, printing machines, etc.

3.8.3 In-Running Nips of the Belt and Pulley Type — Belts and pulleys (plain, flanged or grooved), chain and sprocket, gears, conveyor belts and pulleys, metal coiling drums, etc.

3.8.4 Projections on Rotating Parts — Key heads, set screws, cotter pins, coupling belts, etc.

3.8.5 Discontinuous Rotating Parts — Open-arm pulleys, fan blades, spoked gear wheels, spoked fly wheels, etc.

3.8.6 Rotating Beaters, Spiked Cylinders and Rotating Drums — Scutchers, ragflock teasers, cotton openers, laundry washers, carding engines, etc.

3.8.7 Rotating Mixer Arms in Casings — Dough mixer, rubber solution mixer, etc.

3.8.8 Rotating Worms and Spirals in Casings — Meat mincers, rubber extruders, spiral conveyors, etc.

3.8.9 Rotating High Speed Cages in Casings — Hydro-extractors, centrifuges, etc.

3.8.10 Abrasive and Cutting Wheels — Manufactured wheels, natural sand stones, etc.

3.8.11 Rotating Cutting Tools — Circular saws, milling cutters, circular shears, wood slicers, chaff cutters, woodworking machines (spindle moulders, planing machines, tenoning machines), etc.

3.8.12 Reciprocating Tools and Dies — Power presses, drop stamps, relief stamps, hydraulic and pneumatic presses, bending presses, hand presses, revolution presses, etc.

3.8.13 Reciprocating Knives and Saws — Guillotines (for metal, rubber and paper cutting), trimmers, perforators, etc.

3.8.14 Closing Nips Between Platen Motions — Letterpress platen printing machines, paper and cardboard platen machine cutters, foundry moulding machines, etc.

3.8.15 Projecting Belt Fasteners and Fast Running Belts — Belt and nut fasteners, wire pin fasteners and the like, wood working machinery belts, centrifuge belts, textile machinery side belting, etc.

3.8.16 Nips Between Connecting Rods or Links and Rotating Wheels, Cranks or Discs — Side motions of certain flat-bed printing machines, jacquard motions on looms, etc.

3.8.17 *Pawl and Notched Wheel Devices for Intermittent Feed Motions* — Planer tool feed motions, power press dial feed tables, etc.

3.8.18 *Nips Between Reciprocating and Fixed Parts, Other Than Tools and Dies* — Metal planer (reversing stops, sliding tables and fixtures) shaping machine table and fixtures, tools steady guide and steady arm on turret lathe, etc.

3.8.19 *Nips Between Rotating Control Handles and Fixed Parts* — Traverse gear handles of lathes, milling machines, etc.

3.8.20 *Moving Balance Weights and Dead Weights* — Hydraulic accumulator, counterbalance weights on large slotting machines, etc.

3.8.21 *Nips Between Rotating Wheels or Cylinders and Pans or Tables* — Sand mixers, edge runners, crushing mills, mortar mills, etc.

3.8.22 *Cutting Edges of Endless Band Cutting Machines* — Wood-working, log, metal and stone cutting band saws, cloth cutting band knives, etc.

3.8.23 *Nips Between Gears and Rack Strips* — Ink roller driver on lithographic presses, some planing machine drives, etc.

3.8.24 *Rotating Drums and Cylinder-Uncased* — Tumblers in the foundry, varnish mixers, rag digestors, etc.

3.8.25 *Nips Between Fixed and Uni-directional Moving Parts* — Buckets or hoppers on conveyors against tipping bars, steps or parts of the framework, etc.

4. PRINCIPLES OF MECHANICAL GUARDING

4.1 Experience has shown that if the various types of mechanical motion are clearly understood, the dangerous parts of any machinery can be identified and such parts or combination of parts of machinery which contribute to dangers should be guarded.

4.2 The guard shall effectively eliminate dangers from parts of machinery in motion and work in process. Effective guarding is an essential factor in efficiency and productivity. The correct elimination of dangerous conditions enables machinery operators to work with speed and efficiency.

4.3 No allowance should be made on the assumption of carefulness by workers in avoiding accidents from machinery in motion.

4.4 Intrinsic safety should be a basic feature of machinery design and installation. Where the design features do not safeguard dangerous parts, provision should be made to facilitate appropriate guarding.

5. TYPES OF GUARDS

5.1 Fixed Guards

5.1.1 This type of guard should be provided in every practicable case as the preferred method of attaining secure fencing.

5.1.2 The guard should by nature of its design and construction, prohibit access to the dangerous parts of machinery and should remain in position after installation.

5.1.3 Fixed guards may be adjustable to accommodate different sets of tools or various kinds of work. Once adjusted they should remain fixed and there should be neither movement nor detachment of them. The means of adjustment incorporated in the design should be remote from the danger zone and in no way reduce the effectiveness of the guard. Adjustment should only be made when the machine is at rest.

5.1.4 Where for the purpose of production, for example to remove some obstruction or for maintenance a fixed guard or a portion of the fixed guard is removable without the use of special tools, it should incorporate a lock to ensure that it cannot be removed while the machine is in motion. Adjustment should only be made while machine is at rest.

5.1.5 Opening for the work to be fed through the guard into the machine should be sufficient only for the size of the work-piece; it should not allow a person to gain access to the dangerous parts. The effectiveness of any fixed guard should always be judged by a test to see that finger tips cannot reach beyond a safe limit.

Figure 1 provides a guide to the relationship between the gap A in a guard and its distance B from the danger point. For example, if it is necessary to provide an opening 50 mm deep, then guard should be set not less than 400 mm from the danger point.

5.1.6 In the case of rolls instead of considering the point of contact of the rolls as the nip point, a 10 mm wide nip zone should be considered as the nip point. Illustrations in figures given under **B-1**, **B-2**, **B-3**, **B-4**, **B-5**, and **B-6** of Appendix B indicate the procedure to be used to design a properly placed guard for in-running rolls.

5.1.7 The movement of work should, wherever practicable, be controlled by rollers, slide feeds, chutes, or similar devices guaranteeing remoteness of the operator from the danger point and where possible mechanical feeding and ejection devices should be provided.

5.2 Interlocking Guards

5.2.1 Interlocking guard should be used on a machine as the first alternative, if a fixed guard cannot be used.

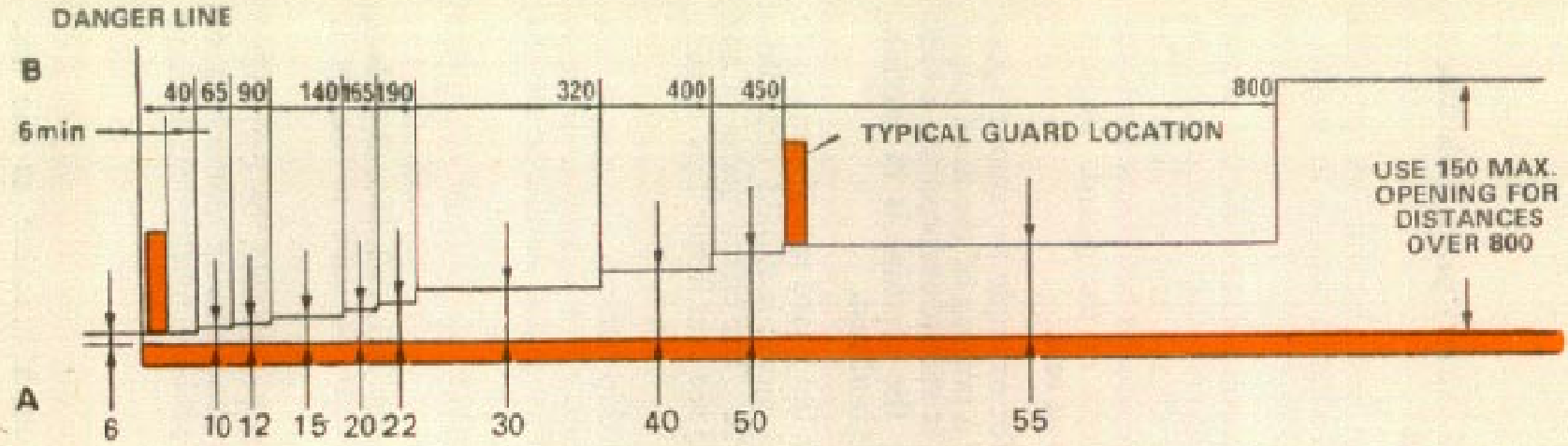

DISTANCE OF THE GUARD FROM DANGER LINE, B, mm		PERMISSIBLE WIDTH OF SLOTTED OPENING IN THE GUARD, A, mm
Above	Up to	
0	40	6
40	65	10
65	90	12
90	140	15
140	165	20
165	190	22
190	320	30
320	400	40
400	450	50
450	800	55
800	—	*150 Max

*For openings in excess of 150 mm, principles of guarding which take into consideration reach over the barriers should be followed (see 6.3).

All dimensions in millimetres.

FIG. 1 OPENINGS IN FIXED GUARDS

5.2.2 The interlocking system may be either mechanical or electrical or a combination of both. All parts of the interlocking system should as far as possible be incorporated in the design of the machine for which this type of guarding is to be used. If practicable, these guards should be designed for sequential operations. They must guard the dangerous part before the machinery can be operated, maintain the guarding until the dangerous part comes to rest and shall be failsafe.

5.2.3 Hydraulic or pneumatic systems used to operate certain types of machines, including presses, may be employed for interlocking guards. In such cases, however, the guards have to be carefully designed to ensure safety.

5.2.4 Where limit switches or microswitches are used for interlocking purposes, the switches should be positively opened and closed by the guard member.

5.2.5 Sometimes sudden braking of the rotating parts which have considerable inertia may not be practicable. In such cases a time delay device may be included in the interlocking arrangements so that the guard should open only when the rotating part has come to rest.

5.3 Automatic Guards

5.3.1 This type of guard should only be used where neither fixed nor interlocking guards are practicable to safeguard a particular danger area. Automatic guards should operate to remove any part of a person exposed to danger to a position of safety.

5.3.2 Automatic guards should function independently of the operator and its action should repeat as long as the machine is in motion.

5.3.3 The mechanism of automatic guards should be carefully adjusted in relation to the movement and physical characteristics of the dangerous parts, and frequently examined to ensure that the safeguard is properly maintained and used.

5.4 Trip Guards

5.4.1 Trip guards should be so arranged that an approach by a person beyond a safe limit causes the guard to move and the machinery to stop and/or reverse its motion before any part of the person can reach the dangerous part.

5.4.2 They are recommended to be used on machines which are normally in continuous motion where the hands (or other parts of a person) have temporarily to enter a space swept by the dangerous part or where entangling in an article or material which is being fed to a machine may occur. They can also be used where a person may be injured by being pulled

against or through the feed opening of a fixed guard. In such circumstances the person comes in contact with the guard or part of the guard capable of movement under pressure and causes the tripping device to operate.

5.4.3 The effective performance of a trip guard is greatly dependent upon the stopping characteristics of the machine which shall be controlled within defined limits. An efficient brake is normally a necessity. Trip guards, while normally of a mechanical nature, also include electrosensitive devices such as those employing the photoelectric principles.

5.4.4 The specifications for a suitable photoelectric device should be the following:

- a) At all times while any part of a person is within the danger zone, the device should ensure that such parts of the machine whose movement is a source of danger cannot come into motion.
- b) If, while a part is in motion, a person should approach the danger zone, the part should be brought to rest in such time as to ensure that trapping of the hand or any other part of such a person will not occur.
- c) The device, when completely assembled and in correct working condition shall not be so affected by stray light (direct or reflected) whether artificial, natural, or deliberately applied, as to cause danger.

5.4.5 The design of trip guards of mechanical type should be such that the machinery cannot again be set in motion unless and until the guard has been reset.

5.5 Two-Hand Control Device and Two-Hand Control System

5.5.1 This device is not a guard but safety of the operator is achieved by keeping both the hands of the operator engaged away from the danger area. If more than one person are to work on a machine this device should be provided for each operator.

5.5.2 Two push buttons or two levers be so interlocked mechanically, electrically or both that it is necessary to operate both the push buttons or levers simultaneously to start the operation of machine, and in the case of more than one device provided on a machine it should be necessary to operate all the push buttons/levers simultaneously to start the operation of the machine.

5.5.3 Two-hand control should be located in such a position that after leaving the control button/lever, the hand of the operator cannot reach the point of operation before the closing movement of the parts has stopped. This safety distance between the control button/lever from the point-of-operation is determined on the assumption that the speed of the hands

moving from button/lever to the point-of-operation is 1.6 m/s. The safety distance for various 'stop times' is given in the following table:

Time, ms	Safety Distance, mm									
	0	10	20	30	40	50	60	70	80	90
0	0	16	32	48	64	80	96	112	128	144
100	160	176	192	208	224	240	256	272	288	304
200	320	336	352	368	384	400	416	432	448	464
300	480	496	512	528	544	560	576	592	608	624
400	640	656	672	688	704	720	736	752	768	784
500	800	816	832	848	864	880	896	912	928	944
600	960	976	992	1 008	1 024	1 040	1 056	1 072	1 088	1 104
700	1 120	1 136	1 152	1 168	1 184	1 200	1 216	1 232	1 248	1 264
800	1 280	1 296	1 312	1 328	1 344	1 360	1 376	1 392	1 408	1 424
900	1 440	1 456	1 472	1 488	1 504	1 520	1 536	1 552	1 568	1 584

NOTE — 'Stop time' is the total time required to bring the moving parts at the point-of-operation to a stop.

6. ANTHROPOMETRIC DATA FOR DESIGN OF MECHANICAL GUARDS

6.1 Data based on human body measurements have an important influence upon the proper design of machine guards. Reach is limited by the length of the arm, and in the case of opening, by size of the fingers and hand as well. The distance a man can reach determines the minimum height of certain kinds of guards, or the minimum distance of barriers from the machines they are intended to fence.

6.2 A dangerous part that is within an upward reach of 2.60 m should be fenced and any part beyond this be regarded as positionally safe in the absence of facts to the contrary.

6.3 When a machine or part of machinery is fenced with a barrier and regarded as safe by position, the barrier shall be of such construction that no person can reach the dangerous parts from over or through the barrier and no unauthorized person can enter the enclosure formed by the barrier.

As far as practicable clear distance of the barrier from the machinery it is guarding shall not be more than 225 mm.

6.4 Reach around barriers can be interrupted by providing additional barrier and positionally safe area can be increased. The nearer the edge of the barrier to the reach curve, the less can the arm be bent around it as indicated in Fig. 2.

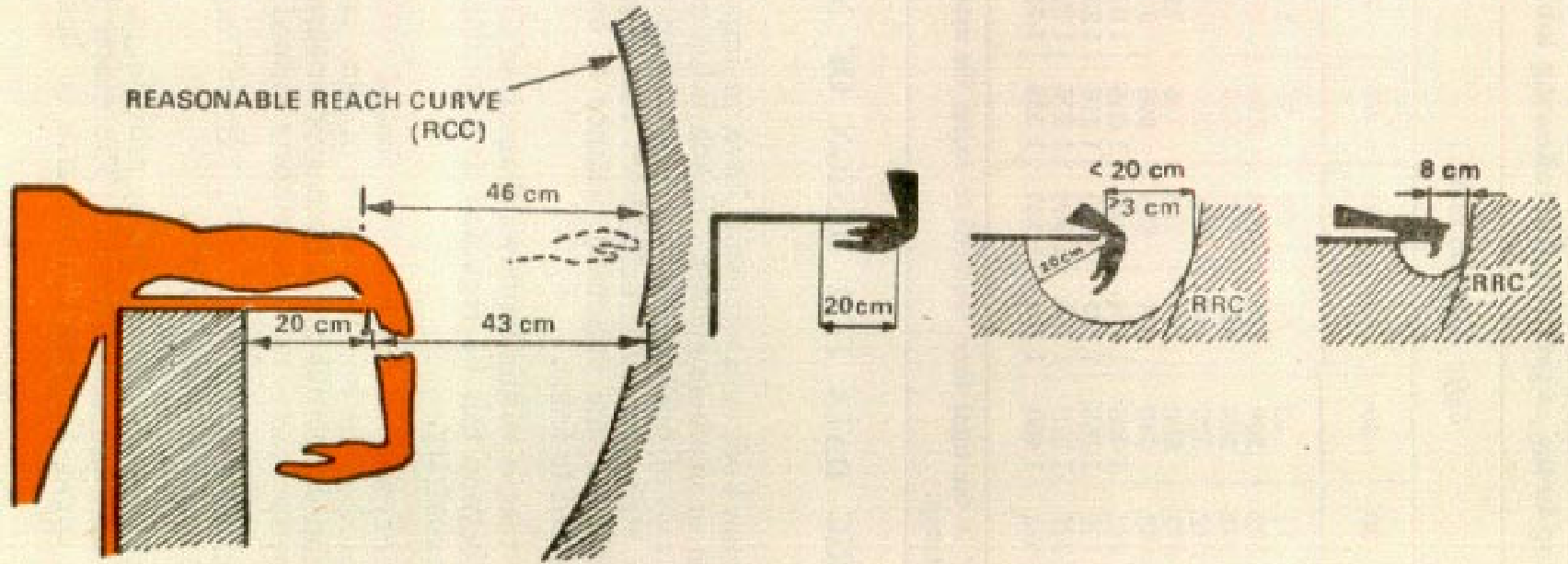

FIG. 2 EFFECT OF ADDITIONAL BARRIER AND EXTENT OF REACH OF HAND AND FINGERS AROUND ADDITIONAL BARRIER

6.5 For openings admitting fingers or hand, it can be assumed that there is no reach possible through an opening less than 1×1 cm as the fingers cannot be admitted.

6.6 If an opening admits one, two or three fingers, the distance between the guard having such an opening and the dangerous part should not be less than the maximum length of the longest finger plus a clearance allowance, as the reach is restricted by the roots of the fingers.

6.7 If the opening admits all four fingers and reach is restricted by the root of the thumb, the size and shape of the opening will be an important factor in determining the distance of the guard from the dangerous parts.

6.8 If the opening admits four fingers and thumb of the same hand, distance of the guard from the dangerous part should be determined by the maximum reasonable length of fingers and hand, or of fingers, hand and arm, at different points as shown in Fig. 1.

6.9 If the opening is sufficient to admit the whole arm and a portion of the shoulder but excludes the head and trunk, the reasonable safe reach is based on the distance from the finger tips to armpit which is not more than 84 cm.

NOTE — The above requirements are according to ILO recommendations.

7. GENERAL REQUIREMENTS OF MECHANICAL GUARDS

7.1 Guards should be so designed, constructed and used that they will:

- a) provide positive protection;
- b) prevent access to the danger zone during operations;
- c) cause the operator no discomfort or inconvenience;
- d) operate automatically or with minimum effort;
- e) not interfere with efficient operation of the machine;
- f) be suitable for the job and the machine;
- g) not weaken the structure of the machine;
- h) preferably constitute a built-in feature;
- j) provide for machine oiling, inspection, adjustment and repairs;
- k) be constructed strongly enough to resist normal wear and shock;
- m) be durable, resistant to fire and corrosion and easily repaired;
- n) withstand long use with minimum maintenance;
- p) not constitute a hazard by themselves such as splinters, pinch points, shear points, sharp corners, rough edges or other sources of accidents; and
- q) protect against operational contingencies, not merely against normally expected hazards.

7.2 The preferable material for guards under most circumstances should be metal. Framework of guards should be generally made from structural sections, pipes, strapping, bar or rod. Panelling material should be generally solid sheet metal, expanded or perforated metal or wire mesh. The use of plastic or safety glass, where visibility is required, is recommended.

7.3 Guards made of wood may be used but they have limited application due to their lack of durability and strength and relatively high maintenance cost and flammability.

7.4 All guards should be securely fastened to the machine or to the floor, wall or ceiling or any other rigid fixed structure and should be kept in place whenever the machinery is operating. Exception may be made in the case of transparent chip guards or splash guards which may be adjustable or provided with magnetic base as they may need to be shifted during the course of work.

7.5 Framework

7.5.1 The minimum dimensions of materials for the framework of the guards made from structural steel should be in accordance with the following table:

Type of Guard	Material			Other Conditions
	Rod	Angle Iron	Pipe	
Small Guards: height 75 cm or less with surface area not exceeding 1 sq. m	1 cm diameter	20 × 20 × 3 mm	—	Other construction of equal strength may be used
Braced Guards: height more than 75 cm with surface area exceeding 1 sq. m	—	25 × 25 × 3 mm	20 mm inside diameter	a) Other construction of equal strength may be used b) The guard should be rigidly braced every 90 cm or fractional part of their height to some fixed part of machinery or building structure
Unbraced Guards: (i.e., when the guard is fastened to the floor or working platform without any support or bracing)	—	38 × 38 × 3 mm	38 mm inside diameter	Other metal construction of equal strength

7.5.2 Rectangular guards should have at least four upright frame members, each of which should be securely fastened to the floor.

7.5.3 Cylindrical guards should have at least three supporting members carried to the floor.

7.6 Joints — All framework joints should be made at least equivalent in strength to the material of the frame.

7.7 Panelling

7.7.1 Panelling should be made of solid or perforated sheet metal not less than 1 mm in thickness, expanded metal not less than 1.25 mm in thickness or woven wire not less than 1.5 mm in diameter or other material of equal strength.

7.7.2 Woven wire should be of the type in which the wires are securely fastened at every cross point by welding, soldering, crimping or galvanizing, except in the case of diamond or square wire mesh made of wire 2 mm in diameter and 20 mm mesh or heavier.

7.7.3 Where visibility is required, plastic or safety glass minimum of 6 mm thickness may be used.

7.8 Fastening — Panelling material should be securely fastened to the frame by one of the following methods:

- a) With rivets or bolts spaced not more than 125 mm centre to centre. In case of expanded metal or wire mesh, metal strips or clips should be used to form a washer for rivets or bolts.
- b) By welding to frame every alternate 100 mm.
- c) By weaving through channel or angle iron or if wire mesh of wire 2 mm in diameter, 20 mm mesh or heavier issued by bending entirely around rod frames.
- d) Panelling material for pipe frames should be made into panels with rolled edges or bound with sheet metal and the panels fastened to the frame with steel clips.

NOTE — Illustrations of guard construction are given in Appendix C.

7.9 Height of Guards — Except as provided for specific installations, the minimum height of guards should be 2.60 m from the floor or platform level.

7.10 Floor Clearance — If practicable without permitting exposure to moving parts, guards should clear the floor by about 15 cm to prevent interference with cleaning around machines.

7.11 Wood Guards

7.11.1 Wood used for guards should be sound, tough, and free from any loose knots and shall conform to IS : 5966-1970*.

7.11.2 Wood guards should be made of planed lumber not less than 25 mm rough board measure or of plywood or fabricated products of equal strength and the edges and corners should be rounded off.

7.11.3 Wood guards should be securely fastened together with wood screws, hard wood dowel pins, bolts, rivets, or crimped nails, and should be equal in rigidity to metal guards fulfilling the requirement given in 7.5 to 7.7 above.

7.12 Standard Railing and Toe-Board

7.12.1 The standard railing should be 105 cm in height, with mid-rail between top rail and floor.

7.12.2 Posts should not be more than 240 cm apart. They should be permanent and substantial and smooth, and free from protruding nails, bolts and splinters. If made of pipe, the post should be 30 mm inside diameter or larger. If made of metal section or bars, their section should be equal in strength to that of $38 \times 38 \times 5$ mm angle iron. If made of wood, the posts should be 50×100 mm or larger. The upper rail should be 50×100 mm or two 25×100 mm strips one at the top and one at the side of the post. The mid-rail may be 25×100 mm or more. The rails should be on that side of the post which gives best protection and support. Distance of railing from dangerous parts should be fixed according to the requirements in 6.3 above.

7.12.3 Toe-boards should be 10 cm or more in height.

8. HORIZONTAL OVERHEAD BELT GUARDS

8.1 The guard support and framework of guard, if of angle iron, for horizontal overhead belts, ropes or chains more than 2.60 m above the floor or platform should be as given in the table below:

<i>Width of Belt</i>	<i>Framework</i>	<i>Guard Support</i>
Up to 25 cm	25×25×5 mm	38×6 mm
Over 25 and up to 35 cm	38×38×6 mm	50×8 mm
Over 35 and up to 60 cm	50×50×8 mm	50×10 mm
Over 60 cm	80×80×10 mm	65×10 mm

NOTE — For belts less than 25 cm in width, dimensions of material given under 7 above should be used.

*Specification for nonconiferous timber in converted form for general purpose.

8.2 All guards should be provided with an adequate number of supports and attachments so as to ensure sufficient rigidity and strength.

8.3 The panelling material for these guards should be solid sheet metal of 1 mm thickness or expanded metal of equal strength.

9. GUARDING OF TRANSMISSION MACHINERY

9.1 Each continuous line of shafting should be secured in position against excessive endwise movement.

9.2 Inclined and vertical shafts, particularly inclined idler shafts should be securely held in position against endwise thrust.

9.3 Horizontal Shafting

9.3.1 All exposed parts of horizontal shafting less than 2.60 m from floor or working platform, excepting runway used exclusively for oiling, or running adjustments, should be protected by a stationary casing enclosing shafting completely or by a trough enclosing sides and top or sides and bottom of shafting as the location requires.

9.3.2 Whenever shafting extends over a passage, it should be protected as required under **9.3.1** unless it is located at a height of 4.50 m or more.

9.3.3 Shafting under bench machines should be enclosed by a stationary casing, or by a trough at sides and top or sides and bottom as location requires. The sides of the trough should come within at least 150 mm of the underside of the table or if shafting is located near floor within 150 mm of floor. In every case the sides of trough should extend at least 50 mm beyond the shafting or protuberance.

9.4 Vertical and Inclined Shafting — Vertical and inclined shafting 2.60 m or less from floor or working platform, excepting maintenance runways, should be enclosed with a stationary casing in accordance with requirement of 7.

9.5 Projecting Shaft Ends

9.5.1 Projecting shaft ends should be smooth and rounded and should not project more than one-half the diameter of the shaft unless guarded by non-rotating caps or safety sleeves.

9.5.2 Unused keyways should be filled up or covered.

9.6 Pulleys

9.6.1 Pulleys, any part of which is 2.60 m or less from the floor or working platform should be guarded in accordance with the requirements of 7.

9.6.2 Pulleys serving as balance wheel on which the point of contact between belt and pulley is more than 2.60 m from the floor or platform may be guarded with a disc covering the spokes.

9.7 Location of Pulleys

9.7.1 Unless the distance to the nearest fixed pulley, clutch or handle exceeds the width of the belt used, a guide should be provided to prevent the belt from leaving the pulley on the side where insufficient clearance exists.

9.7.2 Where there are overhanging pulleys on line, or counter-shafts with no bearing between the pulley and the outer end of the shaft, a guide to prevent the belt from running off the pulley should be provided.

9.8 Belt Guides — Belt guides should not be installed except as provided in 9.7.1 and 9.7.2.

9.9 Pulleys Out of Service — Pulleys permanently out of service should not be allowed to remain on shafting which is in use.

9.10 Belt, Rope and Chain Drives

9.10.1 Where both runs of horizontal belts are 2.60 m or less from the floor level, the guard should extend to at least 38 cm above the belt or to a standard height except that where both runs of a horizontal belt are 105 cm or less from the floor, the belt should be fully enclosed in accordance with 7.

NOTE — In power plants or power generating rooms, a guard rail specified in 7.12 may be used in lieu of the above.

9.10.2 Overhead horizontal belts, with lower part 2.60 m or less from the floor or platform should be guarded on sides and bottom in accordance with 7.

9.10.3 Horizontal overhead belts more than 2.60 m above floor or platform should be guarded for their entire length under the following conditions:

- a) If located over passageways or work places and travelling at 9 m/s or more,
- b) If the centre to centre distance between pulleys is 3 m or more, and
- c) If belt is 20 cm or more in width.

9.10.4 Where the upper and lower runs of horizontal belts are so located that passage of persons between them would be possible, the passage should be either:

- a) Completely barred by a guard rail or other barrier in accordance with 7, or

- b) Where passage is regarded as necessary there should be a platform over the lower run guarded on either side by a railing completely filled in with wire mesh or other panelling material or by a solid barrier. The upper run should be so guarded as to prevent contact there with either by the worker or by objects carried by him.

9.10.5 Overhead chain and link belt drives are governed by the same rules as overhead horizontal belts and should be guarded in the same manner as belts.

9.10.6 Continuous system rope drives so located that the conditions of the ropes, particularly the splice, cannot be constantly or conveniently observed should be equipped with a warning device that will give warning when rope begins to fray.

9.11 Cone-Pulley Belts

9.11.1 The cone belts and pulley should be equipped with a belt shifter so constructed as to adequately guard the nip-point of the belt and pulley. If the frame of the belt shifter does not adequately guard the nip-point of the belt and pulley, the nip-point should be further protected by means of a vertical guard placed in front of the pulley and extending at least to the top of the largest step of the cone.

9.11.2 If the belt is of the endless type or laced with raw hide laces and a belt shifter is not desired, the belt should be considered guarded if the nip-point of the belt and pulley is protected by nip-point guard located in front of the cone extending at least to the top of the largest step of the cone and formed to show the contour of the cone in order to give the nip-point of the belt and pulley the maximum protection.

9.11.3 If the cone is located less than 1 m from the floor or working platform, the cone pulley and belt should be guarded to a height of 1 m regardless of whether the belt is endless or laced with raw hide laces.

9.12 Belt Tighteners

9.12.1 Suspended counterbalanced tighteners and all parts thereof should be of substantial construction and securely fastened; the bearings should be securely capped. Means shall be provided to prevent tightener from falling, in case the belt breaks. This can be accomplished by securely fastening cables or chains of sufficient strength to the tightener and to the roof, or some substantial object above, to prevent it from falling far enough to strike a person.

9.12.2 Where suspended counterweights are used and not guarded by location, they should be so encased as to prevent accident.

9.13 Gears — Gears should be guarded in accordance with one of the following specifications:

- a) By a complete enclosure;
- b) By a guard;
- c) By a band guard covering the face of gear and having flanges extended inward beyond the root of the teeth on the exposed side or sides. Where any portion of the train of gears guarded by a band guard is less than 2.60 m from the floor, a disc-guard or a complete enclosure to the height of 2.60 m should be provided.

NOTE — This rule does not apply to hand-operated gears used only to adjust machine parts and which do not continue to move after the hand power is removed. However, it is always a good practice to look into the matter carefully and whenever there is the slight chance of injury, it is better to provide guards.

9.14 Sprockets and Chains — All sprocket wheels and chains should be enclosed unless more than 2.60 m above the floor or platform. Where the drive extends over other machines or working areas, protection against falling should be provided.

NOTE — This does not apply to manually operated sprockets.

9.15 Opening for Oiling — When frequent oiling must be done, opening with hinged or sliding self-closing covers should be provided. All points not readily accessible should have oil feed tubes if lubricant is to be added while machinery is in motion.

9.16 Friction Drives

9.16.1 Driving point of all friction drives when exposed to contact should be guarded.

9.16.2 All arm or spoke friction drives and all web friction drives with holes in the web should be entirely enclosed.

9.16.3 All projecting bolts on friction drives where exposed to contact should be guarded.

9.17 Keys, Set Screws and Other Projections

9.17.1 All projecting keys and set screws, and other projections in rotating parts shall be removed or made flush or guarded by guards made of metal or other material of equal strength. This does not apply to keys or set screws within gear or sprocket casing or other enclosures nor to keys, set screws or oil cups in hubs of pulleys less than 50 cm in diameter where they are within the plane of the rim of the pulley.

9.17.2 It is recommended, however, that no projecting set screws or oil cups be used in any rotating pulleys or part of machinery, even though they are within the limits stated in **9.17.1**.

9.18 Collars and Couplings

9.18.1 All rotating collars, including split collars, should be cylindrical and screws or bolts used in collars should not project beyond the largest periphery of the collar.

9.18.2 Shaft couplings should be so constructed as to present no hazards from bolts, nuts, set screws, or rotating surfaces.

9.18.3 Bolts, nuts and set screws will, however, be permitted where they are covered with safety sleeves or where they are used parallel with the shafting and are countersunk or else do not extend beyond the flange of the coupling.

NOTE — While the use of a rib or clamp type coupling is not recommended, they will be acceptable if the ends of the fastenings be well within the periphery of the body of the coupling and the ends of all bolts are flush with or below the crown of the nut. All outside surfaces are to be turned or ground and outside edges carefully rounded.

9.18.4 The shifting part of jaw clutches, and the shifting or mechanism part of friction clutch coupling should be attached to the driven shaft, that is, the shaft that will be idle when clutch is disengaged.

9.19 Starting and Stopping Devices — Clutches, cut-off couplings, or clutch pulleys having projecting parts, where such clutches are located 2.60 m or less above the floor or working platform, should be enclosed by a fixed guard constructed in accordance with 7.

NOTE 1 — Where clutches, cut-off couplings, or clutch pulleys are so situated within a machine or otherwise guarded by location, the application of this rule may not be mandatory.

NOTE 2 — In engine room, a guard rail, preferably with toe board, will be permitted instead of the above provided this room is occupied only by engine room attendant.

NOTE 3 — A bearing support immediately adjacent to friction clutch or cut-off coupling should have self-lubricating bearings, requiring attention at infrequent intervals.

9.20 Belt Shifter, Clutches, Perches and Fasteners

9.20.1 Fast and loose pulley drives should be equipped with a permanent belt shifter provided with mechanical locking means to prevent belt from creeping from loose to fast pulley.

9.20.2 Belt shifter and clutch handles should be rounded and be located as far as possible from danger of accidental contact, but within easy reach of the operator. Where belt shifters are not directly located over a machine or bench, the handles should be cut off 195 cm above floor level.

9.20.3 All belt and clutch shifters of the same type in each shop should move in the same direction to stop machines. This does not apply to friction clutch on counter shaft carrying two clutch pulleys with open and

IS : 9474 - 1980

crossed belts, respectively. In this case the shifter handle has three positions and the machine is at a standstill when clutch handle is in the neutral or middle position.

9.20.4 Where loose pulleys or idlers are not practicable, belt perches in the form of brackets, should be used to keep idle belts away from the shafts. Perches should be substantial and designed for the safe shifting of belts.

9.21 Belt Fasteners — Belts less than 15 cm in width which of necessity must be shifted by hand and belts within 2.60 m of the floor or working platform which are not guarded should not be fastened either with metal in any case or with any other fastening which by construction or wear will constitute an accident hazard.

APPENDIX A

(Clause 3.1)

TYPES OF MECHANICAL MOTION

A-1. ROTARY MOTION

A-1.1 Single Parts

A-1.1.1 Shafts

25

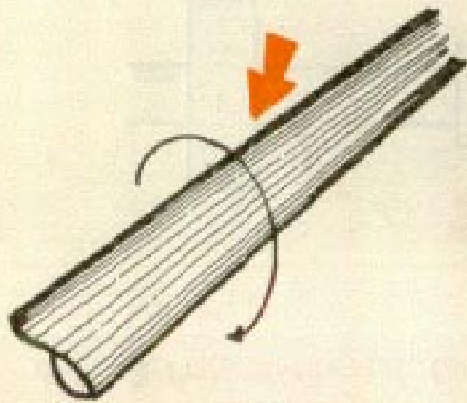

(a)

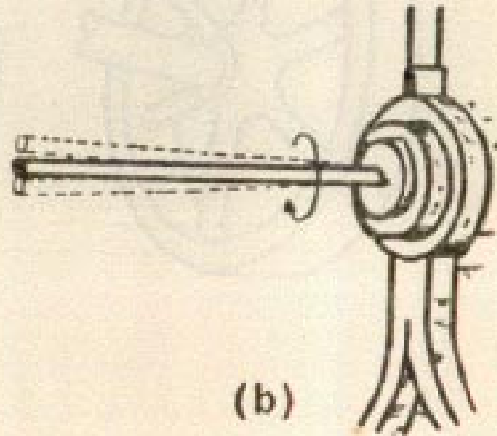

(b)

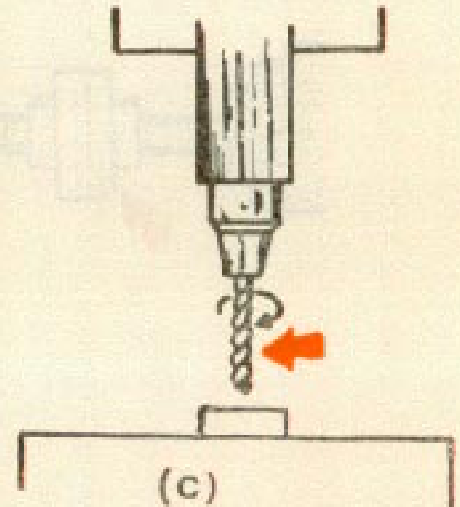

(c)

a) Shaft b) Bar stock c) Chuck

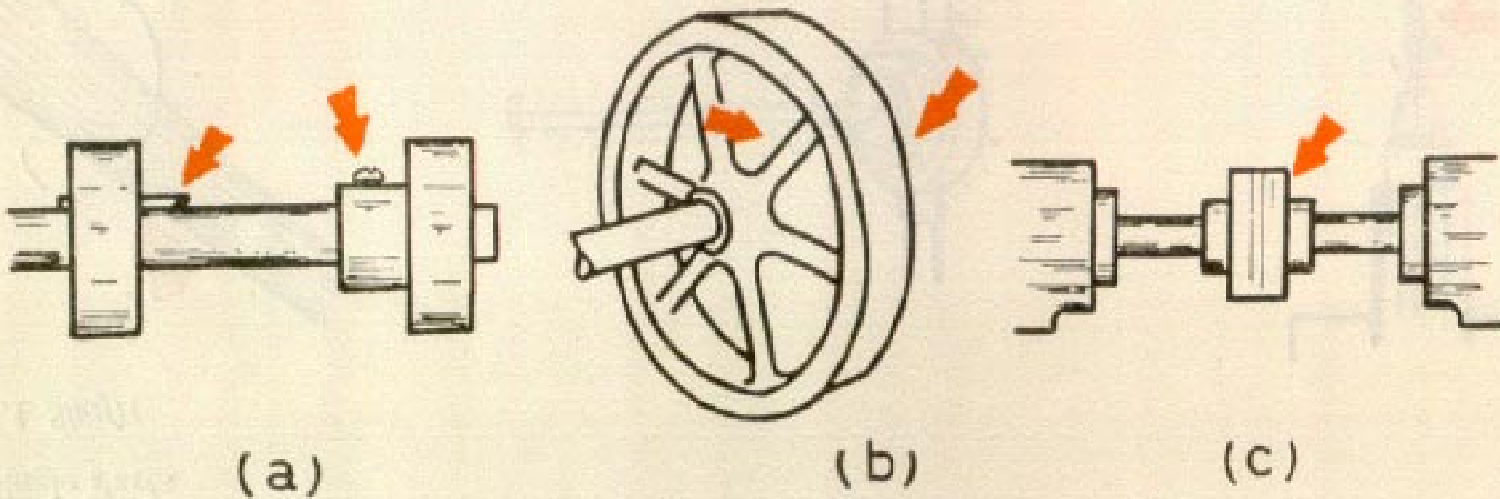
A-1.1.2 Projections and Apertures

- (a) Shaft and pulleys with projecting key and set screw,
(b) Pulley with spokes and projecting burr on face of pulley, and
(c) Coupling with projecting bolt heads.

A-1.1.3 Abrasive and Cutting Tools

27

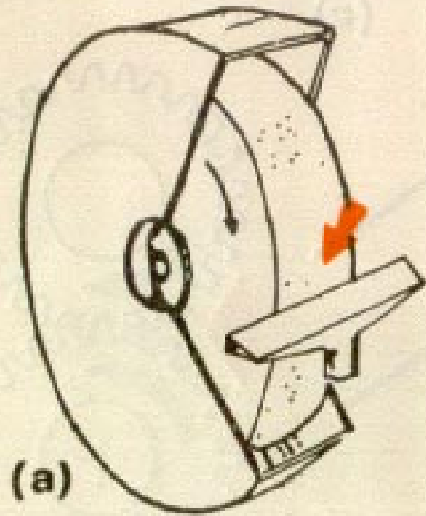

(a)

- a) Abrasive wheel
- b) Milling cutter
- c) Circular saw

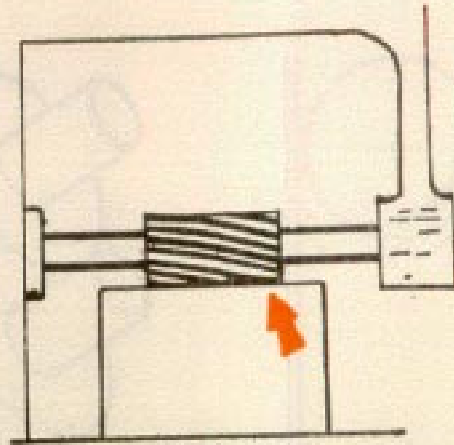

(b)

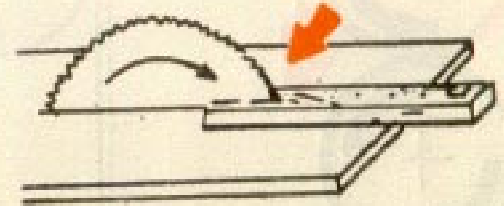

(c)

A-1.2 In-Running Nips

A-1.2.1 Between Parts Rotating in Opposite Directions

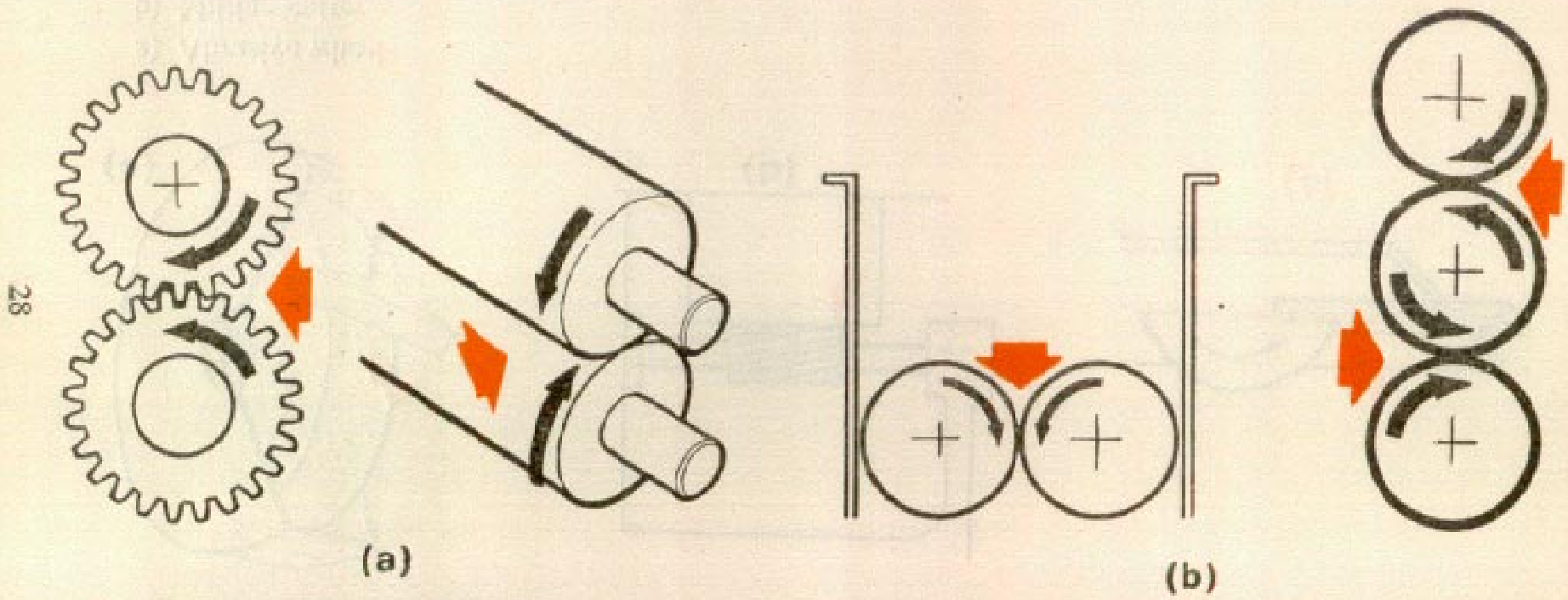

28

(a)

(b)

- a) Gear wheels
- b) Rolls

A-1.2.2 *Between Rotating and Tangentially Moving Parts*

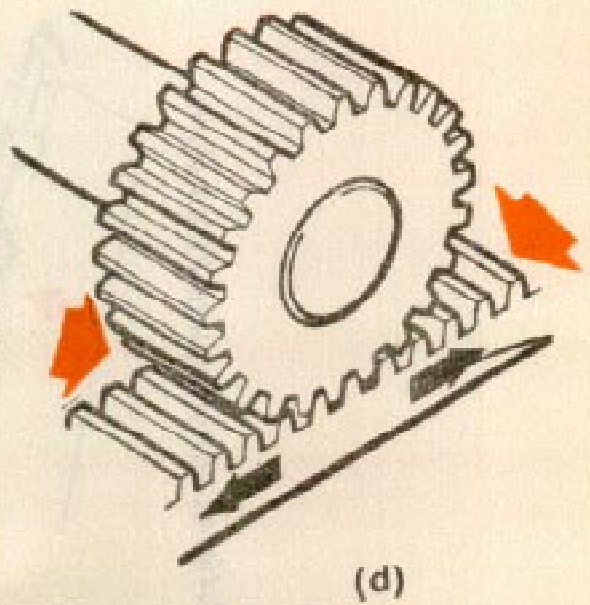
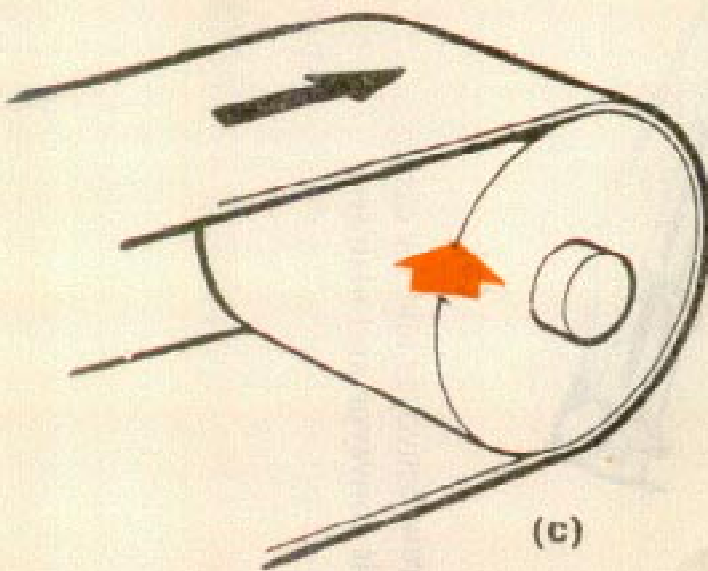
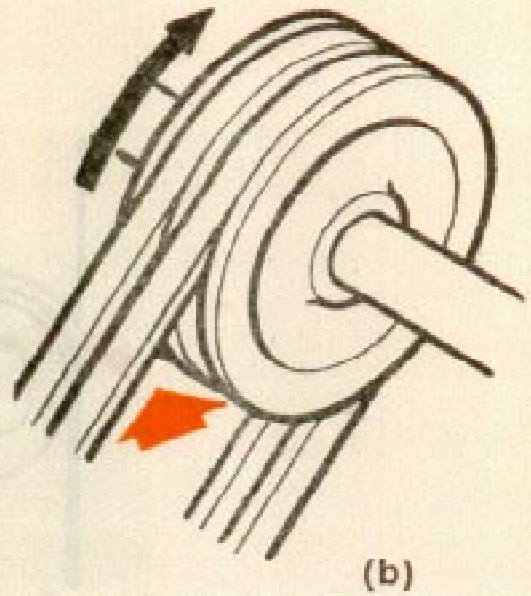
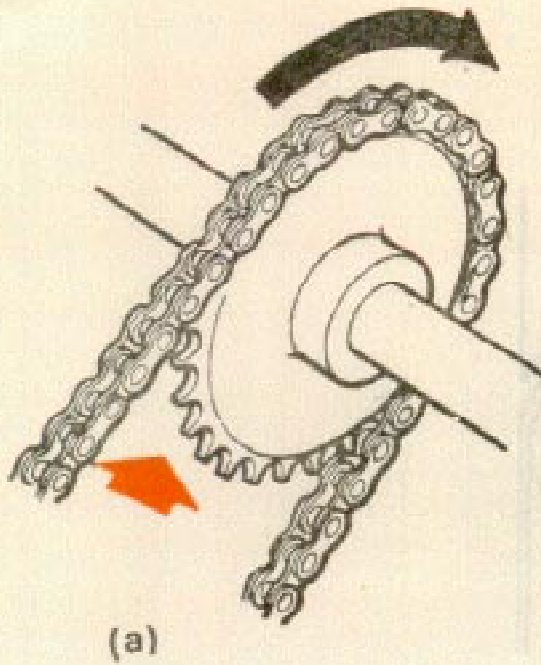

- a) Chain and chain wheel
- b) & c) Pulley and belt
- d) Rack and pinion

A-1.2.3 *Between Rotating and Fixed Parts*

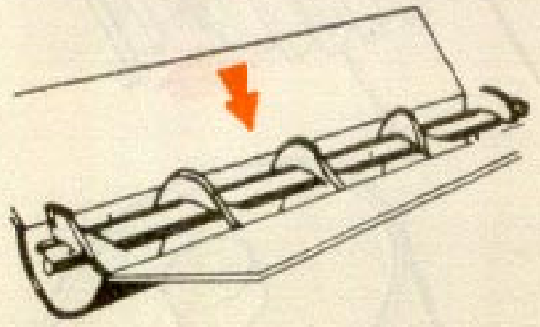

(a)

- a) Screw conveyer and its casing
- b) Belt conveyer and platform

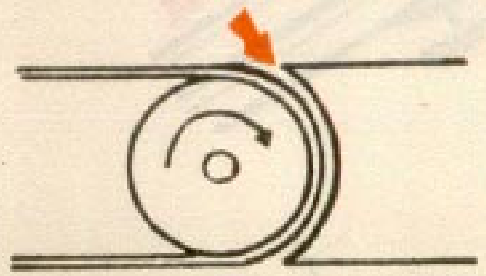

(b)

A-2. RECIPROCATING OR SLIDING MOTION

A-2.1 Reciprocating or Sliding Motions and Fixed Parts

A-2.1.1 Approach Type

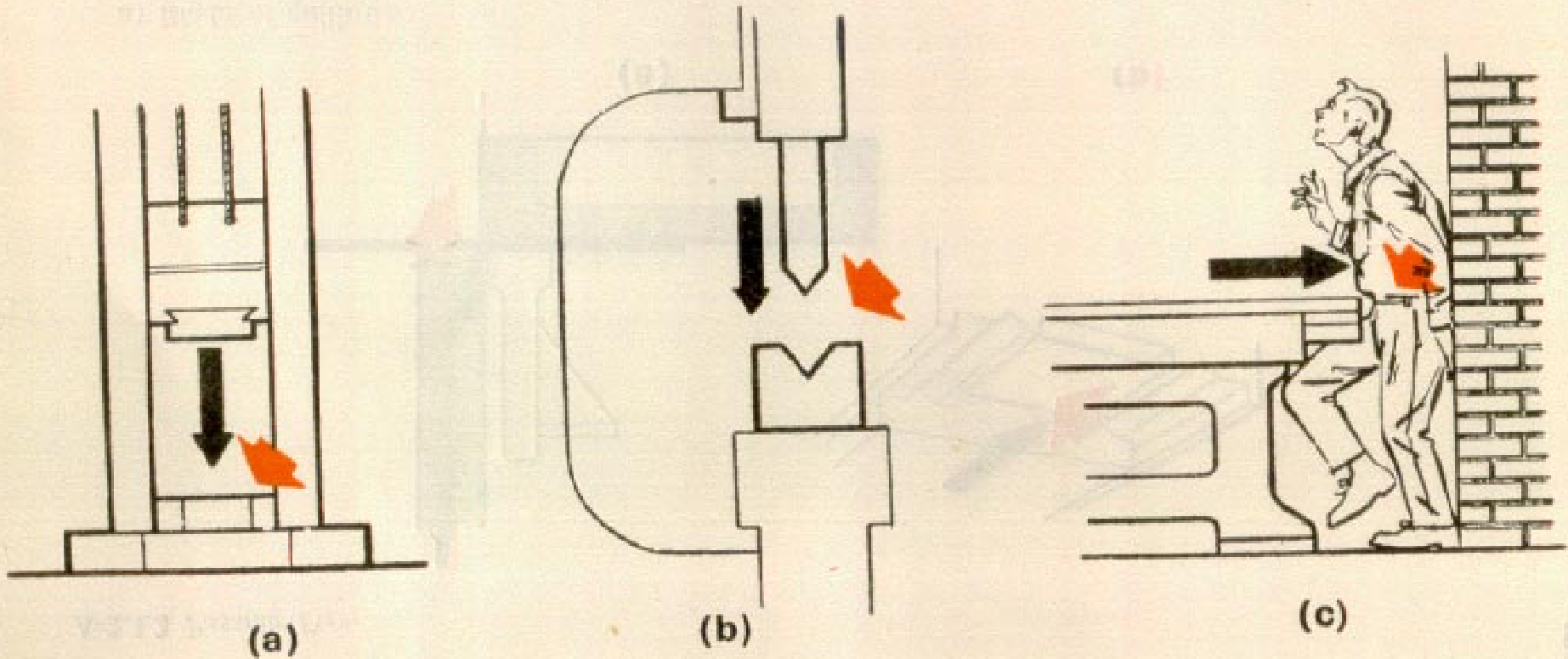

31

- a) Ram of a forging hammer
- b) Slides of power press
- c) Table of a machine tool and a fixed structure

A-2.1.2 *Passing Type*

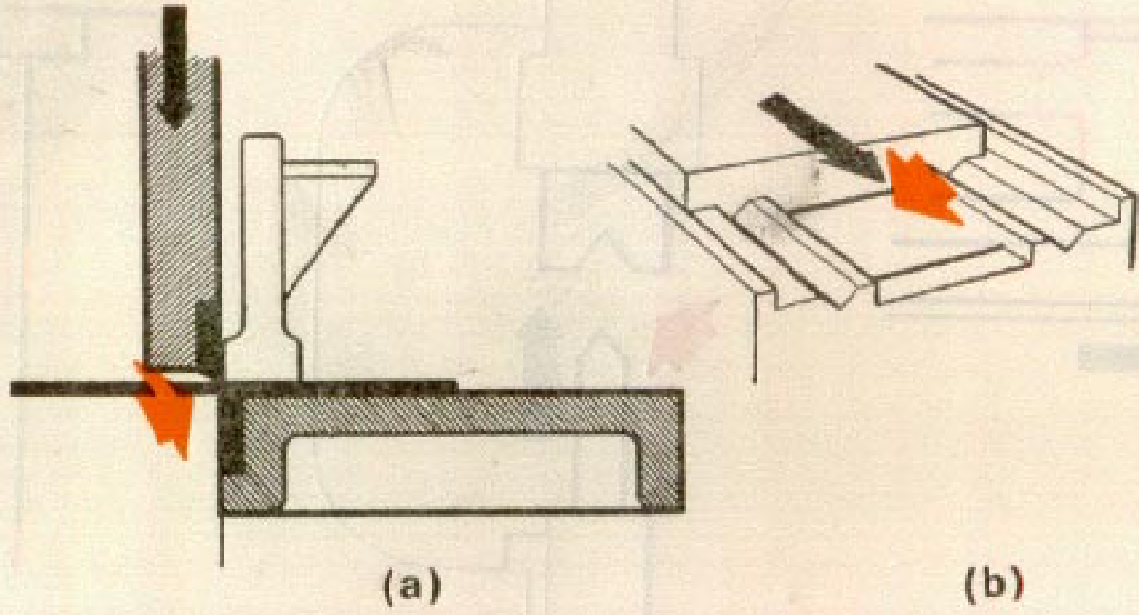

- a) Blade of guillotine
- b) Table of a planing machine and its bed

A-2.1.3 Single Sliding Motion

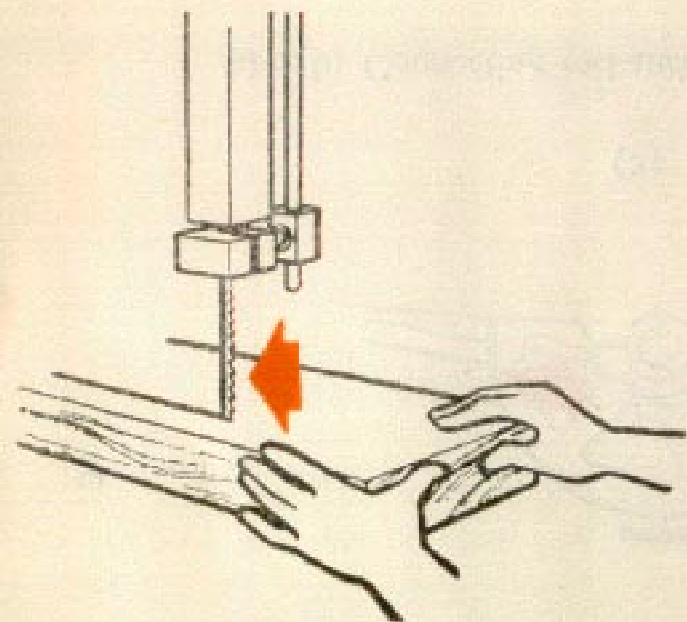

(a)

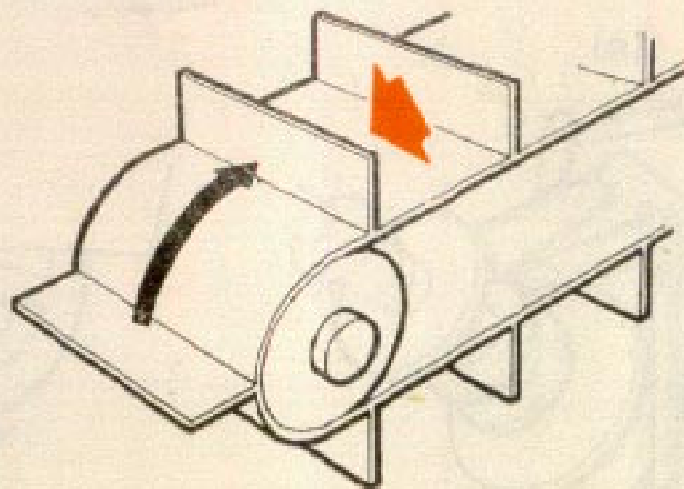

(b)

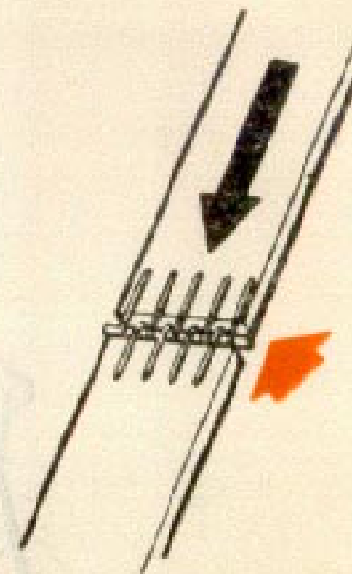

(c)

- a) Teeth on a band saw blade,
- b) Abrasive particles on a belt sanding machine, and
- c) Projecting belt fasteners

A-3. ROTATING/SLIDING MOTIONS

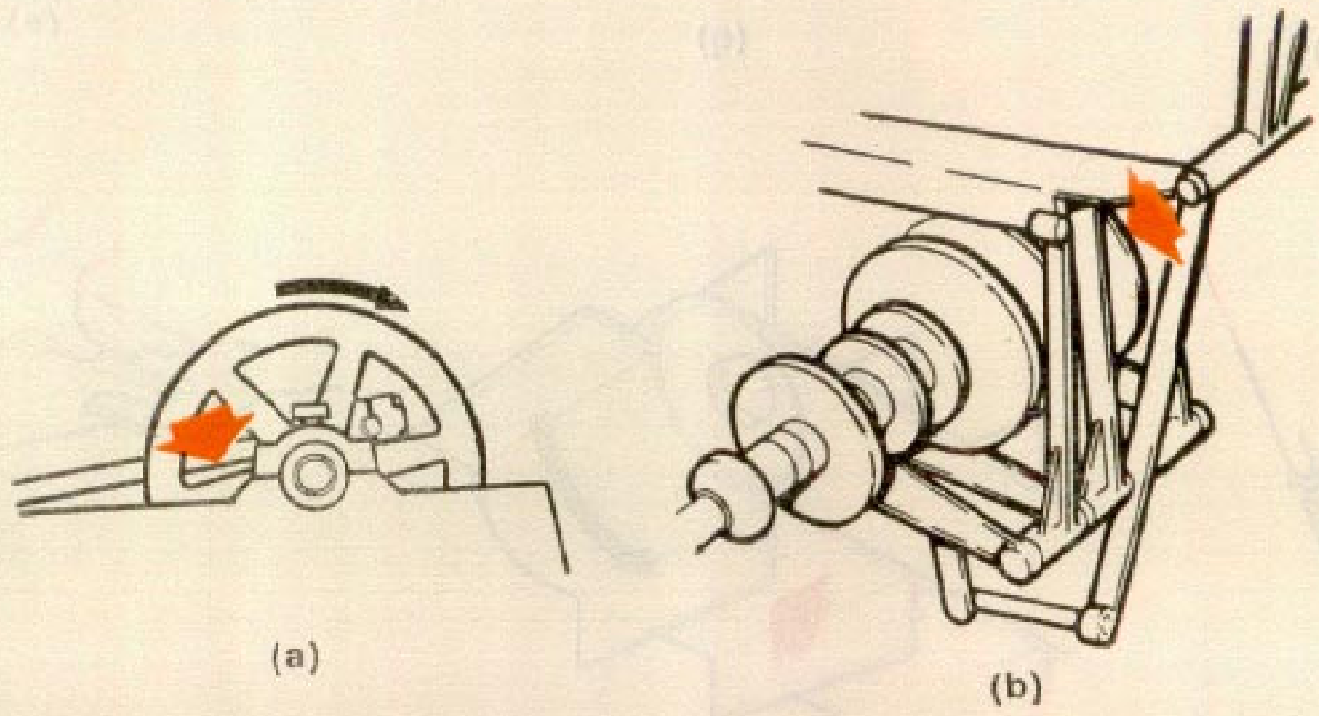

a) & b) Connecting rod and rotating wheel

A-4. OSCILLATING MOTIONS

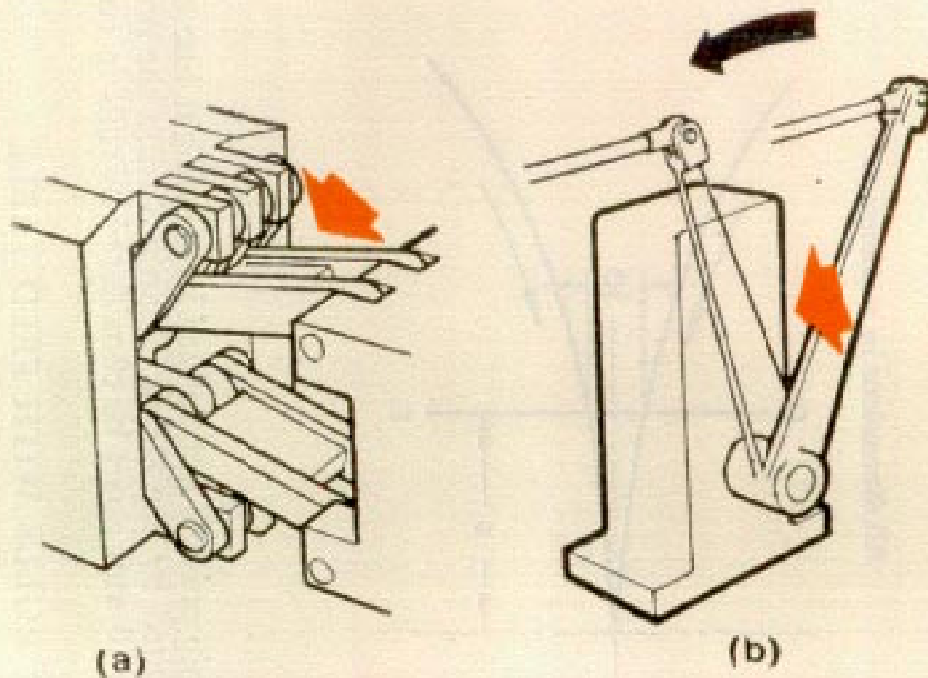

- a) Lattice construction of a lift gate
- b) Arms of open-arm tensioning pulley

APPENDIX B

(Clause 5.1.6)

DESIGN OF PROPERLY PLACED FIXED GUARDS FOR IN-RUNNING NIPS OF ROLLS

B-1. DETERMINATION OF NIP ZONE ON ROLLS

All dimensions in millimetres.

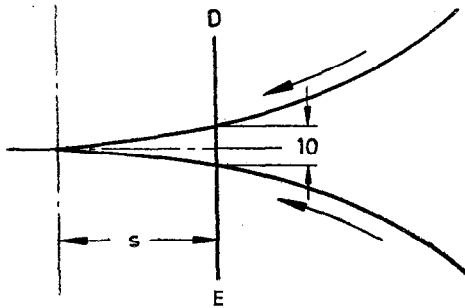

On rolls, the nip point is not defined by a straight line but by a 10 mm wide nip zone indicated by line *DE* at distance *S* from the point of contact. Rolls held less than 10 mm apart be considered as rolls in contact.

B-2. GUARD FOR ROLLS WITH FEED TABLE

B-2.1 Draw a full scale outline of the nip zone with the top surface of the feed table accurately shown. Indicate the clearance line on the top roll. If more than 10 mm clearance is required, the top edge of the guard should be located in accordance with the safe opening layout for rolls with stock travelling over one of the rolls as in **B-4**.

B-2.2 Determine distance *S*, the distance from the centre line of the rolls to a point where a 10 mm vertical space exists between the top of feed table and the surface of the upper roll as shown in the figure.

All dimensions in millimetres.

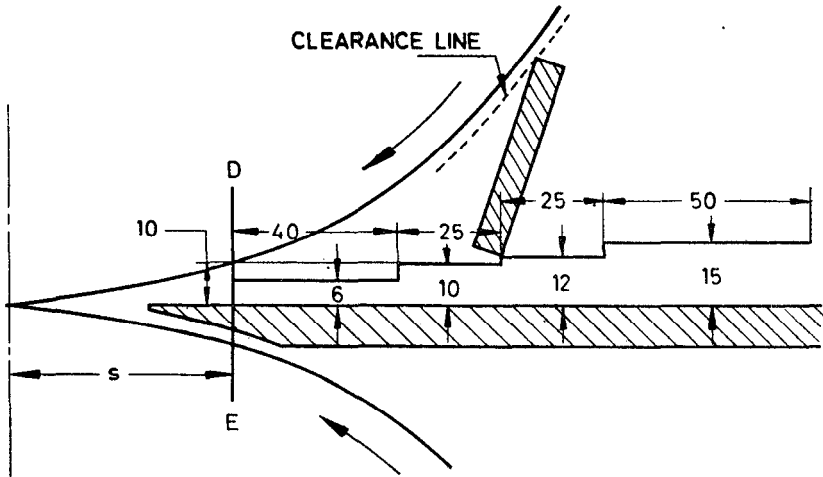

B-2.3 At this distance, start the layout of the safe opening dimensions as shown in Fig. 1 up to the opening necessary for the particular guard being designed. Outline the guard section (top edge on clearance line on upper roll and bottom edge at proper point on safe opening layout) and determine the necessary dimensions for installing the guard. Width of the guard can also be determined.

B-2.4 Before the guard is put in operation, check carefully for hand travel under the guard, stability of mounting, and rigidity of construction.

B-3. GUARD FOR ROLLS WHERE NO FEED TABLE IS USED AND STOCK TRAVELS INTO THE NIP AT RIGHT ANGLES TO THE CENTRE OF THE ROLLS

B-3.1 Draw a full scale outline of the nip zone with the stock travel line accurately shown. Indicate the clearance line on both rolls. If more than a 10 mm clearance is required between the edges of the guard and the rolls, the edges of the guard should be located in accordance with the safe opening layout shown in **B-4**.

B-3.2 Determine distance S , the distance from the vertical line of the rolls in a point where a 5 mm vertical space exists on each side of the travel line of the stock (total nip width of 10 mm) as shown in the figure.

All dimensions in millimetres.

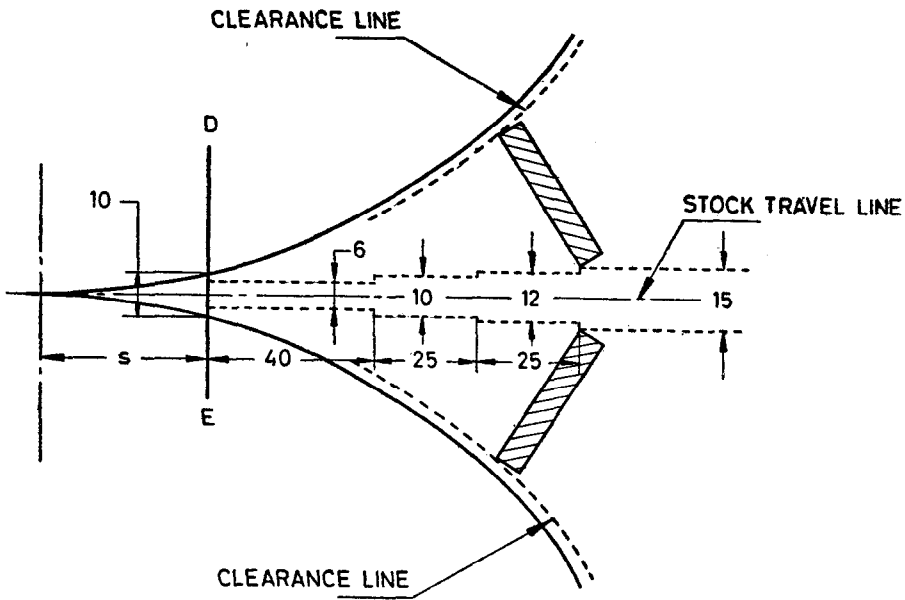

B-3.3 At this point, begin the layout of the dimensions shown in Fig. 1 centred on the travel line of the stock. Outline the guard section, giving the required opening between sections (one edge of each section will touch a clearance line; the other will touch the safe opening layout at the proper point to give the required opening). Determine the necessary dimensions properly locating the guard from this final layout. The width of the guard can also be determined.

B-3.4 Before the guard is put in operation, check carefully for hand travel under the guard, stability of mounting, and rigidity of construction.

B-4. GUARD FOR ROLLS WHERE STOCK TRAVELS OVER ONE ROLL BEFORE ENTERING NIP ZONE

B-4.1 Draw a full scale outline of the nip zone with the travel line of the stock indicated on the roll. Indicate the clearance line on the top roll. If

All dimensions in millimetres.

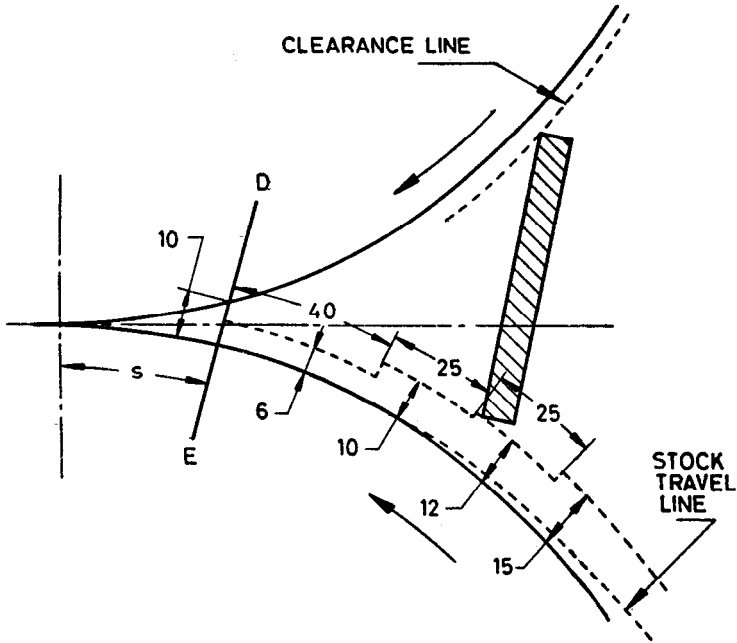

more than a 10 mm clearance is required, the top edge of the guard should be located in accordance with the safe opening layout.

B-4.2 Determine distance S , the distance of the centre line of the roll to the point where there is a 10 mm space between the rolls.

B-4.3 At this distance begin the layout (on the roll with the stock travel) of the safe opening dimensions as shown in Fig. 1. Layout can be made on roll surface with 10 mm divider steps. Outline the guard section (one edge touching clearance line and the other touching the safe opening layout at the proper point to give the required opening). Determine the necessary dimensions for properly locating the guard from this final layout. The width of the guard can also be determined in addition to locating the dimensions.

B-4.4 Before the guard is put in operation check carefully for hand travel under the guard, stability of mounting, and rigidity of construction.

B-5. DIFFERENT DESIGNS FOR A ROLL NIP GUARD WHERE FEEDING OVER OR UNDER A GUARD IS DESIRED

All dimensions in millimetres.

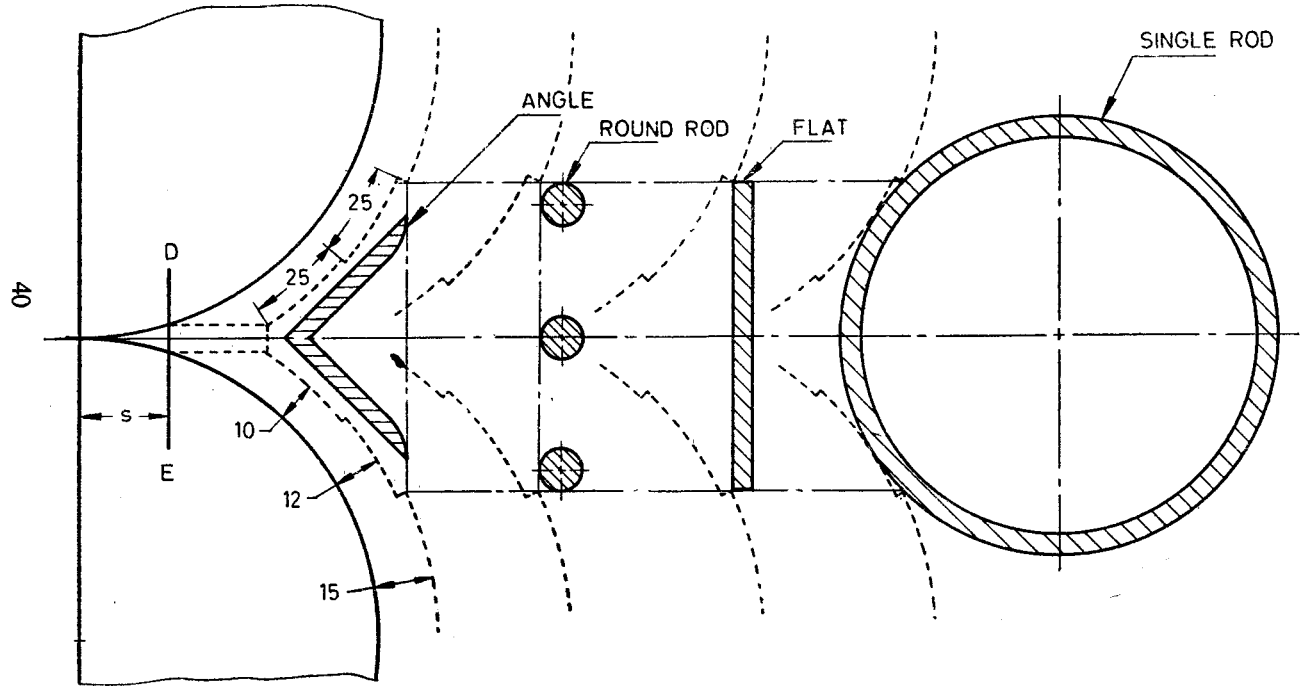

B-6. DIFFERENT DESIGNS FOR A ROLL NIP GUARD WITH FEED TABLE

All dimensions in millimetres.

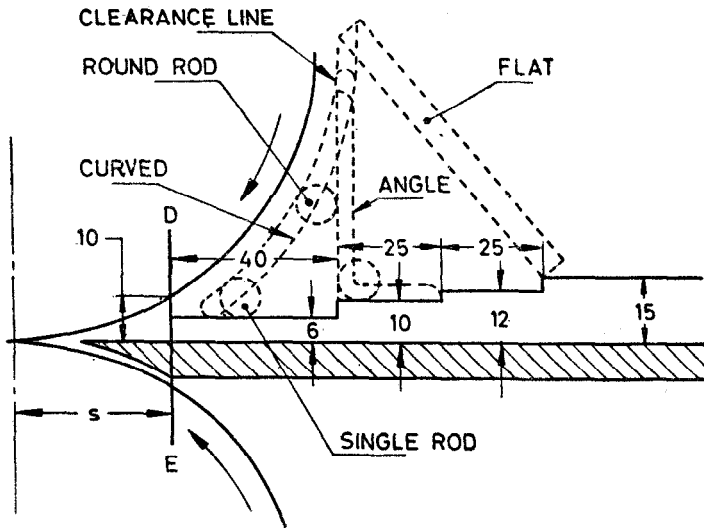

APPENDIX C
(Note Under Clause 7.8)

METHODS OF FIXING PANELLING MATERIAL IN FRAMEWORK

42

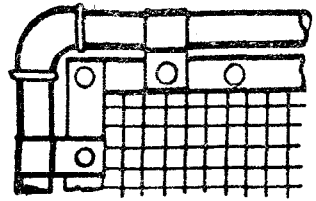

**IRON PIPE GUARD WITH
WIRE CLOTH FILLER**



(SHEET METAL NO 24 OR HEAVIER)

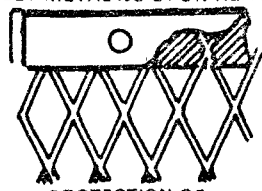

**PROTECTION OF
ROUGH EDGES**

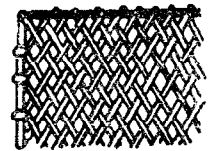
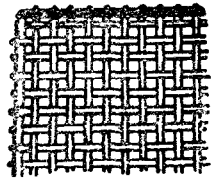

**WOVEN WIRE
MESH 10 mm
ROUND FRAMES**



**PERFORATED OR
SHEET METAL
BOLTED DIRECTLY
TO ANGLE**



**FLAT STRIP RIVETED
(OR BOLTED) TO ANGLE
TO FASTEN FILLER**

APPENDIX D

(Clause 1.1)

EXAMPLES OF TYPICAL APPLICATION OF MECHANICAL GUARDS

D-1. FIXED GUARDS

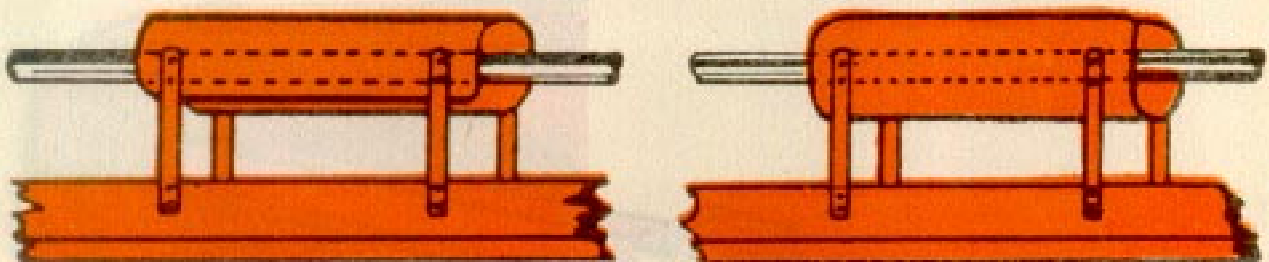
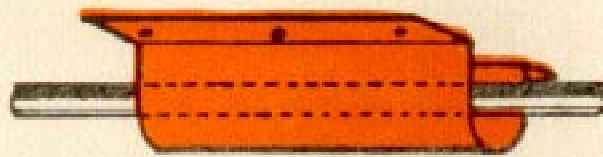

a) Horizontal shafting

(a)

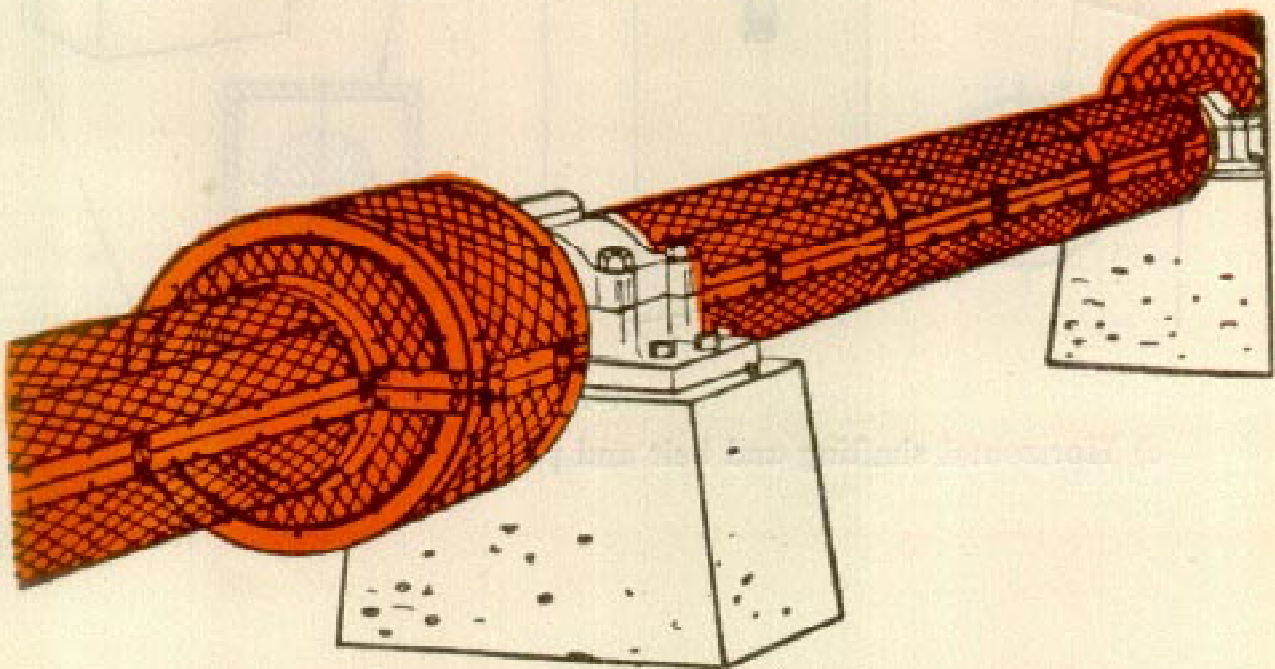

(b)

b) Horizontal shafting

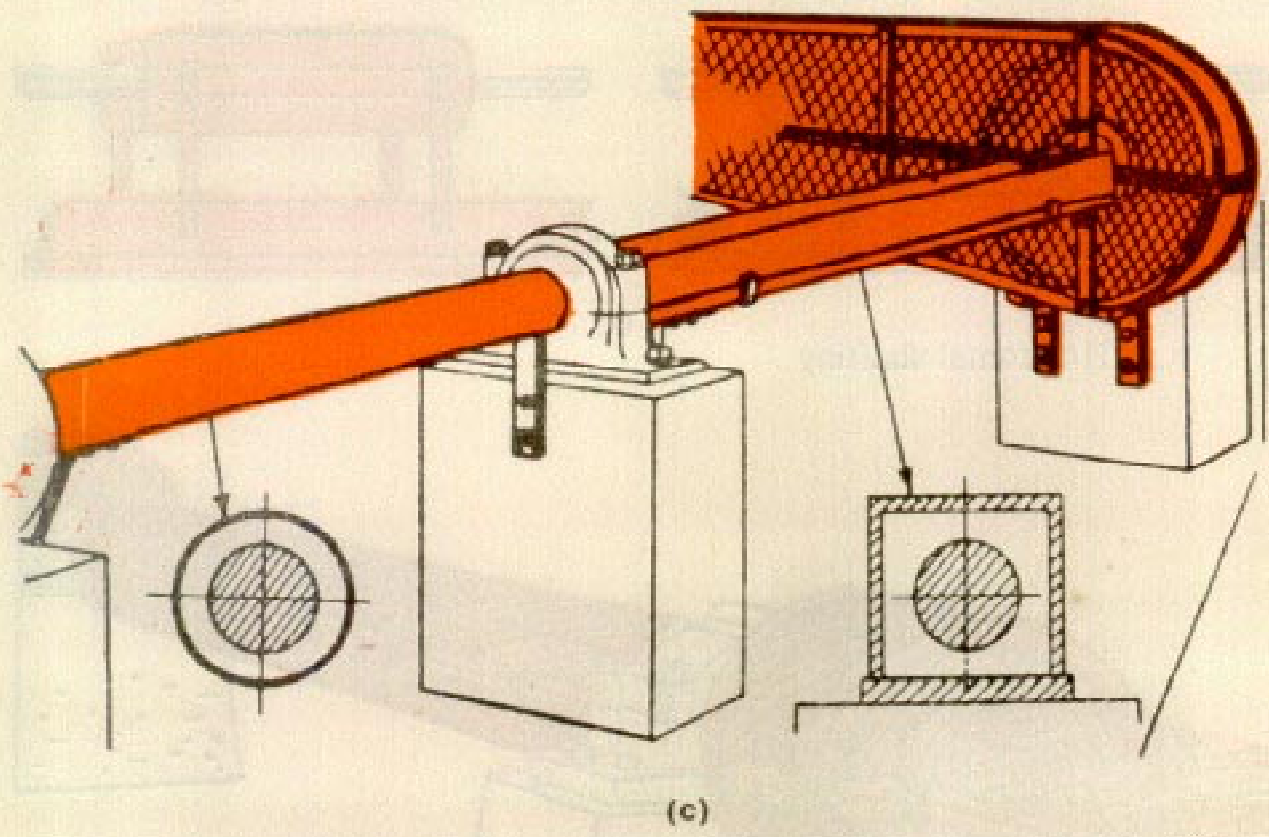

(c) Horizontal shafting and belt and pulley

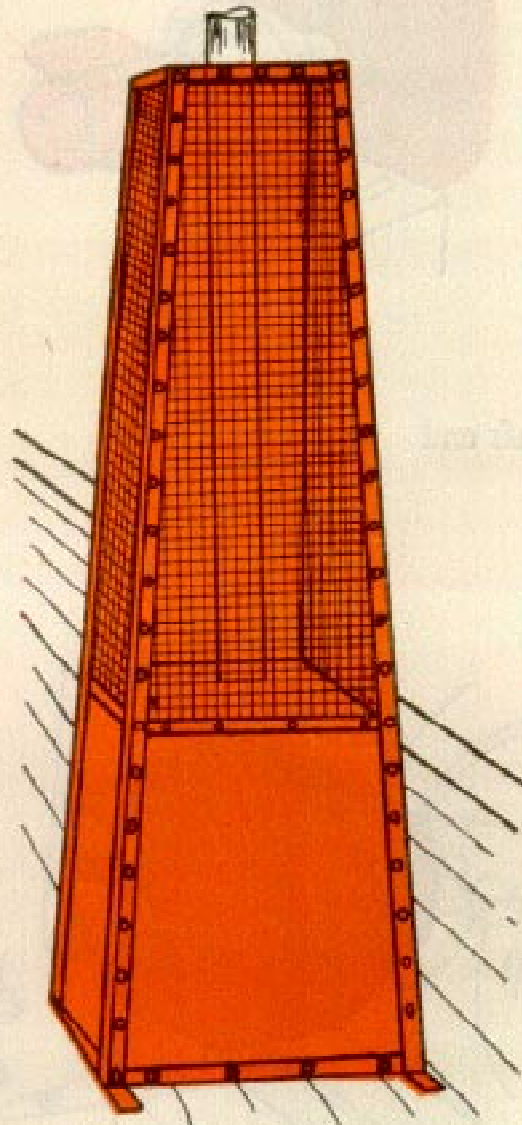

(d)

d) Vertical shafting

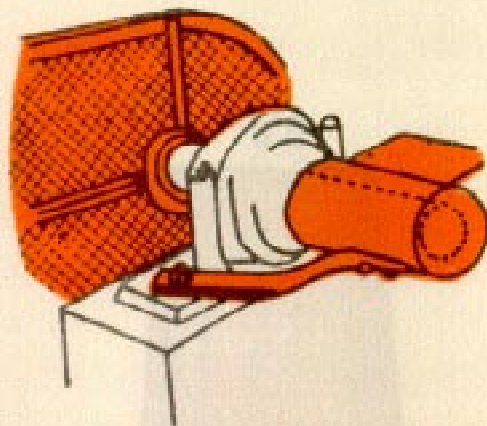

(e)

e) Sleeve for shaft end

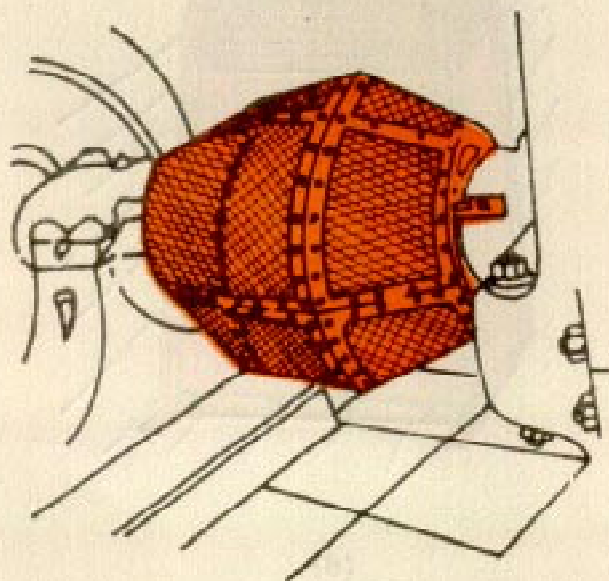

(f)

f) Coupling

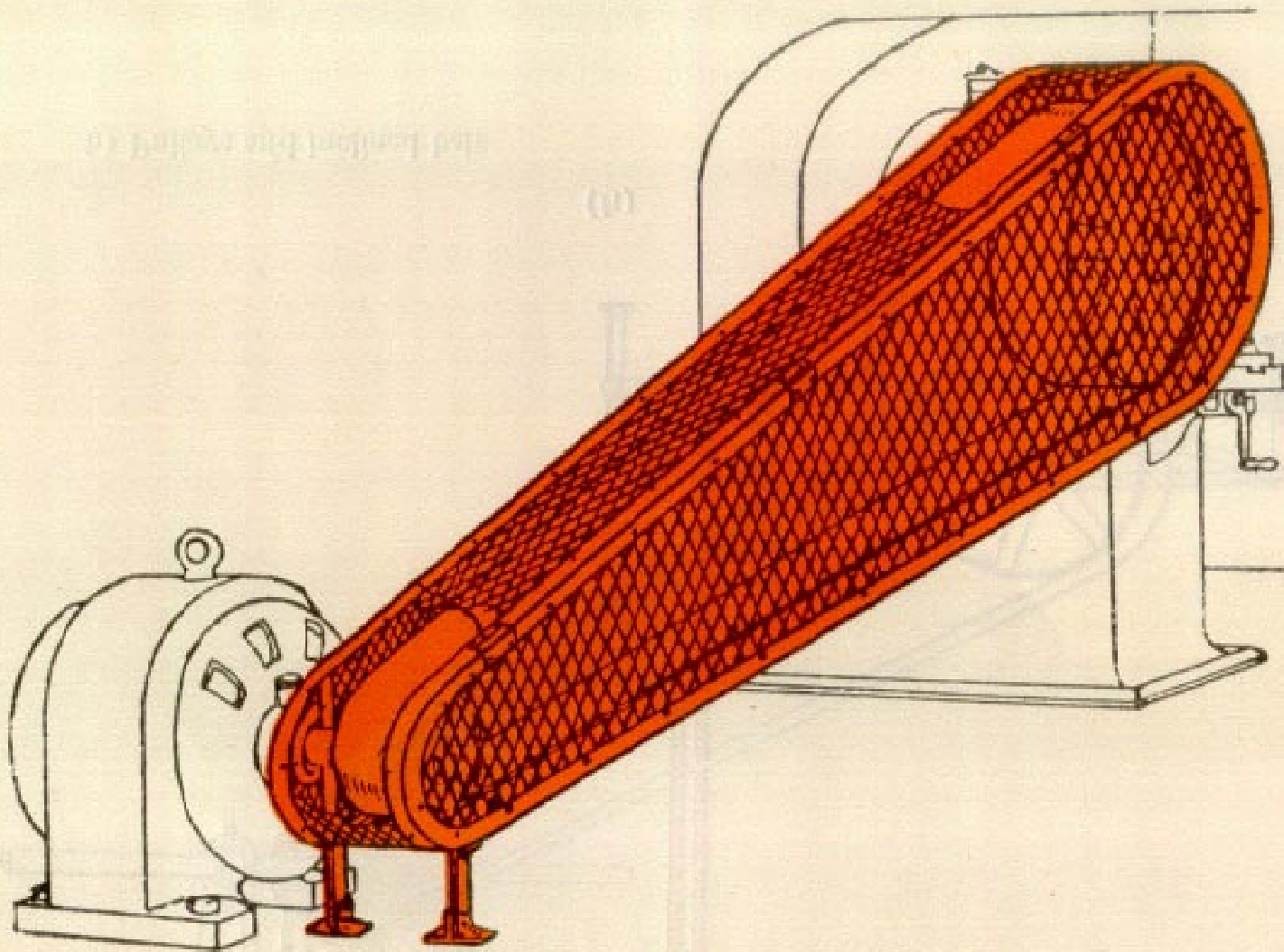

(g)

g) Pulleys with inclined belt

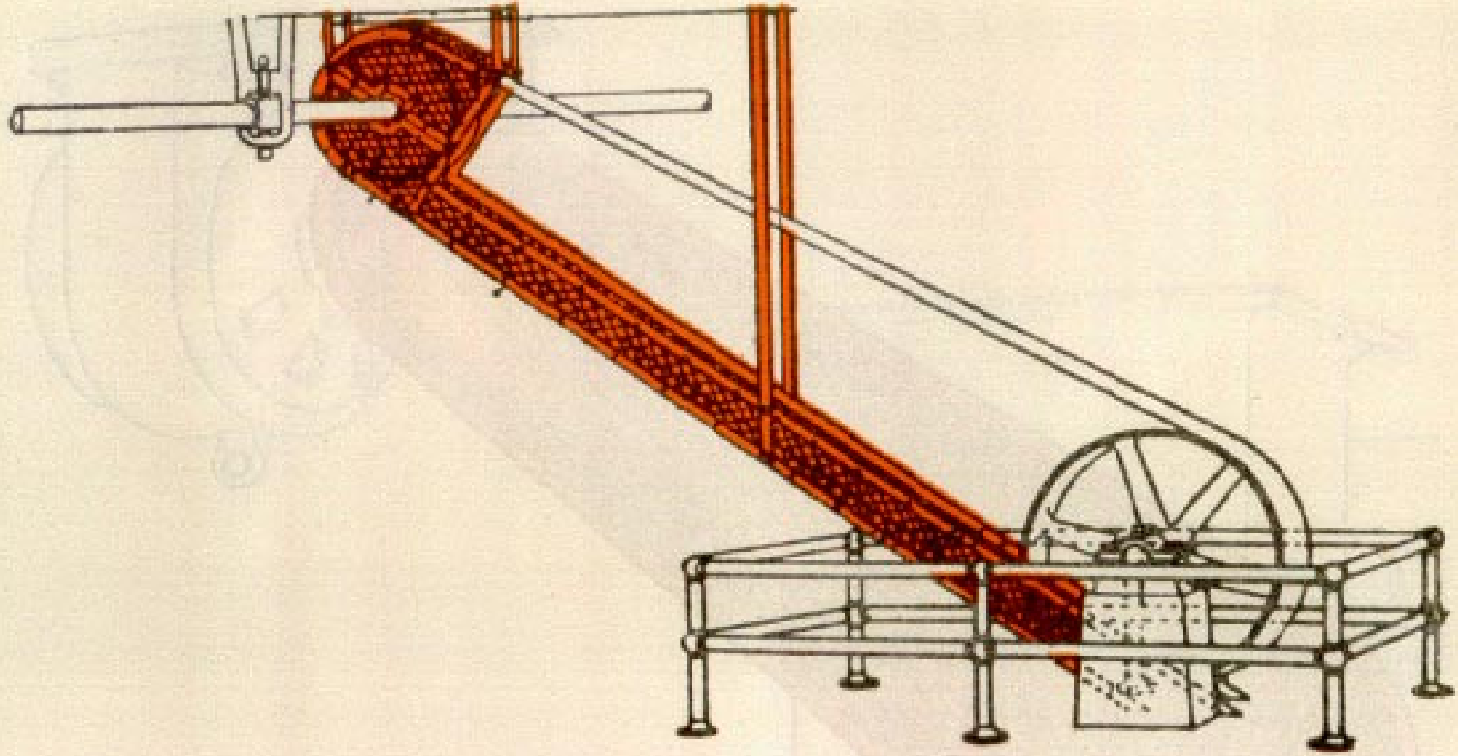

(h)

h) Pulleys and inclined belt

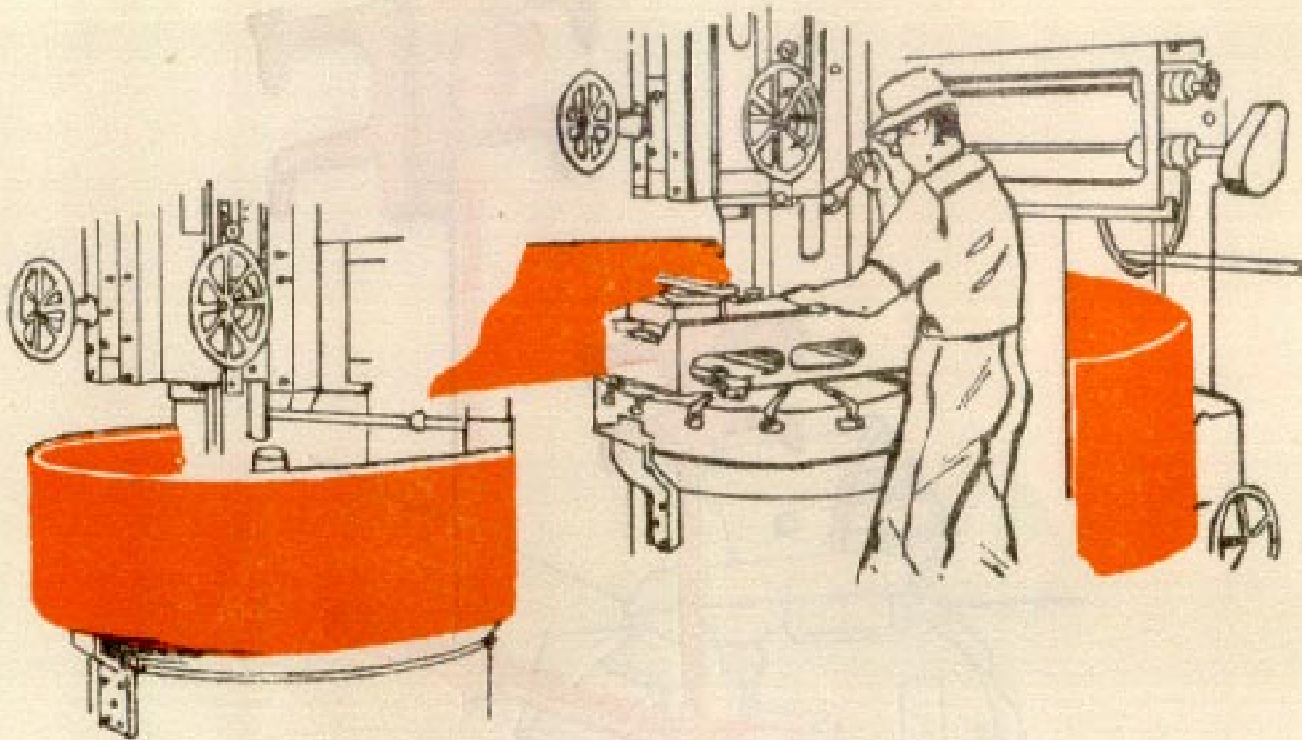

- j) Barrier guard for vertical boring mill-guard is made in two sections, hinges to the machine and easily opened to facilitate setting-up of the machine. It is advisable to prevent the possibility of starting the machine when the guard is open.

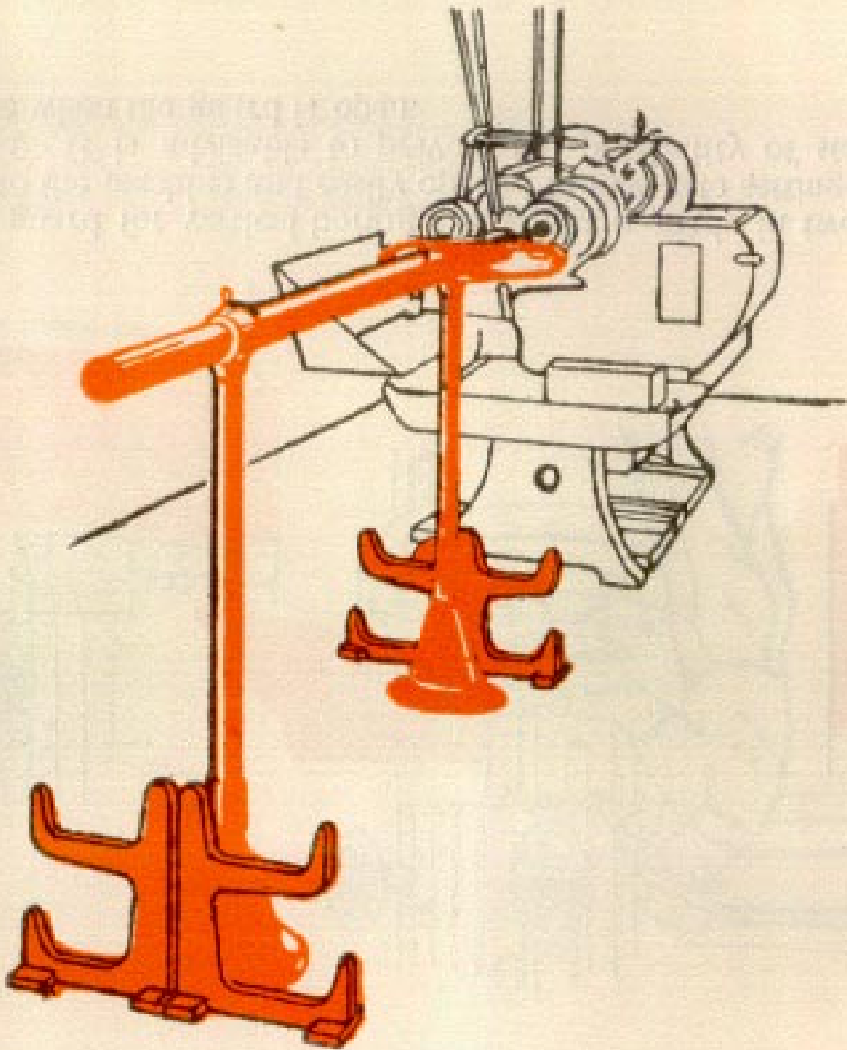

k) Revolving bar stock guard

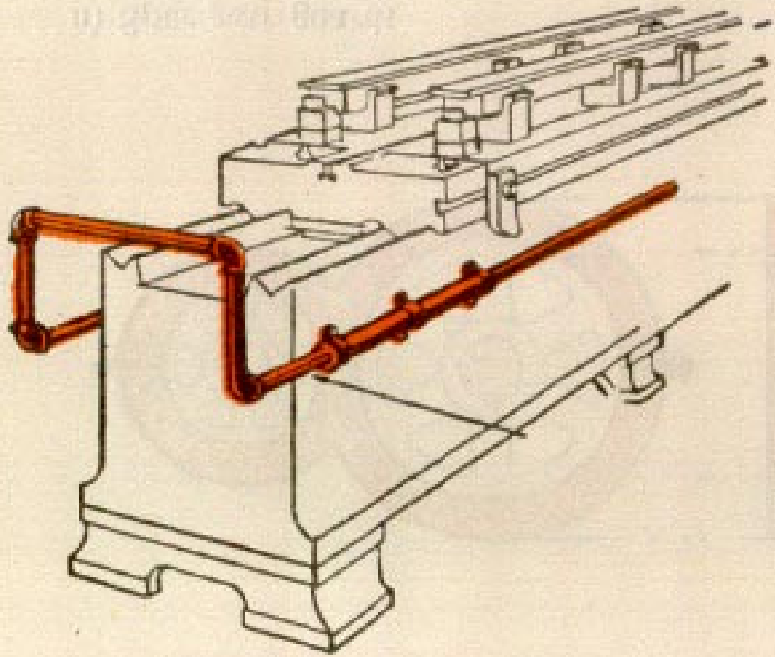

m) Planer table guards

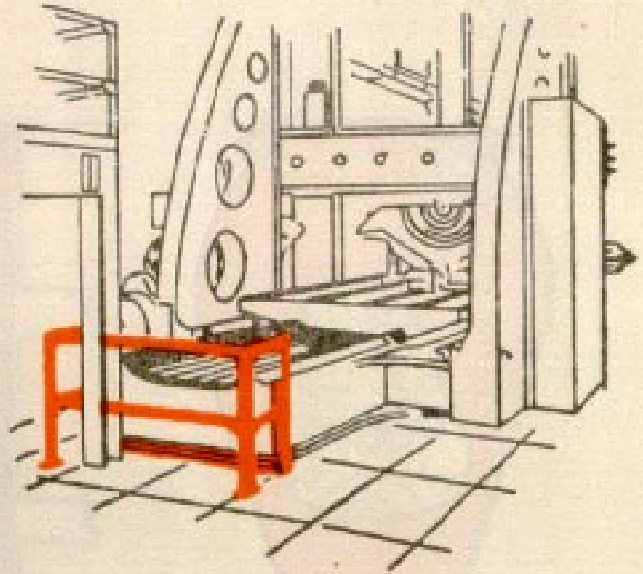

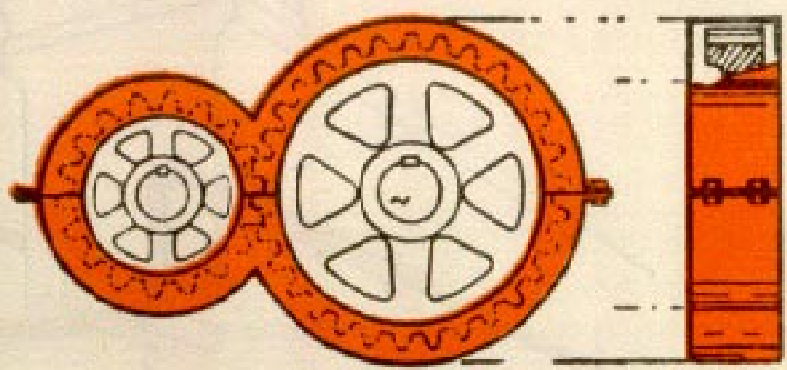
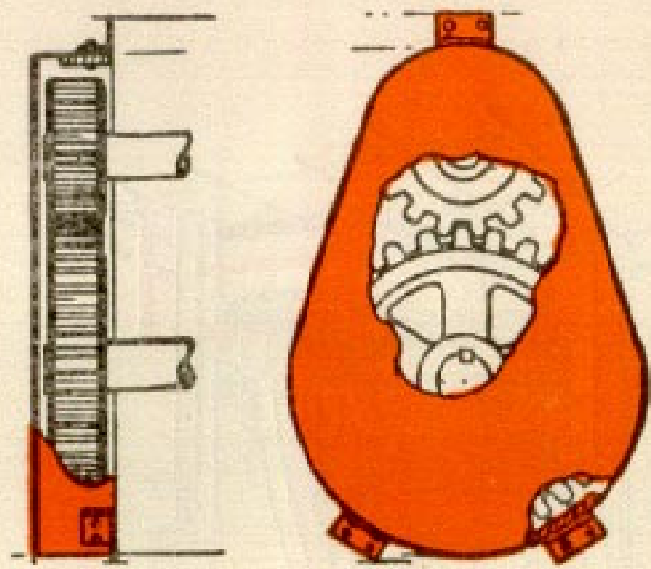

n) Spur gear guards

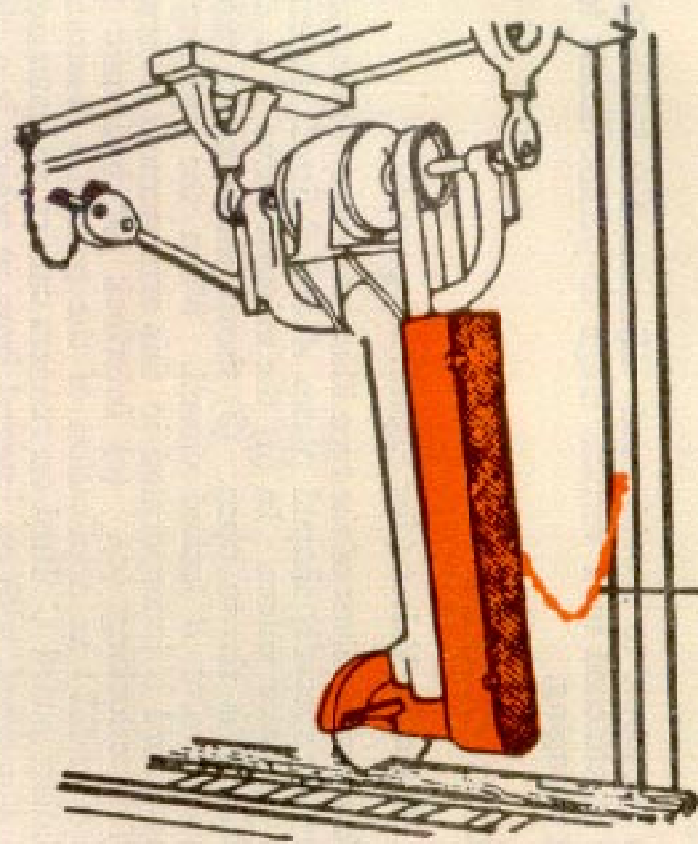
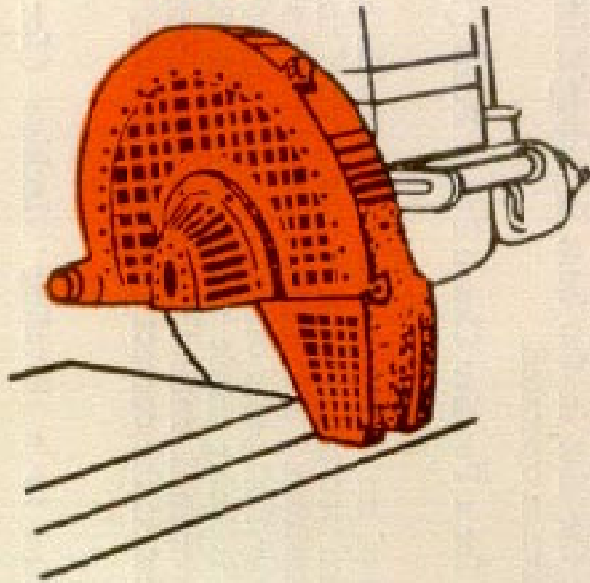

Swing Saw Hood

- p) Swing saw. In addition to the hood enclosing the blade, the swing saw should be provided with a limit chain or other device to limit forward travel and a device to automatically return the head to starting position. Hood should enclose saw.

D-2. ADJUSTABLE GUARD

D-2.1 Adjustable Guard for a Radial or Pedestal Drilling Machine (for Figure, *see* page 58)

The guard is telescopic to provide ready adjustment to the surface of the workpiece and is attached to a vertical hinge to permit access to the spindle for drilling changing.

D-3. INTERLOCKING GUARDS

D-3.1 Interlocking Hydraulic Valves (for Figure, *see* page 59)

Screw down hydraulic valves of the type illustrated may be interlocked with one another by the specially shaped plates *A* and *B* fitted respectively to the exhaust and pressure valves. In (a) the exhaust valve *A* is closed and the pressure valve *B* is shown open. (b) shows the exhaust valve *A* open and the pressure valve *B* locked closed. When the opening and closing of a sliding guard is incorporated in this arrangement it forms an efficient method of interlocking (c). (c) Interlock for hydraulic press with sliding guard (*see* 5.2) an application of the principle illustrated in (a) and (b). A sliding guard *C* fitted on runners carries an extension *D*. The exhaust valve *A* is fitted with an integral boss in which is a slot of sufficient width to accommodate the guard extension *D*. In the position shown the exhaust valve *A* is open and the slot in the boss is ready to accommodate the guard extension *D* when it is opened by sliding it to the left. On completion of this action the pressure valve *B* cannot be opened and the exhaust valve *A* cannot be closed. A stop (not shown) should be provided to ensure that the slot in the boss is brought into the correct position each time the valve is operated.

D-3.2 Interlocking Guard for a Positive Clutch Power Press (for Figure, *see* page 60)

The guard consists of an enclosure with a movable gate *A*. When the gate is closed the guard prevents access of any part of the body to the danger area from any direction. The gate is interlocked with the clutch mechanism *B* in such a way that press cannot operate until the gate is fully closed. While a stroke is being made the gate is held closed by guard control *C* and cannot be opened until the clutch has disengaged and the crankshaft has come to rest at the correct stopping position, usually at top dead centre.

D-3.3 Sensing Guard Fitted to a Riveting Machine (for Figure, *see* page 61)

The guarding of a riveting machine presents a particular difficulty in that the operator has to hold the workpiece on the anvil while the tool

descends. Complete enclosure by means of a fixed guard or a conventional interlocking guard is, therefore, usually impracticable. The illustration shows a guard consisting of a sensing ring *A* which surrounds the tool and which offers no obstruction, either physical or visual, to the operator while he is locating and holding the workpiece on the anvil. Depression of the operating pedal lowers the sensing guard to the working position, which is adjustable so that the lower edge of the guard is just clear of the workpiece. Provided the guard is not obstructed by the operator's fingers; as it descends, linear cam *B* allows limit switch *C* to operate and a solenoid operated clutch to engage and cause the tool to descend under power. Should the sensing guard be obstructed by a finger, or otherwise fail to reach the pre-set position, the machine will not operate. In some sensing guards electrical control is replaced by either a mechanical linkage or a pneumatic system.

D-3.4 Example of the Use of a Trapped Key Interlock System (for Figures, see pages 62 and 63)

At an internal mixing machine, used in the processing of rubber, key exchange interlocking provides the only practicable means of preventing access to a number of widely separated danger areas. The principle employed is that all sources of power are isolated, and all stored energy is dissipated, before access is possible.

Interlocking is achieved by means of a mainkey exchange box (*a*) into which all isolating keys have to be inserted before any access key can be released. When a guard is open an access key is trapped in it, likewise, when a part controlled by an isolating key is live, the key remains trapped in it. For example, before the rear inspection door (*b*) can be unlocked and opened, the compressed air supply has to be locked shut, with both ends of the floating weight cylinder vented to atmosphere and the floating weight supported on a scotch pin which is locked in position. In addition the isolator for the main and hydraulic pump motors has to be locked open and the rotors at rest. This latter condition is achieved by a time delay unit which will release an isolating key for the main exchange box only after sufficient time has elapsed for the motor to come to rest.

Access to the other dangerous part is obtained by a similar process.

D-4. AUTOMATIC GUARD

D-4.1 Automatic Guard for a Power Press (for Figures, see pages 64 and 65)

This guard, which is connected to the moving part of the press, is designed to remove the operator from the danger area before he can be trapped. (*a*) shows the press at top dead centre and the guard in the inner position giving free access for loading and unloading the workpiece. As the press ram descends the guard moves out to the position shown in (*b*) where it prevents the operator from reaching the danger area.

D-5. DISTANCE GUARD

D-5.1 Distance Guard Fitted to a Press Brake (for Figure, *see* page 66)

The guard consists of a pair of side frames in the lower parts of which three rollers *A* are fitted, together with a pair of tubular rails *B* running across the front of the machine and supported by the side frames. The position of the front frame is so arranged that fingers cannot reach the danger area. The side frames are filled with solid guarding *C*. The upper front rail can be made to telescope within the upper tubes *D* of the side frames so that the guard can be moved further from the dies to accommodate larger sheets. Side and rear guards are not shown in the illustration.

D-6. TRIP GUARD

D-6.1 Distance Bar Trip Guard (for Figures, *see* pages 67 and 68)

The trip bar *A* is so connected to the machine controls that it has to be pulled out from the danger area *B* a specified distance before the machine can be operated. The illustration shows the guard fitted to a mechanical press brake, with a work table *C* to assist work handling. The bar is locked in the safe (out) position by hook *D* which engages arm *E*, the hook being released when the beam *F* has returned to the top of its stroke. The bar is sensitive so that pressure against it in the out position disengages the clutch.

D-6.2 Safety Trip Bar for Horizontal Two-Roll Mills Used in the Rubber Industry (for Figure, *see* page 69)

Movement of the trip bar *A* towards the front roll switches off the drive to the rolls by means of limit switch *B* and applies a brake. The position of the trip bar is important. Its height above the floor and its horizontal distance from the inrunning nip should be such that the operator cannot reach beyond the safety limit *C* which is dependent on the efficiency of the brake, making allowance for brake wear. After the trip bar *A* has been tripped the brake should arrest the motion of the rolls before a hand can be drawn into the nip.

D-6.3 Horizontal Trip Wire Fitted to a Radial Drilling Machine (for Figure, *see* page 70)

Deflection of the trip wire *A* operates a switch which cuts off the power supply and applies a brake. The trip wire is suspended between the ends of a frame which is adjustable in height to suit the job in hand.

D-6.4 Photo-Electric Trip Device Providing a Curtain of Light Which Can be Arranged in Either a Horizontal (*A*) or Vertical (*B*) Configuration (for Figure, *see* page 71)

Interruption of the curtain while the dangerous parts of the machine are moving results in a signal being given for the machine to stop. The

speed of stopping should be such as to ensure that the dangerous parts have come to rest before they can be reached by the operator. Access to the danger area from any direction not protected by the device should be prevented by effective fixed or interlocking guards.

D-6.5 Pedal Operated Control Valves and Switches Protected from Accidental Operation by Means of a Cover (for Figures, *see* pages 72 and 73)

Where possible the entire length of the pedal and its lever should be covered to prevent any part from being struck by material. Side panels prevent accidental operation through sliding the foot across the pedal and under the cover.

D-7. TWO-HAND CONTROL

D-7.1 Two-Hand Control (for Figure, *see* page 74)

At some machines the use of a guard is impracticable and other measures to protect the operator are necessary. The provision of two-hand controls at this clicking press used in the manufacture of footwear ensures that the operator has both hands in a safe position while the press head descends. To protect against accidental operation the buttons should be shrouded (*see inset*).

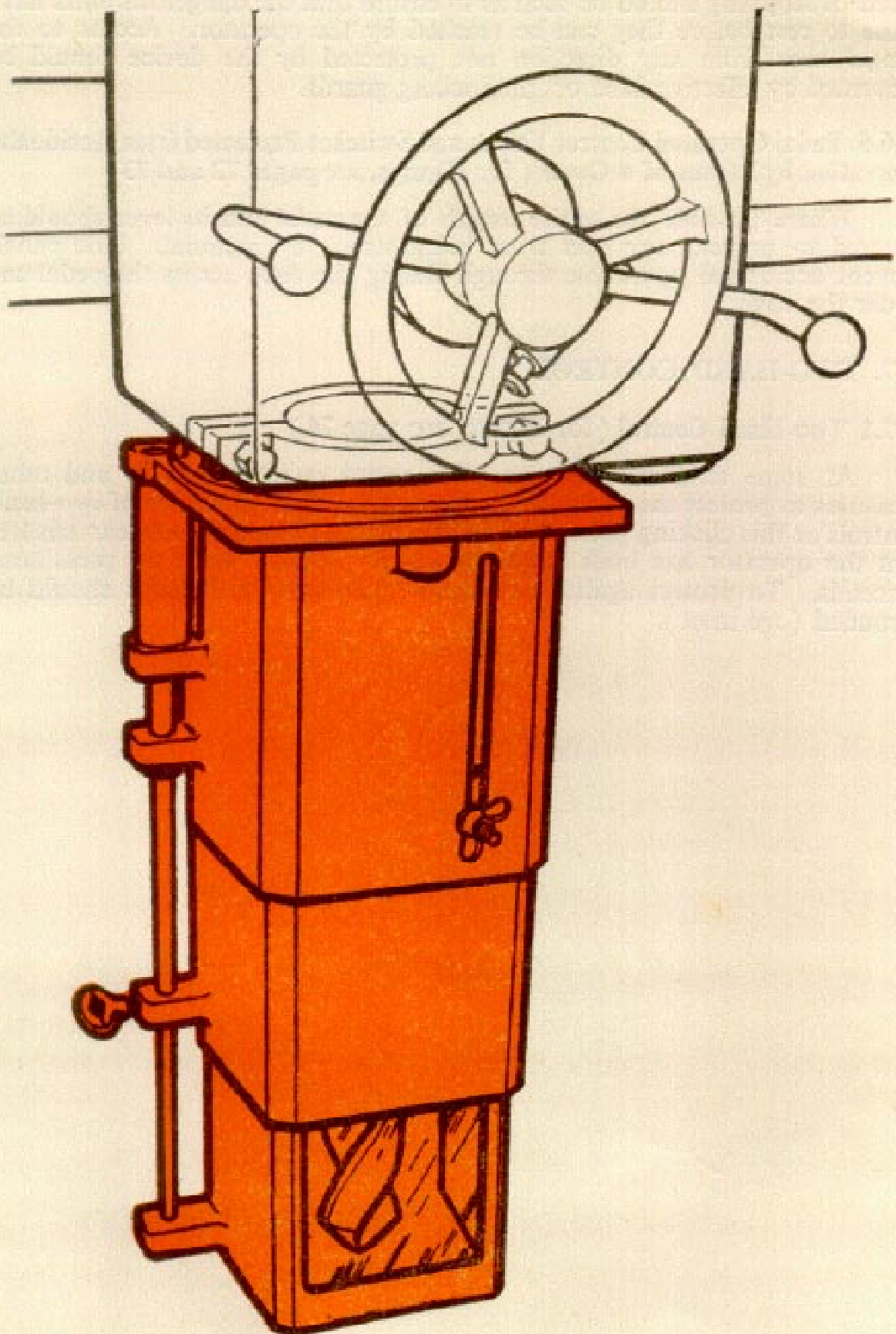

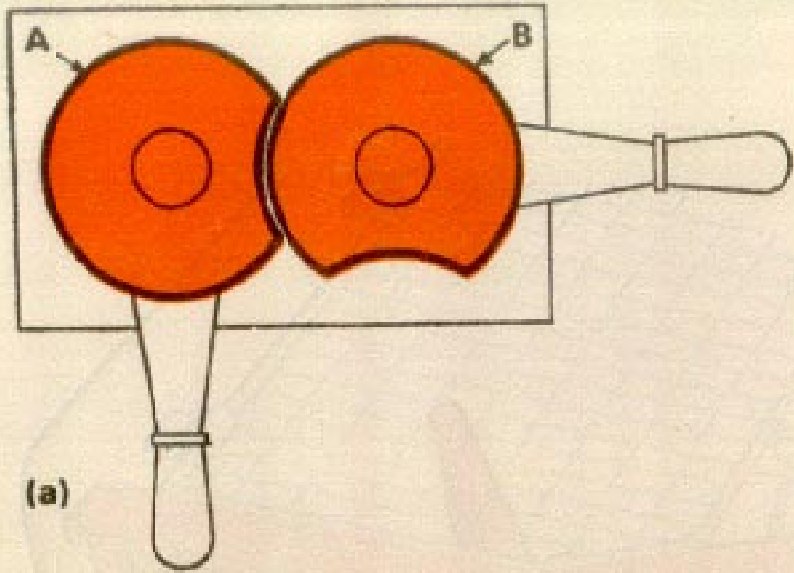

(a)

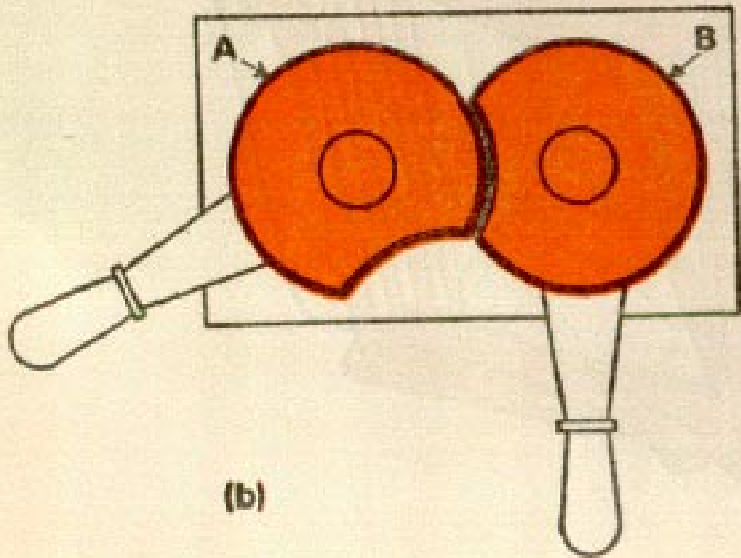

(b)

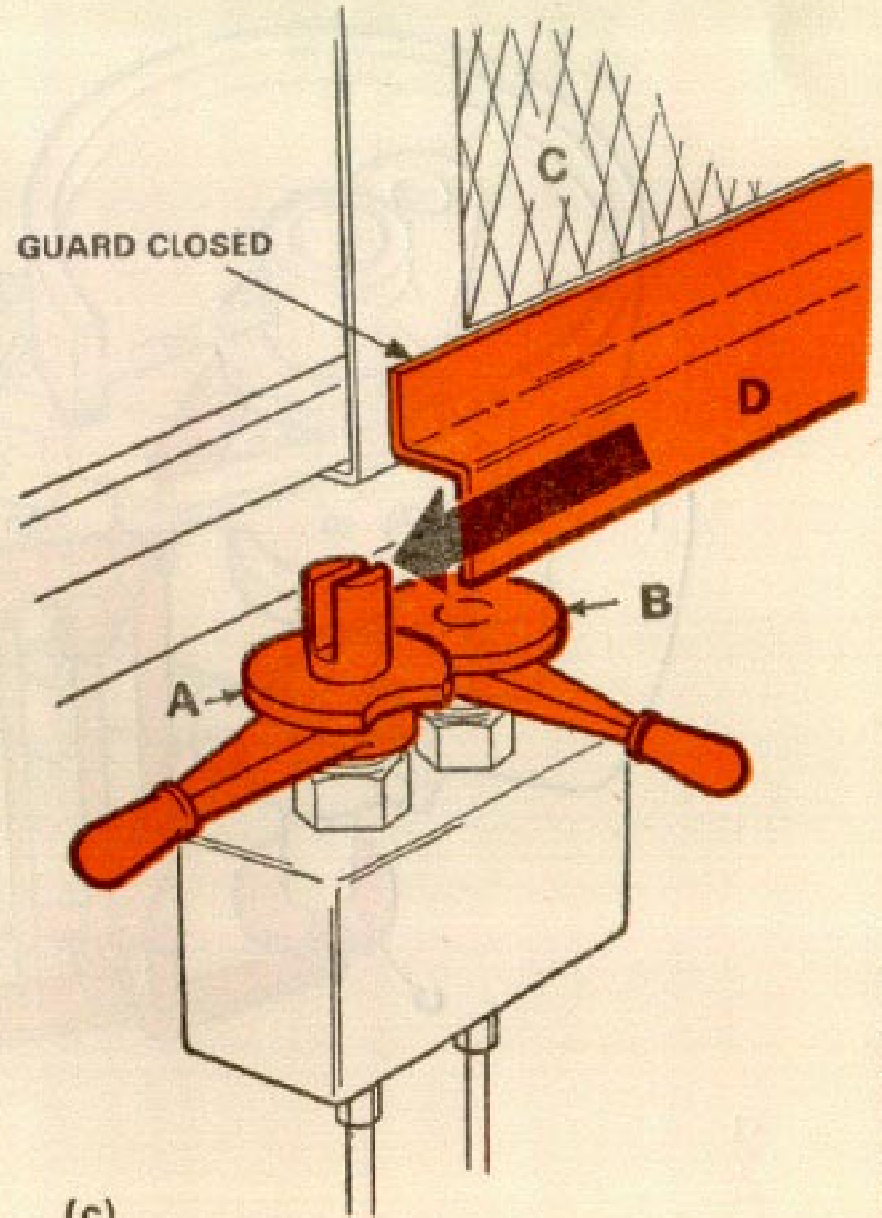

(c)

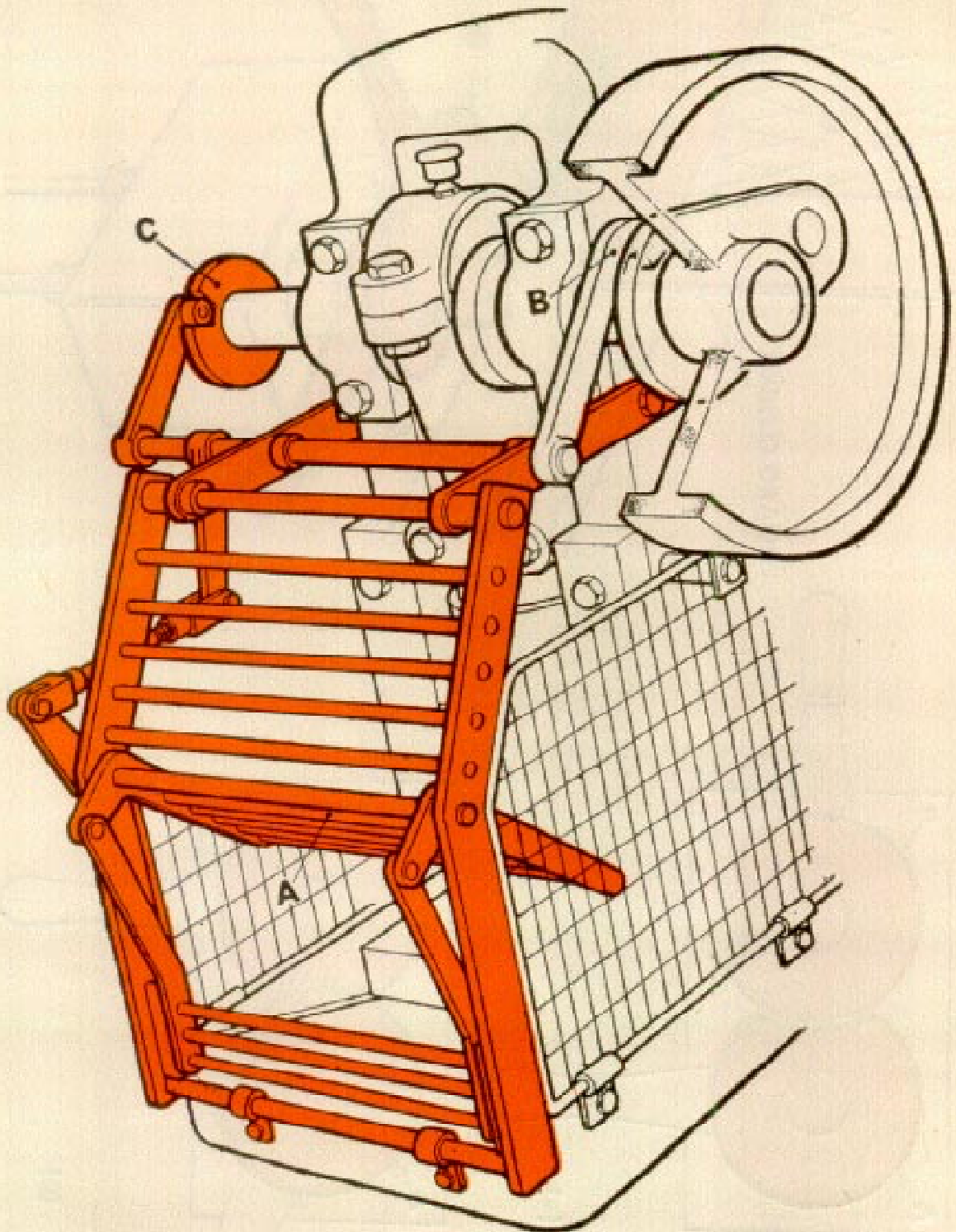

D-3.3

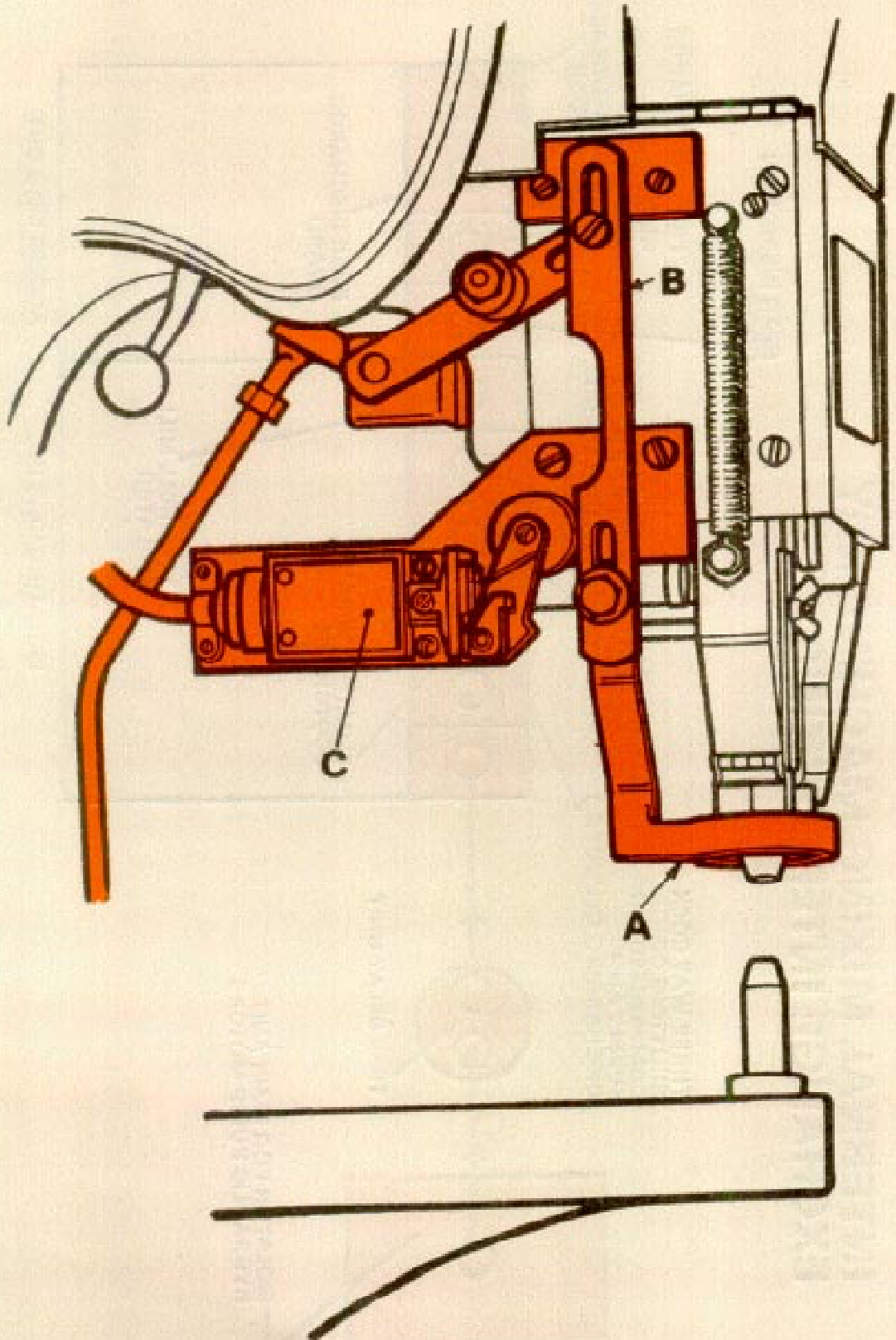

INTERNAL MIXING MACHINE KEY EXCHANGE INTERLOCKING

62

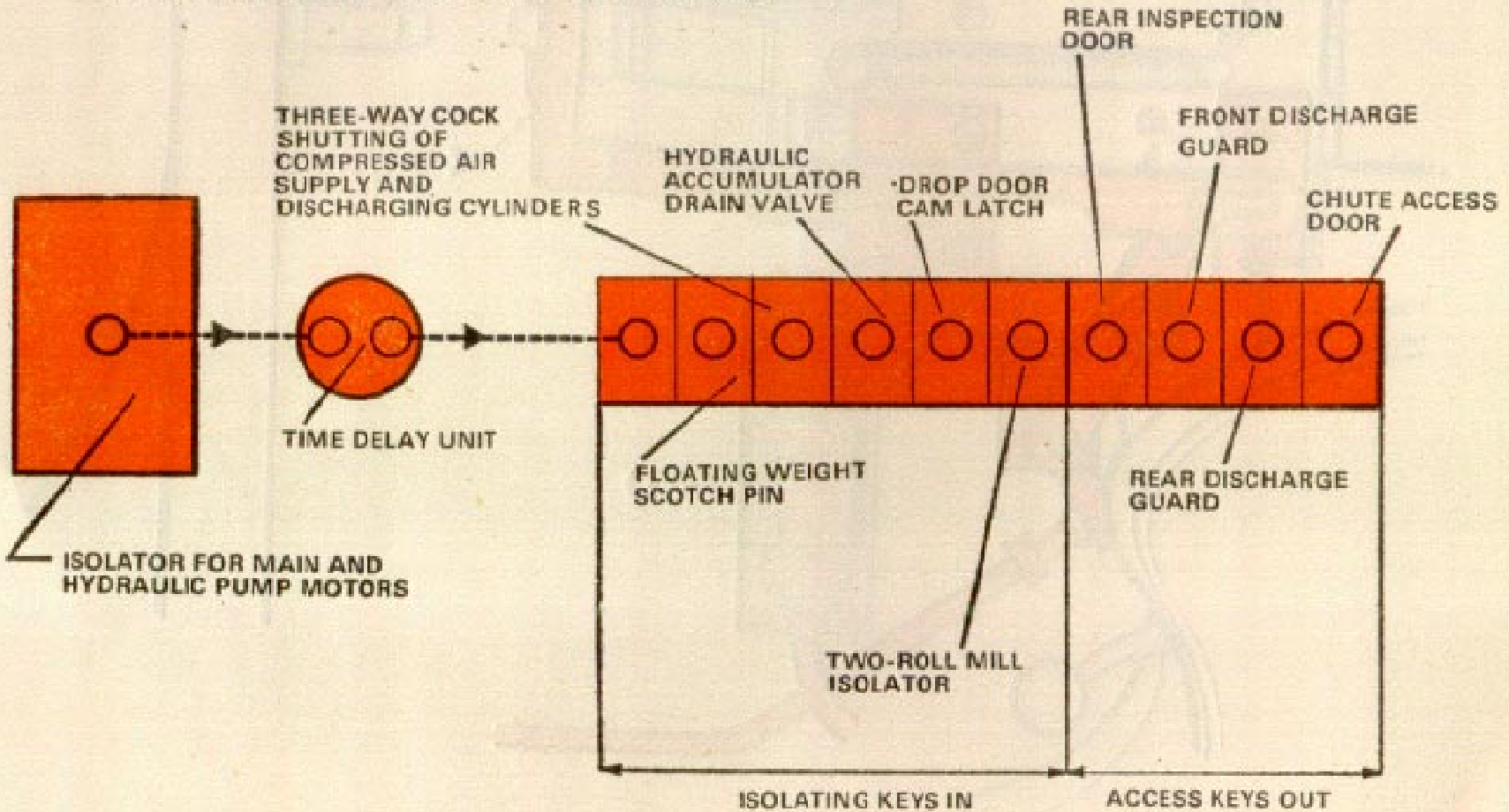

(a)

D-3.4

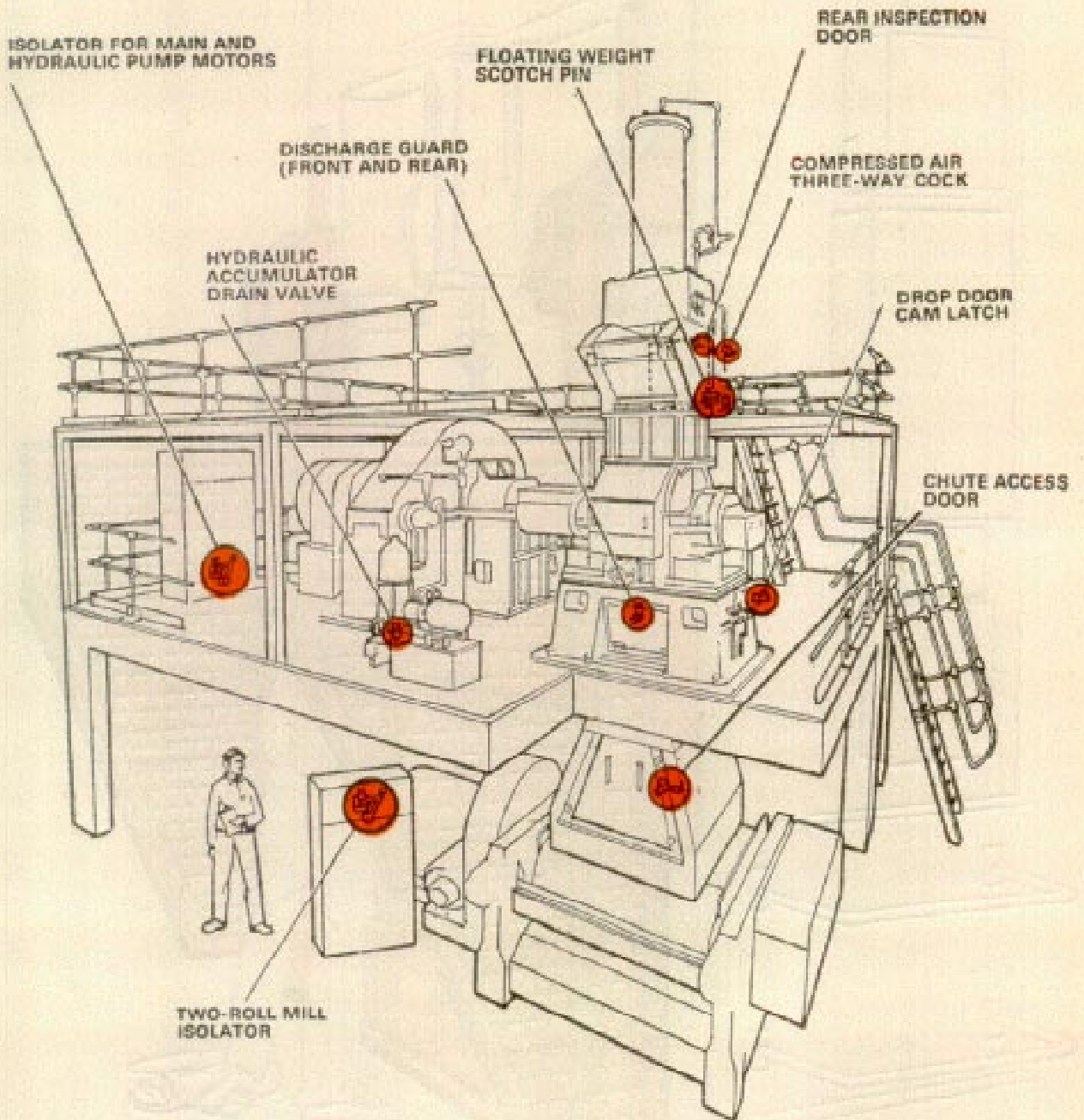

(b)

D-4.1

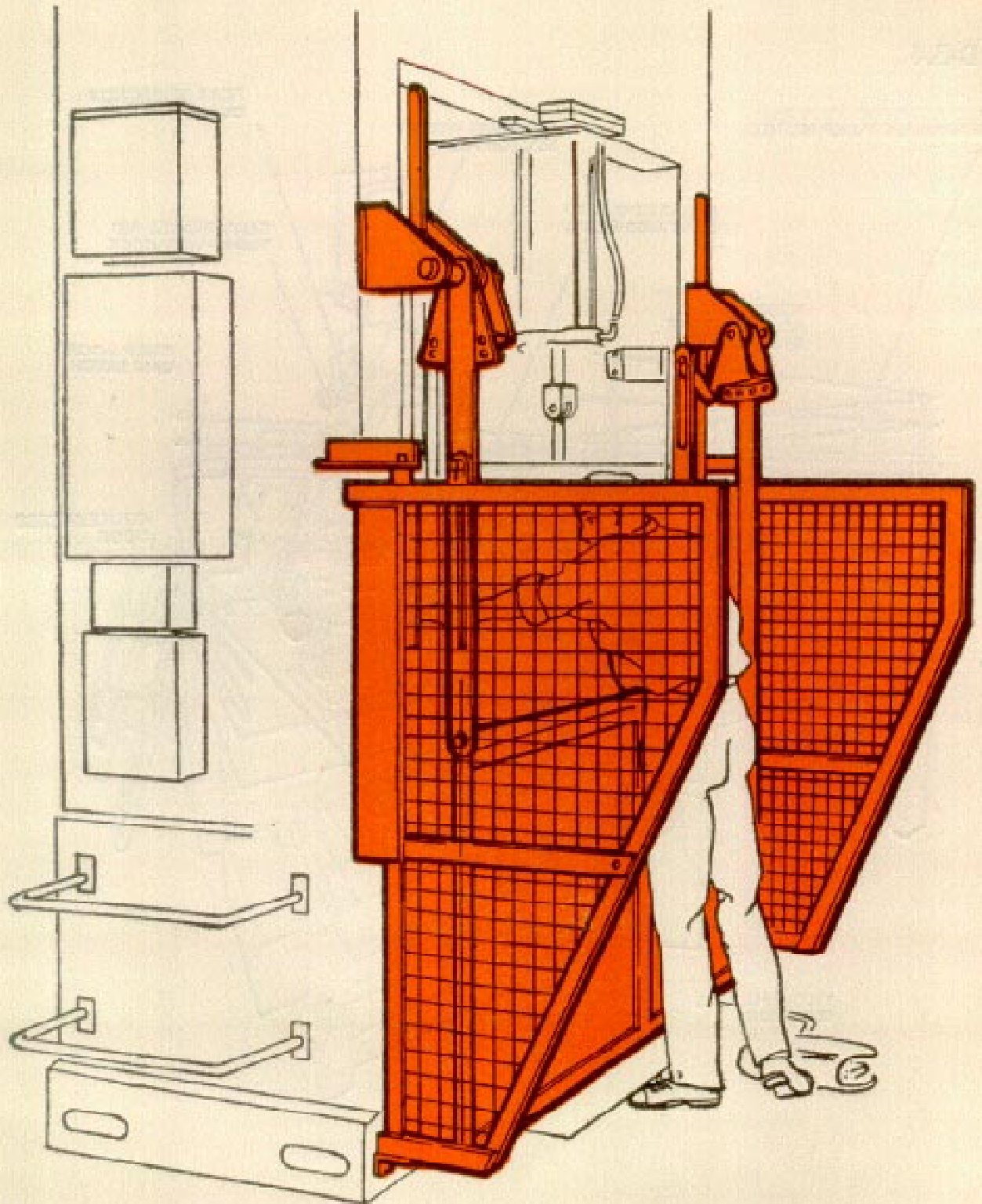

(a)

D-4.1

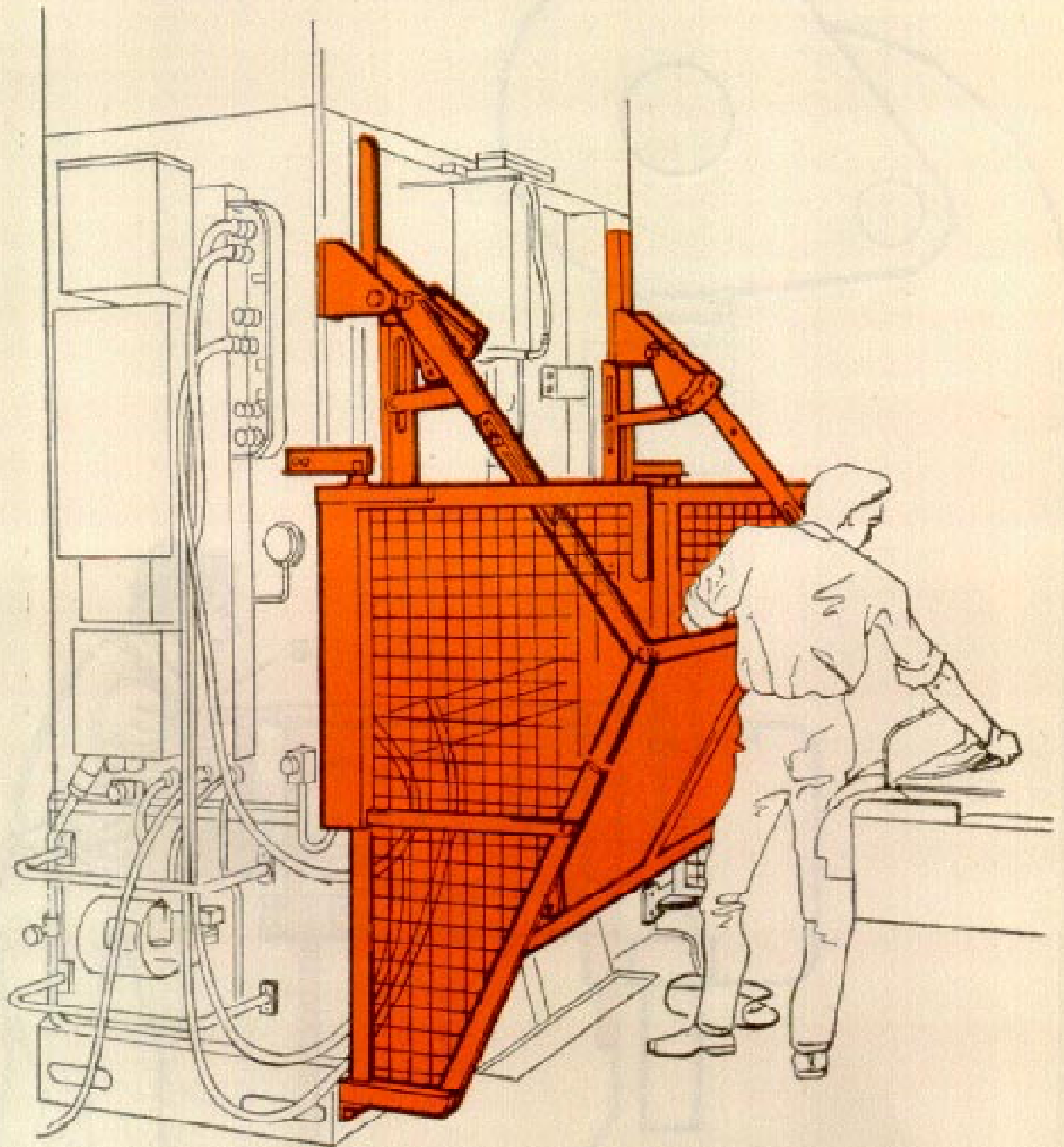

(b)

D-5.1

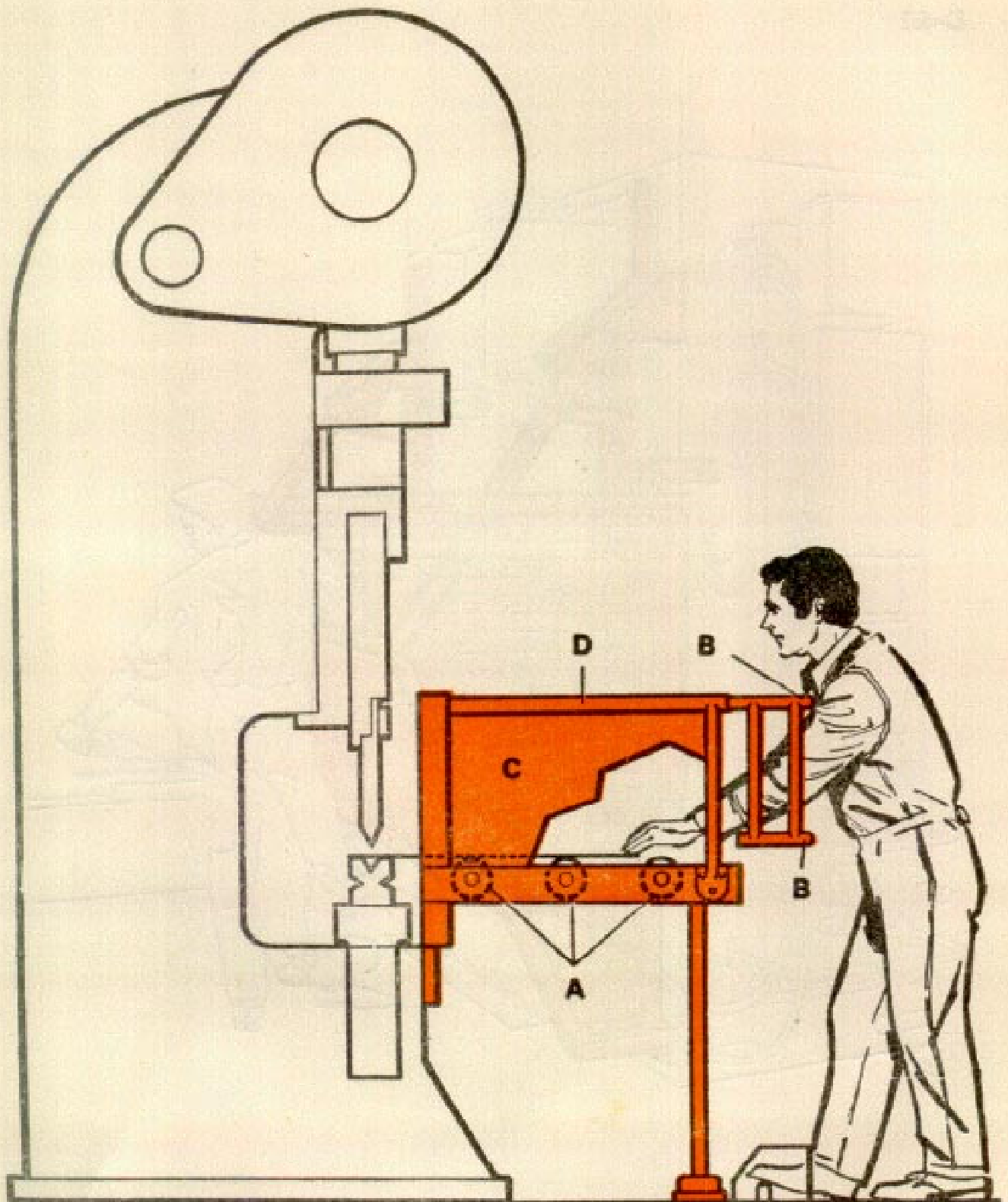

D-6.1

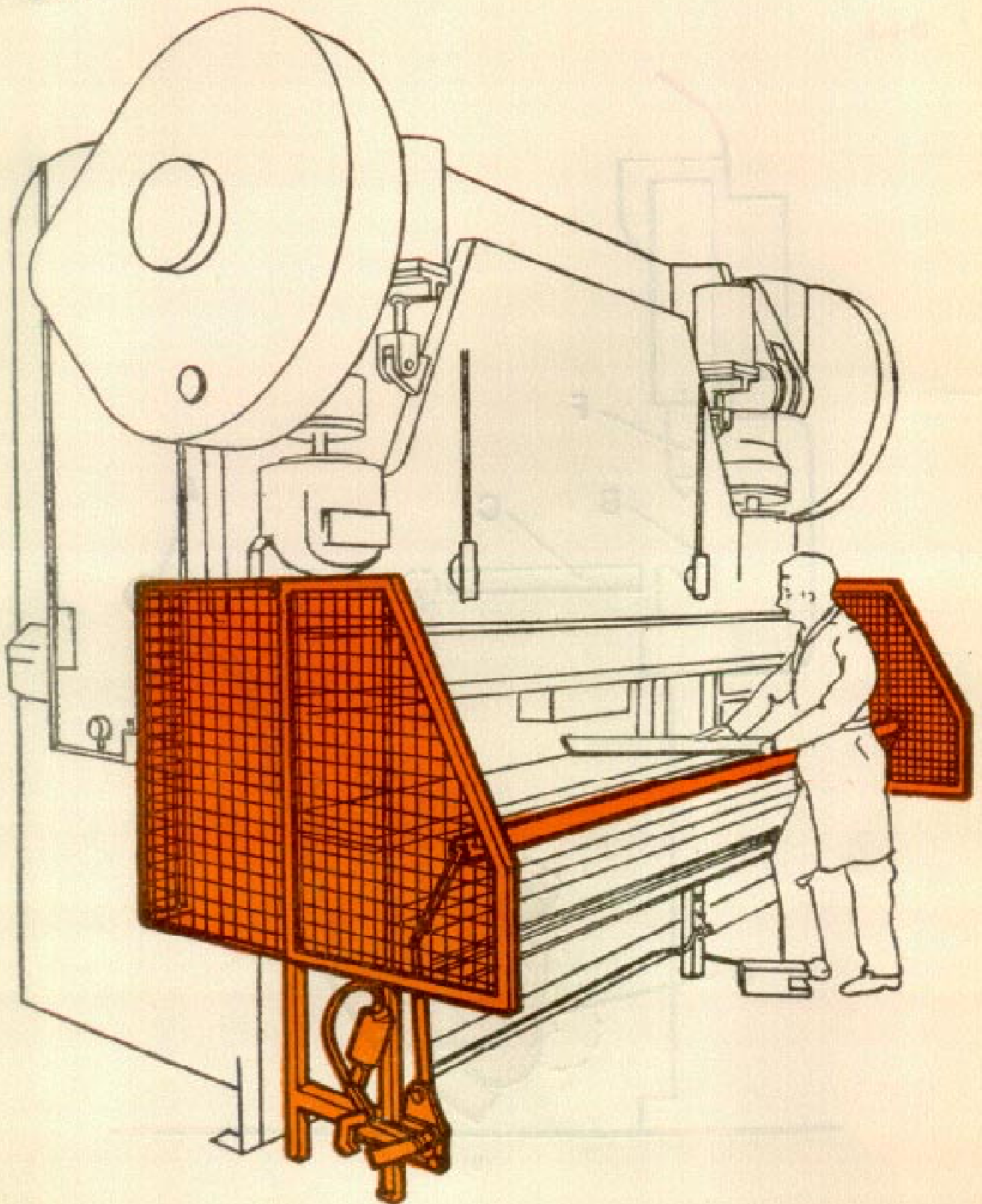

(A)

D-6.1

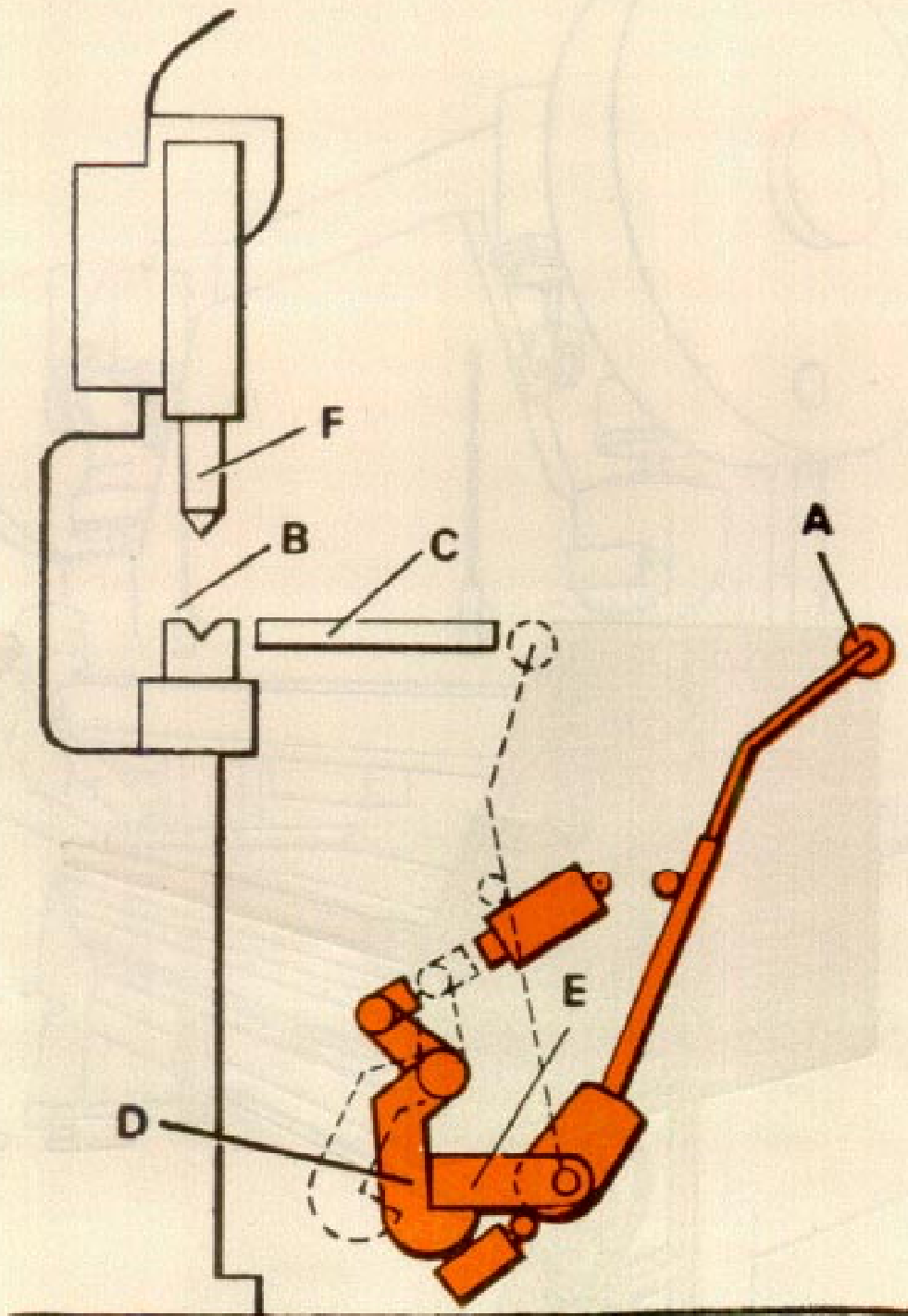

(B)

D-6.2

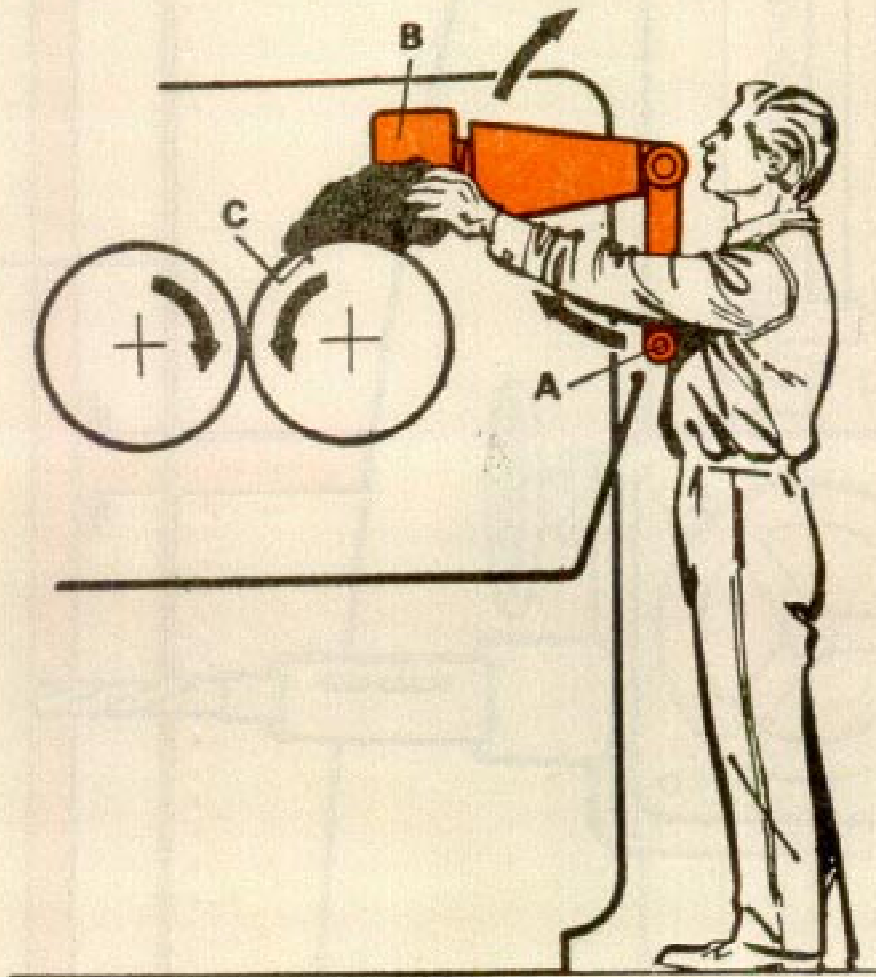

70

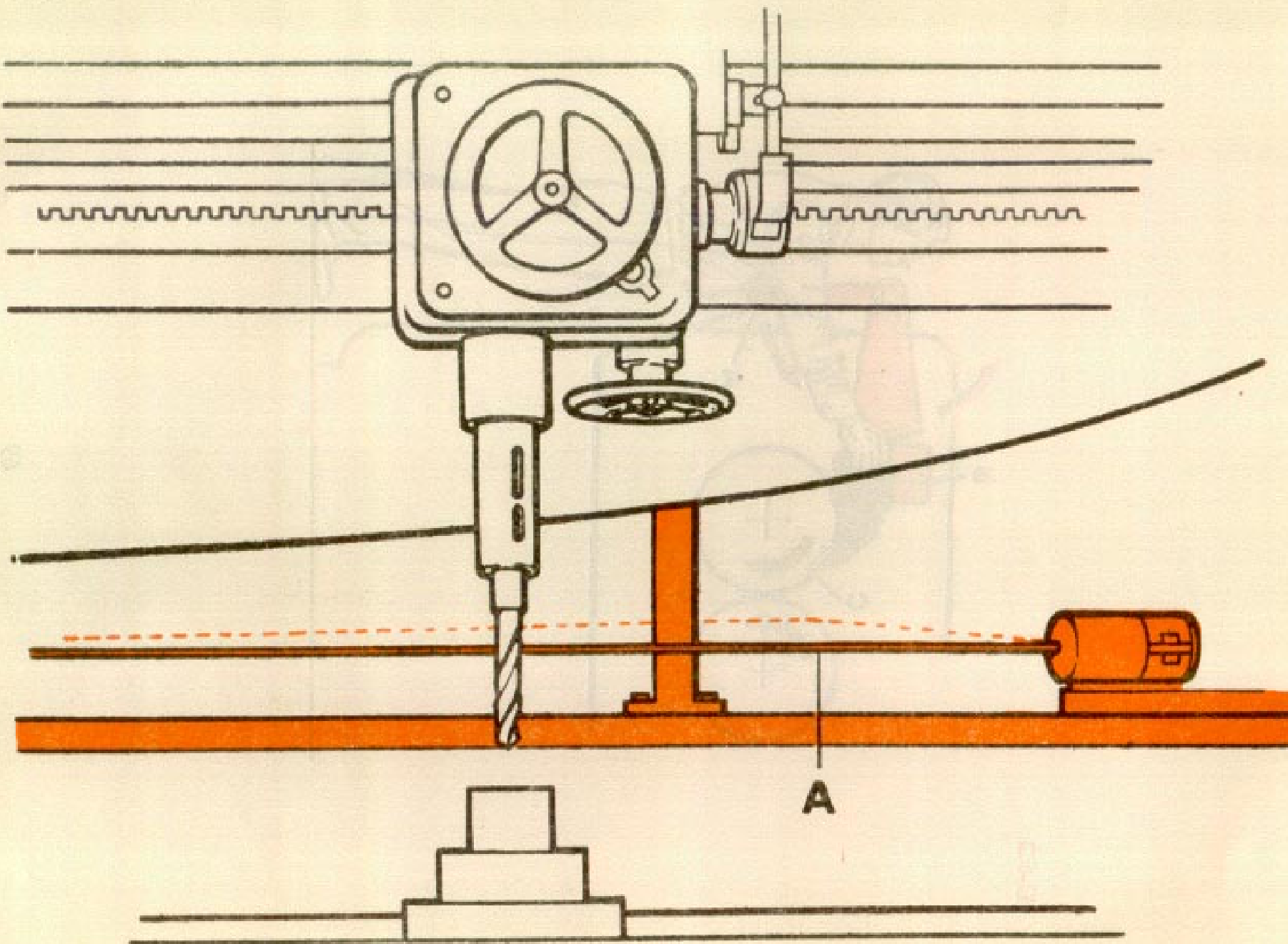

D-6.4

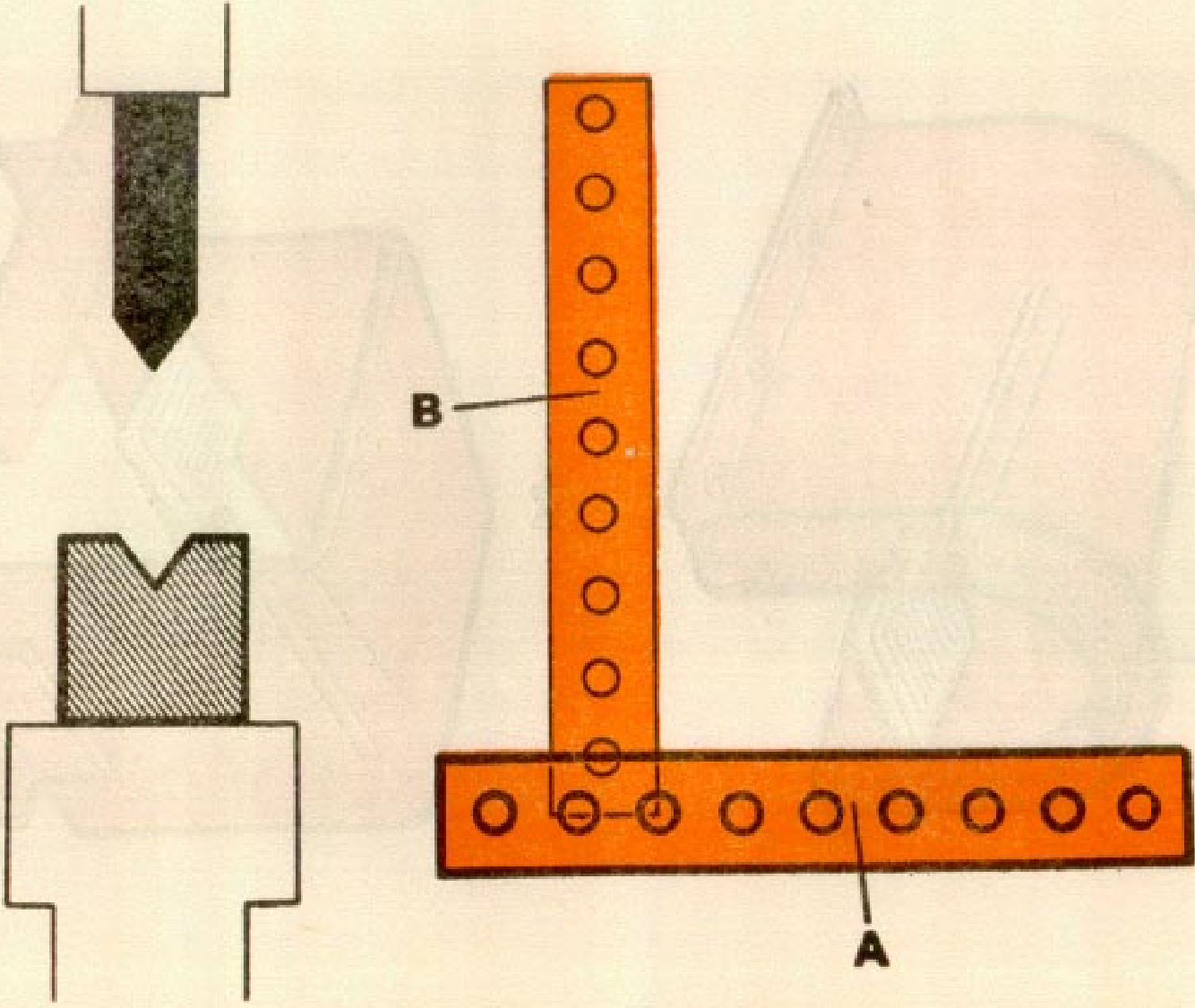

71

RUBBUR TUBE

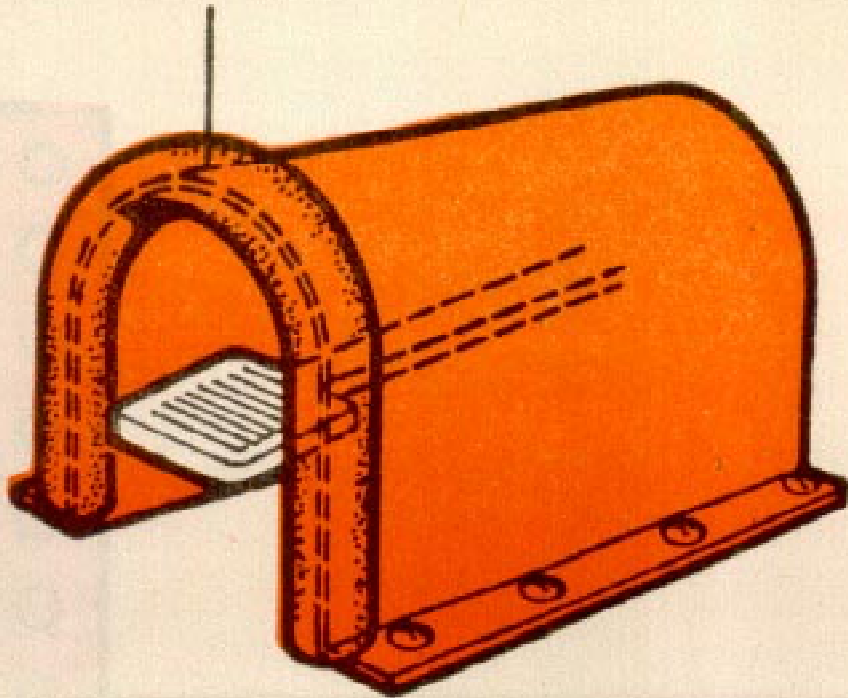

(A)

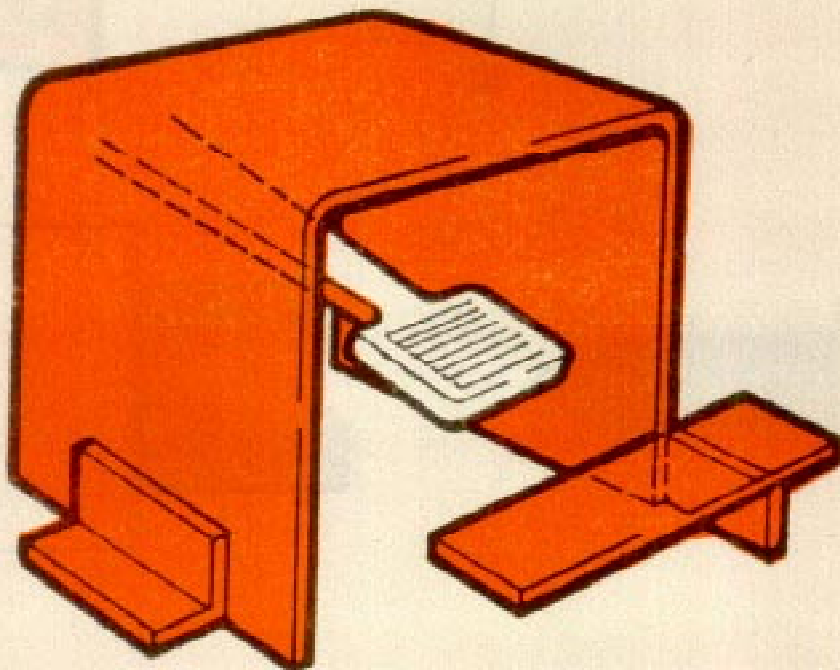

(B)

D-6.5

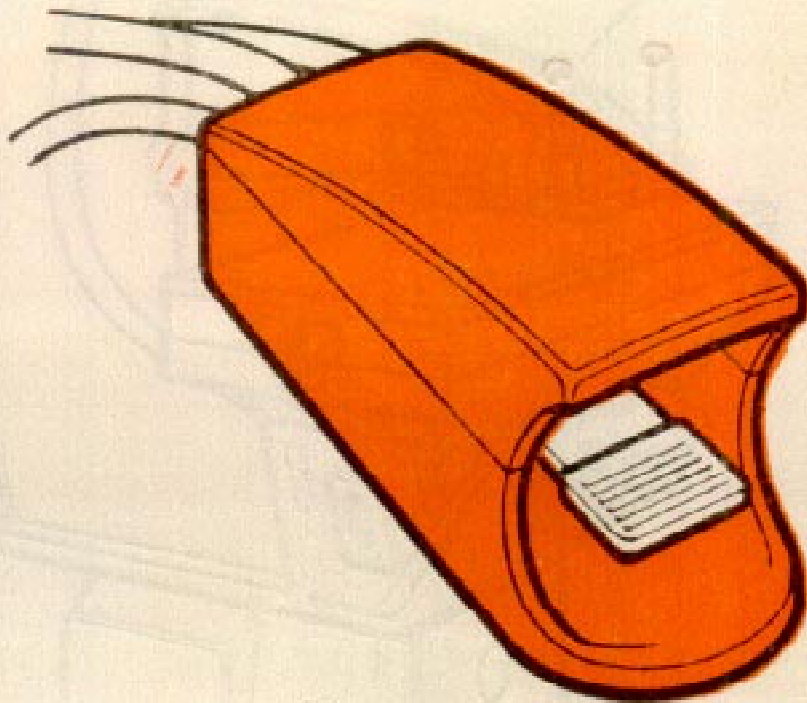

(C)

IS : 9474 - 1980

D-7.1

