

इंटरनेट

मानक

Disclosure to Promote the Right To Information

Whereas the Parliament of India has set out to provide a practical regime of right to information for citizens to secure access to information under the control of public authorities, in order to promote transparency and accountability in the working of every public authority, and whereas the attached publication of the Bureau of Indian Standards is of particular interest to the public, particularly disadvantaged communities and those engaged in the pursuit of education and knowledge, the attached public safety standard is made available to promote the timely dissemination of this information in an accurate manner to the public.

“जानने का अधिकार, जीने का अधिकार”

Mazdoor Kisan Shakti Sangathan

“The Right to Information, The Right to Live”

“पुराने को छोड़ नये के तरफ”

Jawaharlal Nehru

“Step Out From the Old to the New”

IS 8869 (1978): Washers for Corrugated Sheet Roofing [PGD
31: Bolts, Nuts and Fasteners Accessories]

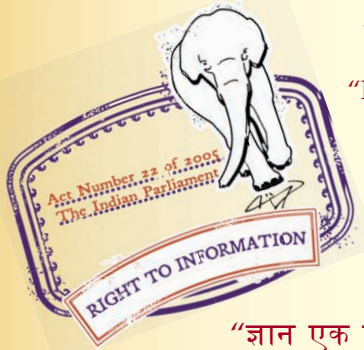

“ज्ञान से एक नये भारत का निर्माण”

Satyanarayan Gangaram Pitroda

“Invent a New India Using Knowledge”



“ज्ञान एक ऐसा खजाना है जो कभी चुराया नहीं जा सकता है”

Bhartrhari—Nitiśatakam

“Knowledge is such a treasure which cannot be stolen”

BLANK PAGE





Indian Standard

SPECIFICATION FOR WASHERS FOR CORRUGATED SHEET ROOFING

1. Scope — Covers the requirements for washers for corrugated sheet roofing.

2. Types — The following types of washers are covered:

- a) Bituminous felt washers,
- b) Steel washers, and
- c) Lead washers.

3. Dimensions — Dimensions of washers for corrugated sheet roofing shall be as given in Tables 1, 2 and 3.

TABLE 1 DIMENSIONS FOR BITUMINOUS FELT WASHERS

All dimensions in millimetres.

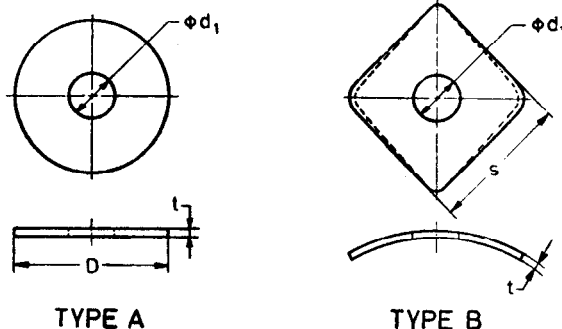

Nominal Size, d_1	t	D	s	Suitable Bolt Size
7	1.6	25	36	M6
10	1.6	30	36	M8
12	1.6	30	36	M10

4. Grade — Washers shall conform to ordinary grade as specified in IS : 5369-1975 'General requirements for plain washers and lock washers (*first revision*)'.

5. Material

5.1 Steel washers shall be made from any suitable low carbon steel.

5.2 Lead washers shall be made from lead sheets as specified in IS : 405-1961 'Specification for lead sheet (*revised*)'.

6. Designation — Designation of washers shall be as given in Table 4.

7. Sampling — The method of sampling and acceptance criteria shall be in accordance with IS : 6821-1973 'Methods for sampling non-threaded fasteners'.

8. General Requirements

8.1 Steel washers for corrugated roofing shall be galvanized by hot dipping as specified in IS : 5358-1969 'Specification for hot-dip galvanized coatings on fasteners'.

Adopted 21 July 1978

© December 1978, ISI

Printed

TABLE 2 DIMENSIONS FOR STEEL WASHERS

(Clause 3)

All dimensions in millimetres.

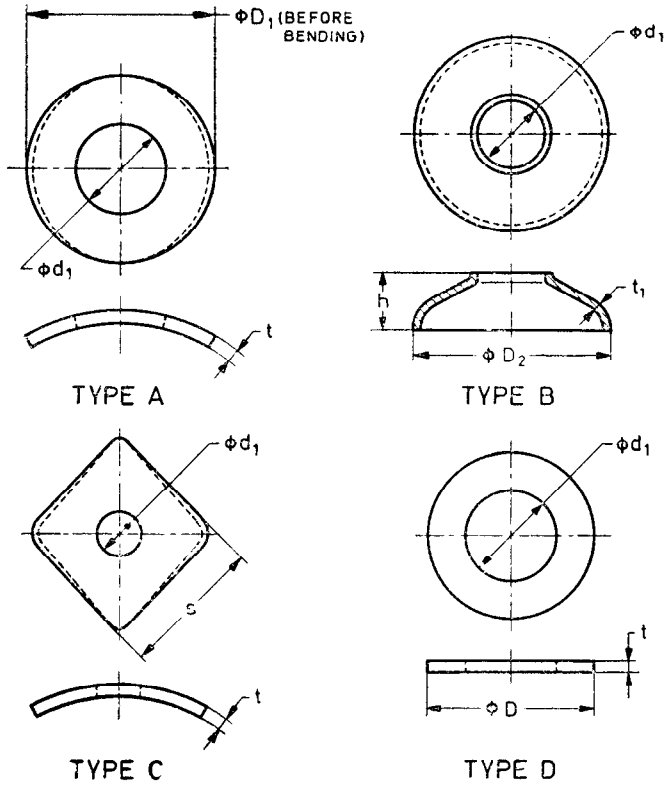

Nominal Size, d_1	t	t_1	D	D_1	D_2	h	s	Suitable Bolt Size
7	1.60	0.90	12	25	35	10	36	M6
10	1.60	0.90	16	25	35	10	36	M8
12	1.60	0.90	22	25	35	10	36	M10

TABLE 3 DIMENSIONS FOR LEAD WASHERS

(Clause 3)

All dimensions in millimetres.

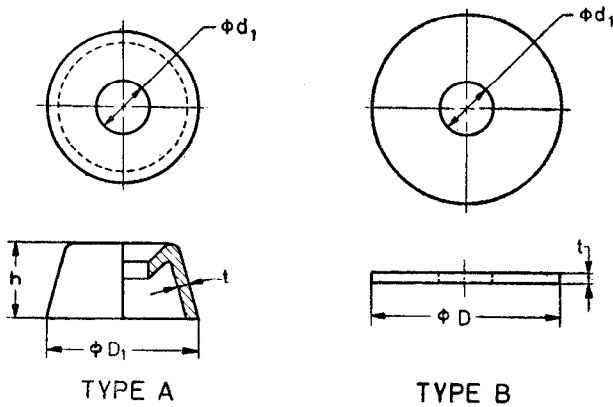

Nominal Size, d_1	t	D	D_1	h	Suitable Bolt Size
7	1.6	25	20	10	M6
10	1.6	25	25	10	M8
12	1.6	25	30	10	M10

TABLE 4 DESIGNATION SYSTEM FOR WASHERS

(Clause 6)

Name of Washer and Type	Nominal Size	Designation
Bituminous felt washer, Type A	7	Bituminous Felt Washer A7 — IS : 8869
Steel washer, Type D	10	Steel Washer D10 — IS : 8869
Lead washer, Type B	12	Lead Washer B12 — IS : 8869

8.2 Bituminous felt washers shall be suitably impregnated. These washers when heated and maintained at a temperature of $75 \pm 1^\circ\text{C}$ for 1 hour shall not get separated and flow out.

9. **ISI Certification Marking** — Details available with the Indian Standards Institution.

EXPLANATORY NOTE

Subsequent to the decision to revise IS : 730-1966 ' Specification for fasteners for corrugated sheet roofing (revised) ' splitting into three standards, this standard has been prepared on washers. Requirements of hook bolts and mushroom head bolts are being covered in separate Indian Standards.

In this standard washers suitable for bolt size M5 have not been covered.

This standard has been brought in line with BS 1494 : Part I : 1964 ' Fixing accessories for building purposes ' issued by British Standards Institution.