

इंटरनेट

मानक

Disclosure to Promote the Right To Information

Whereas the Parliament of India has set out to provide a practical regime of right to information for citizens to secure access to information under the control of public authorities, in order to promote transparency and accountability in the working of every public authority, and whereas the attached publication of the Bureau of Indian Standards is of particular interest to the public, particularly disadvantaged communities and those engaged in the pursuit of education and knowledge, the attached public safety standard is made available to promote the timely dissemination of this information in an accurate manner to the public.

“जानने का अधिकार, जीने का अधिकार”

Mazdoor Kisan Shakti Sangathan

“The Right to Information, The Right to Live”

“पुराने को छोड़ नये के तरफ”

Jawaharlal Nehru

“Step Out From the Old to the New”

IS 8033 (1976): Round Washers with Square Hole for Wood Fastenings [PGD 31: Bolts, Nuts and Fasteners Accessories]



“ज्ञान से एक नये भारत का निर्माण”

Satyanarayan Gangaram Pitroda

“Invent a New India Using Knowledge”



“ज्ञान एक ऐसा खजाना है जो कभी चुराया नहीं जा सकता है”

Bhartrhari—Nitiśatakam

“Knowledge is such a treasure which cannot be stolen”

BLANK PAGE



AMENDMENT NO. 1 JANUARY 1979

TO

IS:8033-1976 SPECIFICATION FOR ROUND WASHERS
WITH SQUARE HOLE FOR WOOD FASTENINGS

Alteration

(Page 1, Table 1, values under column 's') -
Substitute the following for the existing values:

<u>s</u>
1
2
2
3.15
4
4
4

(EDC 27)

Reprography Unit, ISI, New Delhi



Indian Standard

SPECIFICATION FOR ROUND WASHERS WITH SQUARE HOLE FOR WOOD FASTENINGS

1. **Scope** — Covers the requirements for washers with square hole for use in wood fastenings with bolts in the diameter range 6 to 24 mm.
2. **Grade** — Shall conform to ordinary grade of IS : 5369-1975 'General requirements for plain washers and lock washers (first revision)'.¹
3. **Dimensions** — As given in Table 1.

TABLE 1 DIMENSIONS OF WASHERS WITH SQUARE HOLE

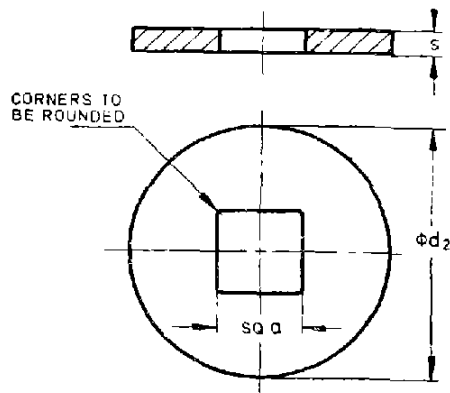

All dimensions in millimetres.

Size a	d_2	s	Suitable for Bolt Size
6	22	2	M 6
9	28	3.15	M 8
11	34	3.15	M10
14	45	4	M12
18	58	5	M16
22	68	5	M20
26	92	6	M24

3.1 Dimensional tolerances as well as tolerance for form and position shall conform to those of ordinary washers of IS : 5369-1975.

4. **Material** — Washers with square hole for wood fastenings shall be made from any low carbon steel or any other material specified by the purchaser.

5. **Designation** — A round washer with square hole shall be designated by the name, nominal size and the number of this standard.

Adapted 30 April 1976

© July 1976, ISI

INDIAN STANDARDS INSTITUTION
MANAK BHAVAN, 9 BAHADUR SHAH ZAFAR MARG
NEW DELHI 110002

IS : 8033 - 1976

Example:

A round washer with square hole of nominal size 14 mm shall be designated as:

Washer With Square Hole 14 IS : 8033

6. General Requirements — In regard to the requirements not covered in this standard, they shall conform to the requirements of IS : 5369-1975.

7. ISI Certification Marking — Details available with the Indian Standards Institution.

EXPLANATORY NOTE

Round washers with square hole for wood fastenings are intended for use with coach bolts conforming to IS : 2609-1972 'Coach bolts (M6 to M24) (*first revision*)'. In the preparation of this standard considerable assistance has been derived from DIN 440 'Schieben vorwiegend für Holzkonstruktionen (Round washers for wood constructions), 1974 ' issued by DIN Deutsches Institut für Normung.



AMENDMENT NO. 2 AUGUST 1984

TO

IS : 8033 -1976 SPECIFICATION FOR ROUND WASHERS
WITH SQUARE HOLE FOR WOOD FASTENINGS

Alterations

(Page 1, title) — Substitute the following for the existing title.

' Indian Standard

SPECIFICATION FOR
WASHERS WITH SQUARE HOLE
FOR WOOD FASTENINGS '

(Page 1, Table 1, second column, heading) — Substitute ' d_s or b ' for ' d_s '.

Addendum

(Page 1, Table 1) — Add the following new figure:

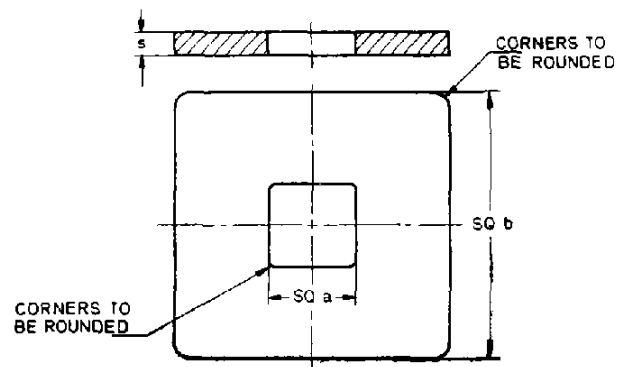

(EDC 27)