

इंटरनेट

मानक

Disclosure to Promote the Right To Information

Whereas the Parliament of India has set out to provide a practical regime of right to information for citizens to secure access to information under the control of public authorities, in order to promote transparency and accountability in the working of every public authority, and whereas the attached publication of the Bureau of Indian Standards is of particular interest to the public, particularly disadvantaged communities and those engaged in the pursuit of education and knowledge, the attached public safety standard is made available to promote the timely dissemination of this information in an accurate manner to the public.

“जानने का अधिकार, जीने का अधिकार”

Mazdoor Kisan Shakti Sangathan

“The Right to Information, The Right to Live”

“पुराने को छोड़ नये के तरफ”

Jawaharlal Nehru

“Step Out From the Old to the New”

IS 6293 (1996): Assembly tools for screws and nuts -
Nomenclature [PGD 5: Assembly Hand Tools]



“ज्ञान से एक नये भारत का निर्माण”

Satyanarayan Gangaram Pitroda

“Invent a New India Using Knowledge”



“ज्ञान एक ऐसा खजाना है जो कभी चुराया नहीं जा सकता है”

Bhartrhari—Nitiśatakam

“Knowledge is such a treasure which cannot be stolen”

BLANK PAGE



भारतीय मानक
पैचों और नटों के लिए समुच्चय औज़ार — नामावली
(दूसरा पुनरीक्षण)

Indian Standard
ASSEMBLY TOOLS FOR SCREWS AND NUTS —
NOMENCLATURE
(*Second Revision*)

ICS 01.040.21; 25.140.30

© BIS 1996

BUREAU OF INDIAN STANDARDS
MANAK BHAVAN, 9 BAHADUR SHAH ZAFAR MARG
NEW DELHI 110002

FOREWORD

This Indian Standard (Second Revision) was adopted by the Bureau of Indian Standards, after the draft finalized by the Assembly Hand Tools Sectional Committee had been approved by the Production Engineering Division Council.

This standard was first published in 1971. The first revision was taken up in 1981 based on ISO 1703 : 1975 'Assembly tools for screws and nuts, nomenclature'.

In this revision the Indian Standards available on the various tools indicated in the last column of the tables have been updated so as to give up-to-date information to the users of the standard. The ISO Standards available on the various tools have also been indicated in the last column.

While preparing this standard considerable assistance has been derived from ISO 1703 : 1983 'Assembly tools for screw and nuts, nomenclature', issued by International Organization for Standardization (ISO).

Wherever only one nomenclature has been given, the term is the same for both Indian Standard and ISO Standard and where two nomenclatures have been given, the first one is according to Indian Standard on the subject and latter one (given in brackets) is according to ISO.

Indian Standard

ASSEMBLY TOOLS FOR SCREWS AND NUTS — NOMENCLATURE

(*Second Revision*)

1 SCOPE

This standard gives nomenclature of assembly tools for screws and nuts.





2 HAND OPERATED TOOLS FOR SCREWS AND NUTS





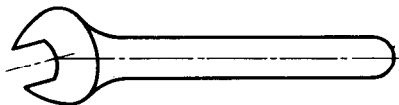
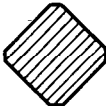
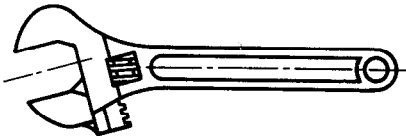
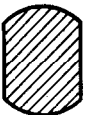
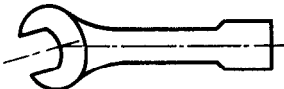
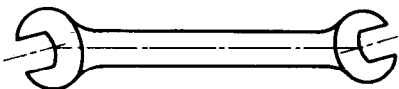
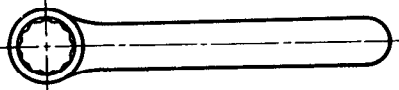

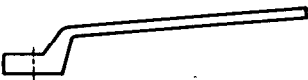
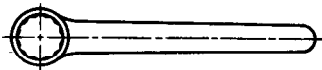

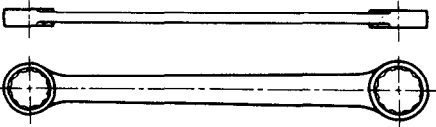
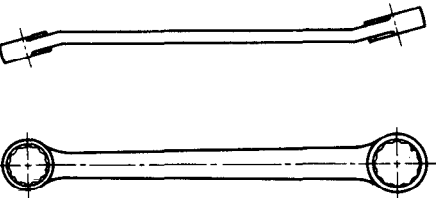

2.1 Spanners and Wrenches





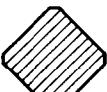

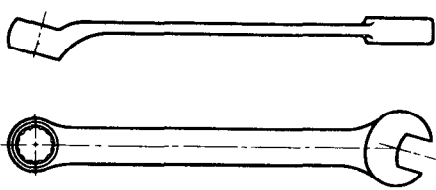

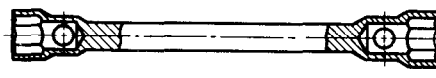
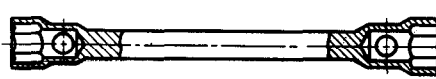
2.1.1 Definition

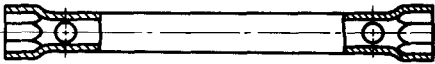

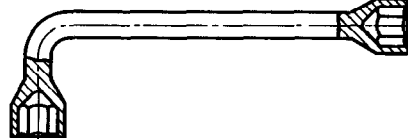

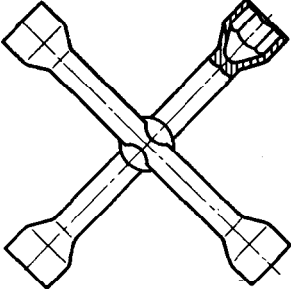

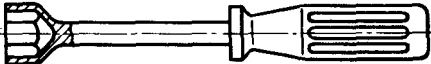

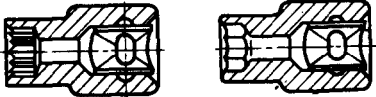
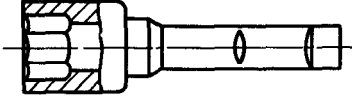

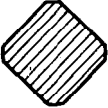
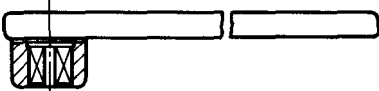

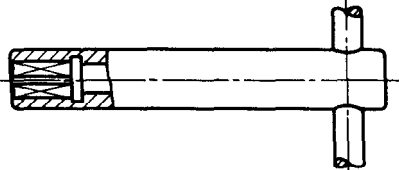

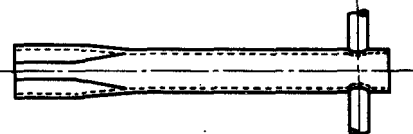
Spanners and wrenches are tools designed for operating screwed fasteners by applying a turning force either externally or internally according to type of fastener.

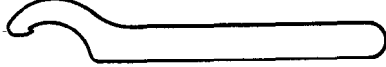
2.1.2. Nomenclature

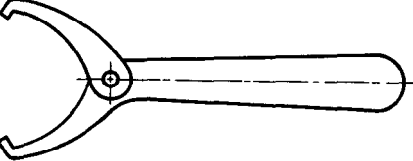
No.	Application	Tool	Nomenclature	Indian Standard and ISO Standard
1			a) Single ended open jaw spanners	IS 2028
			b) (Engineers wrench, single head)	ISO 1085
2			a) Single ended open jaw adjustable wrench (spanner)	IS 6149
			b) (Adjustable wrench, open end)	ISO 6782
3			a) Open ended slugging wrenches (spanners)	IS 4508
			b) (Slugging wrench, open end)	
4			a) Double ended open jaw spanners	IS 2028
			b) (Engineers wrench, double head, open end)	ISO 1085
5			a) Single ended ring spanner	IS 6379
			b) [Box (ring) wrench, single end]	
6			a) Cranked single ended ring spanner	—
			b) [Box (ring) wrench, single end deep offset]	ISO 1085
7			a) Ring slugging wrenches (spanners)	IS 4509
			b) [Slugging wrench, box (ring)]	

No.	Application	Tool	Nomenclature	Indian Standard and ISO Standard
8			a) Straight double ended ring spanners b) [Box (ring) wrench, double head, flat]	IS 2029 ISO 10103
9			a) Angled double ended ring spanner b) [Box (ring) wrench, double head, 15° offset]	IS 2029 ISO 10103
10			a) Cranked double ended ring spanner b) [Box (ring) wrench, double end, deep offset]	IS 2029 ISO 10104
11			a) Double ended offset ring spanner b) [Box (ring) wrench, double end, modified offset]	IS 2029 ISO 10104
12			Flare nut wrench, double end, flat	IS 7939
13	 		Combination wrench	IS 6389
14			Combination wrench, deep offset	IS 6389 ISO 7738
15			a) Single ended solid box spanner b) (Tee wrench, socket, single end)	IS 2030 ISO 2236
16			a) Single ended tubular box spanner b) (Tee wrench, socket, tubular single end)	IS 2030 ISO 2236
17			a) Double ended solid box spanner b) (Tee wrench, socket, double end)	IS 2030 ISO 2236

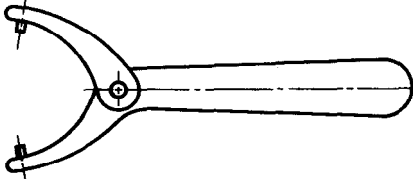
No.	Application	Tool	Nomenclature	Indian Standard and ISO Standard
18			a) Double ended tubular box spanner b) (Tee wrench, socket, tubular double end)	IS 2030 ISO 2236
19			Socket wrench, single end, 90° offset	IS 11874
20			Socket wrench, double end, 90° offset one end	IS 11874
21			a) Cross rim wrenches b) (Socket wrench, four way)	IS 12521 ISO 6788
22			Socket wrench, double end, flex head	
23			Socket Wrench, spin type	IS 8670
24			Socket wrench, square drive, double hex	—
25			Socket shank for use with spiral ratchet screwdriver	—

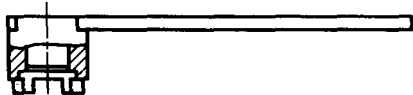
No.	Application	Tool	Nomenclature	Indian Standard and ISO Standard
26			a) Square box wrench (spanner) b) (Tee wrench, socket single square)	IS 6129 ISO 1085
27			a) Square tee wrench (spanner) b) (Tee wrench, socket single square)	IS 6130 ISO 2236
28			Tee wrench, triangular	
29			Hook wrench	IS 9063
30			Adjustable hook wrench	IS 9063
31			Pin wrench	IS 9063
32			Adjustable pin wrench	IS 9063
33			a) Wrenches for retaining screw for milling arbors b) (Wrench male cruciform)	IS 11379





2.2 Screw driver





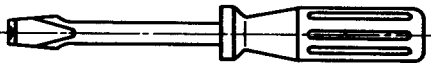
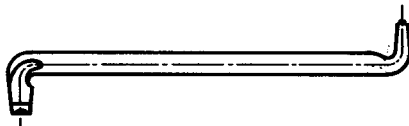
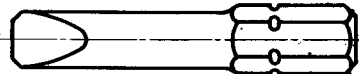
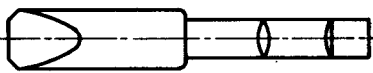
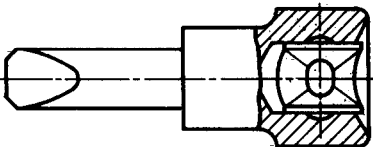

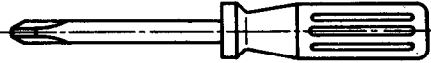
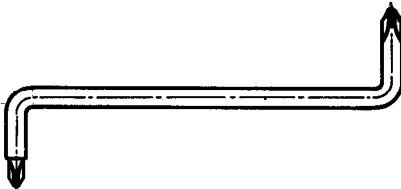

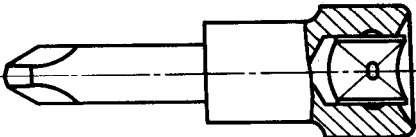

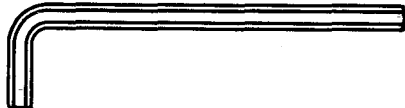

2.2.1 Definition

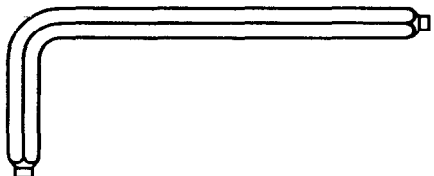
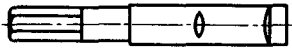

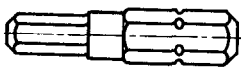
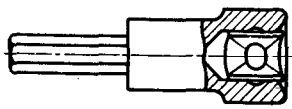

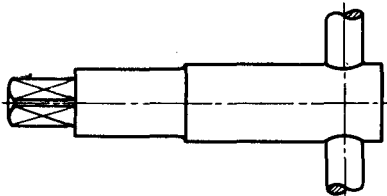
Screwdrivers are tools intended for turning screwed

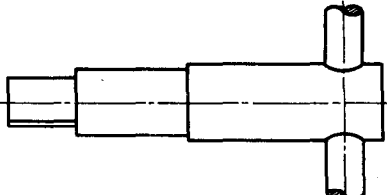

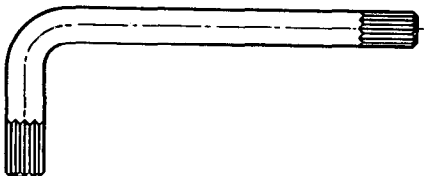
fasteners. They operate by fitting into a slot or recess in the head of the fastener which passes through its center of rotation.

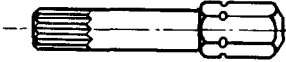
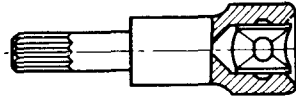
2.2.2 Nomenclature

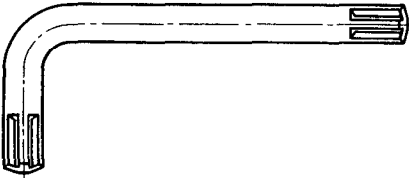
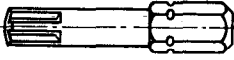
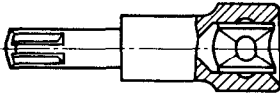
No.	Application	Tool	Nomenclature	Indian Standard and ISO Standard
101			Screwdriver for slotted head screws	IS 844 ISO 2380-2
102			Screwdriver for slotted head screws, double offset	IS 844 ISO 2380-2
103			Screwdriver bit for slotted head screws, hexagon shank	— ISO 2351
104			Screwdriver bit for slotted head screws, ratchet drivers	IS 12168 ISO 2351
105			Screwdriver for Slotted head screws, square drive	— —
106			Screwdriver for recessed head screws	IS 844 ISO 8764-2
107			Screwdriver for recessed head screws, double offset	IS 844 ISO 8764-2
108			Screwdriver bit, for recessed head screws, hexagn shank	— —
109			Screwdriver bit, for recessed head screws, ratchet drivers	IS 12168
110			Screwdriver for recessed head screws, square drive	—

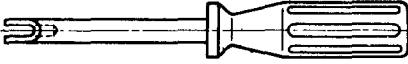
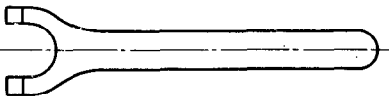
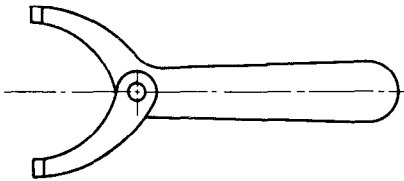
No.	Application	Tool	Nomenclature	Indian Standard and ISO Standard
111			Key with handle for hexagon socket screws	—
112			a) Hexagon keys for socket head screws b) (Key, hexagon socket screws)	IS 3082 ISO 2936
113			Key, hexagon socket screws, with pilot	—
114			Key, hexagon socket screws for spiral ratchet	—
115			Bit, hexagon socket screws hexagon shank	—
116			Bit, hexagon socket screws, square drive	—
117			Tee wrench, male square	IS 6130
118			Tee wrench, male triangular	—
119			Screwdriver for screws with internal serrations	—
120			Key for screws with internal serrations	—

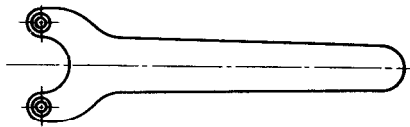
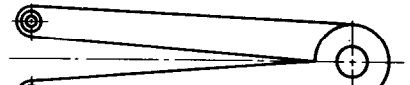
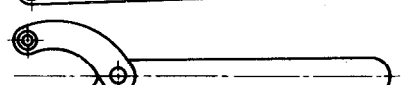
No.	Application	Tool	Nomenclature	Indian Standard and ISO Standard
121			Bit for screws with internal serrations, hexagon shank	---
122			Bit for screws with internal serrations, square drive	---
123			Bit for screws with internal serrations for ratchet drivers	---
124			Key, spline socket screws	---
125			Bit, spline, socket screws, hexagon shank	---
126			Bit, spline socket screws, square drive	---
127			Slotted screwdriver	---
128			Face wrench for slotted lock rings	---
129			Adjustable face wrench for slotted lock rings	---

No.	Application	Tool	Nomenclature	Indian Standard and ISO Standard
130			Pin type face wrench	—
131		  	Adjustable pin type face wrench	—

2.3 Connecting Parts

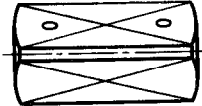
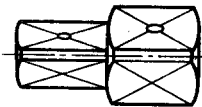
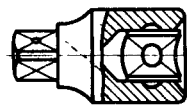
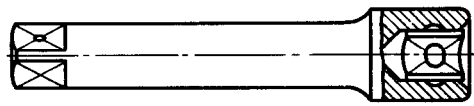
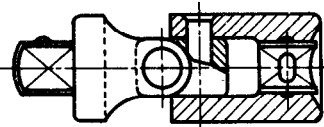
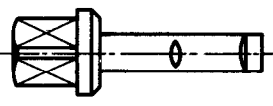
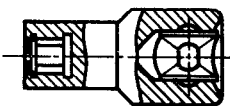

2.3.1 Nomenclature

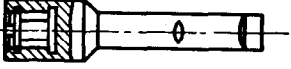



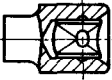
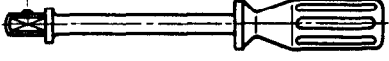
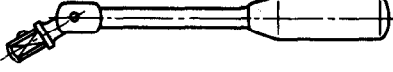
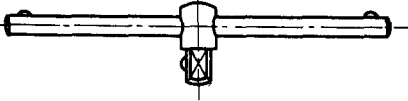
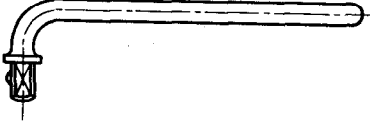

No.	Tool	Nomenclature	Indian Standard and ISO Standard
201		Square coupler	—
202		External square drive adapter	—
203		Adapter socket wrench	IS 7991 ISO 3316
204		Extension bar	IS 7991 ISO 3316
205		Universal joint, square drive	IS 7991 ISO 3316
206		Square drive bit for use with spiral ratchet drivers	IS 7991
207		Square drive socket for hexagon insert bits	—

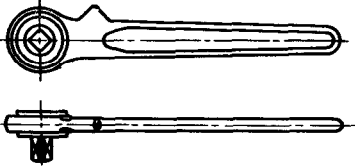
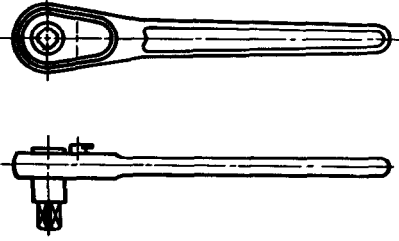
No.	Tool	Nomenclature	Indian Standard and ISO Standard
208		Adapter for hexagon insert bits for use with spiral ratchet driver	—

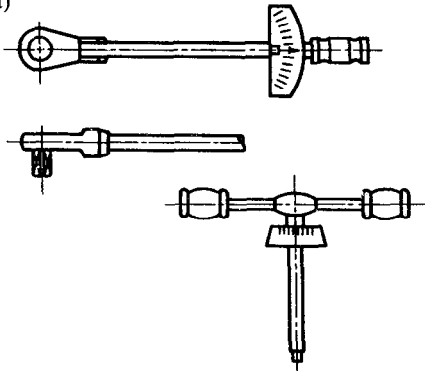
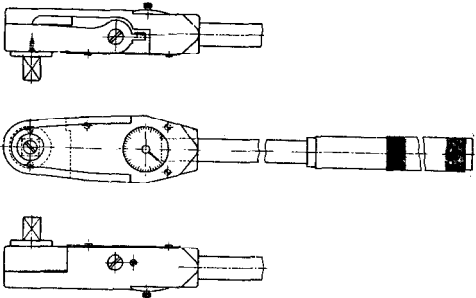
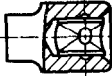
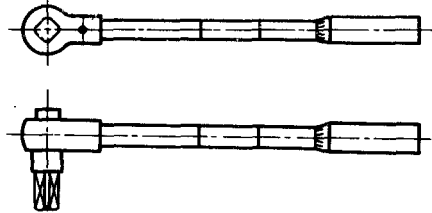
2.4 Driving Parts and Accessories

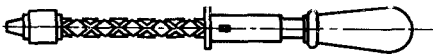
2.4.1 Nomenclature

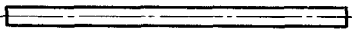







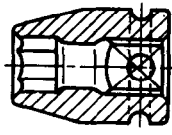
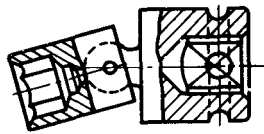
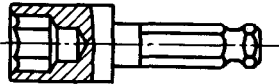
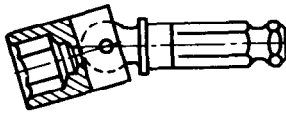

No.	Application	Tool	Nomenclature	Indian Standard and ISO Standard
251			Handle, spin type, male square	IS 7975 ISO 3315
252			Nut spinner, flex head	IS 7975 ISO 3315
253			Tee handle square drive	IS 7975 ISO 3315
254			Offset handle square drive	IS 7975 ISO 3315
255			Speed brace	IS 7975 ISO 3315
256			Ratchet handle	IS 7975 ISO 3315
257			Ratchet handle reversible	IS 7975

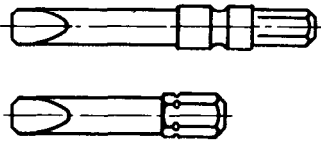
No.	Application	Tool	Nomenclature	Indian Standard and ISO Standard
258		<p>(a)</p> 	Torque wrench, deflecting beam type	—
		<p>(b)</p> 	Torque wrench rigid case with indicator dial type	—
259			<p>a) Torque; wrench, click type</p> <p>b) (Torque wrench, torque setting type)</p>	<p>IS 7268</p> <p>ISO 6789</p>
260			Screwdriver for hexagon insert bits	IS 8670
261			Spiral ratchet screwdriver	IS 12167
262			Hand impact screwdriver	—
263			<p>a) Tommy bar</p> <p>b) (Sliding tee bar)</p>	IS 6002
264			<p>a) Tommybar with reduced diameter</p> <p>b) (Sliding tee bar with reduced diameters)</p>	IS 6002

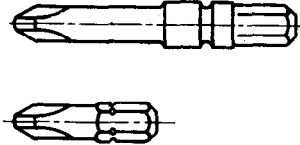
3 MACHINE OPERATED TOOLS FOR SCREWS AND NUTS

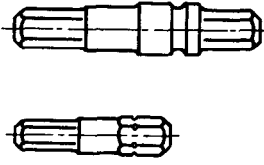
3.1 Socket Wrenches and Socket Drivers

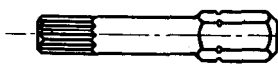
3.1.1 Nomenclature

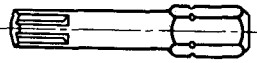
No.	Application	Tool	Nomenclature	Indian Standard and ISO Standard
301			Socket wrench, hexagon, Square drive	IS 7993 ISO 2725
302			Socket wrench, universal joint ball type, square drive	—
303			Socket wrench hexagon drive extension	IS 12476
304			Socket wrench, hexagon drive extension, universal joint ball type	—
305			Bit for slotted head screws, hexagon insert	—
306			Bit for recessed head screws, hexagon insert	—
307			Bit for hexagon socket screws, hexagon insert	IS 12481 ISO 3109
308			Bit for screws with internal serrations, hexagon insert	—
309			Hexagon insert bit for multispline screws	—

IS 6293 : 1996

3.2 Connecting Parts

3.2.1 Nomenclature

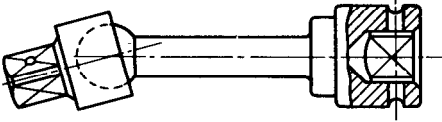
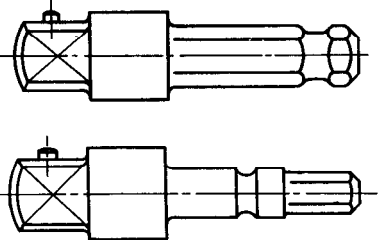
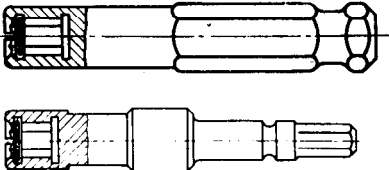
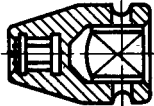
No.	Tool	Nomenclature	Indian Standard and ISO Standard
401		Square drive universal joint ball type extension	—
402		Square drive extension for hexagon insert	IS 12470 ISO 3317
403		Hexagon drive extension for hexagon insert bits	—
404		Square drive socket for hexagon insert bit	—

Bureau of Indian Standards

BIS is a statutory institution established under the *Bureau of Indian Standards Act, 1986* to promote harmonious development of the activities of standardization, marking and quality certification of goods and attending to connected matters in the country.

Copyright

BIS has the copyright of all its publications. No part of these publications may be reproduced in any form without the prior permission in writing of BIS. This does not preclude the free use, in the course of implementing the standard, of necessary details, such as symbols and sizes, type or grade designations. Enquiries relating to copyright be addressed to the Director (Publications), BIS.

Review of Indian Standards

Amendments are issued to standards as the need arises on the basis of comments. Standards are also reviewed periodically; a standard along with amendments is reaffirmed when such review indicates that no changes are needed; if the review indicates that changes are needed, it is taken up for revision. Users of Indian Standards should ascertain that they are in possession of the latest amendments or edition by referring to the latest issue of 'BIS Handbook' and 'Standards : Monthly Additions'.

This Indian Standard has been developed from Doc No. PE 05 (0105).

Amendments Issued Since Publication

Amend No.	Date of Issue	Text Affected

BUREAU OF INDIAN STANDARDS

Headquarters:

Manak Bhavan, 9 Bahadur Shah Zafar Marg, New Delhi 110002
Telephones : 323 01 31, 323 94 02, 323 83 75

Telegrams: Manaksanstha
(Common to
all offices)

Regional Offices:

Central : Manak Bhavan, 9 Bahadur Shah Zafar Marg
NEW DELHI 110002

Telephone

{ 323 76 17
323 38 41

Eastern : 1/14 C. I. T. Scheme VII M, V. I. P. Road, Maniktola
CALCUTTA 700054

{ 337 84 99, 337 85 61
337 86 26, 337 86 62

Northern : SCO 335-336, Sector 34-A, CHANDIGARH 160022

{ 60 38 43
60 20 25

Southern : C. I. T. Campus, IV Cross Road, MADRAS 600113

{ 235 02 16, 235 04 42
235 15 19, 235 23 15

Western : Manakalaya, E9 MIDC, Marol, Andheri (East)
MUMBAI 400093

{ 832 92 95, 832 78 58
832 78 91, 832 78 92

Branches : AHMADABAD. BANGALORE. BHOPAL. BHUBANESHWAR.
COIMBATORE. FARIDABAD. GHAZIABAD. GUWAHATI. HYDERABAD.
JAIPUR. KANPUR. LUCKNOW. PATNA. THIRUVANANTHAPURAM.