

The People's Republic of China

EDICT OF GOVERNMENT

In order to promote public education and public safety, equal justice for all, a better informed citizenry, the rule of law, world trade and world peace, this legal document is hereby made available on a noncommercial basis, as it is the right of all humans to know and speak the laws that govern them.

GB 18100-1 (2010) (English): Provisions for
the installation of lighting and
light-signalling devices for motorcycles,
Part 1: two-wheeled motorcycles



BLANK PAGE



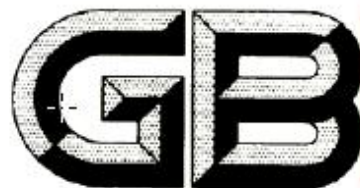

National Standard of the People's Republic of China

GB18100.1 - XXXX
Replaces GB 18100.2000 (motorcycle section)

Provisions for the installation of lighting and light-signalling devices for motorcycles

Part 1: two-wheeled motorcycles

(Draft for approval)

Issue Date: 20XX – XX – XX

Implementation Date: 200X – XX – XX

**Issued by the General Administration of Quality Supervision, Inspection and
Quarantine of the People's Republic of China and the Standardisation
Administration of the People's Republic of China**

Foreword

All of the technical contents set out in this Standard are mandatory.

GB18100, “Provisions for the installation of lighting and light-signalling devices for motorcycles” consists of three parts:

- Part 1: two-wheeled motorcycles;
- Part 2: two-wheeled mopeds;
- Part 3: three-wheeled motorcycles.

This is the first part of GB18100, which corresponds to Revision 1, Amendment 1, Amendment 2 and Amendment 3 of ECE R53 of the United Nations Economic Commission for Europe (UNECE), “Uniform provisions concerning the approval of category L3 vehicles with regard to the installation of lighting and light-signalling”, the conformance degree between this standard and the ECE R53 is non-equivalent, and the main technical differences are:

- terms and definitions have been deleted (refer to GB4785);
- there are circuit connection problems in the original standard, which in this Part have been modified as follows: front position lamp, rear position lamp and rear-registration plate lamp can only be switched on and off at the same time;
- with regard to non-uniformity description of the angle of the geometric visibility in the original standard, has in this Part been uniformed as follows: transverse angle β , and vertical angle α ;
- the installation quantities for driving beam headlamps and dipped beam headlamps are simplified to one or two lamps;
- considering the national conditions, the inclination requirements for dipped beams has been deleted;
- considering the national conditions, the content “when engine is running, the headlamp should come on automatically” within circuit connection has been deleted;
- only amber is used for the light colour of side retro-reflector devices;
- the light colour of the front fog light has been altered to white or amber, keeping conformity with motor vehicles.

Compared to the provisions for two-wheeled motorcycles specified in GB18100-2000, the main changes to this Part are as follows:

- according to the general provisions of Chapter 4 of GB/T1.1, adjustment to the contents structure has been made;
- directly used the terms set out in GB4785, repeated definitions have been avoided;
- the inclination requirements for dipped beams have been deleted, the relevant technical requirements and test methods are still in the process of research;
- a provision about two-wheeled motorcycles being able to use normal motor vehicle headlamps has been added, providing more choice for motorcycles;
- layout A (installing two lamps) on the installation quantity for direction indicators has been deleted;
- the installation quantities for rear position lamps, rear retro-reflector devices, front fog lamps and rear fog lamps have been altered from one to one or two, the corresponding contents have all been added or modified;
- the front position lamp has increased transverse requirements;
- the provisions for the flashing frequencies of the direction indicators are no longer to be detailed and split by DC and AC power supply and the flashing frequencies have been

- unified;
- requirements on transverse installation of driving beam headlamps and dipped beam headlamps have been added;
 - test methods have been deleted;
 - reference standards have been added, and within the general provisions the uniform provisions on requirements for photometric characteristics for each lamp have been specified.

Appendix A to this Part is a normative annex.

The implementation date of this Part is 1 January 2012.

This Part is proposed by China National Development and Reform Commission.

This Part is under the jurisdiction of the National Automobile Standardisation Technical Committee.

The organisations that participated in the drafting of this Part are:

China Automotive Technology & Research Centre;

Shanghai Automotive Lamps Research Institute;

Shanghai Motorcycle Research Institute;

The main drafters of this Part are: Xu Xiuxiang, Bu Weili, Jiang Yong.

This Part replaces the previously issued Standard: GB 18100-2000.

Provisions for the installation of lighting and light-signalling devices for motorcycles

Part 1: two-wheeled motorcycles

1 Scope

This Part specifies the general and specific provisions for the installation of lighting and light-signalling devices for category L3 two-wheeled motorcycles.

This Part applies to two-wheeled motorcycles (hereinafter referred to as the vehicles).

2 Normative References

The provisions of the following documents become provisions of this Part after being referenced. For dated reference documents, all later amendments (excluding corrigenda) and versions do not apply to this Part; however, the parties to the agreement are encouraged to study whether the latest versions of these documents are applicable. For undated reference documents, the latest versions apply to this Part.

GB 4599	Motor vehicle headlamps equipped with filament lamps
GB 4660	Motor vehicle front fog lamps equipped with filament lamps
GB 4785	Prescription for the installation of external lighting and light-signalling devices for motor vehicles and their trailers
GB 5948	Photometric characteristics of motorcycle headlamps equipped with filament light sources
GB 11554	Photometric characteristics of rear fog lamps for motor vehicles and their trailers
GB 11564	Retro-reflector device for motor vehicles
GB 17509	Photometric characteristics of direction indicators for motor vehicles and their trailers
GB 17510	Photometric characteristics of light-signalling devices for motorcycles

3 Terms and definitions

The terms and definitions set out in GB 4785 apply to this Part.

4 Requirements

4.1 General requirements

4.1.1 Lighting and light-signalling devices shall be installed so that under normal working conditions, despite the vibrations to which they may be subjected, they continue to function in accordance with the provisions set out in this Part; in particular, the start adjustment state must not be altered.

4.1.2 The installation of lighting devices should be appropriate for the correct adjustment of its direction.

4.1.3 When being installed, for all light-signalling devices – including those installed on the side of a vehicle – the reference axis of the light-signalling device should be parallel to the road stop plane of the vehicle. In addition, with regard to any side retro-reflector devices, the reference axis thereof must be perpendicular to the longitudinal plane of symmetry of the vehicle, the reference axes of all other light-signalling devices should be parallel to the longitudinal plane of symmetry of the vehicle; allowance in each direction should be $\pm 3^\circ$. If any special provisions

are specified by the manufacturer, then the installation should be conducted according to the manufacturer's instructions.

4.1.4 Unless otherwise specified, the reference centres of a single lamp or retro-reflector device should be located on the longitudinal plane of symmetry of the vehicle. Lamps installed in pairs should have the same functions, and should meet:

- a) relative to the longitudinal plane of symmetry of the vehicle, install symmetrically;
- b) relative to the longitudinal plane of symmetry of the vehicle, reciprocally symmetry with geometric shape;
- c) meet the same chromaticity requirement;
- d) meet the same photometric characteristics;
- f) switched on/off at a same time.

4.1.5 Unless otherwise specified, lamps with different functions and also meet their own requirements can be grouped, combined or reciprocally incorporated with one another.

4.1.6 Unless otherwise specified, only direction indicators and hazard warning signalling lamps can flash.

4.1.7 After a registration plate is installed, the geometry visibility of each lamp should still meet the requirements.

4.2 Circuit connection

4.2.1 The front position lamp, rear position lamp and rear-registration plate lamp can only be switched on or off at the same time.

4.2.2 Unless otherwise specified, only when the abovementioned lamps are switched on can the driving beam headlamp, dipped beam headlamp and fog lamp be switched on. When the driving beam headlamp and dipped beam headlamp give warning signals (means when they switch intermittently between driving beam headlamp and dipped beam headlamp, or switch intermittently alternating between driving beam headlamp and dipped beam headlamp), these requirements are not applicable.

4.3 Indicator

4.3.1 Each type of indicator should be positioned such that it is easy for the driver to see.

4.3.2 The "closed-circuit" indicator can be replaced by an "operating" indicator.

4.4 Light colour and chromaticity characteristics

See Table 1 for the requirements for light colour emitted by the lamps. Chromaticity characteristics should conform to the provisions set out in GB 4785.

4.5 General requirements on the installation of lamps

Vehicles should be equipped with the lighting and signalling devices specified in Table 1. Any other lighting and signalling devices not mentioned in Table 1 must not be used. Headlamps (driving beam headlamps and dipped beam headlamps) should conform to the provisions set out in GB 5948 or GB 4599 (excluding sealed-beam lamps); front position lamps, rear position lamps, stop lamps and rear-registration plate lamps should conform to the provisions set out in GB 17510; direction indicators should conform to the relevant provisions set out in GB 17509 or GB 17510; non-triangular rear retro-reflector devices and non-triangular side retro-reflector devices should conform to the provisions set out in GB11564; front fog lamps should conform to the provisions set out in GB 4660 and rear fog lamps should conform to the provisions set out

in GB 11554.

Table 1 Light colour of the lamps and their installation requirements

Lamp type	Light colour	Installation requirement
Headlamps (driving beam headlamp and dipped beam headlamp)	White	Mandatory installation
Front position lamp	White	Mandatory installation
Rear position lamp	Red	Mandatory installation
Direction indicator	Amber	Mandatory installation
Stop lamp	Red	Mandatory installation
Rear-registration plate lamp	White	Mandatory installation
Non-triangular rear retro-reflector device	Red	Mandatory installation
Non-triangular side retro-reflector device	Amber	Mandatory installation
Vehicle hazard warning signalling lamp	Amber	Optional installation
Front fog lamp	White or amber	Optional installation
Rear fog lamp	Red	Optional installation

4.6 Non-visibility of front-view red light and rear-view white light

Red light should not be visible from the front of a vehicle and white light should not be visible from the rear of a vehicle. These can be inspected using the following method (see Appendix A):

- a) the non-visibility of front-view red light: the viewer should not be able to directly see the red light by moving observation from Zone I of the transverse plane, which is a distance of 25 m from the front of the vehicle.
- b) the non-visibility of rear-view white light: the viewer should not be able to directly see the white light by moving observation from Zone II of the transverse plane which is a distance of 25 m from the rear of the vehicle.

Within the abovementioned transverse planes, the range of Zone I and Zone II for visual inspection of the observer are as follows:

- a) at height direction: limited by two horizontal plane with height from the ground of 1 m and 2.2 m;
- b) at transverse direction: at the front of the vehicle and the rear of the vehicle, limited by two vertical planes which form outward 15° angles with the longitudinal plane of symmetry of the vehicle respectively. These planes should pass the relevant intersection line (which means the intersection line between the parallel longitudinal planes of symmetry of the vehicle which is used to limit the vehicle's overall width and the perpendicular longitudinal planes of symmetry of the vehicle which is used to limit the vehicle's overall length).

4.7 General requirements for the measurement of lamp positions

4.7.1 The measurements of maximum and minimum height above ground should start from the highest point and lowest point of the apparent surface on the reference axis direction. With regard to dipped beam headlamps, the minimum height above the ground thereof should be measured from the lowest point of the effective aperture of optical system (reflector, lens, projection lens); if the height (maximum and minimum) above the ground clearly meet the requirements, then the precise edge of any surface is not required to be determined.

The distance between two lamps in the transverse direction should be determined from the inner edge of the apparent surface in the reference axis direction. If the installation locations on the transverse direction clearly meet the requirements, then the precise edge of any surface is not required to be determined.

4.7.2 Unless otherwise specified, when inspecting the installation height and directions of the lamps, the test vehicle should be unladen and placed on level ground, its longitudinal plane of symmetry should be vertical, and the direction changing handle should be at a forward straight ahead position, with the tyre pressure conforming to the specifications of the manufacturer.

Note: unladen vehicle means no driver, no passenger and no load, but equipped with sufficient fuel and vehicle accessory tools.

5 Special provisions

5.1 Driving beam headlamp

5.1.1 Quantity: one or two

5.1.2 Arrangement: no special requirement

5.1.3 Position

5.1.3.1 Transverse direction

5.1.3.1.1 Single driving beam headlamps can be positioned above, below or to the side of other front lamps of the vehicle. If these lamps are arranged in order of up and down, then the reference centre of the driving beam headlamp should be located on the longitudinal plane of symmetry of the vehicle; if these lamps are arranged in transverse order, then the reference centres of these lamps should be symmetrical to the longitudinal plane of symmetry of the vehicle.

5.1.3.1.2 The reference centre of driving beam headlamps which are reciprocally incorporated with other front lamps of the vehicle should be located on the longitudinal plane of symmetry of the vehicle. If a vehicle only has a single individual dipped beam headlamp installed, or a dipped beam headlamp and a front position lamp are reciprocally incorporated and positioned near to the driving beam headlamp, then the reference centres of these lamps should be symmetrical to the longitudinal plane of symmetry of the vehicle.

5.1.3.1.3 If two driving beam headlamps are installed, and one or both of the headlamps are reciprocally incorporated with other front lamps of the vehicle, then the reference centres of these lamps should be symmetrical to the longitudinal plane of symmetry of the vehicle.

5.1.3.1.4 Under all circumstances, the distance between the edge of the illuminating surface of a single driving beam headlamp and the edge of the illuminating surface of a single dipped beam headlamp should not exceed 200 mm. The distance between the illuminating surfaces of two driving beam headlamps must not exceed 200 mm.

5.1.3.2 At height direction: the height above the ground should be 500 mm ~ 1 300 mm.

5.1.3.3 At longitudinal direction: positioned in the front of the vehicle. The light emitted should neither directly nor indirectly cause any discomfort to the driver in its reflection in the rear-view

mirror or other reflective surfaces of the vehicle.

5.1.4 Geometric visibility

Angles α at vertical directions: upward and downward 5° ;

Angles β at transverse directions: left and right 5° .

5.1.5 Direction: forward. The lamp should be able to turn along with the direction changing handle.

5.1.6 The driving beam headlamp must not combine with any other lamps.

5.1.7 Circuit connection: when the driving beam headlamp is switched on, the dipped beam headlamp is also permitted to be on.

5.1.8 "Closed-circuit" indicator: must be equipped with a non-flashing blue signalling lamp.

5.1.9 Other requirements: when the driving beam headlamps are simultaneously connected, the maximum luminous intensity should not exceed 225 000cd.

5.2 Dipped beam headlamps

5.2.1 Quantity: one or two

5.2.2 Arrangement: no special requirement

5.2.3 Position

5.2.3.1 Transverse direction

5.2.3.1.1 Single dipped beam headlamps can be positioned above, below or to the side of other front lamps of the vehicle. If these lamps are arranged in order of up and down, then the reference centre of the dipped beam headlamp should be located on the longitudinal plane of symmetry of the vehicle; if these lamps are arranged in order of transverse, then the reference centres of these lamps should be symmetrical to the longitudinal plane of symmetry of the vehicle.

5.2.3.1.2 The reference centre of dipped beam headlamps which are reciprocally incorporated with the other front lamps of the vehicle should be positioned on the longitudinal plane of symmetry of the vehicle. If a vehicle only has a single individual driving beam headlamp installed, or a driving beam headlamp and a front position lamp are reciprocally incorporated and positioned near the dipped beam headlamp, then the reference centres of these lamps should be symmetrical to the longitudinal plane of symmetry of the vehicle.

5.2.3.1.3 If two dipped beam headlamps are installed, and one or both of the headlamps are reciprocally incorporated with other lamps of the vehicle, then the reference centres of these lamps should be symmetrical to the longitudinal plane of symmetry of the vehicle.

5.2.3.1.4 The distance between the illuminating surfaces of two dipped beam headlamps must not exceed 200 mm.

5.2.3.2 At height direction: the height above the ground should not be lower than 500 mm and not higher than 1200 mm.

5.2.3.3 At longitudinal direction: positioned in the front of the vehicle. The light emitted should not directly or indirectly cause any discomfort to the driver in its reflection in the rear-view mirror or other reflective surfaces of the vehicle.

5.2.4 Geometric visibility

Angles α at vertical directions: upward 15° and downward 10° ;

Angles β at transverse directions: for single lamps, left and right 45° . For lamps installed in pairs – outward 45° and inward 10° .

The existence of other components which are positioned near the headlamps should not cause any discomfort to other road users.

5.2.5 Direction: forward. The lamp can be turned along with the direction-changing handle.

5.2.6 Circuit connection: when changing the dipped beam, all of the driving beam headlamps should be switched off at the same time.

5.2.7 Indicator: optional installation. If it is installed, it should be a non-flashing green signalling lamp.

5.2.8 Dipped beam headlamps must not be combined with any other lamps.

5.2.9 Other requirements: none.

5.3 Direction indicators

5.3.1 Quantity: two on each side.

5.3.2 Arrangement: two front-direction indicators and two rear-direction indicators.

5.3.3 Position

5.3.3.1 Transverse direction

Front-direction indicators should meet the following requirements:

a) The minimum distance between the illuminating surfaces of both direction indicators should be 240 mm.

b) The direction indicators should be positioned on the extreme outer edge of the vertical plane which is tangent to the outer edge of the illuminating surface of the headlamps.

c) The distance between the direction indicators to the illuminating surface of the nearest dipped beam headlamp should meet the specifications set out in Table 2:

Table 2: The minimum distance between a direction indicator and a dipped beam headlamp

Minimum luminous intensity of a direction indicator (cd)	Minimum distance (mm)
90	75
175	40
250	20
400	≤ 20

The distance between the inner edges of the illuminating surfaces of two rear-direction indicators should be at least 180mm.

5.3.3.2 At height direction: the height above the ground should not be lower than 350 mm and not higher than 1 200 mm.

5.3.3.3 At longitudinal direction: the distance between the reference centre of the rear-direction indicator and the transverse plane of the rear longitudinal plane of the vehicle should not exceed 300 mm.

5.3.4 Geometric visibility

Angles β at transverse directions: outward 80° and inward 20° .

Angles α at vertical directions: from transverse plane upward 15° and downward 15° . If the lamp height is lower than 750 mm, then the elevating angle below the transverse plane can be reduced to 5° .

5.3.5 Direction: the front direction indicator can be rotated along with the direction changing handle.

5.3.6 The direction indicators must not be combined with any other lamps.

5.3.7 The direction indicators must not be reciprocally incorporated with any other lamps.

5.3.8 Circuit connection: direction indicators should be switched on individually; the on and off functions of all direction indicators which are positioned on the same side of a vehicle should be controlled by the same device.

5.3.9 Operating indicator: mandatory installation. It can be optical, acoustical or both. If optical, it must be a flashing green signalling lamp; under normal driving conditions it should be visible. If any direction indicator happens not to be working properly, then the operating indicator shall be extinguished or no longer flashing or flashing with a noticeable different frequency.

5.3.10 Other requirements: apart from any necessary load required for the normal operation of the engine and lamp equipment, when conducting the following measurements, the electric system must not hold any other load.

5.3.10.1 The flashing frequency should be (90 ± 30) times/min.

5.3.10.2 The direction indicators on the same side of the vehicle can flash at the same time or alternately.

5.3.10.3 The light-signalling device should be lit within one second of the control device being switched on, and should be extinguished within 1.5 seconds of the control device being switched off.

5.3.10.4 If any one direction indicator loses efficacy but this is not caused by a short circuit, then the other direction indicators in the same direction should carry on working. The flashing frequency can be different from the abovementioned provisions.

5.4 Stop lamp

5.4.1 Quantity: one or two

5.4.2 Arrangement: no special requirement

5.4.3 Position

5.4.3.1 At height direction: the height above the ground should not be lower than 250 mm and not higher than 1 500 mm.

5.4.3.3 At longitudinal direction: positioned at the rear of the vehicle.

5.4.4 Geometric visibility

Angles β at transverse directions: for single lamps, left and right 45° . For lamps installed in pairs: outward 45° and inward 10° .

Angles α at vertical directions: from transverse plane upward 15° and downward 15° . If the lamp height is lower than 750 mm, then the elevating angle below the transverse plane can be reduced to 5° .

5.4.5 Direction: backward.

5.4.6 The stop lamp must not be combined with any other lamps.

5.4.7 Circuit connection: under a stop condition of any vehicle, the stop lamp must be lit.

5.4.8 “Closed-circuit” indicator: forbidden to use.

5.4.9 Other requirements: none.

5.5 Rear-registration plate lamp

5.5.1 Quantity: one. Can be formed by several optical elements used to light the space left for the registration plate.

5.5.2 Arrangement: ensured to be able to light the space left for the registration plate.

5.5.3 Position

5.5.3.1 At transverse direction: be able to light the space left for the registration plate.

5.5.3.2 At height direction: be able to light the space is left for the registration plate.

5.5.3.3 At longitudinal direction: be able to light the space left for the registration plate.

5.5.4 Geometric visibility: be able to light the space left for the registration plate.

5.5.5 Direction: be able to light the space left for the registration plate.

5.5.6 Indicator: optional installation. Its function should be completed by the indicator of the position lamp.

5.5.7 Other requirements: when the rear-registration plate lamp is combined with the rear position lamp, and the rear position lamp is reciprocally incorporated with the stop lamp or rear fog lamp, then the photometric characteristics of the rear-registration plate lamp can change when the stop lamp or rear fog lamp is switched on.

5.6 Front position lamp

5.6.1 Quantity: one or two

5.6.2 Arrangement: no special requirement

5.6.3 Position

5.6.3.1 At transverse direction

Single front position lamps can be positioned above, below or to the side of other front lamps of a vehicle. If these lamps are arranged in order of up and down, then the reference centre of the front position lamp should be positioned on the longitudinal plane of symmetry of the vehicle; if these lamps are arranged in order of transverse, then the reference centres of these lamps should be symmetrical to the longitudinal plane of symmetry of the vehicle.

The reference centre of front position lamps which are reciprocally incorporated with other front lamps of a vehicle should be positioned on the longitudinal plane of symmetry of the vehicle. If other lamps are installed near to the front position lamp, then the reference centres of these lamps should be symmetrical to the longitudinal plane of symmetry of the vehicle.

When two front position lamps are installed, and one or both lamps are reciprocally incorporated with other front lamps of the vehicle, then the reference centres of these lamps should be symmetrical to the longitudinal plane of symmetry of the vehicle.

5.6.3.2 At height direction: the height above the ground should not be lower than 350 mm and not higher than 1 200 mm.

5.6.3.3 At longitudinal direction: positioned at the front of the vehicle.

5.6.4 Geometric visibility

Angles β at transverse directions: for single lamps, left and right 80° respectively. For lamps installed in pairs, outward 80° and inward 45° .

Angles α at vertical directions: from transverse plane upward 15° and downward 15° . If the lamp height is lower than 750mm, then the elevating angle below the transverse plane can be reduced to 5° .

5.6.5 Direction: forward. The lamps can be turned along with the direction changing handle.

5.6.6 "Closed-circuit" indicator: a non-flashing green signal lamp must be installed. If the dashboard lamp can be switched on and off at the same time as the position lamp, then the installation of the indicator is not required.

5.6.7 Other requirements: none.

5.7 Rear position lamp

5.7.1 Quantity: one or two

5.7.2 Arrangement: no special requirement

5.7.3 Position

5.7.3.1 At height direction: the height above the ground should not be lower than 250 mm and not higher than 1 500 mm.

5.7.3.2 At longitudinal direction: positioned at the rear of the vehicle.

5.7.4 Geometric visibility

Angles β at transverse directions: for single lamps, left and right 80° respectively. For lamps installed in pairs, outward 80° and inward 45° .

Angles α at vertical directions: from transverse plane upward 15° and downward 15° . If the lamp height is lower than 750 mm, then the elevating angle below the transverse plane can be reduced to 5° .

5.7.5 Direction: backward.

5.7.6 "Closed-circuit" indicator: optional installation. If it is installed, its function should be completed by the indicator of the position lamp.

5.7.7 Other requirements: none.

5.8 Non-triangular rear retro-reflector device

5.8.1 Quantity: one or two

5.8.2 Arrangement: no special requirement

5.8.3 Position

5.8.3.1 At height direction: the height above the ground should not be lower than 250mm and not higher than 900 mm.

5.8.3.2 At longitudinal direction: positioned at the rear of the vehicle.

5.8.4 Geometric visibility

Angles β at transverse directions: for single retro-reflector devices, left and right 30° respectively. For retro-reflectors installed in pairs, outward 30° and inward 10° .

Angles α at vertical directions: from transverse plane upward 15° and downward 15° . If the

lamp height is lower than 750mm, then the elevating angle below the transverse plane can be reduced to 5°.

5.8.5 Direction: backward.

5.9 Hazard warning signalling lamp

5.9.1 Hazard warning signal of a vehicle is generated by all of the direction indicators which meet to the provisions set out in 5.3 and are working at a same time.

5.9.2 Circuit connection: an individual control device is used to ensure all direction indicators to work at a same time.

5.9.3 “Closed-circuit” indicator: a red flashing signalling lamp must be installed, or under the circumstance of the indicators are separated, enable the indicators which conform to the provisions set out in 5.3.10 to work at a same time.

5.9.4 Other requirements: flashing frequency should be (90 ± 30) times per minute.

Within one second of the light-signalling control device is switched on, all of the direction signal lamps should be lit, within one and a half second of the light-signalling control device is switched off, all of the direction signalling lamps should be extinguished.

When the ignition control device is enabling the engine in an off state, the hazard warning signal device should be ensured to be able to be switched on.

5.10 Front fog lamp

5.10.1 Quantity: one or two

5.10.2 Arrangement: no special requirement

5.10.3 Position

5.10.3.1 At transverse direction: The reference centre of a single lamp should be positioned on the longitudinal plane of symmetry of the vehicle. The distance between the illuminating surface edge that is nearest to the longitudinal plane of symmetry of the vehicle to the longitudinal plane of symmetry does not exceed 250 mm.

5.10.3.2 At height direction: the height above ground should not be lower than 250 mm; the entire illuminating surface must be below the highest point of the illuminating surface of the dipped beam headlamp.

5.10.3.3 At longitudinal direction: positioned at the front of the vehicle. The light emitted should not directly or indirectly cause any discomfort reflection to the driver by the rear-view mirror or other reflective surfaces of the vehicle.

5.10.4 Geometric visibility

Angles β at transverse directions: for single lamps, left and right 45° respectively, when deviate from the longitudinal plane of symmetry should be inwards 10°. For lamps installed in pairs, should be outward 40° and inward 10°.

Angles α at vertical directions: upward 15° and downward 5° respectively;

5.10.5 Direction: forward. The lamps can be turned along with the direction changing handle.

5.10.6 The front fog lamp must not be combined with any other lamps.

5.10.7 Circuit connection: the switch on/off function of the front fog lamp should be independent from the on/off of the driving beam headlamp and the dipped beam headlamp.

5.10.8 “Closed-circuit” indicator: optional installation. If it is installed, it should be a non-

flashing green signal lamp.

5.10.9 Other requirements: none.

5.11 Rear fog lamp

5.11.1 Quantity: one or two

5.11.2 Arrangement: no special requirement

5.11.3 Position

5.11.3.1 At height direction: the height above the ground should not be lower than 250 mm and not higher than 900 mm.

5.11.3.2 At longitudinal direction: positioned at the rear of the vehicle.

5.11.3.3 The distance between the illuminating surface of the rear fog lamp and the illuminating surface of the stop lamp should not be less than 100 mm.

5.11.4 Geometric visibility

Angles β at transverse directions: for single rear fog lamp, left and right 25° respectively. For lamps installed in pairs, outward 30° and inward 10° .

Angles α at vertical directions: upward 15° and downward 15° .

5.11.5 Direction: backward.

5.11.6 Circuit connection: the rear fog lamp can only be lit when one or several of the driving beam headlamps, dipped beam headlamps or front fog lamps is/are switched on. If a front fog lamp is installed, the rear fog lamp should be able to be switched off independently from the front fog lamp. The rear fog lamp can continue to work, but must be off when the position lamp is switched off, and until it is switched on again.

5.11.7 "Closed-circuit" indicator: must be installed. The indicator should be a non-flashing amber signal lamp.

5.11.8 Other requirements: none.

5.12 Non-triangular side retro-reflector device

5.12.1 Quantity at each side: one or two

5.12.2 Arrangement: no special requirement

5.12.3 Position

5.12.3.1 At height direction: the height above the ground should not be lower than 300 mm and not higher than 900 mm.

5.12.3.2 At longitudinal direction: under normal conditions, the installation location should be ensured not to be blocked by the clothing of the driver or passenger.

5.12.4 Geometric visibility

Angles β at transverse directions: forward and backward 30° respectively. If the height of the retro-reflector device is lower than 750 mm, then the elevating angle below the transverse plane can be reduced to 5° .

5.12.5 Direction: the reference axis of the retro-reflector device must be perpendicular to the longitudinal plane of symmetry of the vehicle and face outward. The front side retro-reflector device should be able to turn along with the turning handle.

6 Inspection rules

6.1 Type inspection

Manufacturers who have applied for a type inspection of the installation of lighting and light-signalling devices should submit one unladen vehicle, which should be equipped with a whole set of lighting and light-signalling devices. The following documents should also be submitted:

- a) an outline drawing presenting the overall dimensions of the vehicle, and a manual identifying the vehicle models;
- b) a complete installation diagram of the lighting and light-signalling device. The installation location of each device on the vehicle should be clearly marked;
- c) an outline drawing presenting the illuminating surface, the light emitting surface, the reference axis and the reference centre of each type lamp, and a manual about the determination method of the apparent surface. The registration plate illuminating device is not included.

The type of the vehicle submitted for the type test should meet the provisions set out in Chapters 4 and 5.

6.2 Production conformity inspection

A random sample inspection should be conducted on vehicles which have qualified from the type test and have been in continuous production. The installation of lighting and light-signalling devices on each vehicle should conform to the vehicle type of the type test.

Appendix A

(Normative Annex)

Non-visibility of front-view red light and rear-view white light

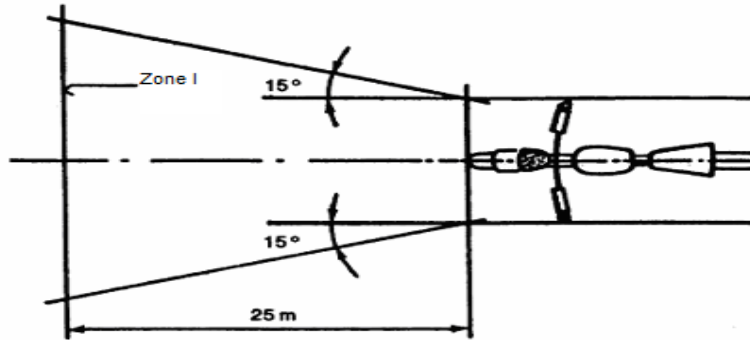

Diagram A.1 Non-visibility of front-view red light

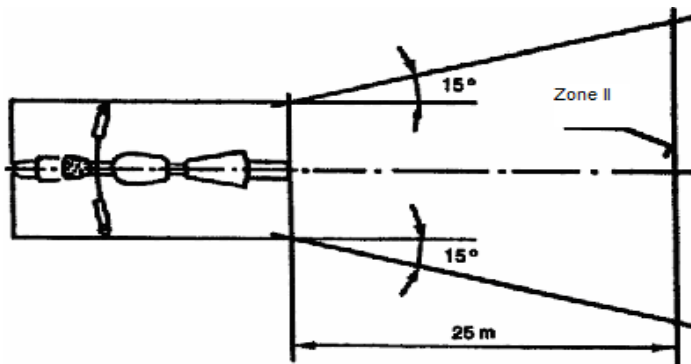

Diagram A.2 Non-visibility of rear-view white light